





# Instruction Manual

## Ionizer Blow Type [DTY-ELK01F]

Thank you very much for your purchase of the DTY-ELK01F. Although this product is not classified as a high-voltage device under any electrical equipment standards, it uses a 2000VAC high voltage. Please read this manual diligently in order to handle this unit carefully and correctly. Keep this manual in a safe place.

### 1. Safety Precautions

Because a high voltage is used in this product, improper use of the unit may cause an accident resulting in injury or death, or may lead to a malfunction of the product. Koganei will not be held liable for any usage outside the Product Specifications or for any accident caused by noncompliance with the Safety Precautions.

 <b>DANGER</b>	Expresses situations that can be clearly predicted as dangerous. If the noted danger is not avoided, it could result in death or serious injury. It could also result in damage or destruction of assets.
 <b>WARNING</b>	Expresses situations that, while not immediately dangerous, could become dangerous. If the noted danger is not avoided, it could result in death or serious injury. It could also result in damage or destruction of assets.
 <b>CAUTION</b>	Expresses situations that, while not immediately dangerous, could become dangerous. If the noted danger is not avoided, it could result in light or semi-serious injury. It could also result in damage or destruction of assets.
 <b>ATTENTION</b>	While there is little chance of injury, this content refers to points that should be observed for appropriate use of the product.

#### 1.1 DANGER

Do not use in locations where explosives, flammables, or other dangerous substances are present. This product is not an explosion-proof type unit. Explosion or ignition may occur.
When any wiring, installation, or inspection work is to be carried out, make sure that the unit is disconnected from the power supply, otherwise, an accident, an electrical shock or a malfunction may be caused.
Never attempt to remodel the product. It could result in abnormal operation leading to injury, electric shock, fire, etc.
Do not splash water on the product. Spraying it with water, washing it, or using it underwater could result in malfunction of the product leading to injury, electric shock, fire, etc.
A high voltage is applied to the discharge needle. Do not allow any conductive material, including fingers, any part of the body, wires or tools to come close to the needle. Otherwise, an electric shock or a malfunction of the unit may occur.

#### 1.2 WARNING

Do not use the product in excess of its specification range. Such use could result in product breakdowns, function stop, damage or drastic reduction in the operating life.
The discharge needle has a sharp edge. Pay special attention to handling of the needle, or you may injure yourself.
Always make sure that the air supply is active before turning ON the unit. If the air supply is not active when the power supply is applied there may be a build-up of ozone inside the unit due to electrical discharge that could have an adverse effect on the equipment and the environment.
When using the nozzle, do not point it toward a person's body, and particularly not toward the face and eyes. You may injure yourself or other persons.

#### 1.3 CAUTION

Ionizers generate trace amounts of ozone and NOx in the atmosphere. Do not use them in a sealed space. Using multiple units simultaneously in a confined area may increase the ozone concentration. If you detect the smell of ozone, please ventilate the area. Furthermore, do not bring your face directly close to the ion air outlet to check for ozone odor, as this may damage your nose, throat, or other areas.
Please design surrounding facilities and equipment with safety in mind, considering factors such as ozone degradation of peripheral devices and ozone exposure to workers.
The air source supplied to the product must be clean and free from contaminants such as degraded compressor oil. Failure to do so can significantly reduce the product's performance and potentially cause function failure.

#### 1.4 ATTENTION

When the product can no longer be used or is no longer needed, dispose of it appropriately as industrial waste.
---

\* For any other items of danger, warning, or caution, please refer to the "Safety Precautions" in the Catalog for the "Static Electricity Removing Unit: Ionizer" (Catalog No. R0010). (Be sure to refer to the latest version of the Catalog.)

### 2. Product Overview

This product is a blow type ionizer (a device for eliminating static electricity). This product is helpful in quickly resolving problems with static electricity. Ionized air quickly and efficiently neutralizes the static electricity on charged objects, and removes dust attracted by the static electricity. This effectively controls static electricity problems and dust contamination problems. You can also select a low-dust type that suppresses dust generation, depending on uses and needs.

### 3. Contents of the Package

On receipt of the product, please check the package for any missing parts or for any abnormality or damage that may have occurred during delivery before using the unit. In case any damage should be found or any abnormal operation should be observed, please contact the outlet (the agency) at which you purchased the product, or the nearest Koganei service station.

#### 3.1 Content of Package

- Main unit : 1
- Discharge needle unit\*1 : 1
- Standard nozzle (DTY-NZKF-01S) \*1: 1
- Power and signal cable (2 m): 1
- Homepage information : 1

\* 1. Attached to main unit at time of shipping.

### 4. Specifications

#### 4.1 List of Specifications

Type	DTY-ELK01F (Standard)	DTY-ELK01F-L (Low-dust)
Input power source	24VDC ± 5%	
Current consumption	50 mA	
Output voltage	Approx. 2 kV <sub>p-p</sub> (High frequency type)	
Displays	PWR LED (Green)	When the power is ON
	H.V LED (Blue)	When discharge is in operation
	CHK LED (Yellow)	When abnormal discharge occurs (H.V LED goes OFF)
	ALM LED (Red)	When abnormal function occurs (H.V LED goes OFF)
Output	Contact point output when CHK LED and ALM LED are ON (24V 50 mA MAX Open Drain)	
Ionizer ON/OFF control input	At 0V, discharge stops with short-circuited (No-voltage input, internal drop voltage 0.5V or less)	
Ion balance*1	±10V or less (at a distance of 50 mm and air pressure of 0.3 MPa)	
Static elimination time*1,2,2	0.5 sec or less	0.5 sec or less
Generated ozone volume	0.03 ppm or less (at a distance of 300 mm and air pressure of 0.015 MPa)	
Dust volume	-	50 particles or less*1,3
Air tube connection diameter	φ4 quick fitting	Rc1/8
Range of air pressure used	0.01 MPa to 0.3 MPa	
Air supply flow volume*4 (ANR)	50 l/min or less	
Media	Air (Clean air devoid of moisture and oil)	
Operating environment	Temperature	0 to 40°C (indoor)
	Humidity	15% to 65% RH (with no condensation)
	Mass	50 g*5
		55 g*5

\*1. Measured under the measuring conditions specified by Koganei.

2. Measurement distance 50 mm, air supply pressure 0.3 MPa, standard nozzle in use
3. 0.3 μm or more, 1 cf/min
4. Air supply pressure of 0.3 MPa
5. When the standard nozzle attached.

## 5. Appearance

### DTY-ELK01F (Standard type)

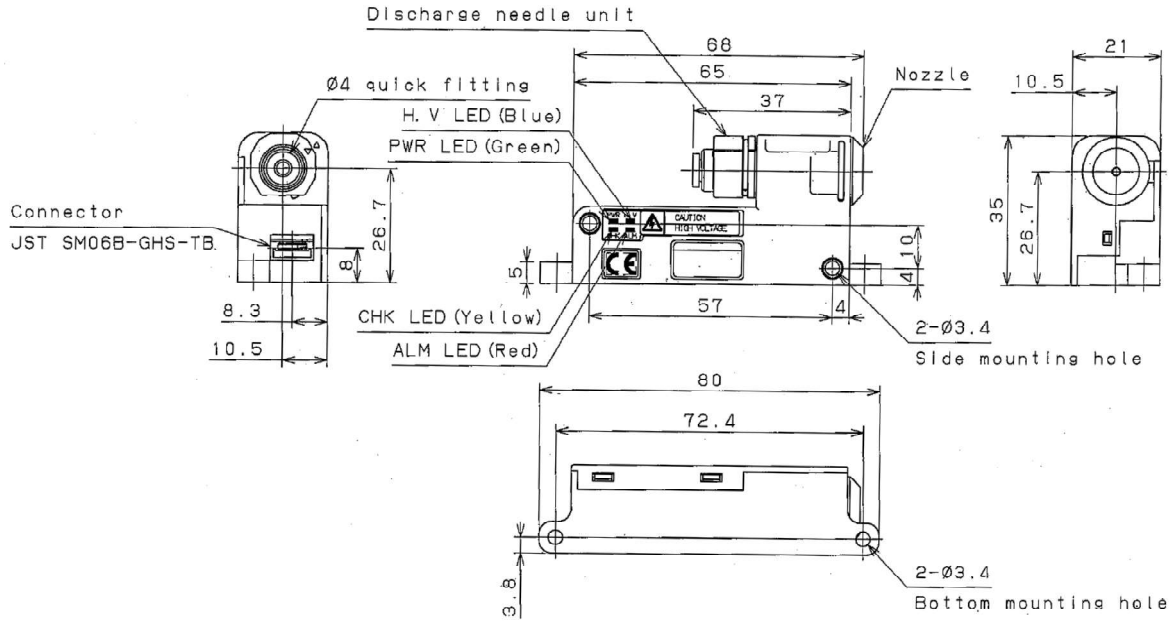

### DTY-ELK01F-L (Low dust type)

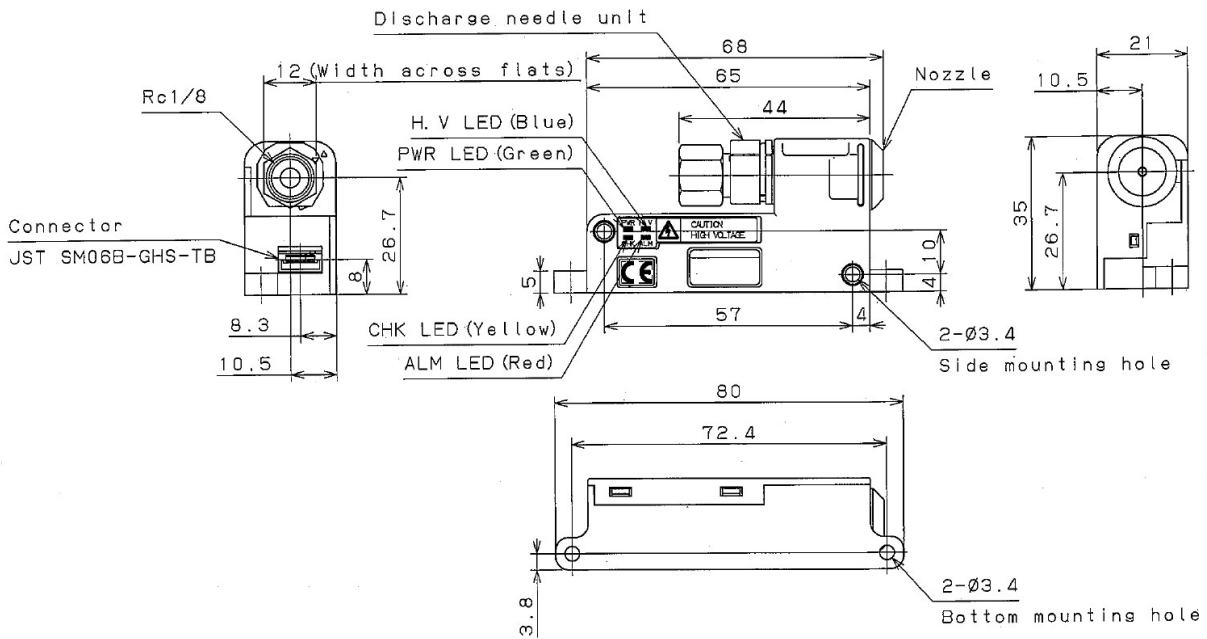

### Power and signal cable DTY-ZKFDSC (Accessories)

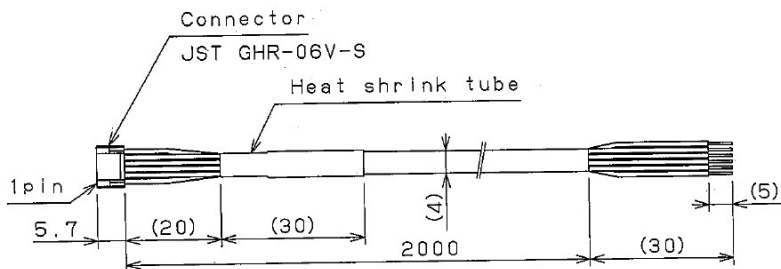

## 6. Installation, Wiring and Tubing

### 6.1 Installation

#### ⚠ CAUTION

DTY-ELK01F-L (low-dust type) uses clean room packaging. Always open the packaging in a clean room environment.

Nozzles are made specifically for each type. Always use the right nozzle for each type.

- 1) Secure the product using the mounting holes on the side of the main unit (φ3.4, 2 locations) or the mounting holes on the bottom (φ3.4\$, 2 locations).

\* Please prepare the mounting screws separately.

#### ⚠ CAUTION

The tightening torque when mounting the main unit should be 0.3 N · m or less.

- 2) If you purchase an optional nozzle, remove the standard nozzle after pulling out the pin when replacing the nozzle. Attach the replacement nozzle to the main unit, and secure it to the main unit with the pin included with the nozzle.

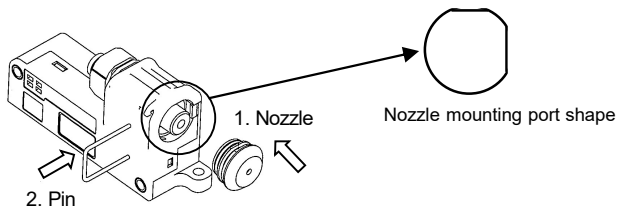

#### ⚠ WARNING

Check that the nozzle is securely inserted and securely held in place by the pin. If not perfectly set, the nozzle could come loose during use, damaging the product and equipment.

#### ⚠ CAUTION

The nozzle insertion part is made in a D-shaped cut to prevent rotation. When attaching, align the main unit nozzle insertion port with the nozzle insertion part.

As piezoelectric ceramic is built into the main unit, do not apply shocks due to dropping or vibration, etc. Such action could result in product malfunction.

Do not use nozzles not specifically designed for the unit. Also, do not make modifications to the nozzle. Such action could be the cause of product malfunctions, function shutdown, or damage.

Do not install in locations prone to condensation, or subject to large humidity and temperature swings. The product could be subjected to damage.

### 6.2 Wiring

- 1) Use the power signal cable provided, and connect as shown in the figure below.

If taking power from input 100VAC, use the AC adaptor (DTY-ZKFPS), sold separately.

#### ⚠ CAUTION

Securely connect the ground wire (with a grounding resistance of 100Ω or less). Otherwise, ionizer performance may not be adequate.

Securely insert the connector.

Contact capacity for each output is 24V 50 mA MAX. Check the capacity of the connected equipment before use.

Please be aware of the inrush current when powering on. Depending on the connected load, there is an increased risk of product malfunction or failure.

0VDC, F.G, nozzle and mounting bracket are connected to the internal circuit.

Use a mechanical switch, photo coupler, or relay for external input. If the grounding potential of the external device is to be used and the grounding potential of this product are different, the external device should have an insulated on/off procedure for the 0V line.

#### I/O Circuit Diagram

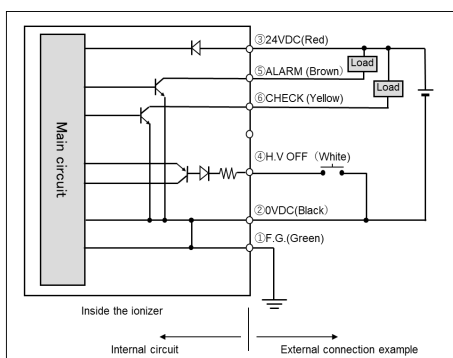

\*②DC0V and ①F.G are connected internally.

\*①-⑥ show the main unit pin number.

\* Note in parentheses ( ) shows the lead wire color in the power signal cable.

\* Use a no-voltage contact point or NPN open collector to connect ③H.V OFF. (when ② 0VDC shorted, discharge OFF)

\* When discharge OFF (when ③ H.V OFF and ② 0VDC shorted), H.V LED goes OFF.

No.	Signal	Function
①	F.G.	Functional earth (with a grounding resistance of 100Ω or less)
②	0VDC	Power 0V and output 0V
③	24VDC	Power input 24VDC±5%
④	H.V OFF	Discharge OFF when shorted at ②
⑤	ALARM	Contact point output when performance malfunction occurs (a contact point 24VDC 50 mA MAX)
⑥	CHECK	Contact point output when abnormal discharge occurs (a contact point 24VDC 50 mA MAX)

- 2) When using the AC adapter, please wire according to the connection diagram shown below.

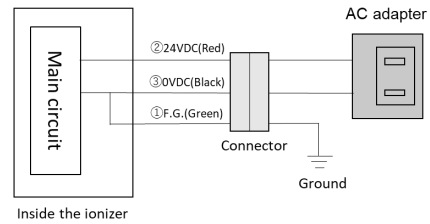

- Please use the "Mini-Clamp Wire Mount Plug (3-pin, Male)" included with the AC adapter.

- Cut the soldered portion of the power signal cable. Insert the lead wires into the holes in the cover according to the table below. (The insertion depth is approximately 9mm)

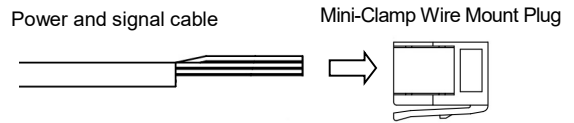

- Using a hand tool such as pliers, carefully clamp the cover and the mount plug body together to crimp them, taking care not to detach the lead wires.

Female connector (AC adapter side)		Male connector (Power and signal cable side)		
Pin No.	Signal	No.	Signal	Lead wire color
1	24VDC	③	24VDC	Red
2	0VDC	②	0VDC	Black
3	F.G.	①	F.G.	Green

- After crimping, connect to the mount plug (3-pin, female) on the AC adapter side.
- Ensure the earth cable (green wire) on the AC adapter side is grounded.

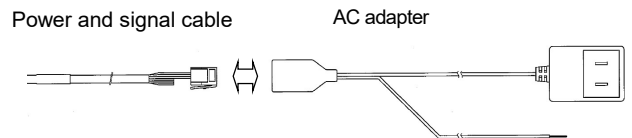

\*The 0V (AC adapter output) and F.G. (Frame Ground / Earth cable) are connected inside the main unit. Incomplete grounding will lead to a degradation of the static elimination performance.

- Connect the AC adapter to the power supply (100V -240VAC 50/60Hz) .

#### ⚠ CAUTION

The abnormality output circuit of this product will be active about one second after the power is switched on. Sufficient care should be taken to design an error detection circuit during installation.

When the power to the main unit of the ionizer is switched ON immediately after being switched OFF, an abnormality output may occur. When performing such an operation, be sure to wait for a period of at least one second after switching off.

When the ionizer main unit is switched OFF, an abnormality output may occur. Pay careful attention to the design of the error detection circuit not to detect the ionizer's abnormality output for a one-second period after the power supply to the ionizer main unit is switched OFF.

### 6.3 Air Tubing

- 1) Connect air tubes (outer diameter  $\phi 4$  mm) to the DTY-ELK01F main unit air fittings.  
For DTY-ELK01F-L, use fittings that match the tubing used (port size: Rc1/8).
- 2) Use a regulator to connect the air tube to the air source.

#### WARNING

Always supply air before switching ON the power, and use within the specified pressure range.

#### CAUTION

Always clean piping materials before installation by performing an air blow (flushing) or washing to remove shavings, cutting oil, and foreign matter from inside the pipe. If chips, sealant tape, rust, or other debris generated during piping work are introduced, they can cause malfunctions such as clogging or leakage.

DTY-ELK01F-L (low dust type) undergoes clean washing with clean air and clean packaging prior to shipment; however, minute particles may be generated due to the effects of vibration during transport. After unpacking this product, please ensure thorough cleaning using air blow (flushing), taking into consideration the operational rules and safety requirements of your working environment (cleanroom environment).

When connecting or replacing fittings to the DTY-ELK01F-L (low dust type), please hold the hexagonal section of the female thread (Rc1/8). Applying excessive force to the main body may cause damage. (Recommended tightening torque: 4.5 to 6.5 N · m)

When installing and piping the filter "DTY-ZKF40C," ensure the operating pressure is 0.05 MPa or higher. The ionizer's performance may not be fully realized otherwise.

## 7. Operating

### 7.1 Steps When Starting Operation

- 1) Check that the nozzle and discharge needle unit are correctly connected to the ionizer.
- 2) Check the ionizer wiring and air tubing.
- 3) Supply air to the unit from the air equipment that is being used.
- 4) Supply 24VDC power to the unit. The PWR LED and H.V LED on the unit light up and electrostatic elimination begins.
  - \* If the optional power adapter is used, supply 100-240VAC, 50/60 Hz.
  - \* When using external controls (H.V OFF) to control the unit, the H.V LED goes OFF when discharge is OFF.
  - \* Use the input power side (24VDC side) to switch power ON/OFF.

#### WARNING

Take soundproof measures, such as wearing earplugs, when working at close proximity to the unit.

#### CAUTION

When used with intermittent blowing, the static elimination time and ion balance may be degraded compared to continuous blowing.

### 7.2 Steps When Stopping Operation

- 1) Stop the supply of power to the unit.
- 2) Stop the supply of air.

#### CAUTION

If the PWR LED is not illuminated or if the CHK LED or ALM LED lights up, immediately shut off the power and air, and see "6. Installation, Wiring and Tubing" in this manual. If problems still do not resolve, see "8. Maintenance" and "9. Troubleshooting" in this manual.

## 8. Maintenance

If the discharge needle is soiled, the electrostatic elimination effects will be reduced. Periodically clean the discharge needle and surrounding area to maintain performance.

<Discharge needle unit cleaning method>

- 1) Rotate the discharge needle unit counterclockwise, and pull it from the main unit.

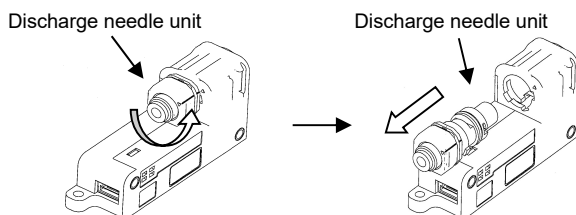

- 2) Rotate the discharge needle unit bushing counterclockwise, and remove the bushing.

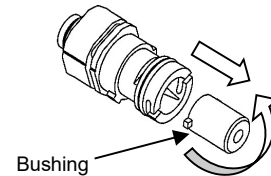

#### CAUTION

The discharge needle unit should be attached or removed by hand; do not use tools such as a wrench. Using tools may cause damage to the main unit or the discharge needle unit itself.

Do not apply excessive force when removing the bushing from the discharge needle unit.  
The discharge needle unit could be damaged.

When replacing the discharge needle unit, use the specified discharge needle unit. Discharge needle units are specifically designed for each type.  
You can determine the correct discharge needle unit by its color.

- 3) Clean the discharge needle and the bush of the removed discharge needle unit using a cotton swab moistened with alcohol (such as IPA).

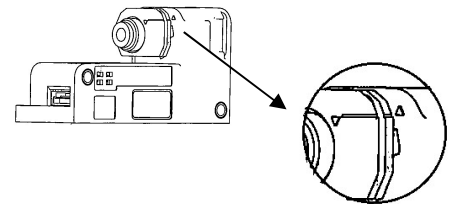

- 4) After drying the unit carefully with anhydrous alcohol, reassemble the discharge needle unit onto the main unit in reverse sequence to removal.  
At this time, rotate until the  $\Delta$  mark on the side of the main unit is aligned with the  $\Delta$  mark on the discharge needle unit.

#### WARNING

As the tip of the discharge needle is very sharp, care is needed when removing the discharge needle and during cleaning. The needle tip can cause injury. In addition, be extremely careful to avoid bending or breaking the discharge needle. Performance will be affected.

Securely attach the bushing and the discharge needle unit.  
If not securely fixed in place, performance will be affected, and the discharge needle unit may become loose during use, causing damage to the product and equipment.

#### CAUTION

To maintain performance, be sure to perform cleaning of the discharge needle and the surrounding area periodically. Performance will be affected, and lack of cleaning may cause damage to equipment and workpieces.

When performing maintenance, always disconnect the connection cables before proceeding.

When using alcohol or similar substances, make sure that there is adequate ventilation. In addition, always thoroughly dry off the alcohol after using it for cleaning, and check that none has spilled on to the main unit.

Because it can result in damage to the main unit, absolutely never use a wire brush for cleaning.

## 9. Troubleshooting

If product operation appears to be abnormal, immediately shut off the power to the main unit, disconnect the connection cable from the main unit's power connection terminal, and check the items in this section. If the abnormal situation continues, it may mean that a breakdown has occurred. Contact the outlet (the agency) at which you purchased the product, or the nearest Koganei service station.

#### The PWR LED does not light up.

→ Verify that the wiring and power source are connected correctly.

#### The PWR LED lights up but the H.V LED does not.

→ Verify that the H.V OFF terminal is not shorted.

#### CHK LED and ALM LED are illuminated.

→ Verify that the unit is securely grounded.

→ Verify whether the discharge needle is soiled or damaged, and whether the surrounding area is soiled. If it is soiled, see "8. Maintenance" in this manual, and perform maintenance or replacement of the discharge needle unit.

### **No electrostatic elimination effect**

- Verify that ionized air is blown to the object eliminating static electricity.
- Verify whether the discharge needle is soiled or damaged, and whether the surrounding area is soiled. If it is soiled, see "8. Maintenance" in this manual, and perform maintenance or replacement of the discharge needle unit.

### **Any other abnormal condition**

If any other abnormal condition has been observed, immediately turn off the power from the product, and please contact the outlet (the agency) at which you purchased the product, or the nearest Koganei service station.

## **10. Consumables and Optional Parts**

- Discharge needle unit : DTY-ZKFEM (standard type)  
DTY-ZKFEML (low-dust type)
- Replacement bushing : DTY-ZKFEB
- Power and signal cable : DTY-ZKFDSC
- AC adapter : DTY-ZKFPS
- Shower nozzle : DTY-NZKF-SW60 (standard type)  
DTY-NZKF-SW60L (low-dust type)
- Controller : DTY-ZKCR
- Controller unit : DTY-ZKCRU (Unit with solenoid valve)

- \* Before using the product, refer to the "Safety Precautions (Common to All Ionizers) and Handling Instructions and Precautions (Common Precautions)" in the Static Electricity Removal Unit Ionizers catalog and on our website, regarding precautions for and how to use the product.

- \* For inquiries about the product, contact our Overseas Department noted below.



**KOGANEI CORPORATION**

**OVERSEAS GROUP**

Takanawa Office, 3F, PMO Takanawa Gateway, 2-9-17,

Takanawa, Minato-Ku, Tokyo, 108-0074, Japan

Tel: +81-3-6721-7478 Fax: +81-3-5424-1021