

KOGANEI

iB-Move Support Software

Instruction Manual Ver. 1.1

Contents

1. Outline of software

1-1. Outline	2
1-2. Operating environment conditions	2

2. Preparing for use

2-1. Preparations	3
2-2. Connecting the USB-RS485 converter to the PC.....	4
2-3. Connecting the USB-RS485 converter to the controller	5

3. Software startup

3-1. Procedure for software startup to COM port selection	6
---	---

4. Operations

4-1. Basic operation procedure	7
4-2. Support software operation window	8
4-2-1. Operation window	8
4-2-2. Description of operation window functions	8
4-3. Operation methods in the setting area	11
4-3-1. Point/parameter data setting window.....	11
4-4. Operation methods in the operation area	13

※ For details on the main unit and controller, refer to the instruction manual for the iB-Move series main unit and controller IBM2A-C.

1. Outline of software

1-1. Outline

This software communicates with the iB-Move controller, and displays the controller settings, trial operation/operation states of the actuator and other information.

■ Setting/saving data

Points (operation mode, position, speed, acceleration, deceleration, pressing level), parameters and other information are input and edited, and then saved to file.

■ Trial operation

Operation is started, origin return executed and current position displayed based on preset points and parameters.

■ Indicators

These indicate I/O signals, current position, alarms, errors, communication status, and other information.

1-2. Operating environment conditions

■ Target actuator/controller

- Actuator Model: **IBM2A5** x --/**IBM2A10** x --/**IBM2A16** x --
- Controller Model: **IBM2A-C1-A1**

■ Computer operating environment

- OS
Windows 2000, Windows XP
- Computer system
 - Hardware requirements: PC with a Pentium CPU
 - Software requirements: Microsoft .NET Framework Version 2.0 or later^{Note 1}
Windows Installer 3.0 or later^{Note 2}
Internet Explorer 5.0 or later
 - Memory: At least 64 MB of available memory
 - Free space on hard disk: At least 50 MB^{Note 3}
 - Display: Min. resolution 800 x 600 (1024 x 768 or more recommended)
 - USB port: USB port is available

Note 1: When Microsoft .NET Framework Version 2.0 or later is not installed, execute the file "dotnetfx.exe" on the CD. Installation starts after you agree to the terms of the licensing agreement.

2: When Windows Installer 3.0 or later is not installed, execute the file "WindowsInstaller-KB893803-v2-x86.exe" on the CD. Installation starts after you agree to the terms of the licensing agreement.

3: At least 300 MB of free space is required on the hard disk to install "dotnetfx.exe" and "WindowsInstaller-KB893803-v2-x86.exe".

2. Preparing for use

2-1. Preparations

■ How to install the support software

Copy the file "IBM2A_Series. Support Soft English_Ver_1.exe" to a suitable folder on the hard disk and double-click the file.

After the file is unzipped, select "setup.exe" to execute the setup.

The installation program is started up.

Follow the on-screen instructions to install the software.

Note 1: If an old version is installed, first uninstall the old version before executing the setup.

Note 2: Login with administrator's rights to install the software.

Enter the login name using single-byte alphanumeric characters.

■ How to uninstall the support software

① At [Settings - Control Panel]-[Add and Delete Applications] in the Windows menu, select "iB-Move_SupportSoft" from the list of programs, and click the [Add and Delete] button.

② The deletion program is started up. Follow the on-screen instructions to delete the software.

2-2. Connecting the USB-RS485 converter to the PC

■ How to install the driver

- ① Connect the PC to the USB-RS485 converter using the USB cable.
The screen shows the following after connection.
Select "Install from list or specified directory" and click the [Next] button.



- ② Select "Search for optimum driver in next directory" and click [Browse].

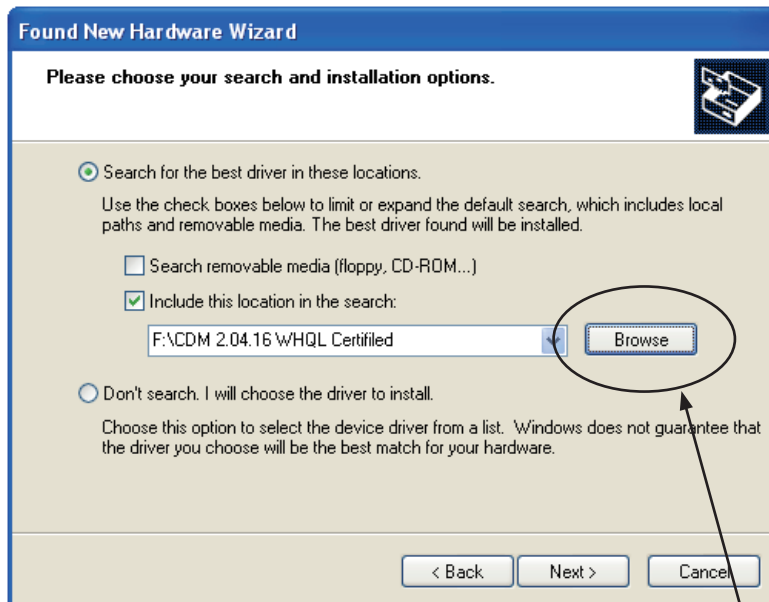

Browse button

- ③ Select the "CDM 2.04.16 WHQL Certified" folder in the file that was unzipped in "2-1 Preparations."
- ④ Click the [Next] button. Installation is started and installation of the driver is completed.

2-3. Connecting the USB-RS485 converter to the controller

- Connect the cable connector from the USB-RS485 converter to the "COM" connector on the controller.

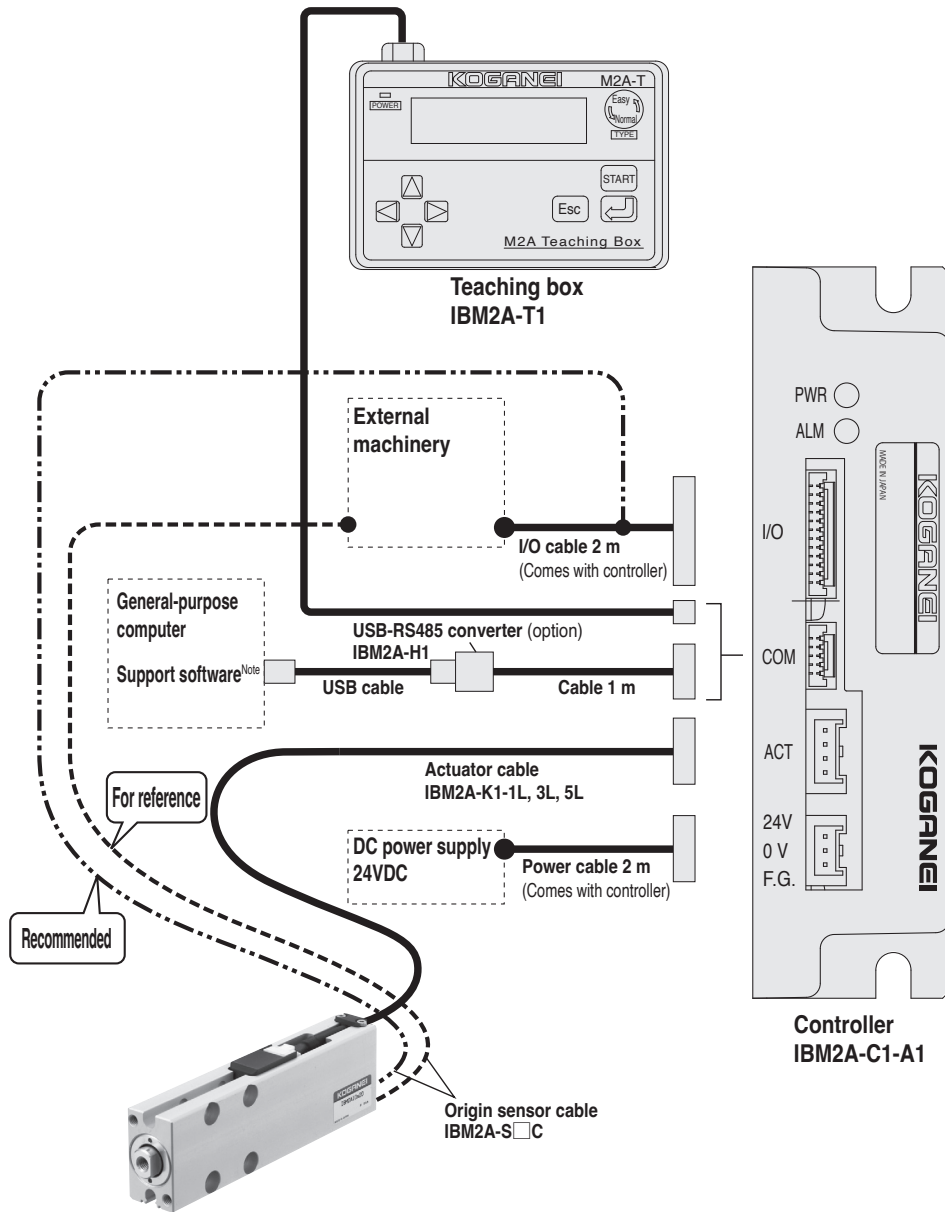

Note: A USB-RS485 converter is required to use the computer support software that comes with the product.

3. Software startup

3-1. Procedure for software startup to COM port selection

Double-click the file "iB-Move_SupportSoft.exe" to start up the software.

First, select the communication port.

Since this support software automatically searches for and displays the COM port to which the USB is connected when the software is started up, select the COM port of the USB-RS485 converter from the pulldown menu.

After selecting the COM port, click the **SET** button.

To use this software without the connection, select "Not connected".

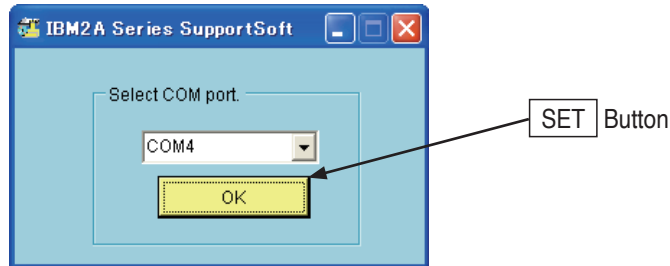

■ Online: When "COM port" is selected

Connect the USB-485 converter to the controller beforehand, and then turn the controller on.

After selecting the COM port, the point data and parameter data of the currently connected controller are automatically acquired.

If data cannot be acquired, the model selection window is displayed. For details on the model selection window,

see the following item "Offline: When "Not connected" is selected."



To "4-2 Support software operation window"

■ Offline: When "Not connected" is selected

After selecting COM port: "Not connected", the model selection window is displayed.

Select the main unit model.

When "Not connected" is selected, points and parameters can only be edited.

After selecting "Not connected", click the **SET** button.

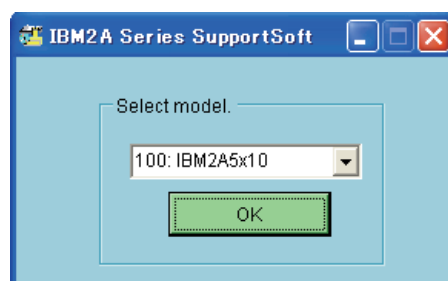

To "4-2 Support software operation window"

4. Operations

4-1. Basic operation procedure

The following describes the procedure for basic operations.

- ① When the actuator number is not for the actuator to which the controller is connected, initialize parameters by [Tools]-[Initialization (parameters)].

Note: Be sure to set the actuator number for the connected actuator.

Before the actuator and controller are shipped from the factory as a set, the parameters are initialized to match the actuator number of the set.

- ② From the parameter field in the setting area, set the parameters to match the operating conditions.
- ③ From the point field in the setting area, click [PNT] and input the point data.
- ④ Send the points and parameters by [Tools]-[Send].
- ⑤ Execute origin return by the [Origin return] button in the operation area.
- ⑥ Operate by the [GO-P0] button or [GO-P1] button in the operation area.

Caution: When the actuator type selection field is changed, the support software window is changed but the actuator type for the controller is not changed.

Caution: When operating the main unit in the operation area, be sure to provide an external emergency stop or stop function.

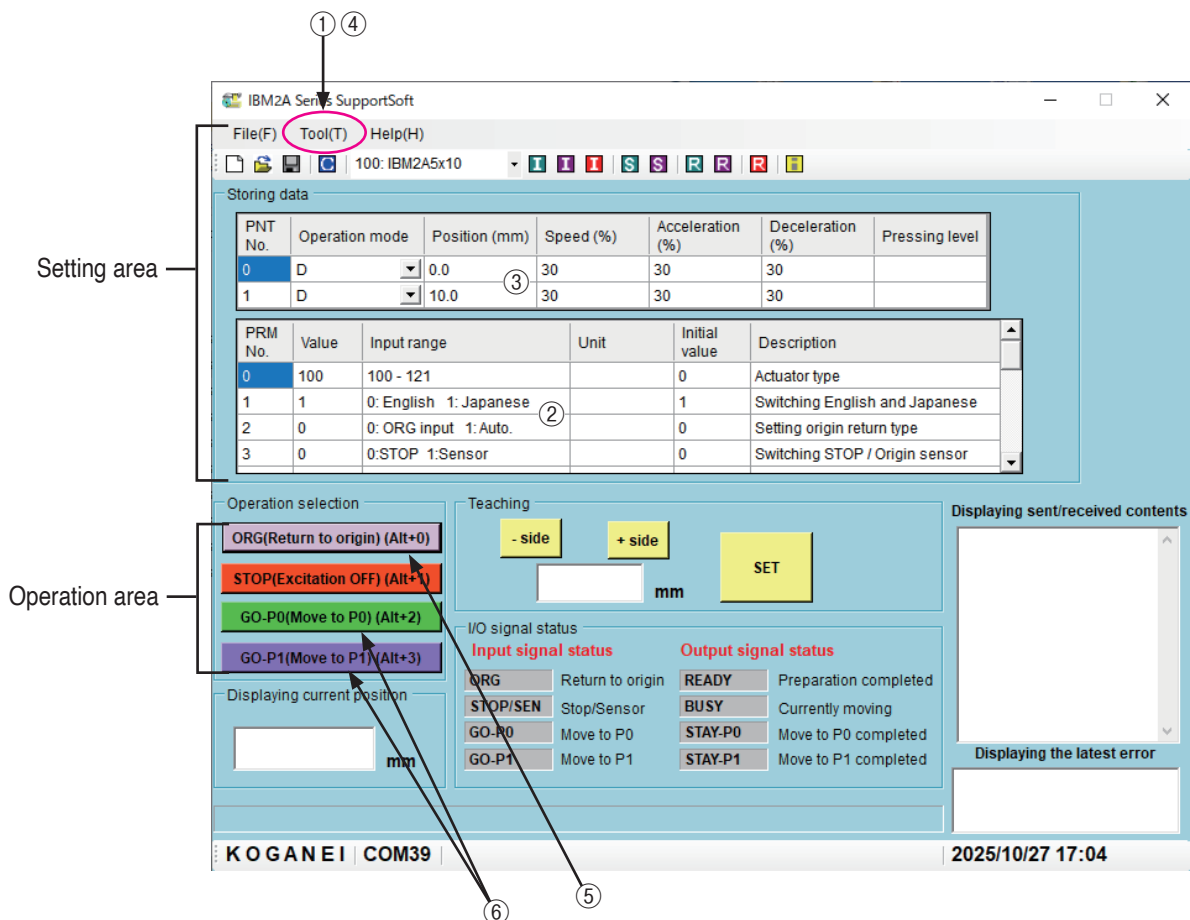

4-2. Support software operation window

The following describes the support software operation window.

4-2-1. Operation window

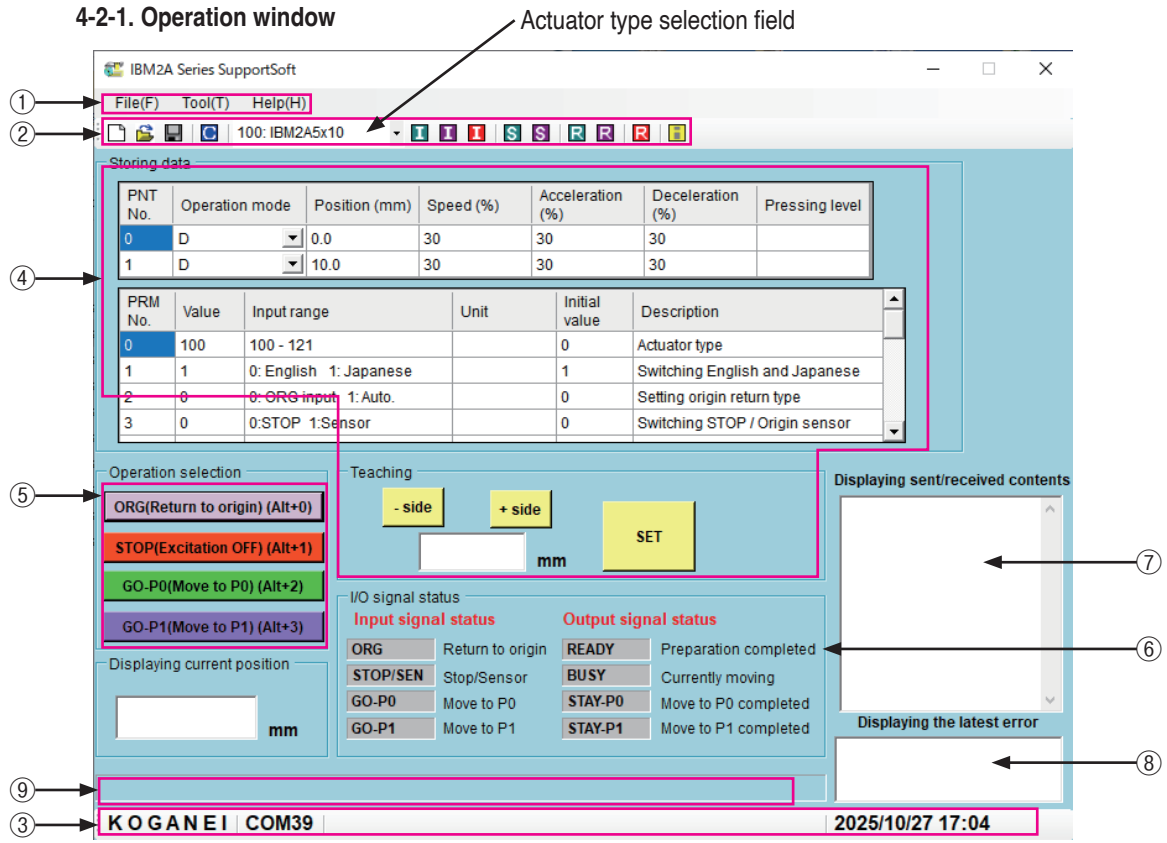

- | | |
|--------------------|--------------------------------|
| ① : Menu bar | ⑥ : I/O monitor area |
| ② : Tool bar | ⑦ : Communication display area |
| ③ : Status bar | ⑧ : Alarm/error display area |
| ④ : Setting area | ⑨ : Send/receive status bar |
| ⑤ : Operation area | |

4-2-2. Description of operation window functions

No.	Name	Meaning
①	Menu bar	<p>The pulldown menu number 1 layer menu is displayed.</p> <ul style="list-style-type: none"> ■ File ■ Tools ■ Help <p>Three pulldown menus are displayed on the menu bar by individual function.</p> <ul style="list-style-type: none"> ■ File <ul style="list-style-type: none"> • New: Deletes the setting values in the window to return it to its initial state. • Open: Reads setting values from a saved file to display them in the window. The actuator type selection field is changed according to the opened file. The operation window (parameter defaults/input range, etc.) also is changed according to the actuator type. • Save: Saves setting values (point/parameter data). • Exit: Exits the software.

No.	Name	Meaning														
①	Menu bar	<p>■ Tools</p> <ul style="list-style-type: none"> • Send (point): Sends points to the controller. • Send (parameter): Sends parameters to the controller. • Receive (point): Receives points from the controller. • Receive (parameter): Receives parameters from the controller. The actuator type selection field is changed to the received actuator type. The operation window (parameter defaults/input range, etc.) also is changed according to the actuator type. • Initialize: Initializes the point/parameter/error history. The actuator type selection field is also changed when parameters are initialized. The operation window (parameter defaults/input range, etc.) is also changed according to the actuator type. <table border="1"> <thead> <tr> <th>Model</th> <th>IBM2A5 x 10- □-□</th> <th>IBM2A5 x 20- □-□</th> <th>IBM2A10 x 20- □-□</th> <th>IBM2A10 x 30- □-□</th> <th>IBM2A16 x 32- □-□</th> <th>IBM2A16 x 48- □-□</th> </tr> </thead> <tbody> <tr> <td>Actuator number</td> <td>100</td> <td>101</td> <td>110</td> <td>111</td> <td>120</td> <td>121</td> </tr> </tbody> </table> <ul style="list-style-type: none"> • COM setting: Resets the communication port to be used for communication with the controller. (3-1. Procedure for software startup to COM port selection) • Error history display: A history of the latest errors to have occurred that is held internally on the controller is displayed. (This is displayed in the ⑧ alarm/error display area.) <p>■ Help</p> <ul style="list-style-type: none"> • Displays the version information of the controller and support software. 	Model	IBM2A5 x 10- □-□	IBM2A5 x 20- □-□	IBM2A10 x 20- □-□	IBM2A10 x 30- □-□	IBM2A16 x 32- □-□	IBM2A16 x 48- □-□	Actuator number	100	101	110	111	120	121
Model	IBM2A5 x 10- □-□	IBM2A5 x 20- □-□	IBM2A10 x 20- □-□	IBM2A10 x 30- □-□	IBM2A16 x 32- □-□	IBM2A16 x 48- □-□										
Actuator number	100	101	110	111	120	121										
②	Tool bar	<p>Handy buttons used as shortcuts for menu commands</p> <p>[File]</p> <p> New Open^{Note 1} Save</p> <p>[Communication]</p> <p> COM setting</p> <p>[Initialize]</p> <p> Initialize: Points (dark green)</p> <p> Initialize: Parameters (purple)^{Note 2} <Actuator type selection field^{Note 3}></p> <p> Initialize: Error history (red)</p> <p>[Send]</p> <p> Send: Points (dark green) Send: Parameters (purple)</p> <p>[Receive]</p> <p> Receive: Points (dark green) Receive: Parameters (purple)^{Note 4}</p> <p> Receive: Error history (red)</p> <p>[Other]</p> <p> Acquiring version information</p> <p>Note 1: The actuator type selection field is changed according to the opened file. The operation window (parameter defaults/input range, etc.) is also changed according to the actuator type.</p> <p>2: Select the actuator type to be initialized from the actuator type selection field on the right of the button.</p> <p>3: When the actuator type selection field is changed, the operation window (parameter defaults/input range, etc.) is also changed.</p> <p>4: The actuator type selection field is changed to the received actuator type. The operation window (parameter defaults/input range, etc.) is also changed according to the actuator type.</p>														

4-3. Operation methods in the setting area

The following describes the details of the setting area in the operation window.

4-3-1. Point/parameter data setting window

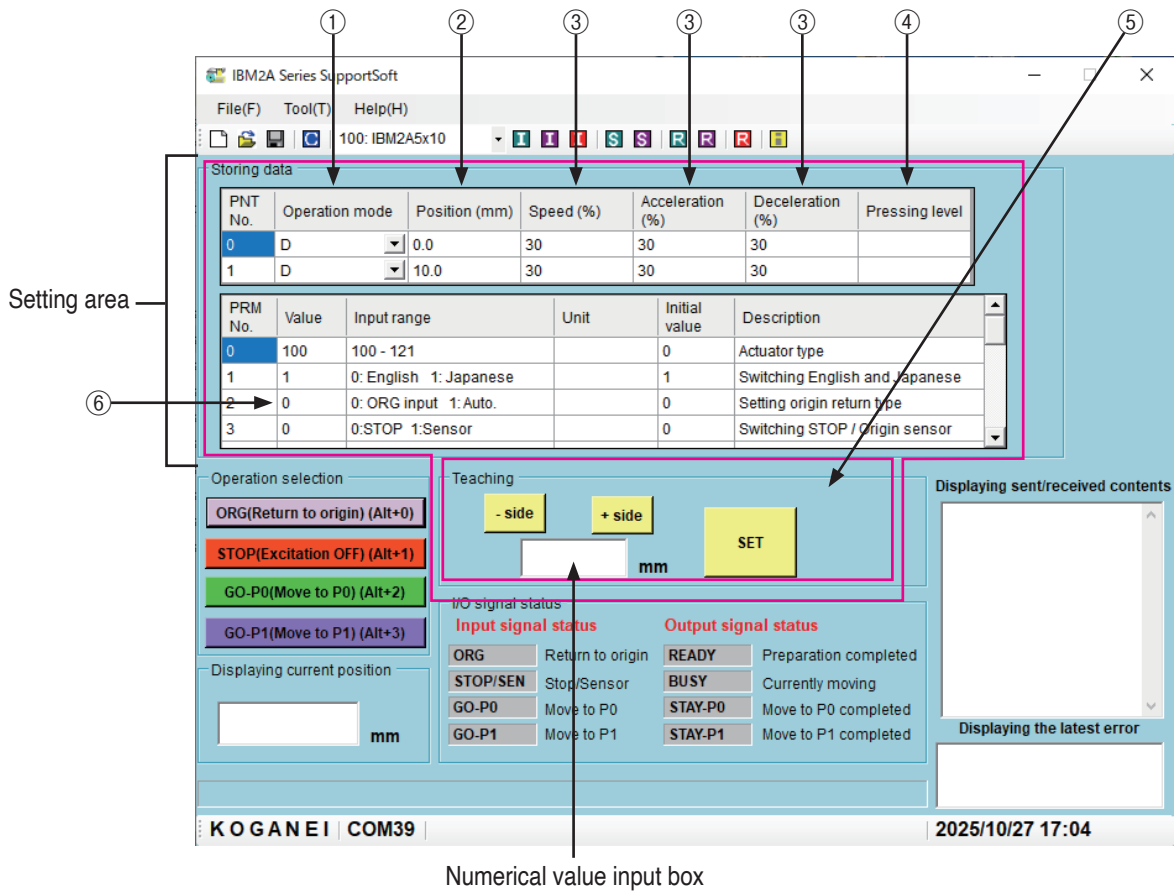

- ① : Operation mode
- ② : Position
- ③ : Speed/acceleration/
deceleration
- ④ : Pressing level
- ⑤ : Teaching setting area
- ⑥ : Parameters

[Description of function]

No.	Name	Operation method	Remarks												
①	Setting mode	<ul style="list-style-type: none"> Sets the operation mode of each point. <p>[Input Method]</p> <ul style="list-style-type: none"> Setting cell input <p>Input directly in the mode cell or select from the mode cell. The table below shows the items that can be input in each mode.</p> <table border="1" style="margin-left: 20px;"> <thead> <tr> <th>Mode</th> <th>Position</th> <th>Speed / Acceleration / Deceleration</th> <th>Pressing level</th> </tr> </thead> <tbody> <tr> <td>D</td> <td>Can be input</td> <td>Can be input</td> <td>—</td> </tr> <tr> <td>H</td> <td>Can be input</td> <td>Can be input</td> <td>Can be input</td> </tr> </tbody> </table>	Mode	Position	Speed / Acceleration / Deceleration	Pressing level	D	Can be input	Can be input	—	H	Can be input	Can be input	Can be input	<p>D: Positioning (absolute position) H: Pressing</p>
Mode	Position	Speed / Acceleration / Deceleration	Pressing level												
D	Can be input	Can be input	—												
H	Can be input	Can be input	Can be input												

No.	Name	Operation method	Remarks																		
②	Position	<ul style="list-style-type: none"> Inputs the position of each point. There are two ways of inputting the position. <p>[Input Method]</p> <ul style="list-style-type: none"> Direct input in setting cell Directly input the numerical value in the "Position" cell. After inputting, set with the ENTER key. Teaching playback Operate the actuator by the teaching playback buttons - side + side in the teaching setting area and set the position. <p><Procedure></p> <ul style="list-style-type: none"> Teaching setting area Set the position by the teaching playback buttons. If the origin return command appears, follow the on-screen instructions. The position is copied to the position cell of the selected number by the SET buttons. 	<p>☆ After setting numerical values, be sure to click the SET button.</p> <p>☆ <Setting input range></p> <table border="1"> <tr> <td>Model</td> <td>IBM2A5 x 10 -□-□</td> <td>IBM2A5 x 20 -□-□</td> </tr> <tr> <td>Range</td> <td>0.0 to 10.0 mm</td> <td>0.0 to 20.0 mm</td> </tr> </table> <table border="1"> <tr> <td>Model</td> <td>IBM2A10 x 20 -□-□</td> <td>IBM2A10 x 30 -□-□</td> </tr> <tr> <td>Range</td> <td>0.0 to 20.0 mm</td> <td>0.0 to 30.0 mm</td> </tr> </table> <table border="1"> <tr> <td>Model</td> <td>IBM2A16 x 32 -□-□</td> <td>IBM2A16 x 48 -□-□</td> </tr> <tr> <td>Range</td> <td>0.0 to 32.0 mm</td> <td>0.0 to 48.0 mm</td> </tr> </table> <p>(Enter down to 1 digit past the decimal point within the allowable stroke range.)</p>	Model	IBM2A5 x 10 -□-□	IBM2A5 x 20 -□-□	Range	0.0 to 10.0 mm	0.0 to 20.0 mm	Model	IBM2A10 x 20 -□-□	IBM2A10 x 30 -□-□	Range	0.0 to 20.0 mm	0.0 to 30.0 mm	Model	IBM2A16 x 32 -□-□	IBM2A16 x 48 -□-□	Range	0.0 to 32.0 mm	0.0 to 48.0 mm
Model	IBM2A5 x 10 -□-□	IBM2A5 x 20 -□-□																			
Range	0.0 to 10.0 mm	0.0 to 20.0 mm																			
Model	IBM2A10 x 20 -□-□	IBM2A10 x 30 -□-□																			
Range	0.0 to 20.0 mm	0.0 to 30.0 mm																			
Model	IBM2A16 x 32 -□-□	IBM2A16 x 48 -□-□																			
Range	0.0 to 32.0 mm	0.0 to 48.0 mm																			
③	Speed/acceleration/deceleration	<ul style="list-style-type: none"> Sets the speed/acceleration/deceleration of each point. <p>[Input Method]</p> <ul style="list-style-type: none"> Setting cell input Directly input numerical values to the "Speed", "Acceleration" or "Deceleration" cells. After inputting, set with the ENTER key. 	<p>☆ The speed numerical value becomes the ratio to the maximum speed. The deceleration becomes the ratio to the maximum acceleration/deceleration.</p> <p>☆ <Setting input range> 1 to 100 (%)</p>																		
④	Pressing level	<ul style="list-style-type: none"> Sets the pressing level of each point. <p>[Input Method]</p> <ul style="list-style-type: none"> Setting cell input Directly input the numerical value in the "Pressing level" cell. After inputting, set with the ENTER key. 	<p>☆ <Setting input range> Mode H only: 1 to 10</p> <p>※ For details, refer to the main unit Instruction manual.</p>																		
⑤	Teaching setting area	<ul style="list-style-type: none"> Sets the teaching settings. <p>*See ② Position setting item.</p>																			
⑥	Parameters	<ul style="list-style-type: none"> Displays and changes parameters that can be set. The "Value" cell is the currently set value. <p>[How to change parameters]</p> <p>Select the cell to the value of the parameter to change, and input numerical values directly. After inputting, set with the ENTER key.</p>	<p>☆ <Setting input range> Input within the numerical value of the setting range column.</p> <p>☆ Parameter No. 0 (actuator type) cannot be changed from the parameter data setting window. Do this by [Tools]-[Initialization (parameters)].</p>																		

4-4. Operation methods in the operation area

The following describes the details of the operation area in the operation window.

After completing the various settings (points/parameters), send the data to the controller by [Tools]-[Send (point)]/[Send (parameter)]. If the settings are left unspent, operation will not be according to the settings executed on the support software.

[Setting window]

The screenshot shows the IBM2A Series SupportSoft interface. The 'Storing data' table is as follows:

PNT No.	Operation mode	Position (mm)	Speed (%)	Acceleration (%)	Deceleration (%)	Pressing level
0	D	0.0	30	30	30	
1	D	10.0	30	30	30	

The 'PRM' table is as follows:

PRM No.	Value	Input range	Unit	Initial value	Description
0	100	100 - 121		0	Actuator type
1	1	0: English 1: Japanese		1	Switching English and Japanese
2	0	0: ORG input 1: Auto.		0	Setting origin return type
3	0	0:STOP 1:Sensor		0	Switching STOP / Origin sensor

The 'Operation selection' area contains buttons for ORG(Return to origin) (Alt+0), STOP(Excitation OFF) (Alt+1), GO-P0(Move to P0) (Alt+2), and GO-P1(Move to P1) (Alt+3). The 'I/O signal status' section shows input and output signal statuses. The 'Current position display box' is located below the operation selection buttons. The status bar at the bottom shows 'KOGANEI COM39' and the date '2025/10/27 17:04'.

Current position display box

① : Origin return button ③ : GO-P1 button
② : GO-P0 button ④ : STOP button

[Description of function]

No.	Name	Operation method	Caution
①	Origin return	<ul style="list-style-type: none"> Execute origin return. <p>Clicking the operation area - <input type="button" value="Origin return"/> button moves the actuator to the origin.</p>	☆ When the origin return position has been changed, movement is executed once to the default device origin and then to the newly set position.
②	GO-P0	<ul style="list-style-type: none"> Executes operation according to preset conditions. <p>Clicking the operation area - <input type="button" value="GO-P0"/> button executes operation according to the points and parameters of the PNT No. 0 selected in the setting area.</p>	
③	GO-P1	<ul style="list-style-type: none"> Executes operation according to preset conditions. <p>Clicking the operation area - <input type="button" value="GO-P1"/> button executes operation according to the points and parameters of the PNT No. 1 selected in the setting area.</p>	
④	STOP	<ul style="list-style-type: none"> Stops the actuator and turns excitation off. <p>Clicking the operation area - <input type="button" value="STOP"/> button stops the actuator and turns excitation off.</p>	☆ Origin return will not be completed, so execute origin return after inputting STOP.

Revision History

Ver 1.1

P5 Added origin sensor cable.

P7, P8, P11, P13 Updated support software screen images.

If parts of this document are unclear or you have technical questions, contact the following:

<<Inquiries>>

Koganei Corporation, Overseas Group

Takanawa Office, 3F, PMO Takanawa Gateway, 2-19-17, Takanawa, Minato-Ku, Tokyo, 108-0074, Japan

TEL : +81-3-6721-7478 FAX : +81-3-5424-1021

iB-Move Support Software

Instruction Manual

October, 2025 Ver. 1.1 X425105

©Koganei Corporation

Duplication or transfer of the content of this document in part or
in whole is forbidden.

URL: <https://www.koganei.co.jp>

E-mail: overseas@koganei.co.jp



KOGANEI CORPORATION

OVERSEAS GROUP

Takanawa Office, 3F, PMO Takanawa Gateway, 2-19-17,
Takanawa, Minato-Ku, Tokyo, 108-0074, Japan
Tel: +81-3-6721-7478 Fax: +81-3-5424-1021

KOGANEI INTERNATIONAL AMERICA, INC

39300 Civic Center Dr Suite 280 Fremont, CA 94538, U.S.A.
Tel: 510-744-1626 Fax: 510-744-1676

SHANGHAI KOGANEI INTERNATIONAL TRADING CORPORATION

Room 2606-2607, Tongda Venture Building No.1, Lane 600, Tianshan Road, Shanghai,
200051, China
Tel: 021-6145-7313 Fax: 021-6145-7323

KOGANEI KOREA CO., LTD.

Cosmo KT&G Bldg., 3F, Maesanno 2-ga, Paldal-gu, Suwon-si, Gyeonggi-do, 442-082, Korea
Tel: 031-246-0414

KOGANEI-PORNCHAI CO., LTD.

89/174 Moo 3, Vibhavadee Rangsit Road, Talad Bangkhen, Laksi, Bangkok, 10210, Thailand
Tel: 02-551-4025 Fax: 02-551-4015

KOGANEI ASIA PTE. LTD.

7500A Beach Road #06-320 The Plaza Singapore 199591
Tel: 65-6293-4512 Fax: 65-6293-4513