

KOGANEI

iB-Move
Main unit/Controller
IBM2A-C

Instruction Manual Ver. 1.5

Contents

1 Safety Precautions

- 1-1 Safety 2
- 1-2 Precautions 2

2 System Configuration

- 2-1 Overall system configuration 4
- 2-2 Accessories 4
- 2-3 Initial operation procedure 5

3 Main unit

- 3-1 Handling the main unit
 - 3-1-1 Precautions 6
- 3-2 Mounting
 - 3-2-1 Mounting the main unit 6
 - 3-2-2 Mounting a workpiece on the rod end ... 6
 - 3-2-3 About the origin sensor 7

4 Controller

- 4-1 Appearance, names and functions of parts ... 10
- 4-2 Installation and connecting to external devices
 - 4-2-1 Installing the controller 10
 - 4-2-2 Connecting the power supply 10
 - 4-2-3 Grounding 11
 - 4-2-4 Connecting to a PC 11
 - 4-2-5 Connecting to an actuator 11
 - 4-2-6 Connecting the I/O connector 11
- 4-3 I/O interface
 - 4-3-1 I/O connector signal table 12
 - 4-3-2 Details of input signals 12
 - 4-3-3 Details of output signals 13
 - 4-3-4 I/O circuit 13
 - 4-3-5 Timing charts 17
- 4-4 Setting the actuator number 19
- 4-5 Point data specifications 20
- 4-6 Parameters
 - 4-6-1 How to set parameters 21
 - 4-6-2 Description of parameters 22
- 4-7 List of messages
 - 4-7-1 Error messages 24

5 Troubleshooting

- 5-1 When an abnormality occurs 25
- 5-2 Action and remedy when an alarm occurs 25
- 5-3 Alarm specifications
 - 5-3-1 Alarm message list 25

6 Specifications

- 6-1 Main unit basic specifications 26
- 6-2 Controller basic specifications 26
- 6-3 Teaching box basic specifications 27

7 Dimensions

- 7-1 Main unit dimensions..... 28
- 7-2 Controller dimensions 32

8 Technical data

- 8-1 Thrust 34

1 Safety Precautions

Thank you for purchasing iB-Move.

This manual describes the features and how to use iB-Move.

Be sure to thoroughly read the content of this manual to ensure correct use.

1-1 Safety

Be sure to follow the safety-related instructions and precautions listed in this manual. Failure to take the required safety measures or mishandling not only might result in product malfunction or damage, but also might lead to injury or accidents for the user (installation personnel, operator or adjustment/inspection personnel).

1-2 Precautions

(1) Safety Precautions

- Persons using a pacemaker or other similar medical devices should maintain a distance of at least one meter [3.28 ft] away from the product. There is a possibility that the pacemaker will malfunction due to the strong magnet built into the product.
- The product, especially its rod section, uses a strong magnet, and you should never try to modify it in any way. It could result in abnormal operation leading to injury, electric shocks, fire, etc.
- The rod uses a strong magnet. Workpieces, tools, and metal components of magnetic materials in the vicinity can be drawn to the magnet, creating the risk of personal injury or damage to the machinery. Exercise sufficient caution while working.
- Be sure to fully implement shielding measures whenever using the product in the locations described below. Failure to do so creates the risk of abnormal operation, damage to machinery, or personal injury.
 1. Locations subject to large electric currents or strong magnetic fields
 2. Locations where static electricity and other noise is generated
 3. Locations that may be subject to radiation from radioactive emissions
 4. Locations where iron or other magnetic material particles or dust is generated or present in the air
- Keep floppy disks and other magnetic media and other electronic devices (watches, calculators, etc.) at least one meter [3.28 ft] away from the product. Failure to do so creates the risk of destruction of the data on the media or defective operation of electronic devices due to the magnetism of the product's magnet.
- The surface of this unit and its rod can become very hot during operation (ambient temperature plus 60 °C [140 °F] max.). While power is on and after cutting off the power supply, be sure to check carefully that the surface of the unit has cooled sufficiently before performing work, etc.
- Use only non-magnetic screws and washers to install the product.
- Depending on how this unit is mounted, the rod may drop under its own weight whenever the electrical power supply is turned off or a power outage occurs. Use safety circuits or design a system that prevents damage to machinery and personal injury.
- When performing return-to-origin (ORG input), the rod may move suddenly in the opposite direction. Take appropriate measures to avoid damage to the machinery and to ensure safety before starting.
- When mounting multiple main units in close proximity to each other, mount them so that the distance between them is the specified value or more. For details, see "3-2-1 Mounting the main unit."

(2) Automatic operation

- Provide interlocks to prevent the worker from being injured through contact with moving parts on iB-Move.

(3) Pinching of hands, etc.

- Take care to prevent your hands and other things from being pinched by moving parts when carrying, operating or teaching iB-Move.

(4) Use of the product in the presence of combustible gasses is prohibited

- iB-Move is not explosion-proof. Do not use the product in areas that include combustible gases, flammable dust, inflammable liquids, etc. Doing so could cause a fire or explosion.

(5) Use of the product in locations where there is a risk of electromagnetic interference is prohibited

- Do not use the product in locations where there is a risk of electromagnetic interference, electrostatic discharge, or radiowave interference. Doing so might cause a malfunction.

(6) Safety measures for tools and workpieces (pressing points, etc.)

- Design and make tools and workpieces so that hazards (expulsion of workpiece, etc.) caused by loss or fluctuation of drive power (motor power, air pressure, etc.) do not occur.
- If there is a risk of an object being pressed by tools and workpieces flying out or dropping, adopt appropriate safety measures for the size, mass, temperature, and chemical properties of the object.

(7) Precautions for inspection of controller

- Turn off the controller and cut off the power supply during inspections before touching external terminals and connectors on the controller to prevent electric shock.
- Never touch the inside of the controller.

(8) Remedies when iB-Move is damaged or trouble occurs

- Continued use of iB-Move if it is damaged or trouble has occurred is dangerous. Stop use immediately and contact Koganei.

Damage/Trouble	Potential Danger
Machine harness, motor lead damage	Electric shock, iB-Move malfunction
iB-Move exterior damage	Damaged parts flying out while iB-Move is operating
iB-Move operation trouble (out-of-position, vibration, etc.)	iB-Move malfunction

(9) Be careful of touching hot parts on the main unit and controller

- Do not touch the main unit and controller after automatic operation because they are hot and may cause burns. If you need to touch them, such as for an inspection, turn the controller off, let them cool, and confirm they are cool before touching them.

(10) Protective ground

- To protect the human body from possible current leaks and prevent equipment malfunction caused by noise, be sure to ground the iB-Move main unit with the F.G. screw (see 7-1 Main unit dimensions) and the controller with the connector F.G. terminal (see table in section 4-2-2). Class D grounding (max. grounding resistance 100 Ω) is recommended. Use electrical wire that is thicker than AWG14 (2 mm²) as the ground wire.

2 System Configuration

2-1 Overall system configuration

iB-Move is composed of the following main equipment

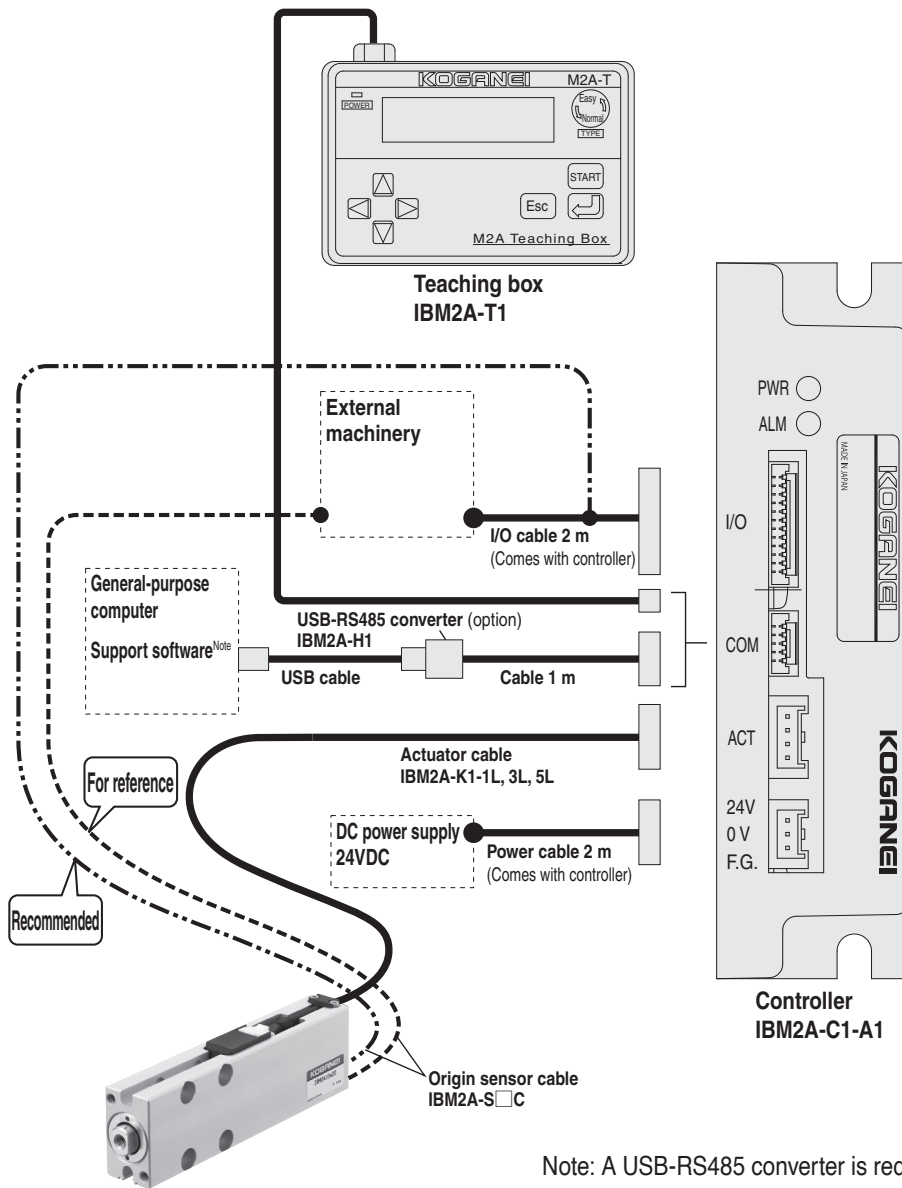

Note: A USB-RS485 converter is required to use the computer support software that comes with the product.

2-2 Accessories

- When -C1 (w/controller IBM2A-C1-A1) is selected, the following accessories are packaged with the controller IBM2A-C1-A1. Confirm at time of delivery that they are included.

IBM2A-C1-A1 accessories

Power cable	(1 pc)
I/O cable	(1 pc)
Instruction Manual (CD-R)	(1 pc)

- When -1L, -3L, -5L (w/actuator cable for connecting the iB-Move main unit and the controller) is selected, the actuator cable (-1L: 1 m cable, -3L: 3 m cable, -5L: 5 m cable) is packaged. Confirm at time of delivery that it is included.

2-3 Initial operation procedure

	Procedure	See Section	
Installation/ connections	Installation	3-2 4-2	
	↓		
	Connection	Connect the power supply, controller, actuator, and PC or teaching box.	4-1 4-2
	↓		
	Power on	4-2	
	↓		
Settings	Actuator number setting	Set the specified actuator number ^{Note 1}	4-4
	↓		
	Parameter changes	Set the parameters to match operating conditions.	4-6 ^{Note 2}
	↓		
	Point data input	Write point data suited to automatic operation.	4-5 ^{Note 2}
	↓		
	Trial operation	Check that operation is normal.	4-3
	↓		
Operation	Operation	Operate iB-MOVE by the GO-P0 or GO-P1 signal. In the case of continuous operation, control iB-MOVE from a programmable controller or other external equipment.	4-3

Note 1: When the actuator and controller are bought together as a set, the controller is shipped with the actuator number of the purchased actuator already set to the specified number

2: When the actuator and controller are bought together as a set, simple trial operation can be done using the initial data already set for the controller.

3 Main unit

3-1 Handling the main unit

3-1-1 Precautions

- (1) Avoid repeated or excessive bending or pulling of lead wires. Also, do not carry the main unit by its lead wires. Doing so might break the lead wires.
- (2) Do not subject the workpiece to external force while it is still attached to the main unit. Applying excessive external force might damage parts.
- (3) Operation restrictions
Operating conditions sometimes cause the linear motor in the main unit to heat up.
Use the linear motor within the rated operating temperature range (0 to 40°C [32 to 104°F]).
Use of the linear motor outside of this range might damage or burn out the motor.
- (4) The heat dissipation environment of installation materials sometimes causes the surface of the unit to become very hot. Make sure the surface has cooled down sufficiently before doing inspection and other work while the main unit is turned on or after it is turned off.

3-2 Mounting

3-2-1 Mounting the main unit

- (1) To prevent main unit heat buildup, be sure to mount it onto an item with the best possible heat conductivity in a location that has good heat dissipation properties.
- (2) Choose a flat surface as the mounting surface. Twisting or bending during mounting creates the risk of defective operation and loss of performance.
- (3) Note that a mounting surface that is scratched or dented can adversely affect mounting accuracy.
- (4) In cases where loosening of screws due to impact and/or vibration may be a factor, consider looseness prevention measures, etc.
- (5) When securing the main unit, use the front or bottom threads or the side counterbore holes.

Model	Screw size	Maximum tightening torque N·m [in. lbf]
IBM2A5	M3	0.63 [5.58]
IBM2A10	M4	1.5 [13.3]
IBM2A16	M5	3.0 [26.6]

- (6) Use only non-magnetic screws and washers for installation.
- (7) After installing cables on the main unit, be sure to install a cable holder.
- (8) To satisfy product specifications, mount so that the distance between them is no less than P shown below.

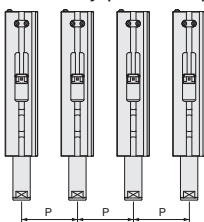

	mm [in]		
	IBM2A5	IBM2A10	IBM2A16
P	22 [0.87]	30 [1.18]	46 [1.81]

- (9) When using the product in an area where iron particles or other magnetic material particles or dust is generated or present, be sure to take adequate shielding measures.

3-2-2 Mounting a workpiece on the rod end

- (1) Whenever attaching a workpiece, be sure to use screws that are not longer than the thread depth. Operations may not be normal if screws that exceed the thread depth are used.
- (2) Use the rod flats when tightening screws for attaching the workpiece, and tighten within the allowable torque range.

Model	Screw size	Thread depth mm [in]	Maximum tightening torque N·m [in. lbf]
IBM2A5	M3	4.5 [0.177]	0.63 [5.58]
IBM2A10	M5	8 [0.315]	3.0 [26.6]
IBM2A16	M6	10 [0.394]	5.2 [46.0]

* For outside dimensions, see pages 23 and 24.

- (3) Use only non-magnetic screws and washers for installation.
- (4) Take care that the workpiece does not apply a lateral load to the rod over the allowable range.
- (5) The rod uses a strong magnet, which may magnetize the workpiece.

3-2-3 About the origin sensor

The rod returns to origin more smoothly when the origin sensor is used, compared to when it is not used.
We recommend the origin sensor when the workpieces are connected to the rod end in series.

(1) About the origin sensor

1. The origin sensor is a specialized sensor for detecting the origin of the iB-Move. Do not use it with any other type of machine.
2. The origin sensor's maximum operating temperature is 80°C. Control the operating environment (ambient temperature, mounting plate material, etc.) so the surface of the iB-Move does not exceed the maximum temperature during operation.
3. The origin sensor cannot be attached to the main unit by the female screw on the sensor mounting surface on the IBM2A5 .
4. Do the wiring according to the connection procedure in the example system configuration so there are no mistakes.

Recommended connection procedure: Procedure to connect the sensor's origin output and power source to the controller

Return to origin will be smooth.

The wiring is simple, but the output of the origin cannot be sent to the PLC.

Use the mini clamp wire mount plugs that are provided for the connections.

Connect the number 2 I/O cable to the sensor's output, number 11 to the sensor's 24 V, and number 12 to the GND.

(The I/O's 24 V (numbers 9 and 10) and the controllers drive power should be common.)

Reference connection procedure: Procedure to connect the sensor's origin output and power source directly to the customer's PLC

Return to origin will be smooth.

The wiring is complicated, but the output of the origin can be sent to the PLC.

Connect the sensor's output signal to the PLC's input side and connect that output to the controller's STOP/SEN input (be careful of the circuit configuration, program, etc.).

5. If the origin sensor is being used, the I/O interface's STOP input (excitation OFF) cannot be used.
6. Do not let the cable be pulled or bent excessively.
7. Set the controller's parameter number 3 to 1 to use the origin sensor.
Set the controller's parameter number 3 to 0 to not use the origin sensor.
The controller's parameter number 3 is set to 1 when the sensor is included in the order for the main unit.
8. Set the controller's parameter number 44 to 100 to use the main unit in a vertical orientation.
9. The cable holder provided must be used to fix the actuator cable. In addition, fix the sensor cable so that it is not exposed to excessive force.
10. **The position in which the origin sensor is installed must not be moved.**

(2) Origin sensor and relay connector connection procedure

Use the mini clamp wire mount plug to connect the origin sensor in the recommended circuit.

Crimp the connectors according to the following procedure.

[Caution]

Check to make sure that the connector cover (lead wire inlet) is sitting above the body of the connector. Note that a connector whose cover is even with the body of the connector cannot be used.



1. Wiring of the connector on the sensor side

Cut the cable to the required length.

Strip the outer covering of the cable, 50 mm [1.97 in] from the end, to expose the lead wires. Do not strip the insulation from the individual lead wires at this time.

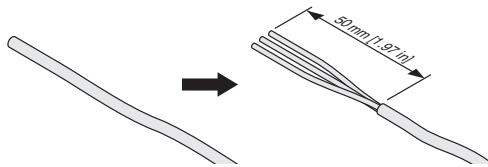

2. Insert the lead wires into the connector cover holes in accordance with the information in the table below. Check to make sure the lead wires are fully inserted as far as they will go by viewing the semi-transparent top cover of the connector (wire goes in about 9 mm [0.35 in].)

Note that supplying power while connections are incorrect will damage the control device you are using.

Pin No.	Male connector (controller side):		Female connector (Origin sensor side):	
	Gray	Black	Signal name	Wire color
1	+V	Brown	+V	Brown
2	SEN	Red 1	OUT	Black
3	0V	Red 2	0V	Blue

Male connector I/O connector cable connection procedure

Female connector Origin sensor cable connection procedure

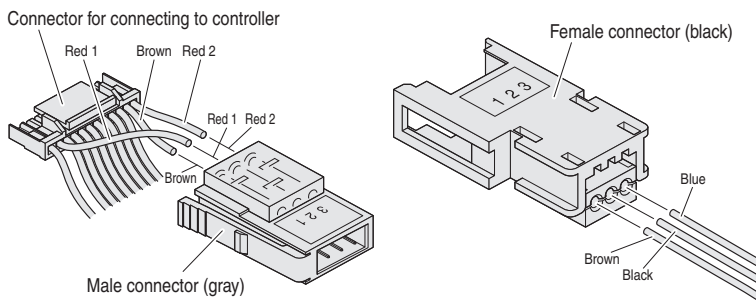

3. Taking care not to remove the lead wires from the connector, use pliers or some other type of hand tool to squeeze the cover and body of the connector until the cover is pressed into the body.

Do not apply pressure in excess of 980 N. Connection is complete when the cover is even with the connector body.

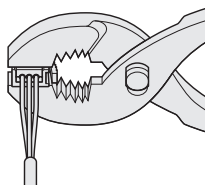

4. Double check to make sure that wiring is correct.

Mini clamp wire mount plug wire diameter compatibility table

Name	Size	Cross sectional area	Diameter of sheathing
Male connector	AWG 28 to 26	0.08 to 0.14 mm ²	φ0.8 to 1.0 mm [φ0.03 to 0.04 in]
Female connector	AWG 26 to 24	0.14 to 0.20 mm ²	φ0.8 to 1.0 mm [φ0.03 to 0.04 in]

Note: To disconnect the male and female connectors of the mini clamp wire mount plug, press down fully on the lock lever on the male side as you hold the connector and pull to disconnect. At this time, take care not to apply undue force to the lead wires.

- (3) If the customer installs the origin sensor
1. The customer needs to adjust the origin position precision if they install the origin sensor.
 2. The origin sensor detects the magnetic field of the magnet used to drive the actuator, so different sensors are used depending on the stroke of the actuator. Confirm the model when placing your order.
The correct position cannot be detected if the wrong model is installed.

Actuators that support **IBM2A-S1C**

- IBM2A5 × 20 • IBM2A10 × 20 • IBM2A16 × 32

Actuators that support **IBM2A-S2C**

- IBM2A5 × 10 • IBM2A10 × 30 • IBM2A16 × 48

3. The torque for tightening the sensor fixing screw is 0.1 N·m.

4. Position to install the origin sensor

Procedure to install the origin sensor

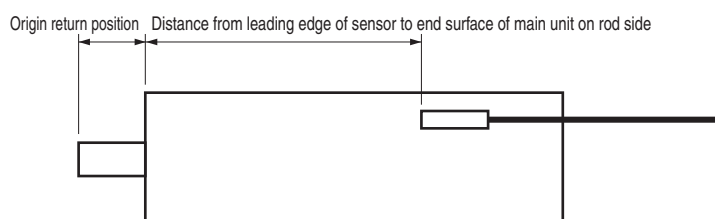

Unit: (mm) [in]

Main unit model	Sensor model	Distance from leading edge of sensor to end surface of main unit on rod side	Origin return position
IBM2A5 × 10	IBM2A-S2C	(36.5) [1.44]	5 ^{±1} [0.197 ^{±0.039}]
IBM2A5 × 20	IBM2A-S1C	(46) [1.81]	
IBM2A10 × 20	IBM2A-S1C	(49) [1.93]	5.5 ^{+0.5} ₋₁ [0.217 ^{+0.02} _{-0.039}]
IBM2A10 × 30	IBM2A-S2C	(59) [2.32]	
IBM2A16 × 32	IBM2A-S1C	(81.5) [3.21]	6 ^{+0.5} ₋₁ [0.236 ^{+0.02} _{-0.039}]
IBM2A16 × 48	IBM2A-S2C	(97.5) [3.84]	

Install the origin sensor in the position noted above.

4 Controller

4-1 Appearance, names and functions of parts

- ① Power LED
This LED lights when the power is on.
- ② Alarm LED
This LED indicates the controller state. (See table on right.)
- ③ I/O connector
This connector is used for connecting the I/O cable (provided) to connect to an external programmable controller or other device.
- ④ COM connector
This connector is used for connecting the controller to a PC or TB.
- ⑤ ACT connector
This connector is used for connecting the controller to the main unit.
- ⑥ Power connector
This connector is used for connecting the power cable (provided) to provide 24VDC power.

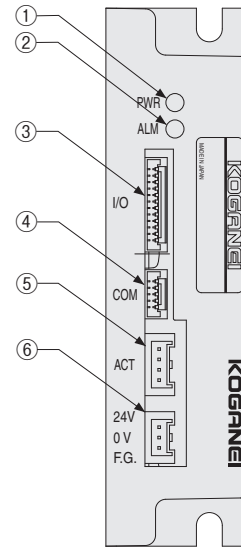

State	Power (green)	ALM (red)
Power off	Off	Off
Power on	Lighted	Slow flashing (ON: 0.5 s, OFF: 1.5 s)
Normal before origin return	Lighted	Slow flashing (ON: 0.5 s, OFF: 1.5 s)
Normal after origin return	Lighted	Off
Operating	Lighted	Off
Error	Lighted	Fast flashing (ON: 0.25 s, OFF: 2.5 s)
Alarm	Lighted	Lighted

4-2 Installation and connecting to external devices

4-2-1 Installing the controller

(1) Installation method

Attach the controller to the heat conductive material with the M4 screws using the 5 mm U-shaped notch on the back of the controller.

(2) Installation environment

- Install the controller in an environment with an ambient temperature of 0 to 40°C [32 to 104°F] and humidity of 35 to 85% that is not subject to condensation.
- Install at a well-ventilated location with sufficient space (at least 20 mm [0.79 in]) around the controller.
- Avoid installing the controller in locations where corrosive gases (e.g. sulfuric acid, hydrochloric acid) are generated, or in atmospheres that include combustible gases and inflammable liquids.
- Install in a location subject to little dust and dirt.
- Install in a location not subject to splashing with chips, oil, water, or other liquids from other equipment and devices.
- Avoid installing in locations where electromagnetic noise and electrostatic noise are generated.
- Install in a location free from extreme vibrations.

4-2-2 Connecting the power supply

(1) Power supply

- 24VDC ±10% Connect the power cable to a power supply having the current capacity shown in the table below.

Model	IBM2A5	IBM2A10	IBM2A16
Current capacity	1 A or more	1.5 A or more	2 A or more

Connector pin layout list

No.	Signal name	Lead color	Description
1	24V	Red	Power supply
2	0V	Blue	
3	F.G.	Green	Ground

[Caution]

- When the power voltage supplied to the controller is unstable, an alarm stop sometimes occurs or operation is abnormal. Accordingly, pay sufficient attention when selecting the 24V power supply. Use as stable a power supply as possible.

(2) How to connect the power supply

- Connect the power supply using the power cable (provided). When connecting the power supply, make sure that the wiring connections are correct. Incorrect connections might cause fire or other serious hazards.

[Caution]

- The IBM2A-C controller has no power switch or emergency stop switch. Be sure to install an appropriate power breaker as part of the mechanical system.

[Danger]

- Before wiring the controller, be sure to turn the power to the entire mechanical system off. Failure to do so might cause electric shock.

(3) Insulation resistance/dielectric strength testing

Never perform insulation resistance testing or dielectric strength testing on the controller.

4-2-3 Grounding

- Be sure to connect a ground to protect people from possible current leaks and prevent malfunctions caused by noise.
- Class D grounding (max. grounding resistance 100 Ω) is strongly recommended.
- Use the F.G. lead of the power cable for the ground terminal on the controller.

4-2-4 Connecting to a PC

- The USB-RS485 converter (IBM2A-H) can be connected to devices such as a PC that supports a USB interface.
- To use the support software, connect the controller to the USB port on a PC using the USB-RS485 converter.

4-2-5 Connecting to an actuator

Connect the actuator cable to the ACT connector on the front panel of the controller while the controller is off. Insert the actuator cable firmly into the connector.

4-2-6 Connecting the I/O connector

Connect the I/O connector to a programmable controller or other external device.

4-3 I/O interface

4-3-1 I/O connector signal table

No.	Lead color	Signal name	Description	No.	Lead color	Signal name	Description
01	Brown	ORG	Origin return signal	02	Red	STOP	Stop
03	Orange	GO-P0	Move to P0	04	Yellow	GO-P1	Move to P1
05	Green	READY	Ready output	06	Blue	BUSY	Executing command
07	Purple	STAY-P0	P0 move completed output	08	Gray	STAY-P1	P1 move completed output
09	White	24VI	I/O power 24V input	10	Black	24GI	I/O power - common
11	Brown	24VO	(24V internal power supply)	12	Red	24GO	(0 V internal power supply)

4-3-2 Details of input signals

Four custom command inputs are provided as input signals.

○ Custom command inputs

"Custom command inputs" are used for controlling the controller from a programmable controller or other external device. So that GO-P0, GO-P1 and ORG inputs can be accepted, the READY and BUSY signals must meet the following conditions.

- READY output: ON
- BUSY output: OFF
- STOP input: OFF

GO-P0, GO-P1 and ORG inputs are accepted when the state changes from OFF to ON (moment that contact is closed). Whether or not the controller can accept commands can be verified by monitoring BUSY output.

■ GO-P0

Move to point number P0.

■ GO-P1

Move to point number P1.

■ ORG

Origin return is executed. When PRM2 is 0, origin return is always required after the power is turned on.

PRM3 = 0 STOP input

PRM3 = 1 SW input

■ STOP

This input is for turning actuator excitation off.

The actuator can be set to a free state by turning this input ON (i.e. closing the contact) during actuator operation or origin return operation. When this input is ON (contact closed), GO-P0, GO-P1 and origin return cannot be executed using I/O.

■ SEN

Input from origin sensor.

4-3-3 Details of output signals

Four output signals READY, BUSY, STAY-P0, and STAY-P1 are provided.

"ON/OFF" refers to the ON/OFF state of the output transistor.

○ Custom output

This output is for performing signal exchanges with a programmable controller, etc.

■ Ready output (READY)

This output is ON while the controller system is running normally. However, when an alarm occurs, the output turns OFF and the motor enters the free state. However, note that this output is in an OFF state when the power is turned on.

■ Command execution output (BUSY)

This signal turns ON while custom commands are executing or while a command from the support software is executing. Since this signal turns ON when a custom command input is accepted, the controller does not accept a custom command input or a command from the support software while the BUSY signal is ON.

[Caution]

Be sure to turn a custom command off when BUSY turns ON. When inputs stay ON, BUSY cannot be turned OFF even if the command execution is completed.

■ P0 output (STAY-P0)

This output turns ON after P0 move is completed, and turns OFF during P0 movement or at P1 movement completed.

■ P1 output (STAY-P1)

This output turns ON after P1 move is completed, and turns OFF during P1 movement or at P0 movement completed.

4-3-4 I/O circuit

This section describes the specifications of the I/O circuit and provides connection examples. Refer to this section when connecting to a programmable controller or other external device.

(1) I/O circuit specifications

○ Input power supply

Input voltage: 24VDC \pm 10%

○ Input circuit

Insulation method: Photo coupler insulation

Input response: 30 ms or less

Input current: 5 mA/24VDC

Input sensitivity: ON current, 3 mA or more

OFF current, 0.5 mA or less

○ Output circuit

Insulation method: Photo coupler insulation between internal circuit and output transistor

Output terminal: NPN open collector output of common terminal for all output

Output response: 1 ms or less

Max. output current: 30 mA/24VDC per output

Residual ON voltage: 0.5V or less

(2) Connector wiring diagram

① If origin sensor is not used

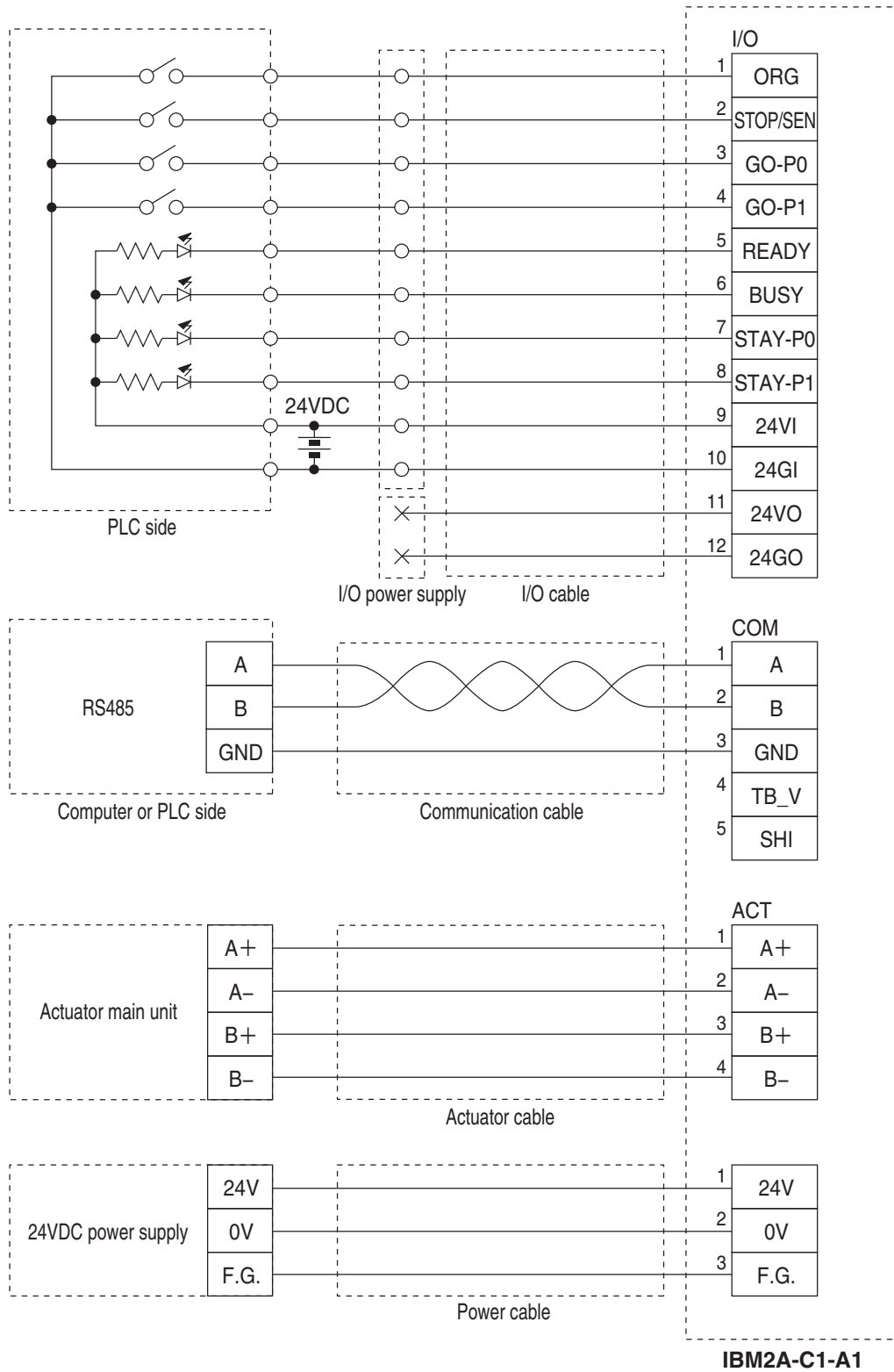

② If origin sensor is used (recommended)

Procedure to connect the sensor's origin output and power source to the controller. Return to origin will be smooth.

The wiring is simple, but the output of the origin cannot be sent to the PLC.

Use the mini clamp wire mount plugs for the connections.

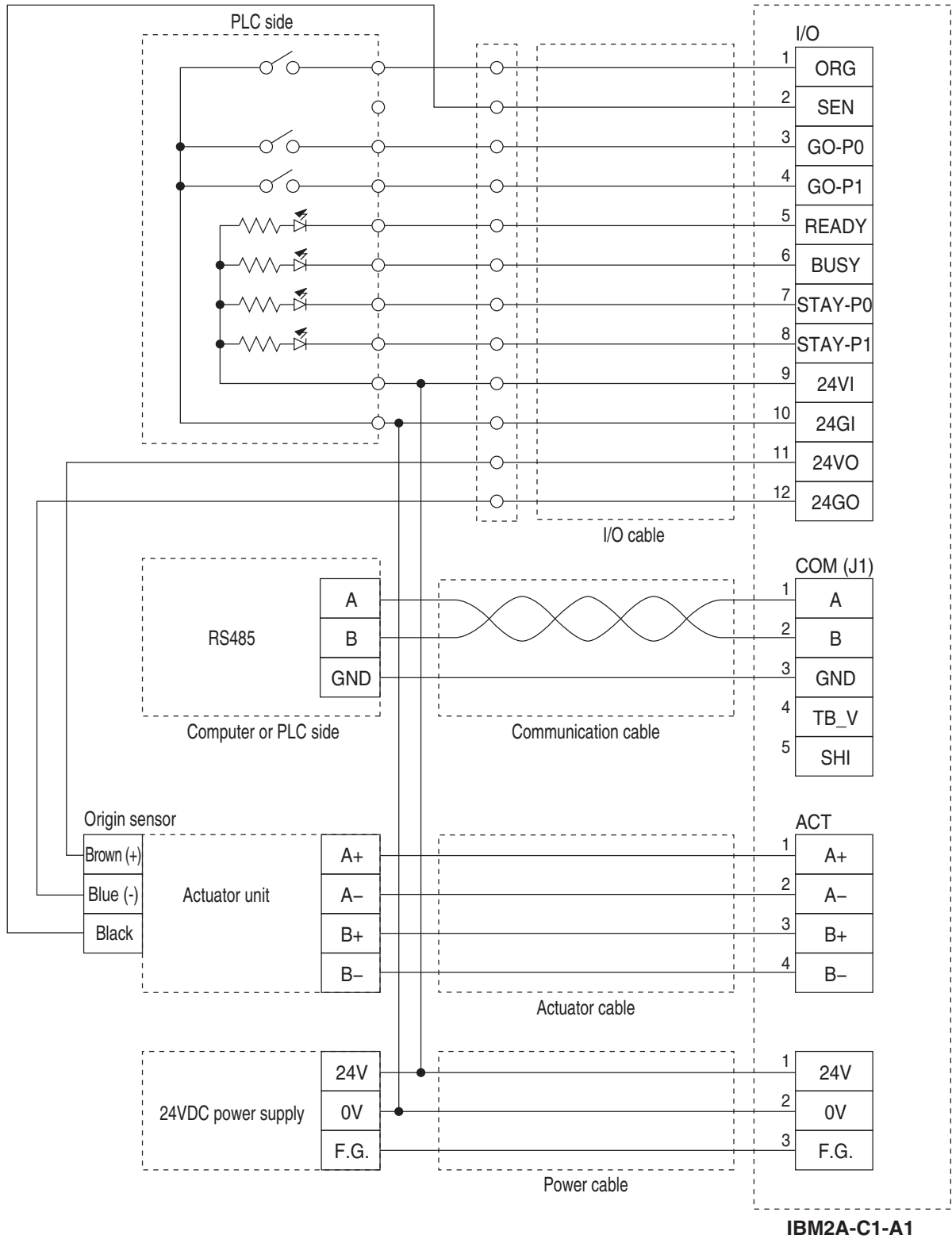

③ If origin sensor is used (reference)

Procedure to connect the sensor's origin output and power source directly to the customer's PLC. Return to origin will be smooth.

The wiring is complicated, but the output of the origin can be sent to the PLC.

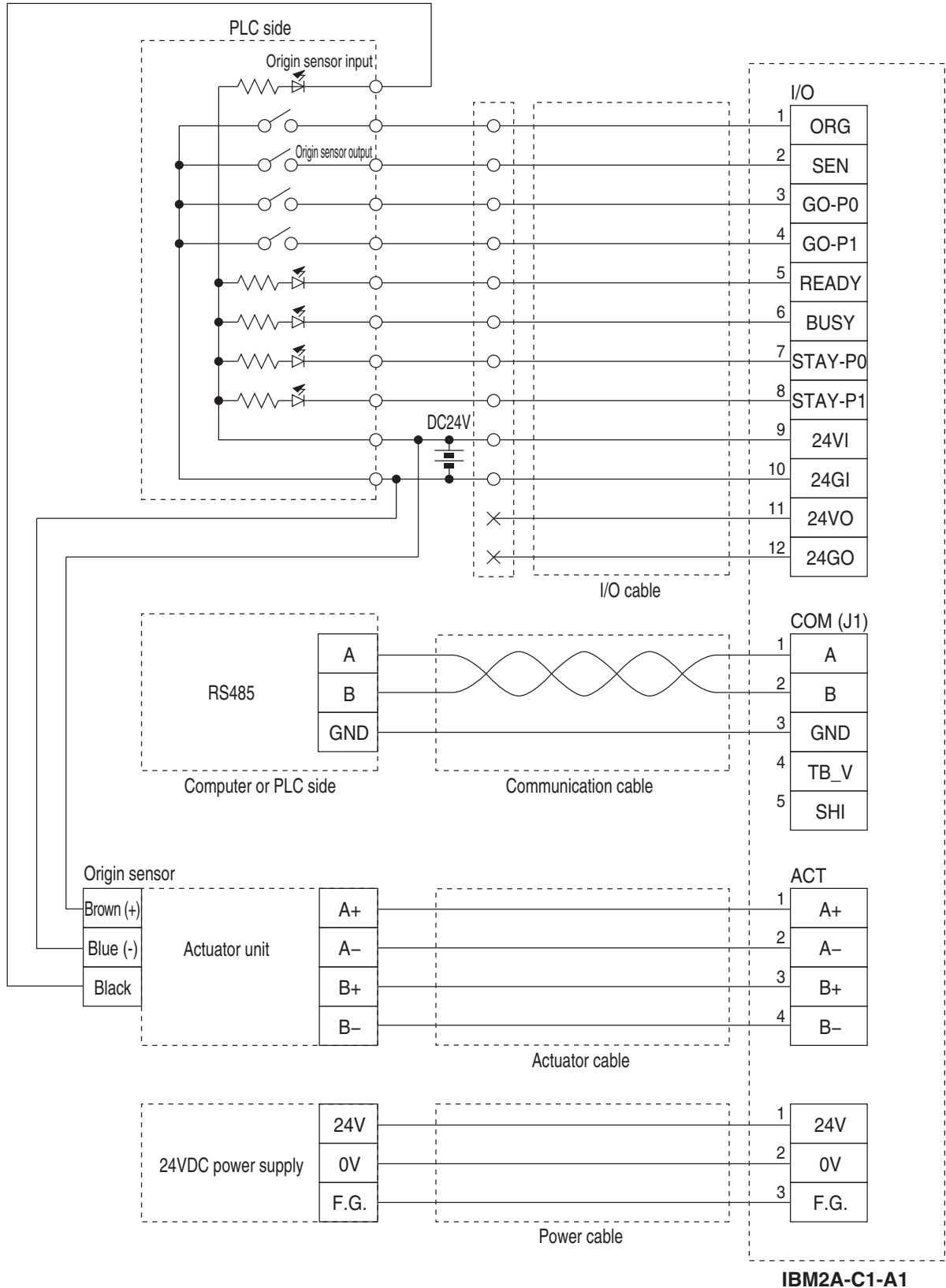

IBM2A-C1-A1

4-3-5 Timing charts

(1) Power on

- When the power is turned on, the READY, BUSY, STAY-P0, and STAY-P1 outputs are OFF.
- Allow at least 500 ms until ORG input after the power is turned on.

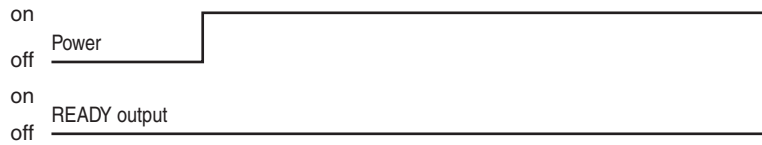

(2) Origin return by ORG input

- When ORG input is accepted, the READY and BUSY outputs turn ON. Whether or not the accepted command ended normally is judged by whether or not the BUSY output turned OFF.
- Be sure to set pulsed input for the ORG input. When inputs stay ON, BUSY does not turn OFF even if origin return is completed.

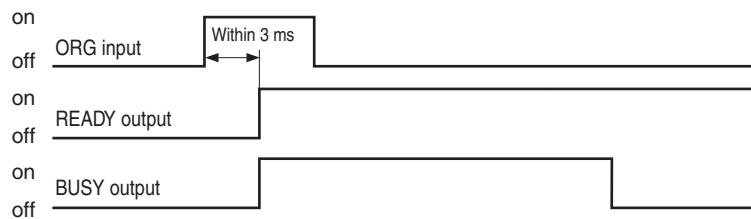

- ① READY and BUSY turn ON at the start-up of ORG input.
- ② ORG input is turned OFF (i.e. contact is opened) after confirmation that BUSY turned ON.
- ③ BUSY turns OFF after completion of origin return.

(3) Execution of GO-P0 and GO-P1 inputs

- The BUSY output turns ON when the GO-P0 or GO-P1 input is accepted. Whether or not the accepted command ended normally is judged by whether or not the BUSY output turned OFF.
- Be sure to set pulsed input for the GO-P0 and GO-P1 inputs. When input stays ON, BUSY does not turn OFF even if movement is completed.

1. D mode (P0⇒P1 movement)

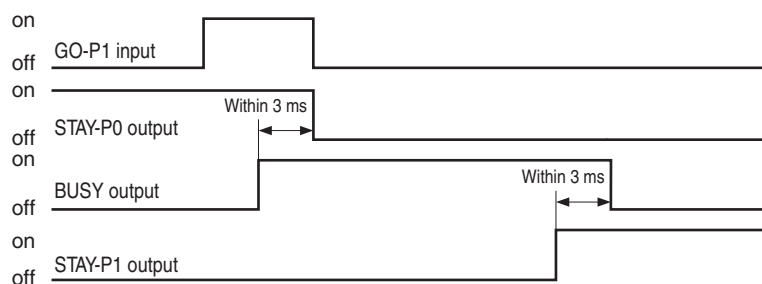

- ① BUSY turns ON at the start-up of GO-P1 input.
- ② GO-P1 input is turned OFF (i.e. contact is opened) after confirmation that BUSY turned ON.
- ③ The controller waits for BUSY to turn OFF.
- ④ When BUSY turns OFF, STAY-P1 is ON, which means normal completion.

2. H mode (P1⇒P0 movement)

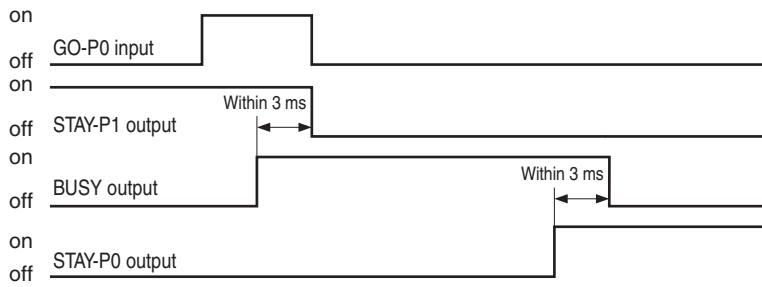

- ① BUSY turns ON at the start-up of GO-P0 input.
- ② GO-P0 input is turned OFF (i.e. contact is opened) after confirmation that BUSY turned ON.
- ③ The controller waits for BUSY to turn OFF.
- ④ When BUSY turns OFF, STAY-P0 is ON, which means normal completion.

(4) When STOP is input (P0⇒P1 movement)

- BUSY and READY turn OFF when STOP is input during command execution.
- ORG input is not accepted while STOP input is ON. Be sure to turn STOP input OFF, and execute origin return by ORG input, and then perform GO-P0 or GO-P1 operations after origin return is completed.

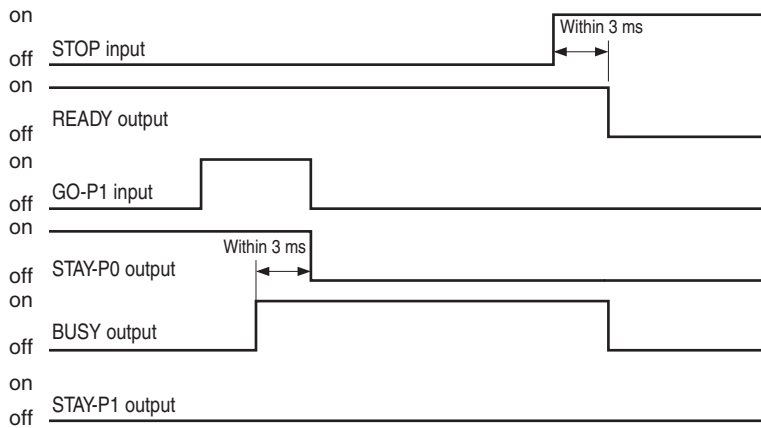

(5) When an error (P0⇒P1 movement) occurs

- When an error occurs during execution of a command, BUSY and READY are ON, which means that the accepted command will end normally.

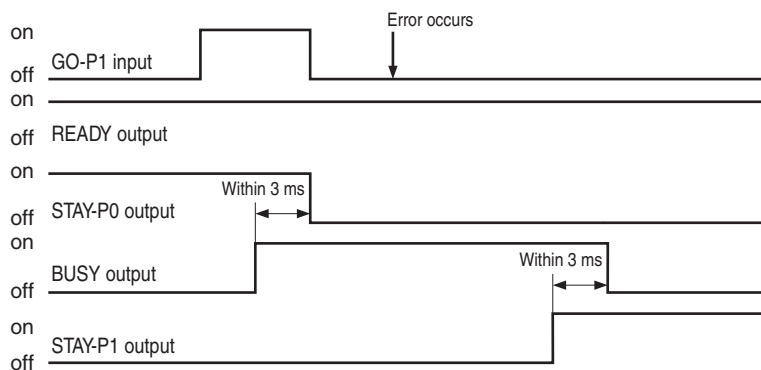

(6) When an alarm (P0⇒P1 movement) occurs

- BUSY and READY turn OFF when an alarm occurs during command execution.
- To cancel an alarm, turn the power off then back on again, and execute origin return by ORG input, and then perform GO-P0 or GO-P1 operation after origin return is completed.

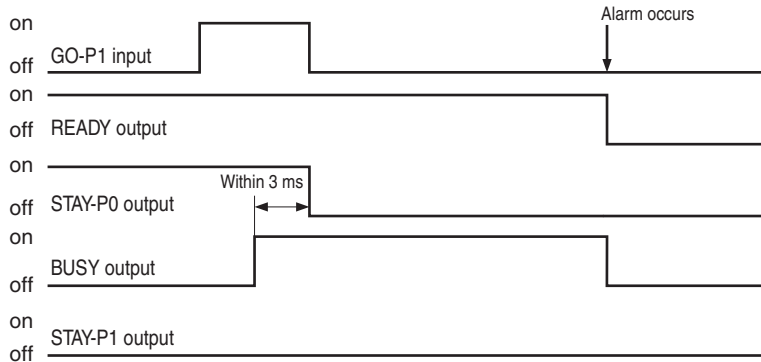

4-4 Setting the actuator number

Set the actuator number in the following table to match the actuator model.

Model	Actuator number
IBM2A 5x10	100
IBM2A 5x20	101
IBM2A10x20	110
IBM2A10x30	111
IBM2A16x32	120
IBM2A16x48	121

Actuator number setting method (Set by either of the following methods.)

1. In the initialization (INT) mode, initialize the parameters and points using the teaching box.
(For details, refer to the instruction manual for the teaching box.)
2. Initialize the parameters and points in the initialization settings using the support software.
(For details, refer to the instruction manual for the support software.)

Note 1: When the actuator and controller are bought together as a set, the controller is shipped with the actuator number of the purchased actuator already set to the specified number

Actuator number setting value at initialization of points

Actuator number	100		101		110		111		120		121	
	P0	P1	P0	P1	P0	P1	P0	P1	P0	P1	P0	P1
Mode	D	D	D	D	D	D	D	D	D	D	D	D
Position	0	10	0	20	0	20	0	30	0	32	0	48
Speed %	30	30	30	30	30	30	30	30	30	30	30	30
Acceleration %	30	30	30	30	30	30	30	30	30	30	30	30
Deceleration %	30	30	30	30	30	30	30	30	30	30	30	30

4-5 Point data specifications

P0=Mode, position (mm), speed (%), acceleration (%), deceleration (%), pressing force level (set in 10 stages, 1 to 10)
 (Input not required when D mode is specified)

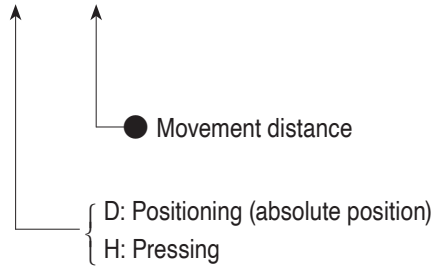

● iB-Move operation mode

Operation mode	D mode operation (move to P1)	H mode operation (move to P1)								
Operation pattern										
Description	<ul style="list-style-type: none"> In D mode, set point P1 data and operate, and it moves to the point specified as P1 at the specified speed, acceleration and deceleration, and then stops. 	<ul style="list-style-type: none"> In H mode, set point P1 data and operate, and it moves to the point specified as P1 at the specified speed, acceleration and deceleration, and then sends the deviation pulse in order to generate pressing force and stops. <p>Note 1: If there is no stopper or workpiece at the specified point, the movement amount will overrun in accordance with the deviation pulse. The overrun amount is as shown below. During this operation, the current command value becomes the P1 specified position.</p> <table border="1"> <thead> <tr> <th>Model</th> <th>Overrun amount</th> </tr> </thead> <tbody> <tr> <td>IBM2A 5x□</td> <td>5 mm</td> </tr> <tr> <td>IBM2A10x□</td> <td>5 mm</td> </tr> <tr> <td>IBM2A16x□</td> <td>8 mm</td> </tr> </tbody> </table> <p>2: After movement, additional movement in the same direction is not possible.</p>	Model	Overrun amount	IBM2A 5x□	5 mm	IBM2A10x□	5 mm	IBM2A16x□	8 mm
Model	Overrun amount									
IBM2A 5x□	5 mm									
IBM2A10x□	5 mm									
IBM2A16x□	8 mm									

4-6 Parameters

This controller has no hardware adjustment mechanisms, such as potentiometers and DIP switches.

Parameters that can be easily set using the teaching box or the support software are used instead.

This section describes how to change and set parameters, and gives a detailed description of each parameter.

Safety

Before the actuator and controller are shipped from the factory as a set, the controller is initialized to match the actuator model. Otherwise, the actuator number must be set to match the actuator model before you can start to use the controller. (See P. 14.) If any trouble occurs, contact Koganei.

[Caution]

Inadvertently changing the parameters listed in this instruction manual may cause critical trouble on the actuator and controller.

4-6-1 How to set parameters

Edit parameters using the teaching box or the support software.

For details on handling the support software, refer to the separate instruction manual for the support software.

For details on handling the teaching box, refer to the separate instruction manual for the teaching box.

4-6-2 Description of parameters

PRM0: Actuator number

Displays the actuator number. This parameter is read-only.

PRM1: English/Japanese switching

This parameter sets the language of messages in communications.

Input range 0, 1

Meaning 0: English, 1: Japanese

Default 1

PRM2: Origin return method setting

This parameter sets whether to perform origin return by ORG input after the power is turned on or perform origin return automatically when the power is turned on.

Input range 0, 1

Meaning 0: ORG input, 1: Automatic

Default 0

PRM3: STOP/sensor switch setting

This parameter sets the input signal of the number 2 I/O.

Input range 0, 1

Meaning 0: STOP, 1: Origin sensor

Default 0

PRM5: Origin return position

This parameter sets the position after origin return is performed.

Input range 0, 1, 2

Meaning 0: Retracted side, 1: P0, 2: P1

Default 0

PRM6: Origin shift value

This parameter sets the virtual origin. Always to return to origin after the settings. When a return to origin is done, first the unit returns to the mechanical origin, next it moves the value set for the origin shift to finish the return to origin. And, that position is 0.

Input range -480 to 480 (x0.1 mm)

Default 0

Actuator number	100	101	110	111	120	121
Default	0	0	0	0	0	0
Input range (x0.1 mm)	-50 to 50	-100 to 100	-100 to 100	-150 to 150	-160 to 160	-240 to 240

PRM21: Teaching movement unit

This parameter sets the movement unit during teaching playback of points.

Actuator number	100	101	110	111	120	121
Default	10	10	10	10	10	10
Input range (x0.1 mm)	1 to 100	1 to 100	1 to 100	1 to 100	1 to 100	1 to 100

PRM30: Maximum speed

This parameter sets the maximum speed during operation.

Actuator number	100	101	110	111	120	121
Default	300	400	500	600	600	700
Input range (mm/s)	1 to 300	1 to 400	1 to 500	1 to 600	1 to 600	1 to 700

PRM31: Max. acceleration/deceleration

This parameter sets the maximum acceleration/deceleration during operation.

Actuator number	100	101	110	111	120	121
Default	10000	10000	20000	20000	20000	20000
Input range (mm/s ²)	1 to 20000	1 to 20000	1 to 20000	1 to 20000	1 to 20000	1 to 20000

PRM32: Origin return speed

This parameter sets the speed during origin return.

Actuator number	100	101	110	111	120	121
Default	10	10	10	10	10	10
Input range (mm/s)	1 to 100	1 to 100	1 to 100	1 to 100	1 to 100	1 to 100

PRM33: Origin shift speed

Sets the speed during origin shift.

Input range 1 to 100 (mm/s)

Default 10

PRM34: Teaching movement speed

This parameter sets the movement speed during teaching playback of points.

Actuator number	100	101	110	111	120	121
Default	10	10	10	10	10	10
Input range (mm/s)	1 to 100	1 to 100	1 to 100	1 to 100	1 to 100	1 to 100

PRM37: H mode switching speed

This parameter sets the speed for switching to pushing (press) operation in the H mode.

Actuator number	100	101	110	111	120	121
Default	50	50	50	50	50	50
Input range (mm/s)	1 to 300	1 to 400	1 to 500	1 to 600	1 to 600	1 to 700

PRM38: H mode pushing (press) speed

This parameter sets the feed speed of the deviation pulse for performing pushing (press) operation in the H mode.

Actuator number	100	101	110	111	120	121
Default	300	300	300	300	300	300
Input range (mm/s)	1 to 300	1 to 300	1 to 300	1 to 300	1 to 300	1 to 300

PRM39: H mode pushing (press) return speed

This parameter sets the return speed of the deviation pulse for returning pushing (press) operation in the H mode.

Actuator number	100	101	110	111	120	121
Default	300	300	300	300	300	300
Input range (mm/s)	1 to 300	1 to 300	1 to 300	1 to 300	1 to 300	1 to 300

PRM44: Electric current ratio at stop (Only in D mode)

This parameter sets the ratio of the current at a stop with respect to the rated current.

Actuator number	100	101	110	111	120	121
Default	60	60	60	60	60	60
Input range (%)	1 to 100	1 to 100	1 to 100	1 to 100	1 to 100	1 to 100

4-7 List of messages

4-7-1 Error messages

(1) Command related

Error number	Item	Description
21	Message	Erroneous input
	Cause	Wrong command
	Remedy	Input the command correctly
23	Message	Data error
	Cause	Numerical value is wrong
	Remedy	Correct the data.

(2) Operation related

Error number	Item	Description
31	Message	Running
	Cause	Commands are not accepted while a command is already executing
	Remedy	Wait until the currently executing command ends before inputting the command
32	Message	Origin return not complete
	Cause	Commands cannot be executed since origin return is not completed
	Remedy	Perform origin return.
35	Message	Cannot execute
	Cause	Parameters contradict operation commands
	Remedy	Change the point data or parameter
37	Message	Limit over
	Cause	The position to which movement is attempted exceeds the software limits
	Remedy	Correct the point data
38	Message	No origin
	Cause	Cannot complete return to origin
	Remedy	Check for damage and then do return to origin again

(3) System related

Error number	Item	Description
58	Message	Data save in progress
	Cause	An attempt was made to write data before a data write was completed
	Remedy	Create an interval in communications.

(4) Stop message

Error number	Item	Description
61	Message	Stop command
	Meaning	A stop was executed because of a stop command

5 Troubleshooting

5-1 When an abnormality occurs

When contacting Koganei about the circumstances in which an abnormality occurred, try to provide as much detail for each of the following items.

Item	Description (Examples)
What?	Controller model Actuator model Power supply
When?	The time of purchase (manufacturing number) Operating period and circumstances After power on, or 1 hour after power on etc.
In what state?	During operation When iB-Move arrived at specified location
Result of operation	No operation Alarm occurred
Frequency	Always occurs Once every hour Has not reoccurred

5-2 Action and remedy when an alarm occurs

An alarm is judged as occurring when READY output is OFF. The ALM LED on the controller front panel also lights when an alarm occurs.

When an alarm occurs, turn the power off, remove the cause of the alarm and turn the power on again.

5-3 Alarm specifications

Alarm messages are sent in the following format.

```
<Alarm number>: <Alarm message> c/r l/f
```

5-3-1 Alarm message list

Alarm number	Alarm message	Meaning	Probable Cause	Remedy
03	Overheat	Circuit temperature is rising	1) Overcurrent 2) Cable short-circuit	Check the cable
04	Power supply voltage drop	Input voltage is too low	Power supply	Raise the power supply voltage
05	Power supply voltage over	Input voltage is too high	Power supply	Lower the power supply voltage
08	Defective point data	Point data is corrupted	The power was turned off while writing data	Turn the power off then back on, and initialize the point data
09	Defective parameter data	Parameter data is corrupted	The power was turned off while writing data	Turn the power off then back on, and initialize the parameters

6 Specifications

6-1 Main unit basic specifications

Item	Model	IBM2A5		IBM2A10		IBM2A16	
Motor		2-phase stepping, moving magnet system					
Stroke	mm [in]	10 [0.394]	20 [0.787]	20 [0.787]	30 [1.181]	32 [1.260]	48 [1.890]
Maximum thrust ^{Note 1} N [lbf]	Vertical use ^{Note 2}	0.55 [0.124]		2 [0.45]		6 [1.35]	
	Horizontal use	0.7 [0.16]		2.5 [0.56]		8 [1.80]	
Maximum speed	mm/s [in/sec]	300 [11.8]	400 [15.7]	500 [19.7]	600 [23.6]	600 [23.6]	700 [27.6]
Position sensing		None					
Cable		Flexible cable ϕ 4.5 25AWG4 4-lead 1000, 3000, 5000 mm					
Mounting methods		Side mount A, B, and front mount					
Materials		Main unit: Aluminum alloy					
Mass (excluding cable)	g [oz]	60 [2.12]	70 [2.47]	160 [5.64]	180 [6.35]	500 [17.64]	550 [19.40]
Operating temperature/humidity range		0 to 40°C [32 to 104°F] 35 to 85% RH (non-condensation, non-freezing)					
Storage temperature		-10 to 65°C [14 to 149°F] (non-condensation, non-freezing)					

Note 1: The value given for thrust is at press level 10 at the pressing point and takes into account product variations.

2: Values shown for thrust during vertical use are the thrust during horizontal use minus the mass of the moving part as it rises.

The actual payload varies in accordance with customer use conditions.

In particular, confirmation of the acceleration and deceleration speeds and operating frequency in the case of vertical use, and drive system friction in the case of horizontal use on the actual machine is recommended.

6-2 Controller basic specifications

Item	Model	IBM2A-C1-A1
Axis control	Motor drive system	Microstep drive
	Control system	Open loop control
	Operation system	PTP, force control
	Origin sensing method	Excitation phase
	Minimum setting distance mm [in]	0.1 [0.004]
	Speed setting %	1 to 100 (Minimum speed: 1mm/s)
	Acceleration, deceleration setting %	1 to 100
	Point setting Points	2
	Point input method	Value input, teaching input
External input/output	Control input	4 inputs (ORG, STOP/SEN, GO-P0, GO-P1) Photo coupler receptacle 5 mA TYP/1 input
	Control output	4 outputs (READY, BUSY, STAY-P0, STAY-P1) 30 mA [MAX] TYPE/1 output
	Abnormality detection output	Data abnormality, system abnormality
	External communication	RS485 (computer communication)
	Motor drive output	Specified cable
	Encoder input	None
General specifications	Power	24VDC (IBM2A5: 1 A min., IBM2A10: 1.5 A min., IBM2A16: 2 A min.)
	Materials	Case: Plastic
	Mass kg [oz.]	0.1 [3.53]
	Operating temperature/humidity range	0 to 40°C [32 to 104°F] 35 to 85% RH (non-condensation, non-freezing)
	Storage temperature range	-10 to 65°C [14 to 149°F] (non-condensation, non-freezing)
	Protective structure	None
	Noise resistance	IEC61000-4-4 Level 2
	Backup	EEPROM backup of setting conditions

Accessories: I/O cable, power cable

Note: STOP/SEN switched at PRM3.

6-3 Teaching box basic specifications

Item	Model	IBM2A-S1C	IBM2A-S2C
Compatible actuators		· IBM2A5 x 20 · IBM2A10 x 20 · IBM2A16 x 32	· IBM2A5 x 10 · IBM2A10 x 30 · IBM2A16 x 48
Wiring method		3-lead wire	
Power supply voltage		5 to 24VDC	
Load voltage		24V	
Load current		15 mA max.	
Consumption current		15 mA max. (at 24VDC)	
Leakage current		1 μ A max.	
Response time		5 μ s max.	
Insulation resistance		100 M Ω min. (at 500VDC megger, case and lead wires terminal-terminal)	
Withstand voltage		500VAC (50/60 Hz) 1 minute (case and lead wires terminal-terminal)	
Shock resistance ^{Note}		294.2 m/s ² (no repeating)	
Vibration resistance ^{Note}		88.3 m/s ² (double amplitude 1.5 mm · 10 to 55 Hz)	
Operation indicators		Red LED indicator lights when ON	
Wires		Heat resistant PVC 3 wires x 5000 mm (cable is black)	Heat resistant PVC 3 wires x 5000 mm (cable is gray)
Operating temperature		-20 to 80°C[-4 to 176°F]	
Storage temperature range		-40 to 80°C[-40 to 176°F]	
Mass		55 g	

Note: According to Koganei test standards.

Diagram of inner circuits

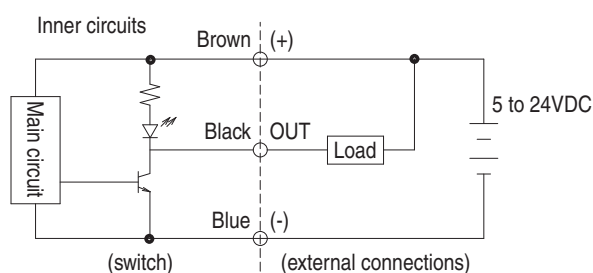

7 Dimensions

7-1 Main unit dimensions

IBM2A5 x Stroke

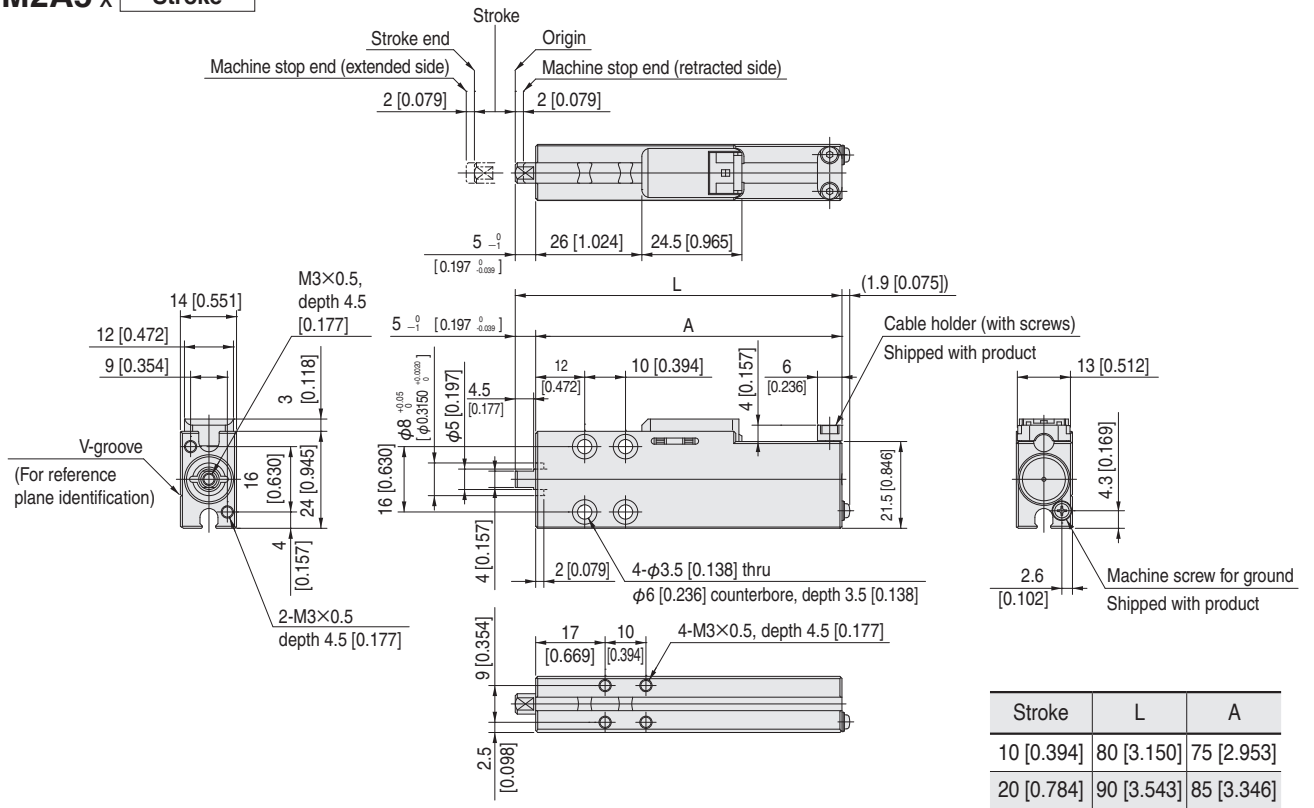

IBM2A10 x Stroke

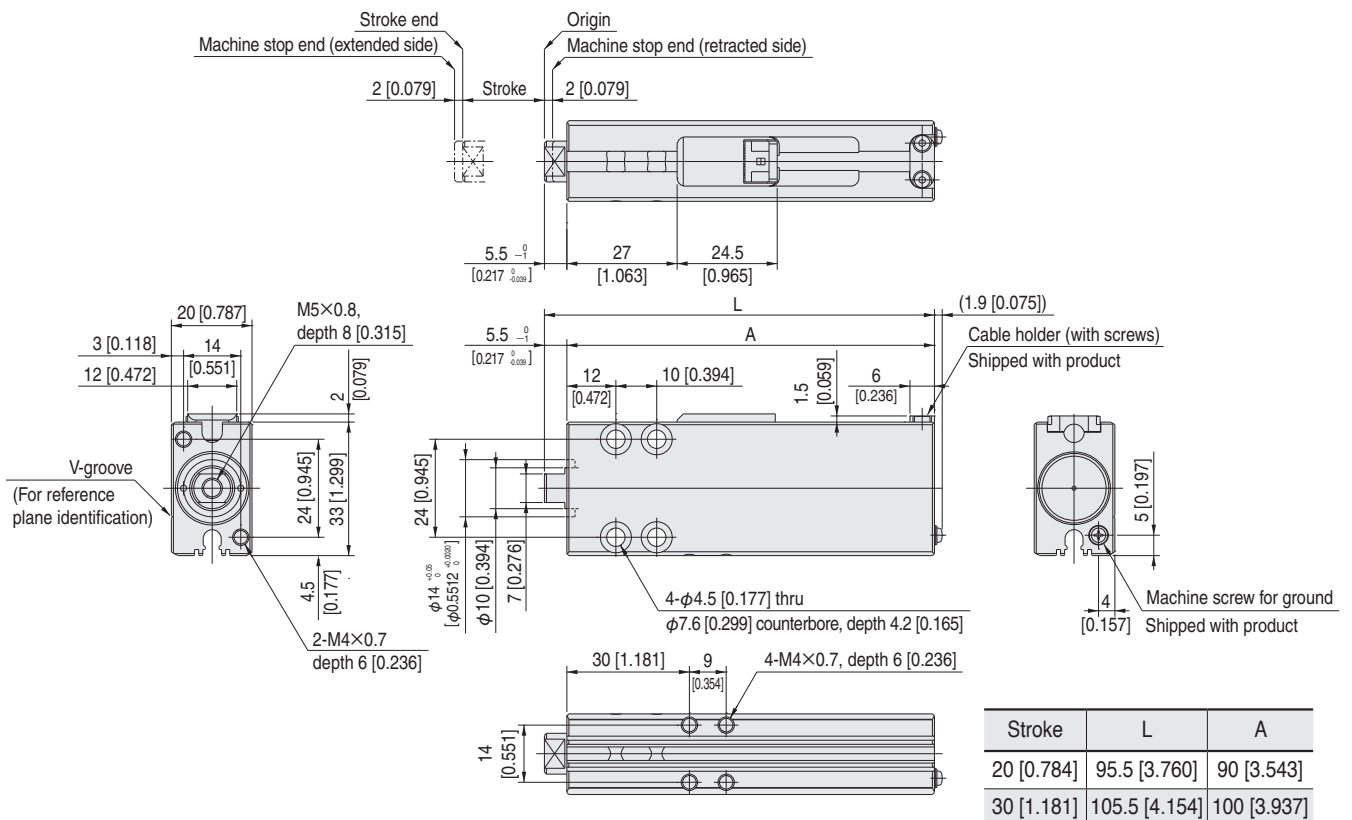

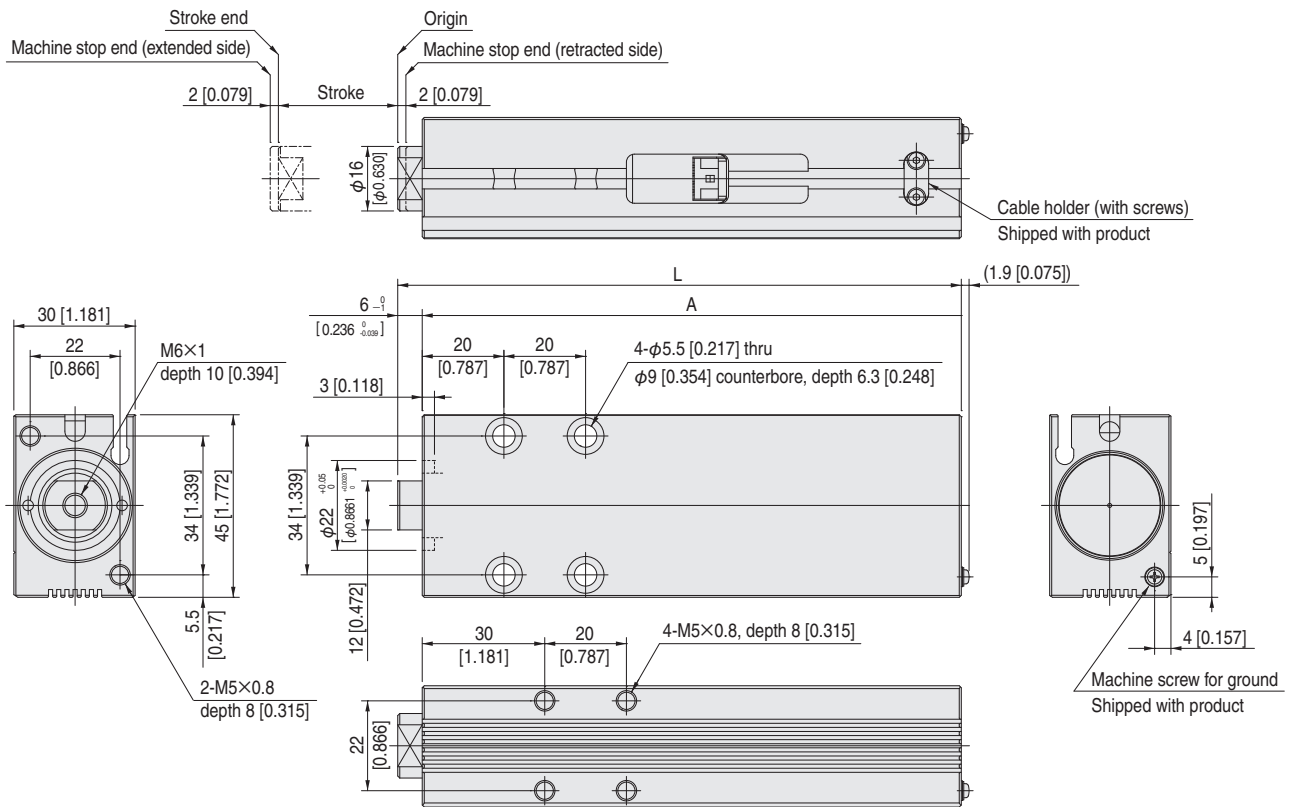
IBM2A16 x Stroke

Stroke	L	A
32 [1.260]	138 [5.433]	132 [5.197]
48 [1.890]	154 [6.063]	148 [5.827]

IBM2A5 x - - - **S1C**
S2C

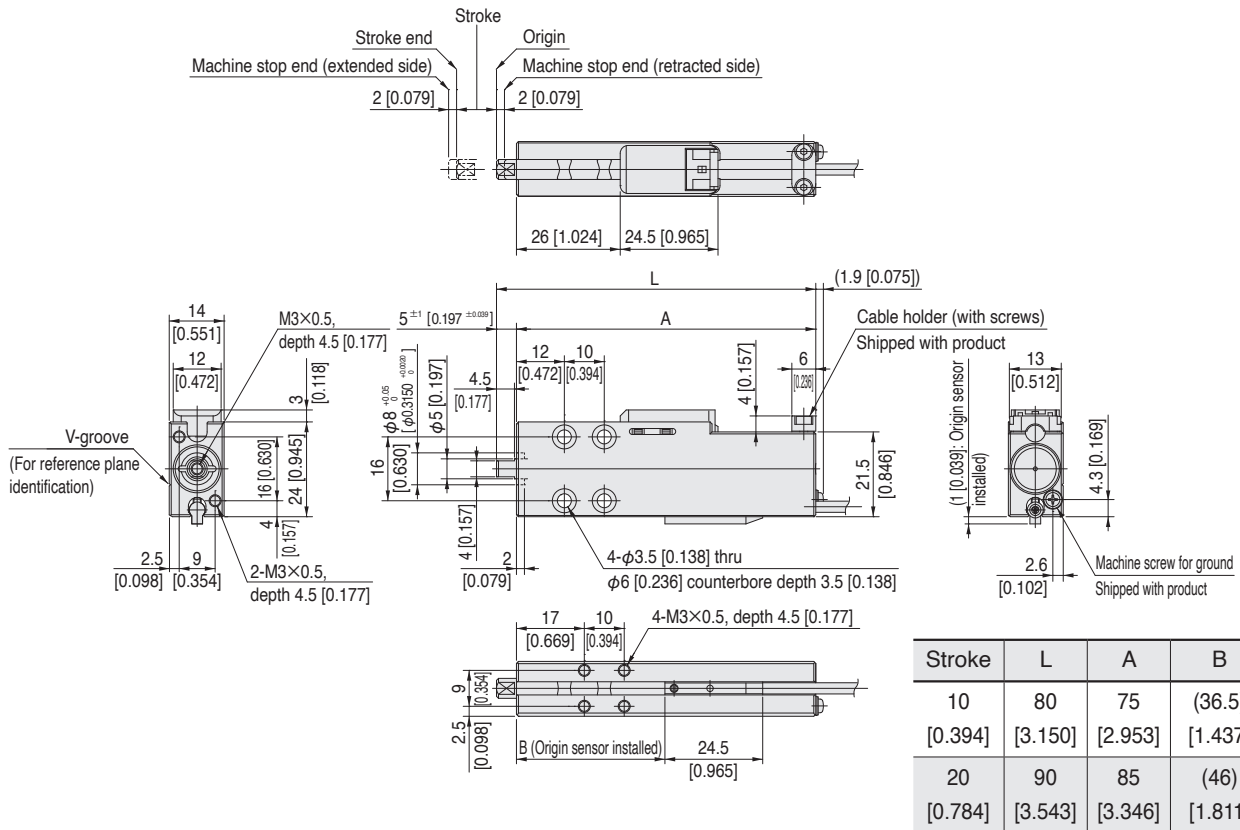

IBM2A10 x - - - **S1C**
S2C

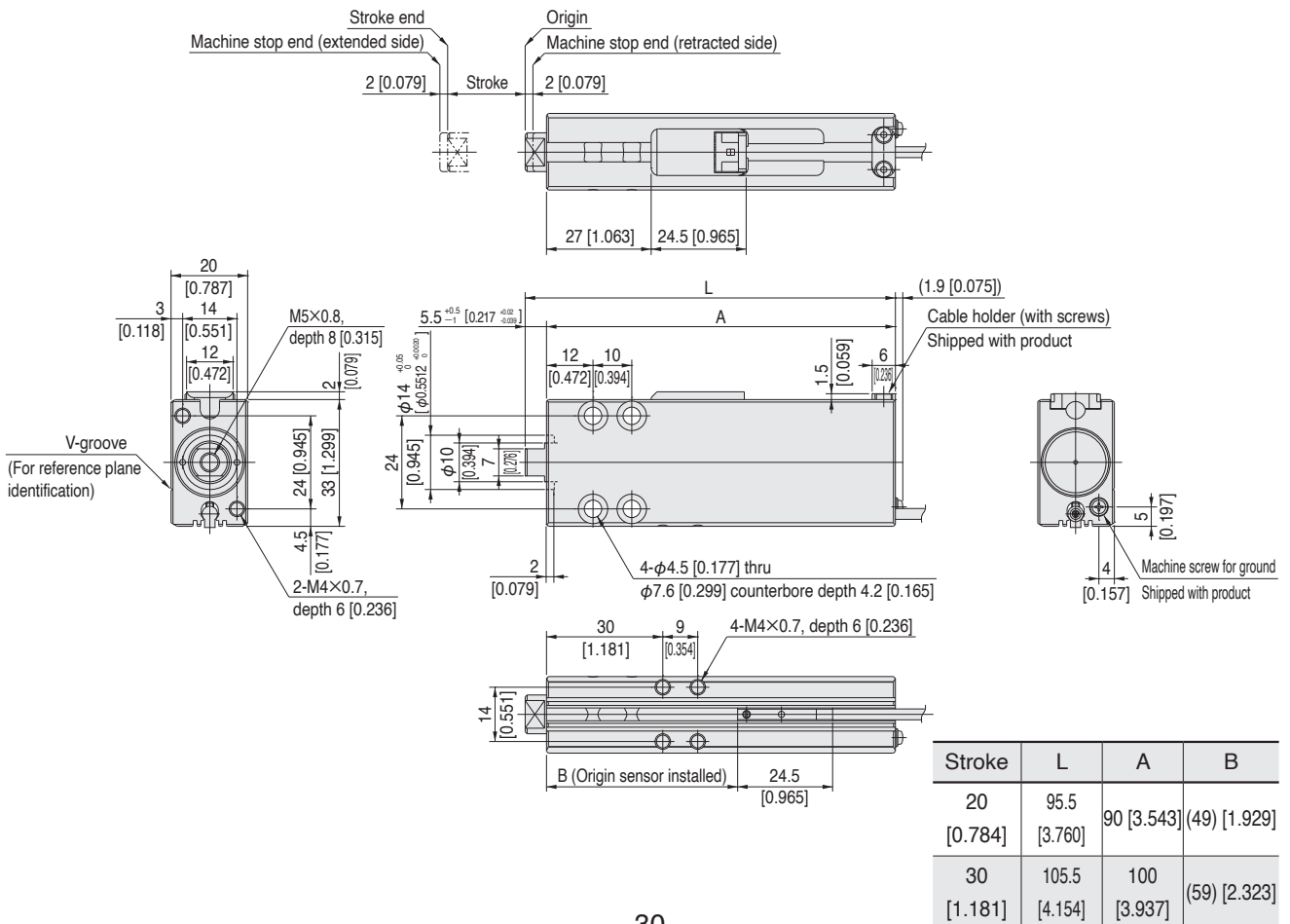

IBM2A16 x **Stroke** - - - **S1C**
S2C

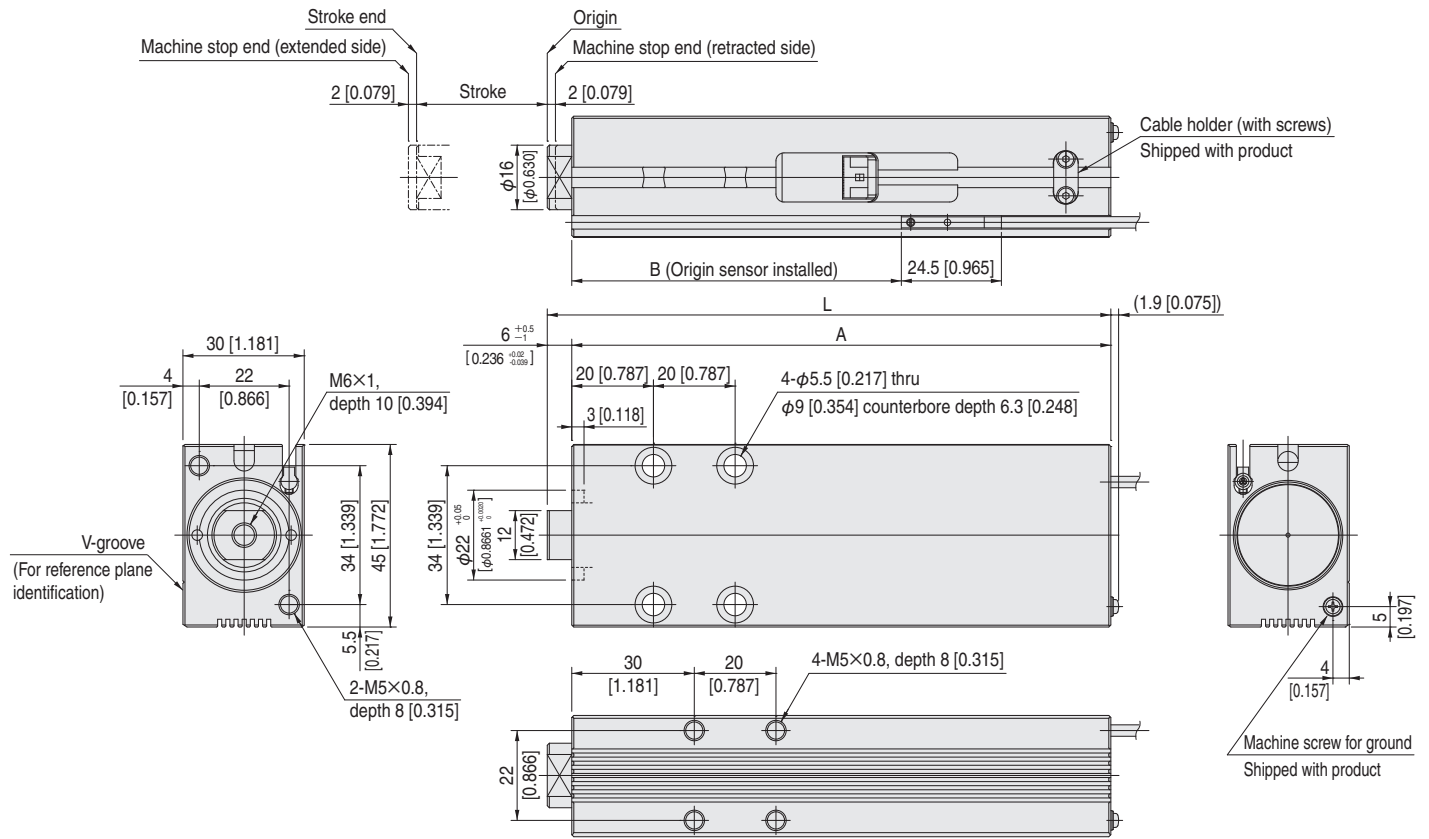

Stroke	L	A	B
32 [1.260]	138 [5.433]	132 [5.197]	(81.5) [3.209]
48 [1.890]	154 [6.063]	148 [5.827]	(97.5) [3.839]

7-2 Controller dimensions

IBM2A-C1-A1

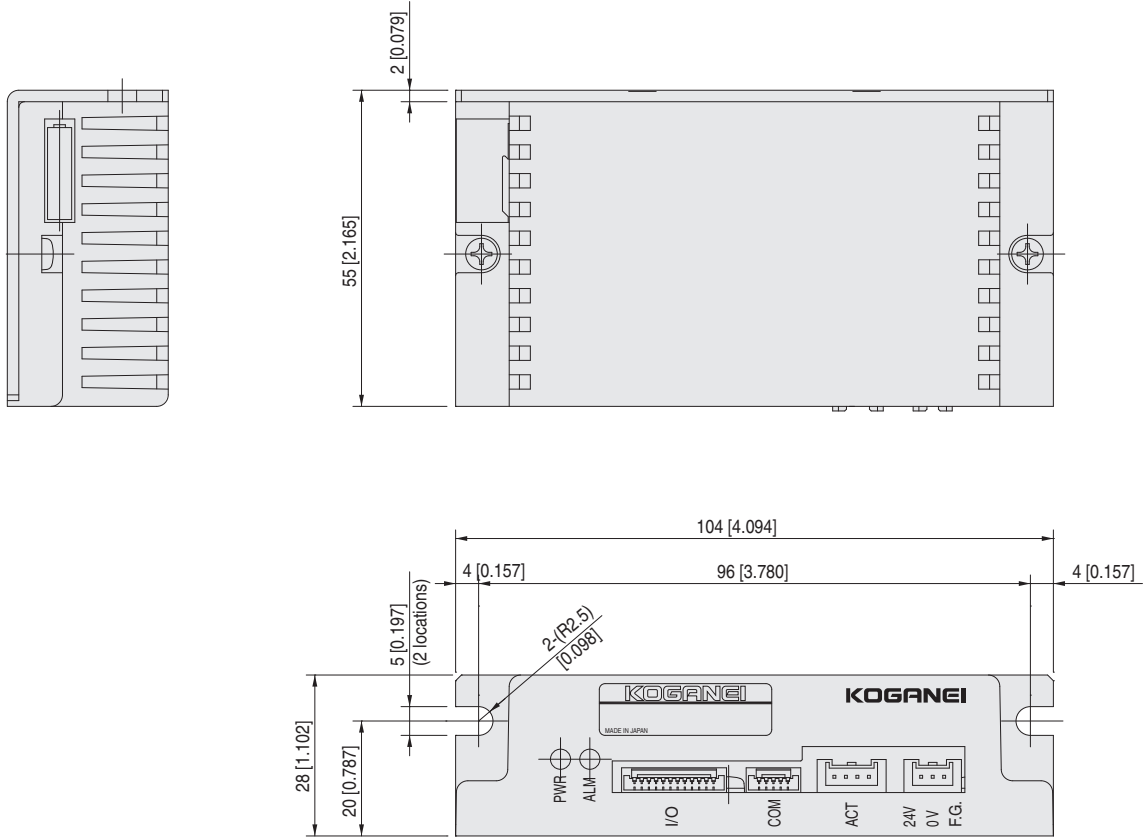

Supplied with controller

- I/O cable

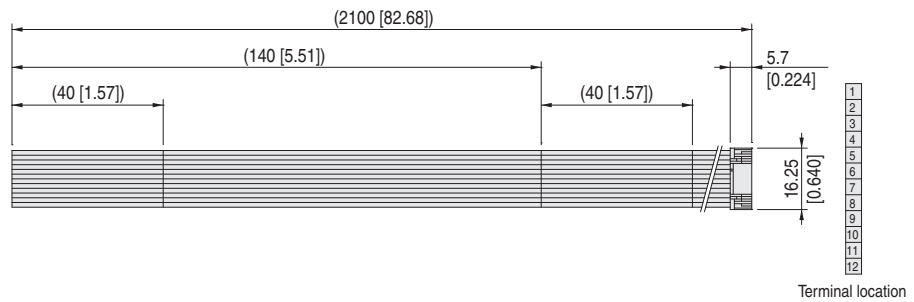

- Power cable

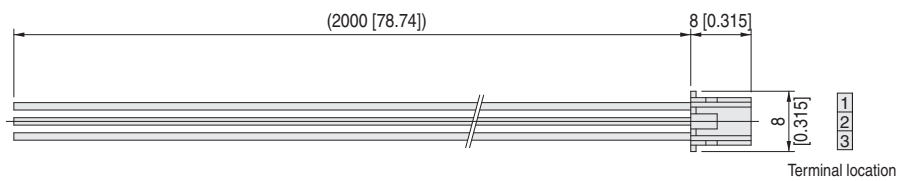

Cable (Additional parts)

• Actuator cable

IBM2A-K1-

Cable length
1L: 1000 mm [3.28 ft]
3L: 3000 mm [9.84 ft]
5L: 5000 mm [16.40 ft]

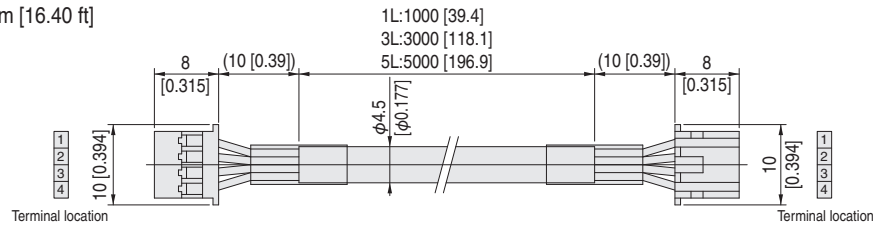

• USB-RS485 converter

IBM2A-H1-

Included cable
 Blank: USB (min-B) male ↔ USB (A) male
N : Cable not included

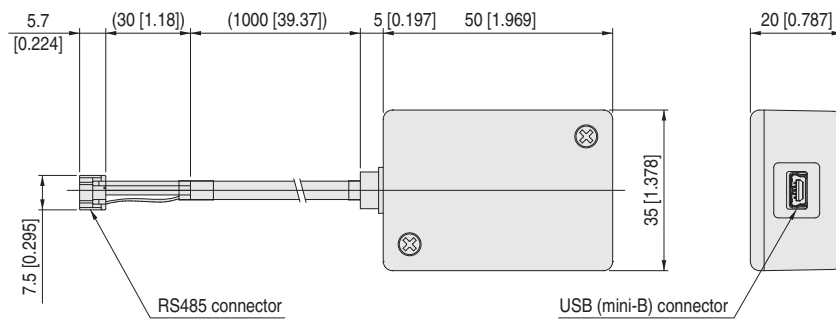

• USB cable

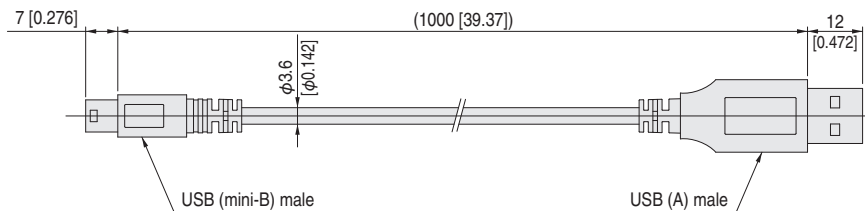

• Origin sensor

IBM2A-S **C**

Compatible models
 1 : **IBM2A5 × 20,**
 IBM2A10 × 20,
 IBM2A16 × 48
 2 : **IBM2A5 × 10,**
 IBM2A10 × 30,
 IBM2A16 × 48

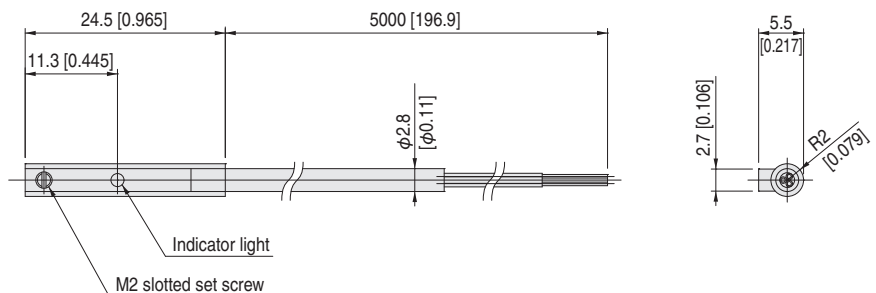

8 Technical data

8-1 Thrust

Note 1: These graphs show thrust and levels at an ambient temperature of 25°C [77°F].

Note 2: Thrust changes within the graph range in accordance with the pressing point.

IBM2A5

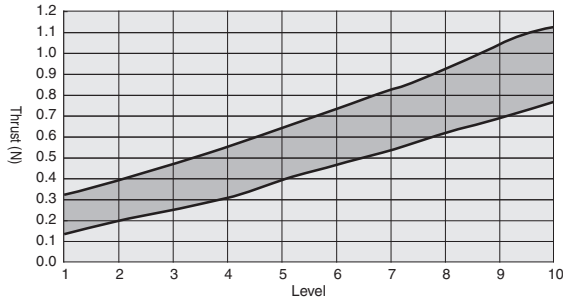

IBM2A10

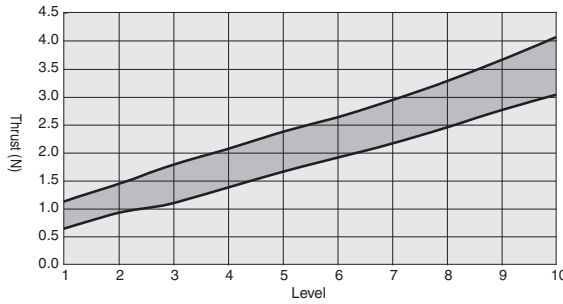

IBM2A16

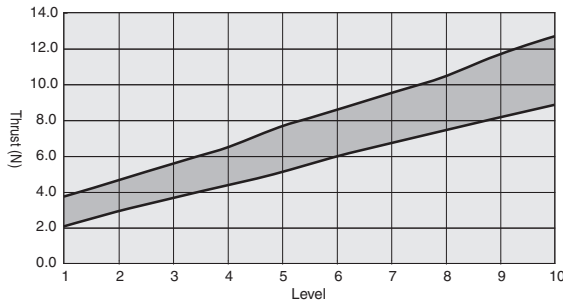

Revision History

Ver 1.1

Page 17, the input ranges of actuator numbers 100 and 101 for parameter PRM31 were changed from 1 to 10000 to 1 to 20000.

Ver 1.2

Page 23, in main unit dimensions drawing for IBM2A5, rod end screw depth changed from 6 to 4.5.

Ver 1.3

Page 6, in the table Mounting a workpiece on the rod end, for IBM2A5, rod end screw depth changed from 6 to 4.5.

Page 26, in USB cable dimensions, overall length changed from 1000 to 900.

Ver 1.4

Added origin sensor

Ver 1.5

Page 7 3. Changed the section describing installation of the origin sensor on IBM2A5 and IBM2A10 to apply only to IBM2A5.

Page 9 4. Modified the distance from the rod-side body end face to the tip of the origin sensor.

Page 26 6-2 Controller Basic Specifications: Added "Minimum speed setting: 1 mm/s."

Page 30 IBM2A5, IBM2A10 Outline drawing B dimension revised.

Page 31 IBM2A/6 Outline drawing B dimension revised.

Page 33 Origin sensor indicator lamp position revised.

If parts of this document are unclear or you have technical questions, contact the following:

<<Inquiries>>

Koganei Corporation, Overseas Group

Takanawa Office, 3F, PMO Takanawa Gateway, 2-19-17, Takanawa, Minato-Ku, Tokyo, 108-0074, Japan

TEL : +81-3-6721-7478 FAX : +81-3-5424-1021

iB-Move Main unit/Controller IBM2A-C

Instruction Manual

October, 2025 Ver. 1.5 X425103

©Koganei Corporation

Duplication or transfer of the content of this document in part or
in whole is forbidden.

URL: <https://www.koganei.co.jp>

E-mail: overseas@koganei.co.jp



KOGANEI CORPORATION

OVERSEAS GROUP

Takanawa Office, 3F, PMO Takanawa Gateway, 2-19-17,
Takanawa, Minato-Ku, Tokyo, 108-0074, Japan
Tel: +81-3-6721-7478 Fax: +81-3-5424-1021

KOGANEI INTERNATIONAL AMERICA, INC

39300 Civic Center Dr Suite 280 Fremont, CA 94538, U.S.A.
Tel: 510-744-1626 Fax: 510-744-1676

SHANGHAI KOGANEI INTERNATIONAL TRADING CORPORATION

Room 2606-2607, Tongda Venture Building No.1, Lane 600, Tianshan Road, Shanghai,
200051, China
Tel: 021-6145-7313 Fax: 021-6145-7323

KOGANEI KOREA CO., LTD.

Cosmo KT&G Bldg., 3F, Maesanno 2-ga, Paldal-gu, Suwon-si, Gyeonggi-do, 442-082, Korea
Tel: 031-246-0414

KOGANEI-PORNCHAI CO., LTD.

89/174 Moo 3, Vibhavadee Rangsit Road, Talad Bangkhen, Laksi, Bangkok, 10210, Thailand
Tel: 02-551-4025 Fax: 02-551-4015

KOGANEI ASIA PTE. LTD.

7500A Beach Road #06-320 The Plaza Singapore 199591
Tel: 65-6293-4512 Fax: 65-6293-4513