

KOGANEI

**iB-Move
Teaching Box
IBM2A-T1**

Instruction Manual Ver. 1.1

Contents

1. Outline	2
2. Appearance, names and functions of parts	2
3. Specifications	
3-1. System configuration.....	3
3-2. Specifications	3
3-3. Wiring specifications	4
3-4. Communication parameters.....	4
4. Method of use	
4-1. Connecting to the iB-Move controller	5
4-2. Connecting the power supply	5
4-3. Operation by the teaching box.....	5
5. Method of operation	
5-1. Select mode	6
5-2. Setting (SET) mode	7
5-2-1. Edit (EDIT) mode	8
5-2-1-1. Point setting mode.....	9
5-2-1-2. Parameter setting mode	10
5-2-2. Initialize (INIT) mode.....	11
5-3. Operation (RUN) mode.....	12
5-3-1. Origin return (ORG) mode	13
5-3-2. Operation (MOV) mode	14
5-3-3. Current instructed position check mode	15
5-4. Help (HE) mode	15
5-4-1. Version information (VER) mode	16
5-4-2. Language selection (LAN) mode	16
5-4-3. Alarm/error history (ER) mode	16
5-5. Easy mode	17
6. Communication error mode	18

1. Outline

Thank you for purchasing the teaching box for Koganei iB-Move. This manual describes the features and how to use the iB-Move teaching box. Be sure to thoroughly read the content of this manual to ensure correct use.

This teaching box is exclusively for the iB-Move controller.

You can also set and initialize parameters and points, and execute point moves and teaching moves using this teaching box.

2. Appearance, names and functions of parts

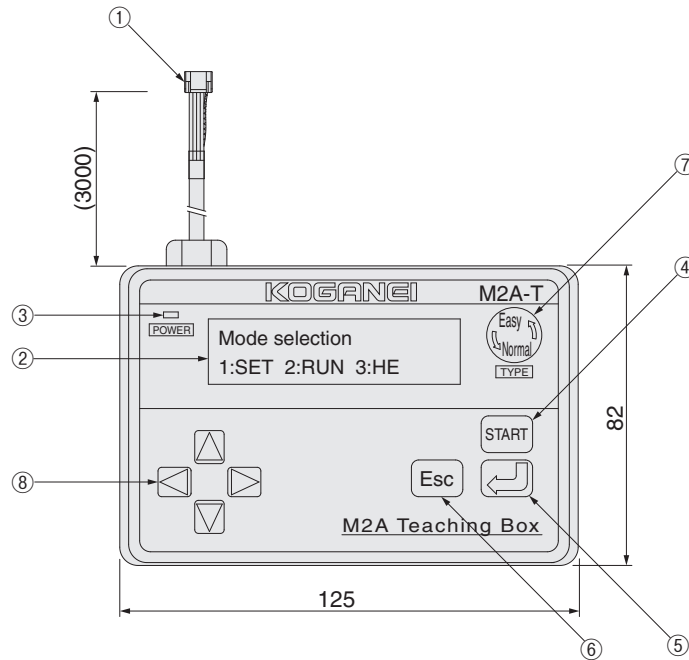

① RS-485 cable (CN1)

This cable is connected to the COM connector of the controller M2A-C1-A1.

② LCD display: 16 characters, 2 lines

Data is displayed in this screen.

③ Power LED indicator

This LED lights when power is being supplied.

④ Start key

Press this key to operate the controller M2A-C1-A1.

⑤ Enter key

Press this key to apply setting data or move to the next screen.

⑥ Escape key

Press this key to go back to the previous screen.

⑦ Type selection key

This key switches between the Normal and Easy modes.

⑧ Left/right/up/down keys

Press these keys to move the data cursor displayed on the LCD or change numerical values.

3. Specifications

3-1. System configuration

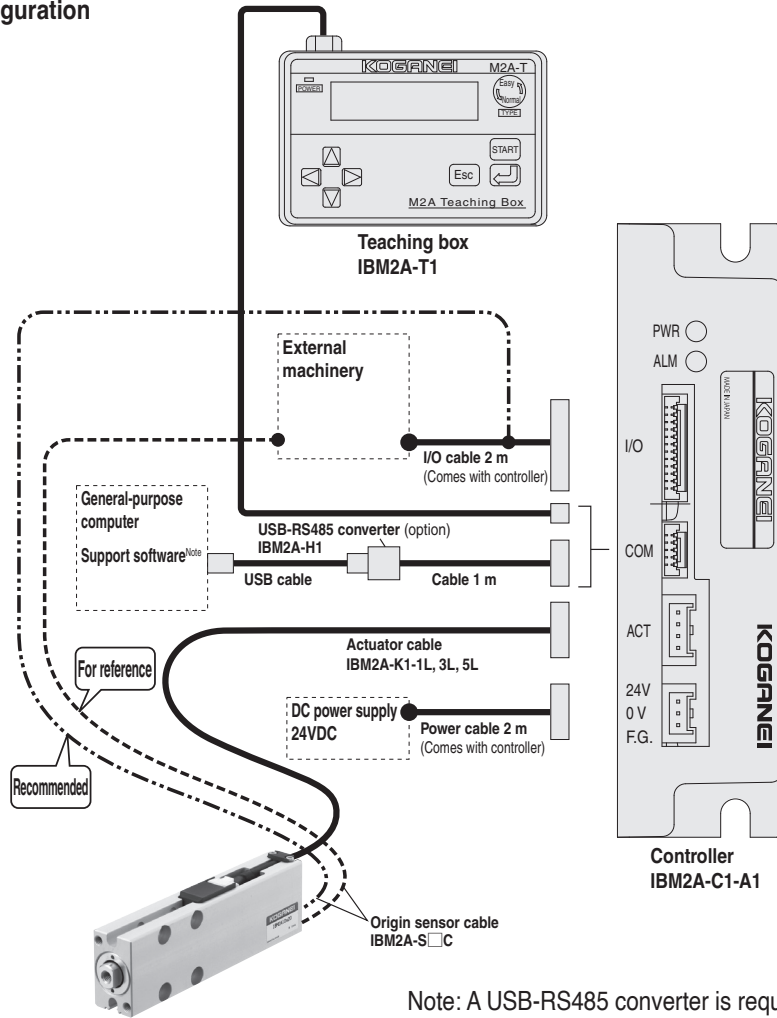

Note: A USB-RS485 converter is required to use the computer support software that comes with the product.

3-2. Specifications

Item		Model	IBM2A-T1
Power	Power supply		Supplied from controller
	voltage		50 mA max.
Indicators	Consumption current		LCD 16 characters x 2 lines
	Setting display		LED lighted (internal 5V) while power is on
Setting method	Power indicators		Key operations : UP : DOWN : LEFT : RIGHT : ENTER : ESCAPE : START : Type selection
Communication protocol			RS-485 compliant
General			0 to 40°C [32 to 104°F]
	Operating temperature		35 to 80% RH (Non-condensation)
	Operating humidity		-10 to 65°C [14 to 149°F]
	Storage temperature		IEC61000-4-4 Power line/communication line 1 KV (Level 2)
	Noise resistance		Main unit: 200 g [7.05 oz]
Applicable controller model			IBM2A-C1-A1

3-3. Wiring specifications

- When connected to controller **IBM2A-C1-A1**

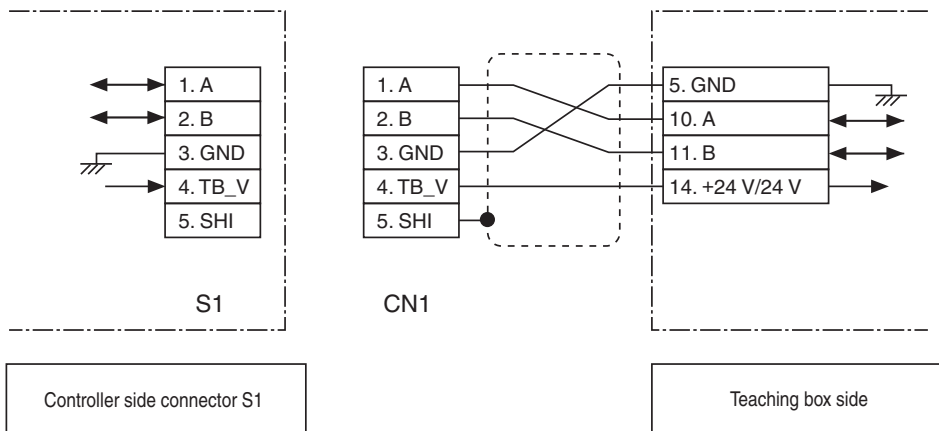

3-4. Communication parameters

Item	Specifications
Baud rate	230.4 kbps
Stop bit	1
Start bit	1
Parity bit	None
Data bit length	8
Communication protocol	Half-duplex, asynchronous

4. Method of use

4-1. Connecting to the iB-Move controller

- Connect the RS-485 cable (CN1) on the teaching box to the RS-485 connector (S1) on the iB-Move controller. (The power cable, motor cable and I/O cable must be connected to the iB-Move controller in addition to the RS-485 cable. Check cable connections thoroughly.)

4-2. Connecting the power supply



- Next, connect the power supply (24VDC) to the iB-Move controller.
(Power is supplied to the teaching box from the iB-Move controller.)
- If the POWER LED on the teaching box is lighted, this means that power is being supplied normally.

4-3. Operation by the teaching box

- Modes that can be selected at a particular time are displayed on the second row of the display screen.

In example A (Select mode), three modes can be selected,

1: SET 2: RUN 3: HE.

Select the desired mode using the   keys.



The selected number flashes.

- If you press the Enter key in screen A, you go down to a lower level of the menu hierarchy.

To return to the previous level of the menu hierarchy, press the Escape key.

- In screen D, input the desired number.

Select the digit by the   keys. The selected digit flashes.

Increase or decrease numbers by the   keys.

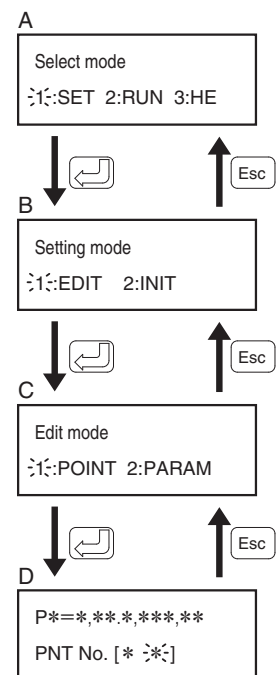

Caution: When operating the teaching box, do not use I/O custom commands on the controller. If an I/O custom command arrives from the controller while you are operating the teaching box, the teaching box might output an erroneous display. I/O custom commands on the controller can be used even while the teaching box is connected.

Do not pull on the cables when disconnecting them from the COM connector on the controller or the cable connector on the teaching box. Doing so might break the cables.

5. Method of operation

You can use the teaching box to change and initialize parameters and points, operate the actuator, check the error history and version information, and perform other operations.

For details on parameter settings and errors, refer to the instruction manual for the actuator main unit.

The Easy mode and the Normal mode can be switched by pressing the  key.

5-1. Select mode

- In the [Select mode] screen, select one of the following by the left/right key,
 - 1: SET (edit/initialize)
 - 2: RUN (operation/instructed position monitor)
 - 3: Select HE (version check, alarm/error history)and apply the setting by the Enter key.

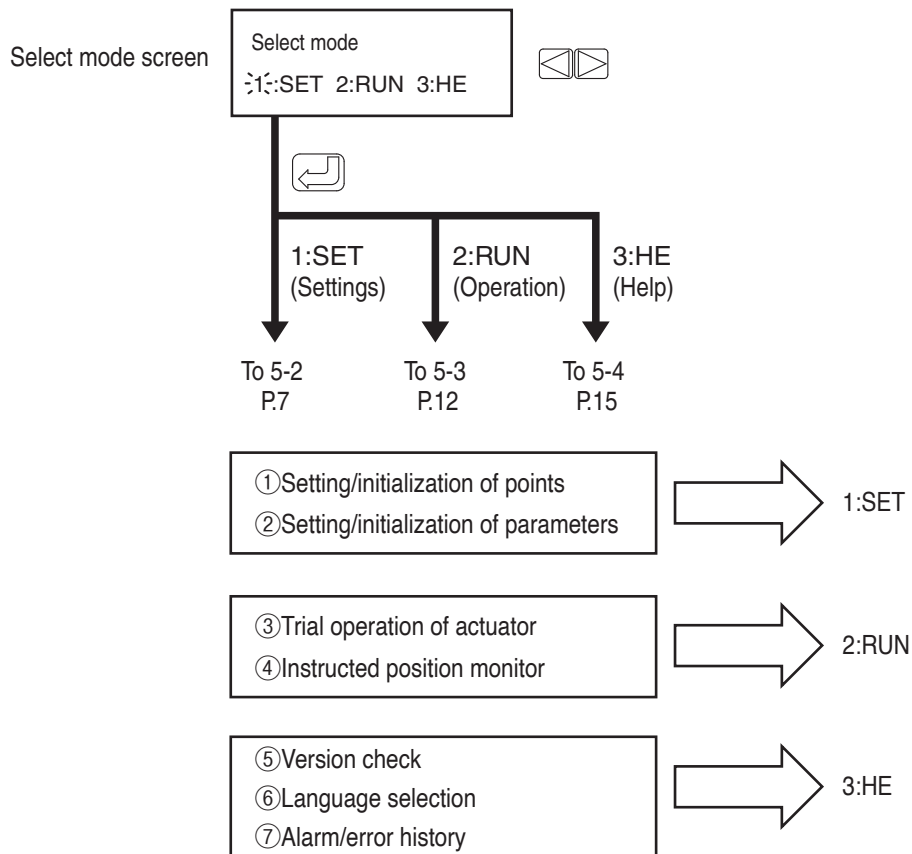

5-2. Setting (SET) mode

In this mode, you edit and initialize points and parameters.

- In the [Select mode] screen, select 1:SET by the left/right key. Make 1:SET flash, and apply the setting by the Enter key.
- Next, in the [Setting mode] screen, Select 1:EDIT (edit) or 2:INIT (initialize) by the left/right key, and apply the setting by the Enter key.
- From here on, edit and initialize points or parameters according to <5-2-1> Edit mode and <5-2-2> Initialize mode.

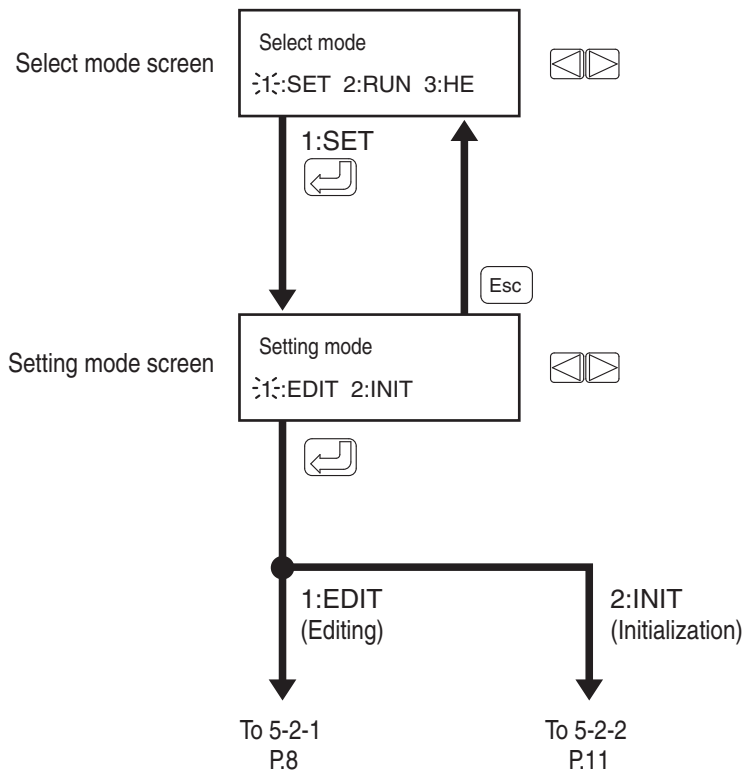

5-2-1. Edit (EDIT) mode

In this mode, set points and parameters.

- In the [Setting mode] screen, select 1:EDIT by the left/right key. Make 1:EDIT flash, and apply the setting by the Enter key.
- Next, in the [Edit mode] screen, Select 1:POINT (point setting) or 2:PARAM (parameter setting) by the left/right key, and apply the setting by the Enter key.
- From here on, set points and parameters according to the <5-2-1-1> Point setting mode (P.9) and <5-2-1-2> Parameter setting mode (P.10).

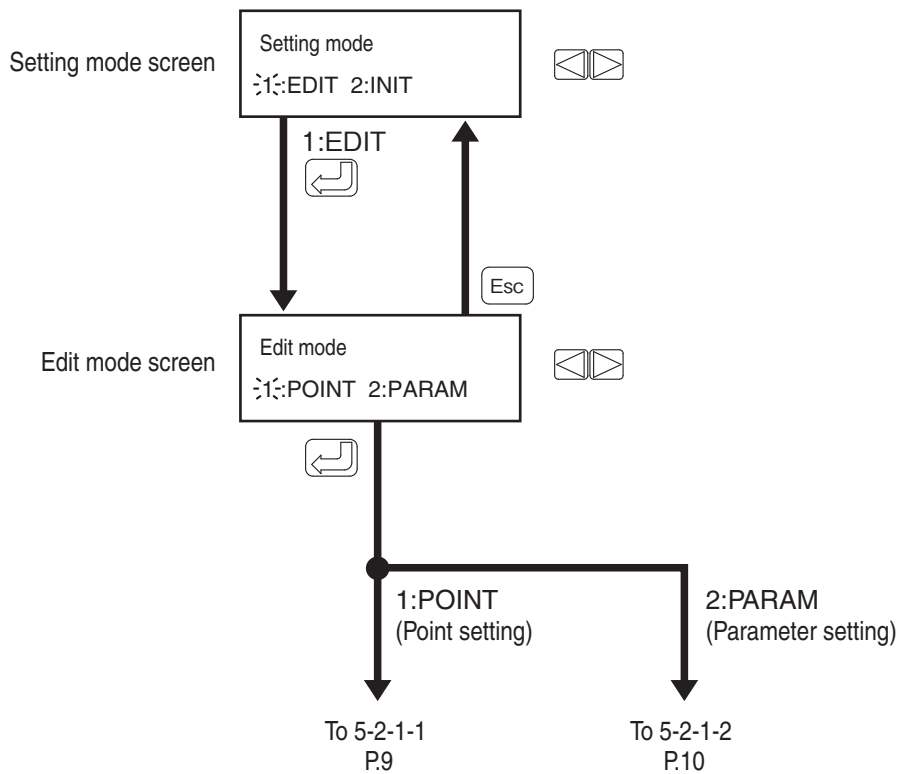

5-2-1-1. Point setting mode

In this mode, you write points.

- In the [Edit mode] screen, select 1:POINT by the left/right key.
- In the [Point number selection] screen, select the point number to set by the up/down key, and apply the setting by the Enter key.
- In the [Position input method selection] screen, select the method for inputting the point position.
- To input the point data:
 - 1: INPUT Input the position as a numerical value.
 - 2: TEACH Move the actuator by the buttons on the teaching box and read the position data.
- In the [Position input] screen,
 - When 1: INPUT is selected, input a numerical value.
 - When 2: TEACH is selected and return-to-origin is not completed, select whether or not to execute origin return in the [Origin return selection] screen, and then move the actuator using the teaching box to determine the point positions.

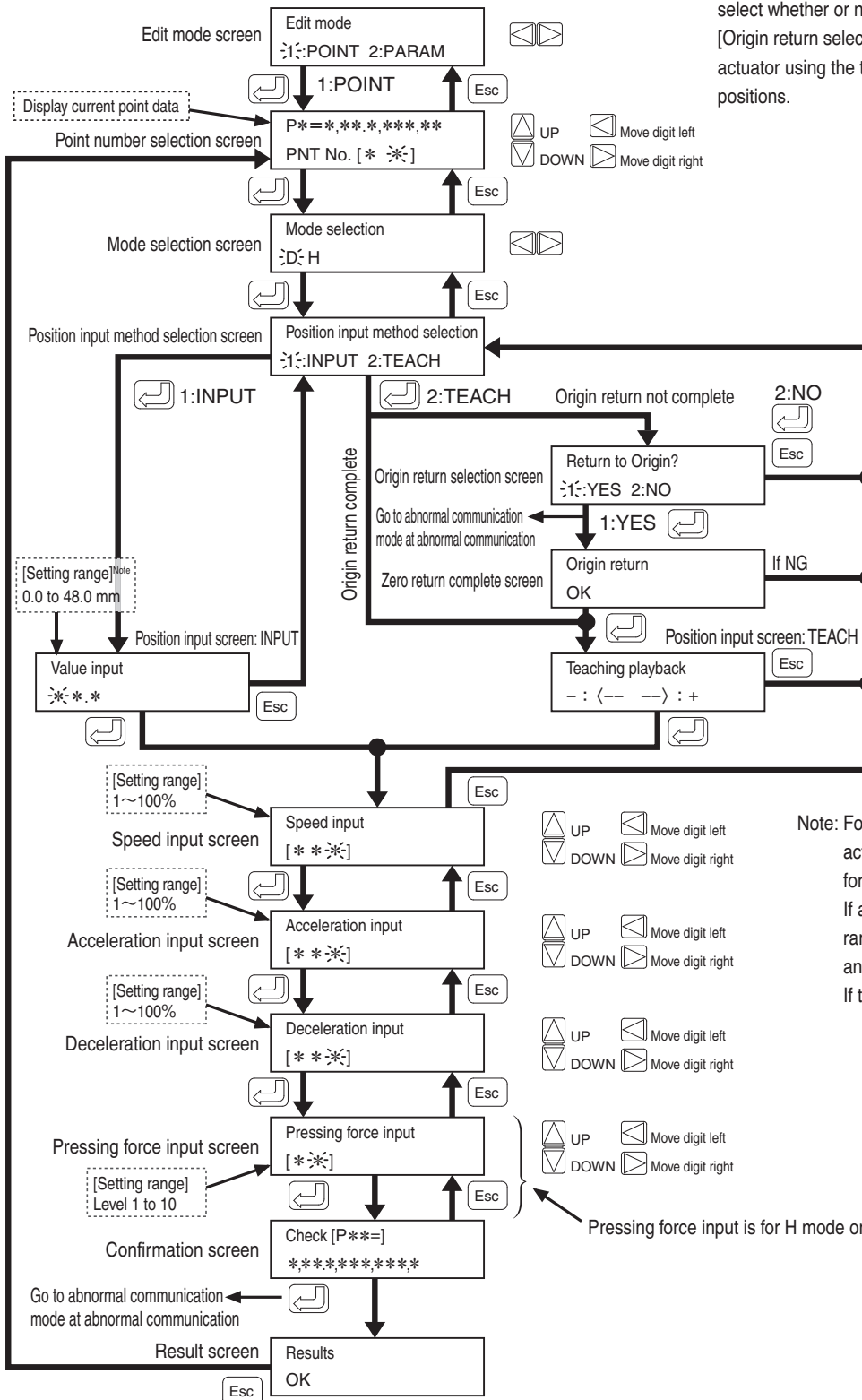

Note: For details on the input ranges of each actuator, refer to the instruction manual for the IBM2A-C1-A1 controller. If a value that is outside the allowable range is input, the selection is not set and "00.0" is displayed. If this happens, check the input range.

5-2-1-2. Parameter setting mode

In this mode, you write parameters.

- In the [Editing mode] screen, select 2:PARAM by the left/right key.
- In the [Parameter writing] screen, select the parameter to set by the up/down key, and apply the setting by the Enter key. (Only parameters that can be written are displayed.)
- The current parameters are displayed in the [Current parameter] screen. To continue writing, press the Enter key, and to cancel writing, press the Escape key. The screen returns to the [Parameter writing] screen.
- In the [Change parameter] screen, change the parameters.
 - To increment numbers: Up key
 - To decrement numbers: Down key
 - To move the number digit: Left/right keys
- When you have finished changing the number settings with the up/down key, press the Enter key to write the parameters.
- For details on parameters that can be written, refer to the instruction manual for the controller.

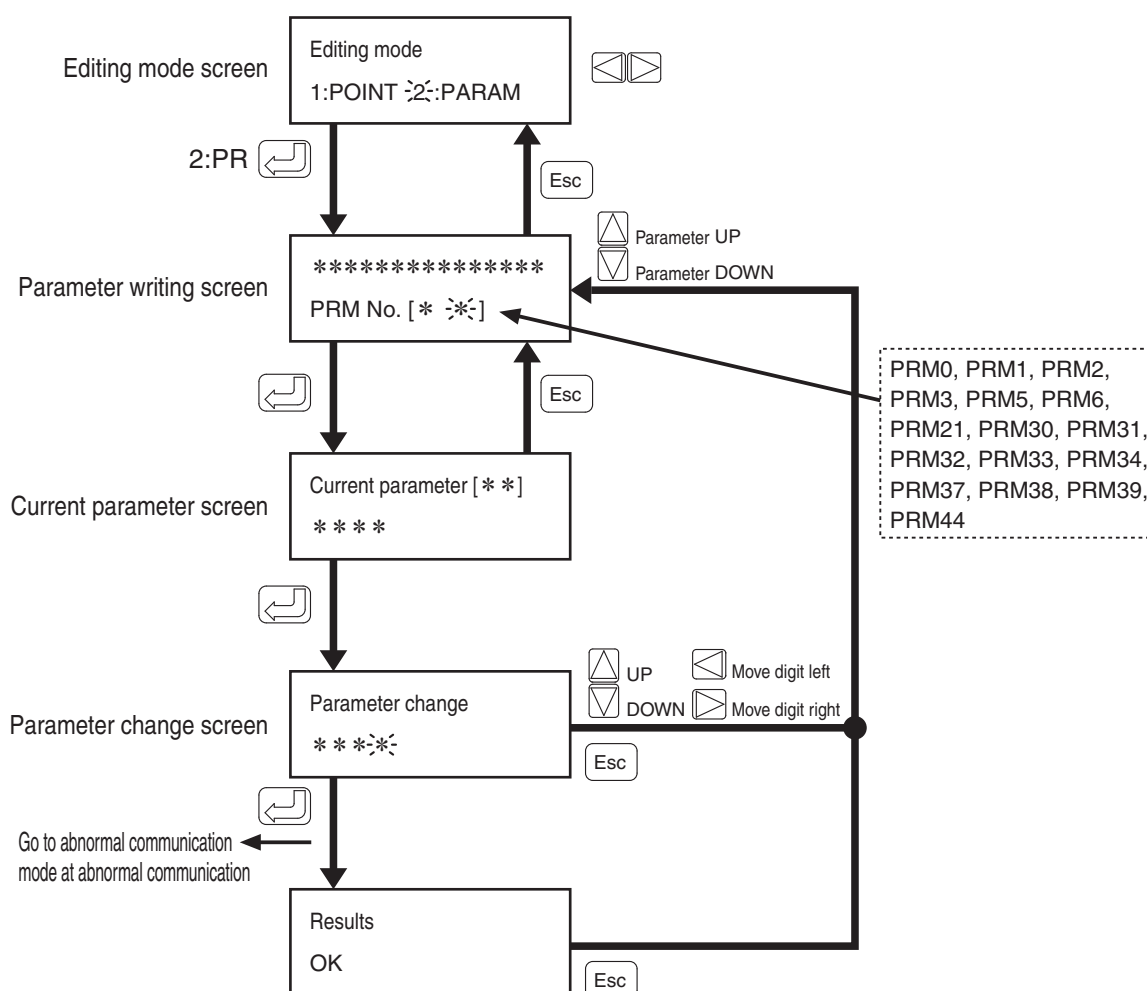

5-2-2. Initialize (INIT) mode

In this mode, you initialize the point and parameter data.

- In the [Setting mode] screen, select 2:INIT by the left/right key. Make 2:INIT flash, and apply the setting by the Enter key.
- In the [Initialize mode] screen, Select 1:POINT (point setting) or 2:PARAM (parameter setting) by the left/right key, and apply the setting by the Enter key.
- In the [Confirmation] screen, be sure to check the data to be initialized before it is initialized.

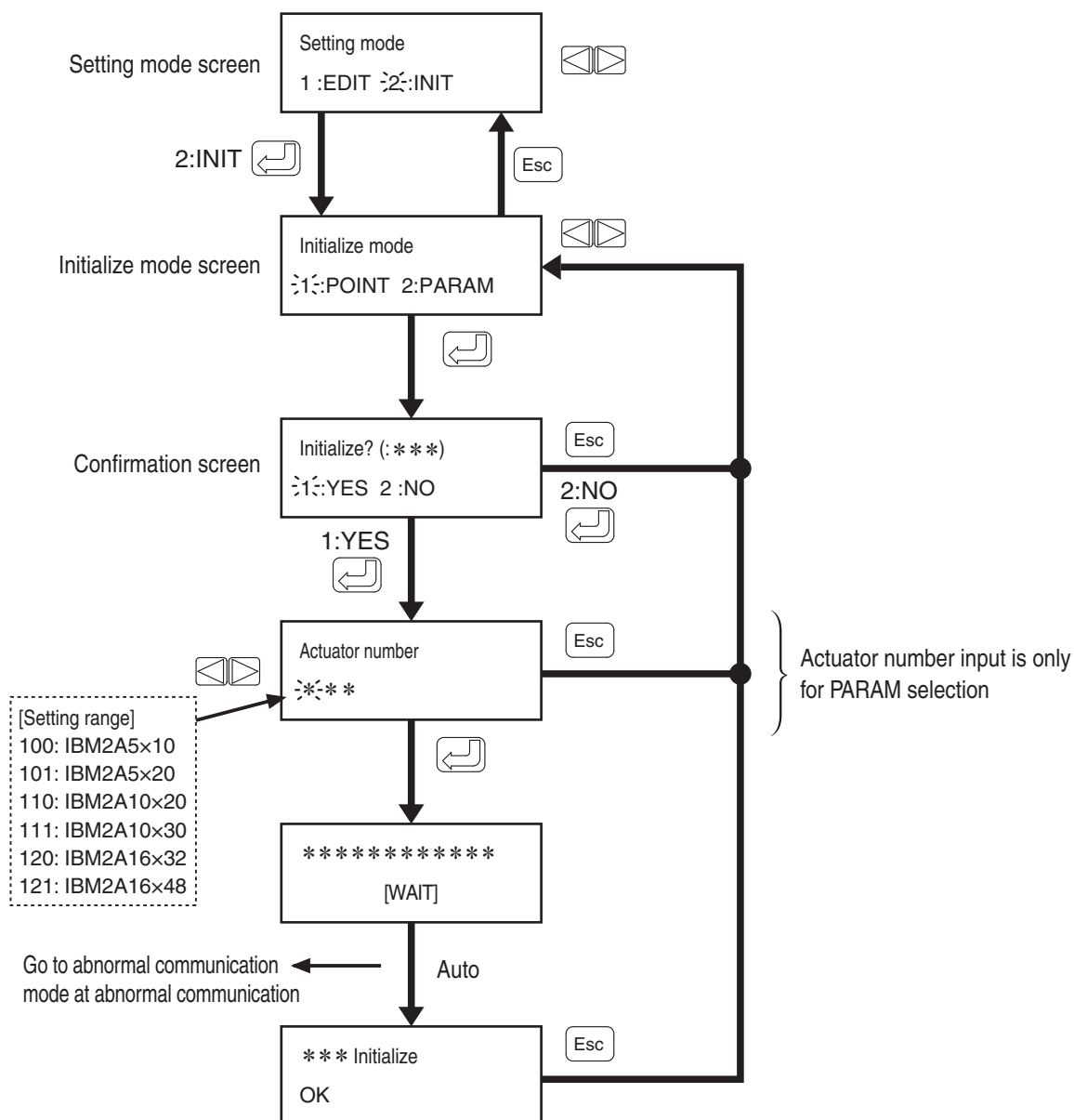

5-3. Operation (RUN) mode

In this mode, execute origin return, point operation and checking of current instructed position.

- In the [Select mode] screen, select 2:RUN by the left/right key. Make 2:RUN flash, and apply the setting by the Enter key.
- In the [Run mode] screen, select 1:ORG, 2:MOV or 3:PO by the left/right key.
- From here on, execute origin return, point operation and checking of current instructed position according to <5-3-1>, <5-3-2> and <5-3-3>.

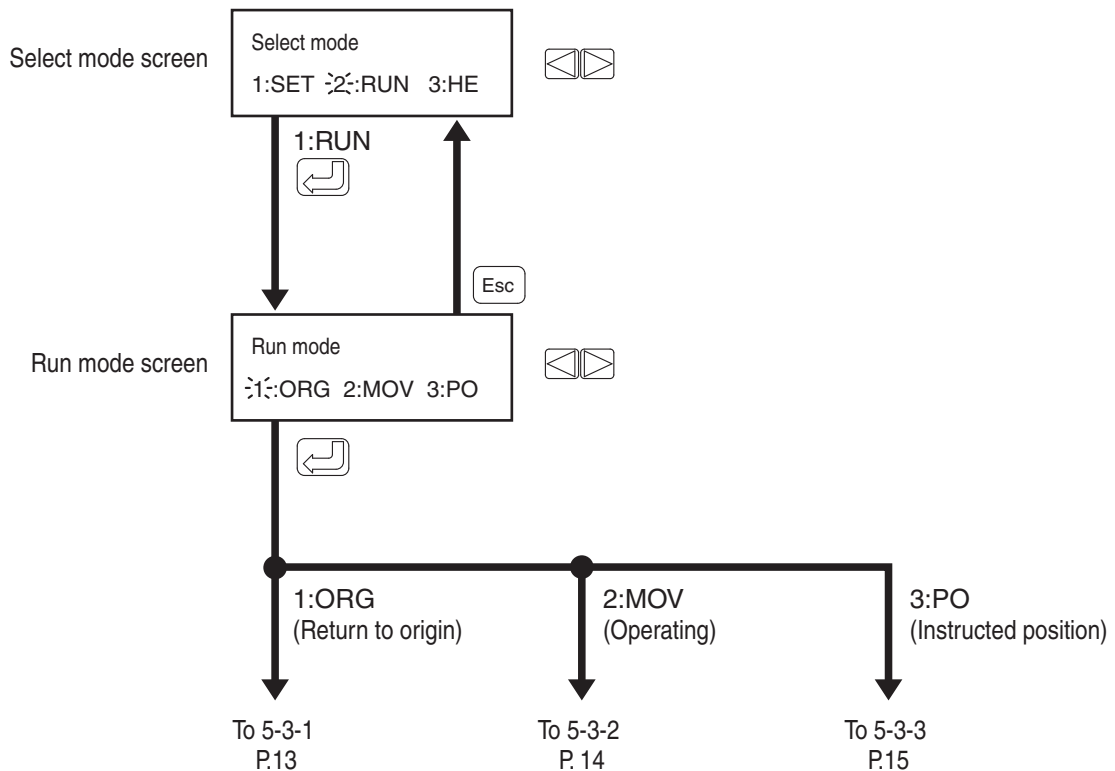

5-3-1. Origin return (ORG) mode

In this mode, you execute origin return.

- In the [Run mode] screen, select 1:ORG by the left/right key. Make 1:ORG flash, and apply the setting by the Enter key.
- In the Origin return check screen, select whether or not to execute origin return.

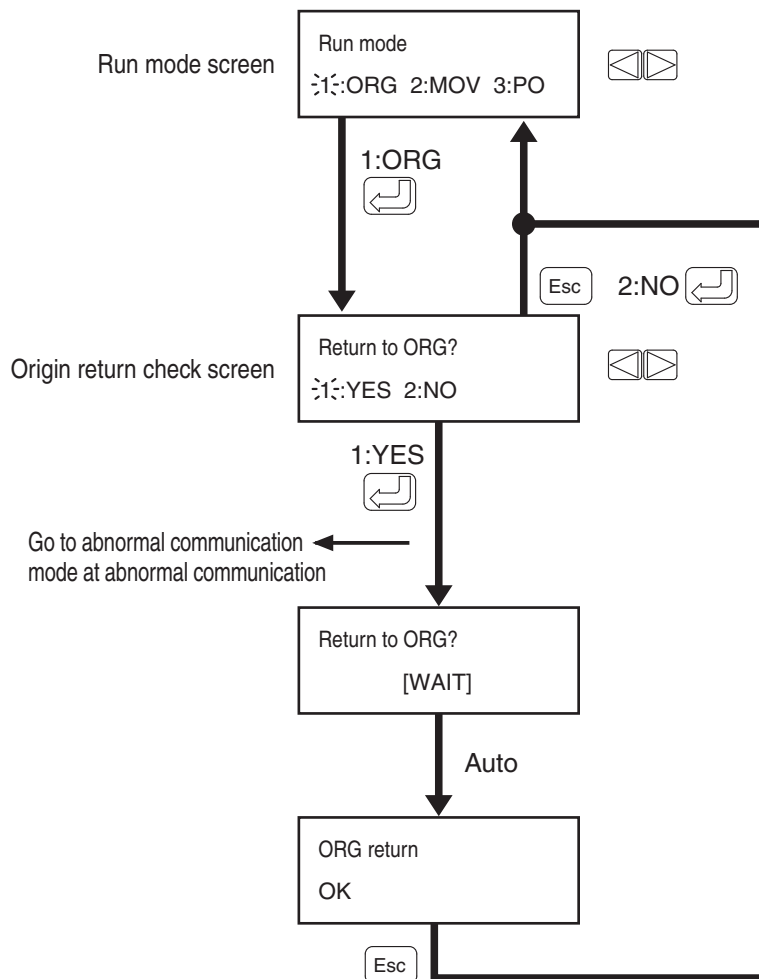

5-3-2. Operation (MOV) mode

In this mode, you execute point operation.

- In the [Operation mode screen], select 2:MOV by the left/right key. Make 2:MOV flash, and apply the setting by the Enter key.
- In the Point number selection screen, select the move destination point.

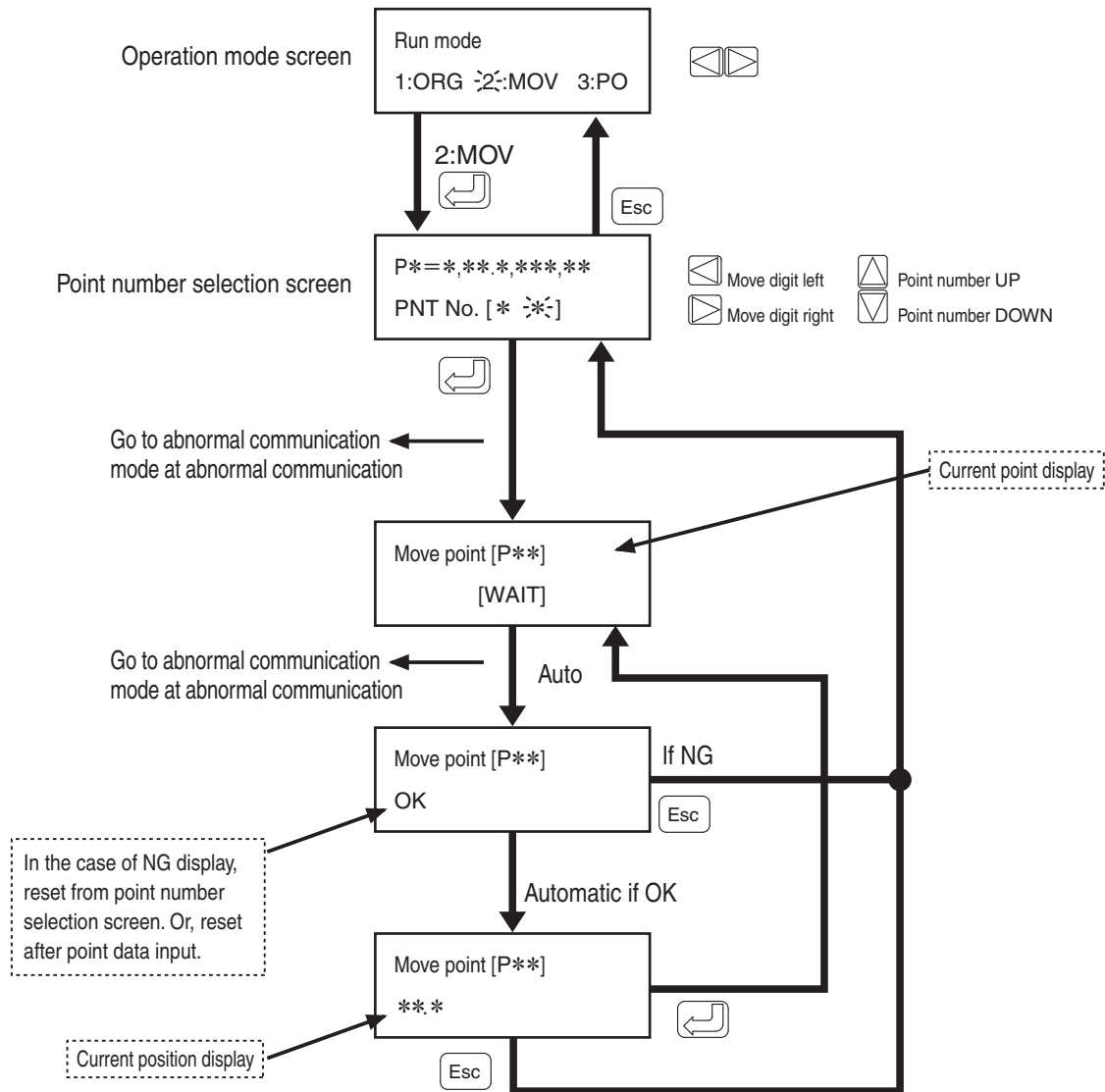

5-3-3. Current instructed position check (PO) mode

In this mode, you display the current instructed position on the screen.

- In the [Operation mode screen], select 3:PO by the left/right key. Make 3:PO flash, and apply the setting by the Enter key. The current instructed position confirmation is displayed.
- Return to the [Operation mode screen] by pressing the Escape key.

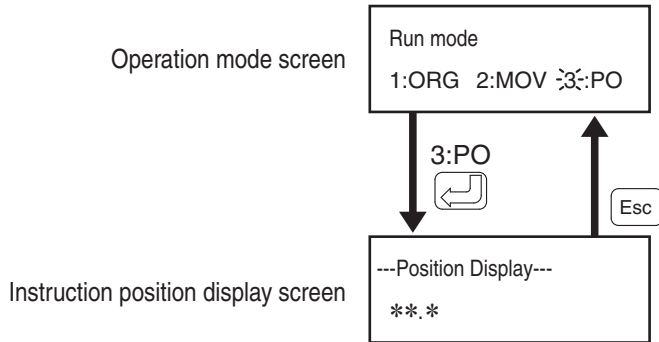

5-4. Help (HE) mode

In this mode, you can check the version of the currently connected controller and alarms, and do other operations.

- In the [Select mode screen], select 3:HE by the left/right key. Make 3:HE flash, and apply the setting by the Enter key.
- In the [Help mode screen], select 1:VER, 2:LAN or 3:ER by the left/right key.
- From here on, check the control version and alarms according to <5-4-1>, <5-4-2> and <5-4-3>.

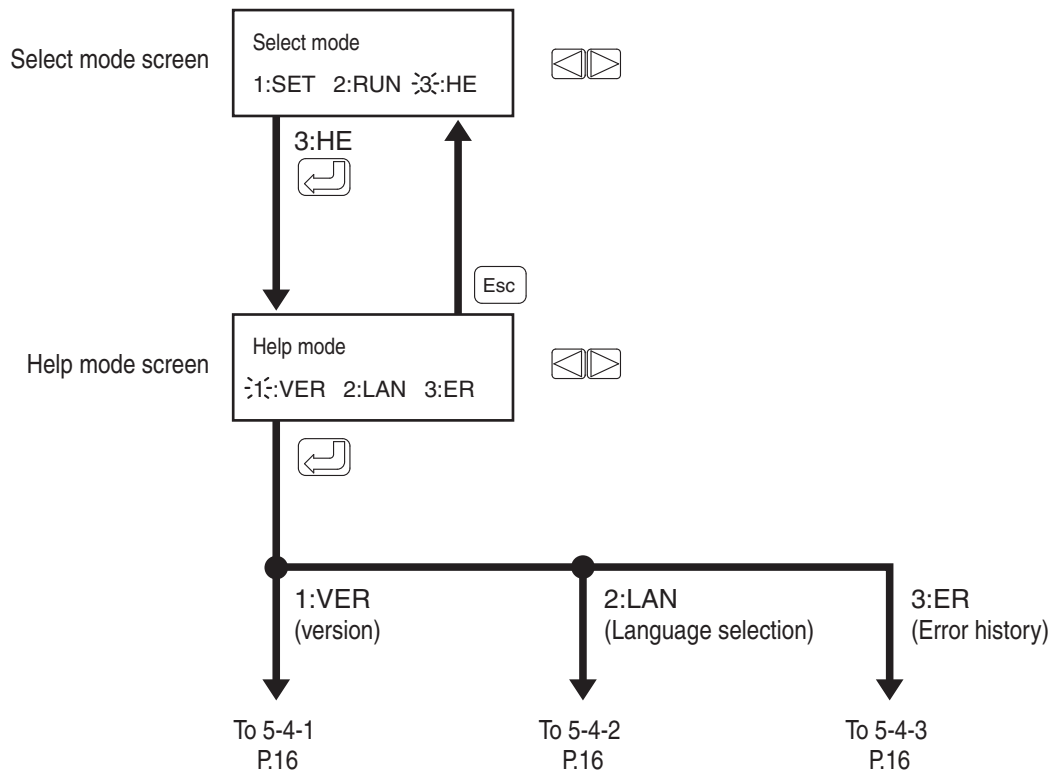

5-4-1. Version information (VER) mode

- In the [Help mode] screen, select 1:VER by the left/right key. Make 1:VER flash, and apply the setting by the Enter key.

The controller version is displayed.

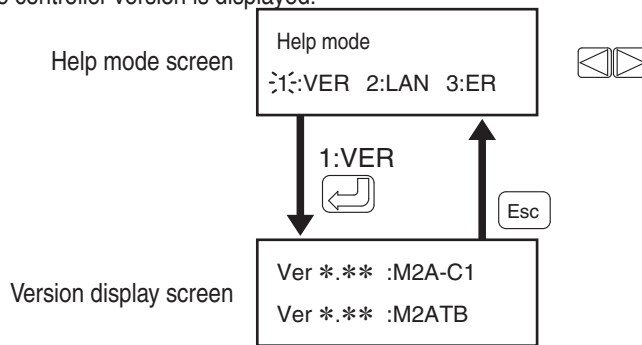

5-4-2. Language selection (LAN) mode

- In the [Help mode] screen, select 2:LAN by the left/right key. Make 2:LAN flash, and apply the setting by the Enter key.

Select the language with the left/right key, and press the Enter key.

1: JPN (Japanese) 2: ENG (English)

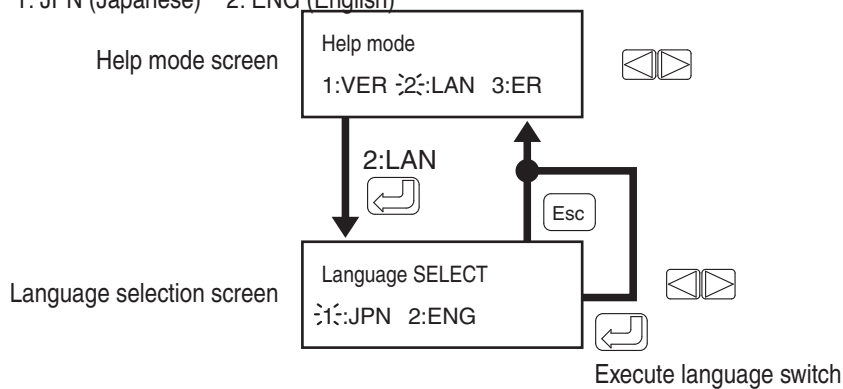

5-4-3. Alarm/error history (ER) mode

- In the [Help mode] screen, select 3:ER by the left/right key. Make 3:ER flash, and apply the setting by the Enter key.

The error history is displayed in the [Error history] screen.

You can view a history of the past 16 errors using the up/down key.

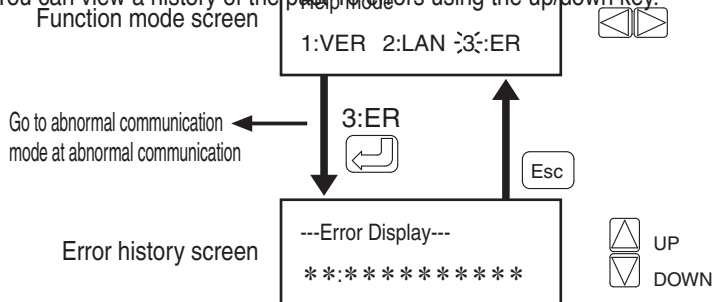

5-5. Easy mode

In this mode, you can easily set the point data and execute operations.

You can also acquire the current instructed position.

- In the [Easy mode] screen, select 1:EDIT by the left/right key. Make 1:EDIT flash, and apply the setting by the Enter key.

When return-to-origin is not completed, execute checking of origin return.

After the origin return completes, the screen moves to the [Setting mode] screen.

- In the [Setting mode] screen, set the mode, instructed position and speed (acceleration/deceleration/pressing force).

Select these items with the up/down/left/right keys, and apply the settings by the Enter key to write the data.

Execute specified point operation by pressing the **START** key.

- To acquire the current instructed position, select 2:POS in the [Easy mode] screen with the left/right key.

Make 2:POS flash, and apply the setting by the Enter key.

For details on operations from here on, see P. 15.

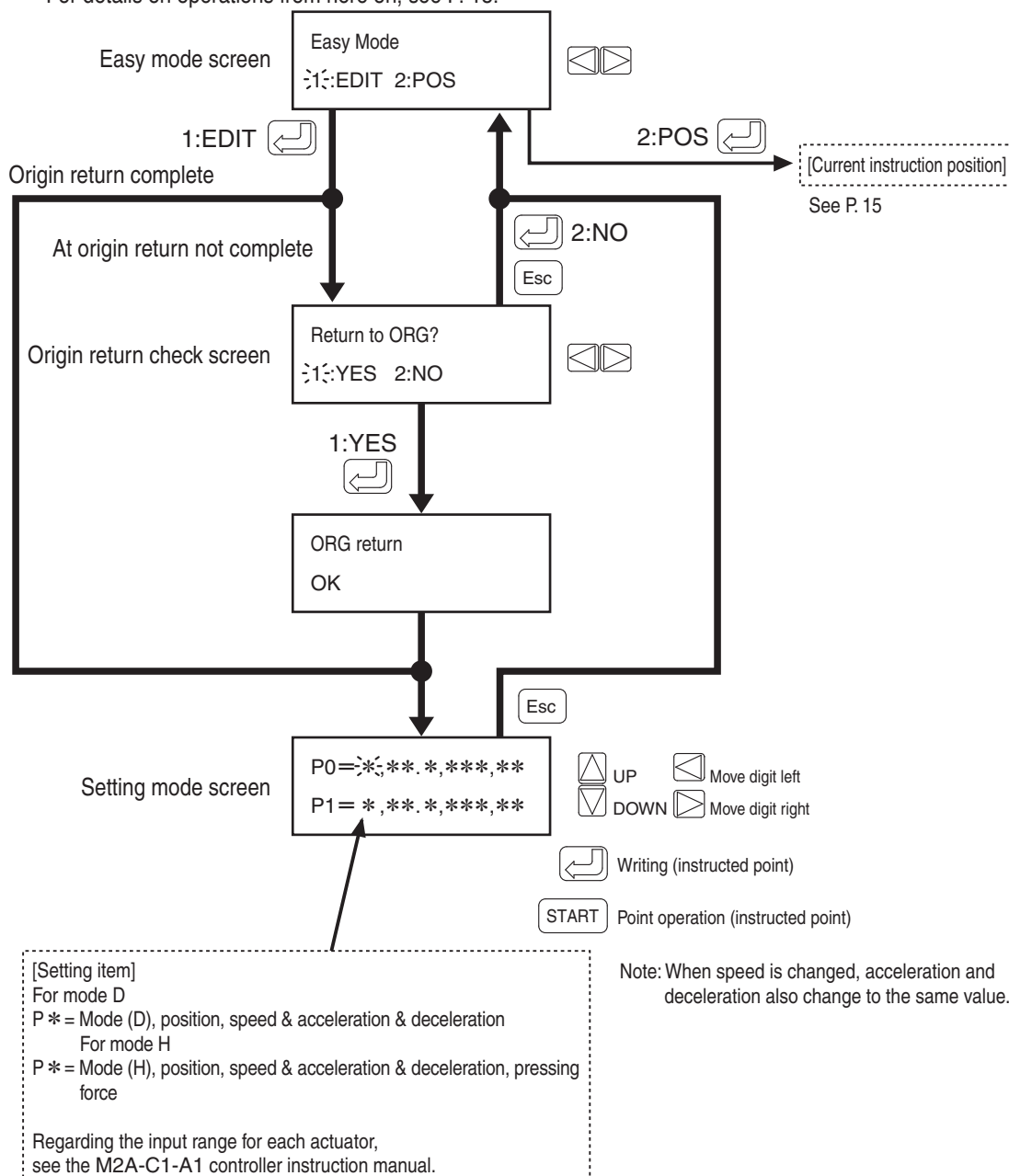

6. Communication error mode

In this mode, you execute communication while [WAIT] is displayed on the second row of the display screen. If [WAIT] continues to be displayed for some reason or another even though the specified time is reached, or when the display in the display screen is not the appropriate display, a communication error has occurred. (Probable causes include a severed communication cable and no response returned from the controller.)

As shown in the example below, return to the [Select mode screen], and check the communication cable or actuator.

Example

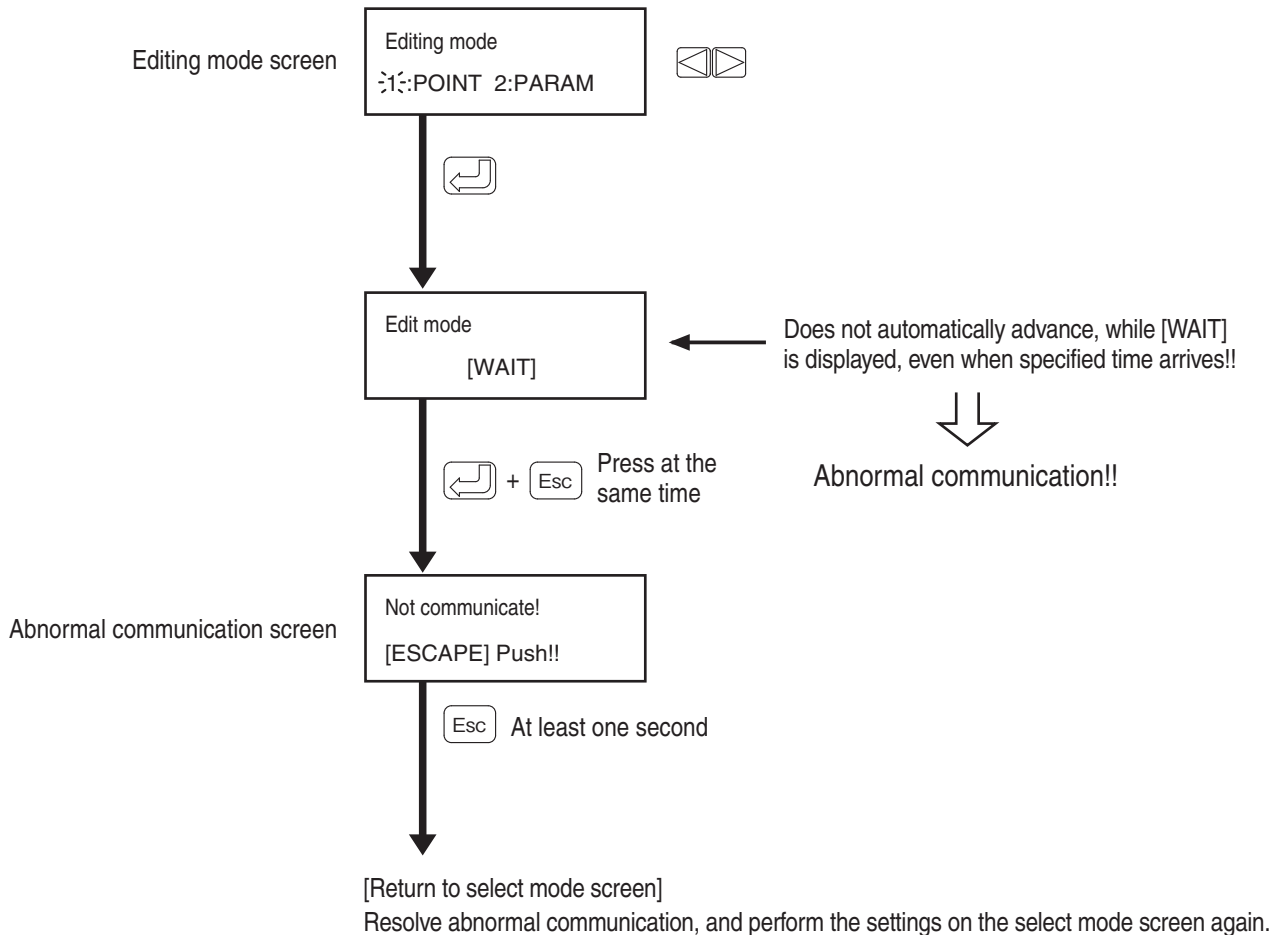

Note: [WAIT] is displayed even during origin return or other movement. If you attempt to press the Enter key and the Escape key simultaneously in this state, the display will change to the [Communication error] screen regardless of whether or not operation is normal.

Revision History

Ver 1.1

P3. Changed to a system configuration with the origin position sensor cable installed.

P5. Added a caution note.

P10. Added parameters PRM3, PRM6, and PRM33.

If parts of this document are unclear or you have technical questions, contact the following:

<<Inquiries>>

Koganei Corporation, Overseas Group

Takanawa Office, 3F, PMO Takanawa Gateway, 2-19-17, Takanawa, Minato-Ku, Tokyo, 108-0074, Japan

TEL : +81-3-6721-7478 FAX : +81-3-5424-1021

iB-Move Teaching Box IBM2A-T1

Instruction Manual

December, 2025 Ver. 1.1 X425101

©Koganei Corporation

Duplication or transfer of the content of this document in part or
in whole is forbidden.

URL: <https://www.koganei.co.jp>

E-mail: overseas@koganei.co.jp



KOGANEI CORPORATION

OVERSEAS GROUP

Takanawa Office, 3F, PMO Takanawa Gateway, 2-19-17,
Takanawa, Minato-Ku, Tokyo, 108-0074, Japan
Tel: +81-3-6721-7478 Fax: +81-3-5424-1021

KOGANEI INTERNATIONAL AMERICA, INC

39300 Civic Center Dr Suite 280 Fremont, CA 94538, U.S.A.
Tel: 510-744-1626 Fax: 510-744-1676

SHANGHAI KOGANEI INTERNATIONAL TRADING CORPORATION

Room 2606-2607, Tongda Venture Building No.1, Lane 600, Tianshan Road, Shanghai,
200051, China
Tel: 021-6145-7313 Fax: 021-6145-7323

KOGANEI KOREA CO., LTD.

Cosmo KT&G Bldg., 3F, Maesanno 2-ga, Paldal-gu, Suwon-si, Gyeonggi-do, 442-082, Korea
Tel: 031-246-0414

KOGANEI-PORNCHAI CO., LTD.

89/174 Moo 3, Vibhavadee Rangsit Road, Talad Bangkhen, Laksi, Bangkok, 10210, Thailand
Tel: 02-551-4025 Fax: 02-551-4015

KOGANEI ASIA PTE. LTD.

7500A Beach Road #06-320 The Plaza Singapore 199591
Tel: 65-6293-4512 Fax: 65-6293-4513