

**EtherNet/IP Compliant**

# **Serial Transmission Compatible Manifold**

---

## **User's Manual**

Ver.5.0

**Supported solenoid valves**

- F10 Series
- F15 Series

**EtherNet/IP™**



EtherNet/IP Compliant

# Serial Transmission Compatible Manifold

## User's Manual

This user's manual describes the serial transmission block so that the serial transmission compatible manifold and solenoid valves can be used correctly. See the catalogs for information about the manifolds and the valves.

To use these products correctly, you must first read the documentation.



### CAUTION

This product does not have the appropriate functions to support applications, such as safety equipment or accident prevention systems, that require high levels of safety.

- Do not put the communication cables near or in bundles with power lines.
- This manual is for the F10 and F15 series solenoid valves. Contact us if you are using a different series of solenoid valves.
- For details and precautions regarding EtherNet/IP, refer to the manuals and other documentation about EtherNet/IP related equipment.

ODVA, CIP, CompoNet, ControlNet, DeviceNet, and EtherNet/IP are trademarks of ODVA.

The company and product names mentioned in this document are the trademarks of their respective companies.

# 1 Contents

- 1 Contents .....1
- 2 Revision History .....3
- 3 Glossary .....3
- 4 Major Parts and Functions .....5
  - 4-1 Power, communications, and FG connectors .....5
  - 4-2 Indicator panel.....5
  - 4-3 Hardware switch settings .....6
    - 4-3-1 Network address setting switch, HOLD/CLEAR switch .....6
    - 4-3-2 Host address setting switch.....6
- 5 EDS file .....7
- 6 IP address settings .....7
  - 6-1 Specify using the host address switches.....7
  - 6-2 Use the DHCP server.....8
    - 6-2-1 Network address setting switch, HOLD/CLEAR switch .....8
- 7 Relationship between I/O date allocation and solenoid valves .....9
- 8 Network topology .....10
  - 8-1 Line format .....10
  - 8-2 Star format .....10
  - 8-3 Device level ring format .....11
- 9 CIP class objects .....11
  - 9-1 Identity ( class code : 01 hex ) .....11
    - 9-1-1 Service code .....11
    - 9-1-2 Attribute .....12
    - 9-1-3 Reset service.....12
  - 9-2 TCP/IP interface ( class code : F5 hex ) .....13
    - 9-2-1 Service code.....13
    - 9-2-2 Attribute .....13
  - 9-3 Ethernet Link ( class code : F6 hex ).....15
    - 9-3-1 Service code.....15
    - 9-3-2 Attribute .....15
  - 9-4 Device Level Ring ( class code : 47 hex ) .....16
    - 9-4-1 Service code.....16
    - 9-4-2 Attribute .....16
  - 9-5 Quality of Service ( class code : 48 hex ) .....17
    - 9-5-1 Service code.....17
    - 9-5-2 Attribute .....17
  - 9-6 Discrete Output Point ( class code : 09 hex ) .....17

9-6-1 Service code.....	17
9-6-2 Attribute .....	17
9-6-3 About the number of outputs .....	18
9-7 System Information ( class code : B0 hex ).....	19
9-7-1 Service code.....	19
9-7-2 Attribute .....	19
10 Web page.....	20
10-1 How to use .....	20
11 Specifications .....	21
11-1 General specifications .....	21
11-2 Communicatipn specifications .....	21

## 2 Revision History

Date revised	Description of revision
June 2017	First printing
August 2017	Added glossary Added IP address settings Added network topology Added CIP class objects
January 2018	Correction 9-6-3 About the number of outputs
June 2020	Added precautions when turning power off.
Dec 2021	IP address settings changed.

## 3 Glossary

Terminology	Description
Communication protocol	Defines the communication procedures and protocols for communications on a network.
CIP (Common Industrial Protocol)	Communication protocol that can be shared between DeviceNet, ControlNet, EtherNet/IP, and CompoNet.
IP address	Number for identifying devices on a network. It is configured from the network address and host address.
Network address	Number for identifying a network itself.
Host address	Number for identifying devices within a network.
BOOTP (Bootstrap Protocol)	Communication protocol used by devices on a network to automatically acquire IP addresses from a server.
DHCP (Dynamic Host Configuration Protocol)	Protocol with expanded backward compatibility for BOOTP.
Connection	Method for communications between devices and PLC. Basically this is used for I/O data communications.
EDS file	Information about connections to EtherNet/IP devices.
Flash memory	Memory device that keeps data, even if the power is turned off.
Network topology	Format of connections between devices on a network.
Vendor ID	Unique identifier that indicates a manufacturer, they are different for each communication standard.
MAC address	Identification number that is physically assigned to devices on a network to uniquely identify the devices. They are in a 48 bit format.

10BASE-T,100BASE-TX	Ethernet standard regulated by IEEE802.3. Twisted-pair cables (UTP category 5 or better, STP) are used for this standard.
RPI (Requested Packet Interval)	The interval at which packets are requested. This is set by the communication cycle of the I/O date.
Exclusive owner	This is one of the connection methods for communicating I/O date. When connected in this way, other connection requests are rejected.
UCMM	This stands for unconnected message manager. It uses message communications without using communication methods called connections.
Full duplex communication	Communications are sent and received simultaneously.
Half duplex communication	Communications in which receiving cannot be done while sending, and sending cannot be done while receiving.
Auto negotiations (Auto-negotiation)	Function to automatically optimize communication method and communication speed with aconnected party.
Default gateway	Function that knuws the method that packets are transmitted to other networks.
MDI, MDI-X, Auto-MDIX	These are communication connector specifications that define types of cables (straight, cross, etc.). The product has an automatic switching function, so it is not necessary to determine how to use cables or differentiate specifications.
ACD (Address Conflict Detection)	Function to detect conflicting IP addresses.
HTTP (Hypertext Transfer Protocol)	Communication protocol used between web browsers and web servers.

## 4 Major Parts and Functions

### 4-1 Power, communications, and FG connectors

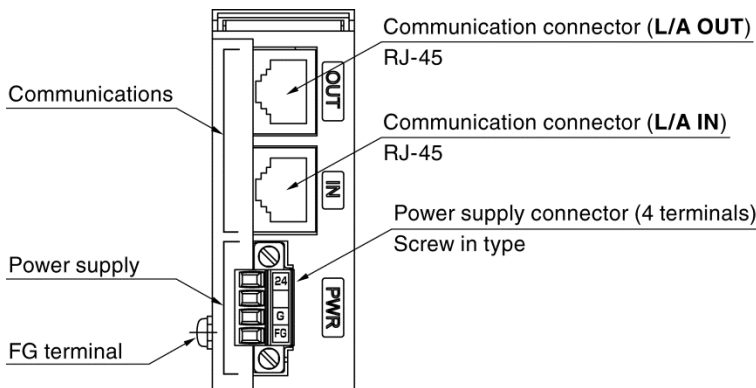

#### Communications (RJ-45 communication connector)

- J1...TX+
- J2...TX-
- J3...RX+
- J6...RX-

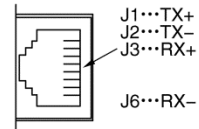

Power supply (applicable wire sizes : AWG 28 to 16, tightening torque : 0.22 to 0.25 N · m [1.95 to 2.21 in · lbf])

24...24 VDC + terminal

G...24 VDC - terminal

FG...Frame ground terminal

FG terminal (tightening torque : 0.49 N · m [4.34 in · lbf])

Ground terminal connection (connected internally to the FG on the power supply terminal)

\* Do not turn power off within 10 seconds after starting power supply.

### 4-2 Indicator panel

#### Display panel

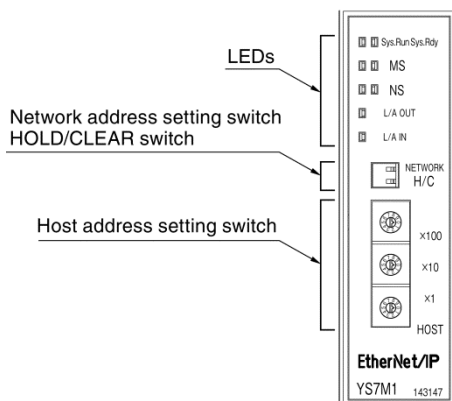

#### LED displays and descriptions

Indicator	LED State	Description
Sys.Run/Sys.Rdy	<input type="checkbox"/> off/off	Transmission block power off
	<input checked="" type="checkbox"/> Lit green/off	Transmission block normal operation
MS	<input type="checkbox"/> Off	Transmission block power off
	<input checked="" type="checkbox"/> Flashing green	Initialization incomplete state
	<input checked="" type="checkbox"/> Lit green	Normal operation
	<input checked="" type="checkbox"/> Flashing red	Recoverable errors
NS	<input checked="" type="checkbox"/> Lit red	Unrecoverable error
	<input type="checkbox"/> Off	Transmission block power off or IP address not set
	<input checked="" type="checkbox"/> Flashing green	Transmission block is online without an established connection
	<input checked="" type="checkbox"/> Lit green	Transmission block is online and has established connections
L/A	<input checked="" type="checkbox"/> Flashing red	Connection timeout
	<input checked="" type="checkbox"/> Lit red	Transmission block detected a duplicate IP address
	<input type="checkbox"/> Off	Not connected
	<input checked="" type="checkbox"/> Lit green	Normal communication

\* The illustration shows the panel for the YS7M1, but the YS7M3 panel is the same.

### 4-3 Hardware switch settings

This section explains the specifications for the hardware switches on the YS7Mn.

#### 4-3-1 Network address setting switch, HOLD/CLEAR switch

ON ←

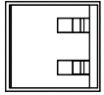

NETWORK  
H / C

Switch	Description
NETWORK	<p>Sets the network address in the IP address.</p> <p>Use this when setting the IP address using a physical switch.</p> <p>For details, please refer to 「6 IP Address settings」 .</p> <p>ON : 192.168.1. <input type="checkbox"/></p> <p>OFF : 192.168.0. <input type="checkbox"/> *1</p>
H / C	<p>Selects the output format when communications breakdown and when a connection cannot be established.</p> <p>H : Holds the last output (hold)</p> <p>C : Clears the output *1</p>

\*1 Factory setting

#### 4-3-2 Host address setting switch

The host address setting switches can set the host address in the IP address.



x100



x10

Exa 192.168.1.   
Host address



x1

Setting value	Description
000 *1	<p>Set IP address by software.</p> <p>Refer to "6 IP address settings" for details.</p>
001-254	Sets the host address.
255-999	Acquires IP address from DHCP server.

\*1 Factory setting

For details, please refer to 「6 IP Address settings」 .

## 5 EDS file

Download from <https://oficial.koganei.co.jp/>.

## 6 IP address settings

Select depending on the address you want to set.

Set address	Set method
192. 168. 0 1 ~ 254 or 1	6-1 Set by physical switch <Recommended>
Beside the above	6-2 Set by support software

### 6-1 Set by physical switch

Addresses are specified directly by a combination of network address switches and host address switches.

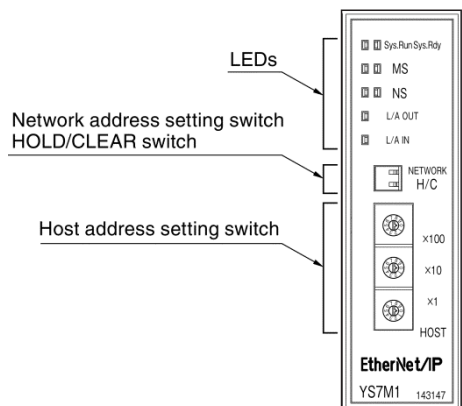
1	Make sure that the manifold solenoid valve power supply is OFF.																							
2	<p>Based on the figure on the right, check the location of the host address setting switch and the network address switch.</p> 																							
3	<p>Change the network address switch and the host address setting switch. The range of possible settings is as follows.</p> <table border="1" data-bbox="255 1568 1436 2016"> <thead> <tr> <th>NETWORK</th> <th>HOST</th> <th>IP address</th> <th>Subnet mask</th> <th>Gateway</th> </tr> </thead> <tbody> <tr> <td> </td> <td> </td> <td>192.168.0.1 ~ 192.168.0.254</td> <td rowspan="2">255.255.255.0</td> <td rowspan="2">0.0.0.0 ( Invalid )</td> </tr> <tr> <td> </td> <td> </td> <td>192.168.1.1 ~ 192.168.1.254</td> </tr> <tr> <td> </td> <td> </td> <td>192.168.1.1 ~ 192.168.1.254</td> <td></td> <td></td> </tr> <tr> <td></td> <td>Combination of 1 ~ 254</td> <td></td> <td></td> <td></td> </tr> </tbody> </table>	NETWORK	HOST	IP address	Subnet mask	Gateway			192.168.0.1 ~ 192.168.0.254	255.255.255.0	0.0.0.0 ( Invalid )			192.168.1.1 ~ 192.168.1.254			192.168.1.1 ~ 192.168.1.254				Combination of 1 ~ 254			
NETWORK	HOST	IP address	Subnet mask	Gateway																				
		192.168.0.1 ~ 192.168.0.254	255.255.255.0	0.0.0.0 ( Invalid )																				
		192.168.1.1 ~ 192.168.1.254																						
		192.168.1.1 ~ 192.168.1.254																						
	Combination of 1 ~ 254																							

The physical switch settings are reflected when the power is turned on.

## 6-2 Set by support software

マニホールド電磁弁電源が OFF 状態で、ホストアドレス設定スイッチを「000」に設定します。

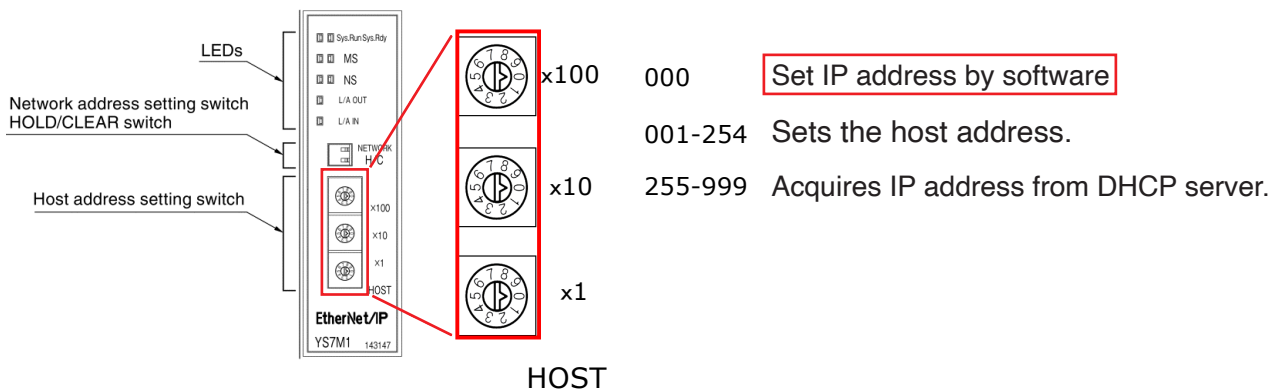

サポートソフトは PLC ベンダーのソフトを使用します。詳細は各社マニュアルを参照してください。

- ・ オムロン社：Sysmac Plug & Work Program ネットワーク接続ガイド
  - ・ キーエンス社：EtherNet/IP 機能ユーザーズマニュアル「5-5 EtherNet/IP 機器エリア」
- 上記以外は Rockwell 社の BOOTP/DHCP Tool を御使用ください。

### 6-2-1 IP アドレスとサブネットマスクの関係について

IP アドレスはネットワーク部とホスト部で構成します。ネットワーク部は接続した機器群を指し、ホスト部はその中の機器を指します。サブネットマスクはネットワーク部とホスト部の区別に使用します。

IP address

ネットワーク部	ホスト部
---------	------

例：IP address 192.168.250.10

サブネットマスク 255.255.255.0

192.	168.	250.	10
------	------	------	----

255.	255.	255.	0
------	------	------	---

← ネットワーク部      ホスト部 →

↓ サブネットマスク=1 (2進数) がネットワーク部を示します。

11111111.	11111111.	11111111.	00000000
-----------	-----------	-----------	----------

## 7 Relationship between I/O data allocation and solenoid valves

The relationship between the solenoid valves and the allocation of I/O data to the serial transmission block varies according to the "Wiring specifications" specified in the order number of the manifold.

Wiring specifications, blank (packed wiring): Wired according to specifications of mounted valves.

-W (double wiring): All wiring is for double solenoids, regardless of the specifications of the mounted valves.

### If wiring specifications are "blank" (packed wiring)

The valves specified in the single solenoid specifications (\*1) when ordering are wired to solenoid A only, and are not wired to solenoid B because wiring is done according to specifications for the mounted valves.

This means that it cannot function as a double solenoid valve after it is delivered because no current flows to solenoid B, even if it is switched from a single solenoid valve to a double solenoid valve.

### When wiring specifications are "-W" (double wiring)

All wiring is for double solenoids.

Assigned in order from the left, regardless of the installation position

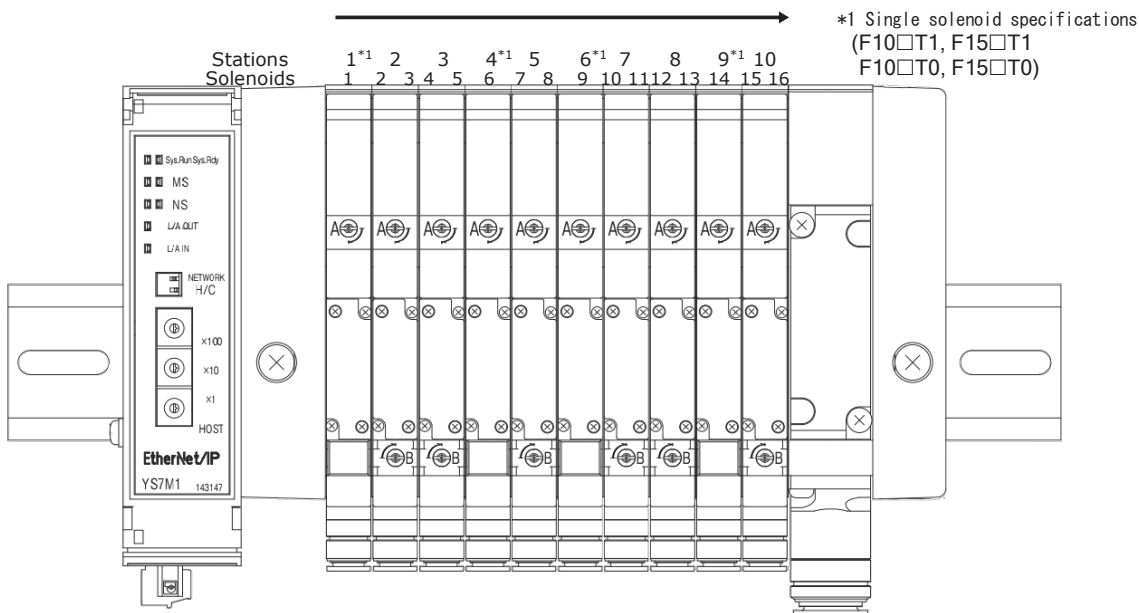

(example of above configuration) F10M10SJ-JR-M1

stn. 1	F10T1-A1	DC24V
stn. 2, 3	F10T2-A1	DC24V
stn. 4	F10T1-A1	DC24V
stn. 5	F10T2-A1	DC24V
stn. 6	F10T1-A1	DC24V
stn. 7, 8	F10T2-A1	DC24V
stn. 9	F10T1-A1	DC24V
stn. 10	F10T2-A1	DC24V

## Output supported by example configuration: YS7M1 (16 contacts)

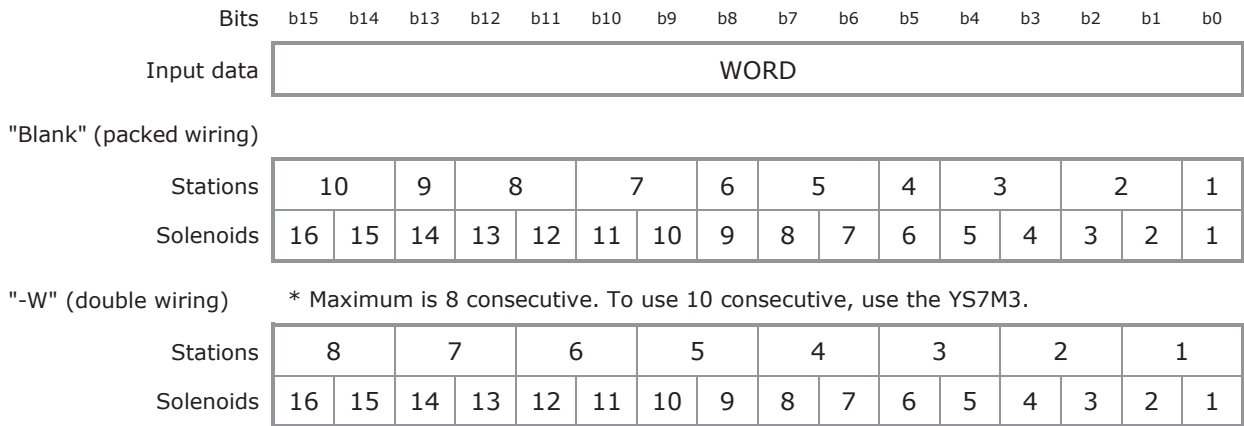

## 8 Network topology

The YS7Mn supports the following connection formats.

- Line format
- Star format
- Device level ring format

### 8-1 Line format

A line format network connects devices in a daisy chain format. Switching hubs are not needed, and the total length of the LAN cable can be reduced.

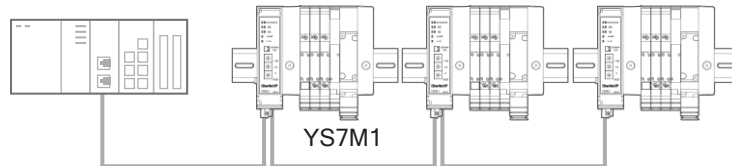

### 8-2 Star format

A star format network connects the various devices from switching hubs.

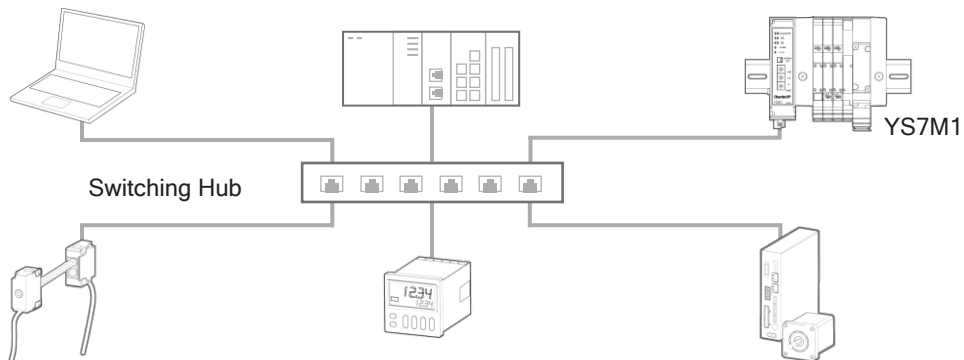

### 8-3 Device level ring format

A device level ring (hereafter DLR) format network is resilient to breakdowns. The connections are maintained by switching to line format communications if a line is cut or a device in the ring malfunctions. A control device known as a supervisor must be installed on the network.

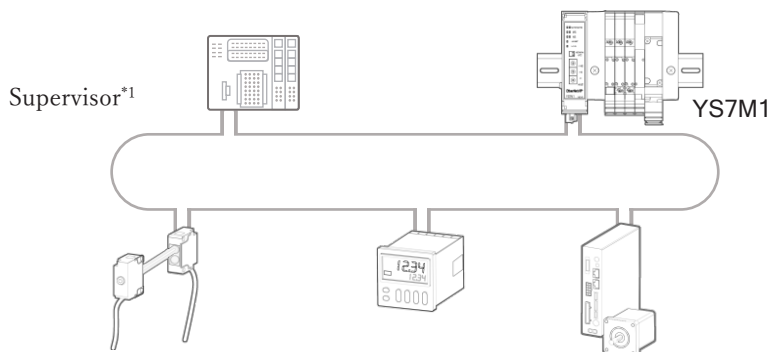

\*1 Rockwell CompactLogix, or similar

Basically, you must configure a DLR format network so that all the devices you connect support DLR.

Refer to the PLC manual for more details.

## 9 CIP class objects

Name of object	Class code	Description
Identity	01 hex	Provides information that identifies a product.
TCP/IP Interface	F5 hex	Provides the interface for the TCP/IP network.
Ethernet Link	F6 hex	Provides information for the IEEE802.3 communications interface.
Device Level Ring	47 hex	Provides information about the status of the device level ring.
Quality of Service	48 hex	Provides information about priority order of Ethernet frame.
Discrete Output Point	09 hex	Provides information about discrete outputs.
System Information	B0 hex	Provides information about products. (vendor expansion)

### 9-1 Identity (class code: 01 hex)

#### 9-1-1 Service code

Service code	Name
01 hex	Get_Attribute_All
05 hex	Reset
0E hex	Get_Attribute_Single

### 9-1-2 Attribute

Instance ID	Attribute	Access	NV	Name	Description	Data format
0	1	Get		Revision	Revision of identity object	UINT
0	2	Get		Max Instance	Maximum number of instances	UINT
1	1	Get		Vendor ID	Product vendor identification number	UINT
1	2	Get		Device Type	General type of device	UINT
1	3	Get		Product Code	Identification number for product	UINT
1	4	Get		Revision	Revision of product	Structure
				Major Revision	Major revisions Revision number for large changes that affect users.	USINT
				Minor Revision	Minor revisions Revision number for small changes that do not affect users.	USINT
1	5	Get		Status	State of communications with devices	WORD
1	6	Get		Serial Number	Number that identifies products of specific vendors	UDINT
1	7	Get		Product Name	Product name	SHORT_STRING
1	8	Get		State	State of device 0 = Nonexistent 1 = Device Self Testing 2 = Standby 3 = Operational 4 = Major Recoverable Fault 5 = Major Unrecoverable Fault 255 = Default Value	USINT

### 9-1-3 Reset service

Data	Description
0	Executes the same operation as power reset. This is the default operation if data is omitted.
1	Executes the same operation as power reset and returns settings to factory defaults.

#### List of settings that are initialized when data 1 is specified

Item	Initial value	Object	Attribute
How to Set IP Addresses	2 = DHCP	TCP/IP interface object	Configuration Method
IP address	0.0.0.0		Configuration Control
Subnet mask	0.0.0.0		
Default gateway	0.0.0.0 (disabled)		
TTL for multicast	1		

Method to specify multicast address	0 = Automatic allocation		Mcast Config
Multicast start address	0.0.0.0 (disabled)		
ACD enabled/disabled	1 = enabled		SelectAcid
ACD information	0		LastConflictDetected
Communication speed	0 = Auto-negotiate (automatic setting)	Ethernet link object	Interface Control
DSCP Scheduled	47	QoS object	DSCP Scheduled
DSCP Explicit	27		DSCP Explicit
Valve output count	0	Discrete output point object	Count
Accumulated operating time	0	System information object	Total power on time

## 9-2 TCP/IP interface (class code: F5 hex)

### 9-2-1 Service code

Service code	Name
01 hex	Get_Attribute_All
0E hex	Get_Attribute_Single
10 hex	Set_Attribute_Single

### 9-2-2 Attribute

Instance ID	Attribute	Access	NV	Name	Description	Data format
0	1	Get		Revision	Revision of TCP/IP interface object	UINT
0	2	Get		Max Instance	Maximum number of instances	UINT
1	1	Get		Status	State of TCP/IP network Bit0-3: Interface Configuration Status 1 = Established by BOOTP, DHCP, or NV 2 = Established by rotary switch Bit4-31: 0 fixed	DWORD

1	2	Get		Configuration Capability	Settings function Bit0: BOOTP Client Bit1: Reserved Bit2: DHCP Client Bit3: Reserved Bit4: Configuration Settable Bit5: Hardware Configurable Bit6: Reserved Bit7: ACD Capable Bit8-31: Reserved	DWORD
1	3	Get/Set	NV	Configuration Control	How to set IP addresses Bit0-3: Configuration Method 0 = Fixed IP address 1 = BOOTP 2 = DHCP Bit4-31: 0 fixed	DWORD
1	4	Get		Physical Link Object	Path to object linked on physical layer	Structure
				Path Size	Size of path fixed as 0002 hex	UINT
				Path	Logical segment that identifies object linked on physical layer 20 F6 24 01 hex fixed	EPATH
1	5	Get/Set	NV	Interface Configuration	Settings for TCP/IP network	Structure
				IP Address	IP address	UDINT
				Network Mask	Subnet mask	UDINT
				Gateway Address	Default gateway	UDINT
				Name Server	Primary name server	UDINT
				Name Server 2	Secondary name server	UDINT
				Domain Name	Name of domain	STRING
1	6	Get/Set	NV	Host Name	Name of host	STRING
1	8	Get/Set	NV	TTL Value	Time to live for multicast	USINT
1	9	Get/Set	NV	Mcast Config	Multicast address settings	Structure
				Alloc Control	Method to allocate multicast address	USINT
				Reserved	Reserved	USINT
				Num Mcast	Number of multicast addresses	UINT
				Mcast Start Addr	Multicast start address	UDINT
1	10	Get/Set	NV	SelectAcd	ACD enabled/disabled	BOOL
1	11	Get/Set	NV	LastConflictDetected	Most recently detected conflict information	Structure
				AcdActivity	State of ACD when conflict was detected	USINT
				RemoteMAC	Conflicting MAC address	ARRAY of 6 USINT
				ArpPdu	ARP message when conflict occurred	ARRAY of 28 USINT

**9-3 Ethernet Link (class code: F6 hex)**

## 9-3-1 Service code

Service code	Name
01 hex	Get_Attribute_All
0E hex	Get_Attribute_Single
10 hex	Set_Attribute_Single

## 9-3-2 Attribute

Instance ID	Attribute	Access	NV	Name	Description	Data format
0	1	Get		Revision	Revision of Ethernet link object	UINT
0	2	Get		Max Instance	Maximum number of instances	UINT
1-2	1	Get		Interface Speed	Speed of communications at IN port	UDINT
1-2	2	Get		Interface Flags	Status of IN port	DWORD
1-2	3	Get		Physical Address	MAC address	ARRAY of 6 USINT
1-2	4	Get		Interface Counters	Number of packets sent and received at interface	Structure
				In Octets	Number of packets received at interface	UDINT
				In Ucast Packets	Number of unicast packets received at interface	UDINT
				In NUCast Packets	Number of non-unicast packets received at interface	UDINT
				In Discards	Number of incoming packets that were discarded	UDINT
				In Errors	Number of packets that had errors (not counting the incoming discards)	UDINT
				In Unknown Protos	Number of packets with unknown protocols	UDINT
				Out Octets	Number of octets sent	UDINT
				Out Ucast Packets	Number of unicast packets sent	UDINT
				Out NUCast Packets	Number of non-unicast packets sent	UDINT
				Out Discards	Number of sent packets that were discarded	UDINT
				Out Errors	Number of packets that had errors	UDINT
1-2	5	Get		Media Counters	Ethernet media counter	Structure
				Alignment Errors	Number of received frames whose lengths were not octets	UDINT
				FCS Errors	Number of frames received that did not match FCS	UDINT
				Single Collisions	Number of sent frames for which one collision occurred	UDINT
				Multiple Collisions	Number of sent frames for which more than one collision occurred	UDINT
				SQE Test Errors	Number of SQE test error messages that were generated	UDINT
				Deferred Transmissions	Number of frames whose first transmission was delayed because the media was busy	UDINT

				Late Collisions	Number of collisions detected after 512 bit time slot	UDINT
				Excessive Collisions	Number of frames that failed to be sent due to too many collisions	UDINT
				MAC Transmit Errors	Number of frames that failed to be sent due to errors in MAC sublayer	UDINT
				Carrier Sense Errors	Number of errors or losses of carrier sense	UDINT
				Frame Too Long	Number of frames received that exceeded maximum allowable frame size	UDINT
				MAC Receive Errors	Number of frames that failed to be received because of errors in MAC sublayer	UDINT
1-2	6	Get/Set	NV	Interface Control	Control for interface	Structure
				Control Bits	Specify full duplex mode for auto negotiations	WORD
				Forced Interface Speed	Communication speed when full duplex mode is specified	UINT
1-2	7	Get	NV	Interface Type	Type of physical interface	USINT
1-2	8	Get		Interface State	State of interface	USINT
1-2	9	Get/Set	NV	Admin State	Whether interface is enabled or disabled	USINT
1-2	10	Get	NV	Interface Label	Name that identifies interface	SHORT_STRING

#### 9-4 Device Level Ring (class code: 47 hex)

##### 9-4-1 Service code

Service code	Name
0E hex	Get_Attribute_Single

##### 9-4-2 Attribute

Instance ID	Attribute	Access	NV	Name	Description	Data format
0	1	Get		Revision	Revision of device level ring object	UINT
0	2	Get		Max Instance	Maximum number of instances	UINT
1	1	Get		Network Topology	Format of connections in a network	USINT
1	2	Get		Network Status	Format of a network	USINT
1	10	Get		Active Supervisor Address	Address supervisor that is operating	Structure
				Supervisor IP Address	IP address of supervisor	UDINT
				Supervisor MAC Address	MAC address of supervisor	ARRAY of 6 USINT

## 9-5 Quality of Service (class code: 48 hex)

### 9-5-1 Service code

Service code	Name
0E hex	Get_Attribute_Single
10 hex	Set_Attribute_Single

### 9-5-2 Attribute

Instance ID	Attribute	Access	NV	Name	Description	Data format
0	1	Get		Revision	Revision of quality of service object	UINT
0	2	Get		Max Instance	Maximum number of instances	UINT
1	5	Get/Set	NV	DSCP Scheduled	Scheduled priority for CIP transport class 0/1 message	USINT
1	8	Get/Set	NV	DSCP Explicit	Priority for UCMM CIP transport class 2/3 and other messages	USINT

## 9-6 Discrete Output Point (class code: 09 hex)

### 9-6-1 Service code

Service code	Name
0E hex	Get_Attribute_Single
10 hex	Set_Attribute_Single

### 9-6-2 Attribute

Instance ID	Attribute	Access	NV	Name	Description	Data format
1-N *1	3	Get/Set		Value	Output value 0 = off, 1 = on	BOOL
1	5	Get		Fault Action	Operation when communication breakdown occurs Clear = 0, Hold = 1	BOOL
1-N *1	100	Get/Set	NV	Count	Number of outputs	UDINT

\*1 YS7M1 = 16, YS7M3 = 32

### CAUTION

Set the hold/clear switch to hold when a value of 3 is set for the attribute.



**9-7 System Information (class code: B0 hex)**

## 9-7-1 Service code

Service code	Name
0E hex	Get_Attribute_Single

## 9-7-2 Attribute

Instance ID	Attribute	Access	NV	Name	Description	Data format
1	100	Get		Power on time	Time from power on to operation	LTIME
1	101	Get		Power on days	(units are days)	UINT
1	102	Get		Power on hours	(units are hours)	UDINT
1	103	Get		Power on minutes	(units are minutes)	UDINT
1	104	Get		Power on seconds	(units are seconds)	UDINT
1	110	Get	NV	Total power on time	Accumulated operating time	LTIME
1	111	Get	NV	Total power on days	(units are days)	UINT
1	112	Get	NV	Total power on hours	(units are hours)	UDINT
1	113	Get	NV	Total power on minutes	(units are minutes)	UDINT
1	114	Get	NV	Total power on seconds	(units are seconds)	UDINT

## 10 Web page

### 10-1 How to use

You can check the internal status from the web page.

1. Open a browser.
2. Input the IP address of YS7Mn in the URL field.  
The web page opens.

IP address of YS7Mn

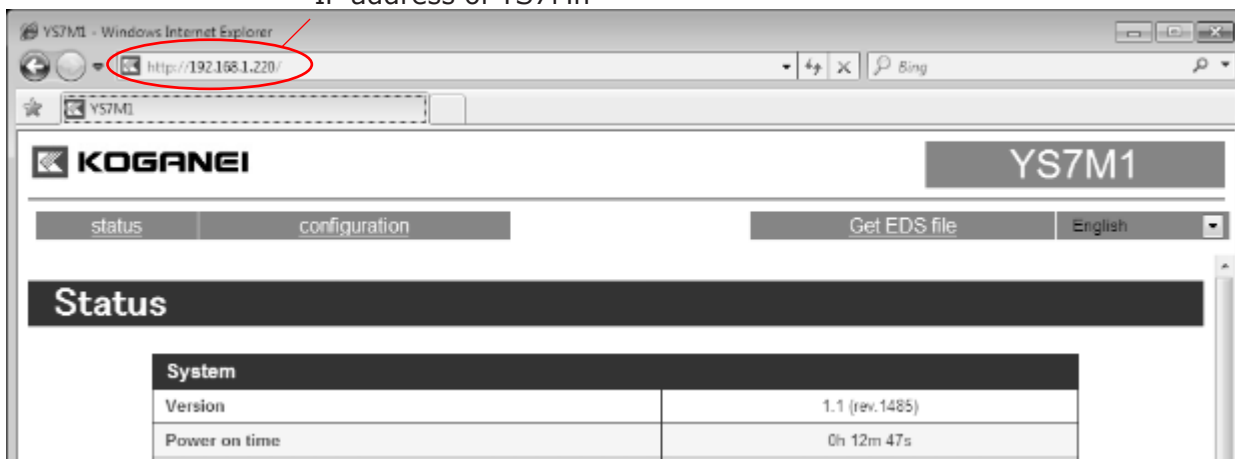

※ To check use Internet Explorer 7 or later, Firefox 9.0 or later, or Google Chrome 4.0 or later.

## 11 Specifications

### 11-1 General specifications

Item	YS7M1	YS7M3
Power supply voltage	DC24V ± 10%	
Power consumption	3 W or less (excluding solenoid valves)	
Operating temperature range	5 to 50 °C	
Operating humidity range	35 to 85% RH (non-condensation)	
Operating atmosphere	No corrosive gases and no excessive dust	
Vibration resistance	49.0m/s <sup>2</sup>	
Shock resistance	98.1m/s <sup>2</sup>	
Dielectric strength	1000 VAC for 1 minute (between all external terminals and the case)	
Noise resistance	IEC61000-4-4 compliant, level 3	
Insulation resistance	10 MΩ or more (between all external terminals and the case, using a 500 VDC insulation tester)	
Standard	CE marking compliant	

### 11-2 Communication specifications

Item	YS7M1	YS7M3
Vendor ID	429	
Output size	2 byte	4 byte
Number of ports	RJ45 × 2	
Physical layer	10BASE-T, 100BASE-TX	
CIP cyclic communications	Connection	Class 1, Exclusive Owner: 1
	RPI	1 ~ 1000 ms
CIP explicit message	Connection	Class 3, UCMM: 8
Communication speed	10, 100 Mbps, full duplex, half duplex, auto-negotiate	
MDI	MDI, MDI-X, Auto-MDIX	
IP address settings	Fixed, BOOTP, DHCP	
Switching functions	Supported	
ACD	Supported	
DLR	Supported	
Supported protocols	CIP, HTTP	
Port numbers	CIP: 44818, 2222 HTTP: 80	
EthterNet/IP	CT13 compliant	

- For other information, detailed specifications, and precautions, see the product catalog.
- For inquiries about the product, contact your nearest Koganei sales office or the Overseas Department noted below.



**KOGANEI CORPORATION**

KOGANEI CORPORATION OVERSEAS DEPARTMENT  
3-11-28, Midoricho, Koganei-shi, Tokyo, 184-8533, Japan  
TEL : +81-042-383-7271 FAX : +81-042-383-7276  
Website: <http://www.koganei.co.jp>

- The specifications or the appearance of this product are subject to change any time without prior notice.

1/25 KG ©KOGANEI CORP. PRINTED IN JAPAN