

KOGANEI

Actuators



Stroke Sensors

INDEX

RoHS directive compliant products

Features	860
Handling instructions and precautions	863
Specifications	867
Precautions	869
Diagram of inner circuits	869
Order codes	870
Dimensions	875

⚠ CAUTION Before use, be sure to read the safety precautions at the front of the general personal catalog.

Accurate length sensing

Stroke Sensors

Air cylinder stop position can be specified in 1/100 mm units.

In combination with a counter, workpiece acceptance/rejection can be performed and history management can be performed by importing data into PLC.

- Integrated actuator and accurate measurement function
- Compact, space saving measurement sensor head
- 0.0025 mm resolution, ± 0.015 mm accuracy (10mm [0.394 in] measurement)
- Supports mounting on actuators that are slide type with mini guide sliders ($\phi 4.5$ to $\phi 20$ [0.177 to 0.787]) and rod slider ($\phi 6$ to $\phi 25$ [0.236 to 0.984]).

Mini guide sliders



Variations

- Standard cylinders
- Cylinders with buffer
- Cylinders with end keep
- Cylinders with shock absorber
- Clean system compatible cylinders
- Stroke adjustment cylinder
- Side mount cylinders

Cylinder bore and stroke

Cylinder bore	Standard stroke												mm [in]		
	5	10	15	20	25	30	40	50	60	70	80	90	100	120	125
$\phi 4.5$ [0.177]	5	10	—	—	—	—	—	—	—	—	—	—	—	—	—
$\phi 6$ [0.236]	5	10	15	20	25	30	—	—	—	—	—	—	—	—	—
$\phi 8$ [0.315]	5	10	15	20	25	30	—	—	—	—	—	—	—	—	—
$\phi 10$ [0.394]	5	10	15	20	25	30	40	50	60	70	80	90	100	120	125
$\phi 12$ [0.472]	—	10	15	20	25	30	40	50	60	70	80	90	100	120	125
$\phi 16$ [0.630]	—	10	15	20	25	30	40	50	60	70	80	90	100	120	125
$\phi 20$ [0.787]	—	10	15	20	25	30	40	50	60	70	80	90	100	120	125

Rod slider



Variations

- Standard cylinders
 $\phi 6$ [0.236], $\phi 10$ [0.394], $\phi 16$ [0.630], $\phi 20$ [0.787], $\phi 25$ [0.984]
- Cylinders with shock absorber
 $\phi 10$ [0.394], $\phi 16$ [0.630], $\phi 20$ [0.787], $\phi 25$ [0.984]
- End keep cylinders
 $\phi 16$ [0.630], $\phi 20$ [0.787], $\phi 25$ [0.984]

Cylinder bore and stroke

Cylinder bore	Standard stroke					Maximum available stroke	mm [in]	
	10	20	30	40	50	70	100	120
6 [0.236]	10	20	30	40	50	70	100	120
10 [0.394]	10	20	30	40	50	60	80	120
16 [0.630]	10	20	30	40	50	60	80	150
20 [0.787]	10	20	30	40	50	60	80	150
25 [0.984]	10	20	30	40	50	60	80	150

Remark: Cylinder bore and stroke depend on the above variations.

Example of use

● Small area workpiece sorting

The dimensions of five workpieces can be measured in a small area, and defective workpieces are sorted out.

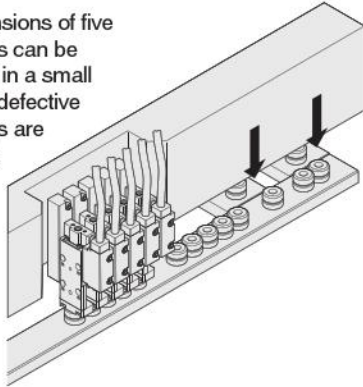

● Measurement of workpieces of greatly different dimensions

Workpieces of different dimensions (Example: 10 mm to 80 mm [0.394 in to 3.150 in]) can be measured and defective workpieces are sorted out.

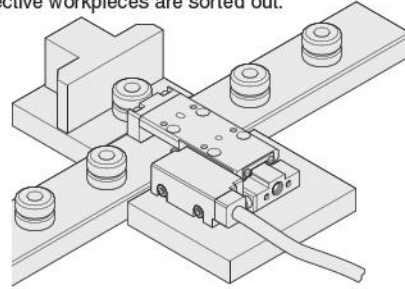

● Besides the above examples, these sliders are also perfect for lines that require press fitting checking, component inspection, and other precision measurements.

What is a stroke sensor?

The scale tape affixed to the actuator table can be measured using A phase/B phase difference output and 4X multiplication function with a photo-detection sensor, and the result can be displayed by the counter in 0.01 mm units, and there are four outputs. A humidity correction unit can be used for automatic correction of fluctuations in humidity.

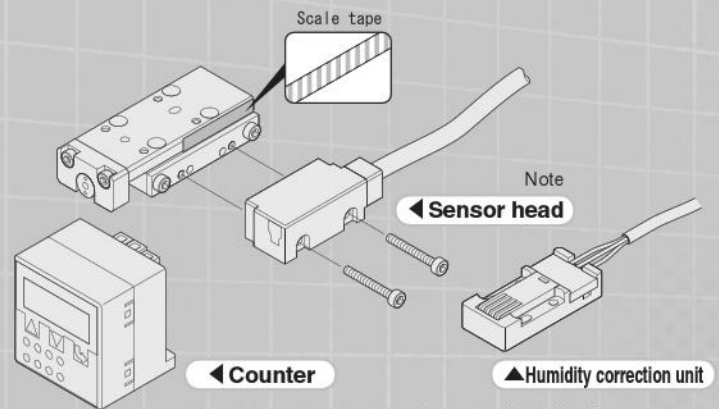

Note: Sensor heads cannot be ordered individually.

■ Optical encoder

Scale tape that consists of alternating reflective and non-reflective parts, which is affixed to the side of the cylinder table, is exposed to LED light. The reflected light is transformed electrically and partitioned to generate a 10 μm square wave.

■ Phase difference output

Optical encoder output is provided with a 90° phase difference, obtaining A phase and B phase output. As a result, an A phase Hi state rise and B phase Lo state relationship means that the table is moving forward, and the count is incremented.

When the table moves in reverse, A phase rises to a Hi state and B phase is in a Hi state, and the count is decremented.

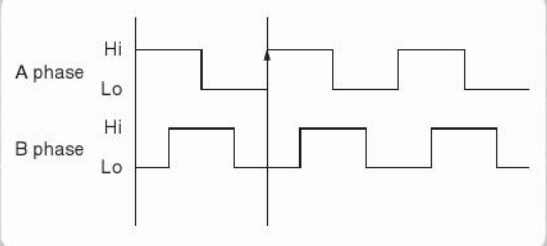

■ 4X multiplication function

By combination of the Hi state and Lo state of the A phase and B phase obtained by the 90° phase difference divides the square wave of one cycle by 4, obtaining 4-pulse output.

With the stroke sensor, a one cycle square wave is 10 μm , so one pulse is 2.5 μm and the number of pulses counted by the counter is multiplied by 2.5 μm to calculate the distance traveled.

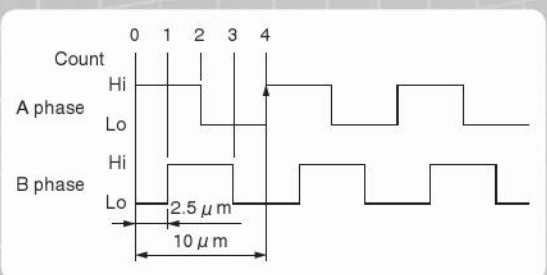

● For information about rod slider unit safety precautions, refer to the general catalog. Also refer to "Handling instructions and precautions" at the Koganei website.

Handling instructions and precautions



Mounting

Connection instructions for power supply connector

When the power cable (including the connecting cable) is delivered, the mini clamp wire mounting plug and mini clamp wire mounting socket are not yet connected. As a result, follow the instructions below to connect them. Moreover, if performing a reconnection for the purposes of length adjustment, use the instructions below for the connection.

- For the reconnection, always use the mounting plug or socket shown below.
Mini clamp wire mounting plug 4P Model: **FS1U-4M**
Mini clamp wire mounting socket 4P
Recommended Model: 37304-3101-000FL (Manufactured by 3M)
- Check that the cover of the mini clamp wire mounting plug (the part where lead wires are to be inserted) is protruding from the body of mini clamp wire mounting plug. It cannot be used if it's flat and placed at the same level against the body.



- Cut the connecting power cable to the required length.
Remove the outer sheath for 50 mm [1.969 in] from the tip of the cable, to expose the lead wires. At this time, do not remove the insulation from the lead wires.

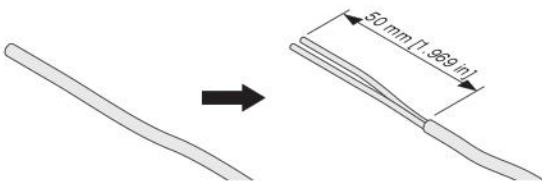

- Follow the instructions in the table to insert the lead wires into the hole in the cover of mini clamp wire mounting plug. Look through the top of the semi-transparent cover to check that the lead wires have been firmly inserted all the way to the back. (Insertion is about 9 mm [0.354 in].)
Use caution in making the connections, since switching on the power with mistakes in the connections will damage the sensor head and counter.

No. on the connector	Signal name	Color of lead wire
1	Counter power supply (+)	Brown
2	Counter power supply (0V)	Blue
3	NC	—
4	NC	—

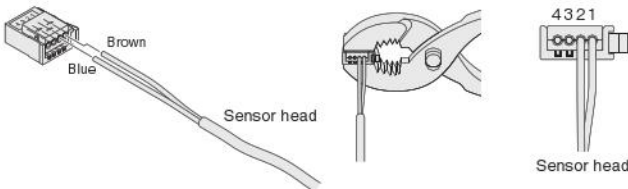

- Taking care to avoid letting the lead wires slip out from the mini clamp wire mounting plug, use pliers or some other hand tool to crimp the cover and mini clamp wire mounting plug body, and push the cover into the mini clamp wire mounting plug body. Limit the crimping force to 980.7 N [220.5 lbf]. When the cover is flat and placed at the same level against the mini clamp wire mounting plug body, the connection is complete.
- Use the same process for the mini clamp wire mounting socket.
- Check one more time that the wiring is correct.

Connection instructions for the sensor head connector

When the sensor head cable is delivered, the mini clamp wire mounting plug is not yet connected. As a result, follow the instructions below to connect it. Moreover, if performing a reconnection for the purposes of length adjustment, use the instructions below for the connection. If you want to extend the sensor head cable, follow the "Connection instructions for sensor head connecting connector" on p.10-p.11 to connect the male straight connector to the sensor head cable, and the female connecting connector to one end of the sensor head connecting cable.

- For the reconnection, always use the mounting plug shown below.
Mini clamp wire mounting plug 4P Model: **FS1U-4M**
- Check that the cover of the mini clamp wire mounting plug (the part where lead wires are to be inserted) is protruding from the body of mini clamp wire mounting plug. It cannot be used if it's flat and placed at the same level against the body.



- Cut the sensor head cable to match the required length.
Remove the outer sheath for 50 mm [1.969 in] from the tip of the cable, to expose the lead wires. At this time, do not remove the insulation from the lead wires. Take suitable measures to ground the shield wire.

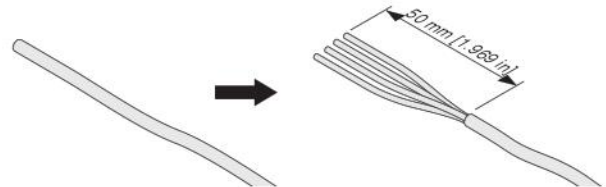

- Follow the instructions in the table to insert the lead wires into the hole in the cover of mini clamp wire mounting plug. Look through the top of the semi-transparent cover to check that the lead wires have been firmly inserted all the way to the back. (Insertion is about 9 mm [0.354 in].)
Use caution in making the connections, since switching on the power with mistakes in the connections will damage the sensor head and counter.

No. on the connector	Signal name	Color of lead wire
1	Sensor head power supply (+)	Brown
2	Sensor head power supply (0V)	Blue
3	Count output A phase	Black
4	Count output B phase	White

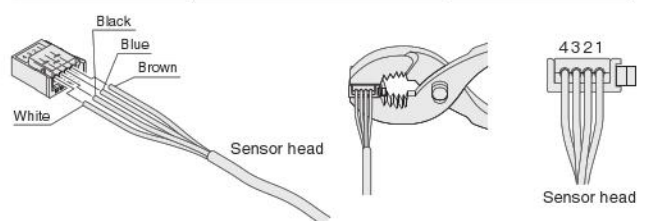

- Taking care to avoid letting the lead wires slip out from the mini clamp wire mounting plug, use pliers or some other hand tool to crimp the cover and mini clamp wire mounting plug body, and push the cover into the mini clamp wire mounting plug body. Limit the crimping force to 980.7 N [220.5 lbf]. When the cover is flat and placed at the same level against the mini clamp wire mounting plug body, the connection is complete.
- Check one more time that the wiring is correct.

Connection instructions for humidity correction unit connector

When the humidity correction unit cable and the humidity correction unit connecting cable are delivered, the mini clamp wire mounting plug and mini clamp wire mounting socket are not yet connected. As a result, follow the instructions below to connect them. Moreover, if performing a reconnection for the purposes of length adjustment, use the instructions below for the connection.

1. For the reconnection, always use the mounting plug or socket shown below.

Mini clamp wire mounting plug 3P Model: **FS1U-3M**

Mini clamp wire mounting socket 3P

Recommended Model: 37303-3101-000FL (Manufactured by 3M)

2. Check that the cover of the mini clamp wire mounting plug (the part where lead wires are to be inserted) is protruding from the body of mini clamp wire mounting plug. It cannot be used if it's flat and placed at the same level against the body.



3. Cut the humidity correction unit cable and the humidity correction unit connecting cable to match the required length.

Remove the outer sheath for 50 mm [1.969 in] from the tip of the cable, to expose the lead wires. At this time, do not remove the insulation from the lead wires.

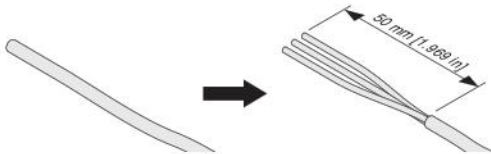

4. Follow the instructions in the table to insert the lead wires into the hole in the cover of mini clamp wire mounting plug. Look through the top of the semi-transparent cover to check that the lead wires have been firmly inserted all the way to the back. (Insertion is about 9 mm [0.354 in].)

Use caution in making the connections, since switching on the power with mistakes in the connections will damage the sensor head and counter.

No. on the connector	Signal name	Color of lead wire
1	Correction unit power supply (+)	Brown
2	Correction unit power supply (0V)	Blue
3	Correction unit output	Black

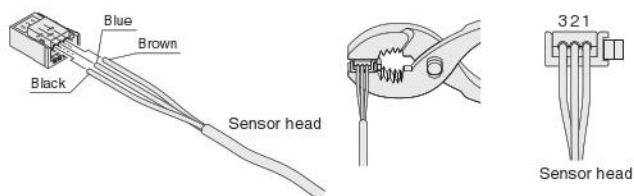

5. Taking care to avoid letting the lead wires slip out from the mini clamp wire mounting plug, use pliers or some other hand tool to crimp the cover and mini clamp wire mounting plug body, and push the cover into the mini clamp wire mounting plug body. Limit the crimping force to 980.7 N [220.5 lbf]. When the cover is flat and placed at the same level against the mini clamp wire mounting plug body, the connection is complete.
6. Use the same process for the mini clamp wire mounting socket.
7. Check one more time that the wiring is correct.

CAUTION

1. The humidity correction unit is used to correct scale tape expansion due to humidity.
Install it as near to the sensor head as possible.
2. Application in locations where extreme condensation is possible, or in locations where water or salt water can intrude can result in deterioration of the element.

Connection instructions for input/output/communication cable

Follow the instructions below to connect your device with the input/output/communication cable.

No. on the connector	Signal name	Color of lead wire
1	Input signal 1: reset	Red
2	NC	—
3	Output signal 1: Zone signal	White
4	Output signal 2: Start point signal	Green
5	Output signal 3: End point signal	Yellow
6	Output signal 4: Stop signal	Brown
7	RS232C : 0V	Black
8	RS232C : RXD	Blue
9	RS232C : TXD	Brown

Connection instructions for sensor head connecting connector

When the sensor head connecting cable is delivered, the male straight connector and the female connecting connector are not yet connected. As a result, follow the instructions below to connect them.

1. Pass the sensor head cable through the cord bushing and connector body, and solder it to the insulation unit contact.
Use caution in making the connections, since switching on the power with a mistake in the connection could cause damage to the sensor head and counter.
2. Solder the lead wire to the contact, and then use the crimping tool (Hirose Electric HR 10A-TC-02) or pliers to crimp the clamping part provided to the sensor head connecting cable. After crimping, the outer diameter should be approx. $\phi 5.3$ [0.209]. At this time, wrap the shield net wire into the sheath, use the clamping part to hold, and crimp in place.
3. Check one more time that the wiring is correct.

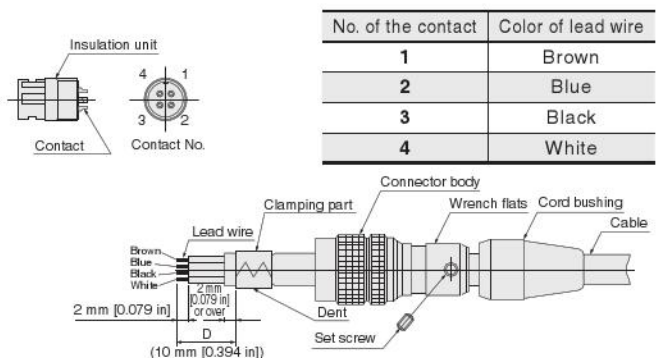

Handling instructions and precautions

- Screw the insulation unit thread into the connector body. Use a wrench to tighten to 1.5 N·m [13.277 in·lbf]. When tightening the connector body, first slacken D portion (10 mm [0.394 in]) to avoid applying a load on the soldered wiring, and then perform the tightening.
- Tighten the set screw so that the tip of the set screw touches the clamping part's either dent located in 2 places. Use a tightening torque of 0.3 N·m [2.655 in·lbf] for the mounting screw.
- Finally, cover the connector body with the cord bushing.
- Use the same process for the female connecting connector.

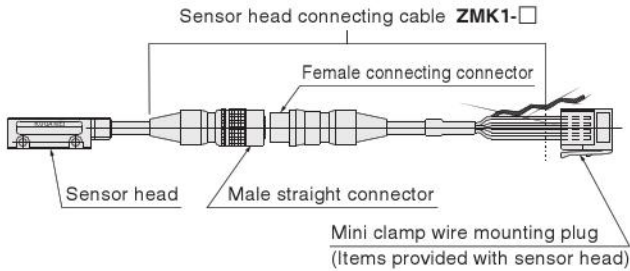

Installing and removing of power supply, sensor head, humidity correction unit, and input/output/ communication cables

When installing the power supply, sensor head, humidity correction units, and input/output/communication cables, align the lock lever position as shown in the diagram, and insert until it locks against the connector on the counter side.

To remove, push down on the lock lever and then pull out the mini clamp wire mounting plug. At this time, be careful to avoid applying excessive force to the lead wire.

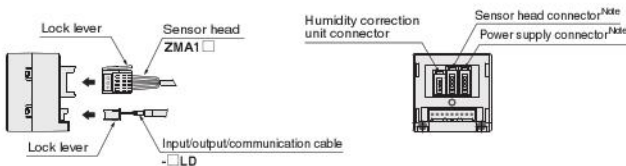

Note: Always be sure to check that the sensor head connector and power supply connector are not connected the wrong way.

Attaching the panel mounting parts and protective front cover

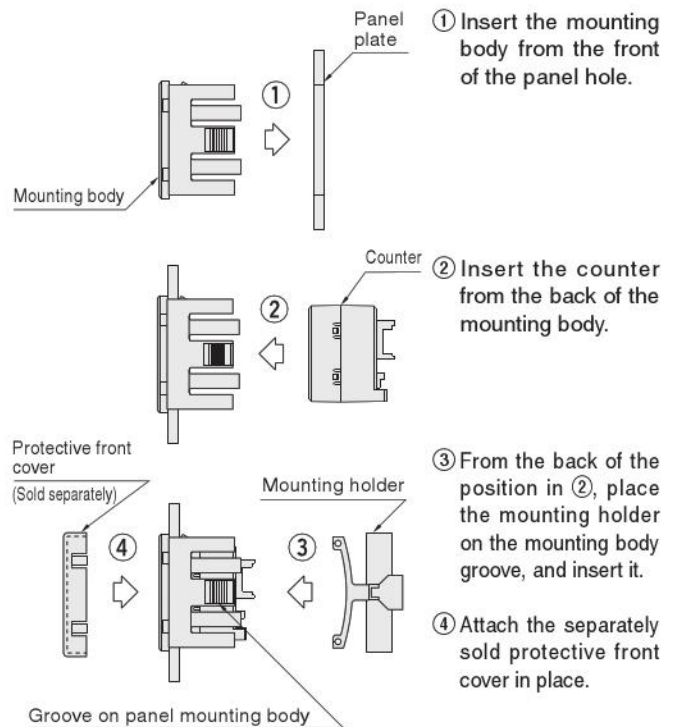

* For removal, follow the above procedure in reverse, using a screwdriver or other tool to remove the mounting holder.

Attaching the mounting bracket

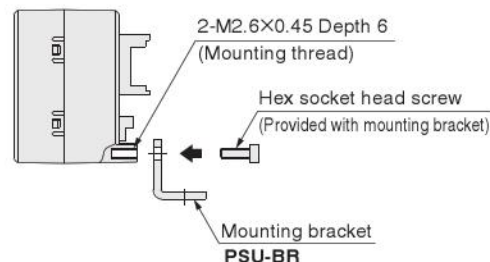

Use the hex socket head screws (M2.6×0.45 length 5 mm [0.197 in]) to mount the mounting bracket into the mounting holes on the back of the counter.

The tightening torque should be 0.32 N·m [2.832 in·lbf].

Maintenance

Using the stroke sensor in an environment where it is exposed to splashing coolant, dust, or other foreign matter can result in soiling of the sensor head sensor surface and/or scale, making correct sensing impossible. Periodic maintenance is recommended.

For information about maintenance procedures, refer to the instruction manual that comes with the product.

Major Parts and Functions

No.	Name	Description
①	LCD display	Displays distance, speed, time, and errors, etc.
②	Switch output indicator lamp (red)	Lights up when switch output is ON
③	UP key	Used when adjusting setting value upward
④	DOWN key	Used when adjusting setting value downward
⑤	Mode key	Used for all types of settings
⑥	Mode LED indicator (green)	Lights up when mode setting is performed

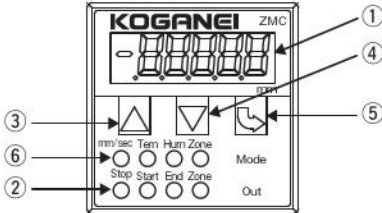

Output Mode

● Zone output

When the counter value is within the reference value \pm allowed value, the output is ON.

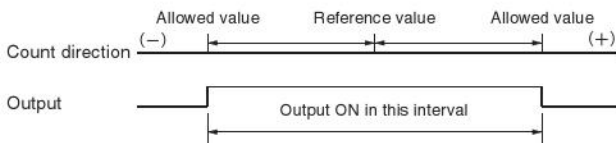

Note: Since the counter sampling interval is 2 ms, a maximum 2 ms delay occurs in output.
(If it passes from the (-) allowed value through the (+) allowed value in 2 ms or less, output may not occur.)



General precautions

Wiring

1. When using a power supply with a commercially available switching regulator, be sure to connect a frame ground (F.G.).
2. When using devices that generate noise (switching regulator, inverter motor, etc.) in the vicinity of the counter or mounted sensor head, be sure to connect a frame ground (F.G.) to the devices.
3. After completing wiring work, check to make sure that all connections are correct.

Other

1. Check fluctuations in the power source to confirm they do not exceed the ratings before turning on the power.
2. Avoid use during the transitional state (1 second) when the power is turned on.
3. Never use a needle or any other sharp pointed object to perform key operations.

For information about the cleaning procedure, setting procedure, error display, and communication with a computer, refer to the instruction manual (No. Y142993) that comes with the product.

Stroke Sensors



Specifications

● Sensor head

Model	ZMA1□			
Power supply voltage	24 VDC ±5%			
Consumption current	100mA MAX.			
Sensing method	Optical linear encoder			
Signal output	<p>A phase, B phase: Open collector output $I_c = 20\text{mA}$ (max.) Residual voltage: 0.3 V or less (at $I_c = 20\text{mA}$)</p>			
Output waveform	<p>AB phase open collector output phase</p>			
Pin assignments	24V Brown	GND Blue	A phase Black	B phase White
Minimum resolution	2.5 μm (for 4X multiplication)			
Accuracy	Measuring length: For L mm, $\pm 0.013 \pm (L \times 0.0002)$ mm Operating ambient temperature: 23°C [73°F]; Operating ambient humidity: 50% RH			
Maximum response frequency	600 kHz: (Maximum response speed: 1500 mm/s [59 in/sec])			
Maximum transmission distance	25 m [82.021 ft] (Using Koganei junction cable and Koganei counter)			
Mounting methods	Cylinder side mounting (factory assembled)			
Operation indicator lamp	Red encoder LED lights when power is turned on.			
Cable	Heat-resistant, oil-resistant vinyl sheath instrumentation cable $\phi 4.5$ [0.177] 0.15 mm ² 4-lead twisted pair shielded 3000 mm [118 in] With 4P connector			
Insulation resistance	100 MΩ or greater at 500 VDC megger			
Dielectric strength	500 VAC, 1 minute			
Shock resistance	30G, attenuation time: 11 ms			
Protective structure	None			
Vibration resistance	5G, 20 to 250Hz			
Operating temperature and humidity ranges	0 to 60°C [32 to 140°F] Less than 90% RH (Non-condensation, non-freezing)			
Storage temperature and humidity ranges	-20 to 60°C [-4 to 140°F] Less than 90% RH (Non-condensation, non-freezing)			
Material	Case: PBT			
Mass	100 g [3.5 oz] (Including cable)			
Junction cable (Option)	ZMK1-3L : 3 m [9.843 ft] ZMK1-5L : 5 m [16.404 ft]			

Reference: For rod slider main unit specifications, visit the Koganei website.

Counter

Model		ZMC1		
Power	Power supply voltage	24 VDC ±3%		
	Consumption current	100mA MAX. (not including supply power to sensor)		
	Sensor supply voltage	24 VDC		
Name	Value display	In distance display mode: Display of distance as ****.*** (mm) within effective measurement range		
		In speed display mode: Display of average speed of setting range. ***** (mm/s) (Mode indicator lamp: Green LED lit) (Refer to "Display accuracy 1", page 869)		
		In time display mode: Display of average duration. ***** (mm/s) (Mode indicator lamp: Green LED lit) (Refer to "Display accuracy 2", page 869)		
	Mode indicator lamp	Green LED lights when zone, temperature correction, humidity correction settings are enabled.		
	Operation indicator lamp	Red LED lights when each switch output is ON.		
Operation mode	Detection mode	Normal sensing mode		
	Setting mode	Zone signal output setting, temperature correction setting, humidity correction setting, display inversion setting		
	Display setting mode	Distance display, speed display, time display		
Input signal	Count input	Count input by sensor head connection		
	Reset input	LCD display reset 10 ms or greater 0.5 VDC or less		
Switch output	Output points: 4	Zone output OUT1	Output at the set threshold value interval	
		Start terminal output OUT2	Output when distance display is within ±"__0.25" and stop output is ON (equivalent to previous sensor cylinder start terminal side sensor)	
		Termination output OUT3	Output when distance display is at ±"__0.26" or greater (less) and stop output is ON	
		Stop output OUT4	Output when there is no displacement exceeding 0.25 within 0.1 s. (Refer to "Display accuracy 3", page 869)	
	Output method	NPN open collector output		
	Load voltage	30 VDC MAX.		
	Load current	50mA MAX.		
	Internal voltage drop	0.3V MAX. (at 5 mA)		
	Response time	100 ms or less (including cylinder stop output decision time)		
Settings	Main unit key setting	Refer to the instruction manual that comes with the product.		
	External communication settings	Refer to the instruction manual that comes with the product.		
Environmental resistance	Operating temperature range	0 to 50°C [32 to 122°F] (non-condensation, non-freezing)		
	Storage temperature range	-10 to 70°C [14 to 158°F] (non-condensation, non-freezing)		
	Noise resistance	EN61000-4-4 EFT/B level DATA: ±1 KV (Level 2)		
	Dielectric strength	500 VAC, 1 minute		
	Insulation resistance	100 MΩ or greater at 500 VDC megger		
	Vibration resistance	10 to 55 Hz, two hours in each direction (XYZ)		
	Shock resistance	294.2 m/s ² [30 G] (5 times each)		
General	Material	Case: PBT		
	Mass	60 g [2.116 oz] (excluding cable, mounting parts)		
Option	Cable (included)	Power cable	-3LE: 3 m [9.843 ft]	-5LE: 5 m [16.404 ft]
		Input, output, communication cable	-3LD: 3 m [9.843 ft]	-5LD: 5 m [16.404 ft]
	Junction cable (sold separately)	Power cable	ZMK2-3L: 3 m [9.843 ft]	ZMK2-5L: 5 m [16.404 ft]
		Humidity correction unit	ZMK3-3L: 3 m [9.843 ft]	ZMK3-5L: 5 m [16.404 ft]
	Mounting parts (included)	Mounting bracket	-B	
		Parts for panel mount	-P	
		Parts for panel mount (with protective front cover)	-P-C	
	Mounting parts (sold separately)	Mounting bracket	PSU-BR	
Parts for panel mount		PM100		
Protective front cover		KB100		

Humidity correction unit

Model		ZMH1	
Power supply voltage		5 VDC ±5%	
Consumption current		0.6mA MAX.	
Output voltage		10mV/%RH	
Pin assignments		5 V: Brown	GRD: Blue Analog output: Black
Cable		Oil resistant, flex resistant PCCV φ 2.6 [0.102] 0.15 mm ² 3-lead 3000 mm [118 in] With 3P connector	
Nominal accuracy		±5%	
Response time		1 min (90% elapsed time when 30% RH↔85% RH is 100)	
Operating temperature range		0 to 50°C [32 to 122°F] (non-condensation, non-freezing)	
Storage temperature range		-20 to 60°C [-4 to 140°F] (non-condensation, non-freezing)	
Vibration resistance		5 to 55 Hz, Amplitude: 2 mm [0.079 in], two hours in each direction (XYZ)	
Shock resistance		980 m/s ² [100 G] 6 ms Three times in each direction (XYZ)	
Material		Case: POM	
Mass		70 g [2.469 oz] (Including cable)	

Precautions

● Mounting

1. The sensor is not equipped with a protective structure. It is not suitable for use in locations subjected to large amounts of dust, or in locations where it is exposed to oil droplets, coolant, etc. For use in such locations, protect the sensor with a cover, etc.
2. An optical linear encoder is employed. Proper sensing will not be possible if a light source of 750 lux or greater is shining directly onto the sensor. 750 lux creates an environment suitable for general production process visual work (JIS Z 9110).
3. Do not pull on sensor cables with strong force.

● Wiring

1. Sensors ship connector free, with connectors included. Wiring should be done by someone who understands correct connection procedures, taking care not to make any connection errors.
2. Be sure to ground the shielded cable during use.
3. When using devices that generate noise (switching regulator, inverter motor, etc.) in the vicinity of the installed sensor, be sure to connect a frame ground (F.G.) to the devices.
4. To avoid miscounting due to noise, separate the sensor cable from other power lines and AC type valves.
5. After completing wiring work, check to make sure that all connections are correct.
6. Before turning on power, connect all connectors.
7. Check fluctuations in the power source to confirm they do not exceed the ratings before turning on the power.
8. Avoid use during the transitional state (1 second) when the power is turned on.
9. When extending cables, be sure to use Koganei junction cables to prevent miscounting due to noise.

● Receive circuit

1. When using a commercially available counter or other device, take care concerning the response frequency. Counting will not be possible if the cylinder speed is faster than the counter response frequency. A Koganei counter response frequency of 600 kHz supports a cylinder speed of 1500 m/s [59.055 in/sec] (including jumping and bouncing).
2. If a Koganei counter is not being used, output signal noise should be considered and a filter and other measures should be provided in the receive circuit.

● Sensing accuracy

1. Total accuracy after devices are mounted depends on the mounting condition and environment, so devices should be calibrated by you.
2. Sensor scale tape can expand and contract due to changes in temperature and humidity. Use the information below as guidelines for expansion/contraction values, and add expansion/contraction values in accordance with temperature and humidity.
 - 1) Relative to a standard temperature of 23°C [73.4°F], each rise of 10°C [50°F] causes elongation of 0.0018 mm (per 10 mm [0.394 in]), which means that the measured value should be shortened by approximately 0.0018 mm (per 10 mm [0.394 in]).
 - 2) Relative to a standard humidity of 50% RH, each rise of 10% RH causes elongation of 0.0012 mm (per 10 mm [0.394 in]), which means that the measured value should be shortened by approximately 0.0012 mm (per 10 mm [0.394 in]).

* The Koganei dedicated counter **ZMC1** corrects values using temperature input, while the separate humidity correction unit **ZMH1** automatically corrects for humidity.
3. When a cylinder's internal stopper is being used as the reference point, deformation of the bumper inside the cylinder can cause the reference point to change. If this happens, use a stroke adjustment cylinder with metal stopper, or provide an external stopper. Also note that a stopper becomes deformed with wear, so periodic maintenance is recommended.

● Display accuracy

1. In speed display mode, the average speed of the speed measurement range specified by you is displayed subject to the conditions described below. When the duration of the setting interval is 0.05 seconds or greater, the displayed time will have an error, relative to the actual time, within ±5%, within ±1 digit.
2. In time display mode, the duration of the speed measurement range specified by you is displayed, but sampling time within the counter (2 ms) will have a display error.
3. Stop output (stop decision) is output if there is no displacement exceeding 0.25 mm [0.01 in] within 0.1 seconds, so it is also output even when there is cylinder operation within 2.5 mm/s [0.098 in/sec]. However, distance measurement is performed.

Internal Circuit

● Stroke sensor counter block diagram

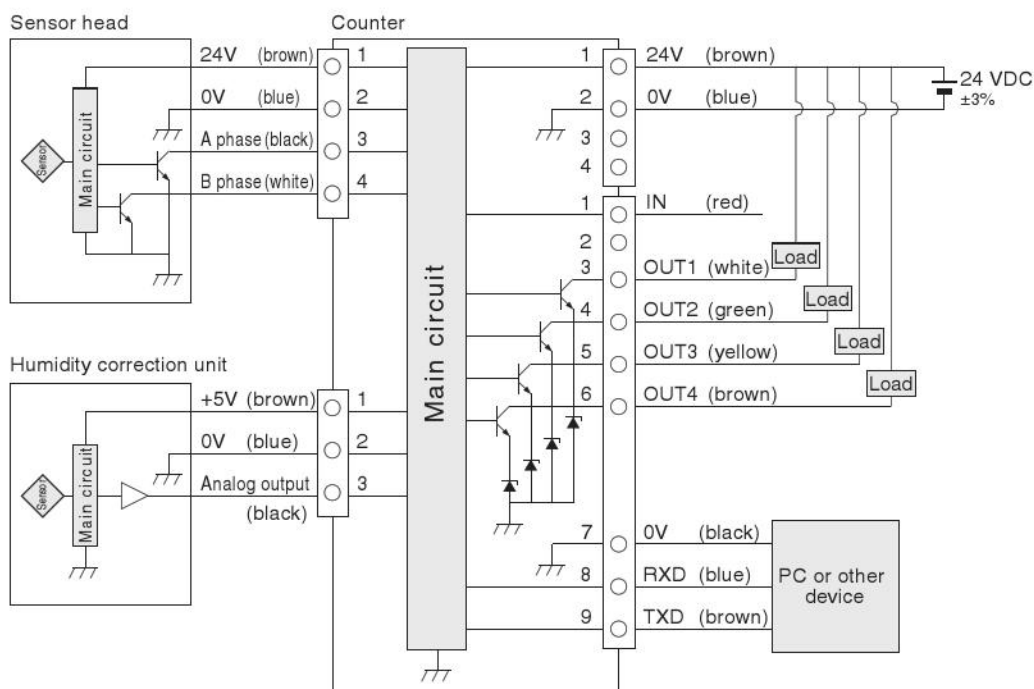

Order codes (Stroke sensor compatible mini guide slider)

● $\phi 4.5$ to 8 [0.177 to 0.315]

Important! For the products below, orders for just a sensor head or without a sensor head are not allowed.

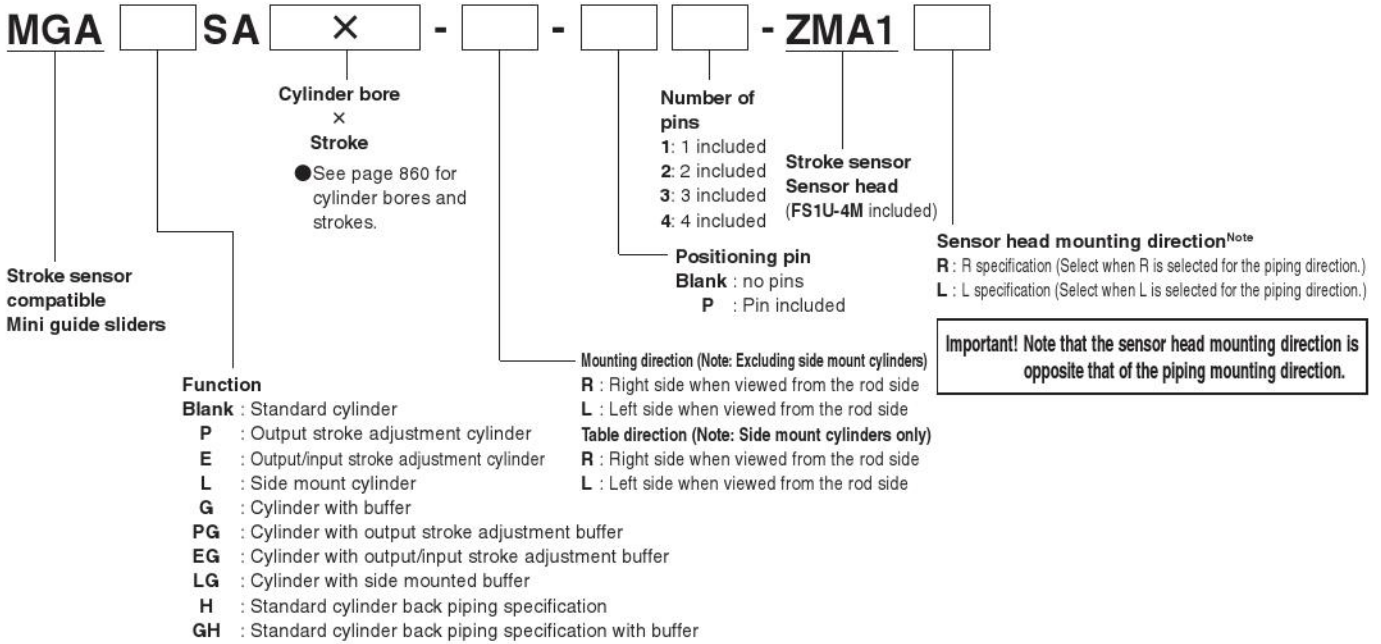

● $\phi 10$ [0.394]

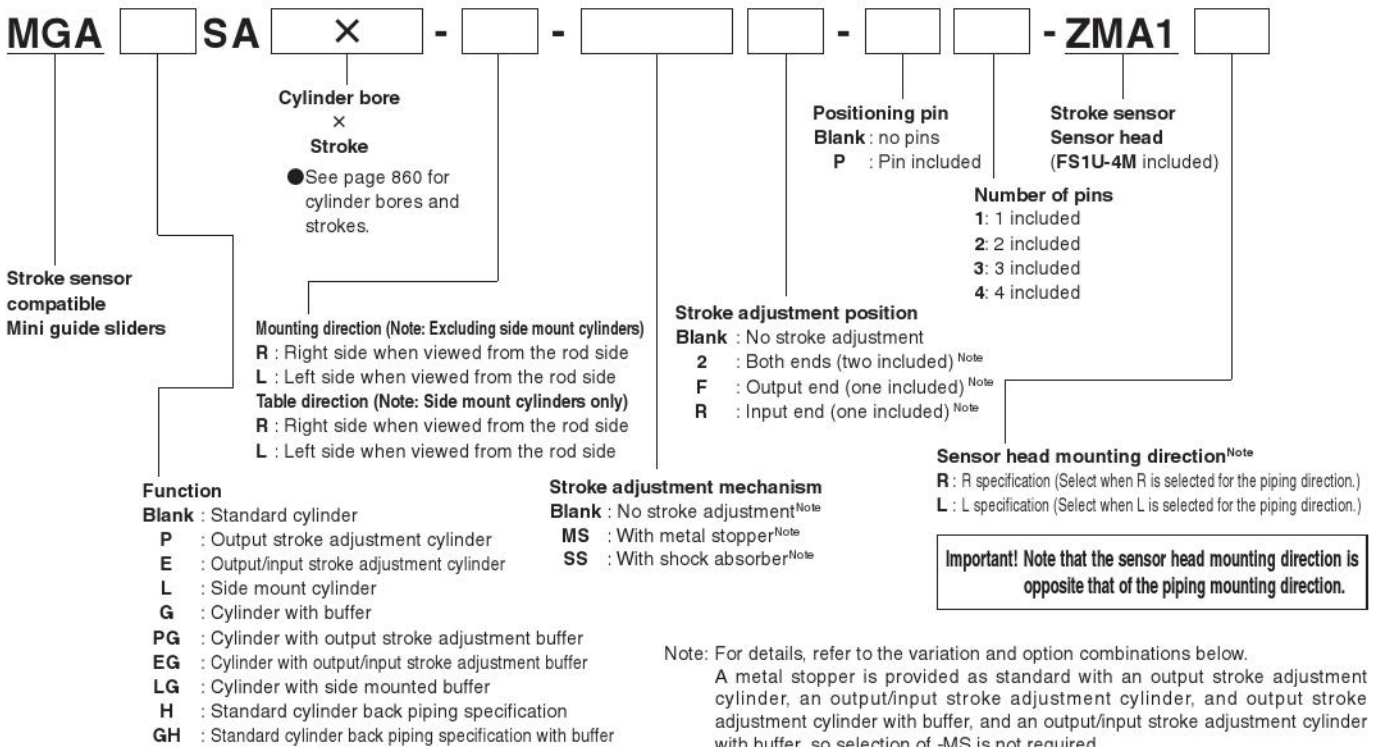

● Stroke sensor compatible mini guide slider $\phi 10$ [0.394] variation and option combinations

Model	Type	Metal stopper			Shock absorber		
		Output end -MSF	Input end -MSR	Both ends -MS2	Output end -SSF	Input end -SSR	Both ends -SS2
MGASA10	Standard	●	●	●	●	●	●
MGAPSA10	Output stroke adjustment	—	—	—	●	—	—
MGAESA10	Output/input stroke adjustment	—	—	—	●	●	●
MGALSA10	Side mounted	—	—	—	—	—	—
MGAGSA10	With buffer	—	●	—	—	●	—
MGAPGSA10	With output side stroke adjustment buffer	—	—	—	—	—	—
MGAEGSA10	With output/input side stroke adjustment buffer	—	—	—	—	●	—
MGALGSA10	With side-mounted buffer	—	—	—	—	—	—
MGAHSA10	Back side piping specification	●	—	—	●	—	—
MGAGHSA10	Back side piping specification with buffer	—	—	—	—	—	—

Order codes (Stroke sensor compatible mini guide slider)

● ϕ 12 to 20 [0.472 to 0.394]

Important! For the products below, orders for just a sensor head or without a sensor head are not allowed.

MGA **SA** × - - - - - **ZMA1**

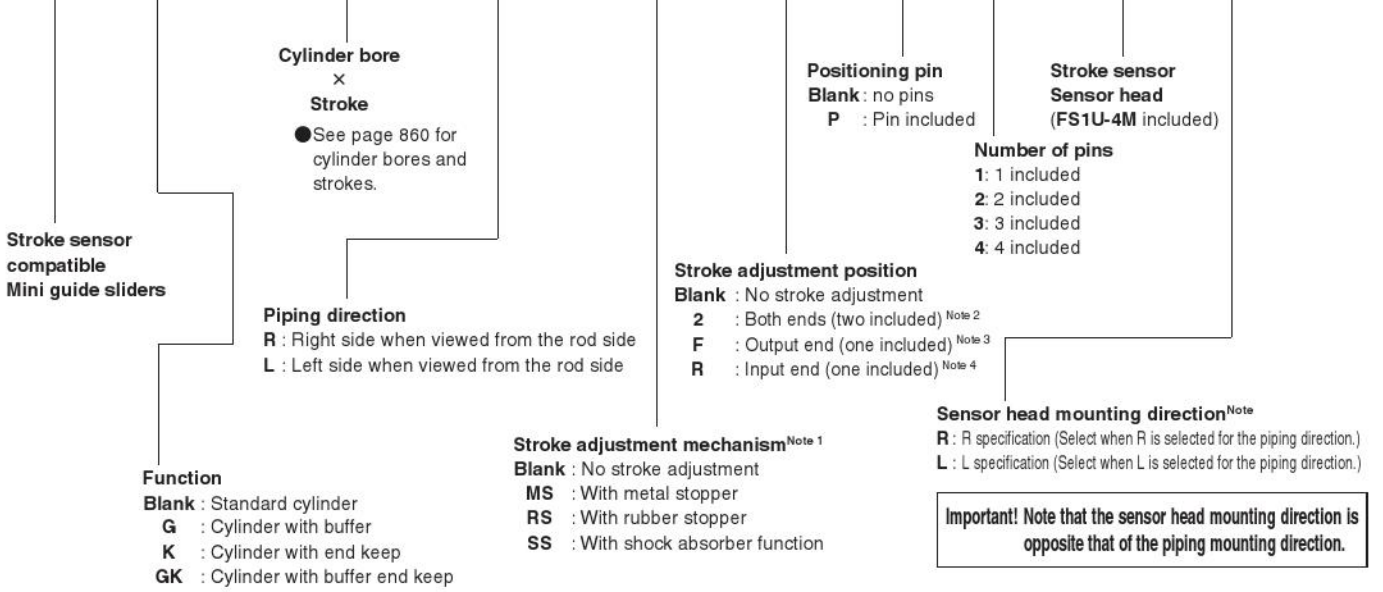

Note 1: Without buffer end keep (GK).
 Note 2: With buffer (G), without end keep (K).
 Note 3: Without buffer (G).
 Note 4: Without end keep (K).

● Stroke sensor compatible mini guide slider ϕ 12 [0.472], 16 [0.630], 20 [0.787] variation and option combinations

Model	Type	Metal stopper			Rubber stopper			Shock absorber		
		Output end -MSF	Input end -MSR	Both ends -MS2	Output end -RSF	Input end -RSR	Both ends -RS2	Output end -SSF	Input end -SSR	Both ends -SS2
MGASA12•16•20	Standard	●	●	●	●	●	●	●	●	●
MGAPSA12•16•20	Output stroke adjustment	—	—	—	●	—	—	●	—	—
MGAESA12•16•20	Output/input stroke adjustment	—	—	—	●	●	●	●	●	●
MGAGSA12•16•20	With buffer	—	●	—	—	●	—	—	●	—
MGAPGSA12•16•20	With output side stroke adjustment buffer	—	—	—	—	—	—	—	—	—
MGAEGSA12•16•20	With output/input side stroke adjustment buffer	—	—	—	—	●	—	—	●	—
MGAKSA12•16•20	With end keep	●	—	—	●	—	—	●	—	—
MGAGKSA12•16•20	With buffer end keep	—	—	—	—	—	—	—	—	—
MGAHSA12•16•20	Back side piping specification	●	—	—	●	—	—	●	—	—
MGAGHSA12•16•20	Back side piping specification with buffer	—	—	—	—	—	—	—	—	—

■ Mini guide slider main unit additional parts

● For details, refer to the catalog.

● $\phi 4.5$ to 8 [0.177 to 0.315]

Important! For the products below, orders for just a sensor head or without a sensor head are not allowed.

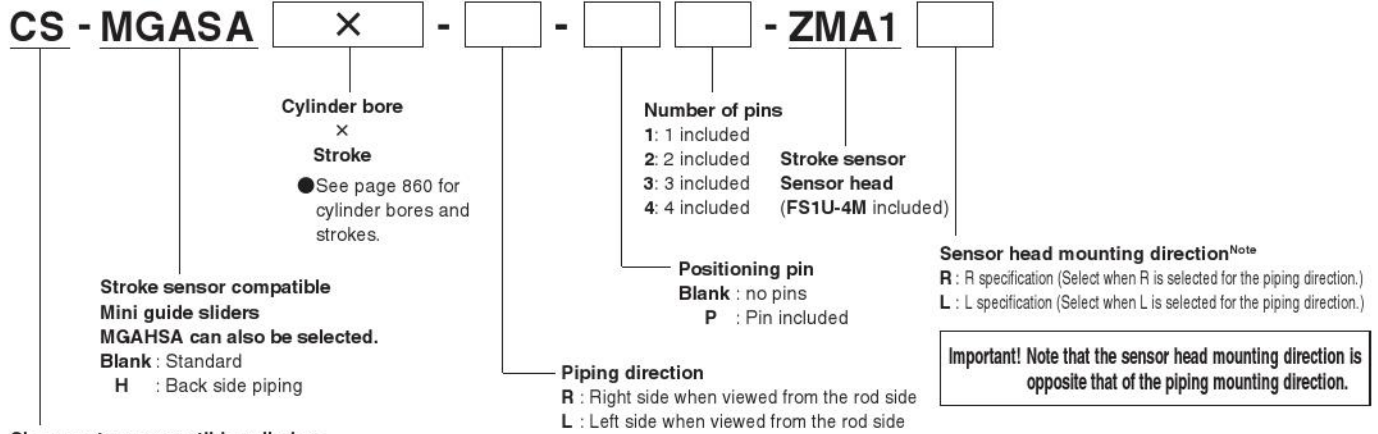

● $\phi 10$ to 20 [0.394 to 0.787]

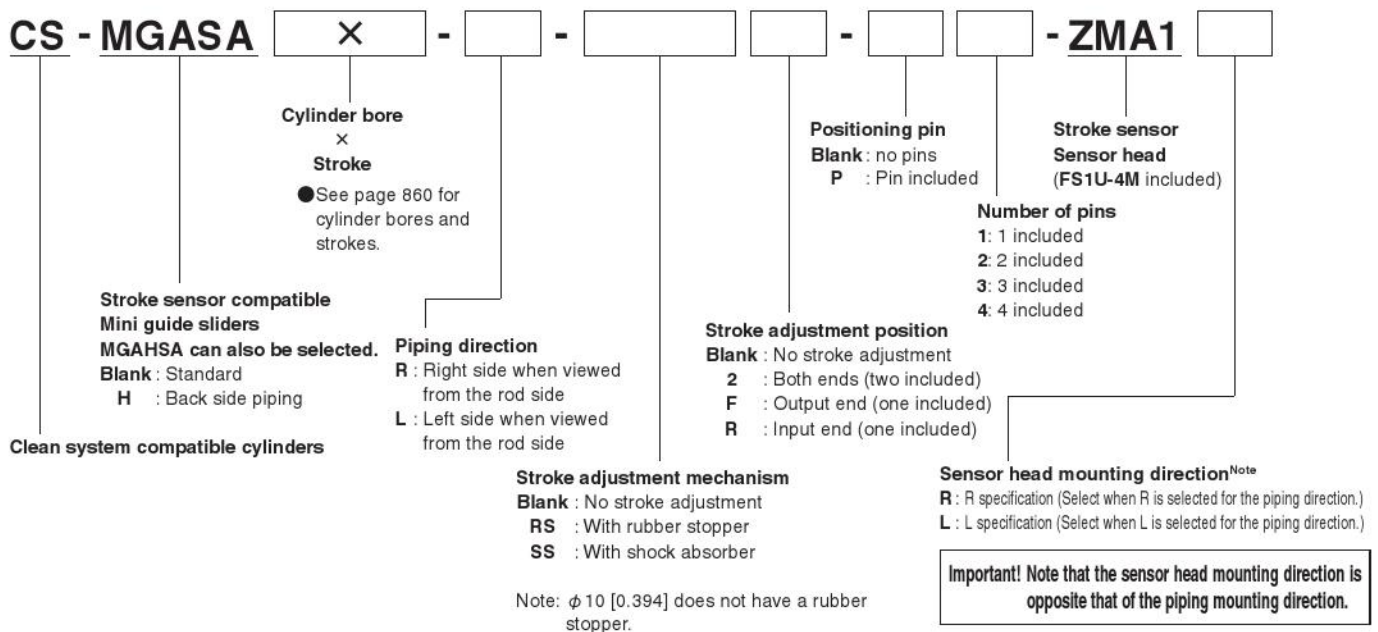

● Stroke sensor compatible mini guide slider $\phi 10$ [0.394], 12 [0.472], 16 [0.63], 20 [0.787] variation and option combinations

Model	Type	Rubber stopper			Shock absorber		
		Output end -RSF	Input end -RSR	Both ends -RS2	Output end -SSF	Input end -SSR	Both ends -SS2
CS-MGASA10	Clean system compatible	—	—	—	●	●	●
CS-MGAHSA10	Clean, back side piping	—	—	—	●	—	—
CS-MGASA12•16•20	Clean system compatible	●	●	●	●	●	●
CS-MGAHSA12•16•20	Clean, back side piping	●	—	—	●	—	—

■ Mini guide slider main unit additional parts

● For details, refer to the catalog.

Order codes (Stroke sensor compatible rod slider)

● Standard cylinders

Important! For the products below, orders for just a sensor head or without a sensor head are not allowed.

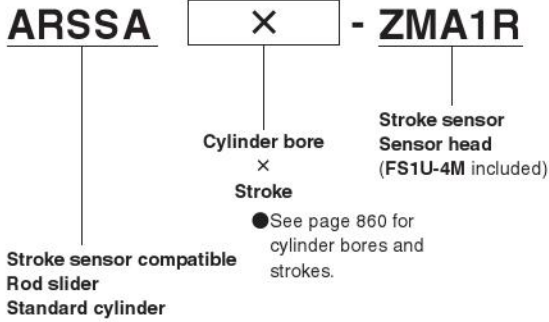

● Cylinder with shock absorber

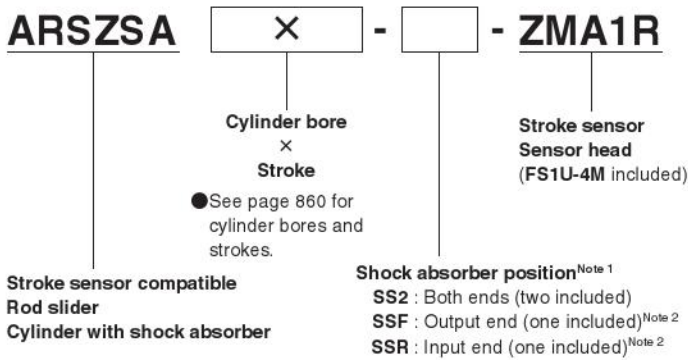

Note 1: Shock absorber and end keep cylinder cannot be used together.

Note 2: When one shock absorber (**SSF** or **SSR**) is included, add-on installation of the opposite side is not possible.

● End keep cylinders

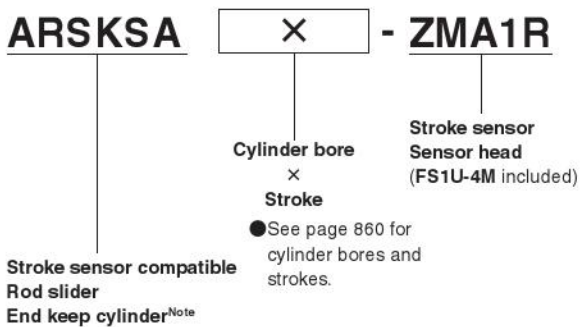

Note: The end keep position is head side keep only.

■ Rod slider main unit additional parts

● For details, refer to the rod slider page.

Order codes (counter, humidity correction unit)

● Counter

ZMC1 - [] - [] - [] - []

(FS1U-4M included)

Power cable (included)

Blank : None
 3LE : 3000 mm [118 in]
 5LE : 5000 mm [197 in]

Input, output, communication cable

Blank : None
 3LD : 3000 mm [118 in]
 5LD : 5000 mm [197 in]

Protective front cover ^{Note}

Blank : No protective front cover
 C : With protective front cover

Mounting parts

Blank : None
 B : With mounting bracket
 P : With panel mount parts

Note: Protective front cover can be selected only if panel mount parts are selected. The protective front cover alone cannot be mounted on the counter.



● Humidity correction unit

ZMH1

(FS1U-3M included)

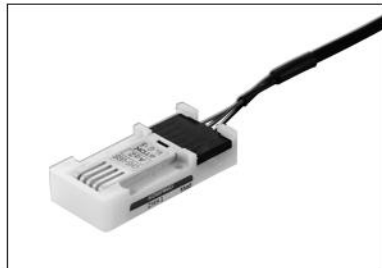

■ Additional parts (sold separately)

Sensor head junction cable ^{Note}

● ZMK1 - []

Cable length
 3L: 3000 mm [118 in]
 5L: 5000 mm [197 in]



Counter power supply junction cable ^{Note}

● ZMK2 - []

Cable length
 3L: 3000 mm [118 in]
 5L: 5000 mm [197 in]



Humidity correction unit junction cable ^{Note}

● ZMK3 - []

Cable length
 3L: 3000 mm [118 in]
 5L: 5000 mm [197 in]



Counter mounting bracket

● PSU-BR



Parts for counter panel mount

● PM100



Counter protective front cover

● KB100



Mini clamp wire mount plug
 (For humidity correction unit)

● FS1U-3M



Mini clamp wire mount plug
 (For sensor head, counter power supply)

● FS1U-4M



Note: Each junction cable is delivered unconnected. Connect them following the instructions on pages 863 and 864.

Dimensions mm [in] Stroke sensor compatible mini guide slider

Important! For information about mini guide slider unit dimensions, refer to the general catalog.

● -ZMA1R (Sensor head mounting direction R)

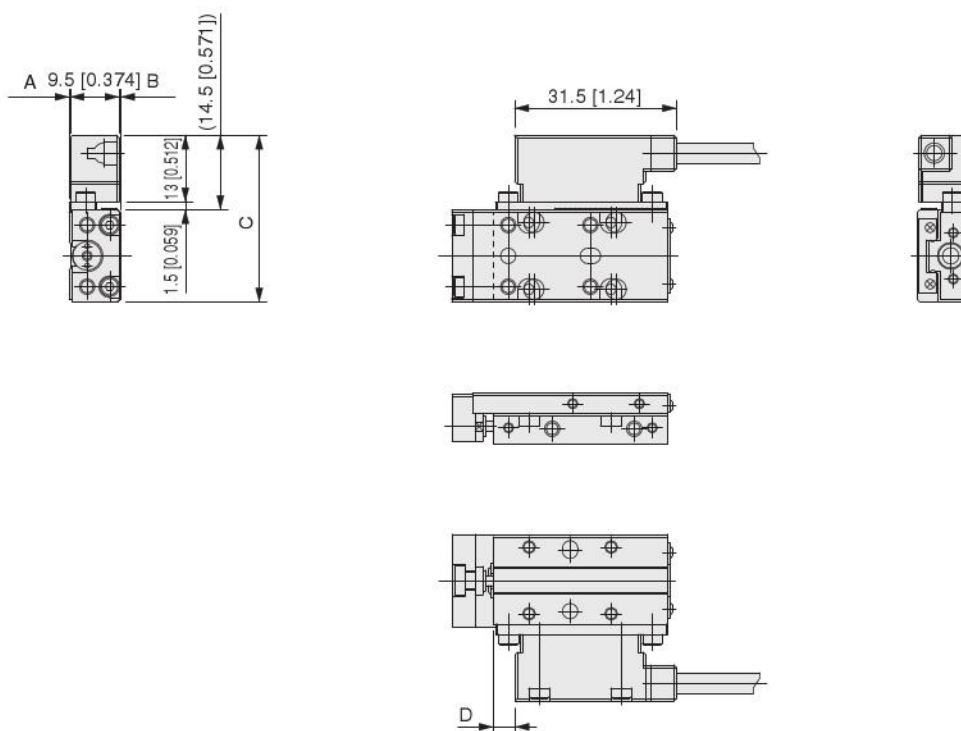

● -ZMA1L (Sensor head mounting direction L)

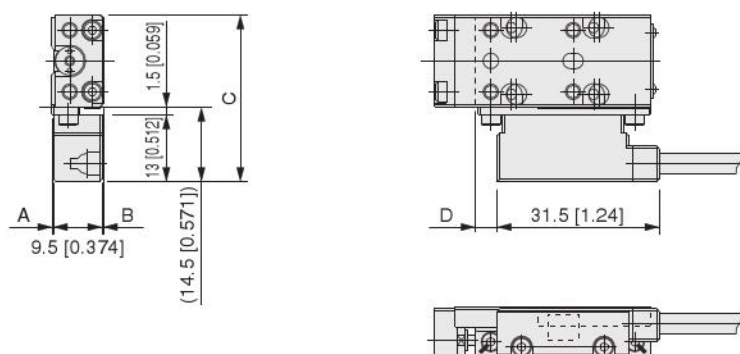

Cylinder bore / Code	A	B	C	D
4.5 [0.177]	0.2 [0.008]	(0.3 [0.012])	32.5 [1.280]	4.25 [0.167]
6 [0.236]	2.1 [0.083]	(0.4 [0.016])	34.5 [1.358]	4.25 [0.167]
8 [0.315]	3.2 [0.126]	(1.3 [0.051])	38.5 [1.516]	4.25 [0.167]
10 [0.394]	5.2 [0.205]	(1.3 [0.051])	40.5 [1.594]	4.25 [0.167]
12 [0.472]	5.2 [0.205]	(3.3 [0.13])	48.5 [1.909]	0.25 [0.01]
16 [0.630]	8.7 [0.343]	(4.8 [0.189])	54.5 [2.146]	2.25 [0.089] ^{Note 1}
20 [0.787]	12.2 [0.480]	(6.3 [0.248])	61.5 [2.421]	6.75 [0.266] ^{Note 2}

Note 1: D = 22.25 [0.876] in the case of stroke 90 [3.543] or greater.
 Note 2: D = 26.75 [1.053] in the case of stroke 90 [3.543] or greater.

Dimensions mm [in] Stroke sensor compatible rod slider

Important: For rod slider unit dimensions, refer to the **CD-ROM or Koganei website**.

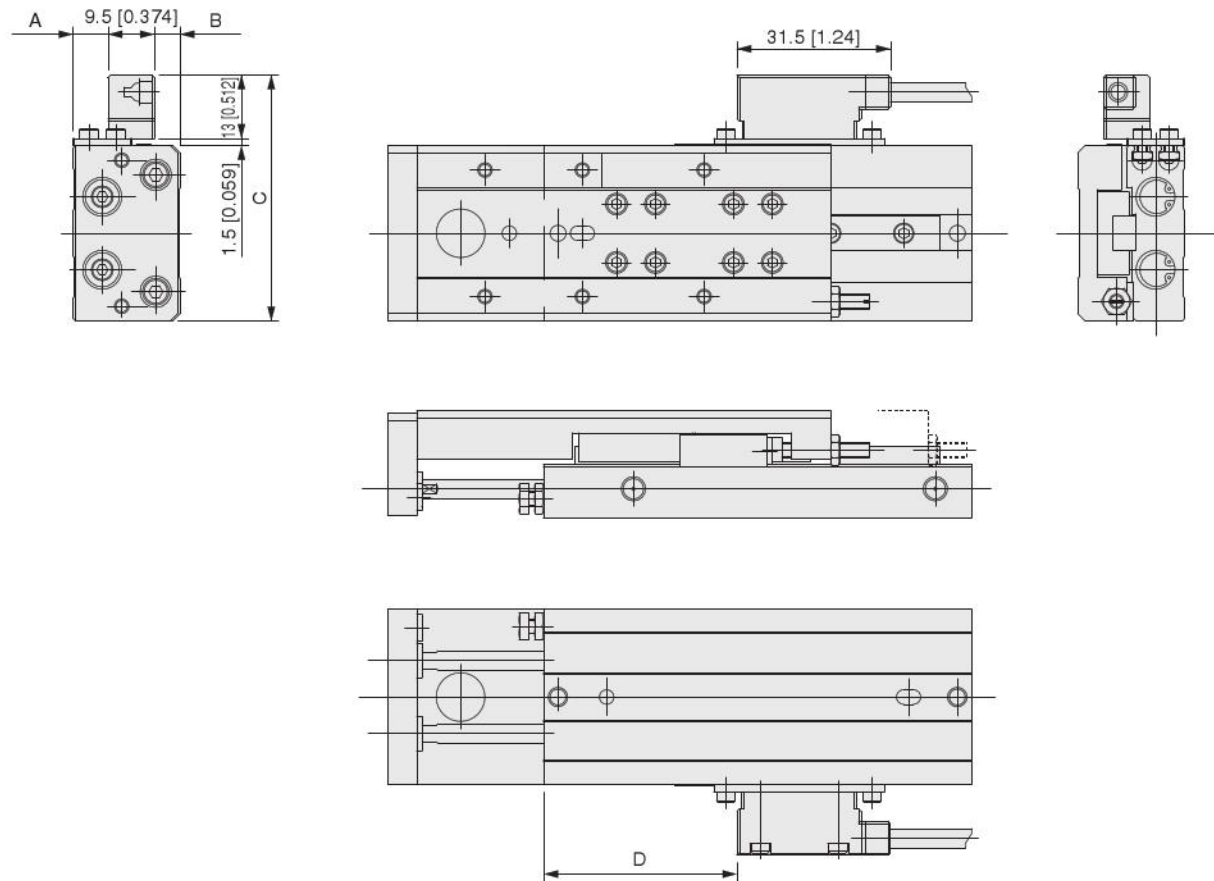

Cylinder bore	Code	A	B	C	D
6	[0.236]	7.2 [0.283]	5.3 [0.209]	50.5 [1.988]	39.75 [1.565]
10	[0.394]	12.7 [0.500]	8.8 [0.346]	65.5 [2.579]	46.75 [1.841]
16	[0.630]	17.2 [0.677]	11.3 [0.445]	75.5 [2.972]	46.75 [1.841]
20	[0.787]	22.2 [0.874]	15.3 [0.602]	86.5 [3.406]	56.75 [2.234]
25	[0.984]	29.7 [1.169]	17.8 [0.701]	104.5 [4.1]	61.75 [2.431]

●ZMC1 Counter

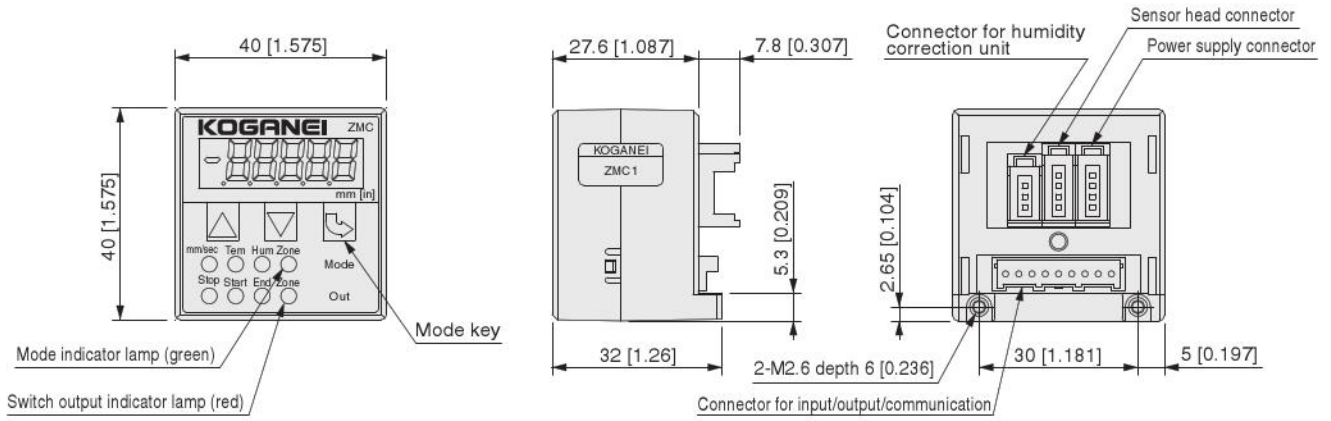

●ZMH1 Humidity correction unit

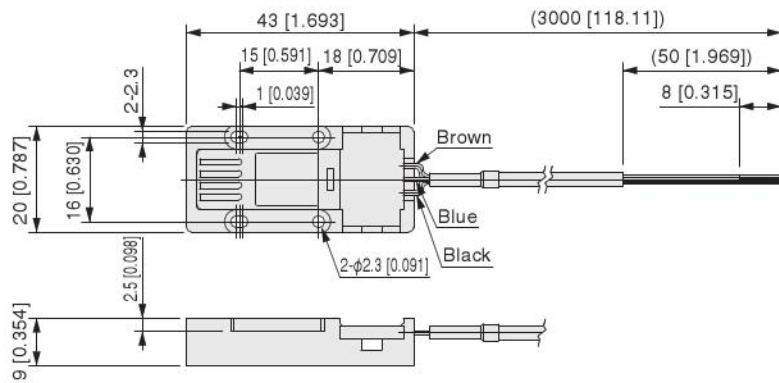

●ZMK1-□ Sensor head junction cable

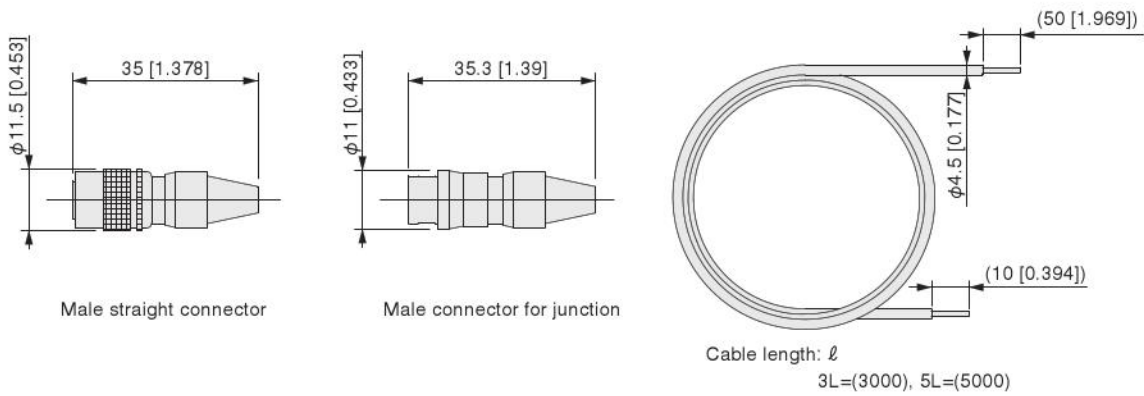

●ZMK2-□ Counter power supply junction cable

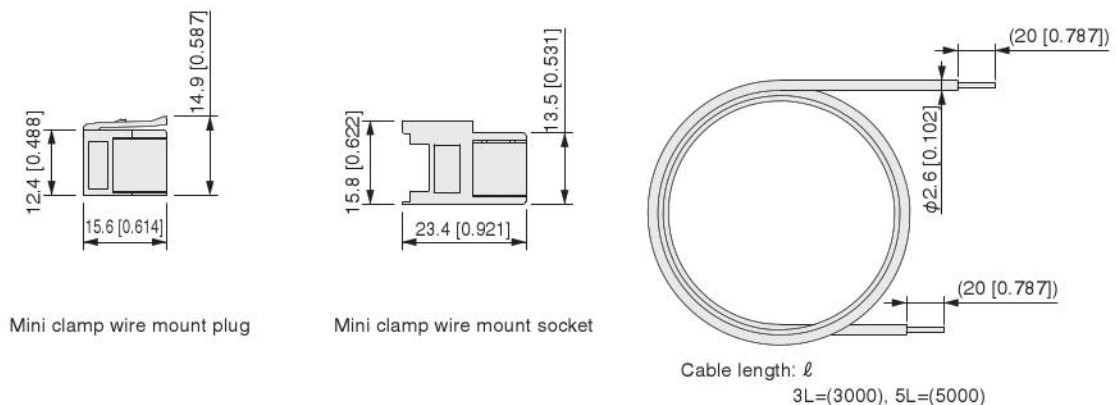

● ZMK3-□ Humidity correction unit junction cable

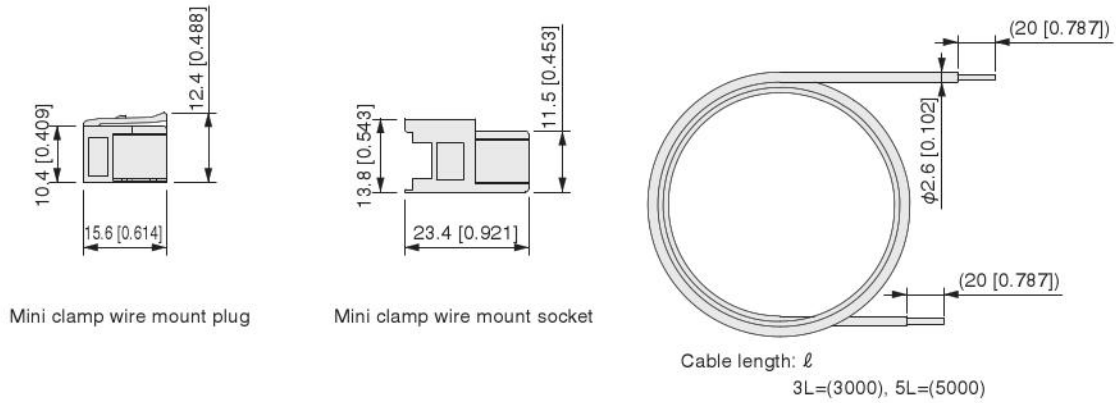

● PSU-BR Counter mounting bracket

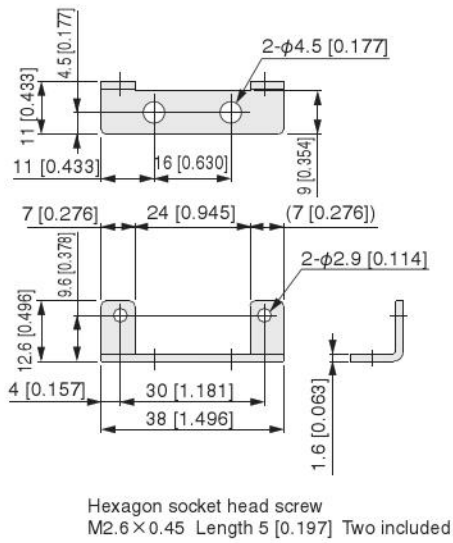

● FS1U-3M Mini clamp wire mount plug (for humidity correction unit)

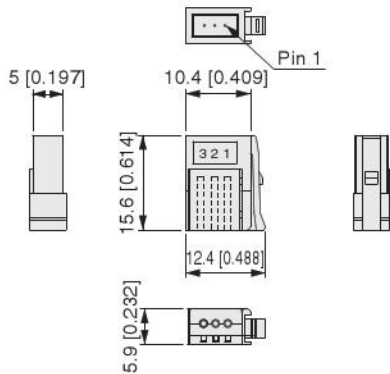

● FS1U-4M Mini clamp wire mount plug (for sensor head and counter power supply)

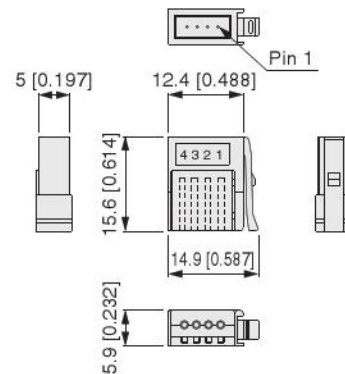

● KB100 Counter protective front cover

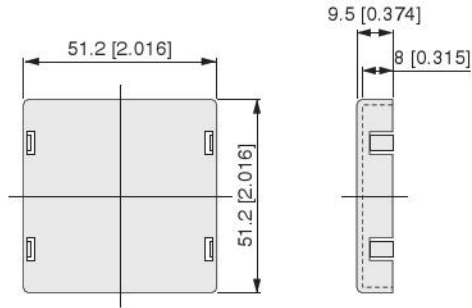

● PM100 Parts for counter panel mount

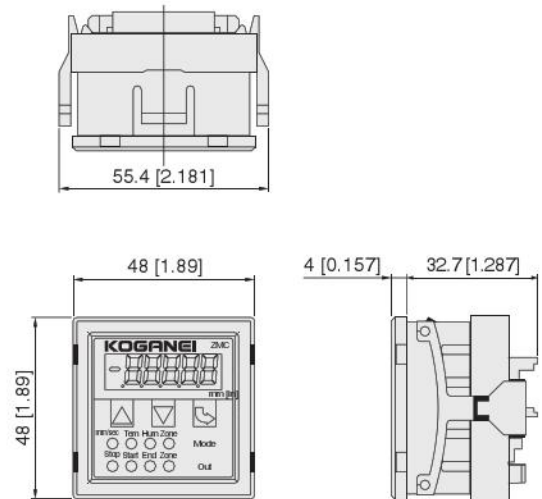

● Holes for sensor controller mounting (for panel mount)

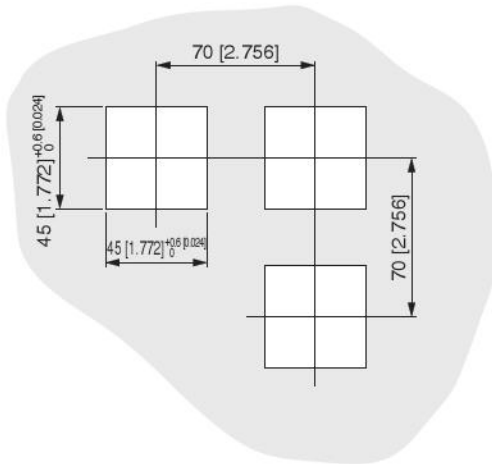

- Note 1: Use a mounting panel thickness of 1 to 3.2 mm [0.039 to 0.126 in].
 Note 2: For adjacent mounting, provide at least the amount of spacing shown above between holes.
 Note 3: **DIN43700** standard.

