

HIGH MULTI CYLINDERS



KOGANEI Brand

All products are **RoHS**-Compliant



Compact & direct mounting
Directly mountable without mounting bracket!

HIGH MULTI CYLINDERS

**Directly mountable without mounting bracket,
realizing clean lines by embedded sensor switch.**

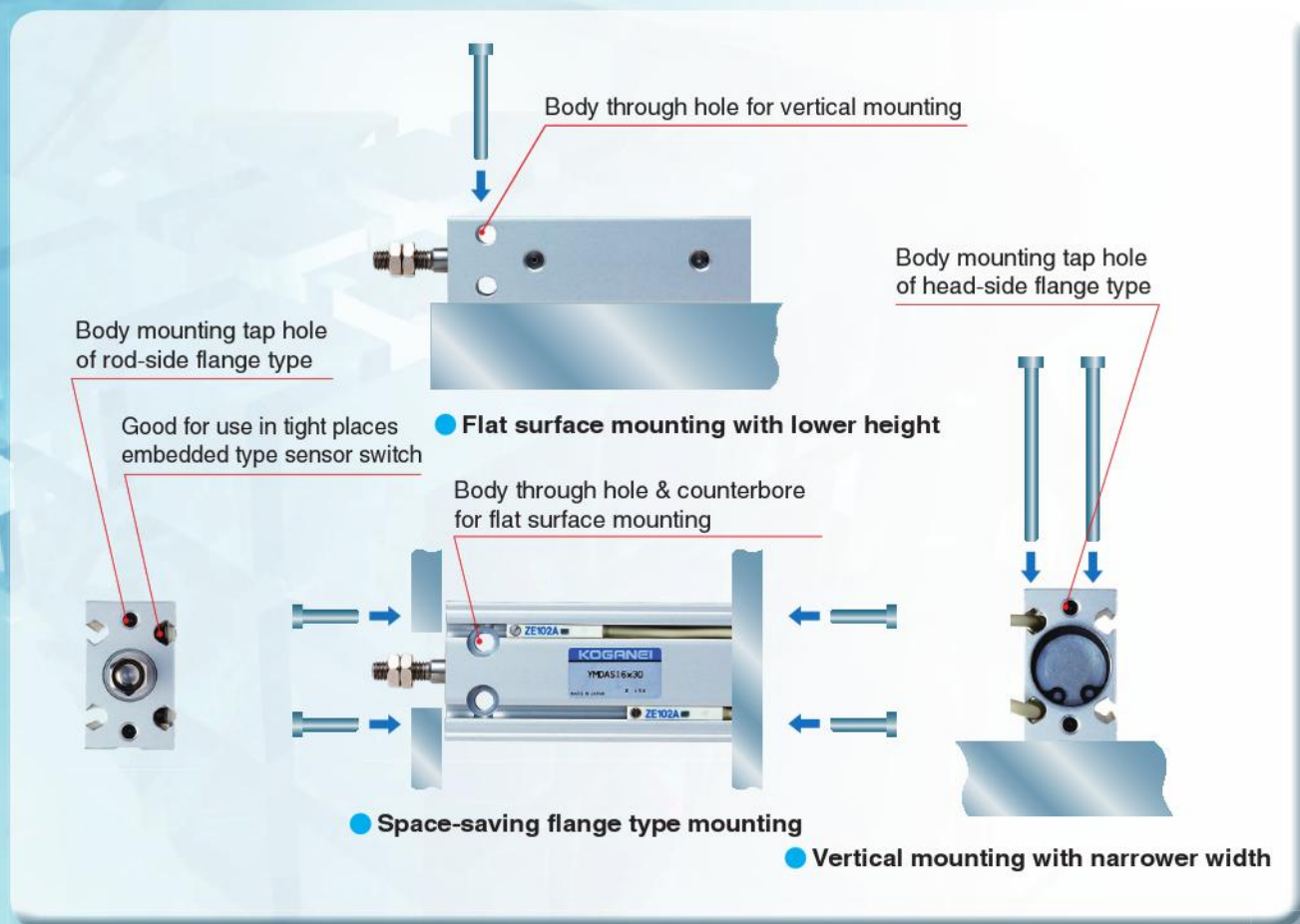

Compact & direct mounting

Rectangular body and 6-face-mounting enable a compact and direct mounting.

Standardizing cylinders with guides

Linear guide is installed to pursue space saving as well as non-rotating accuracy.

The embedded sensor switch is employed

The embedded type sensor switch is employed to prevent anything protruding from the main body. Sensor switches are placed in the sensor mounting grooves located on the 2 faces of main body.

VARIATION



■ Standard cylinders (double acting type) 11



■ Standard cylinders (single acting push type) 11



■ Standard cylinders (single acting pull type) 11



■ Non-rotating cylinders 18



■ Cylinders with guide 22







■ Sensor switches 27

I N D E X

Features	1
Safety Precautions	3
Handling Instructions and Precautions	7
Standard cylinders (Double acting type, Single acting push type, and Single acting pull type)	11
Order code	12
Inner construction and parts names	13
Dimensions	15
Non-rotating cylinders	16
Order code	19
Inner construction and parts names	20
Dimensions	21
Cylinders with guides	22
Order code	23
Inner construction and parts names	24
Dimensions	25
Sensor switches	27
Order code & Internal circuit diagram	26
Contact protection countermeasure & wiring instructions	30
Usable minimum cylinder stroke	31
Stroke end detection Sensor switch mounting position	32

Before selecting and using the products, please read all the "Safety Precautions" carefully to ensure proper product use. The Safety Precautions described below are to help you use the product safely and correctly, and to prevent injury or damage to you, other people, and assets. Be sure to observe these safety precautions together with the following safety regulations of ISO4414 (General rules and safety requirements for systems and their components), and JIS B 8370 (General rules relating to systems).

The directions are ranked according to degree of potential danger or damage: "DANGER", "WARNING", "CAUTION" and "ATTENTION."

 DANGER	Indicates situations that can be clearly predicted as dangerous. Death or serious injury may result if the situation is not avoided. It could also result in damage or destruction of assets.
 WARNING	Indicates situations that, while not immediately dangerous, could become dangerous. Death or serious injury may result if the situation is not avoided. It could also result in damage or destruction of assets.
 CAUTION	Indicates situations that, while not immediately dangerous, could become dangerous. Failure to avoid the situation creates the risk of minor or semi-serious injury. It could also result in damage or destruction of assets.
 ATTENTION	While there is little chance of injury, this content refers to points that should be observed for appropriate use of the product.

- This product was designed and manufactured for use in general industrial machinery.
- When selecting and handling equipment, the system designer or another person with sufficient knowledge and experience should always read the "Safety Precautions", "catalog", "instruction manual", and other literature before commencing operation. Improper handling is dangerous.
- After reading the instruction manual, catalog, and other documentation, always place them in a location that allows easy availability for reference to users of this product.
- Whenever transferring or lending the product to another person, always attach the catalog, instruction manual, and other information to the product where they are easily visible in order to ensure that the new user can use the product safely and properly.
- The danger, warning and caution items listed under these "Safety Precautions" do not cover all possible contingencies. Read the catalog and instruction manual carefully, and always keep safety first.

DANGER

- Do not use the product for the purposes listed below:
 1. Medical equipment related to maintenance or management of human lives or bodies.
 2. Machines or equipment designed for the purpose of moving or transporting people.
 3. Critical safety components in mechanical devices. This product has not been planned or designed for purposes that require high levels of safety. Using the product in any of the ways described above creates the risk of loss of human life.
- Do not use the product in locations with or near dangerous substances such as flammable or ignitable substances. This product is not explosion-proof. Doing so creates the risk of ignition and fire.
- When mounting the product and workpiece, always make sure they are firmly supported and secured in place. Falling, dropping, or abnormal operation of the product creates the risk of personal injury.
- Persons using a pacemaker or other similar medical devices should maintain a distance of at least 1 meter [3.28 ft] away from the product. Getting too close to the product creates the risk of malfunction of a pacemaker due to the strong magnet built into the product.
- Never attempt to modify the product in any way. Doing so creates the risk of injury, electric shock, fire, etc. due to abnormal operations.
- Never attempt inappropriate disassembly, assembly, or repair of the product relating to basic construction, or to its performance or functions. Doing so creates the risk of injury, electric shock, fire, etc.
- Do not allow water to splash on the product. Water spraying on the product, washing the product, or using the product under water creates the risk of malfunction, leading to injury, electric shock, fire, etc.
- While the product is in operation, avoid touching it with your hands or otherwise approaching too close. Also, do not attempt to make any adjustments to internal or attached mechanism, or to perform any type of adjustment (adjusting the mounting position of sensor switches, disconnecting piping tubes or sealed plugs, etc.) while the product is in operation. This may cause a sudden cylinder movement or any other items that creates the risk of personal injury.
- When operating the product, always install speed controllers, and gradually loosen the needle valve from a choked state to adjust the increase in speed. Failure to make this adjustment, sudden movements can take place by the air supply, which may cause the loss of human life.
- Do not apply the load exceeding the buckling/bending strength to the piston rod. This can cause to shorten the product operating life and to create abnormal wear or breakage of rods and tubes.
- Make sure to align the piston rod axis and the load moving direction. Failure to do so, straining force will be applied to the piston rod or the tube, causing abnormal wear or breakage.

WARNING

- Do not use the product in excess of its specification ranges. Doing so creates the risk of product breakdown, loss of function, or damage. It could also drastically reduce the product's operating life.
- Before supplying air or electricity to the device and before starting operation, always conduct a safety check of the area where the machine is operating. Unintentional supply of air or electricity creates the risk of electric shock or injury due to contact with moving parts.
- Do not touch terminals or switches while power is turned on. Doing so creates the risk of electric shock and abnormal operation.
- Do not allow the product to be thrown into fire. Doing so creates the risk of explosion, resulting in the release of toxic gasses.
- Do not sit on the product, place your foot on it, or place other objects on it. Doing so creates the risk of injury due to tripping or the product tipping over or dropping, resulting in product damage and abnormal, erratic or runaway operation.
- Before conducting maintenance, inspection, repair, replacement, or any other similar procedure, always completely cut off all air supply and confirm that residual pressure inside the product or in piping connected to the product is zero. In particular, be aware that residual air will still be in the compressor or storage tank. The cylinder may move abruptly if residual air pressure remains inside the piping, causing injury.
- Do not use the cylinder as a device aiming to absorb the shock or vibration of machinery. Doing so may create the risk of injury or the breakdown of the machinery.
- Do not allow lead wires of sensor switches and other cords to become damaged. Allowing a cord to become damaged, bent excessively, pulled, rolled up, placed under heavy object, or squeezed between two objects creates the risk of current leaks or defective continuity that can lead to fire, electric shock, or abnormal operation.
- While cylinder is in motion, do not apply external magnetic field to sensor switches. Doing so creates the risk of unintentional movement of the product, resulting in breakdown of equipment or personal injury.
- Use the product within the range of recommended load and specified speed. Using outside the range creates the risk of damaging the cylinder, resulting the breakdown of the equipment or personal injury.
- Use safety circuits or design a system that prevents damage to machinery and personal injury when the machine is shut down due to an emergency stop or electrical power failure.

- When the pressure is increased by external force, make sure to attach the relief equipment or any other means not to exceed the specified operating pressure of the cylinder. Pressure exceeding the specified operating pressure may lead to malfunction and breakdown.
- When the machine has been idle for over 48 hours or is in first operation after storage, it is possible that the contacting parts may have become stuck, leading to operation delays or sudden movements. In initial operation, be sure to perform trial operation to check whether the machine works properly.
- Never use the product in direct sunshine-suffered location like beach, near mercury lamp, or near a product likely to produce ozone. Deterioration of rubber parts caused by ozone may reduce the performance and function or stop the function.
- Because KOGANEI products may be used under a wide variety of conditions, decisions concerning conformance with a particular system should be made upon the careful evaluation by the person in charge of system design. Assurances concerning expected system performance and safety are the responsibility of the designer who decides system conformity. Be sure to use the latest catalogs and technical materials to study and evaluate specification details, to consider the possibility of machine breakdown, and to configure a system that ensures fail-safe safety and reliability.
- Do not use in locations that are subject to direct sunlight (ultraviolet rays), in locations with dust, salt, or iron particles, or in locations with media and/or ambient atmosphere that include organic solvents, phosphate ester type hydraulic oil, sulfur dioxide, chlorine gas, acids, etc. Such uses could lead to early shutdown of some functions, a sudden degradation of performance, and a reduced operating life. For details on materials used in the product, refer to the description of major parts.

CAUTION

- When mounting the product, leave room for adequate working space around it. Failure to do so will make it more difficult to conduct daily inspections or maintenance, which could eventually lead to system shutdown or damage to the product.
- Do not bring any magnetic media or memory within one meter [3.28 ft] of the product. Doing so creates the risk of damage to data on the magnetic media due to magnetism.
- The sensor switch should not be used in a location where high current or magnetic field is generated. This may cause the machine to malfunction. Also avoid using magnetic material for any parts used for mounting. Doing so creates the risk of magnetism leakage that causes malfunctions.
- Do not bring the product close to magnetized body. Bringing the product close to magnetized body or the location where high magnetic field is generated can magnetize the main body or table, resulting in the malfunction of sensor switches or defective operation due to attachment of the iron powder.
- Make absolute sure that sensor switches of other companies are not used for this product. Failure to do so can lead to malfunctions or runaway operations.
- Do not scratch, dent, or deform the actuator by climbing on the product, using it as a scaffold, or placing objects on top of it. Doing so creates the risk of damage to or breakage of the product, resulting in operational shutdown or degraded performance.
- Always post an "operations in progress" sign for installations, adjustments, or other operations, to avoid unintentional supplying of air or electrical power, etc. Unintended power or air supply can cause electric shock or sudden cylinder movement, creating the risk of personal injury.
- Do not apply excessive load to the cords, such as the lead wires of sensor switches mounted on the cylinder, in such manner as pulling, carrying by hands or placing heavy object on the cords. Doing so may cause the leak current or defective continuity, leading to fire, electric shock or malfunctions.

ATTENTION

- Whenever considering use of this product in situations or environments not specifically noted in the "catalog" or "instruction manual", or in applications where safety is an important requirement such as in aircraft facilities, combustion equipment, leisure equipment, safety equipment, and other places where human life or assets may be greatly affected, take adequate safety precautions such as allowing plenty of margin for ratings and performance, or fail-safe measures. Be sure to contact KOGANEI before use in such applications.
- Always check the "catalog" and other reference materials for product wiring and piping.
- Moving parts of machine and devices should be isolated with a protection cover so as not to be directly contacted by human body.
- Do not configure the control that may cause a workpiece to drop when in power outage. Be sure to configure the work/table-drop prevention control for the case of power outage or emergency stop of the machine.
- When handling the product, wear protective gloves, safety glasses, safety shoes, etc., as required.
- When the product can no longer be used or is no longer necessary, dispose of it appropriately as industrial waste.
- Pneumatic equipment can exhibit degraded performance and function over its operating life. Always conduct daily inspections of the pneumatic equipment, and confirm that all requisite system functions are satisfied, to prevent accidents from happening.
- For inquiries about the product, consult your nearest KOGANEI sales office or KOGANEI overseas group. The addresses and telephone numbers are shown on the back cover of this catalog.

Others

- Always observe the following items. KOGANEI shall not be held responsible for any problems that occur as a result of these items not being properly observed.
 1. When using this product in pneumatic systems, always use genuine KOGANEI parts or compatible products (recommended parts). When conducting maintenance and repairs, always use genuine KOGANEI parts or compatible products (recommended parts). Always observe the prescribed methods and procedures.
 2. Never attempt inappropriate disassembly or assembly of the product relating to basic construction, or its performance or functions.

KOGANEI shall not be held responsible for any problems that occur as a result of these safety precautions not being properly observed.

Warranty and General Disclaimer

1. Warranty Period

The warranty period for KOGANEI products is 180 days from the date of delivery.

2. Scope of Warranty and General Disclaimer

- (1) The KOGANEI product warranty covers individual products. When a product purchased from KOGANEI or from an authorized KOGANEI distributor malfunctions during the warranty period in a way that is attributable to KOGANEI responsibility, KOGANEI will repair or replace the product free of charge. Even if a product is still within the warranty period, its durability is determined by its operation cycles and other factors. Contact your nearest KOGANEI sales office or the KOGANEI overseas group for details.
- (2) KOGANEI shall not be held responsible for any losses or for any damage to other machinery caused by breakdown, loss of function, or loss of performance of KOGANEI products.
- (3) KOGANEI shall not be held responsible for any losses due to use or storage of the product in a way that is outside of the product specifications prescribed in KOGANEI catalogs and the instruction manual, and/or due to actions that violate the mounting, installation, adjustment, maintenance and other safety precautions.
- (4) KOGANEI shall not be held responsible for any losses caused by breakdown of the product due to factors outside the responsibility of KOGANEI, including but not limited to fire, natural disaster, the actions of third parties, and intentional actions or errors by you.



Design and Selection

WARNING

1. Check the specifications.

Using outside of specification range in voltage, current, temperature, shock, etc. creates the risk of breakdown or malfunctions of the product. Read the specification carefully before using.

2. Avoid mounting cylinders in close proximity to each other
When more than two cylinders with sensor switches are used close to each other, see page 31. This can cause the sensor switch to malfunction due to the magnetic interference with each other.

3. Where the position detection is made at mid-stroke, be cautious against the sensor switch ON time.

Be aware that, when the sensor switch is mounted at intermediate point of cylinder stroke to detect passing of the piston, too fast speed of the piston can shorten the sensor switch operation time, causing the load, such as programmable controllers, to fail to operate.

The highest detectable cylinder speed is

$$V \text{ [mm/s]} = \frac{\text{Sensor switch operating range [mm]}}{\text{Time required for load operation [ms]}} \times 1000$$

4. Keep wiring as short as possible.

The wiring for solid state sensor switches must be 30 m [98.4ft] or shorter, as stipulated by EN standard. For reed sensor switches, the longer wiring (10 m [32.8 ft] or longer) will lead to the larger capacitive surge current, which reduces the operating life of sensor switches. When a longer wiring cannot be avoided, provide the protective circuit described in the catalog.

If the load is inductive or capacitive, provide the appropriate protective circuit as described in the catalog.

5. Avoid repeated bending or excessive pulling of lead wires.

Applying repeated bending or pulling force on the lead wires could cause breaking the wire.

6. Check for leakage current.

2-lead wire solid state sensor switches produce the current (leakage current) even at off condition to activate the internal circuit. Ensure that they satisfy the following inequality:

Input off current of programmable controller > Leakage current
If above inequality is not satisfied, select 3-lead wire solid state sensor switch. And, if n-pieces sensors are connected in parallel, the leakage current increases by n times.

CAUTION

1. Check for internal voltage drop of sensor switches.

When reed sensor switches with indicator lamps or 2-lead wire solid state sensor switches are connected in series causes increasing internal voltage drop, and the load may fail to activate. Connecting n-pieces will drop the internal voltage by n times as large.

Ensure the circuit satisfy the following inequality.

$$\text{Power supply voltage} - \text{Internal voltage drop} \times n > \text{Minimum operating voltage of the load}$$

In relays with rated voltage of less than 24VDC, check to see the above inequality is satisfied even when n= 1.

When the above inequality is not satisfied, select a reed sensor switch without indicator lamp.

2. Do not use Koganei sensor switches with other company's cylinders.

The sensor switches are designed for use with our Koganei cylinders only. Using with other company's cylinders may not function properly.



Installation and adjustment

WARNING

1. Do not apply an external magnetic field to the sensor switch while the cylinder is in operation.

This may cause unintended operation, thereby damaging the device and causing personal injury.

CAUTION

1. Ensure a safe installation environment for the cylinders with sensors.

The sensor switch should not be used in a location where large current or high magnetic field is present. It could result in erratic operation.

Do not use magnetic material for the mounting portion. This may cause erratic operation.

2. Install the sensor switches in the center of their operating range.

Adjust the mounting position of the sensor switch so that the piston can stop in the center of the operating range (the sensor turned-on range). Setting the switch ON the end of the operating range (at the boundary of ON/OFF) may cause the operation to be unstable. Also be aware that the operating range will vary according to the temperature change.

3. Follow the tightening torque for the sensor switches when mounting.

Tightening the screw exceeding the allowable tightening torque may damage the mounting thread, mounting bracket, sensor switch etc. In addition insufficient tightening torque could cause the sensor switch position to be changed, thereby resulting in unstable operation. For details about tightening torque, refer to Page 31.

4. Do not carry the cylinder by its mounted sensor switch's lead wire.

After mounting a sensor switch on the cylinder, do not carry the cylinder by grabbing the lead wire. This may not only damage the lead wire but also apply stress to the inside of the sensor switch that may damage internal elements, so never perform such behavior.

5. Do not drop the sensor switches or bump them against other objects.

When handling the product, take care to avoid dropping it, allowing it to bump against other objects, or otherwise subjecting it to excessive impact (294.2 m/s [30G] or more). In the case of reed sensor switches, such behavior may cause the contact to malfunction, thereby giving a signal instantaneously or turning off the signal. And, this may change the contact interval, thereby deteriorating the sensor switch's sensitivity. As such, this may cause the device to malfunction. Even if the sensor switch case is not damaged, the inside of the sensor switch may be damaged, causing erratic operation.



Wiring

DANGER

1. Prevent nearby moving objects from coming into contact with sensor switches.

When the cylinders equipped with sensor switches are moving, or when moving objects are nearby, do not let them come into contact each other. In particular, lead wires may become worn or damaged causing unstable operation of the sensor switch. In the worst case, this may result in current leakage or electric shock.

2. Always turn off the power before performing wiring work.

Wiring work while the power is on could result in electric shock. Also, incorrect wiring could damage the sensor switch in an instant. Turn on the power after completing the wiring work.

WARNING

1. Check the "catalog" and other reference materials for correct wiring.

Improper wiring could result in abnormal operation.

2. Do not share wiring with power or high voltage lines.

Avoid wiring in parallel to or shared in the same conduit with power line and high-voltage line. Such wiring could cause the sensor switch and control circuit to suffer erratic operation by electric noise.

3. Be cautious against not bending the lead wire repeatedly or applying tension force to the wire.

Applying repeated bending stress or tension force to the lead wire may cause the wire to be broken.

4. Check polarity in the wiring.

For the sensor switch with the polarities (+, -, output) indicated, make sure that wiring connections are correct. The wrong polarities will result in damage to sensor switches.

CAUTION

1. Avoid short circuiting loads.

Turning on the sensor switch while the load is short-circuited causes overcurrent, which will damage the sensor switch in an instant.

Example of short-circuit load: Sensor switch's output lead wire is directly connected to the power supply.

Handling Instructions and Precautions



General precautions

Piping

1. Before piping for the cylinder, always flush the piping completely by blowing compressed air through it. Entering machining chips, sealing tape, or rust produced during piping work may cause operating failures including air leakage.
2. When screwing a piping or fitting into the cylinder, be sure to tighten them under appropriate tightening torque shown below.

Connecting thread	Tightening torque N · m [in · lbf]
M3 × 0.5	0.29 [2.57]
M5 × 0.8	1.37 [12.13]

Air supply

1. Use air as the media. For the use of any other media, consult our nearest sales office.
2. For air used in the cylinder, be sure to use clean air which does not contain degraded compressor oil, etc. Install an air filter (filtration of 40µm or less) near the cylinder or valve to remove sedimentation and dust. Also drain the air filter periodically. Entering of impurities and dust into the cylinder may cause its operating failure.

Lubrication

The cylinder can be used without lubrication, but if lubrication is required, use turbine oil Type 1 (ISO VG32) or equivalent. Do not use spindle oil and machine oil.

Atmosphere

1. When using the cylinder in a location subject to water droplet and oil droplet or likely to be exposed to dust, protect the cylinder with something to cover.
2. Do not use the cylinder in a corrosive atmosphere. The use of the cylinder under such atmosphere may damage the cylinder or cause its defective operation.
3. Do not use the cylinder under extremely dry condition.
4. The ambient temperature range most suitable for using the cylinder is 5 to 60°C [41 to 140°F]. The temperature exceeding 60°C [140°F] may damage the cylinder or cause defective operation, so be sure to avoid using the cylinder under such conditions. And, the temperature 5°C [41°F] or below may cause moisture in the air to be frozen, thereby damaging the cylinder or causing defective operation. Take some anti-freezing measure.

Sensor switch

Cylinder with magnet (the sensor cylinder) has a built-in magnet for sensor switch. Mounting the sensor switch enables the detection of piston position.



1. For mounting position and moving procedure of the sensor switch, refer to ① Page ②.
2. When an inductive load will be connected to reed sensor switches or if capacitive surge will occur, take some contact protection countermeasures. For contact protection countermeasures, refer to Page ②.

When used

1. Do not place your hands in the cylinder operating direction.
2. In the initial operation, be cautious against cylinder operating direction.
3. When the cylinder is retracting, be cautious against part of your body not be caught in a gap between the cylinder body and the end plate.
4. At the time of maintenance, be sure to check that there is no residual pressure within the cylinder before performing the work.
5. The cylinder speed should be 500 mm/s or less when using the cylinder. However, even within the allowable range, if the speed and load are large, install an external stopper to avoid applying direct impact to the cylinder.
6. Use the cylinder at the value below the allowable kinetic energy shown in the following table.

Cylinder bore mm [in.]	Allowable kinetic energy J [in · lbf]
6 [0.236]	0.007 [0.062]
10 [0.394]	0.018 [0.159]
16 [0.630]	0.031 [0.274]
20 [0.787]	0.044 [0.389]

- Kinetic energy of load is calculated using the following formula.

$$E_x = \frac{m}{2} v^2$$

Ex: Kinetic energy (J)
 m: Mass of load (kg)
 v: Piston speed (m/s)

Allowable lateral load

Use the cylinder under the condition below the following maximum allowable lateral load.

$$\text{Maximum allowable lateral load } W \leq \frac{\ell_2}{\ell_1 + \ell_2} \cdot R$$

Based on JIS Standard B8377 "Pneumatic cylinder"

Model	Dimensions			
	ϕD (mm [in.])	ℓ_2 (mm [in.])	ℓ (mm [in.])	R (N [lbf.])
YMDA□ (Double acting type)	6 [0.236]	9.0 [0.354]	25.0 [0.984]	0.99 [0.223]
	10 [0.394]	10.0 [0.394]	28.0 [1.102]	2.75 [0.618]
	16 [0.630]	11.5 [0.453]	29.5 [1.161]	7.04 [1.583]
	20 [0.787]	14.5 [0.571]	33.5 [1.319]	10.99 [2.471]
YMSA□ (Single acting push type)	6 [0.236]	17.5 [0.689]	21.5 [0.846]	0.74 [0.166]
	10 [0.394]	20.0 [0.787]	23.0 [0.906]	2.27 [0.510]
	16 [0.630]	21.0 [0.827]	25.0 [0.984]	5.97 [1.342]
	20 [0.787]	24.5 [0.965]	28.5 [1.122]	10.05 [2.259]
YMTA□ (Single acting pull type)	6 [0.236]	9.0 [0.354]	25.0 [0.984]	0.50 [0.112]
	10 [0.394]	11.0 [0.433]	28.0 [1.102]	1.58 [0.355]
	16 [0.630]	11.5 [0.453]	29.5 [1.161]	4.95 [1.113]
YMDAL□ (Non-rotating double acting type)	6 [0.236]	9.0 [0.354]	25.0 [0.984]	0.99 [0.223]
	10 [0.394]	10.0 [0.394]	33.0 [1.299]	2.75 [0.618]
	16 [0.630]	12.0 [0.472]	34.5 [1.358]	7.04 [1.583]
	20 [0.787]	14.5 [0.571]	43.5 [1.713]	10.99 [2.471]

Note: In the case of sensor cylinder, use the value ℓ_2 shown in the table by adding the value shown below as new ℓ_2 for calculating maximum allowable lateral load.

$$\phi 6 [0.236] \text{ to } \phi 16 [0.630]: +5 [0.197], \phi 20 [0.787]: +10 [0.394]$$

Others

In single acting type, when applying air from the piping port of the cylinder and leaving the cylinder for long hours with the spring compressed, the piston may not be returned even if the air is exhausted. In such cases, use double acting type cylinders.



Mounting

Mounting

- Any mounting posture is available but the mounting surface should be flat surface. Occurrence of twist or bending when in installation could not only deteriorate the accuracy but also cause air leakage or defective operations.
- Take caution that scratched or dented mounting surface of the cylinder may deteriorate the flatness.
- When the impact is too large, be sure to install some support bracket on the cylinder in addition to mounting screws.
- Ensure to keep enough strength for the cylinder and mounting screws.
- When the screws may be loosened by the impact or vibration, take measures against screw loosening.
- The sliding portion of the piston rod should not be scratched or dented. Scratched or dented sliding portion could damage seals and cause air leakage.
- Do not wipe out the grease applied on the piston rod and linear guide. This may cause the product to defective operation. If oil cannot be found, apply grease to them. (Grease: Universal type Lithium based grease No. 2)
- To tighten the cylinder, use the following tightening torque. When using female threads of the main body for mounting, tighten the screw under the tightening torque shown in ().

Cylinder bore mm [in.]	Screw size	Tightening torque N · m [in · lbf]
6 [0.236] · 10 [0.394]	M3 × 0.5	1.08 [9.56] (0.59 [5.22])
16 [0.630]	M4 × 0.7	2.45 [21.68] (1.37 [12.13])
20 [0.787]	M5 × 0.8	5.10 [45.14] (2.84 [25.14])

- When thrust of a cylinder with guide directly apply to the plate, apply the force to the rod axis center.

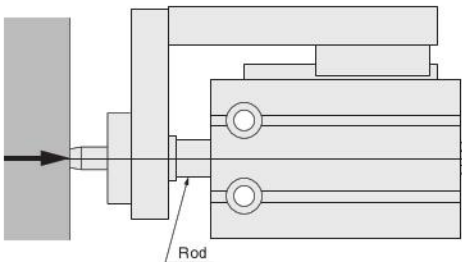

Avoid the following usages.

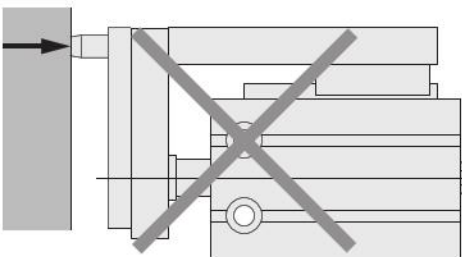

10. Mounting of workpiece

For the cylinder with guide, a workpiece can be mounted on two surfaces.

To tighten screws for mounting a workpiece, tighten at a torque within its limited range.

Front surface mounting

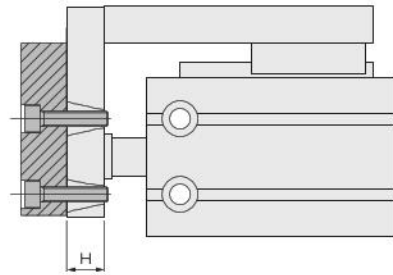

Upper surface mounting

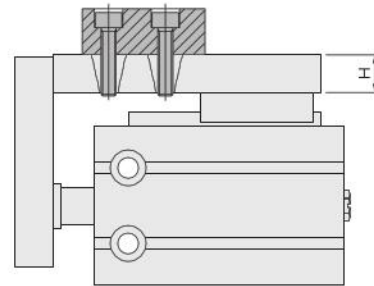

Cylinder bore mm [in.]	Screw size	Maximum tightening torque N · m [in · lbf]	H mm [in.]
6 [0.236]	M3 × 0.5	0.59 [5.22]	5 [0.197]
10 [0.394]	M3 × 0.5	0.59 [5.22]	6 [0.236]
16 [0.63]	M4 × 0.7	1.37 [12.13]	8 [0.315]
20 [0.787]	M5 × 0.8	2.84 [25.14]	10 [0.394]



- As the plate table is supported by the linear guide, do not apply strong impact or excessive moment to it when mounting a workpiece.
- When securing a workpiece in a plate table with screws, hold the table to tighten screws. Tightening with the body held may apply excessive moment to the guide portion, causing deteriorating the accuracy.

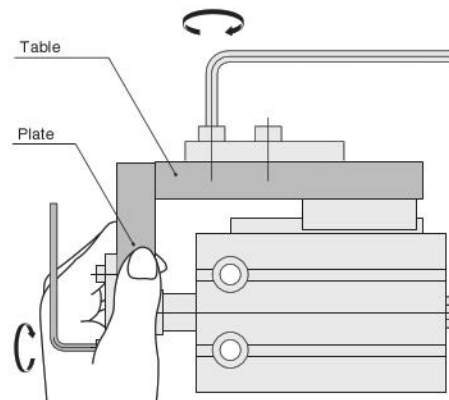

Handling Instructions and Precautions

Cylinder with guide - Allowable bending moment

Applications exceeding the allowable bending moment may damage the guide portion and deteriorate the accuracy, thereby affecting the operating life.

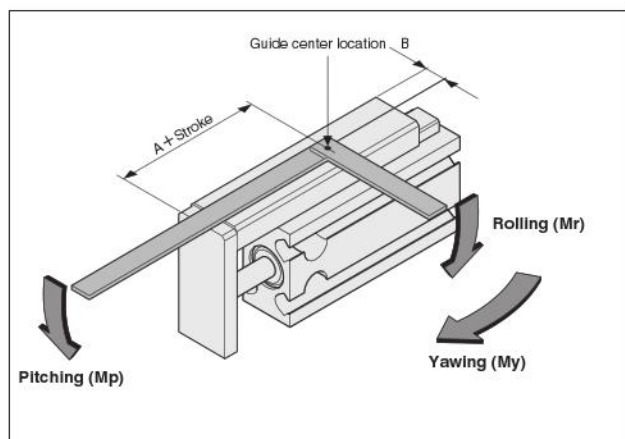

- For each moment center position, use the guide center location shown in the figure as the reference.

■ Allowable bending moment

N · m [in · lbf]

Allowable bending moment Cylinder bore mm [in.]	Mp (Pitching)	Mr (Rolling)	My (Yawing)
6 [0.236]	0.39 [3.45]	0.58 [5.13]	0.47 [4.16]
10 [0.394]	0.39 [3.45]	0.58 [5.13]	0.47 [4.16]
16 [0.630]	0.51 [4.51]	1.02 [9.03]	0.51 [4.51]
20 [0.787]	1.02 [9.03]	2.08 [18.41]	1.02 [9.03]

■ Moment from guide center location distance compensation

mm [in.]

Symbol Cylinder diameter mm [in.]	A	B
6 [0.236]	30 [1.181]	6 [0.236]
10 [0.394]	35 [1.378]	7 [0.276]
16 [0.630]	39 [1.535]	9.5 [0.374]
20 [0.787]	49 [1.929]	12 [0.472]

■ Allowable loads Fp, Fy, Fr calculation formula

Pitching moment

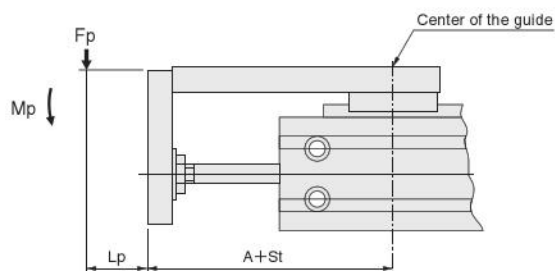

$$F_p = \frac{M_p \times 1000}{L_p + (A + St)} \text{ (N)}$$

Lp : Distance between the plate and the load (mm)

A + St : Distance between the plate and the center of the guide (mm)

St : Cylinder stroke (mm)

Yawing moment

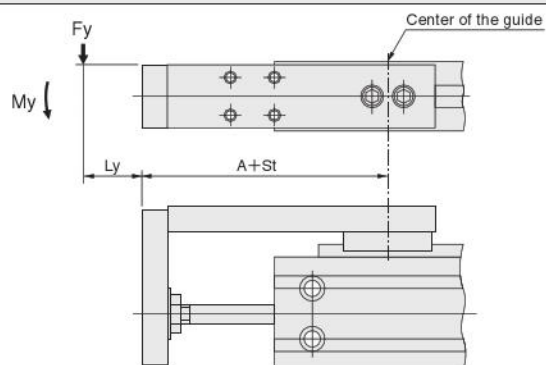

$$F_y = \frac{M_y \times 1000}{L_y + (A + St)} \text{ (N)}$$

Ly : Distance between the plate and the load (mm)

A + St : Distance between the plate and the center of the guide (mm)

St : Cylinder stroke (mm)

Rolling moment

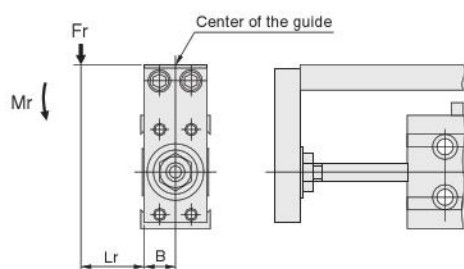

$$F_r = \frac{M_r \times 1000}{L_r + B} \text{ (N)}$$

Lr : Distance between the plate and the load (mm)

B : Distance to the center of the guide (mm)

Mounting procedure for the rear piping base

For the rear piping base of high multi cylinder with guide, the rear piping base is provided as an accessory when shipping from factory. Assemble the base on the unit in the manner shown below.

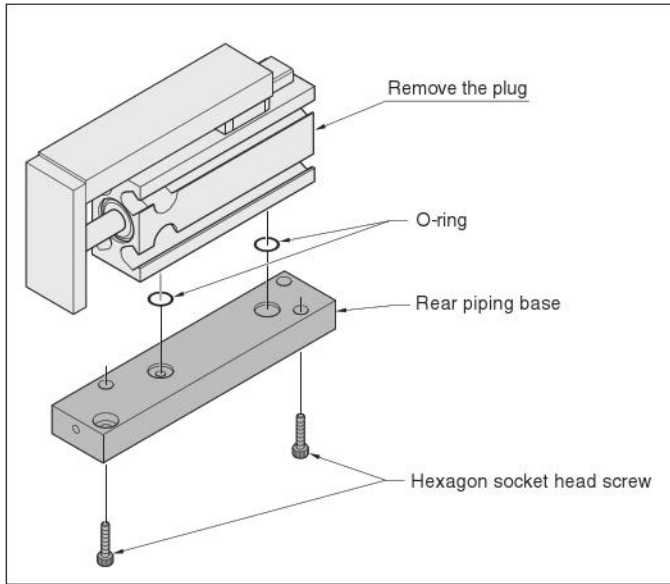

1. Remove a plug on the head cover.
(To attach the plug again, tighten at the tightening torque of 0.59 N·m [5.22 in·lbf].)
2. Place supplied O-rings as shown in the figure, and install the base with supplied hexagon socket head screws. At that time, use the following tightening torque.

Cylinder bore mm [in.]	Hexagon socket head screw	Tightening torque N · m [in · lbf]
6 [0.236] · 10 [0.394]	M3 × 0.5	0.59 [5.22]
16 [0.630]	M4 × 0.7	1.37 [12.13]
20 [0.787]	M5 × 0.8	2.84 [25.14]

Deflection of the plate end (Reference value)

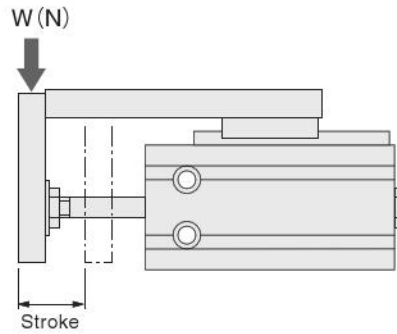

● Cylinder bore $\phi 6$ [0.236 in]

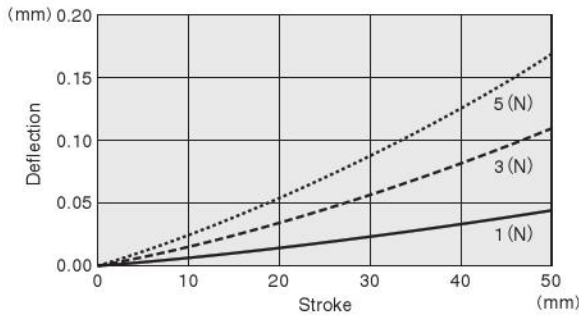

● Cylinder bore $\phi 16$ [0.630 in]

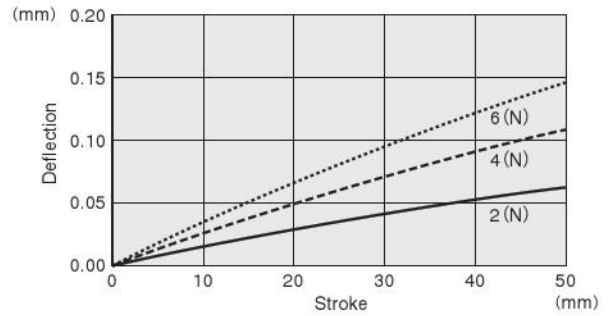

● Cylinder bore $\phi 10$ [0.394 in]

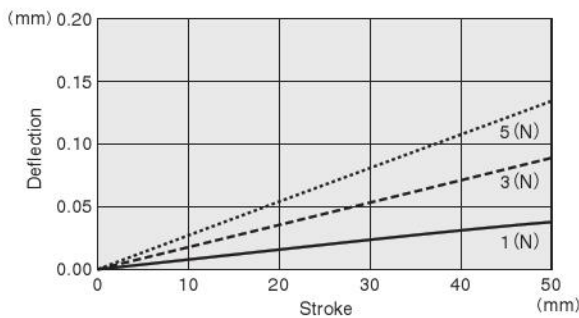

● Cylinder bore $\phi 20$ [0.787 in]

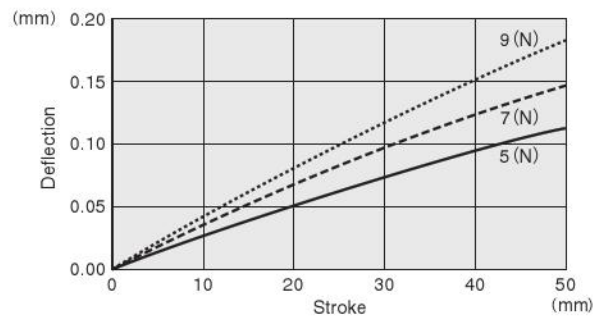

1 mm = 0.0394 in

1 N = 0.2248 lbf

High multi cylinder

Standard cylinders

Symbol

- Double acting type
- Single acting push type
- Single acting pull type



Specifications

Item	Cylinder bore	6 [0.236]	10 [0.394]	16 [0.630]	20 [0.787]
Operation type		Double acting type, single acting push/pull type			
Media		Air			
Operating pressure range MPa [psi.]	Double acting type	0.15~0.7 [22~102]	0.1~0.7 [15~102]	0.08~0.7 [12~102]	
	Single acting push type	0.2~0.7 [29~102]	0.15~0.7 [22~102]		
	Single acting pull type	0.3~0.7 [44~102]	0.2~0.7 [29~102]	0.15~0.7 [22~102]	
Proof pressure	MPa [psi.]	1.05 [152]			
Operating temperature range	°C [°F]	0~60 [32~140]			
Operating speed range	mm/s [in/sec]	50~500 [2~20] ^{Note}			
Cushion		Rubber bumper			
Lubrication		Not required (If used, use turbine oil class 1 [ISO VG32] or equivalent)			
Port size		M5×0.8			

Note: 100~500 mm/s [4~20 in/s] is applied for cylinder bore ϕ 6 [0.236] with stroke above 30 mm [1.18 in.].

Cylinder bore and stroke

Operation type	Bore	Standard stroke	mm
			Maximum manufacturable stroke
Double acting type	6 [0.236]	5 · 10 · 15 · 20 · 25 · 30 · 40 · 50 · 60	60
	10 [0.394]		
	16 [0.630]		
Single acting push type Single acting pull type	20 [0.787]	5 · 10 · 15 · 20 · 25 · 30 · 40 · 50 · 60 · 70 · 80 · 90 · 100	100
	6 [0.236]	5 · 10 · 15	15
	10 [0.394]		
	16 [0.630]		
20 [0.787]			

Thrust

Cylinder bore mm [in.]	Piston rod diameter mm [in.]	Operation	Pressure area mm ² [in ²]	Air pressure MPa [psi.]							
				0.1 [15]	0.2 [29]	0.3 [44]	0.4 [58]	0.5 [73]	0.6 [87]	0.7 [102]	
6 [0.236]	3 [0.118]	Double acting type	Push side	28.2 [0.0437]	—	5.6 [1.26]	8.5 [1.91]	11.3 [2.54]	14.1 [3.17]	16.9 [3.80]	19.7 [4.43]
			Pull side	21.2 [0.0329]	—	4.2 [0.94]	6.4 [1.44]	8.5 [1.91]	10.6 [2.38]	12.7 [2.85]	14.8 [3.33]
		Single acting push type	28.2 [0.0437]	—	0.7 [0.16]	3.5 [0.79]	6.4 [1.44]	9.2 [2.07]	12.0 [2.70]	14.8 [3.33]	
			Single acting pull type	21.2 [0.0329]	—	1.5 [0.34]	3.6 [0.81]	5.7 [1.28]	7.8 [1.75]	9.9 [2.23]	
10 [0.394]	5 [0.197]	Double acting type	Push side	78.5 [0.1217]	7.9 [1.78]	15.7 [3.53]	23.6 [5.31]	31.4 [7.06]	39.3 [8.83]	47.1 [10.59]	55 [12.36]
			Pull side	58.9 [0.0913]	5.9 [1.33]	11.8 [2.65]	17.7 [3.98]	23.6 [5.31]	29.5 [6.63]	35.3 [7.94]	41.2 [9.26]
		Single acting push type	78.5 [0.1217]	—	6.1 [1.37]	13.9 [3.12]	21.8 [4.90]	29.6 [6.65]	37.5 [8.43]	45.4 [10.21]	
		Single acting pull type	58.9 [0.0913]	—	2.2 [0.49]	8.1 [1.82]	13.9 [3.12]	19.8 [4.45]	25.7 [5.78]	31.6 [7.10]	
16 [0.630]	6 [0.236]	Double acting type	Push side	201 [0.312]	20.1 [4.52]	40.2 [9.04]	60.3 [13.56]	80.4 [18.07]	100.5 [22.59]	120.6 [27.11]	140.7 [31.63]
			Pull side	172 [0.267]	17.2 [3.87]	34.4 [7.73]	51.6 [11.60]	68.8 [15.47]	86 [19.33]	103.2 [23.20]	120.4 [27.07]
		Single acting push type	201 [0.312]	—	18.8 [4.23]	38.9 [8.74]	59.0 [13.26]	79.1 [17.78]	99.2 [22.30]	119.3 [26.82]	
		Single acting pull type	172 [0.267]	—	13.0 [2.92]	30.2 [6.79]	47.4 [10.66]	64.6 [14.52]	81.8 [18.39]	99.0 [22.26]	
20 [0.787]	10 [0.394]	Double acting type	Push side	314 [0.487]	31.4 [7.06]	62.8 [14.12]	94.2 [21.18]	125.6 [28.23]	157 [35.29]	188.4 [42.35]	219.8 [49.41]
			Pull side	235 [0.364]	23.5 [5.28]	47 [10.57]	70.5 [15.85]	94 [21.13]	117.5 [26.41]	141 [31.70]	164.5 [36.98]
		Single acting push type	314 [0.487]	—	44 [9.89]	75.4 [16.95]	106.8 [24.01]	138.2 [31.07]	169.6 [38.13]	201 [45.18]	
		Single acting pull type	235 [0.364]	—	28.2 [6.34]	51.7 [11.62]	75.2 [16.90]	98.7 [22.19]	122.2 [27.47]	145.7 [32.75]	

Spring return force (single acting type only)

Cylinder bore mm [in.]	Item Stroke mm [in.]	Zero stroke			Stroke end
		5 [0.197]	10 [0.394]	15 [0.591]	5 [0.197] · 10 [0.394] · 15 [0.591]
6 [0.236]		4.0 [0.90]	2.9 [0.65]	2.0 [0.45]	4.9 [1.10]
10 [0.394]		7.3 [1.64]	5 [1.12]	2.9 [0.65]	9.6 [2.16]
16 [0.630]		17.5 [3.93]	13.6 [3.06]	9.7 [2.18]	21.4 [4.81]
20 [0.787]		14.9 [3.35]	10.9 [2.45]	7.0 [1.57]	18.8 [4.23]

Standard cylinder order code

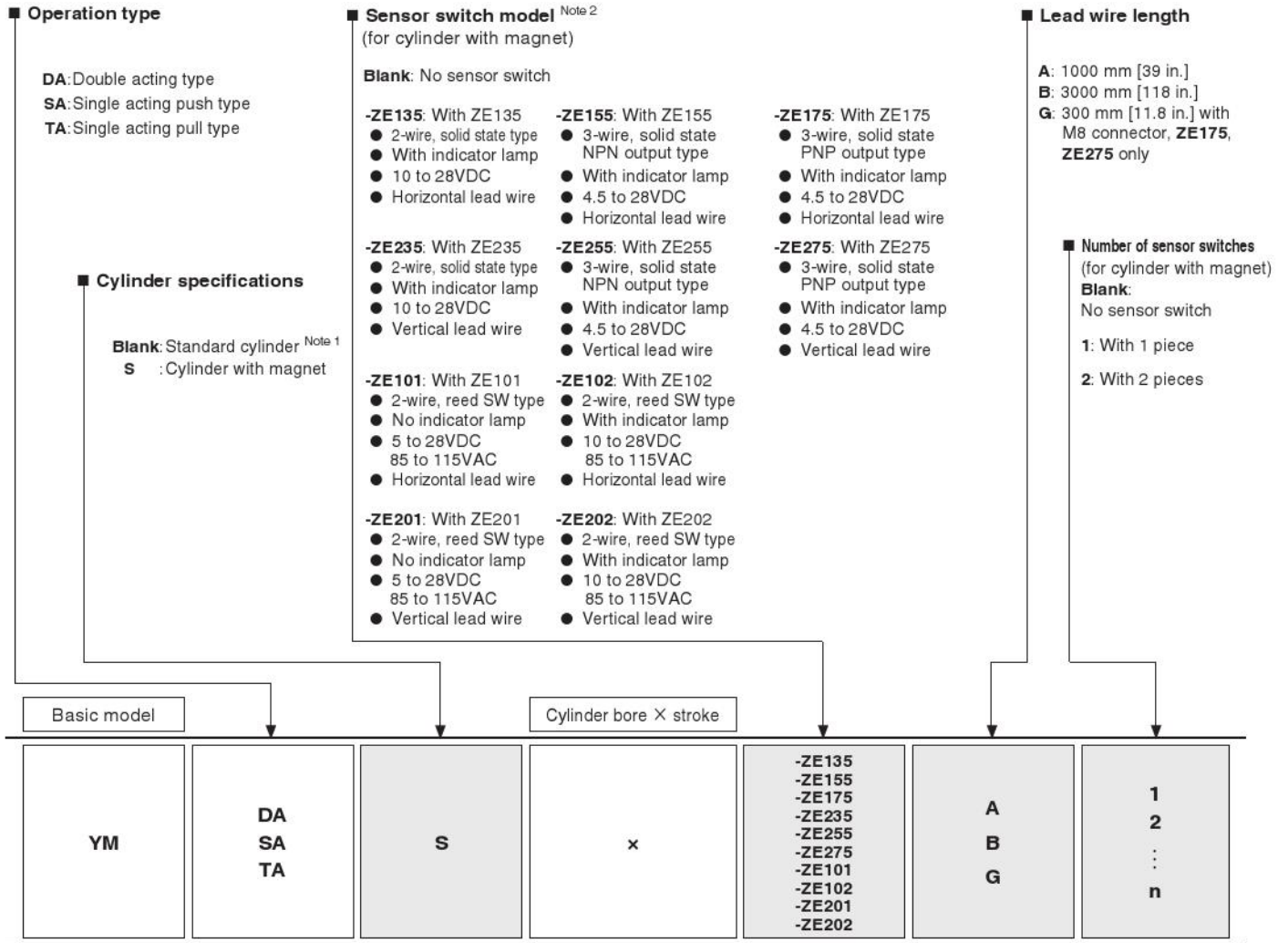

- Refer to cylinder bore and stroke table in page 11.
- For order code of sensor switch only, refer to page 23.

Note 1: The standard cylinder does not have built-in magnet for sensor switch.
 2: For details of sensor switch, refer to page 27.

Mass

● Double acting type

Model	Stroke												Additional mass for sensor switch		
	5	10	15	20	25	30	40	50	60	70	80	90	100	ZE□□□A ZE□□□G	ZE□□□B
YMDA6 YMDAS6	24 [0.85] (25 [0.88])	24 [0.85] (28 [0.99])	27 [0.95] (31 [1.09])	30 [1.06] (34 [1.20])	33 [1.16] (37 [1.31])	36 [1.27] (40 [1.41])	42 [1.48] (46 [1.62])	48 [1.69] (52 [1.83])	54 [1.90] (58 [2.05])	—	—	—	—	15 [0.53]	35 [1.23]
YMDA10 YMDAS10	33 [1.16] (34 [1.20])	32 [1.13] (36 [1.34])	36 [1.27] (42 [1.48])	40 [1.41] (46 [1.62])	44 [1.55] (50 [1.76])	48 [1.69] (54 [1.90])	56 [1.98] (62 [2.19])	64 [2.26] (70 [2.47])	72 [2.54] (78 [2.75])	—	—	—	—		
YMDA16 YMDAS16	70 [2.47] (73 [2.57])	69 [2.43] (79 [2.79])	75 [2.65] (85 [3.00])	81 [2.86] (91 [3.21])	87 [3.07] (97 [3.42])	93 [3.28] (103 [3.63])	105 [3.70] (115 [4.06])	117 [4.13] (127 [4.48])	129 [4.55] (139 [4.90])	—	—	—	—		
YMDA20 YMDAS20	126 [4.44] (154 [5.43])	139 [4.90] (167 [5.89])	152 [5.36] (180 [6.35])	165 [5.82] (193 [6.81])	178 [6.28] (206 [7.27])	191 [6.74] (219 [7.72])	217 [7.65] (245 [8.64])	243 [8.57] (271 [9.56])	269 [9.49] (297 [10.48])	295 [10.41] (323 [11.39])	321 [11.32] (349 [12.31])	347 [12.24] (375 [13.23])	373 [13.16] (401 [14.14])		

Note: Values in parentheses are for cylinder with magnet.

● Single acting push type

Model	Stroke			Additional mass for sensor switch	
	5	10	15	ZE□□□A ZE□□□G	ZE□□□B
YMSA6 YMSAS6	25 [0.88] (28 [0.99])	28 [0.99] (31 [1.09])	31 [1.09] (34 [1.20])	15 [0.53]	35 [1.23]
YMSA10 YMSAS10	33 [1.16] (39 [1.38])	37 [1.31] (43 [1.52])	41 [1.45] (47 [1.66])		
YMSA16 YMSAS16	72 [2.54] (82 [2.89])	78 [2.75] (88 [3.10])	84 [2.96] (94 [3.32])		
YMSA20 YMSAS20	144 [5.08] (172 [6.07])	157 [5.54] (185 [6.53])	170 [6.00] (198 [6.98])		

Note: Values in parentheses are for cylinder with magnet.

● Single acting pull type

Model	Stroke			Additional mass for sensor switch	
	5	10	15	ZE□□□A ZE□□□G	ZE□□□B
YMTA6 YMTAS6	25 [0.88] (28 [0.99])	28 [0.99] (31 [1.09])	31 [1.09] (34 [1.20])	15 [0.53]	35 [1.23]
YMTA10 YMTAS10	35 [1.23] (41 [1.45])	39 [1.38] (45 [1.59])	43 [1.52] (49 [1.73])		
YMTA16 YMTAS16	75 [2.65] (85 [3.00])	81 [2.86] (91 [3.21])	87 [3.07] (97 [3.42])		
YMTA20 YMTAS20	142 [5.01] (170 [6.00])	155 [5.47] (183 [6.46])	168 [5.93] (196 [6.91])		

Note: Values in parentheses are for cylinder with magnet.

Inner construction

■ Double acting type

- ϕ 6 [0.236]

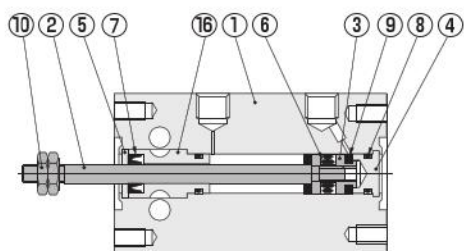

- ϕ 10 [0.394] , ϕ 16 [0.630]

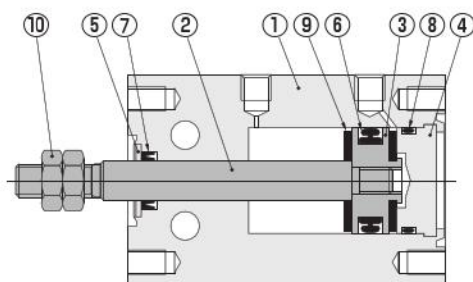

Note: Head cover of ϕ 16 [0.630] is secured by a snap ring (hard steel).

- ϕ 20 [0.787]

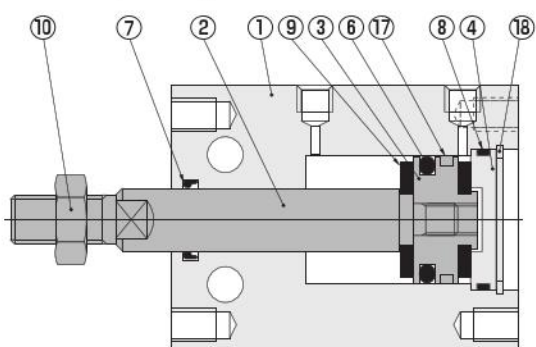

- Sensor cylinder

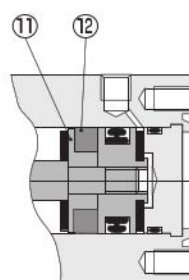

■ Single acting push type

- ϕ 6 [0.236]

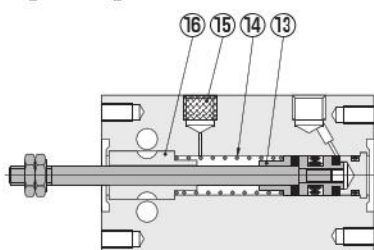

- ϕ 10 [0.394] , ϕ 16 [0.630]

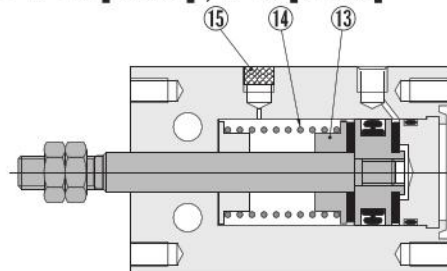

Note: Head cover of ϕ 16 [0.630] is secured by a snap ring (hard steel).

- ϕ 20 [0.787]

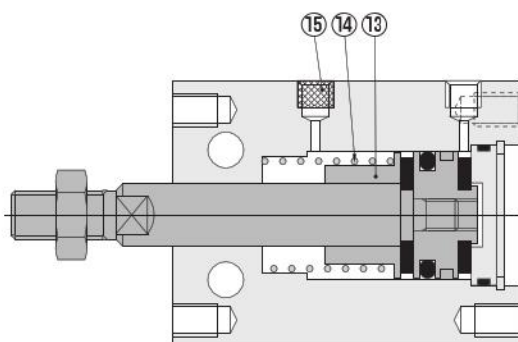

■ Single acting pull type

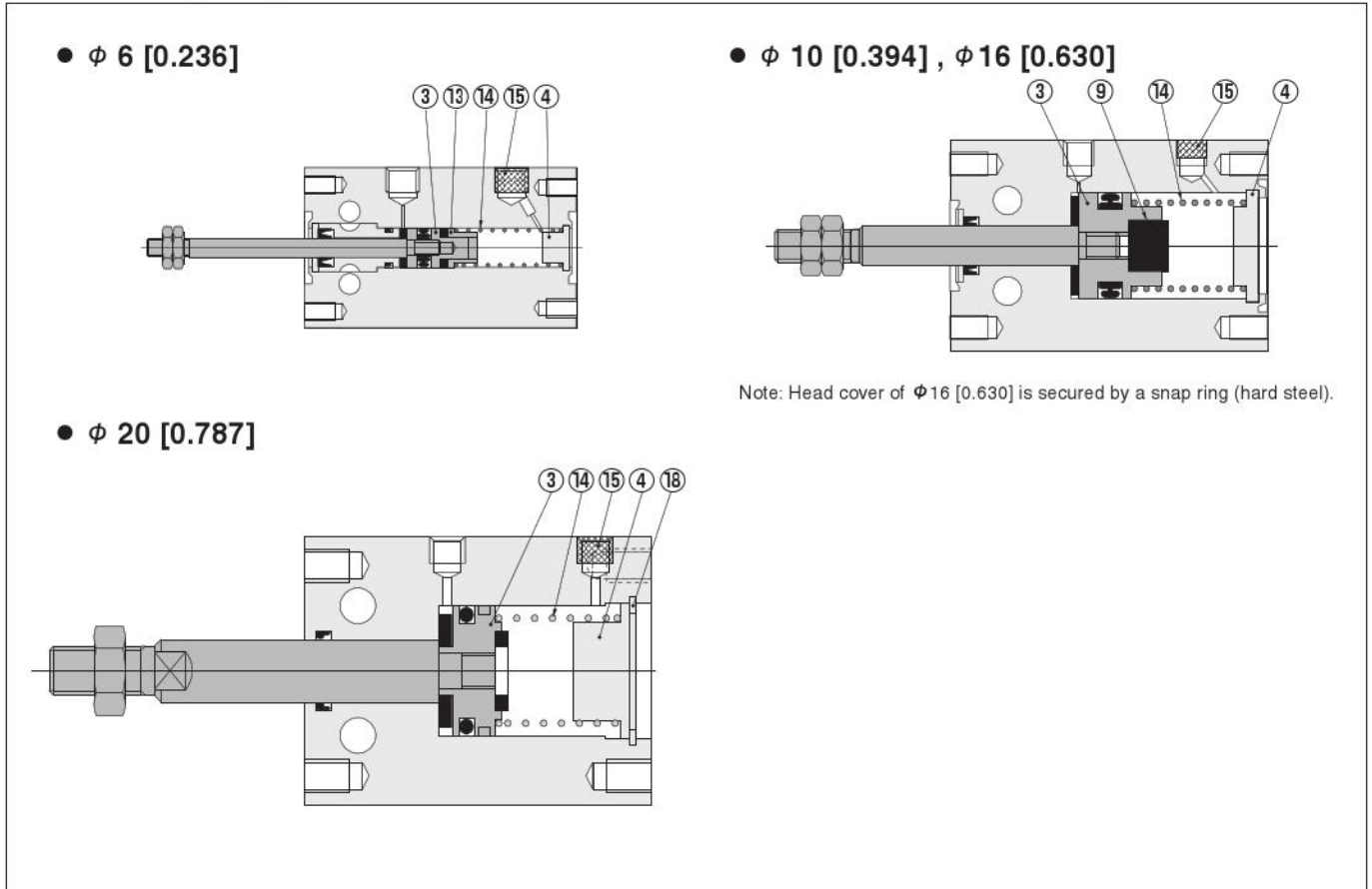

Parts names and major part materials

No	Name	Material
①	Cylinder body	Aluminum alloy (special anti-abrasion treated, anodized for $\phi 6$ [0.236] only)
②	Piston rod	Stainless steel (hard chrome plated for $\phi 20$ [0.787] only)
③	Piston	Brass (aluminum alloy for $\phi 20$ [0.787] only [special anti-rust treated])
④	Head cover	Aluminum alloy (special anti-rust treated)
⑤	Seal holder	Aluminum alloy (special anti-rust treated)
⑥	Piston seal	Synthetic rubber (NBR)
⑦	Rod seal	Synthetic rubber (NBR)
⑧	O-ring	Synthetic rubber (NBR)
⑨	Bumper	Synthetic rubber (NBR)
⑩	Rod end nut	Steel (nickel plated, zinc plated for $\phi 20$ [0.787] only)
⑪	Support	Brass (aluminum alloy for $\phi 20$ [0.787] only [special anti-rust treated])
⑫	Magnet	Plastic magnet
⑬	Collar	Brass (aluminum alloy for $\phi 20$ [0.787] only [special anti-rust treated])
⑭	Spring	Piano wire
⑮	Filter	Porous metal
⑯	Rod cover	Aluminum alloy (special anti-abrasion treated)
⑰	Wear ring	Plastic
⑱	Snap ring	Hard steel

List of seals used

Cylinder bore mm [in.]	Type Name	Standard cylinder	
		Rod seal	Piston seal
6 [0.236]		MYR-3	COP-6L
10 [0.394]		MYR-5	COP-10L
16 [0.630]		MYR-6	COP-16L
20 [0.787]		MYR-10	COP-20

Dimensions for double acting type mm [in.]

YMDA □ ×

- $\phi 6$ [0.236], $\phi 10$ [0.394], $\phi 16$ [0.630]

CAUTION Dimensions A to D for the stroke 5 mm [0.197 in.] of the standard cylinder are dimensions of the cylinder with magnet.

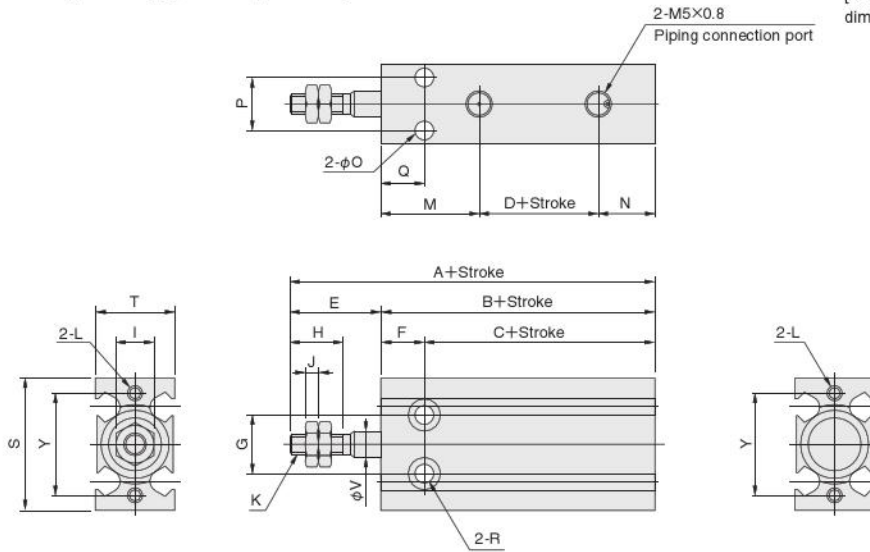

Type		Standard cylinder <small>Note</small>				Cylinder with magnet				E	F	G	H	I	J	K
Bore	Symbol	A	B	C	D	A	B	C	D							
6	[0.236]	43 [1.693]	28 [1.102]	21 [0.827]	2 [0.079]	48 [1.890]	33 [1.299]	26 [1.024]	7 [0.276]	15 [0.591]	7 [0.276]	11 [0.433]	7 [0.276]	5.5 [0.217]	1.8 [0.071]	M3 × 0.5
10	[0.394]	48 [1.890]	31 [1.220]	23 [0.906]	2.5 [0.098]	53 [2.087]	36 [1.417]	28 [1.102]	7.5 [0.295]	17 [0.669]	8 [0.315]	11 [0.433]	10 [0.394]	7 [0.276]	2.4 [0.094]	M4 × 0.7
16	[0.630]	53 [2.087]	35 [1.378]	26 [1.024]	3 [0.118]	58 [2.283]	40 [1.575]	31 [1.220]	8 [0.315]	18 [0.709]	9 [0.354]	14 [0.551]	12 [0.472]	8 [0.315]	3.2 [0.126]	M5 × 0.8

Type	L	M	N	O	P	Q	R	S	T	V	Y
6 [0.236]	M3 × 0.5 Depth 5 [0.197]	15.5 [0.610]	10.5 [0.413]	3.4 [0.134]	8 [0.315]	7 [0.276]	$\phi 3.4$ [0.134] Counterbore $\phi 6$ [0.236] Depth 5 [0.197] (both sides)	24 [0.945]	13 [0.512]	3 [0.118]	19 [0.748]
10 [0.394]	M3 × 0.5 Depth 5 [0.197]	18 [0.709]	10.5 [0.413]	3.4 [0.134]	10 [0.394]	8 [0.315]	$\phi 3.4$ [0.134] Counterbore $\phi 6$ [0.236] Depth 5 [0.197] (both sides)	25 [0.984]	15 [0.591]	5 [0.197]	19 [0.748]
16 [0.630]	M4 × 0.7 Depth 6 [0.236]	20 [0.787]	12 [0.472]	4.5 [0.177]	12 [0.472]	9 [0.354]	$\phi 4.5$ [0.177] Counterbore $\phi 7.6$ [0.299] Depth 6.5 [0.256] (both sides)	33 [1.299]	20 [0.787]	6 [0.236]	25 [0.984]

Note: Dimensions A to D for the stroke 5 mm [0.197 in.] are dimensions of the cylinder with magnet.

- $\phi 20$ [0.787]

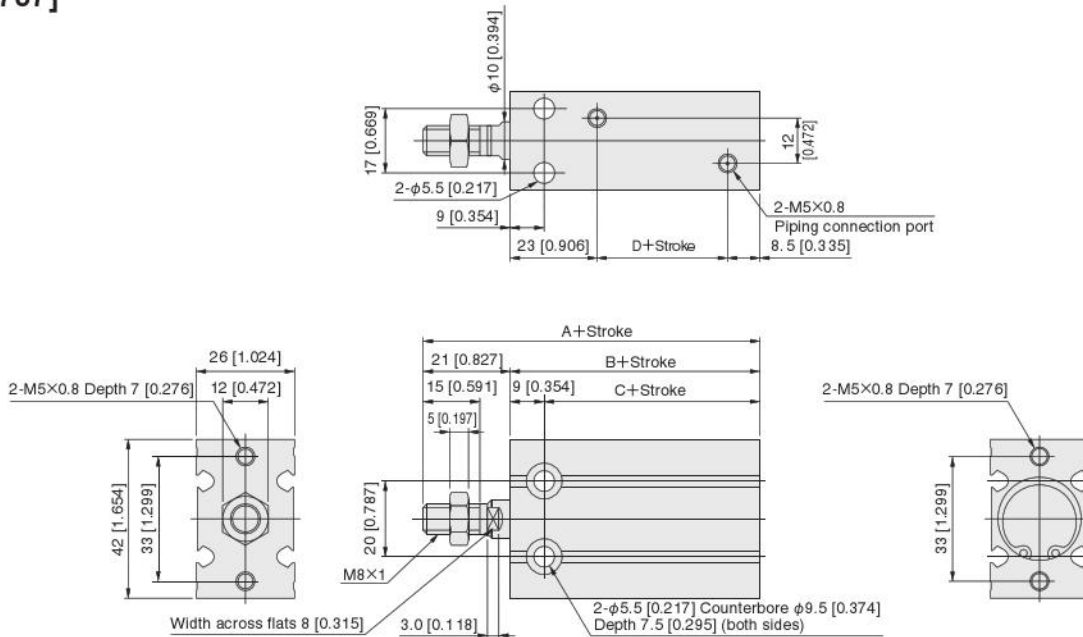

Type		Standard cylinder				Cylinder with magnet			
Bore	Symbol	A	B	C	D	A	B	C	D
20	[0.787]	61 [2.402]	40 [1.575]	31 [1.220]	8.5 [0.335]	71 [2.795]	50 [1.969]	41 [1.614]	18.5 [0.728]

Dimensions for single acting push type mm [in.]

YMSA□ ×

- $\phi 6$ [0.236], $\phi 10$ [0.394], $\phi 16$ [0.630]

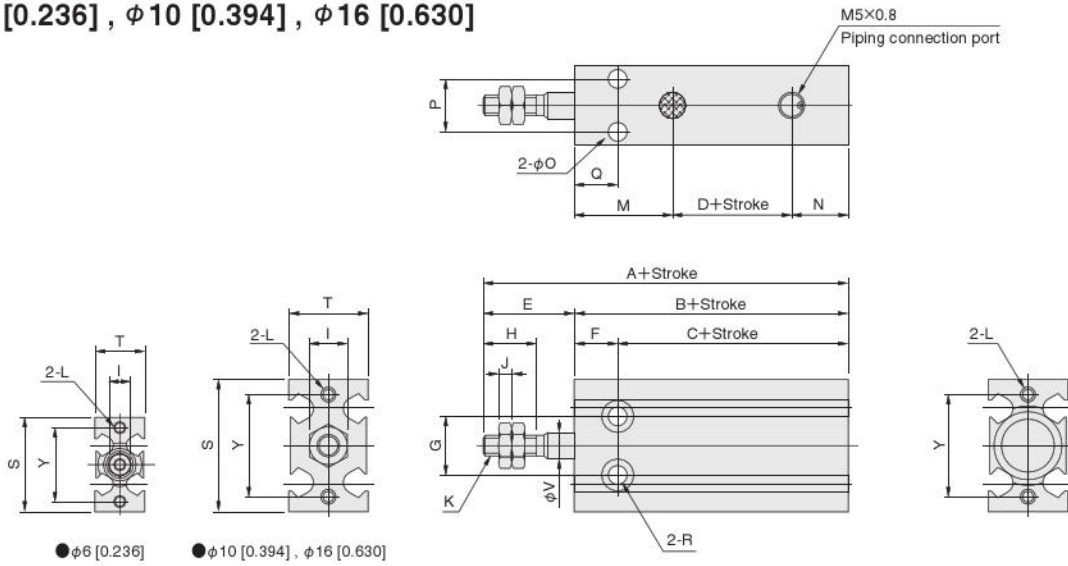

Type		Standard cylinder				Cylinder with magnet				mm [in.]							
Bore	Symbol	A	B	C	D	A	B	C	D	E	F	G	H	I	J	K	
6	[0.236]	48 [1.890]	33 [1.299]	26 [1.024]	7 [0.276]	53 [2.087]	38 [1.496]	31 [1.220]	12 [0.472]	15 [0.591]	7 [0.276]	11 [0.433]	7 [0.276]	5.5 [0.217]	1.8 [0.071]	M3 × 0.5	
10	[0.394]	53 [2.087]	36 [1.417]	28 [1.102]	7.5 [0.295]	58 [2.283]	41 [1.614]	33 [1.299]	12.5 [0.492]	17 [0.669]	8 [0.315]	11 [0.433]	10 [0.394]	7 [0.276]	2.4 [0.094]	M4 × 0.7	
16	[0.630]	58 [2.283]	40 [1.575]	31 [1.220]	8 [0.315]	63 [2.480]	45 [1.772]	36 [1.417]	13 [0.512]	18 [0.709]	9 [0.354]	14 [0.551]	12 [0.472]	8 [0.315]	3.2 [0.126]	M5 × 0.8	

Type		L	M	N	O	P	Q	R		S	T	V	Y
Bore	Symbol	mm [in.]											
6	[0.236]	M3 × 0.5 Depth 5 [0.197]	15.5 [0.610]	10.5 [0.413]	3.4 [0.134]	8 [0.315]	7 [0.276]	$\phi 3.4$ [0.134] Counterbore $\phi 6$ [0.236] Depth 5 [0.197] (both sides)	24 [0.945]	13 [0.512]	3 [0.118]	19 [0.748]	
10	[0.394]	M3 × 0.5 Depth 5 [0.197]	18 [0.709]	10.5 [0.413]	3.4 [0.134]	10 [0.394]	8 [0.315]	$\phi 3.4$ [0.134] Counterbore $\phi 6$ [0.236] Depth 5 [0.197] (both sides)	25 [0.984]	15 [0.591]	5 [0.197]	19 [0.748]	
16	[0.630]	M4 × 0.7 Depth 6 [0.236]	20 [0.787]	12 [0.472]	4.5 [0.177]	12 [0.472]	9 [0.354]	$\phi 4.5$ [0.177] Counterbore $\phi 7.6$ [0.299] Depth 6.5 [0.256] (both sides)	33 [1.299]	20 [0.787]	6 [0.236]	25 [0.984]	

- $\phi 20$ [0.787]

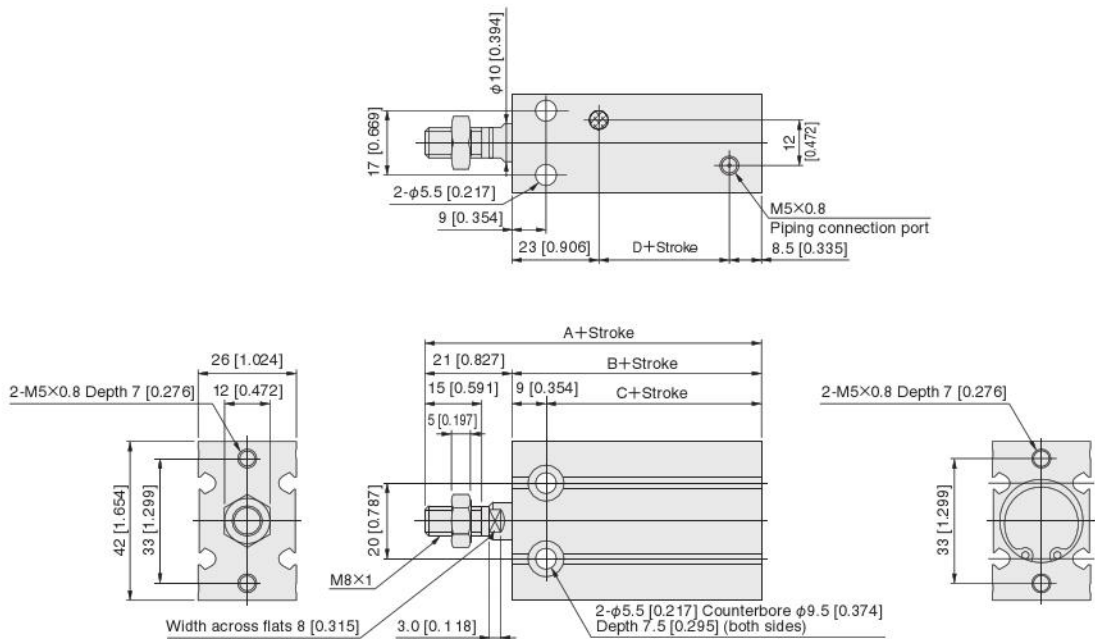

Type		Standard cylinder				Cylinder with magnet			
Bore	Symbol	A	B	C	D	A	B	C	D
20	[0.787]	66 [2.598]	45 [1.772]	36 [1.417]	13.5 [0.531]	76 [2.992]	55 [2.165]	46 [1.811]	23.5 [0.925]

Dimensions for single acting pull type mm [in.]

YMTA □ ×

- $\phi 6$ [0.236], $\phi 10$ [0.394], $\phi 16$ [0.630]

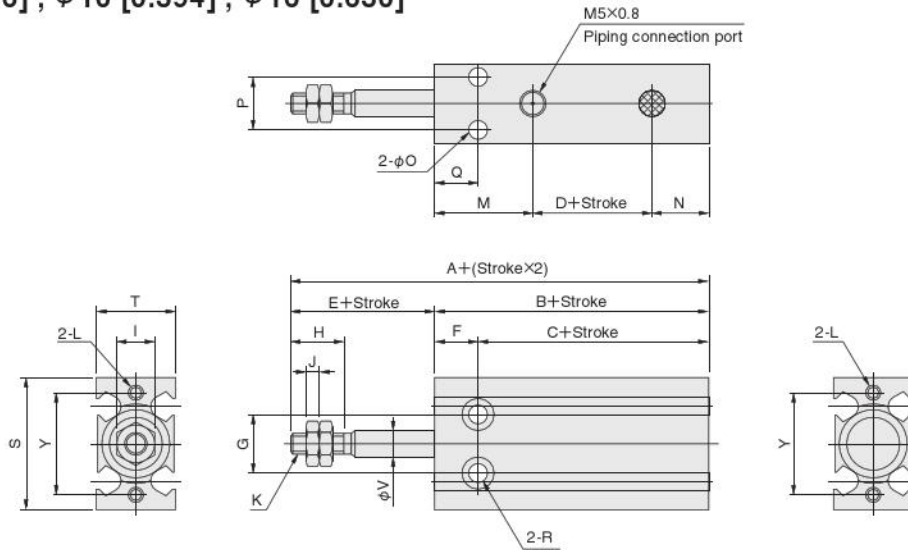

Type		Standard cylinder				Cylinder with sensor				mm [in.]						
Bore	Symbol	A	B	C	D	A	B	C	D	E	F	G	H	I	J	K
6	[0.236]	48 [1.890]	33 [1.299]	26 [1.024]	7 [0.276]	53 [2.087]	38 [1.496]	31 [1.220]	12 [0.472]	15 [0.591]	7 [0.276]	11 [0.433]	7 [0.276]	5.5 [0.217]	1.8 [0.071]	M3 × 0.5
10	[0.394]	53 [2.087]	36 [1.417]	28 [1.102]	7.5 [0.295]	58 [2.283]	41 [1.614]	33 [1.299]	12.5 [0.492]	17 [0.669]	8 [0.315]	11 [0.433]	10 [0.394]	7 [0.276]	2.4 [0.094]	M4 × 0.7
16	[0.630]	58 [2.283]	40 [1.575]	31 [1.220]	8 [0.315]	63 [2.480]	45 [1.772]	36 [1.417]	13 [0.512]	18 [0.709]	9 [0.354]	14 [0.551]	12 [0.472]	8 [0.315]	3.2 [0.126]	M5 × 0.8

Type	Symbol	L	M	N	O	P	Q	R		S	T	V	Y
6	[0.236]	M3 × 0.5 Depth 5 [0.197]	15.5 [0.610]	10.5 [0.413]	3.4 [0.134]	8 [0.315]	7 [0.276]	$\phi 3.4$ [0.134] Counterbore $\phi 6$ [0.236] Depth 5 [0.197] (both sides)		24 [0.945]	13 [0.512]	3 [0.118]	19 [0.748]
10	[0.394]	M3 × 0.5 Depth 5 [0.197]	18 [0.709]	10.5 [0.413]	3.4 [0.134]	10 [0.394]	8 [0.315]	$\phi 3.4$ [0.134] Counterbore $\phi 6$ [0.236] Depth 5 [0.197] (both sides)		25 [0.984]	15 [0.591]	5 [0.197]	19 [0.748]
16	[0.630]	M4 × 0.7 Depth 6 [0.236]	20 [0.787]	12 [0.472]	4.5 [0.177]	12 [0.472]	9 [0.354]	$\phi 4.5$ [0.177] Counterbore $\phi 7.6$ [0.299] Depth 6.5 [0.256] (both sides)		33 [1.299]	20 [0.787]	6 [0.236]	25 [0.984]

- $\phi 20$ [0.787]

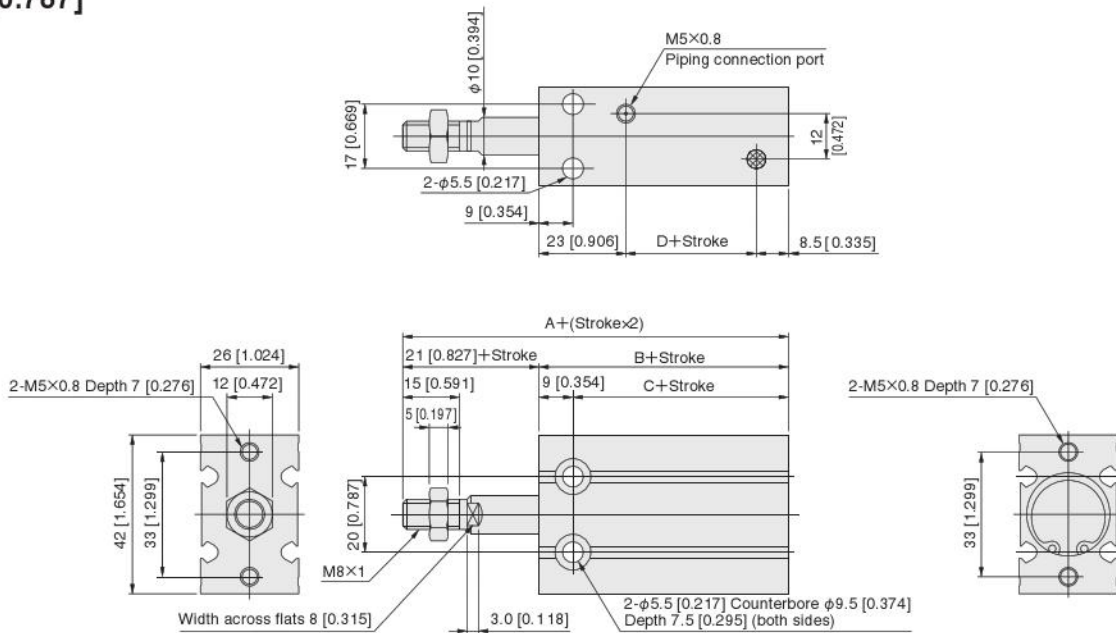

Type		Standard cylinder				Cylinder with sensor				mm [in.]						
Bore	Symbol	A	B	C	D	A	B	C	D	E	F	G	H	I	J	K
20	[0.787]	66 [2.598]	45 [1.772]	36 [1.417]	13.5 [0.531]	76 [2.992]	55 [2.165]	46 [1.811]	23.5 [0.925]	17 [0.669]	9 [0.354]	14 [0.551]	12 [0.472]	8 [0.315]	3.2 [0.126]	M5 × 0.8

High multi cylinder

Non-rotating cylinders



Symbol

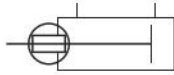

Specifications

Item	Cylinder bore	6 [0.236]	10 [0.394]	16 [0.630]	20 [0.787]
Operation type		Double acting type			
Media		Air			
Operating pressure range	Mpa [psi.]	0.2~0.7 [29~102]	0.15~0.7 [22~102]	0.1~0.7 [15~102]	
Proof pressure	Mpa [psi.]	1.05 [152]			
Operating temperature range	°C [°F]	0~60 [32~140]			
Operating speed range	mm/s [in/sec]	50~500 [2~20]			
Cushion		Rubber bumper			
Lubrication		Not required (if used, use turbine oil class 1 [ISO VG32] or equivalent)			
Port size		M5 × 0.8			
Non-rotating accuracy		± 0.8°			± 0.5°

Cylinder bore and stroke

Bore	Standard stroke	Maximum manufacturable stroke
6 [0.236]	5 · 10 · 15 · 20 · 25 · 30	30
10 [0.394]		
16 [0.630]		
20 [0.787]	5 · 10 · 15 · 20 · 25 · 30 · 40 · 50	50

Cylinder thrust

Cylinder bore mm [in.]	Piston rod diameter mm [in.]	Operation	Pressure area mm ² [in ²]	Air pressure Mpa [psi.]						
				0.1 [15]	0.2 [29]	0.3 [44]	0.4 [58]	0.5 [73]	0.6 [87]	0.7 [102]
6 [0.236]	3 [0.118]	Push side	28.2 [0.0437]	—	5.6 [1.26]	8.5 [1.91]	11.3 [2.54]	14.1 [3.17]	16.9 [3.80]	19.7 [4.43]
		Pull side	21.2 [0.0329]	—	4.2 [0.94]	6.4 [1.44]	8.5 [1.91]	10.6 [2.38]	12.7 [2.85]	14.8 [3.33]
10 [0.394]	5 [0.197]	Push side	78.5 [0.1217]	7.9 [1.78]	15.7 [3.53]	23.6 [5.31]	31.4 [7.06]	39.3 [8.83]	47.1 [10.59]	55 [12.36]
		Pull side	58.9 [0.0913]	5.9 [1.33]	11.8 [2.65]	17.7 [3.98]	23.6 [5.31]	29.5 [6.63]	35.3 [7.94]	41.2 [9.26]
16 [0.630]	6 [0.236]	Push side	201 [0.312]	20.1 [4.52]	40.2 [9.04]	60.3 [13.56]	80.4 [18.07]	100.5 [22.59]	120.6 [27.11]	140.7 [31.63]
		Pull side	172 [0.267]	17.2 [3.87]	34.4 [7.73]	51.6 [11.60]	68.8 [15.47]	86 [19.33]	103.2 [23.20]	120.4 [27.07]
20 [0.787]	10 [0.394]	Push side	314 [0.487]	31.4 [7.06]	62.8 [14.12]	94.2 [21.18]	125.6 [28.23]	157 [35.29]	188.4 [42.35]	219.8 [49.41]
		Pull side	235 [0.364]	23.5 [5.28]	47 [10.57]	70.5 [15.85]	94 [21.13]	117.5 [26.41]	141 [31.70]	164.5 [36.98]

Mass

Model	Stroke								Additional mass for sensor switch	
	5	10	15	20	25	30	40	50	ZE□□□A, ZE□□□G	ZE□□□B
YMDAL6 YMDALS6	31 [1.09] (31 [1.09])	31 [1.09] (34 [1.20])	34 [1.20] (37 [1.31])	37 [1.31] (40 [1.41])	40 [1.41] (43 [1.52])	43 [1.52] (46 [1.62])	—	—	15 [0.53]	35 [1.23]
YMDAL10 YMDALS10	41 [1.45] (42 [1.48])	40 [1.41] (46 [1.62])	44 [1.55] (50 [1.76])	48 [1.69] (54 [1.90])	52 [1.83] (58 [2.05])	56 [1.98] (62 [2.19])	—	—		
YMDAL16 YMDALS16	82 [2.89] (85 [3.00])	81 [2.86] (91 [3.21])	87 [3.07] (97 [3.42])	93 [3.28] (103 [3.63])	99 [3.49] (109 [3.84])	105 [3.70] (115 [4.06])	—	—		
YMDAL20 YMDALS20	154 [5.43] (182 [6.42])	167 [5.89] (195 [6.88])	180 [6.35] (208 [7.34])	193 [6.81] (221 [7.80])	206 [7.27] (234 [8.25])	219 [7.72] (247 [8.71])	245 [8.64] (273 [9.63])	271 [9.56] (299 [10.55])		

Note: Values in parentheses are for cylinder with magnet.

Non-rotating cylinder order code

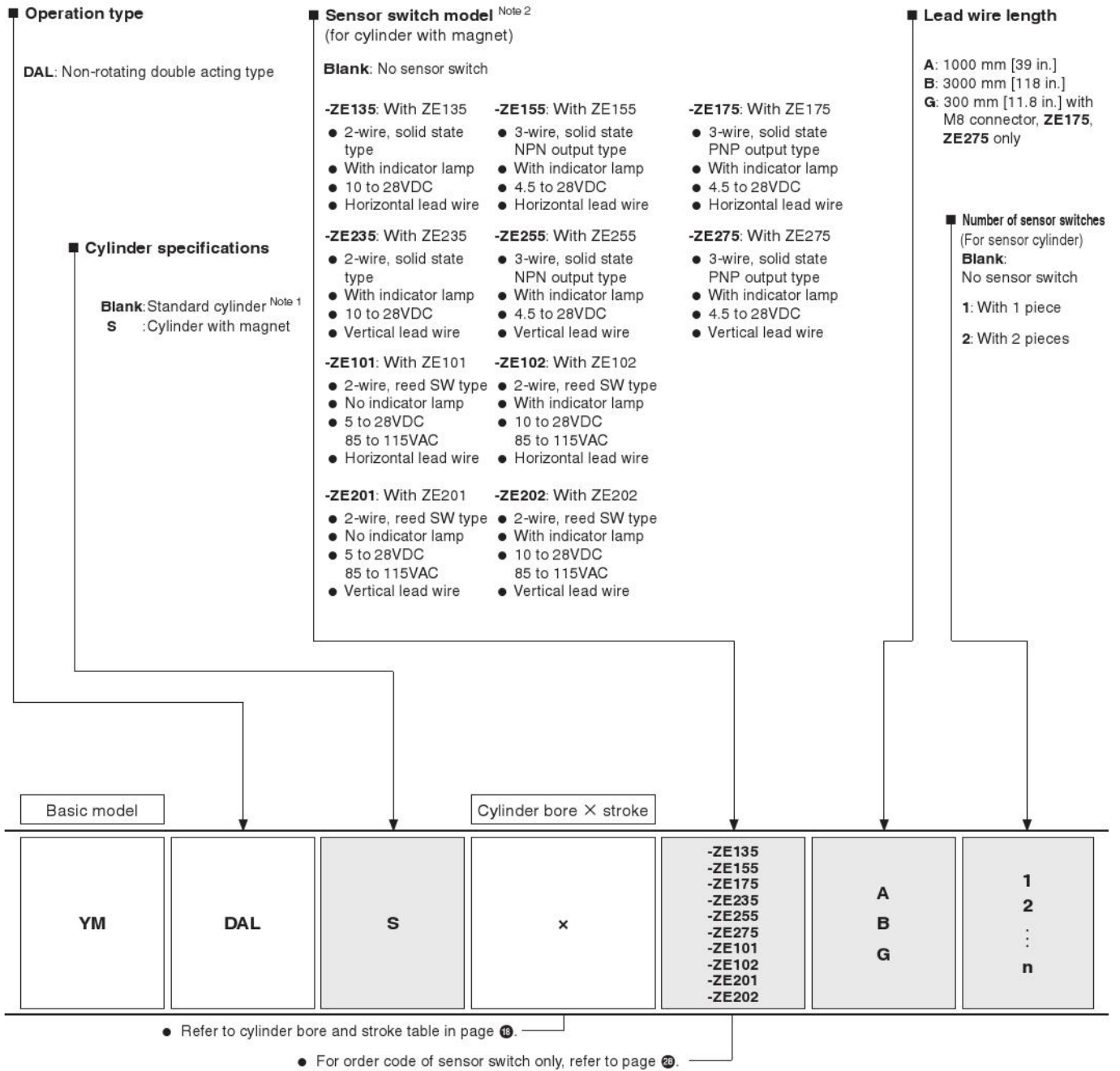

Note 1: The standard cylinder does not have built-in magnet for sensor switch.

2: For details of sensor switch, refer to page 27.

Inner construction

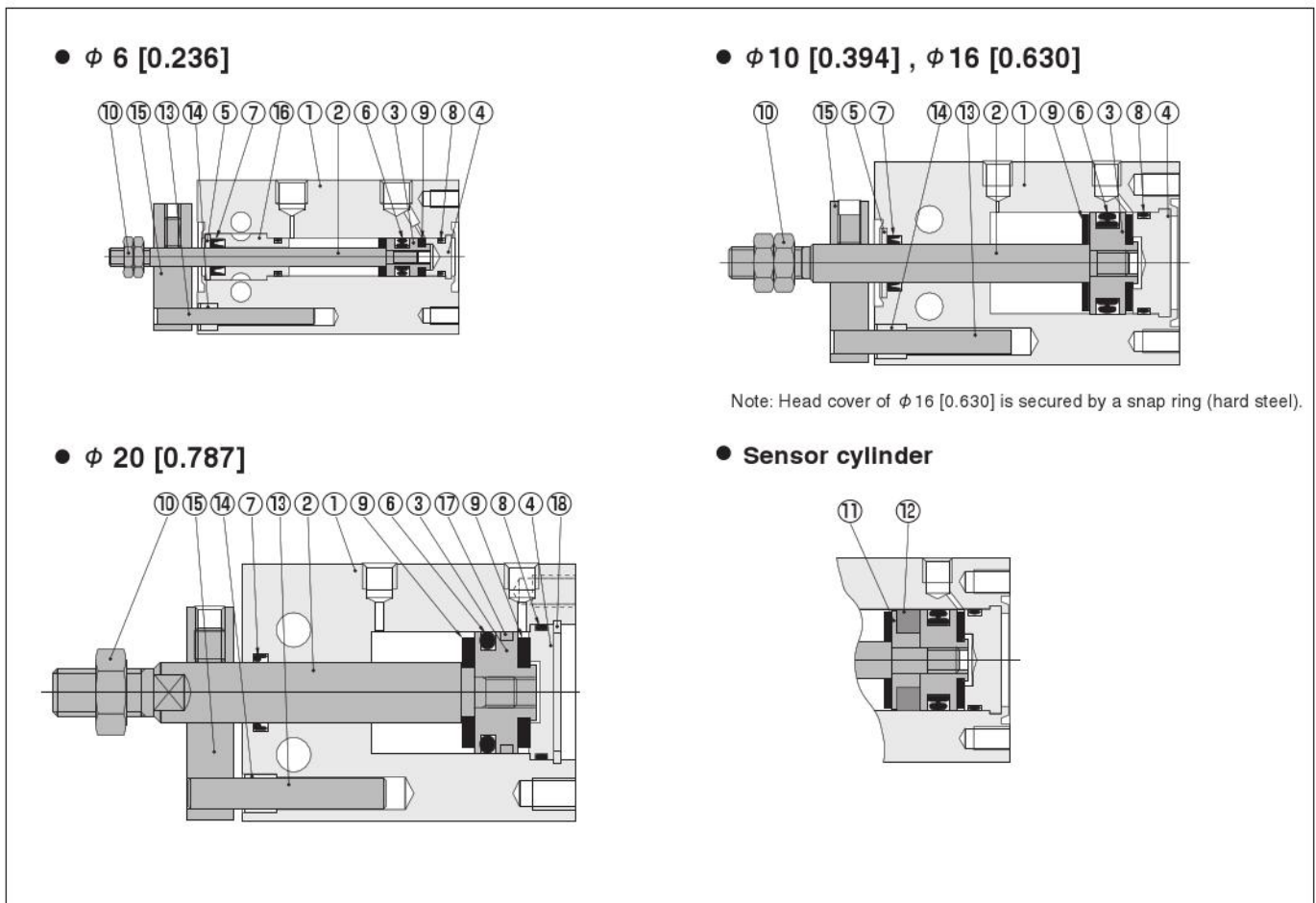

Parts names and major part materials

No	Name	Material
①	Cylinder body	Aluminum alloy (special anti-abrasion treated, anodized for $\phi 6$ [0.236] only)
②	Piston rod	Stainless steel (hard chrome plated for $\phi 20$ [0.787] only)
③	Piston	Brass (aluminum alloy for $\phi 20$ [0.787] only [special anti-rust treated])
④	Head cover	Aluminum alloy (special anti-rust treated)
⑤	Seal holder	Aluminum alloy (special anti-rust treated)
⑥	Piston seal	Synthetic rubber (NBR)
⑦	Rod seal	Synthetic rubber (NBR)
⑧	O-ring	Synthetic rubber (NBR)
⑨	Bumper	Synthetic rubber (NBR)
⑩	Rod end nut	Steel (nickel plated, zinc plated for $\phi 20$ [0.787] only)
⑪	Support	Brass (aluminum alloy for $\phi 20$ [0.787] only [special anti-rust treated])
⑫	Magnet	Plastic magnet
⑬	Guide pin	Stainless steel
⑭	Bushing	Aluminum alloy (special anti-abrasion treated)
⑮	Plate	Aluminum alloy (anodized)
⑯	Rod cover	Aluminum alloy (special anti-abrasion treated)
⑰	Wear ring	Plastic
⑱	Snap ring	Hard steel

List of seals used

Cylinder bore mm [in.]	Type	Non-rotating cylinder	
	Name	Rod seal	Piston seal
6 [0.236]		MYR-3	COP-6L
10 [0.394]		MYR-5	COP-10L
16 [0.630]		MYR-6	COP-16L
20 [0.787]		MYR-10	COP-20

Dimensions for non-rotating double acting type mm [in.]

YMDAL□ [Cylinder bore] × [Stroke]

- $\phi 6$ [0.236], $\phi 10$ [0.394], $\phi 16$ [0.630]

CAUTION Dimensions A to D for the stroke 5 mm [0.197 in.] of the standard cylinder are dimensions of the cylinder with magnet.

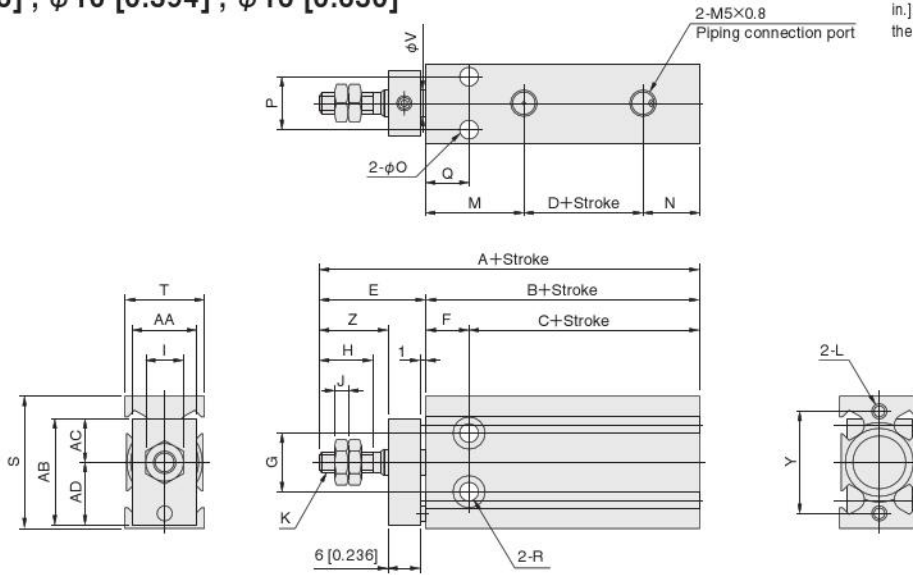

mm [in.]

Type Symbol	Standard cylinder <i>Note</i>				Cylinder with magnet				E	F	G	H	I	J	K
	A	B	C	D	A	B	C	D							
Bore 6 [0.236]	43 [1.693]	28 [1.102]	21 [0.827]	2 [0.079]	48 [1.890]	33 [1.299]	26 [1.024]	7 [0.276]	15 [0.591]	7 [0.276]	11 [0.433]	7 [0.276]	5.5 [0.217]	1.8 [0.071]	M3 × 0.5
10 [0.394]	53 [2.087]	31 [1.220]	23 [0.906]	2.5 [0.098]	58 [2.283]	36 [1.417]	28 [1.102]	7.5 [0.295]	22 [0.866]	8 [0.315]	11 [0.433]	10 [0.394]	7 [0.276]	2.4 [0.094]	M4 × 0.7
16 [0.630]	58 [2.283]	35 [1.378]	26 [1.024]	3 [0.118]	63 [2.480]	40 [1.575]	31 [1.220]	8 [0.315]	23 [0.906]	9 [0.354]	14 [0.551]	12 [0.472]	8 [0.315]	3.2 [0.126]	M5 × 0.8

Type Symbol	Bore	L	M	N	O	P	Q	R	S	T	V	Y	Z	AA	AB	AC	AD
10 [0.394]	M3 × 0.5 Depth 5 [0.197]	18 [0.709]	10.5 [0.413]	3.4 [0.134]	10 [0.394]	8 [0.315]	$\phi 3.4$ [0.134] C bore $\phi 6$ [0.236] Depth 5 [0.197] (both sides)	25 [0.984]	15 [0.591]	5 [0.197]	19 [0.748]	15 [0.591]	12 [0.472]	20 [0.787]	8 [0.315]	12 [0.472]	
16 [0.630]	M4 × 0.7 Depth 6 [0.236]	20 [0.787]	12 [0.472]	4.5 [0.177]	12 [0.472]	9 [0.354]	$\phi 4.5$ [0.177] C bore $\phi 7.6$ [0.299] Depth 6.5 [0.256] (both sides)	33 [1.299]	20 [0.787]	6 [0.236]	25 [0.984]	16 [0.630]	15 [0.591]	25 [0.984]	9.5 [0.374]	15.5 [0.610]	

Note: Dimensions A to D for the stroke 5 mm are dimensions of the cylinder with magnet.

- $\phi 20$ [0.787]

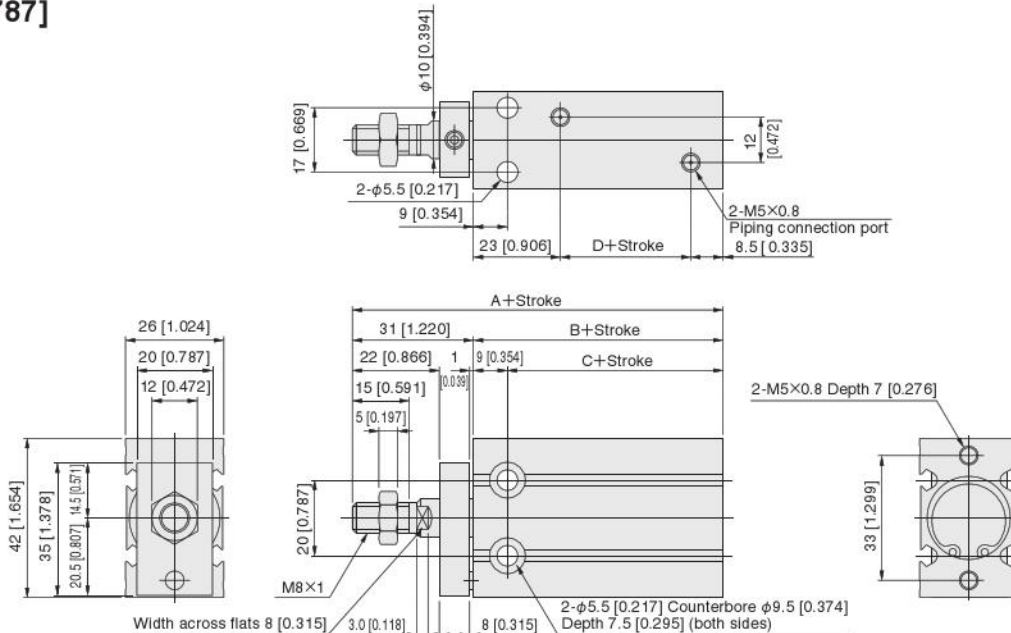

mm [in.]

Type Symbol	Standard cylinder				Cylinder with magnet			
	A	B	C	D	A	B	C	D
Bore 20 [0.787]	71 [2.795]	40 [1.575]	31 [1.220]	8.5 [0.335]	81 [3.189]	50 [1.969]	41 [1.614]	18.5 [0.728]

High multi cylinder

Cylinders with guides

Symbol

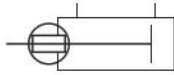

Specifications

Item	Cylinder bore	6 [0.236]	10 [0.394]	16 [0.630]	20 [0.787]
Operation type		Double acting type			
Media		Air			
Operating pressure range	MPa [psi.]	0.2~0.7 [29~102]	0.15~0.7 [22~102]	0.1~0.7 [15~102]	
Proof pressure	MPa [psi.]	1.05 [152]			
Operating temperature range	°C [°F]	0~60 [32~140]			
Operating speed range	mm/s [in/sec]	100~500 [4~20]	50~500 [2~20]		
Cushion		Rubber bumper			
Lubrication	Cylinder portion	Not required (if used, use turbine oil class 1 [ISO VG32] or equivalent)			
	Guide portion	Not required (if lubricated, use lithium-soap base grease)			
Port size		M5×0.8, M3×0.5 (in the case with rear piping base)			
Running parallelism	mm [in.]	0.1 [0.004]			
Allowable moment N · m [in · lbf]	Pitching	0.39 [3.45]		0.51 [4.51]	1.02 [9.03]
	Rolling	0.58 [5.13]		1.02 [9.03]	2.08 [18.41]
	Yawing	0.47 [4.16]		0.51 [4.51]	1.02 [9.03]

Cylinder bore and stroke

Bore	Standard stroke	Maximum manufacturable stroke
6 [0.236]	10 · 20 · 30 · 40 · 50 · 60	60
10 [0.394]		
16 [0.630]		
20 [0.787]		

Cylinder thrust

Cylinder bore mm [in.]	Piston rod diameter mm [in.]	Operation	Pressure area mm ² [in ²]	Air pressure Mpa [psi.]						
				0.1 [15]	0.2 [29]	0.3 [44]	0.4 [58]	0.5 [73]	0.6 [87]	0.7 [102]
6 [0.236]	3 [0.118]	Push side	28.2 [0.0437]	—	5.6 [1.26]	8.5 [1.91]	11.3 [2.54]	14.1 [3.17]	16.9 [3.80]	19.7 [4.43]
		Pull side	21.2 [0.0329]	—	4.2 [0.94]	6.4 [1.44]	8.5 [1.91]	10.6 [2.38]	12.7 [2.85]	14.8 [3.33]
10 [0.394]	5 [0.197]	Push side	78.5 [0.1217]	7.9 [1.78]	15.7 [3.53]	23.6 [5.31]	31.4 [7.06]	39.3 [8.83]	47.1 [10.59]	55 [12.36]
		Pull side	58.9 [0.0913]	5.9 [1.33]	11.8 [2.65]	17.7 [3.98]	23.6 [5.31]	29.5 [6.63]	35.3 [7.94]	41.2 [9.26]
16 [0.630]	6 [0.236]	Push side	201 [0.312]	20.1 [4.52]	40.2 [9.04]	60.3 [13.56]	80.4 [18.07]	100.5 [22.59]	120.6 [27.11]	140.7 [31.63]
		Pull side	172 [0.267]	17.2 [3.87]	34.4 [7.73]	51.6 [11.60]	68.8 [15.47]	86 [19.33]	103.2 [23.20]	120.4 [27.07]
20 [0.787]	10 [0.394]	Push side	314 [0.487]	31.4 [7.06]	62.8 [14.12]	94.2 [21.18]	125.6 [28.23]	157 [35.29]	188.4 [42.35]	219.8 [49.41]
		Pull side	235 [0.364]	23.5 [5.28]	47 [10.57]	70.5 [15.85]	94 [21.13]	117.5 [26.41]	141 [31.70]	164.5 [36.98]

Mass

Model	Stroke						Additional mass for sensor switch	
	10	20	30	40	50	60	ZE□□□A, ZE□□□G	ZE□□□B
YMDAGS6	50 [1.76]	59 [2.08]	68 [2.40]	77 [2.72]	86 [3.03]	95 [3.35]	15 [0.53]	35 [1.23]
YMDAGS10	66 [2.33]	77 [2.72]	88 [3.10]	99 [3.49]	110 [3.88]	121 [4.27]		
YMDAGS16	140 [4.94]	158 [5.57]	176 [6.21]	194 [6.84]	212 [7.48]	230 [8.11]		
YMDAGS20	273 [9.63]	307 [10.83]	341 [12.03]	375 [13.23]	409 [14.43]	443 [15.63]		

● With rear piping base

Model	Stroke						Additional mass for sensor switch	
	10	20	30	40	50	60	ZE□□□A, ZE□□□G	ZE□□□B
YMDAGS6 × □ -L	76 [2.68]	90 [3.17]	104 [3.67]	118 [4.16]	132 [4.66]	146 [5.15]	15 [0.53]	35 [1.23]
YMDAGS10 × □ -L	94 [3.32]	109 [3.84]	125 [4.41]	140 [4.94]	155 [5.47]	171 [6.03]		
YMDAGS16 × □ -L	186 [6.56]	211 [7.44]	235 [8.29]	260 [9.17]	284 [10.02]	309 [10.90]		
YMDAGS20 × □ -L	345 [12.17]	387 [13.65]	429 [15.13]	471 [16.61]	513 [18.10]	555 [19.58]		

Cylinder with guide order code

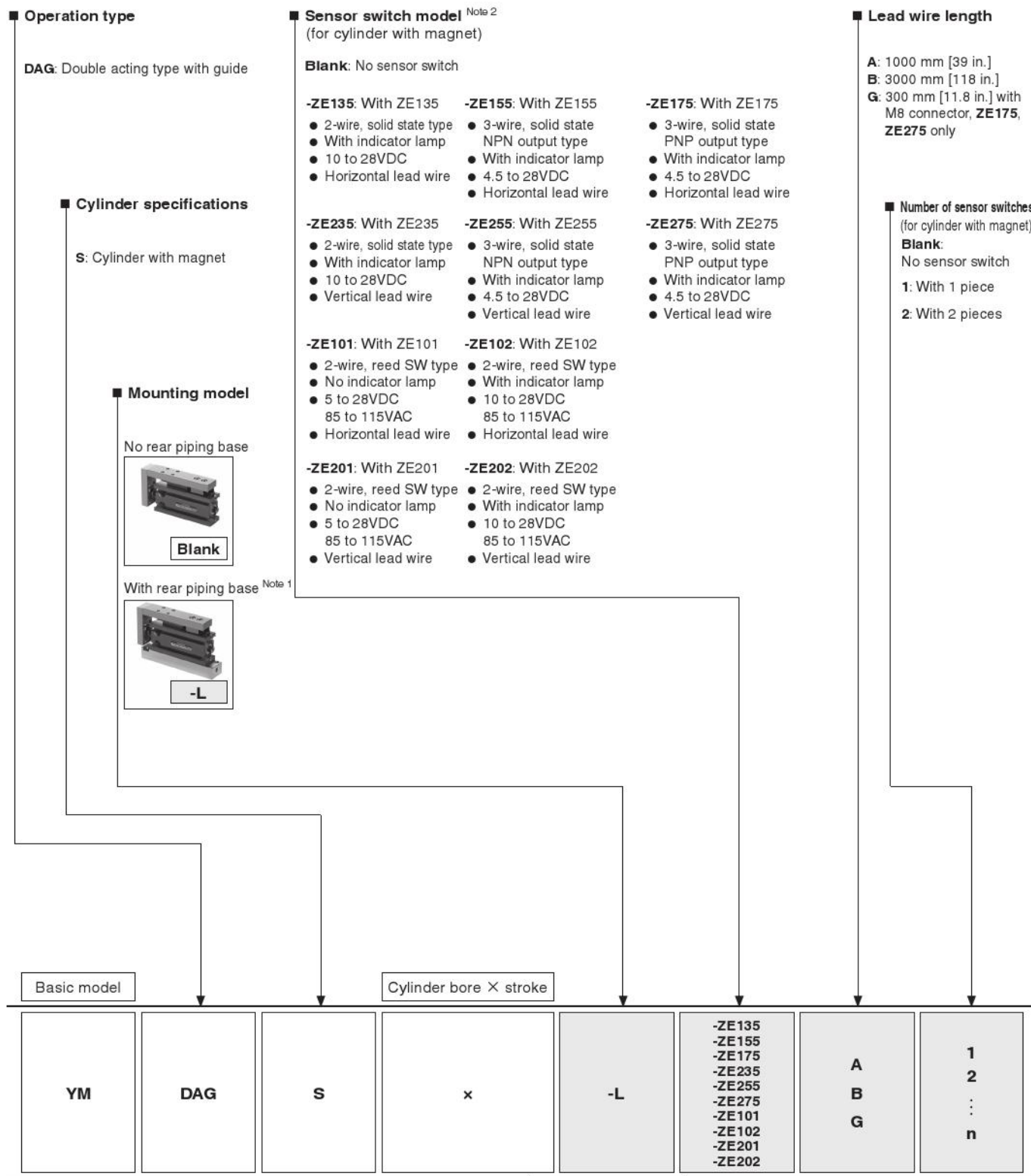

- Refer to cylinder bore and stroke table in page 20.
- For order code of sensor switch only, refer to page 21.

Note 1: Rear piping base is supplied with shipment.
 Note 2: For details of sensor switch, refer to page 21.

Additional parts (sold separately)



Order code example

L-YMDAGS [Cylinder bore] × [stroke]

- Rear piping base (with 2 mounting screws and 2 O-rings)

Inner construction

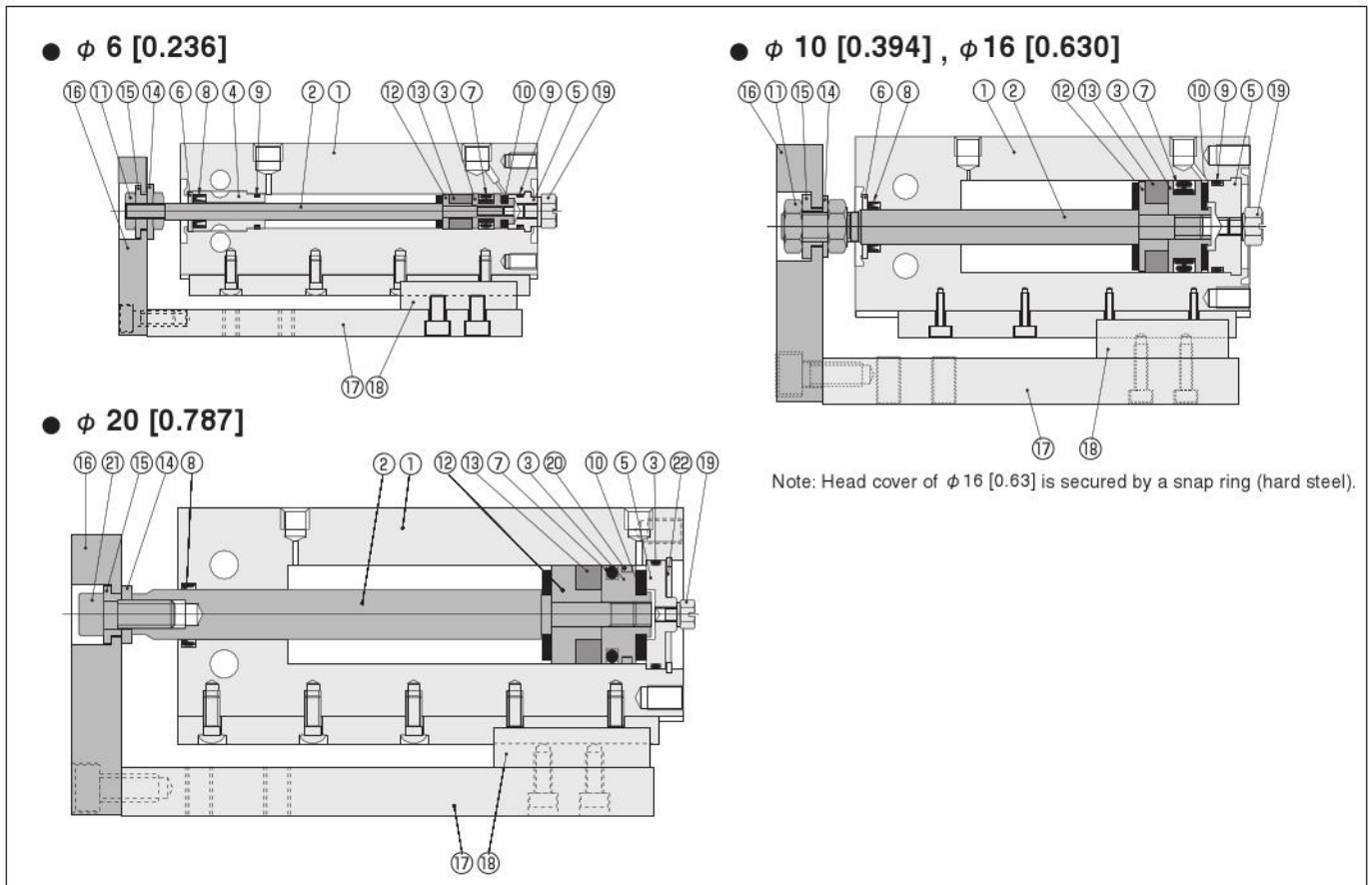

Parts names and major parts materials

No	Name	Material
①	Cylinder body	Aluminum alloy (special anti-abrasion treated, anodized for ϕ 6 [0.236] only)
②	Piston rod	Stainless steel (hard chrome plated for ϕ 20 [0.787] only)
③	Piston	Brass (aluminum alloy for ϕ 20 [0.787] only [special anti-rust treated])
④	Rod cover	Aluminum alloy (special anti-abrasion treated)
⑤	Head cover	Aluminum alloy (special anti-rust treated)
⑥	Seal holder	Aluminum alloy (special anti-rust treated)
⑦	Piston seal	Synthetic rubber (NBR)
⑧	Rod seal	Synthetic rubber (NBR)
⑨	O-ring	Synthetic rubber (NBR)
⑩	Bumper	Synthetic rubber (NBR)
⑪	Rod end nut	Steel (nickel plated)
⑫	Support	Brass (aluminum alloy for ϕ 20 [0.787] only [special anti-rust treated])
⑬	Magnet	Plastic magnet
⑭	Screw retainer	Hard steel (nickel plated)
⑮	Spacer	Hard steel (nickel plated)
⑯	Plate	Aluminum alloy (special anti-abrasion treated)
⑰	Table	Aluminum alloy (special anti-abrasion treated)
⑱	Linear guide	Stainless steel
⑲	Plug	Stainless steel
⑳	Wear ring	Plastic
㉑	Screw	Stainless steel
㉒	Snap ring	Hard steel

List of seals used

Cylinder bore mm [in.]	Type	Cylinder with guide	
	Name	Rod seal	Piston seal
6 [0.236]		MYR-3	COP-6L
10 [0.394]		MYR-5	COP-10L
16 [0.630]		MYR-6	COP-16L
20 [0.787]		MYR-10	COP-20

Dimensions for double acting type with guide mm [in.]

YMDAGS Cylinder bore × Stroke

- $\phi 6$ [0.236], $\phi 10$ [0.394], $\phi 16$ [0.630]

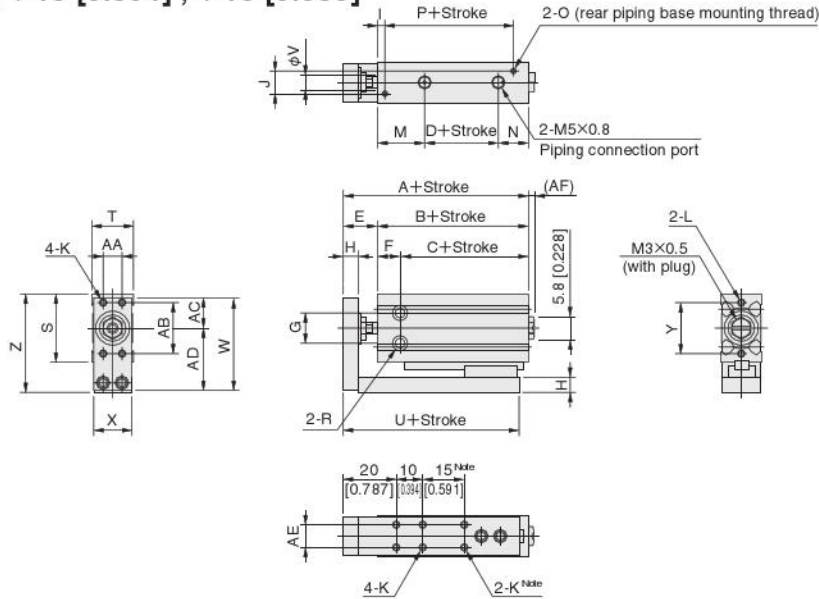

Note: Not available for $\phi 6$ [0.236] and $\phi 10$ [0.394] with strokes below 30, and $\phi 16$ [0.63] with strokes below 20.

mm [in.]

Symbol	A	B	C	D	E	F	G	H	I	J	K	L	M	N	O
6 [0.236]	44 [1.732]	33 [1.299]	26 [1.024]	7 [0.276]	11 [0.433]	7 [0.276]	11 [0.433]	5 [0.197]	2.5 [0.098]	8 [0.315]	M3 × 0.5	M3 × 0.5 Depth 5 [0.197]	15.5 [0.610]	10.5 [0.413]	M3 × 0.5
10 [0.394]	49 [1.929]	36 [1.417]	28 [1.102]	7.5 [0.295]	13 [0.512]	8 [0.315]	11 [0.433]	6 [0.236]	3 [0.118]	8 [0.315]	M3 × 0.5	M3 × 0.5 Depth 5 [0.197]	18 [0.709]	10.5 [0.413]	M3 × 0.5
16 [0.630]	54 [2.126]	40 [1.575]	31 [1.220]	8 [0.315]	14 [0.551]	9 [0.354]	14 [0.551]	8 [0.315]	5 [0.197]	12 [0.472]	M4 × 0.7	M4 × 0.7 Depth 6 [0.236]	20 [0.787]	12 [0.472]	M4 × 0.7

Symbol	P	R	S	T	U	V	W	X	Y	Z	AA	AB	AC	AD	AE	AF
6 [0.236]	25.5 [1.004]	$\phi 3.4$ [0.134] Counterbore $\phi 6$ [0.236] Depth 5 [0.197] (both sides)	24 [0.945]	13 [0.512]	41 [1.614]	3 [0.118]	32 [1.260]	12 [0.472]	19 [0.748]	34.5 [1.358]	6 [0.236]	14 [0.551]	9.5 [0.374]	22.5 [0.886]	6 [0.236]	3.6 [0.142]
10 [0.394]	28 [1.102]	$\phi 3.4$ [0.134] Counterbore $\phi 6$ [0.236] Depth 5 [0.197] (both sides)	25 [0.984]	15 [0.591]	46 [1.811]	5 [0.197]	35 [1.378]	14 [0.551]	19 [0.748]	36.5 [1.437]	7 [0.276]	16 [0.630]	11 [0.433]	24 [0.945]	8 [0.315]	2.4 [0.094]
16 [0.630]	30 [1.181]	$\phi 4.5$ [0.177] Counterbore $\phi 7.8$ [0.299] Depth 6.5 [0.256] (both sides)	33 [1.299]	20 [0.787]	52 [2.047]	6 [0.236]	46 [1.811]	19 [0.748]	25 [0.984]	48 [1.890]	10 [0.394]	20 [0.787]	14.5 [0.571]	31.5 [1.240]	10 [0.394]	2.4 [0.094]

- $\phi 20$ [0.787]

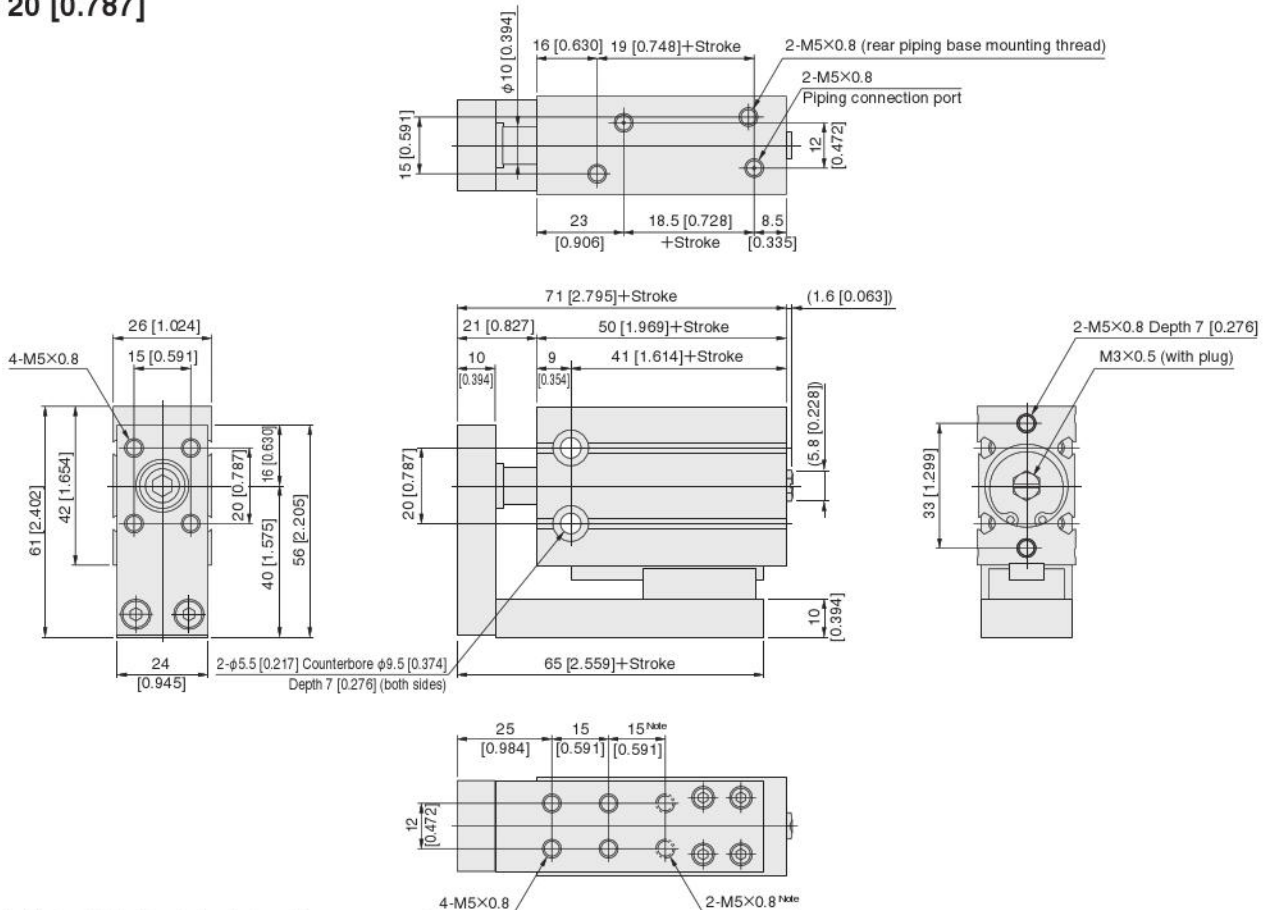

Note: Not available for strokes below 20.

Dimensions for double acting type with guide (with rear piping base) mm [in.]

YMDAGS [Cylinder bore] × [Stroke] -L

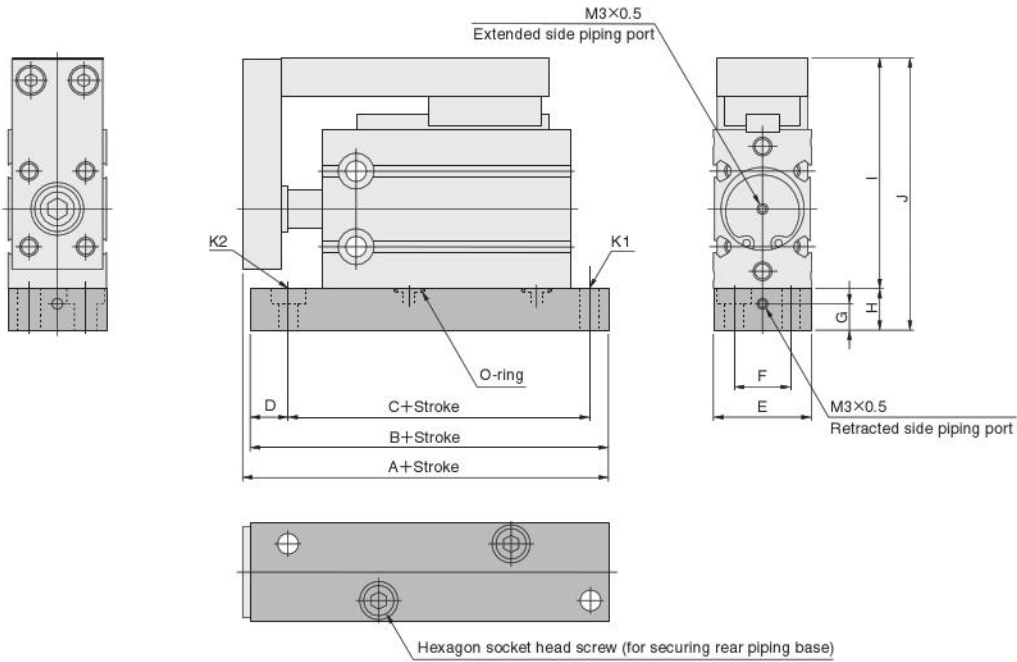

Note: Rear piping base, 2 hexagon socket head screws (for securing rear piping base) and 2 O-rings are included with shipment.

													mm [in.]	
Bore	Symbol	A	B	C	D	E	F	G	H	I	J	K1	K2	
6	[0.236]	51 [2.008]	49 [1.929]	41 [1.614]	5 [0.197]	15 [0.591]	9 [0.354]	6 [0.236]	10.5 [0.413]	34.5 [1.358]	45 [1.772]	φ3.4 [0.134]	φ3.4 [0.134] Counterbore φ6 [0.236] Depth 2.5 [0.098]	
10	[0.394]	56 [2.205]	52 [2.047]	44 [1.732]	5 [0.197]	15 [0.591]	9 [0.354]	6 [0.236]	10.5 [0.413]	36.5 [1.437]	47 [1.850]	φ3.4 [0.134]	φ3.4 [0.134] Counterbore φ6 [0.236] Depth 2.5 [0.098]	
16	[0.630]	63 [2.480]	61 [2.402]	51 [2.008]	6 [0.236]	21 [0.827]	12 [0.472]	7 [0.276]	11 [0.433]	48 [1.890]	59 [2.323]	φ4.5 [0.177]	φ4.5 [0.177] Counterbore φ7.5 [0.295] Depth 4.4 [0.173]	
20	[0.787]	81 [3.189]	79 [3.110]	64 [2.520]	10 [0.394]	26 [1.024]	15 [0.591]	7 [0.276]	11 [0.433]	61 [2.402]	72 [2.835]	φ5.5 [0.217]	φ5.5 [0.217] Counterbore φ9.5 [0.374] Depth 5.4 [0.213]	

● Single rear piping base

L-YMDAGS [Cylinder bore] × [Stroke]

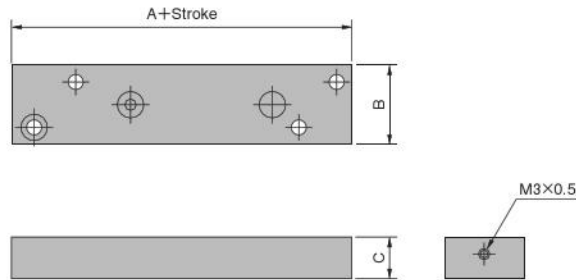

				mm [in.]		
Cylinder bore	Symbol	A	B	C		
6	[0.236]	49 [1.929]	15 [0.591]	10.5 [0.413]		
10	[0.394]	52 [2.047]	15 [0.591]	10.5 [0.413]		
16	[0.630]	61 [2.402]	21 [0.827]	11 [0.433]		
20	[0.787]	79 [3.110]	26 [1.024]	11 [0.433]		

High multi cylinder Sensor switches

Solid state type, reed switch type



Symbol

- Double acting type
- Single acting push type
- Single acting pull type
- Non-rotating double acting type / double acting type with guide



Specifications

● Solid state type

Item \ Model	ZE135□	ZE155□	ZE175□	ZE235□	ZE255□	ZE275□
Wiring type	2-lead wire	3-lead wire NPN output	3-lead wire PNP output	2-lead wire	3-lead wire NPN output	3-lead wire PNP output
Lead wire direction	Horizontal			Vertical		
Power supply voltage	—	4.5 to 28VDC		—	4.5 to 28VDC	
Load voltage	10 to 28VDC		4.5 to 28VDC	10 to 28VDC		4.5 to 28VDC
Load current	4 to 20 mA (at 25°C [77°F], 10 mA at 60°C [140°F])		50 mA MAX.	4 to 20 mA (at 25°C [77°F], 10 mA at 60°C [140°F])		50 mA MAX.
Consumption current	—	8 mA MAX. (24VDC)	10 mA MAX. (24VDC)	—	8 mA MAX. (24VDC)	10 mA MAX. (24VDC)
Internal voltage drop ^{Note 1}	4V MAX.		0.5V MAX. (at 20 mA for voltage below 10V)	4V MAX.		0.5V MAX. (at 20 mA for voltage below 10V)
Leakage current	0.7 mA MAX. (24VDC, 25°C [77°F])		50µA MAX. (24VDC)	0.7 mA MAX. (24VDC, 25°C [77°F])		50µA MAX. (24VDC)
Response time	1 ms MAX.					
Insulation resistance	100 MΩ MIN. (at 500VDC megger, between case and lead wire terminal)					
Dielectric strength	500VAC (50/60 Hz) 1 minute (between case and lead wire terminal)					
Shock resistance ^{Note 2}	294.2 m/s ² [30 G] (non-repeated shock)					
Vibration resistance ^{Note 2}	88.3 m/s ² [9 G] (total amplitude 1.5 mm [0.059 in.], 10 to 55 Hz)					
Environmental protection	IP67 (IEC standard), JIS C0920 (water-proof type)					
Operation indicator	When ON, red LED indicator lights up					
Lead wire	PCCV0.2SQ × 2-leads (brown, blue) × ℓ ^{Note 3}		PCCV0.15SQ × 3-leads (brown, blue, black) × ℓ ^{Note 3}	PCCV0.2SQ × 2-leads (brown, blue) × ℓ ^{Note 3}		PCCV0.15SQ × 3-leads (brown, blue, black) × ℓ ^{Note 3}
Ambient temperature	0~60°C [32~140°F]					
Storage temperature range	-10~70°C [14~158°F]					
Mass	15 g [0.53 oz.] (lead wire length A: 1000 mm [39 in.]), 35 g [1.23 oz.] (lead wire length B: 3000 mm [118 in.]), 15 g [0.53 oz.] (lead wire length 300 mm [11.8 in.] with M8 connector)					

Note 1: Internal voltage drop varies depending on load current.

2: Measured by Koganei test standards.

3: Lead wire length ℓ : A; 1000 mm [39 in.], B; 3000 mm [118 in.], G; 300 mm [11.8 in.] with M8 connector, ZE175□, ZE275□ only

● Reed switch type

Item \ Model	ZE101□		ZE102□		ZE201□		ZE202□	
Wiring type	2-lead wire							
Lead wire direction	Horizontal				Vertical			
Load voltage	5 to 28VDC	85 to 115VAC (r.m.s)	10 to 28VDC	85 to 115VAC (r.m.s)	5 to 28VDC	85 to 115VAC (r.m.s)	10 to 28VDC	85 to 115VAC (r.m.s)
Load current	40 mA MAX.	20 mA MAX.	5 to 40 mA	5 to 20 mA	40 mA MAX.	20 mA MAX.	5 to 40 mA	5 to 20 mA
Internal voltage drop ^{Note 1}	0.1 V MAX. (at load current of DC 40 mA)		3.0V MAX.		0.1 V MAX. (at load current of DC 40 mA)		3.0V MAX.	
Leakage current	0 mA							
Response time	1 ms MAX.							
Insulation resistance	100 MΩ MIN. (at 500VDC megger, between case and lead wire terminal)							
Dielectric strength	1500VAC (50/60 Hz) 1 minute (between case and lead wire terminal)							
Shock resistance ^{Note 2}	294.2 m/s ² [30 G] (non-repeated shock)							
Vibration resistance ^{Note 2}	88.3 m/s ² [9 G] (total amplitude 1.5 mm [0.059 in.], 10 to 55 Hz, resonance frequency 2570±250 Hz)							
Environmental protection	IP67 (IEC standard), JIS C0920 (water-proof type)							
Operation indicator	None		When ON, red LED indicator lights up		None		When ON, red LED indicator lights up	
Lead wire	PCCV0.2SQ × 2-leads (brown, blue) × ℓ ^{Note 3}							
Ambient temperature	0~60°C [32~140°F]							
Storage temperature range	-10~70°C [14~158°F]							
Contact protection	Required (Refer to contact protection countermeasure described in page 29)							
Mass	15 g [0.53 oz.] (lead wire length A: 1000 mm [39 in.]), 35 g [1.23 oz.] (lead wire length B: 3000 mm [118 in.])							

Note 1: Internal voltage drop varies depending on load current.

2: Measured by Koganei test standards.

3: Lead wire length ℓ : A; 1000 mm [39 in.], B; 3000 mm [118 in.]

Order code

- YMDAS

- Lead wire length
A: 1000 mm [39 in.]
B: 3000 mm [118 in.]
G: 300 mm [11.8 in.] with M8 connector, **ZE175**, **ZE275** only

Sensor switch model

ZE135 : Solid state type, 2-lead wire	With indicator lamp, 10 to 28V DC	Horizontal lead wire	ZE101 : Reed switch type, no indicator lamp	5 to 28VDC	Horizontal lead wire
ZE155 : Solid state type, 3-lead wire NPN output type	With indicator lamp, 4.5 to 28V DC	Horizontal lead wire		85 to 115VAC	
ZE175 : Solid state type, 3-lead wire PNP output type	With indicator lamp, 4.5 to 28V DC	Horizontal lead wire	ZE102 : Reed switch type, with indicator lamp	10 to 28VDC	Horizontal lead wire
ZE235 : Solid state type, 2-lead wire	With indicator lamp, 10 to 28V DC	Vertical lead wire		85 to 115VAC	
ZE255 : Solid state type, 3-lead wire NPN output type	With indicator lamp, 4.5 to 28V DC	Vertical lead wire	ZE201 : Reed switch type, no indicator lamp	5 to 28VDC	Vertical lead wire
ZE275 : Solid state type, 3-lead wire PNP output type	With indicator lamp, 4.5 to 28V DC	Vertical lead wire		85 to 115VAC	
			ZE202 : Reed switch type, with indicator lamp	10 to 28VDC	Vertical lead wire
				85 to 115VAC	

Internal circuit diagram

● Solid state type

● ZE135□, ZE235□

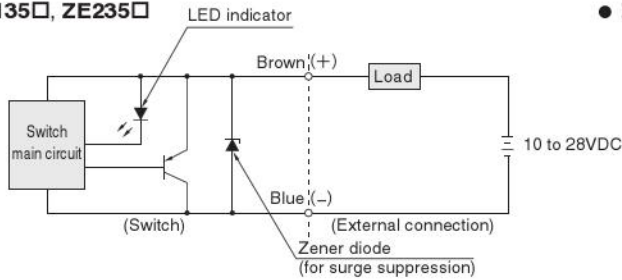

● ZE155□, ZE255□

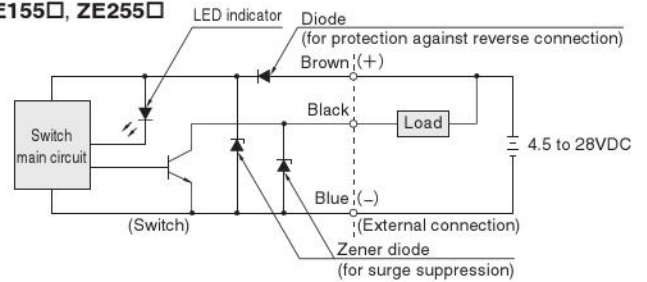

● ZE175□, ZE275□

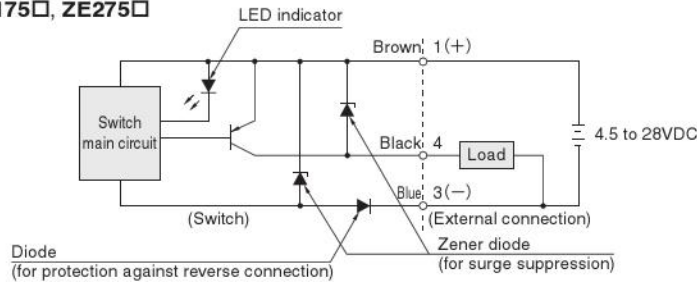

● Reed switch type

● ZE101□, ZE201□

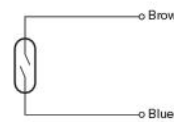

● ZE102□, ZE202□

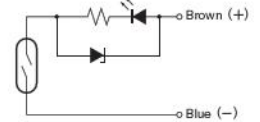

Dimensions for sensor switch mm [in.]

● Horizontal lead wire

● Solid state type (ZE135□, ZE155□, ZE175□)

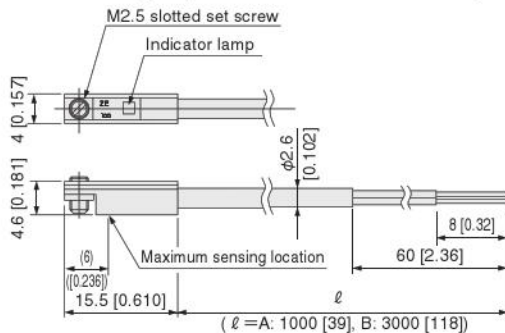

● Reed switch type (ZE101□, ZE102□)

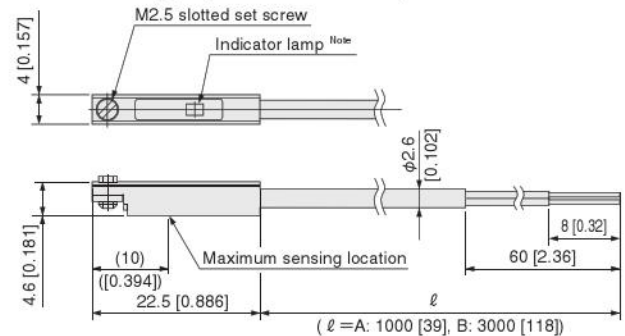

● Solid state type (ZE175G)

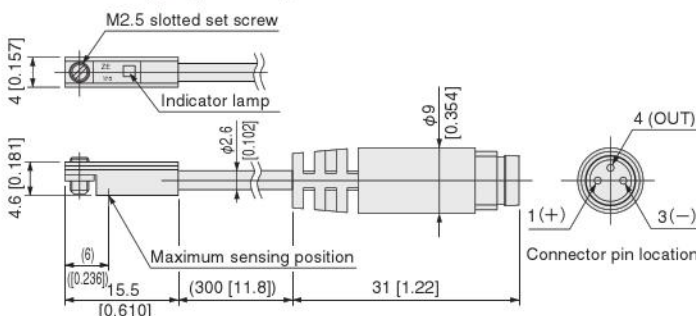

Note: Not available for **ZE101□**.

Dimensions for sensor switch mm [in.]

● Vertical lead wire

● Solid state type (ZE235□, ZE255□, ZE275□)

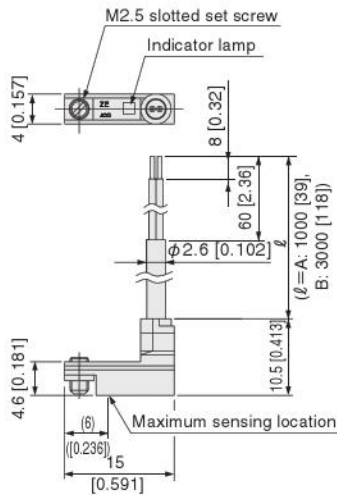

● Reed switch type (ZE201□, ZE202□)

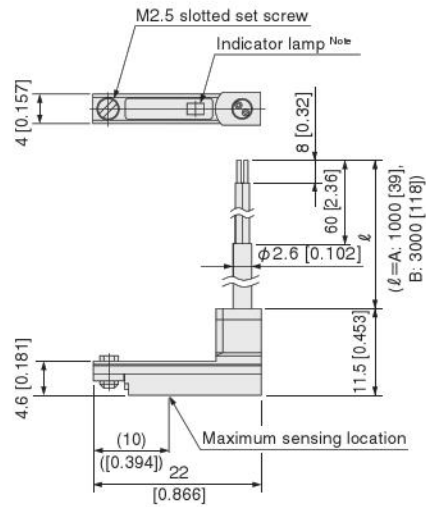

Note: Not available for ZE201.

● Solid state type (ZE275G)

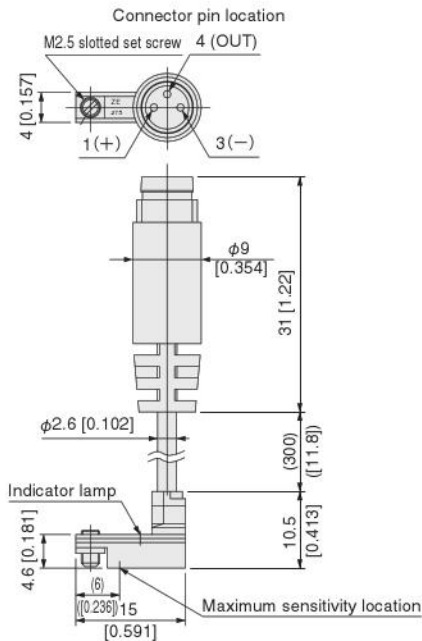

Contact protection countermeasure for reed switch type sensor switch

For stable use of reed switch type sensor switches, take the contact protection countermeasure below.

- In the case of connecting inductive load (electromagnetic relay, etc.)
- In the case of capacitive surge generated (when lead wire length exceeds 10 m [32.8 ft])

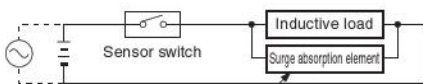

In the case of DC: Diode or CR, etc.

In the case of AC: CR, etc.

Diode: More than the circuit current for the forward current, and dielectric strength of more than 10 times the circuit voltage for the reverse direction.

C: 0.01 to 0.1 μ F
R: 1 to 4 k Ω

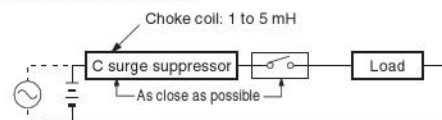

Wiring instructions for solid state type sensor switch

● 2-lead wire type

● Basic connection

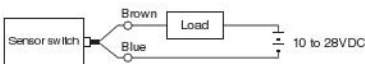

● Connection with relay

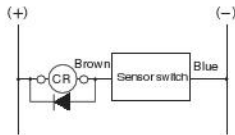

AND (serial) connection, OR (parallel) connection

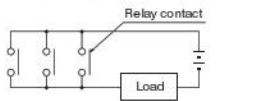
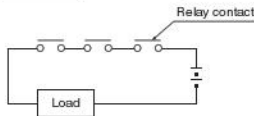
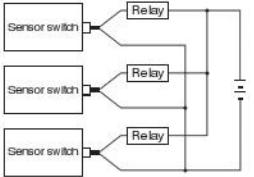

● Connection with solenoid valve

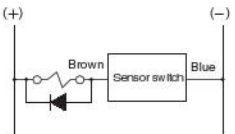

● Connection with programmable controller

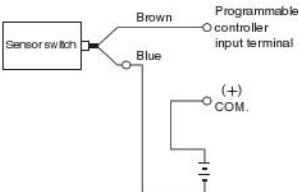

● 3-lead wire NPN output type

● Basic connection

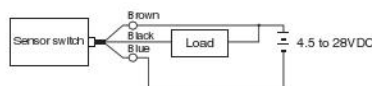

● Connection with relay

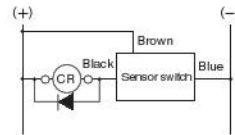

AND (serial) connection, OR (parallel) connection

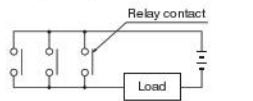
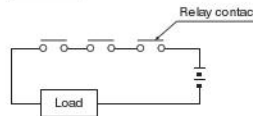
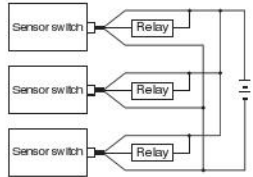

● Connection with solenoid valve

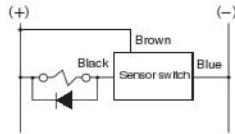

● Connection with programmable controller

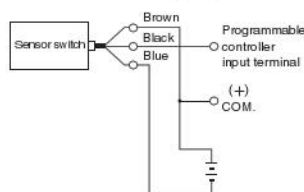

● 3-lead wire PNP output type

● Basic connection

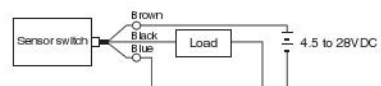

● Connection with relay

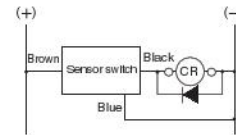

AND (serial) connection, OR (parallel) connection

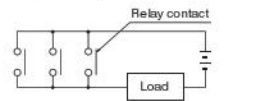
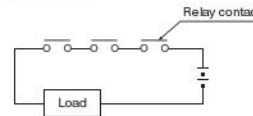
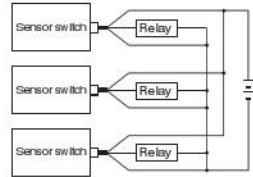

● Connection with solenoid valve

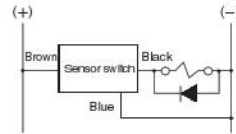

● Connection with programmable controller

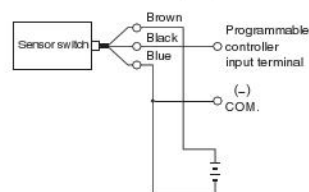

1. Follow wire color code for proper connection. Since there is no overcurrent protection, improper wiring will break the sensor switch.
2. For inductive load such as electromagnetic relay, etc., it is recommended to use surge protective diode.
3. Since the circuit voltage drops in proportion to the number of sensor switches, avoid using AND (serial) connection.
4. When using OR (parallel) connection, direct connection of sensor switch outputs (black wires, for example) is possible. But, the leakage current increases proportionally by the number of sensor switches. Therefore, be cautious against load return failure.

5. Avoid use in places where external magnetic field is strong, or near large current such as power lines, as the sensor switch is magnetic induction type. And, magnetic material should not be used in the mounting portion. This may cause erratic operations.
6. Do not apply excessive force by pulling the lead wire forcibly, or bending it excessively.
7. Avoid use in environment where it may be exposed to chemically active agents or gasses, etc.
8. For use in atmosphere where it may be exposed to water or oil, consult your nearest KOGANEI sales office.

Usable minimum cylinder stroke for sensor switch

Cylinder bore	mm [in.]			
	Solid state type		Reed switch type	
	2 pieces mounted	1 piece mounted	2 pieces mounted	1 piece mounted
6 [0.236]	5 [0.197]	5 [0.197]	10 [0.394]	5 [0.197]
10 [0.394]				
16 [0.630]	10 [0.394]	5 [0.197]	10 [0.394]	5 [0.197]
20 [0.787]				

Note: For mounting 2 sensor switches to the stroke 5 mm [0.197 in.] of $\phi 16$ [0.630] and $\phi 20$ [0.787], consult us.

Moving procedure of sensor switch

- The sensor switch can be moved along with the sensor switch mounting groove on the cylinder body by loosening the mounting screw.
- Tightening torque of mounting screw should be about 0.1 N·m to 0.2 N·m [0.9 to 1.8 in·lbf].

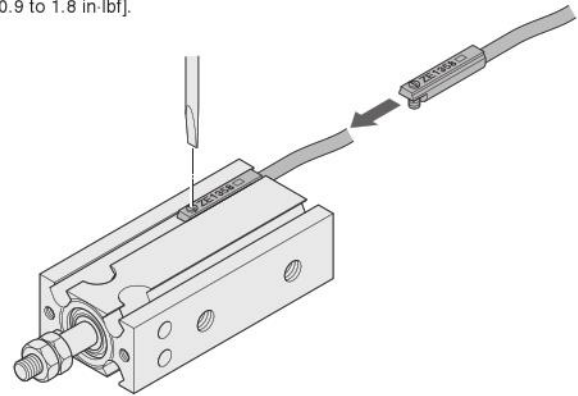

Sensor switch operation range, response differential, and maximum sensing position

• Operation range: ℓ

This is the range after the piston moves and the sensor switch is turned ON until it is turned OFF.

• Response differential: C

This is the distance between the position where the piston moves and turns the sensor switch ON and the position where the piston moves in opposite direction and the switch is turned OFF.

• Solid state type

Item	mm [in.]			
Bore	6 [0.236]	10 [0.394]	16 [0.630]	20 [0.787]
Operating range: ℓ	2.1 ~ 3.0 [0.083 ~ 0.118]	2.6 ~ 3.6 [0.102 ~ 0.142]	4.0 ~ 5.2 [0.157 ~ 0.205]	4.0 ~ 5.5 [0.157 ~ 0.217]
Response differential: C	1.0 [0.039] or lower			
Maximum sensing location ¹⁾	6 [0.236]			

Remark: The table above shows reference values.

Note: Values measured from opposite side of the lead wire.

• Reed switch type

Item	mm [in.]			
Bore	6 [0.236]	10 [0.394]	16 [0.630]	20 [0.787]
Operating range: ℓ	4.0 ~ 6.8 [0.157 ~ 0.268]	5.5 ~ 8.4 [0.217 ~ 0.331]	6.8 ~ 9.8 [0.268 ~ 0.386]	5.3 ~ 9.8 [0.209 ~ 0.386]
Response differential: C	1.0 [0.039] or lower			
Maximum sensing location ¹⁾	10 [0.394]			

Remark: The table above shows reference values.

Note: Values measured from opposite side of the lead wire.

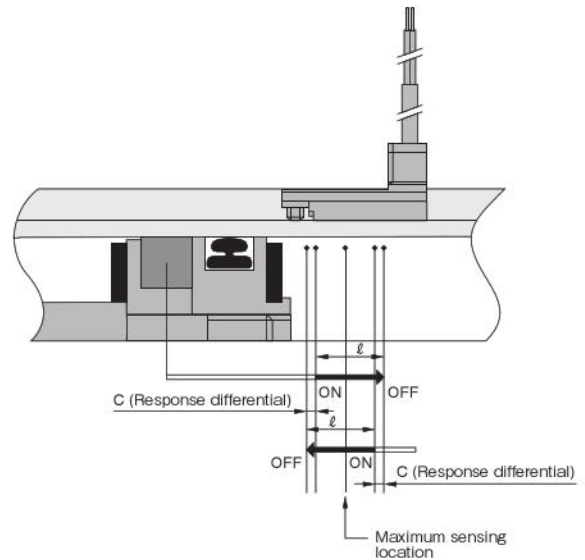

When the sensor switch is mounted in proximity

When mounting cylinders in close proximity, install them using a value higher than those indicated in the table below.

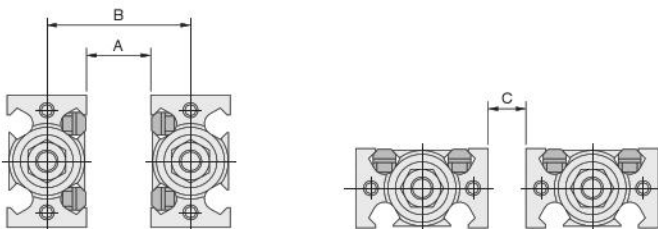

Bore	mm [in.]		
	A	B	C
6 [0.236]	8 [0.315]	21 [0.827]	0
10 [0.394]	20 [0.787]	35 [1.378]	12 [0.472]
16 [0.630]	15 [0.591]	35 [1.378]	4 [0.157]
20 [0.787]	12 [0.472]	38 [1.496]	0

Sensor switch mounting position for stroke end detection

When the sensor switch is mounted at the position specified in the following diagram (values in the table are reference values), the magnet moves to the maximum sensing location position of the sensor switch at the stroke end.

- Double acting type
- Single acting push type
- Single acting pull type

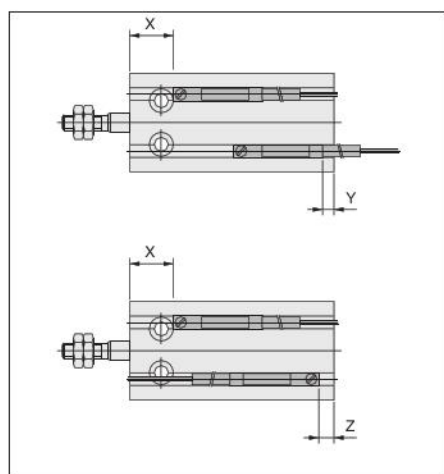

Operation type	Type Bore	Solid state type				Reed switch type			
		6 [0.236]	10 [0.394]	16 [0.630]	20 [0.787]	6 [0.236]	10 [0.394]	16 [0.630]	20 [0.787]
Double acting type	X	13 [0.512]	15 [0.591]	17 [0.669]	25 [0.984]	9 [0.354]	11 [0.433]	13 [0.512]	21 [0.827]
	Y	4.5 [0.177]	5.5 [0.217]	7.5 [0.295]	9.5 [0.374]	1.5 [0.059]	2.5 [0.098]	4.5 [0.177]	6.5 [0.256]
	Z	8 [0.315]	9 [0.354]	11 [0.433]	13 [0.512]	4 [0.157]	5 [0.197]	7 [0.276]	9 [0.354]
Single acting push type	X	18 [0.709]	20 [0.787]	22 [0.866]	30 [1.181]	14 [0.551]	16 [0.630]	18 [0.709]	26 [1.024]
	Y	4.5 [0.177]	5.5 [0.217]	7.5 [0.295]	9.5 [0.374]	1.5 [0.059]	2.5 [0.098]	4.5 [0.177]	6.5 [0.256]
	Z	8 [0.315]	9 [0.354]	11 [0.433]	13 [0.512]	4 [0.157]	5 [0.197]	7 [0.276]	9 [0.354]
Single acting pull type	X	13 [0.512]	15 [0.591]	17 [0.669]	25 [0.984]	9 [0.354]	11 [0.433]	13 [0.512]	21 [0.827]
	Y	9.5 [0.374]	10.5 [0.413]	12.5 [0.492]	14.5 [0.571]	6.5 [0.256]	7.5 [0.295]	9.5 [0.374]	11.5 [0.453]
	Z	13 [0.512]	14 [0.551]	16 [0.630]	18 [0.709]	9 [0.354]	10 [0.394]	12 [0.472]	14 [0.551]

- Non-rotating double acting type

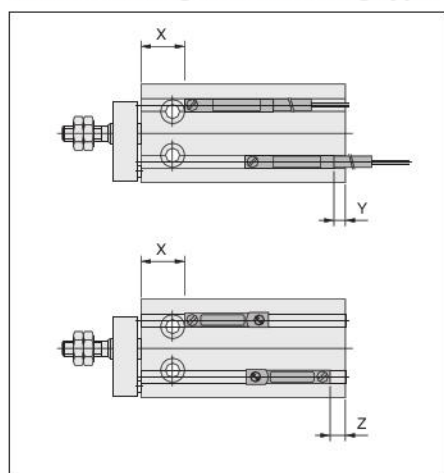

Operation type	Type Bore	Non-contact type				Contact type			
		6 [0.236]	10 [0.394]	16 [0.630]	20 [0.787]	6 [0.236]	10 [0.394]	16 [0.630]	20 [0.787]
Non-rotating double acting type	X	13 [0.512]	15 [0.591]	17 [0.669]	25 [0.984]	9 [0.354]	11 [0.433]	13 [0.512]	21 [0.827]
	Y	4.5 [0.177]	5.5 [0.217]	7.5 [0.295]	9.5 [0.374]	1.5 [0.059]	2.5 [0.098]	4.5 [0.177]	6.5 [0.256]
	Z	8 [0.315]	9 [0.354]	11 [0.433]	13 [0.512]	4 [0.157]	5 [0.197]	7 [0.276]	9 [0.354]

CAUTION: Avoid using the horizontal lead wire sensor switch inserting from the rod side of the non-rotating double acting type.

Failure to do so may cause interference with the plate and results in damaging the lead wire. Be sure to use the vertical lead wire sensor switch.

- Double acting type with guide

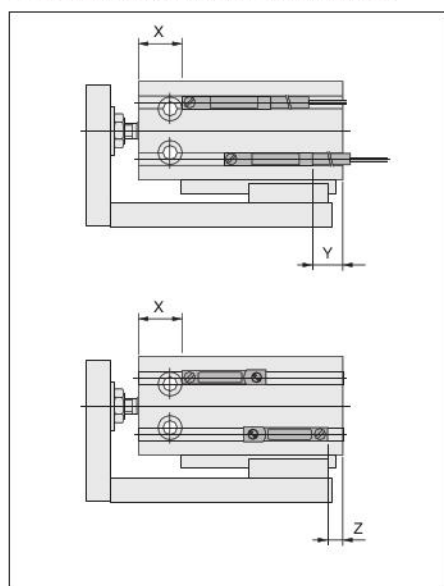

Operation type	Type Bore	Solid state type				Reed switch type			
		6 [0.236]	10 [0.394]	16 [0.630]	20 [0.787]	6 [0.236]	10 [0.394]	16 [0.630]	20 [0.787]
Double acting type with guide	X	13 [0.512]	15 [0.591]	17 [0.669]	25 [0.984]	9 [0.354]	11 [0.433]	13 [0.512]	21 [0.827]
	Y	4.5 [0.177]	5.5 [0.217]	7.5 [0.295]	9.5 [0.374]	1.5 [0.059]	2.5 [0.098]	4.5 [0.177]	6.5 [0.256]
	Z	8 [0.315]	9 [0.354]	11 [0.433]	13 [0.512]	4 [0.157]	5 [0.197]	7 [0.276]	9 [0.354]

CAUTION: Avoid using the horizontal lead wire sensor switch inserting from the rod side of the non-rotating double acting type.

Failure to do so may cause interference with the plate and results in damaging the lead wire. Be sure to use the vertical lead wire sensor switch.

Limited Warranty

KOGANEI CORP. warrants its products to be free from defects in material and workmanship subject to the following provisions.

Warranty Period The warranty period is 180 days from the date of delivery.

Koganei Responsibility If a defect in material or workmanship is found during the warranty period, KOGANEI CORP. will replace any part proved defective under normal use free of charge and will provide the service necessary to replace such a part.

Limitations

- This warranty is in lieu of all other warranties, expressed or implied, and is limited to the original cost of the product and shall not include any transportation fee, the cost of installation or any liability for direct, indirect or consequential damage or delay resulting from the defects.

- KOGANEI CORP. shall in no way be liable or responsible for injuries or damage to persons or property arising out of the use or operation of the manufacturer's product.

- This warranty shall be void if the engineered safety devices are removed, made inoperative or not periodically checked for proper functioning.

- Any operation beyond the rated capacity, any improper use or application, or any improper installation of the product, or any substitution upon it with parts not furnished or approved by KOGANEI CORP., shall void this warranty.

- This warranty covers only such items supplied by KOGANEI CORP. The products of other manufacturers are covered only by such warranties made by those original manufacturers, even though such items may have been included as the components.

The specifications are subject to change without notice.

URL <http://www.koganei.co.jp>

E-mail: overseas@koganei.co.jp



KOGANEI CORPORATION

OVERSEAS GROUP

3-11-28, Midori-cho, Koganei City, Tokyo 184-8533, Japan
Tel: 042-383-7271 Fax: 042-383-7276

KOGANEI INTERNATIONAL AMERICA, INC.

39300 Civic Center Dr., Suite 280, Fremont, CA 94538, U.S.A.
Tel: 510-744-1626 Fax: 510-744-1676

SHANGHAI KOGANEI INTERNATIONAL TRADING CORPORATION

Room 2606-2607, Tongda Venture Building No.1, Lane 600, Tianshan Road, Shanghai, 200051, China
Tel: 021-6145-7313 Fax: 021-6145-7323

KOGANEI KOREA CO., LTD.

KT&G Cosmo Bldg., 3F, 40-13, Maesanno 2-ga, Paldal-gu, Suwon-si, Gyeonggi-do, 442-847, Korea
Tel: 82-31-246-0414 Fax: 82-31-246-0415

KOGANEI-PORNCHAI CO., LTD.

89/174 Moo 3, Vibhavadee Rangsit Road, Talad Bangkhen, Laksi, Bangkok, 10210, Thailand
Tel: 02-551-4025 Fax: 02-551-4015

KOGANEI ASIA PTE. LTD.

7500A Beach Road #06-320, The Plaza, 199591, Singapore
Tel: 65-6293-4512 Fax: 65-6293-4513