

The new square cylinder with guides is the result of our relentless pursuit of cost performance and easy operation.

AXIS Cylinders

Koganei presents the new wave in air actuators, approached from the aspects of both function and design.

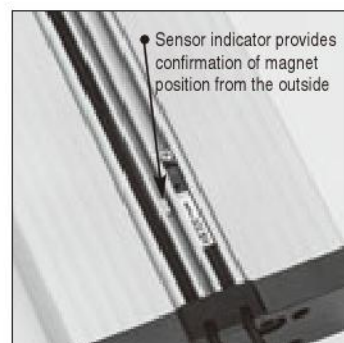
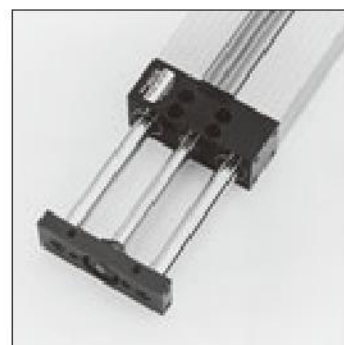
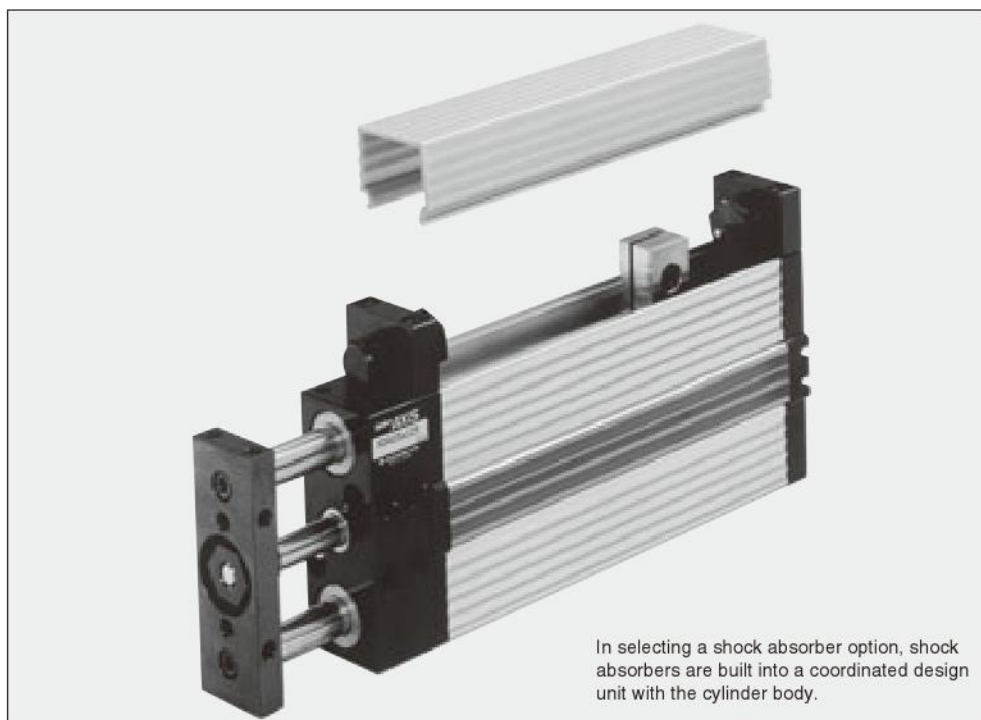

■ The non-rotating accuracy is $\pm 0.3^\circ$ or less for the standard (bushing) type, $\pm 0.1^\circ$ or less for the bearing type, and $\pm 0.05^\circ$ or less for the long bearing type. Three grades are available according to the guide configuration. By selecting non-rotating accuracy in accordance with 5 bore sizes in the range of $\phi 16$ [0.630in.]~ $\phi 40$ [1.575in.], and according to the application, it is possible to build pneumatic operating systems with extremely good cost performance.

■ The guides built into each side of the cylinder are compact and lightweight. Moreover, they have adequate rigidity. The highly clean-line body design with few protrusions is responsive to a variety of mounting types. Piping and wiring is also concentrated in a plane that eases mounting, adjustment, and maintenance.

■ A sensor indicator for confirmation of the operation point from outside and a magnet for the sensor switch are standard equipment. The compact sensor switch is mountable without any protrusions, and adjustment is also simple.

■ A compact shock absorber unit designed to fit the body comes with a newly-designed, built-in compact shock absorber. In the standard (single rod) cylinder, as well, 1 unit can be mounted on each end of the stroke.

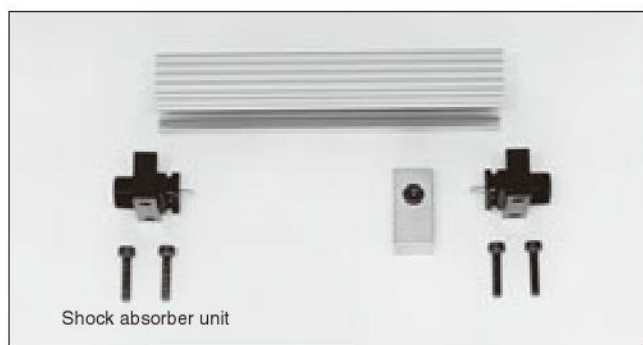

What is AXIS?

The **A** in AXIS stands for Access and Aggregation.

The **X** stands for Infinity.





The **I** stands for Intelligence.

The **S** stands for System and Sureness.

Moreover, AXIS has arrived with a mission, as its name implies, to create a new "axis," or standard, for air actuators.

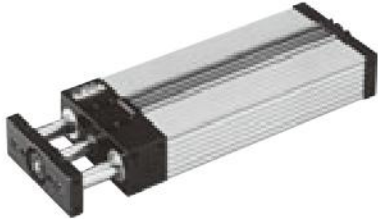
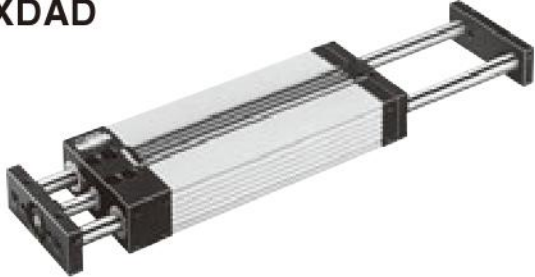

Basic Types and Configurations

● Main body

	Single rod	Double rod
Guide configuration	Bushing type (Standard) XDA 	Bushing type XDAD 
	Bearing type XDAA 	Bearing type XDAAD 
	Long bearing type XDAQ 	Long bearing type XDADQ 
Bore size	ϕ 16, 20, 25, 32, and 40 for each type	

AXIS CYLINDERS

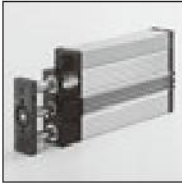
● Option

With piping adapter 	With shock absorber 	<table border="1"> <thead> <tr> <th>Bore size mm [in.]</th> <th>Maximum absorption N·m [ft·lbf]</th> </tr> </thead> <tbody> <tr> <td>16 [0.630]</td> <td>1.5 [1.11]</td> </tr> <tr> <td>20 [0.787]</td> <td>2.0 [1.48]</td> </tr> <tr> <td>25 [0.984]</td> <td>3.0 [2.21]</td> </tr> <tr> <td>32 [1.260]</td> <td>7.0 [5.16]</td> </tr> <tr> <td>40 [1.575]</td> <td>12.0 [8.85]</td> </tr> </tbody> </table>	Bore size mm [in.]	Maximum absorption N·m [ft·lbf]	16 [0.630]	1.5 [1.11]	20 [0.787]	2.0 [1.48]	25 [0.984]	3.0 [2.21]	32 [1.260]	7.0 [5.16]	40 [1.575]	12.0 [8.85]	
Bore size mm [in.]	Maximum absorption N·m [ft·lbf]														
16 [0.630]	1.5 [1.11]														
20 [0.787]	2.0 [1.48]														
25 [0.984]	3.0 [2.21]														
32 [1.260]	7.0 [5.16]														
40 [1.575]	12.0 [8.85]														
With head side mounting bracket 	With sensor switch 	<table border="1"> <thead> <tr> <th>Type</th> <th>Indicator lamp</th> <th>Model</th> <th>Lead wire length</th> </tr> </thead> <tbody> <tr> <td rowspan="2">Solid state type</td> <td>With indicator lamp</td> <td>ZC630□ ZC653□</td> <td rowspan="4">A : 1000mm [39in.] B : 3000mm [118in.]</td> </tr> <tr> <td rowspan="2">Reed switch type</td> <td>Without indicator lamp</td> <td>ZC601□</td> </tr> <tr> <td>With indicator lamp</td> <td>ZC605□</td> </tr> </tbody> </table>	Type	Indicator lamp	Model	Lead wire length	Solid state type	With indicator lamp	ZC630 □ ZC653 □	A : 1000mm [39in.] B : 3000mm [118in.]	Reed switch type	Without indicator lamp	ZC601 □	With indicator lamp	ZC605 □
Type	Indicator lamp	Model	Lead wire length												
Solid state type	With indicator lamp	ZC630 □ ZC653 □	A : 1000mm [39in.] B : 3000mm [118in.]												
	Reed switch type	Without indicator lamp		ZC601 □											
With indicator lamp		ZC605 □													

Instruction of Mounting

The AXIS cylinder is capable of various mounting configurations. See the examples below.

How to mount the body	<p>(1) Side mounting ①</p>	<p>(2) Side mounting ② (It is possible to mount on the right or the left.)</p>
	<p>(3) Head side direct mounting</p>	<p>(4) With head side side mounting bracket</p>
How to mount on the plate	<p>(1)</p>	<p>(2)</p>
	<p>(3)</p> <p>(It is possible to mount on the right or the left.)</p>	<p>(4)</p> <p>(It is possible to mount on the top or the bottom.)</p>

AXIS Cylinder Application Example

<p>(1) Pusher, lifter, and stopper</p>	<p>(2) Simple robot</p>	<p>(3) Pressing</p>
<p>(4) Clamping</p>	<p>(5) Table</p> <p>① Plate fixed type</p> <p>② Body fixed type</p>	<p>(6) Escape</p>

AXIS CYLINDERS

Specification List

Symbol

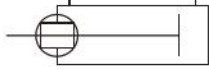

Specifications

		Bore size mm [in.]				
Item		16 [0.630]	20 [0.787]	25 [0.984]	32 [1.260]	40 [1.575]
Operation type		Double acting type				
Media		Air				
Mounting type		Side mounting (3 directions) Head side direct mounting Head side side mounting ^{Note 1}				
Operating pressure range		MPa [psi.] 0.1~0.7 [15~102]				
Proof pressure		MPa [psi.] 1.03 [149]				
Operating temperature range		°C [°F] 0~60 [32~140]				
Operating speed range		mm/s [in./sec.] 100~500 [3.9~19.7]				
Cushion	Standard	Rubber bumper				
	Option	Shock absorber				
Lubrication		Not required				
Non-rotating accuracy	Standard (bushing) specification	±0.3° or less				
	Bearing specification	±0.1° or less				
	Long bearing specification	±0.05° or less				
Stroke adjusting range (per one side to the specification stroke) ^{Note 2}		mm [in.] -5~0 [-0.197~0]	-12~0 [-0.472~0]	-15~0 [-0.591~0]	-20~0 [-0.787~0]	-23~0 [-0.906~0]
Port size		M5×0.8			Rc1/8	

Notes: 1. Mounting bracket is optional.

2. Only for cases where a shock absorber has been mounted.

Bore Size and Stroke

Bore size	Standard strokes	Maximum available stroke	
		XDA, XDAА, XDAQ, XDAD	XDAAD, XDADQ
		mm	
16	25, 50, 75, 100, 125	500	200
20	25, 50, 75, 100, 125, 150	500	500
25	25, 50, 75, 100, 125, 150, 175	500	500
32	25, 50, 75, 100, 125, 150, 175, 200, 225	500	500
40	25, 50, 75, 100, 125, 150, 175, 200, 225, 250, 275, 300	500	500

Notes: 1. For the delivery, consult us.

2. The ϕ 16 [0.630in.] double rod bearing type and long bearing type are only available with a maximum stroke of 200mm.

Remark: For non-standard strokes, consult us.

Mass

Guide configuration Bore size mm [in.]	Single rod				Double rod				Additional mass for options			
	Zero stroke mass			Additional mass for each 1mm [0.394in.] stroke	Zero stroke mass			Additional mass for each 1mm [0.394in.] stroke	Head side side mounting bracket -2	Piping adapter -L	Shock absorber unit -SS□	Sensor switches
	Standard (Bushing) XDA	Bearing XDAA	Long bearing XDAQ		Bushing XDAD	Bearing XDAAD	Long bearing XDADQ					
	kg [lb.]											
16 [0.630]	0.293 [0.646]	0.305 [0.673]	0.365 [0.805]	0.003 [0.007]	0.351 [0.774]	0.363 [0.800]	0.423 [0.933]	0.004 [0.009]	0.048 [0.106]	0.043 [0.095]	0.113 [0.249]	Lead wire A (1000mm) : 0.02 [0.04] Lead wire B (3000mm) : 0.05 [0.11]
20 [0.787]	0.506 [1.116]	0.526 [1.160]	0.639 [1.409]	0.004 [0.009]	0.593 [1.308]	0.613 [1.352]	0.726 [1.601]	0.005 [0.011]	0.064 [0.141]	0.058 [0.128]	0.188 [0.415]	
25 [0.984]	0.601 [1.325]	0.62 [1.367]	0.774 [1.707]	0.005 [0.011]	0.731 [1.612]	0.751 [1.656]	0.904 [1.993]	0.007 [0.015]	0.093 [0.205]	0.077 [0.170]	0.244 [0.538]	
32 [1.260]	0.997 [2.198]	1.043 [2.300]	1.294 [2.853]	0.008 [0.018]	1.261 [2.781]	1.307 [2.882]	1.559 [3.438]	0.011 [0.024]	0.161 [0.355]	0.161 [0.355]	0.442 [0.975]	
40 [1.575]	1.024 [2.258]	1.093 [2.410]	1.42 [3.131]	0.012 [0.026]	1.485 [3.274]	1.554 [3.427]	1.88 [4.145]	0.017 [0.037]	0.279 [0.615]	0.23 [0.507]	0.615 [1.356]	

Inner Construction

The diagrams show the case of a $\phi 16$ standard type (single rod bushing type) with shock absorbers.

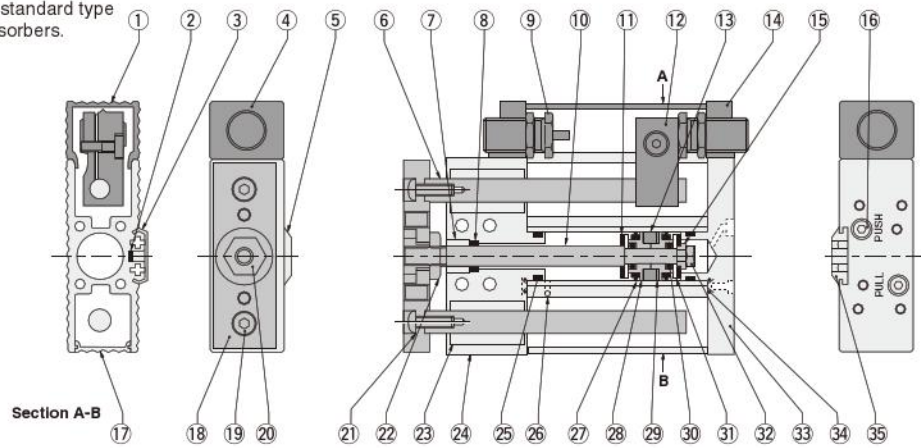

The diagrams show the case of a $\phi 16$ double rod bushing type with shock absorbers.

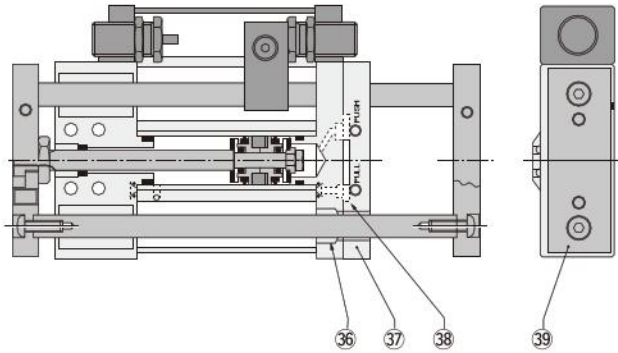

Major Parts and Materials

No.	Parts	Materials	No.	Parts	Materials
①	Shock absorber cover	Plastic	⑳	Washer	Steel (zinc plated)
②	Indicator	Mild steel	㉑	Joint nut B	Mild steel (zinc plated)
③	Sensor cover	Plastic	㉒	Bearing	Aluminum alloy (hard anodized), [with bearing type (steel, plastic)]
④	Holder	Aluminum alloy (anodized)	㉓	Rod cover	Aluminum alloy (anodized)
⑤	Cover	Synthetic rubber (NBR)	㉔	O-ring (for tube gasket)	Synthetic rubber (NBR)
⑥	Guide rod	Steel (hard chrome plated, the bearing type is not plated.)	㉕	Steel ball	Steel
⑦	Rod bushing	Sintered alloy	㉖	Piston seal	Synthetic rubber (NBR)
⑧	Rod seal	Synthetic rubber (NBR)	㉗	Piston	Plastic
⑨	Shock absorber	—	㉘	Spacer	Plastic (only for $\phi 16$ [0.630in.] and $\phi 20$ [0.787in.]
⑩	Piston rod	Steel (hard chrome plated)	㉙	O-ring (for piston gasket)	Synthetic rubber (NBR)
⑪	Bumper	Synthetic rubber (NBR)	㉚	Retainer washer	Mild steel (nickel plated)
⑫	Stopper	Steel (zinc plated)	㉛	Hexagon nut	Mild steel (zinc plated)
⑬	Magnet	$\phi 16$ and $\phi 20$ are rare earth magnet, and $\phi 25$ or larger are plastic magnet.	㉜	Head cover	Aluminum alloy (anodized)
⑭	Holder	Aluminum alloy (anodized)	㉝	O-ring (for by-pass gasket)	Synthetic rubber (NBR)
⑮	Washer	Mild steel (zinc plated)	㉞	Lead wire holder	Synthetic rubber (NBR)
⑯	Hexagon socket head bolt	Steel (zinc plated)	㉟	Bearing	Oil impregnated plastic
㉑	Side cover	Plastic	㊱	Piping adapter	Aluminum alloy (anodized)
㉒	Plate	Special aluminum alloy (anodized)	㊲	Gasket	Synthetic rubber (NBR)
㉓	Hexagon socket head bolt	Steel (nickel plated)	㊳	Plate B	Special aluminum alloy (anodized)
㉔	Joint nut A	Mild steel (zinc plated)			

Seals

Item	Rod seal		Piston seal	O-ring (For piston gasket)	O-ring (For by-pass gasket)	Gasket (Option)	O-ring (For tube gasket)
	Quantity		2	2	2	—	2
16	1		2	2	2	—	2
	NY-3-6		PPY-16	P-5	1.5×3.5	L089031	SO-015-16
20	1		2	2	2	—	2
	NY-12×8×3.5		PPY-20	P-6	1.5×3.5	L089032	1/16×11/16×13/16
25	1		2	2	2	—	2
	NY-14×10×3.5		PPY-25	P-7	1.5×4.5	L089033	1/16×7/8×1
32	1		2	2	2	—	2
	NY-17×12×4		PPY-32	P-10	1.5×5.5	L089034	1/16×1½×1¼
40	1		2	2	2	—	2
	NY-22×16×5		PPY-40	P-12	1.5×7.5	L089035	S36

List of Bearing in Use

Bore size mm	Item	Bearing	Long bearing
16		LB8NYDD	SM8GWUU
20		LB10NYDD	SM10GWUU
25		LB12NYDD	SM12GWUU
32		LB16NYDD	SM16GWUU
40		LB20NYDD	SM20GWUU

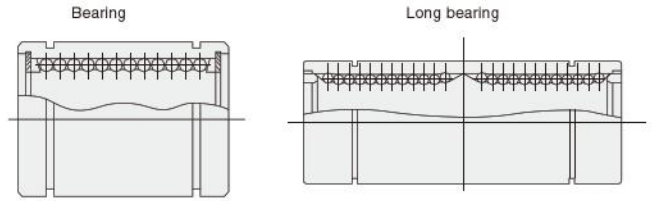

Allowable Lateral Load and Stroke

- The lateral load on the rod bearing should be at or below the graph values shown below. (Values are the same for both the single rod and the double rod.)

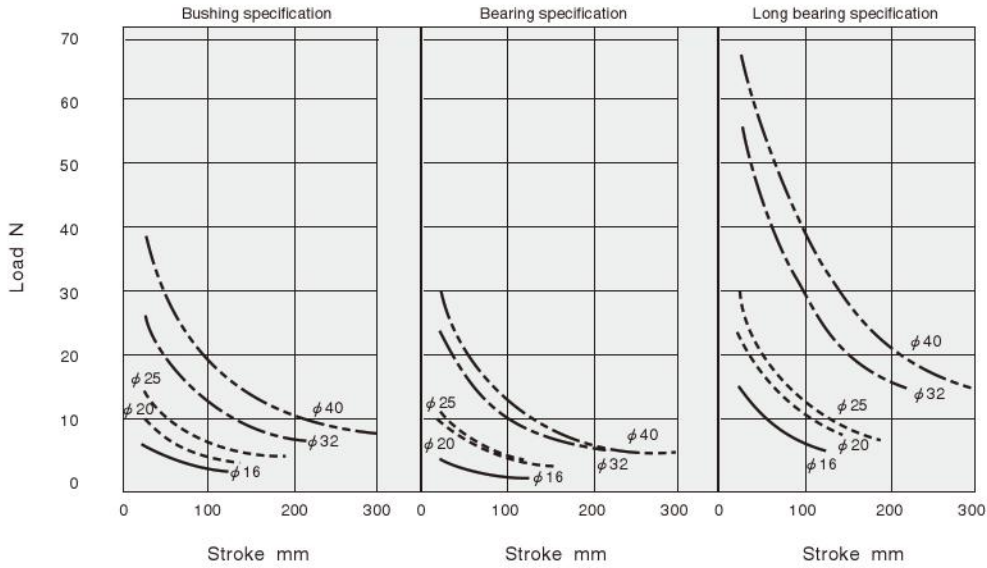
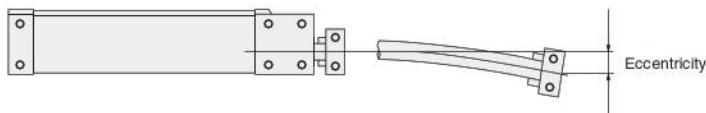
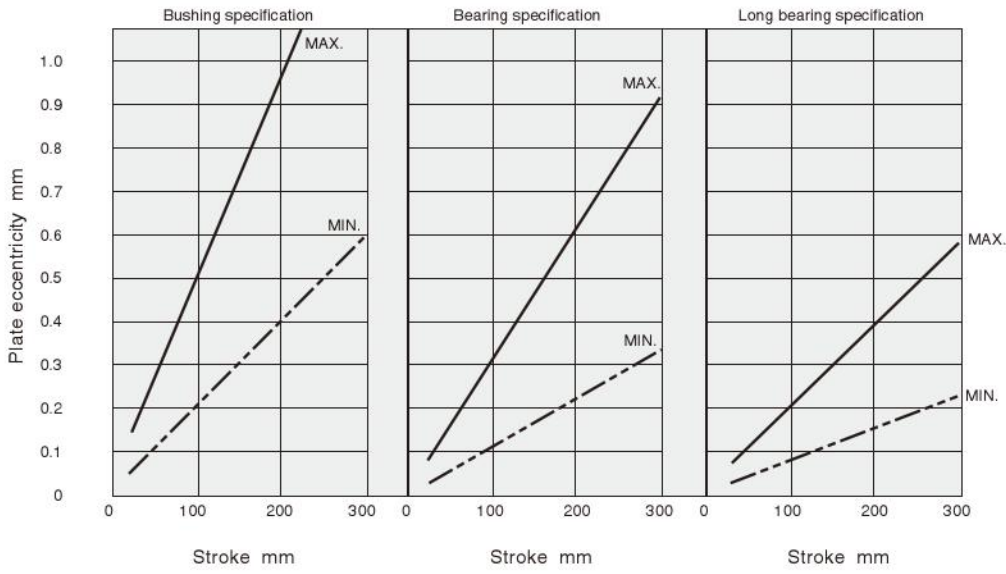

Plate Eccentricity and Stroke

- The eccentricity of the plate without applying load is shown in the graphs below. (The graphs below are for a single rod. For the double rod, cut the graph values below in half.)



Due to the axis cylinder's design clearance and the weight of the rod, etc., the rod end plate deflects as shown in the diagram above.

Allowable Kinetic Energy

Axis Cylinders are equipped with a cushioning mechanism. This mechanism is intended to reduce as much as possible the impact of pistons with high kinetic energy when they stop at the end of the stroke. There are 2 types of cushions, as shown below.

● Rubber bumpers (standard equipment)

Rubber bumpers installed on both sides of the piston soften the impact at the end of the stroke, and absorb the impact noise during stopping, in response to high-frequency and high-speed operations.

Note that a certain degree of rebound will occur at the end of the stroke on the cylinder with the rubber bumpers.

The load kinetic energy can be obtained through the formula shown below.

$$Ex = \frac{m}{2} v^2$$

$$E'x = \frac{W}{2g} v'^2$$

Ex : Kinetic energy (J)
 m : Load mass (kg)
 v : Piston speed (m/s)

E'x : Kinetic energy [ft·lbf]
 W : Load [lbf.]
 v' : Piston speed [ft./sec.]
 g : Acceleration of gravity 32.2 [ft./sec.²]

Bore size mm [in.]	Allowable kinetic energy J [ft·lbf]	
	For rubber bumpers	
16 [0.630]	0.07 [0.05]	
20 [0.787]	0.27 [0.20]	
25 [0.984]	0.4 [0.30]	
32 [1.260]	0.65 [0.48]	
40 [1.575]	1.2 [0.89]	

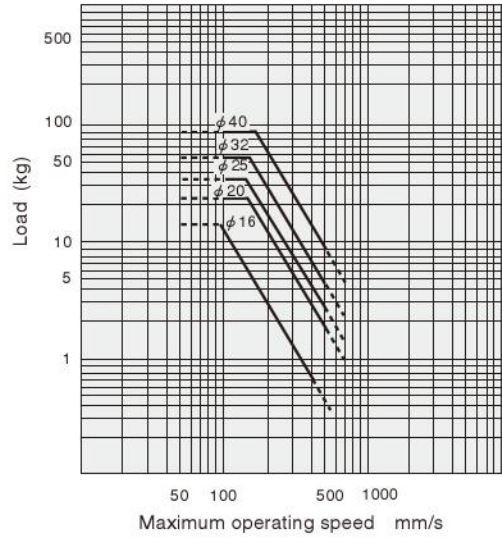

● With shock absorber (Optional)

Use shock absorbers for large loads and high-speed operations where rubber bumpers provide insufficient absorption. Hydraulic flow resistance is used to absorb the shocks when the piston stops at the end of the stroke.

Since the absorbing stroke is included in the cylinder stroke, be careful when operations are 25mm strokes or shorter.

For the impact energy calculation formula, see the "Selection Guidelines" on p.528 in the General Catalog of Air Treatment, Auxiliary, Vacuum.

Operating speed range

- Rubber bumpers 100~500mm/s [0.33~1.64ft./sec.]
- With shock absorbers 100~500mm/s [0.33~1.64ft./sec.]

Bore size mm [in.]	Shock absorber model	J [ft·lbf]	
		Maximum absorption	
16 [0.630]	KSHAX 6×5	1.5 [1.1]	
20 [0.787]	KSHAX 7×5	2.0 [1.5]	
25 [0.984]	KSHAX 8×6	2.9 [2.1]	
32 [1.260]	KSHAX 10×8	6.9 [5.1]	
40 [1.575]	KSHAX 12×10	11.8 [8.7]	

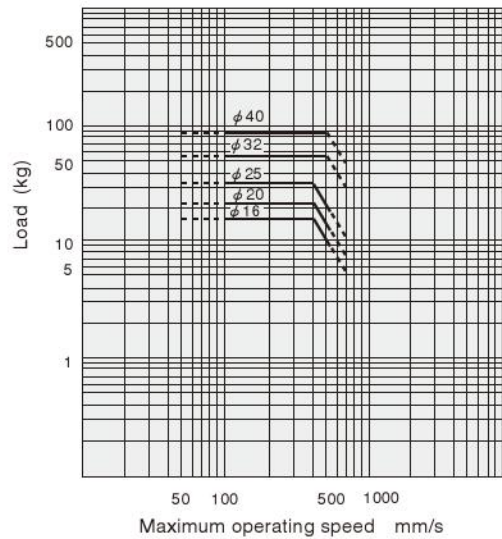

1kg = 2.205lb.
1mm/s = 0.0394in./sec.

Cylinder Thrust

N [lbf.]

Bore size mm [in.]	Rod diameter mm [in.]	Operation direction	Pressure area mm ² [in. ²]	Operating pressure MPa [psi.]						
				0.1 [15]	0.2 [29]	0.3 [44]	0.4 [58]	0.5 [73]	0.6 [87]	0.7 [102]
16 [0.630]	6 [0.236]	Push side	201 [0.312]	20.1 [4.52]	40.2 [9.04]	60.3 [13.56]	80.4 [18.07]	100.5 [22.59]	120.6 [27.11]	140.7 [31.63]
		Pull side	172 [0.267]	17.2 [3.87]	34.4 [7.73]	51.6 [11.60]	68.8 [15.47]	86 [19.33]	103.2 [23.20]	120.4 [27.07]
20 [0.787]	8 [0.315]	Push side	314 [0.487]	31.4 [7.06]	62.8 [14.12]	94.2 [21.18]	125.6 [28.23]	157 [35.29]	188.4 [42.35]	219.8 [49.41]
		Pull side	264 [0.409]	26.4 [5.93]	52.8 [11.87]	79.2 [17.80]	105.6 [23.74]	132 [29.67]	158.4 [35.61]	184.8 [41.54]
25 [0.984]	10 [0.394]	Push side	409 [0.634]	40.0 [8.99]	81.8 [18.39]	122.7 [27.58]	163.6 [36.78]	204.5 [45.97]	245.4 [55.17]	286.3 [64.36]
		Pull side	412 [0.639]	41.2 [9.26]	82.4 [18.52]	123.6 [27.79]	164.8 [37.05]	206 [46.31]	247.2 [55.57]	288.4 [64.83]
32 [1.260]	12 [0.472]	Push side	804 [1.246]	80.4 [18.07]	160.8 [36.15]	241.2 [54.22]	321.6 [72.30]	402 [90.37]	482.4 [108.45]	562.8 [126.52]
		Pull side	690 [1.070]	69 [15.5]	138 [31.0]	207 [46.5]	276 [62.0]	345 [77.6]	414 [93.1]	483 [108.6]
40 [1.575]	16 [0.630]	Push side	1256 [1.947]	125.6 [28.23]	251.2 [56.47]	376.8 [84.71]	502.4 [112.94]	628 [141.17]	753.6 [169.41]	879.2 [197.64]
		Pull side	1055 [1.635]	105.5 [23.72]	211 [47.43]	316.5 [71.15]	422 [94.87]	527.5 [118.58]	633 [142.30]	738.5 [166.01]

Air Flow Rate and Air Consumption

While the air cylinder's air flow rate and air consumption can be found through the following calculations, the quick reference chart on the next page provides the answers more conveniently.

$$\begin{aligned}
 \text{Air flow rate } Q_1 &= \left[\frac{\pi D^2}{4} \times L \times \frac{60}{t} \times \frac{P+0.101}{0.101} \times 10^{-6} \right] + \left[\frac{\pi a^2}{4} \times (L+b) \times \frac{60}{t} \times \frac{P}{0.101} \times 10^{-6} \right] \\
 \text{Air consumption } Q_2 &= \left[\frac{\pi [D^2 + (D^2 - d^2)]}{4} \times L \times n \times \frac{P+0.101}{0.101} \times 10^{-6} \right] + \left[\frac{\pi a^2}{4} \times (L+b) \times n \times \frac{P}{0.101} \times 10^{-6} \right]
 \end{aligned}$$

← Cylinder tube section →
← By-pass section →

mm [in.]			
Bore size: D	Piston rod dia.: d	By-pass diameter: a	Cylinder body fixed dimension: b
16 [0.630]	6 [0.236]	3 [0.118]	36 [1.417]
20 [0.787]	8 [0.315]	3 [0.118]	40 [1.575]
25 [0.984]	10 [0.394]	3.9 [0.154]	40 [1.575]
32 [1.260]	12 [0.472]	4.7 [0.185]	40 [1.575]
40 [1.575]	16 [0.630]	6.4 [0.252]	44 [1.732]

- Q₁ : Required air flow rate for cylinder ℓ/min (ANR)
- Q₂ : Air consumption of cylinder ℓ/min (ANR)
- L : Cylinder stroke mm
- t : Time required for cylinder to travel 1 stroke s
- n : Number of cylinder reciprocations per minute times/min
- P : Pressure Mpa

$$\begin{aligned}
 \text{Air flow rate } Q_1' &= \left[\frac{\pi D'^2}{4} \times L' \times \frac{60}{t} \times \frac{P'+14.7}{14.7} \times \frac{1}{1728} \right] + \left[\frac{\pi a^2}{4} \times (L'+b) \times \frac{60}{t} \times \frac{P'}{14.7} \times \frac{1}{1728} \right] \\
 \text{Air consumption } Q_2' &= \left[\frac{\pi [D'^2 + (D'^2 - d'^2)]}{4} \times L' \times n \times \frac{P'+14.7}{14.7} \times \frac{1}{1728} \right] + \left[\frac{\pi a^2}{4} \times (L'+b) \times n \times \frac{P'}{14.7} \times \frac{1}{1728} \right]
 \end{aligned}$$

← Cylinder tube section →
← By-pass section →

- Q₁' : Required air flow rate for cylinder (ft³/min. (ANR))*
- Q₂' : Air consumption of cylinder (ft³/min. (ANR))*
- L' : Cylinder stroke [in.]
- t : Time required for cylinder to travel 1 stroke [sec.]
- n : Number of cylinder reciprocations per minute (times/min.)
- P' : Pressure [psi.]
- D' : Bore size [in.]
- a : By-pass diameter [in.]
- b : Cylinder body fixed dimension [in.]
- d : Piston rod diameter [in.]

* Refer to p.54 for an explanation of ANR.

Air Flow Rate and Air Consumption

Air consumption for zero stroke and each 1mm [0.0394in.] stroke cm³ [in.³]/Reciprocation (ANR)

Conditions concerning stroke	Air pressure MPa [psi.]							
	Bore size mm [in.]	0.1 [15]	0.2 [29]	0.3 [44]	0.4 [58]	0.5 [73]	0.6 [87]	0.7 [102]
Air consumption at zero stroke (constant value)	16 [0.630]	0.25 [0.0153]	0.50 [0.0305]	0.76 [0.0464]	1.01 [0.0616]	1.26 [0.0769]	1.51 [0.0921]	1.76 [0.1074]
	20 [0.787]	0.28 [0.0171]	0.56 [0.0342]	0.84 [0.0513]	1.12 [0.0683]	1.40 [0.0854]	1.68 [0.1025]	1.96 [0.1196]
	25 [0.984]	0.47 [0.0287]	0.95 [0.0580]	1.42 [0.0867]	1.89 [0.1153]	2.36 [0.1440]	2.84 [0.1733]	3.31 [0.2020]
	32 [1.260]	0.69 [0.0421]	1.37 [0.0836]	2.06 [0.1257]	2.75 [0.1678]	3.43 [0.2093]	4.12 [0.2514]	4.81 [0.2935]
	40 [1.575]	1.40 [0.0854]	2.80 [0.1709]	4.20 [0.2563]	5.60 [0.3417]	7.00 [0.4272]	8.40 [0.5126]	9.81 [0.5986]
Additional air consumption for each 1mm [0.0394in.] stroke (additional value)	16 [0.630]	0.75 [0.0458]	1.13 [0.0690]	1.50 [0.0915]	1.88 [0.1147]	2.26 [0.1379]	2.64 [0.1611]	3.01 [0.1837]
	20 [0.787]	1.16 [0.0708]	1.74 [0.1062]	2.31 [0.1410]	2.89 [0.1764]	3.47 [0.2118]	4.05 [0.2471]	4.63 [0.2825]
	25 [0.984]	1.81 [0.1105]	2.71 [0.1654]	3.62 [0.2209]	4.53 [0.2764]	5.43 [0.3314]	6.34 [0.3869]	7.24 [0.4418]
	32 [1.260]	2.99 [0.1825]	4.49 [0.2740]	5.99 [0.3655]	7.48 [0.4565]	8.98 [0.5480]	10.48 [0.6395]	11.97 [0.7305]
	40 [1.575]	4.63 [0.2825]	6.95 [0.4241]	9.27 [0.5657]	11.59 [0.7073]	13.91 [0.8488]	16.23 [0.9904]	18.55 [1.132]

The figures in the table are for calculating the air flow rate and air consumption during 1 reciprocation of an Axis cylinder between a zero and 1mm [0.0394in.] stroke.

The air flow rate and air consumption actually required is found by the following calculations.

● **Finding the air flow rate (for selecting F.R.L., valves, etc.)**

Example: When operating an AXIS cylinder with bore size of 40mm [1.575in.] at speed of 300mm/s [11.8in./sec.], under air pressure of 0.5MPa {5.1kgf/cm²} [73psi.]

$$\frac{\{(13.91 \times 300) + 7.00\}}{2} \times 10^{-3} = 2.09 \text{ l/s [0.0738ft}^3\text{/sec.]} \text{ (ANR)}$$

Speed
From the table (air consumption at zero stroke)
From the table (additional air consumption for each 1mm stroke)

(At this time, the flow rate per minute is $\{(13.91 \times 300) + 7.00\} \times \frac{1}{2} \times 60 \times 10^{-3} = 125.4 \text{ l/min [4.427ft}^3\text{/min.]} \text{ (ANR)}$)

● **Finding the air consumption**















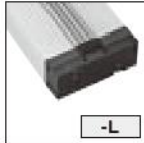
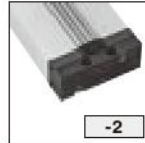

Example 1. When operating an AXIS cylinder with bore size of 40mm [1.575in.] and stroke of 100mm [3.94in.], under air pressure of 0.5MPa {5.1kgf/cm²} [73psi.], for 1 reciprocation

$$\{(13.91 \times 100) + 7.00\} \times 10^{-3} = 1.398 \text{ l/Reciprocation [0.04935ft}^3\text{/Reciprocation]} \text{ (ANR)}$$

Example 2. When operating an AXIS cylinder with bore size of 40mm [1.575in.] and stroke of 100mm [3.94in.], under air pressure of 0.5MPa {5.1kgf/cm²} [73psi.], for 10 reciprocations per minute

$$\{(13.91 \times 100) + 7.00\} \times 10 \times 10^{-3} = 13.98 \text{ l/min [0.4935ft}^3\text{/min.]} \text{ (ANR)}$$

Order Codes

Guide construction		Piping adapter	Mounting bracket	Shock absorber	Sensor switch (Type, Lead wire length, Quantity) ^{Note4}	
Single rod bushing type  Blank	Double rod bushing type  D	No piping adapter  Blank	No mounting bracket  Blank	No shock absorber  Blank	No sensor switch  Blank	
Single rod bearing type  A	Double rod bearing type  AD	With piping adapter ^{Note1}  -L	With head side side mounting bracket ^{Note2}  -2	With shock absorbers (The left side) ^{Note3}  -SSL	With ZC630  -ZC630	With ZC601  -ZC601
Single rod long bearing type  Q	Double rod long bearing type  DQ			With shock absorbers (The right side) ^{Note3}  -SSR	With ZC653  -ZC653	With ZC605  -ZC605

- Lead wire length
A : 1000mm [39in.]
B : 3000mm [118in.]
- Number of sensor switches
1 : With 1 sensor switch
2 : With 2 sensor switches

- For specifications, see p.863.
- Solid state type
- With indicator lamp
- DC10~28V
- For the order codes of sensor switches only, see p.861.
- Reed switch type
- Without indicator lamp
- DC5~28V
- AC85~115V
- For the order codes of shock absorbers only, see p.863.
- Solid state type
- With indicator lamp
- DC4.5~28V
- Reed switch type
- With indicator lamp
- DC10~28V

Basic type	Bore size × Stroke							
XDA	A Q	×	-L	-2	-SSL -SSR	-ZC630 -ZC653 -ZC601 -ZC605	A B	1 2 ⋮
	D AD DQ	×						

- For bore size and stroke, see p.848.
- The order code of the piping adapter only is L-XDA□
□ Bore size
- The order code of the mounting bracket only is 2-XDA□
□ Bore size
- For the order codes of sensor switches only, see p.861.
- For the order codes of shock absorbers only, see p.863.

Notes: 1. Included at shipping in the single rod type. Assembled (standard equipment) at shipping in the double rod type.
 2. Included at shipping in the single rod type. Assembled at shipping in the double rod type.
 3. Assembled at shipping.
 4. The sensor cover cannot be attached when 3 or more sensor switches have been mounted. It cannot be mounted so as to protrude from the sensor switch mounting groove.

Custom-made (Made to Order)

Steel plate specification



Insert the order code ahead of the piping adapter.

AXIS CYLINDERS

Dimensions of Single Rod Bushing Type, and Single Rod Bearing Type (mm)

XDA Bore size × Stroke
 XDAA Bore size × Stroke

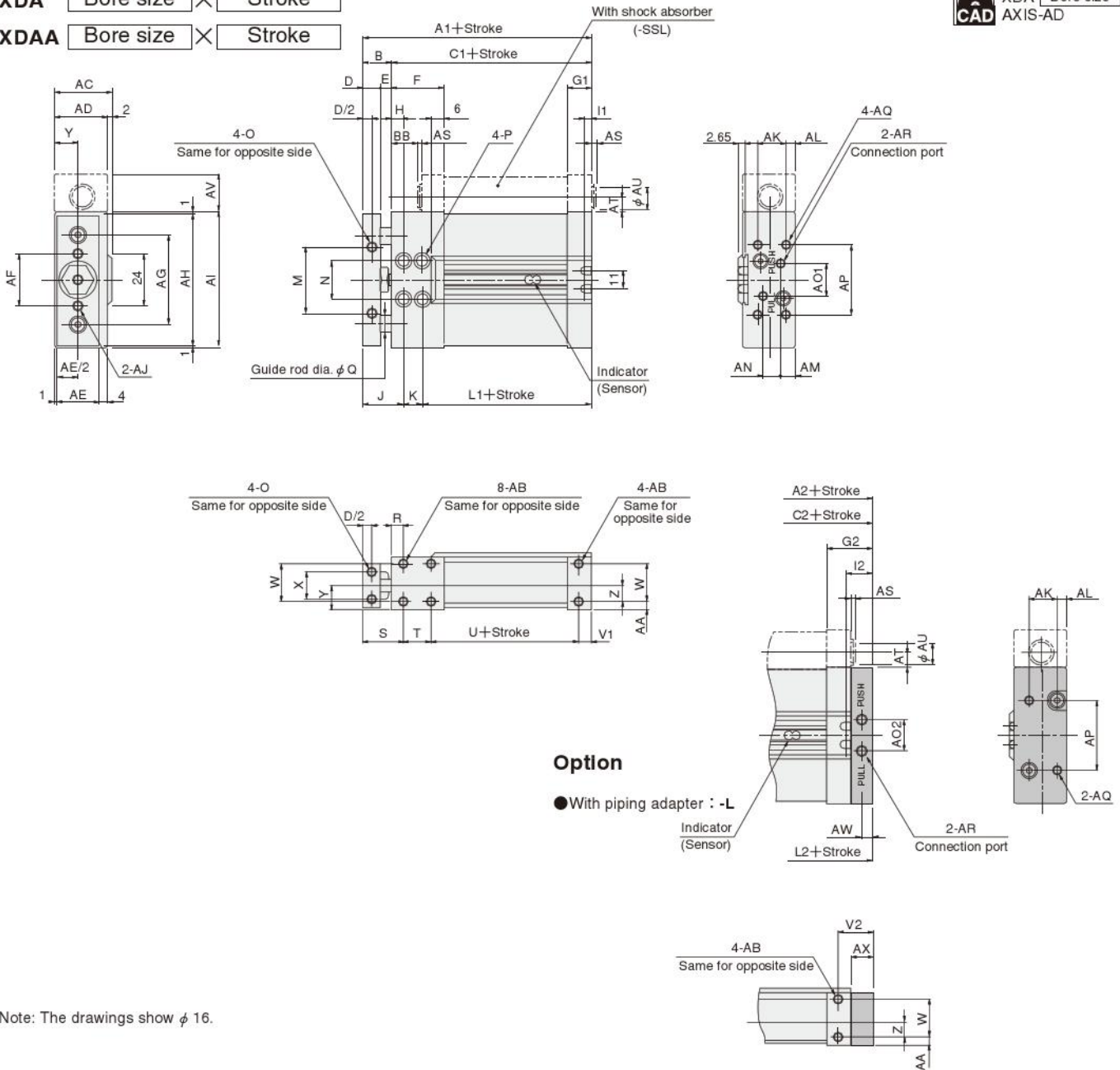

Option

- With piping adapter : -L

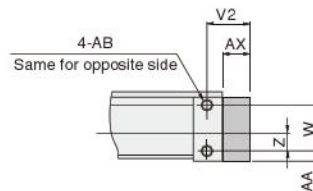

Note: The drawings show ϕ 16.

Bore mm [In.]	Code	A1	A2	B	C1	C2	D	E	F	G1	G2	H	I1	I2	J	K	L1	L2	M	N	O (Mounting thread)
16 [0.630]		86	96	14	72	82	8	6	25	11	21	5.5	2.75	12.75	19.5	9	57.5	67.5	32	19	M4×0.7 Depth5
20 [0.787]		96	106	15	81	91	8	7	30	11	21	6	2.75	12.75	21	13	62	72	36	21	M4×0.7 Depth6
25 [0.984]		99	109	17	82	92	10	7	31	11	21	6.5	2.75	12.75	23.5	11.5	64	74	42	25	M5×0.8 Depth7
32 [1.260]		114	128	20	94	108	12	8	38	16	30	7.5	2.75	16.75	27.5	15	71.5	85.5	50	29	M6×1 Depth8
40 [1.575]		128	142	25	103	117	15	10	43	16	30	9	2.75	16.75	34	15.5	78.5	92.5	60	37	M8×1.25Depth11

Bore mm [In.]	Code	P (Mounting hole)	Q	R	S	T	U	V1	V2	W	X	Y	Z	AA	AB (Mounting thread)	AC	AD	AE	AF	AG	AH
16 [0.630]		ϕ 4.5 Counterbore ϕ 8 Depth12	8	5.5	19.5	14	47	5.5	15.5	17	12	11	7	4	M4×0.7 Depth5	27	25	20	25	43	62
20 [0.787]		ϕ 4.5 Counterbore ϕ 8 Depth13	10	5.5	20.5	19	51	5.5	15.5	20	16	13	8.5	4.5	M4×0.7 Depth6	31	29	24	28	49	72
25 [0.984]		ϕ 5.5 Counterbore ϕ 9.5 Depth14	12	5.5	22.5	20	51	5.5	15.5	23	20	15.5	10	5.5	M5×0.8 Depth6	36	34	29	34	57	82
32 [1.260]		ϕ 6.6 Counterbore ϕ 11 Depth16	16	8	28	22	56	8	22	28	24	19	12.5	6.5	M6×1 Depth7	43	41	36	40	69	102
40 [1.575]		ϕ 9 Counterbore ϕ 14 Depth19	20	8	33	27	60	8	22	33	29	23	15	8	M8×1.25 Depth8	51	49	44	48	84	122

Bore mm [In.]	Code	Ai	Aj (Mounting thread and mounting hole)	AK	AL	AM	AN	AO1	AO2	AP	AQ (Mounting thread)	AR (Connection port)	AS	AT	AU	AV	AW	AX	BB
16 [0.630]		64	M5×0.8 Inner dia. ϕ 4.3	14	4	6	10	17	16	34	M4×0.7 Depth5	M5×0.8	1	7.5	12	19	5	10	13
20 [0.787]		74	M5×0.8 Inner dia. ϕ 4.3	18	4	7	12	22	18	39	M4×0.7 Depth5	M5×0.8	8	8	14	21	5	10	11
25 [0.984]		84	M6×1 Inner dia. ϕ 5.3	21	5	7.5	16	26	20	45	M5×0.8 Depth6	M5×0.8	11	9	16	23	5	10	9
32 [1.260]		104	M8×1.25 Inner dia. ϕ 6.8	26	6	10	18	33	24	54	M6×1 Depth8	Rc 1/8	14	12	20	29	7	14	8
40 [1.575]		124	M10×1.5 Inner dia. ϕ 8.5	32	7	12	22	42	30	66	M8×1.25 Depth10	Rc 1/8	17	13	22	31	7	14	10

Dimensions of Single Rod Bushing and Bearing Types with Head Side Side Mounting Brackets (mm)

XDA Bore size × Stroke -2
 XDAA Bore size × Stroke -2

CAD XDA Bore size
 AXIS-BR1
 AXIS-BR2
 AXIS-AD

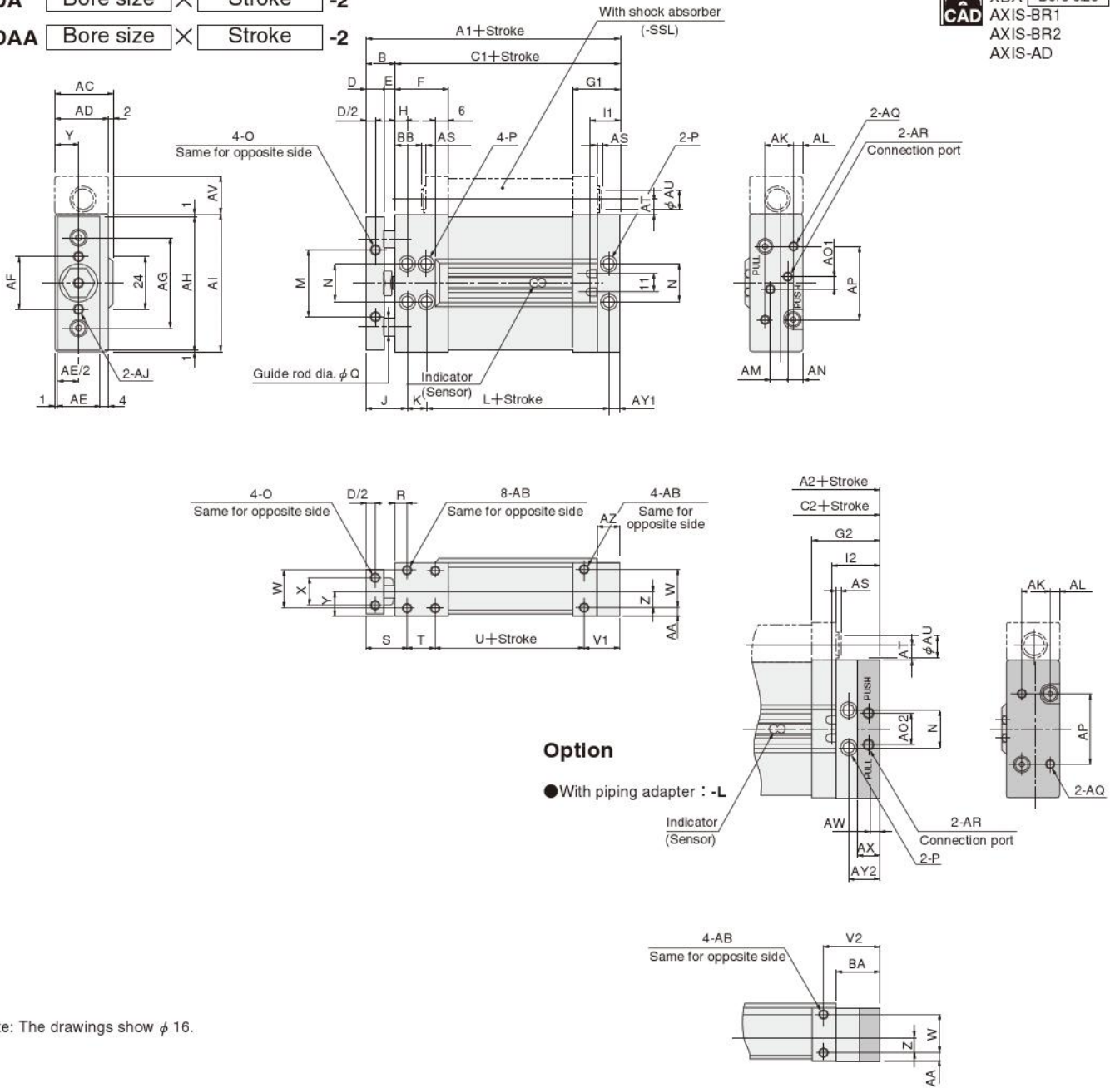

Note: The drawings show ϕ 16.

Bore mm [In.]	Code	A1	A2	B	C1	C2	D	E	F	G1	G2	H	I1	I2	J	K	L	M	N	O (Mounting thread)	P (Mounting hole)
16 [0.630]		97	107	14	83	93	8	6	25	22	32	5.5	13.75	23.75	19.5	9	63.5	32	19	M4×0.7 Depth5	ϕ 4.5 Counterbore ϕ 8 Depth12
20 [0.787]		107	117	15	92	102	8	7	30	22	32	6	13.75	23.75	21	13	68	36	21	M4×0.7 Depth6	ϕ 4.5 Counterbore ϕ 8 Depth13
25 [0.984]		111	121	17	94	104	10	7	31	23	33	6.5	14.75	24.75	23.5	11.5	70.5	42	25	M5×0.8 Depth7	ϕ 5.5 Counterbore ϕ 9.5 Depth14
32 [1.260]		128	142	20	108	122	12	8	38	30	44	7.5	16.75	30.75	27.5	15	79	50	29	M6×1 Depth8	ϕ 6.6 Counterbore ϕ 11 Depth16
40 [1.575]		145	159	25	120	134	15	10	43	33	47	9	19.75	33.75	34	15.5	87.5	60	37	M8×1.25 Depth11	ϕ 9 Counterbore ϕ 14 Depth19

Bore mm [In.]	Code	Q	R	S	T	U	V1	V2	W	X	Y	Z	AA	AB (Mounting thread)	AC	AD	AE	AF	AG	AH	AI	AJ (Mounting thread and mounting hole)
16 [0.630]		8	5.5	19.5	14	47	16.5	26.5	17	12	11	7	4	M4×0.7 Depth5	27	25	20	25	43	62	64	M5 X0.8 Inner dia. ϕ 4.3
20 [0.787]		10	5.5	20.5	19	51	16.5	26.5	20	16	13	8.5	4.5	M4×0.7 Depth5	31	29	24	28	49	72	74	M5 X0.8 Inner dia. ϕ 4.3
25 [0.984]		12	5.5	22.5	20	51	17.5	27.5	23	20	15.5	10	5.5	M5×0.8 Depth6	36	34	29	34	57	82	84	M6 X1 Inner dia. ϕ 5.3
32 [1.260]		16	8	28	22	56	22	36	28	24	19	12.5	6.5	M6×1 Depth7	43	41	36	40	69	102	104	M8 X1.25 Inner dia. ϕ 6.8
40 [1.575]		20	8	33	27	60	25	39	33	29	23	15	8	M8×1.25 Depth8	51	49	44	48	84	122	124	M10 X1.5 Inner dia. ϕ 8.5

Bore mm [In.]	Code	AK	AL	AM	AN	A01	A02	AP	AQ (Mounting thread)	AR (Connection port)	AS	AT	AU	AV	AW	AX	AY1	AY2	AZ	BA	BB
16 [0.630]		14	4	11.5	6	4	16	34	M4×0.7 Depth5	M5×0.8	1	7.5	12	19	5	10	5	15	11	21	13
20 [0.787]		18	4	12	7	4	18	39	M4×0.7 Depth5	M5×0.8	8	8	14	21	5	10	5	15	11	21	11
25 [0.984]		21	5	16	7.5	4	20	45	M5×0.8 Depth6	M5×0.8	11	9	16	23	5	10	5.5	15.5	12	22	9
32 [1.260]		26	6	18	10	4	24	54	M6×1 Depth8	Rc1/8	14	12	20	29	7	14	6.5	20.5	14	28	8
40 [1.575]		32	7	22	12	4	30	66	M8×1.25 Depth10	Rc1/8	17	13	22	31	7	14	8	22	17	31	10

Dimensions of Double Rod Bushing Type and Double Rod Bearing Type (mm)

XDAD Bore size × Stroke
XDAAD Bore size × Stroke

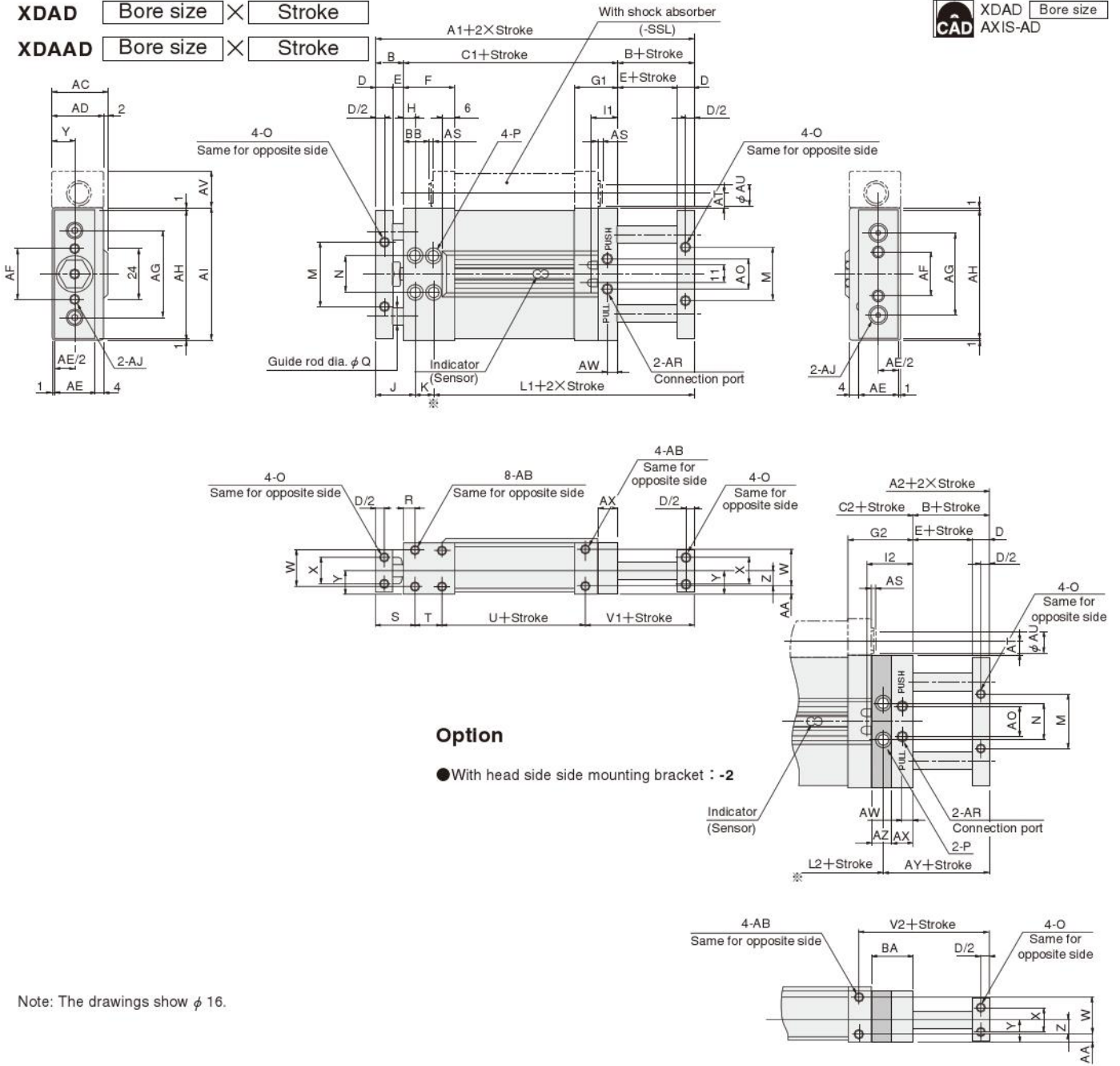

Note: The drawings show $\phi 16$.

Bore mm [In.]	Code	A1	A2	B	C1	C2	D	E	F	G1	G2	H	I1	I2	J	K	L1	L2	M	N	O (Mounting thread)
16 [0.630]		110	121	14	82	93	8	6	25	21	32	5.5	12.75	23.75	19.5	9	81.5	63.5	32	19	M4×0.7 Depth5
20 [0.787]		121	132	15	91	102	8	7	30	21	32	6	12.75	23.75	21	13	87	68	36	21	M4×0.7 Depth6
25 [0.984]		126	138	17	92	104	10	7	31	21	33	6.5	12.75	24.75	23.5	11.5	91	70.5	42	25	M5×0.8 Depth7
32 [1.260]		148	162	20	108	122	12	8	38	30	44	7.5	16.75	30.75	27.5	15	105.5	79	50	29	M6×1 Depth8
40 [1.575]		167	184	25	117	134	15	10	43	30	47	9	16.75	33.75	34	15.5	117.5	87.5	60	37	M8×1.25 Depth11

Bore mm [In.]	Code	P (Mounting hole)	Q	R	S	T	U	V1	V2	W	X	Y	Z	AA	AB (Mounting thread)	AC	AD	AE	AF
16 [0.630]		$\phi 4.5$ Counterbore $\phi 8$ Depth12	8	5.5	19.5	14	47	29.5	40.5	17	12	11	7	4	M4×0.7 Depth5	27	25	20	25
20 [0.787]		$\phi 4.5$ Counterbore $\phi 8$ Depth13	10	5.5	20.5	19	51	30.5	41.5	20	16	13	8.5	4.5	M4×0.7 Depth5	31	29	24	28
25 [0.984]		$\phi 5.5$ Counterbore $\phi 9.5$ Depth14	12	5.5	22.5	20	51	32.5	44.5	23	20	15.5	10	5.5	M5×0.8 Depth6	36	34	29	34
32 [1.260]		$\phi 6.5$ Counterbore $\phi 11$ Depth16	16	8	28	22	56	42	56	28	24	19	12.5	6.5	M6×1 Depth7	43	41	36	40
40 [1.575]		$\phi 9$ Counterbore $\phi 14$ Depth19	20	8	33	27	60	47	64	33	29	23	15	8	M8×1.25 Depth8	51	49	44	48

Bore mm [In.]	Code	AG	AH	AI	AJ (Mounting thread and mounting hole)	AO	AR (Connection port)	AS	AT	AU	AV	AW	AX	AY	AZ	BA	BB
16 [0.630]		43	62	64	M5×0.8 Inner dia. $\phi 4.3$	16	M5×0.8	1	7.5	12	19	5	10	29	11	21	13
20 [0.787]		49	72	74	M5×0.8 Inner dia. $\phi 4.3$	18	M5×0.8	8	8	14	21	5	10	30	11	21	11
25 [0.984]		57	82	84	M6×1 Inner dia. $\phi 5.3$	20	M5×0.8	11	9	16	23	5	10	32.5	12	22	9
32 [1.260]		69	102	104	M8×1.25 Inner dia. $\phi 6.8$	24	Rc1/8	14	12	20	29	7	14	40.5	14	28	8
40 [1.575]		84	122	124	M10×1.5 Inner dia. $\phi 8.5$	30	Rc1/8	17	13	22	31	7	14	47	17	31	10

Dimensions of Single Rod Long Bearing Type (mm)

XDAQ Bore size × Stroke

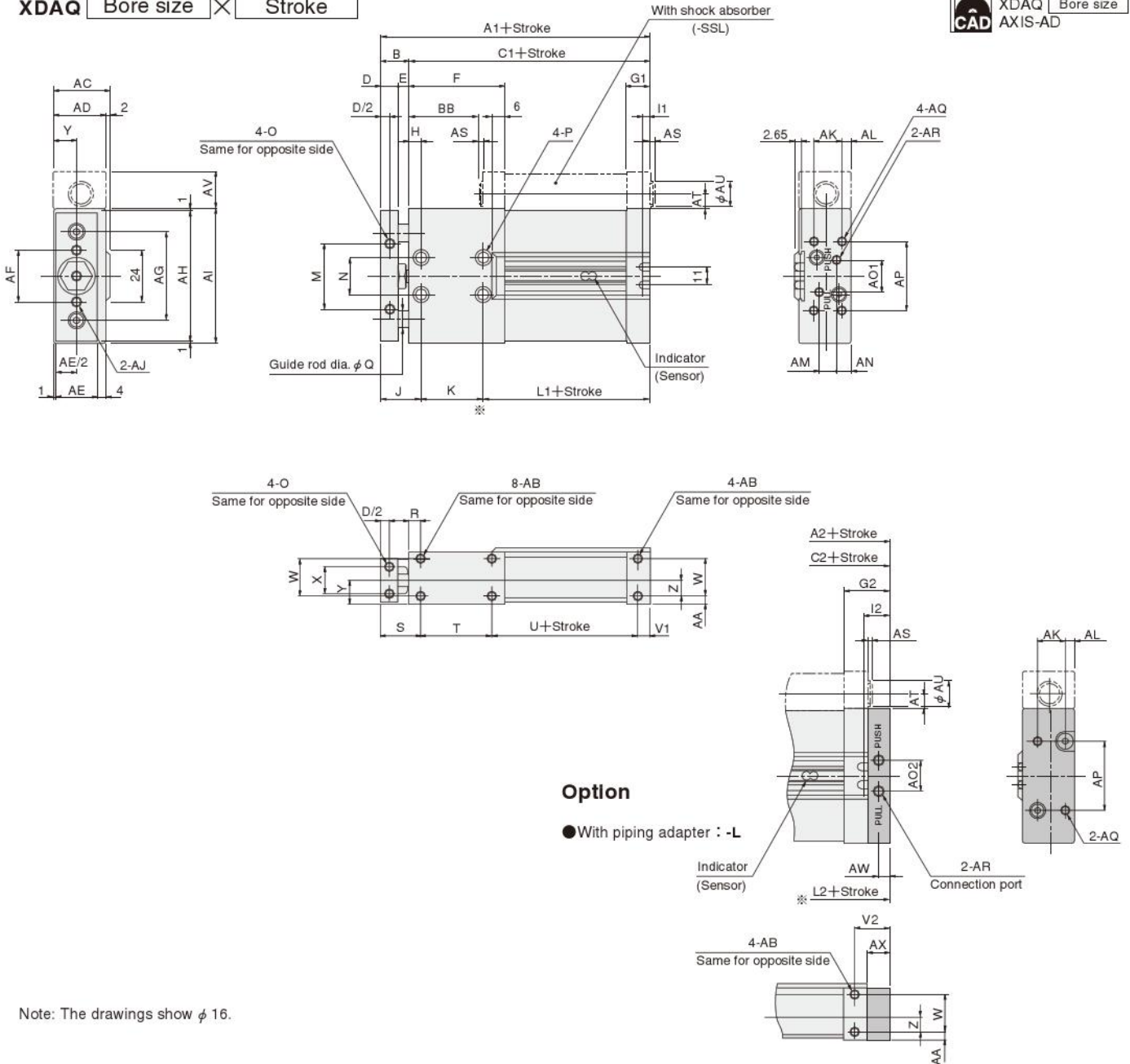

Note: The drawings show φ 16.

Bore mm [in.]	Code	A1	A2	B	C1	C2	D	E	F	G1	G2	H	I1	I2	J	K	L1	L2	M	N	O (Mounting thread)
16 [0.630]		107	117	14	93	103	8	6	46	11	21	5.5	2.75	12.75	19.5	30	57.5	67.5	32	19	M4×0.7 Depth5
20 [0.787]		122	132	15	107	117	8	7	56	11	21	6	2.75	12.75	21	39	62	72	36	21	M4×0.7 Depth6
25 [0.984]		126	136	17	109	119	10	7	58	11	21	6.5	2.75	12.75	23.5	38.5	64	74	42	25	M5×0.8 Depth7
32 [1.260]		147	161	20	127	141	12	8	71	16	30	7.5	2.75	16.75	27.5	48	71.5	85.5	50	29	M6×1 Depth8
40 [1.575]		166	180	25	141	155	15	10	81	16	30	9	2.75	16.75	34	53.5	78.5	92.5	60	37	M8×1.25 Depth11

Bore mm [in.]	Code	P (Mounting hole)	Q	R	S	T	U	V1	V2	W	X	Y	Z	AA	AB (Mounting thread)	AC	AD	AE	AF	AG	AH
16 [0.630]		φ 4.5 Counterbore φ 8 Depth12	8	5.5	19.5	35	47	5.5	15.5	17	12	11	7	4	M4×0.7 Depth5	27	25	20	25	43	62
20 [0.787]		φ 4.5 Counterbore φ 8 Depth13	10	5.5	20.5	45	51	5.5	15.5	20	16	13	8.5	4.5	M4×0.7 Depth5	31	29	24	28	49	72
25 [0.984]		φ 5.5 Counterbore φ 9.5 Depth14	12	5.5	22.5	47	51	5.5	15.5	23	20	15.5	10	5.5	M5×0.8 Depth6	36	34	29	34	57	82
32 [1.260]		φ 6.5 Counterbore φ 11 Depth16	16	8	28	55	56	8	22	28	24	19	12.5	6.5	M6×1 Depth7	43	41	36	40	69	102
40 [1.575]		φ 9 Counterbore φ 14 Depth19	20	8	33	65	60	8	22	33	29	23	15	8	M8×1.25 Depth8	51	49	44	48	84	122

Bore mm [in.]	Code	AI	AJ (Mounting thread and mounting hole)	AK	AL	AM	AN	A01	A02	AP	AQ (Mounting thread)	AR (Connection port)	AS	AT	AU	AV	AW	AX	BB
16 [0.630]		64	M5×0.8 Inner dia. φ 4.3	14	4	10	6	17	16	34	M4×0.7 Depth5	M5×0.8	1	7.5	12	19	5	10	34
20 [0.787]		74	M5×0.8 Inner dia. φ 4.3	18	4	12	7	22	18	39	M4×0.7 Depth5	M5×0.8	8	8	14	21	5	10	37
25 [0.984]		84	M6×1 Inner dia. φ 5.3	21	5	16	7.5	26	20	45	M5×0.8 Depth6	M5×0.8	11	9	16	23	5	10	36
32 [1.260]		104	M8×1.25 Inner dia. φ 6.8	26	6	18	10	33	24	54	M6×1 Depth8	Rc 1/8	14	12	20	29	7	14	41
40 [1.575]		124	M10×1.5 Inner dia. φ 8.5	32	7	22	12	42	30	66	M8×1.25 Depth10	Rc 1/8	17	13	22	31	7	14	48

Dimensions of Single Rod Long Bearing Type with Head Side Side Mounting Bracket (mm)

XDAQ Bore size × Stroke -2

 XDAQ Bore size
 AXIS-BR1
 AXIS-BR2
 AXIS-AD

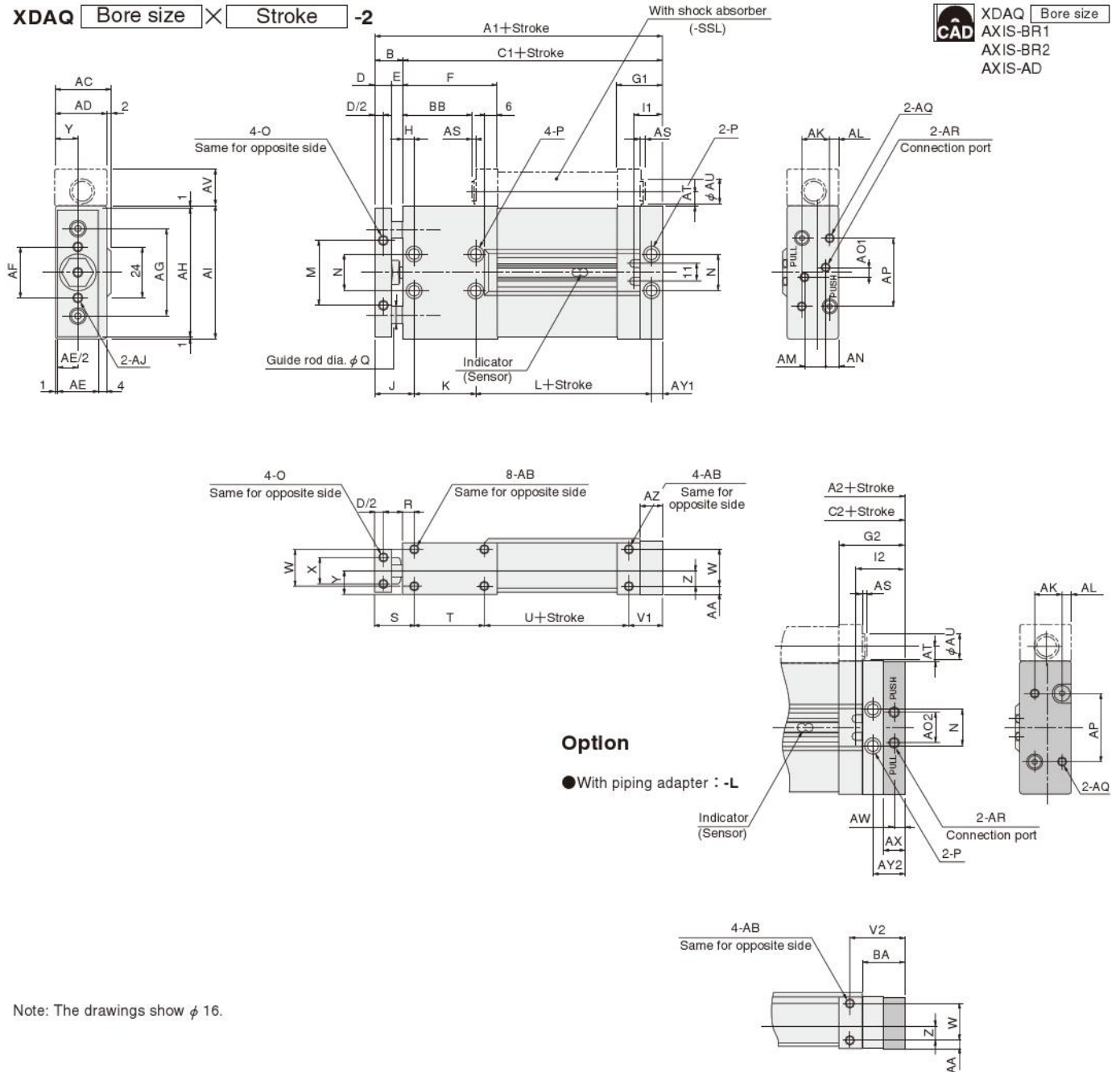

Note: The drawings show ϕ 16.

Bore mm [In.]	Code	A1	A2	B	C1	C2	D	E	F	G1	G2	H	I1	I2	J	K	L	M	N	O (Mounting thread)	P (Mounting hole)
16 [0.630]		118	128	14	104	114	8	6	46	22	32	5.5	13.75	23.75	19.5	30	63.5	32	19	M4X0.7 Depth5	ϕ 4.5 Counterbore ϕ 8 Depth12
20 [0.787]		133	143	15	118	128	8	7	56	22	32	6	13.75	23.75	21	39	68	36	21	M4X0.7 Depth6	ϕ 4.5 Counterbore ϕ 8 Depth13
25 [0.984]		138	148	17	121	131	10	7	58	23	33	6.5	14.75	24.75	23.5	38.5	70.5	42	25	M5X0.8 Depth7	ϕ 5.5 Counterbore ϕ 9.5 Depth14
32 [1.260]		161	175	20	141	155	12	8	71	30	44	7.5	16.75	30.75	27.5	48	79	50	29	M6X1 Depth8	ϕ 6.6 Counterbore ϕ 11 Depth16
40 [1.575]		183	197	25	158	172	15	10	81	33	47	9	19.75	33.75	34	53.5	87.5	60	37	M8X1.25 Depth11	ϕ 9 Counterbore ϕ 14 Depth19

Bore mm [In.]	Code	Q	R	S	T	U	V1	V2	W	X	Y	Z	AA	AB (Mounting thread)	AC	AD	AE	AF	AG	AH	AI	AJ (Mount. thread & mount. hole)
16 [0.630]		8	5.5	19.5	35	47	16.5	26.5	17	12	11	7	4	M4X0.7 Depth5	27	25	20	25	43	62	64	M5 X0.8 Inner dia. ϕ 4.3
20 [0.787]		10	5.5	20.5	45	51	16.5	26.5	20	16	13	8.5	4.5	M4X0.7 Depth5	31	29	24	28	49	72	74	M5 X0.8 Inner dia. ϕ 4.3
25 [0.984]		12	5.5	22.5	47	51	17.5	27.5	23	20	15.5	10	5.5	M5X0.8 Depth6	36	34	29	34	57	82	84	M6 X1 Inner dia. ϕ 5.3
32 [1.260]		16	8	28	55	56	22	36	28	24	19	12.5	6.5	M6X1 Depth7	43	41	36	40	69	102	104	M8 X1.25 Inner dia. ϕ 6.8
40 [1.575]		20	8	33	65	60	25	39	33	29	23	15	8	M8X1.25 Depth8	51	49	44	48	84	122	124	M10X1.5 Inner dia. ϕ 8.5

Bore mm [In.]	Code	AK	AL	AM	AN	AO1	AO2	AP	AQ (Mounting thread)	AR (Connection port)	AS	AT	AU	AV	AW	AX	AY1	AY2	AZ	BA	BB
16 [0.630]		14	4	11.5	6	4	16	34	M4X0.7 Depth5	M5X0.8	1	7.5	12	19	5	10	5	15	11	21	34
20 [0.787]		18	4	12	7	4	18	39	M4X0.7 Depth5	M5X0.8	8	8	14	21	5	10	5	15	11	21	37
25 [0.984]		21	5	16	7.5	4	20	45	M5X0.8 Depth6	M5X0.8	11	9	16	23	5	10	5.5	15.5	12	22	36
32 [1.260]		26	6	18	10	4	24	54	M6X1 Depth8	Rc1/8	14	12	20	29	7	14	6.5	20.5	14	28	41
40 [1.575]		32	7	22	12	4	30	66	M8X1.25 Depth10	Rc1/8	17	13	22	31	7	14	8	22	17	31	48

Dimensions of Double Rod Long Bearing Type (mm)

XDADQ Bore size × Stroke

CAD XDADQ Bore size
 AXIS-BR1
 AXIS-BR2

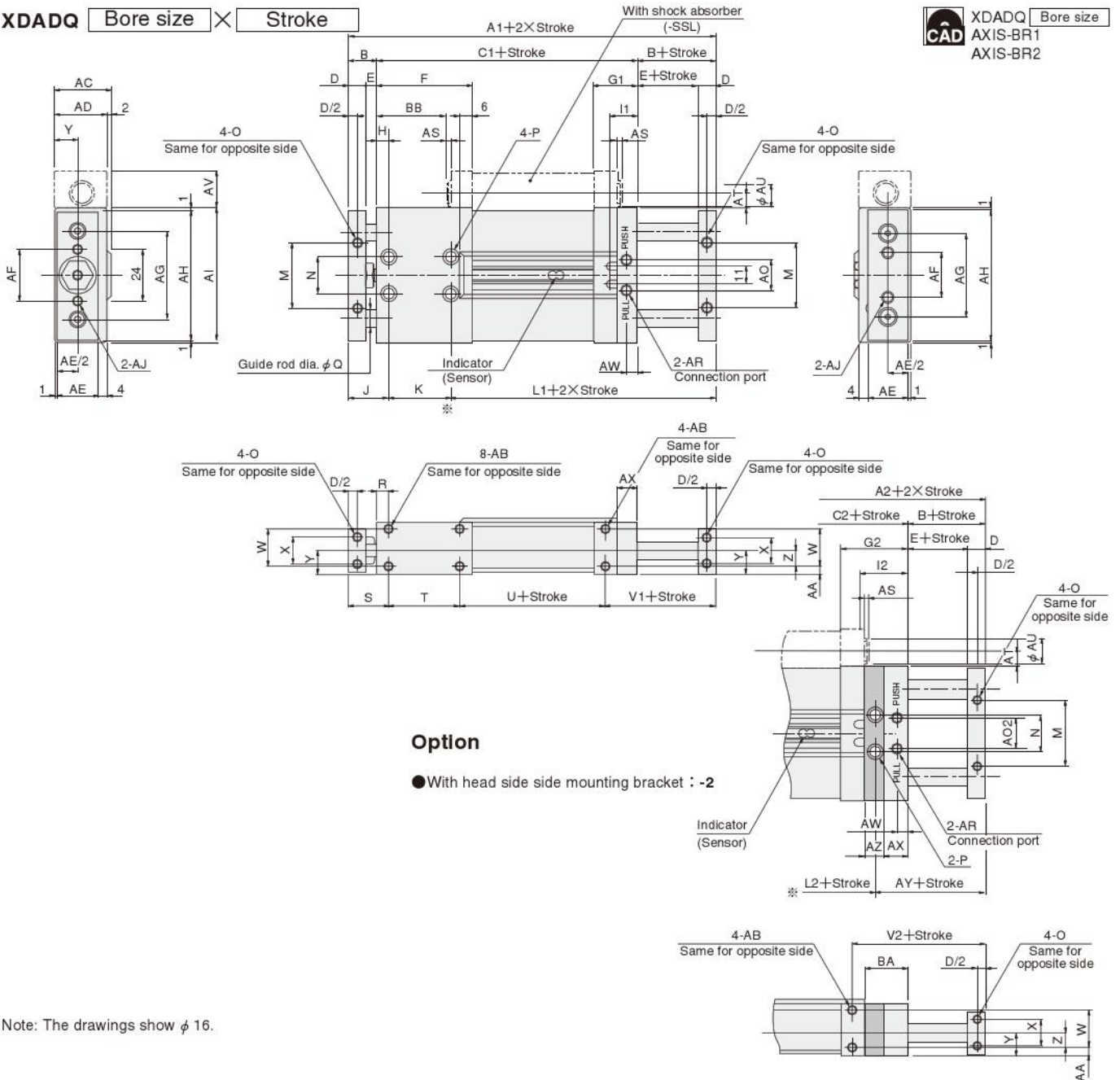

Option

- With head side side mounting bracket : -2

Note: The drawings show φ 16.

Bore mm [in.]	Code	A1	A2	B	C1	C2	D	E	F	G1	G2	H	I1	I2	J	K	L1	L2	M	N	O (Mounting thread)
16 [0.630]		131	142	14	103	114	8	6	46	21	32	5.5	12.75	23.75	19.5	30	81.5	63.5	32	19	M4×0.7 Depth5
20 [0.787]		147	158	15	117	128	8	7	56	21	32	6	12.75	23.75	21	39	87	68	36	21	M4×0.7 Depth6
25 [0.984]		153	165	17	119	131	10	7	58	21	33	6.5	12.75	24.75	23.5	38.5	91	70.5	42	25	M5×0.8 Depth7
32 [1.260]		181	195	20	141	155	12	8	71	30	44	7.5	16.75	30.75	27.5	48	105.5	79	50	29	M6×1 Depth8
40 [1.575]		205	222	25	155	172	15	10	81	30	47	9	16.75	33.75	34	53.5	117.5	87.5	60	37	M8×1.25 Depth11

Bore mm [in.]	Code	P (Mounting hole)	Q	R	S	T	U	V1	V2	W	X	Y	Z	AA	AB (Mounting thread)	AC	AD	AE	AF
16 [0.630]		φ 4.5 Counterbore φ 8 Depth12	8	5.5	19.5	35	47	29.5	40.5	17	12	11	7	4	M4×0.7 Depth5	27	25	20	25
20 [0.787]		φ 4.5 Counterbore φ 8 Depth13	10	5.5	20.5	45	51	30.5	41.5	20	16	13	8.5	4.5	M4×0.7 Depth5	31	29	24	28
25 [0.984]		φ 5.5 Counterbore φ 9.5 Depth14	12	5.5	22.5	47	51	32.5	44.5	23	20	15.5	10	5.5	M5×0.8 Depth6	36	34	29	34
32 [1.260]		φ 6.6 Counterbore φ 11 Depth16	16	8	28	55	56	42	56	28	24	19	12.5	6.5	M6×1 Depth7	43	41	36	40
40 [1.575]		φ 9 Counterbore φ 14 Depth19	20	8	33	65	60	47	64	33	29	23	15	8	M8×1.25 Depth8	51	49	44	48

Bore mm [in.]	Code	AG	AH	AI	AJ (Mounting thread and mounting hole)	AO	AR (Connection port)	AS	AT	AU	AV	AW	AX	AY	AZ	BA	BB
16 [0.630]		43	62	64	M5×0.8 Inner dia. φ 4.3	16	M5×0.8	1	7.5	12	19	5	10	29	11	21	34
20 [0.787]		49	72	74	M5×0.8 Inner dia. φ 4.3	18	M5×0.8	8	8	14	21	5	10	30	11	21	37
25 [0.984]		57	82	84	M6×1 Inner dia. φ 5.3	20	M5×0.8	11	9	16	23	5	10	32.5	12	22	36
32 [1.260]		69	102	104	M8×1.25 Inner dia. φ 6.8	24	Rc1/8	14	12	20	29	7	14	40.5	14	28	41
40 [1.575]		84	122	124	M10×1.5 Inner dia. φ 8.5	30	Rc1/8	17	13	22	31	7	14	47	17	31	48

SENSOR SWITCHES

Solid State Type, Reed Switch Type

Order Codes

				Sensor switch model	Lead wire length	Cylinder basic type
Solid state type	2-lead wire	With indicator lamp	DC10~28V	ZC630	A B	-XDA
Solid state type	3-lead wire	With indicator lamp	DC4.5~28V	ZC653		
Reed switch type	2-lead wire	Without indicator lamp	DC5~28V AC85~115V	ZC601		
Reed switch type	2-lead wire	With indicator lamp	DC10~28V	ZC605		

● For details of sensor switches, see p.1544.

● A : 1000mm [39in.]
● B : 3000mm [118in.]

Sensor Switch Operating Range, Response Differential, and Maximum Sensing Location

● Mounting location of end of stroke detection sensor switch

When a green line on the sensor switch, which shows the maximum sensing location, is installed to line up with the center of the indicator (∞ shaped-indication) built into the cylinder body, the magnet position on the end of stroke can be accurately aligned to the maximum sensing location of the sensor switch. It also facilitates fine adjustment of the end of stroke detection location.

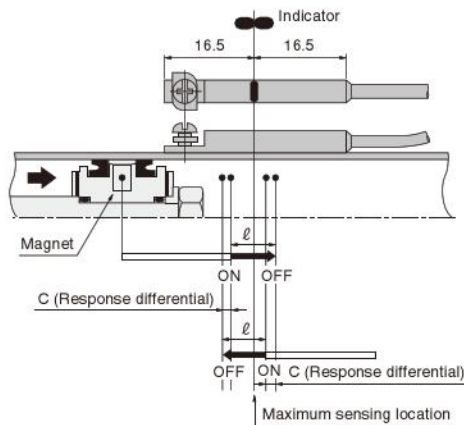

● Operating range: l

The distance the piston travels in one direction, while the switch is in the ON position.

● Response differential: C

The distance between the point where the piston turns the switch ON and the point where the switch is turned OFF as the piston travels in the opposite direction.

● Solid state type (ZC630□, ZC653□)

		mm [in.]				
		Bore size				
		16	20	25	32	40
		[0.630]	[0.787]	[0.984]	[1.260]	[1.575]
Item	Operating range l	2.8~3.4 [0.110~ 0.134]	2.7~3.4 [0.106~ 0.134]	3.0~3.7 [0.118~ 0.146]	3.0~3.8 [0.118~ 0.150]	3.3~4.0 [0.130~ 0.157]
	Response differential C	0.1 [0.004] or less		0.2 [0.008] or less	0.1 [0.004] or less	
Maximum sensing location ^{Note}		16.5 [0.650]				

● Reed switch type (ZC601□, ZC605□)

		mm [in.]				
		Bore size				
		16	20	25	32	40
		[0.630]	[0.787]	[0.984]	[1.260]	[1.575]
Item	Operating range l	7.9~11.0 [0.311~ 0.433]	7.7~11.0 [0.303~ 0.433]	8.0~11.0 [0.315~ 0.433]	7.6~10.6 [0.299~ 0.417]	8.0~11.5 [0.315~ 0.453]
	Response differential C	1.6 [0.063] or less		1.9 [0.075] or less	1.8 [0.071] or less	1.9 [0.075] or less
Maximum sensing location ^{Note}		16.5 [0.650]				

Note: This is a value measured from the cable side end surface.
Remark: The above table shows reference values.

Mounting/Removing and Moving Sensor Switch

The following is a summary for mounting/removing and moving AXIS cylinder sensor switches.

■ Removing the sensor cover

- ① Push the lead wire holder in either direction.

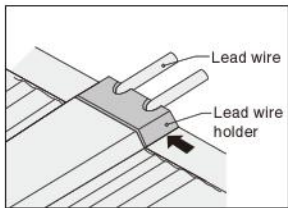

- ② While pushing, pull up and remove the lead wire holder.

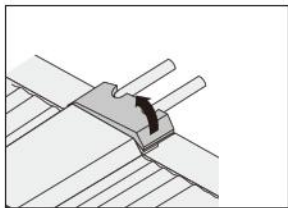

- ③ Pull out the sensor cover in the direction of the arrow until it comes to a stop (about 5mm).

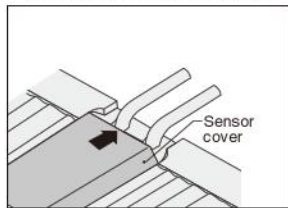

- ④ Take hold of one corner of the pulled-out sensor cover, and pull up to remove it.

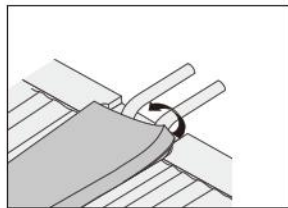

■ Moving the sensor switch

- ① Loosen the mounting screw of the sensor switch, and move the sensor switch along the cylinder body's switch groove. Note

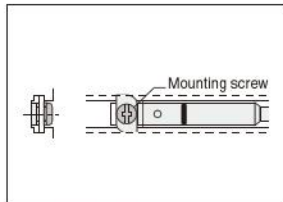

Note: Set the tightening torque of the mounting screw to 0.2N·m [1.8in·lbf]. When loosening the mounting screw, do not turn the mounting plate more than one-fourth of a turn.

- ② To remove the sensor switch, loosen the mounting screw, lower the mounting plate and rotate it until it faces in the direction shown in the diagram, and remove it in the direction of the arrow.

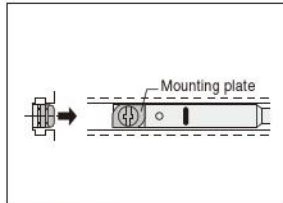

Note: When loosening mounting screw, do not turn it more than one and a half turns. It might damage the crimping of the screw.

■ Mounting the sensor cover

- ① Once moving, adjusting, and securing of the sensor switch has been completed, attach the sensor cover as shown in the diagram.

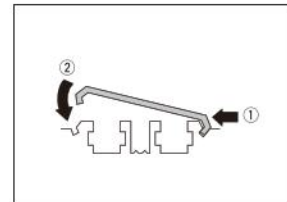

- ② To secure the sensor switch lead wire, place the lead wire holder in a groove, press on one end of the lead wire holder, and then press down to secure it in place.

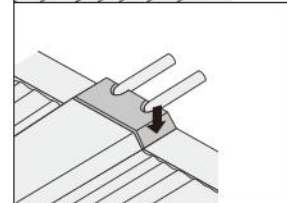
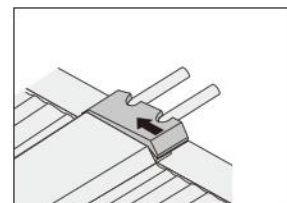

Caution When Cylinder with Sensor Switch Is Installed

When mounting in close proximity to a multiple number of AXIS cylinders with sensor switches, maintain the mounting intervals shown in the table to avoid mutual magnetic interference.

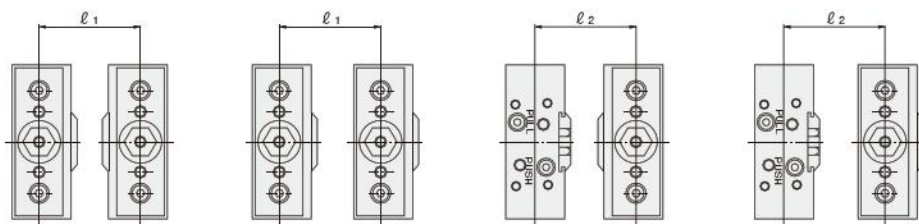

Bore size mm [in.]	l_1 mm [in.]	l_2 mm [in.]
16 [0.630]	110 [4.33] or more	50 [1.97] or more
20 [0.787]	110 [4.33] or more	50 [1.97] or more
25 [0.984]	110 [4.33] or more	60 [2.36] or more
32 [1.260]	120 [4.72] or more	60 [2.36] or more
40 [1.575]	120 [4.72] or more	60 [2.36] or more

Sensor switches can be faced outward, as shown to the right, to mount 2 AXIS cylinders.

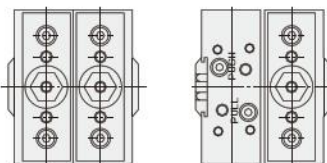

Remark : The above table shows reference values.

SHOCK ABSORBERS

KSHAX Series
Compatible with AXIS Cylinder

Specifications

Item \ Model	KSHAX6×5	KSHAX7×5	KSHAX8×6	KSHAX10×8	KSHAX12×10
Applicable cylinder bore size mm [in.]	16 [0.630]	20 [0.787]	25 [0.984]	32 [1.260]	40 [1.575]
Maximum absorption J [ft·lbf]	1.5 [1.1]	2.0 [1.5]	2.9 [2.1]	6.9 [5.1]	11.8 [8.7]
Absorbing stroke mm [in.]	5 [0.197]	5 [0.197]	6 [0.236]	8 [0.315]	10 [0.394]
Maximum impact speed mm/s [in./sec.]	700 [27.6]				
Maximum operating frequency cycle/min	60				
Operating temperature range °C [°F]	0~60 [32~140]				
Mass kg [lb.]	0.018 [0.040]	0.033 [0.073]	0.045 [0.099]	0.084 [0.185]	0.107 [0.236]

Order Codes for Shock Absorbers Only

■ Shock absorbers for AXIS cylinder

Applicable cylinder bore size mm [in.]	Maximum absorption J [ft·lbf]	Basic type	Piston dia.×Stroke
16 [0.630]	1.5 [1.1]	KSHAX	6×5
20 [0.787]	2.0 [1.5]		7×5
25 [0.984]	2.9 [2.1]		8×6
32 [1.260]	6.9 [5.1]		10×8
40 [1.575]	11.8 [8.7]		12×10

Dimensions of Shock Absorber

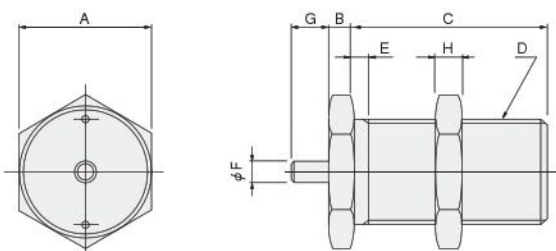

		mm							
Code \ Model	A	B	C	D	E	F	G (Stroke)	H	
KSHAX6×5	14	3	19	M12×1	1.5	3	5	3	
KSHAX7×5	17	3	26	M14×1	2	3	5	4	
KSHAX8×6	19	3	28	M16×1.5	3	3	6	4	
KSHAX10×8	22	3	37	M20×1.5	3	5	8	4	
KSHAX12×10	24	3	40	M22×1.5	3	5	10	4	

Handling Instructions and Precautions



Mounting and stroke adjustment

Mounting

1. While any mounting direction is allowed, the mounting surface should always be flat. Twisting or bending during mounting may disturb the accuracy and may also result in air leaks or improper operation.
2. Care should be taken that scratches or dents on the cylinder's mounting surface may damage its flatness.
3. The joint between the rod end plate and the piston rod has a certain degree of clearance (0.1~0.2mm [0.004~0.008in.]). Always confirm that joint nut A and joint nut B (see the inner construction on p.849) are secured before commencing cylinder operation.

Stroke adjustment

In the AXIS cylinder with shock absorber type, the stroke is adjustable within the range of values listed in the specifications on p.848. To adjust to a shorter stroke, first remove the shock absorber cover, then loosen the shock absorber's lock nut and turn the shock absorber to the left (counterclockwise). After adjusting, tighten the lock nut and secure it in place.

Although the shock absorber can be moved further than is shown in the specifications on p.848, turning it too far could exceed the strength of the thread and damage the thread and the stopper. Therefore, do not adjust the stroke beyond the values listed in the specifications on p.848. Moreover, the strokes cannot be adjusted further than the standard strokes.

In addition, if the stopper must be moved to adjust the stroke, set the tightening torque of the stopper's hexagon socket head bolt at the values in the table below.

At shipping, the stopper is already adjusted to the standard stroke.

Bore size mm [in.]	16 [0.630]	20 [0.787]	25 [0.984]	32 [1.260]	40 [1.575]
Tightening torque N·cm [in·lbf]	137.3±14.7 [12.2±1.3]	284.4±29.4 [25.2±2.6]	480.5±49 [42.5±4.3]	1196.4±117.7 [105.9±10.4]	

How to remove the shock absorber cover

With short-stroke cylinders, hold the center of the cover. With long-stroke cylinders, place hands on each end. Then apply force in the direction of the arrow ① and lift the cover from the groove.

Next, apply force in the direction of the arrows ②, rotating the cover mainly from diagonal corners, and remove it.

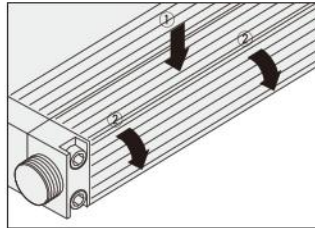

Piping adapter, mounting bracket

For only the single rod type, an order for a piping adapter and mounting bracket alone can be placed.

Order codes

Piping adapter

L-XDA

(One piping adapter, 2 bolts, and 1 gasket are supplied)

Mounting bracket

2-XDA

(One mounting bracket, 2 bolts, and 1 gasket are supplied)



Sensor switch

1. In all AXIS cylinders, the magnet for sensor switch is built-in.
2. Consult us when mounting 2 sensor switches on cylinders with 10mm [0.394in.] strokes or less.
3. The sensor cover cannot be attached when 3 or more sensor switches have been mounted. Moreover, it cannot be mounted so as to protrude from the sensor switch mounting groove.
4. For mounting/removing and moving sensor switches, see p.862.



General precautions

1. Always thoroughly blow off (use compressed air) the tubing before piping. Entering chips, sealing tape, rust, etc., generated during piping work could result in air leaks or other defective operation.
2. Use air for the media. For the use of any other media, consult us.
3. The product cannot be used when the media or ambient atmosphere contains any of the substances listed below.
Organic solvents, phosphate ester type hydraulic oil, sulphur dioxide, chlorine gas, or acids, etc.
4. If using in locations subject to dripping water, dripping oil, etc., or to large amounts of dust, use a cover to protect the unit.