

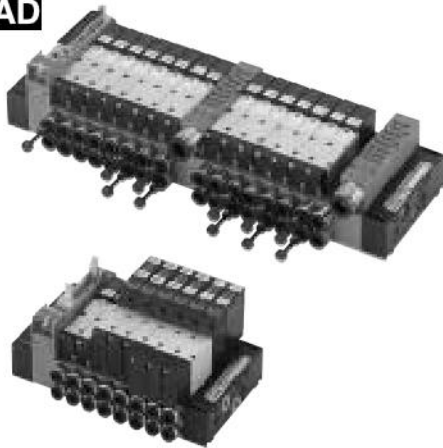

CAD drawing data catalog  
is available.



# KOGANEI

## VALVES GENERAL CATALOG

# FM-SOLID MANIFOLD X80M SERIES INDEX

FM-SOLID MANIFOLD X80M SERIES

Module Configuration	383
Examples of FM-SOLID MANIFOLD X80M Configuration	385
Module Mass and Dimensions	387
Manifold Order Codes	388
Module Order Codes	391
Wiring Modules	393
Details of Wiring Specifications	394
Detailed Diagram of Solenoid Wiring System	396
Dimensions	397
Compact Serial Transmission System	399
Piping Modules	403
Dimensions	404
Valve Modules	405
Cylinder Operating Speed, Flow Rate	406
Dimensions	407
Block-off Plate Module	412
Dimensions	413
End Blocks	414
Dimensions	415
Handling Instructions and Precautions	417
Important Precautions	418



**Caution**

Before use, be sure to read the "Safety Precautions" on p. 31.

# FM-SOLID MANIFOLD X80M Series Module Configuration

## Wiring modules, p.393

### Flat cable connector type



● Accommodates up to 8 solenoids (10 pins)



● Accommodates up to 16 solenoids (20 pins)

### D-sub connector type

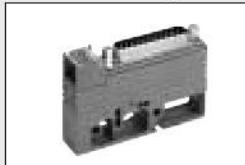

### Terminal block type



## Compact serial transmission system, p.399



For OMRON  
SYSBUS Wire System

For OMRON  
CompoBus/S

For OMRON  
B7A Link Terminal

For Mitsubishi Electric  
MELSECNET/MINI-S3

For Mitsubishi Electric  
MELSEC I/O LINK

For Mitsubishi Electric  
CC-Link

For Fuji Electric FA  
Components & Systems  
T Link Mini

For NKE, KURODA  
PRECISION INDUSTRIES  
UNI-WIRE® System

For SUNX  
S-LINK

For KEYENCE  
KZ-R

For KOYO ELECTRONICS  
INDUSTRIES  
SA Bus

※UNI-WIRE® System is a serial parallel transmission system developed jointly by NKE and KURODA PRECISION INDUSTRIES.



For OMRON  
CompoBus/D

## Piping modules, p.403

### Built-in quick fitting type



Built-in straight quick fitting



Built-in elbow quick fitting

### P port female thread type

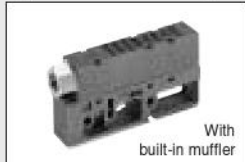

### All port female thread type



Cable assembly  
p.1039



Connector  
p.1040

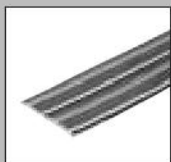

Cable  
p.1040





Remote control  
box, p.1041

● For details of specifications for modules and accessories, etc., see the pages following each title.

● For the FM-SOLID MANIFOLD X80M series order codes, see p.388.

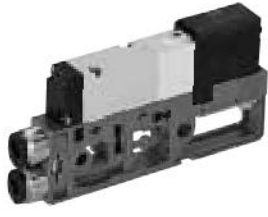
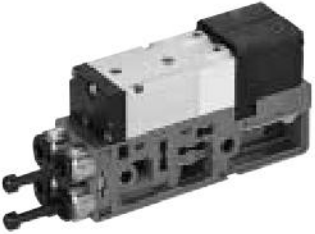
Valve modules (2-, 3-port, 5-port), p.405

Solenoid valves 090 series	
Single solenoid	
Single solenoid	
Twin solenoid	
Tandem solenoid	

● Voltage: DC12V, DC24V

Block-off plate module, p.412

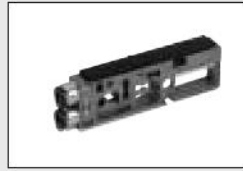

End blocks, p.414

End block module type



With DIN rail mounting bracket type



End block side piping type



End block upper piping type

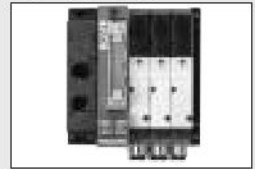

Sticker, p.388

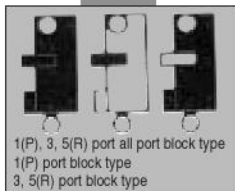

1(P), 3, 5(R) port all port block type  
1(P) port block type  
3, 5(R) port block type

Port isolator, p.388

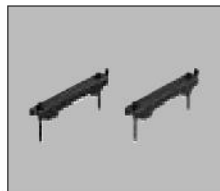

DIN rail mounting bracket, p.388

# Examples of FM-SOLID MANIFOLD X80M Configuration

## Manifold Configuration Example 1.

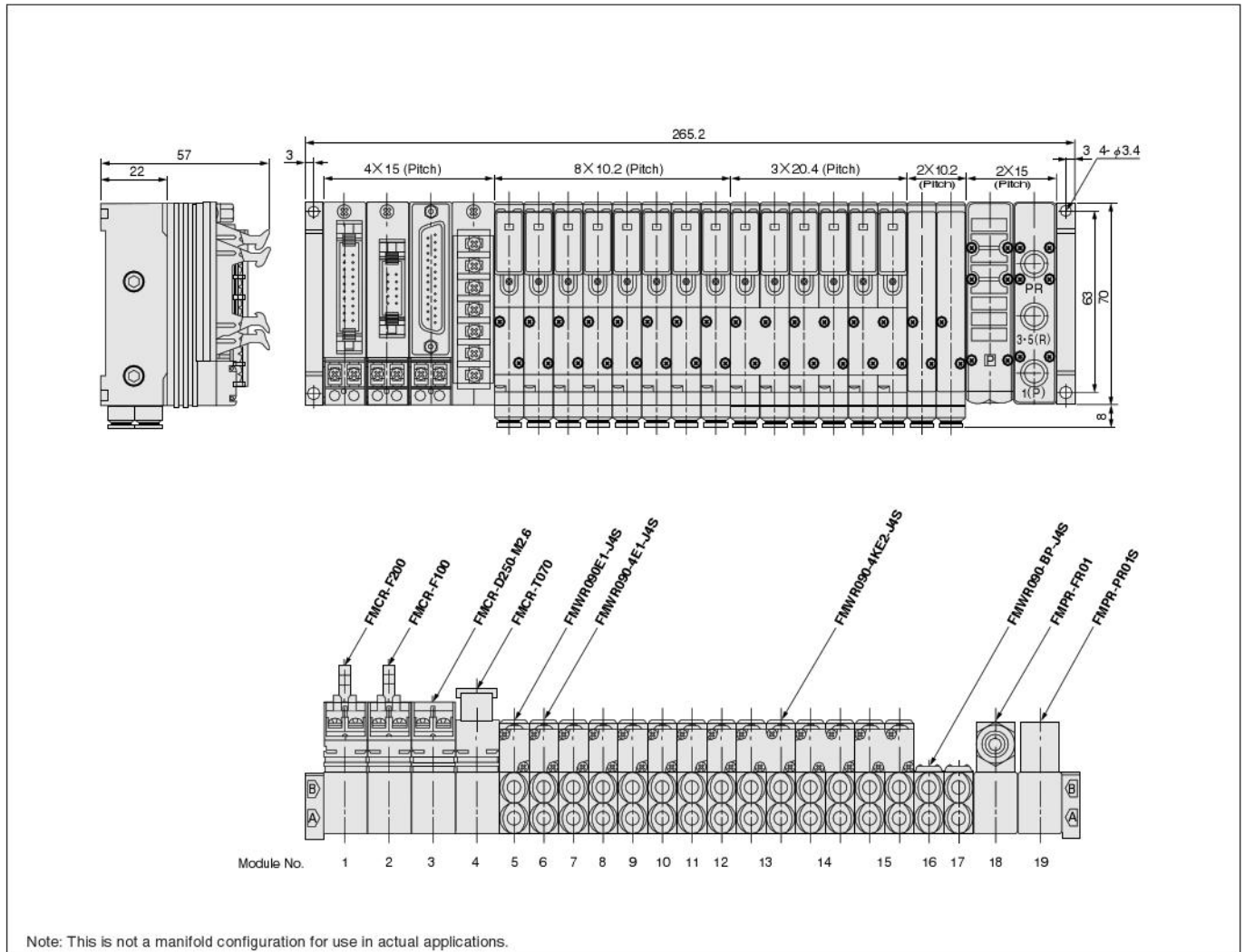

Module No.	Model
No.1	FMCR-F200
No.2	FMCR-F100
No.3	FMCR-D250-M2.6
No.4	FMCR-T070
No.5	FMWR090E1-J4S
No.6~12	FMWR090-4E1-J4S
No.13~15	FMWR090-4KE2-J4S
No.16~17	FMWR090-BP-J4S
No.18	FMPR-FR01
No.19	FMPR-PR01S

## Manifold Configuration Example 2.

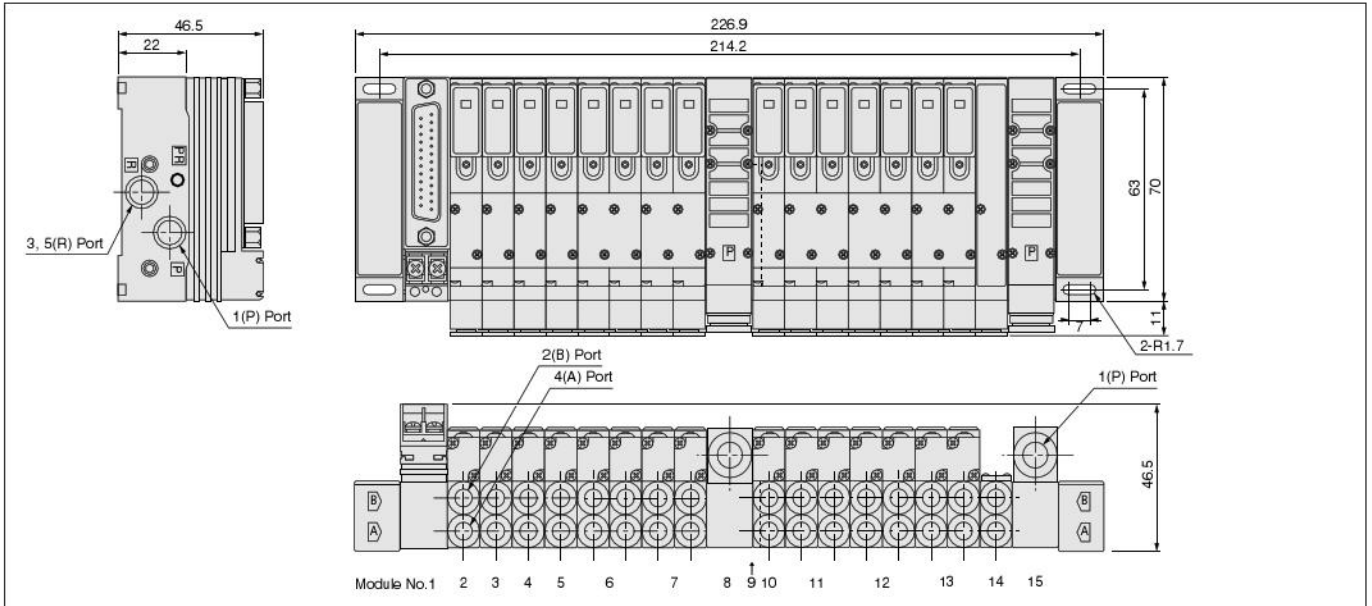

FM-SOLID MANIFOLD X80M SERIES

- Order code: X80M-ED
- No.1 FMCR-D250-M2.6 DC24V
  - No.2 FMWR090E1-J6S DC24V
  - No.3~5 FMWR090-4E1-J6S DC24V
  - No.6~7 FMWR090-4KE2-J6S DC24V
  - No.8 FMPR-FJ8S
  - No.9 FMBR-P
  - No.10 FMWR090-4E1-J6S DC24V
  - No.11~13 FMWR090-4KE2-J6S DC24V
  - No.14 FMWR090-BP-J6S
  - No.15 FMPR-FJ8S

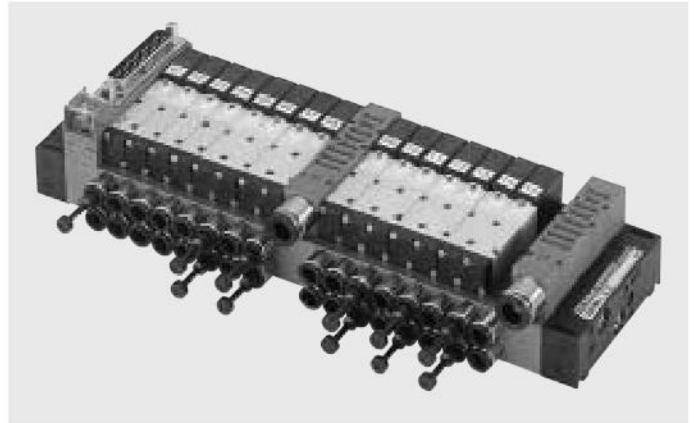

## Manifold Configuration Example 3. Combination Mounting of Single Solenoid Valves and Tandem Solenoid Valves

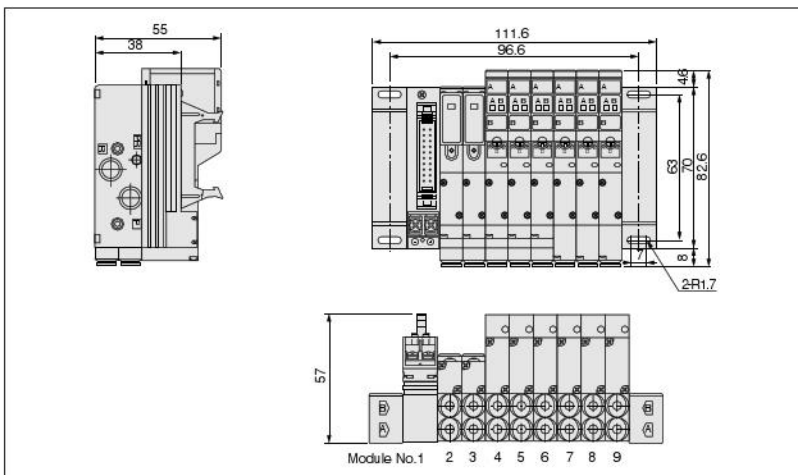

Order code: X80M-ED

- No.1 FMCR-F200 DC24V
- No.2 FMWR090-4E1-J4S DC24V
- No.3 FMWR090-4E1-J4S-D DC24V
- No.4~6 FMWR090-4ME2-81-J4S DC24V
- No.7~9 FMWR093-4ME2-81-J4S DC24V

# Module Mass and Dimensions

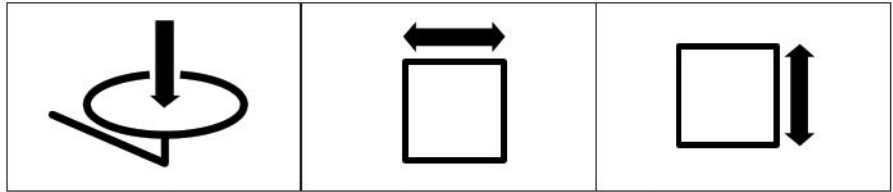

Module type	Item	Mass g [oz.]	Width mm [in.]	Height mm [in.]
Wiring module	FMCR-F10□	30 [1.06]	15 [0.59]	57 [2.24]
	FMCR-F20□	38 [1.34]	15 [0.59]	57 [2.24]
	FMCR-D250-□	44 [1.55]	15 [0.59]	46 [1.81]
	FMCR-G250-□	51 [1.80]	15 [0.59]	46 [1.81]
	FMCR-T070	37 [1.31]	15 [0.59]	50 [1.97]
Compact serial transmission block	YS101□/YS102□	80/65 [2.82/2.29]	30.6 [1.205]	66.9 [2.634]
	YS111□,YS121□,YS161□,YS171□	105 [3.70]	30.6 [1.205]	66.9 [2.634]
	YS181□,YS1A1□,YS1A2□	105 [3.70]	30.6 [1.205]	66.9 [2.634]
	YS131□,YS132□,YS1B1□	100 [3.53]	30.6 [1.205]	66.9 [2.634]
	YS141□/YS142□	85/70 [3.00/2.47]	30.6 [1.205]	66.9 [2.634]
	YS151□/YS152□	70/67 [2.47/2.36]	30.6 [1.205]	66.9 [2.634]
Piping module	FMPR-FJ8S	36 [1.27]	15 [0.59]	39 [1.54]
	FMPR-FJ8L	42 [1.48]	15 [0.59]	55.4 [2.181]
	FMPR-FR01	37 [1.31]	15 [0.59]	39 [1.54]
	FMPR-PR01S	50 [1.76]	15 [0.59]	40.5 [1.594]
Valve module	FMWR090E1	42 [1.48]*	10.2 [0.402]	36 [1.42]*
	FMWR090-4E1	42 [1.48]*	10.2 [0.402]	36 [1.42]*
	FMWR090-4KE2	84 [2.96]*	20.4 [0.803]	36 [1.42]*
	FMWR090-4ME2	62 [2.19]*	10.2 [0.402]	55.8 [2.197]
	FMWR093-4ME2	67 [2.36]*	10.2 [0.402]	55.8 [2.197]
Block-off plate module	FMWR090-BP	24 [0.85]*	10.2 [0.402]	23.6 [0.929]
End block	X80M	30 [1.06]	6 [0.24]	22.5 [0.886]
	X80M-ER	47 [1.66]	Left side 6 [0.24]/Right side 17 [0.67]	22.5 [0.886]
	X80M-EL	47 [1.66]	Left side 17 [0.67]/Right side 6 [0.24]	22.5 [0.886]
	X80M-ED	64 [2.26]	Left side 17 [0.67]/Right side 17 [0.67]	22.5 [0.886]
	X80M-UR	80 [2.82]	Left side 6 [0.24]/Right side 15 [0.59]	39 [1.54]
	X80M-UL	80 [2.82]	Left side 15 [0.59]/Right side 6 [0.24]	39 [1.54]
	X80M-UD	130 [4.59]	Left side 15 [0.59]/Right side 15 [0.59]	39 [1.54]
	X80M-DN	118 [4.16] (88 [3.10]) <sup>Note</sup>	Left side 12.7 [0.500]/Right side 12.7 [0.500]	31 [1.22]

Remark: The heights are those with the end blocks installed.

※: For -J4S

Note: Figures in parentheses ( ) are the mass for the DIN rail mounting bracket only.



<b>X80M-DN</b>	30+88=118
<b>No.1 FMCR-F100 DC24V</b>	30×1 =30
<b>No.2~9 FMWR090-4E1-J4S DC24V</b>	42×8 =336
<b>No.10 FMPR-FJ8S</b>	36×1 =36
118+30+336+36=520g [18.34oz.]	

## FM-SOLID MANIFOLD X80M Series Basic Specifications

Item	Manifold basic model	X80M
Media		Air
Operating pressure range	MPa {kgf/cm <sup>2</sup> } [psi.]	0.2 ~ 0.7 {2.0 ~ 7.1} [29 ~ 102]
Proof pressure	MPa {kgf/cm <sup>2</sup> } [psi.]	1.05 [10.7] [152]
Operating temperature range (atmosphere and media)	°C [°F]	5 ~ 50 [41 ~ 122]
Wiring type		Collective wiring type from wiring module (Flat cable connector type, D-sub connector type, terminal block type)
End block		End block module type/End block piping type
Manifold mounting type		Direct mounting type/DIN rail mounting type
Common terminal wiring		Positive common/Negative common

# Manifold Order Codes

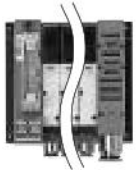
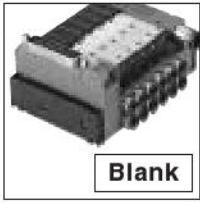
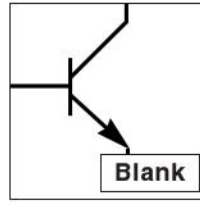
## Order Codes

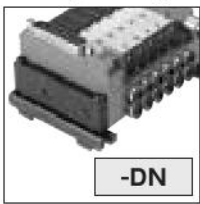
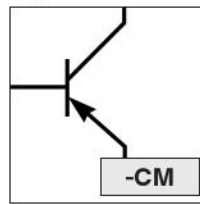
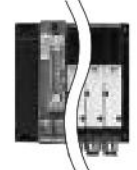
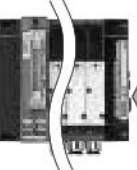
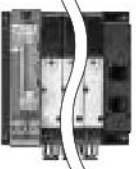
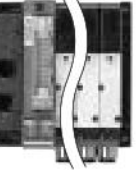
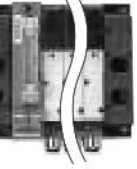
Manifold basic model	End block type	Mounting type	Common terminal wiring	Module No.	Module model
<b>X80M</b>	<b>-ED</b>	<b>-DN</b>	<b>-CM</b>	<b>No.1</b>	<b>- FMCR-F200...</b>
	↓	↓	↓	↓	
End block shape		End block mounting type		Positive common	
<p><b>Blank</b></p>  <p>① <b>End block module type</b> Always specify the piping module. (1(P) and 3, 5(R) ports are plumbed at the piping module.)</p>		 <p style="text-align: center;"><b>Blank</b></p>		 <p style="text-align: center;"><b>Blank</b></p>	<p style="text-align: center;">No.2</p> <p style="text-align: center;">⋮</p> <p style="text-align: center;">No.n</p> <p style="text-align: center;">-</p> <ul style="list-style-type: none"> <li>● Select from the valve modules, wiring modules, or piping modules.</li> <li>● One sticker is provided for each manifold.</li> </ul>
<p><b>-ER</b></p>  <p>② <b>End block right side piping type</b> 1(P), 3, 5(R), and PR piping is possible at the end block. The piping direction is lateral right (← direction). 1(P), 3, 5(R) ports: 1/8 PR port: M5 PR port is separated.</p>		<p style="text-align: center;">With DIN rail mounting bracket type</p>  <p style="text-align: center;"><b>-DN</b></p>		<p style="text-align: center;">Negative common</p>  <p style="text-align: center;"><b>-CM</b></p>	<ol style="list-style-type: none"> <li>1. The number of the modules for the FM-SOLID MANIFOLD X80M series should be 20 stations or less.</li> <li>2. When a pressure drop is considered possible, such as when a multiple number of valves are operated simultaneously on a multi-station manifold, or during high cycle applications, add a piping module at an intermediate position of the manifold.</li> <li>3. When combining 2 or more terminal block type wiring modules (<b>FMCR-T070</b>) side by side, the wiring space for each terminal block becomes tight. Depending on the wiring types and conditions, each wiring group's crimped terminals or lead wires could interfere with other terminal blocks, and it could be difficult to achieve an orderly wiring. When using multiple wiring modules, therefore, carefully study the designated locations of each module or consult us.</li> </ol>
<p><b>-EL</b></p>  <p>③ <b>End block left side piping type</b> Same specification as the above ②. The piping direction, however, is lateral left (→ direction).</p>					
<p><b>-ED</b></p>  <p>④ <b>End block both sides piping type</b> Same specification as the above ②. The piping direction, however, can be in both lateral directions.</p>					
<p><b>-UR</b></p>  <p>⑤ <b>End block upper right side piping type</b> 1(P) and 3, 5(R) piping is possible at the end block. The piping direction is upward right. 1(P) and 3, 5(R) ports: 1/8 (3, 5(R) and PR share the same 3, 5(R) port)</p>					
<p><b>-UL</b></p>  <p>⑥ <b>End block upper left side piping type</b> Same specification as the above ⑤. The piping direction, however, is upward left.</p>					
<p><b>-UD</b></p>  <p>⑦ <b>End block upper both sides piping type</b> Same specification as the above ⑤. The piping direction, however, can be in both upward directions.</p>					

### Order codes for additional parts (To be ordered separately)

- DIN rail mounting bracket (1 set)
- Number stickers (1 set of 5 sheets)

**X801-DN**



**X802-01**



### About a port isolator

Use of a port isolator at an intermediate position on the manifold and installing a piping module to an individual group makes the use of 2 or 3 different pressures possible, and prevents exhaust interference from the main exhaust. When ordering, enter a port isolator as 1 module.

Port isolator type	Type	Function
<b>FMBR-A</b>	1(P), 3, 5(R) port all port block	
<b>FMBR-P</b>	1(P) port block	
<b>FMBR-R</b>	3, 5(R) port block	

※Although port isolators can be installed into modules at any location, they cannot be disassembled to change the position after shipping.

# Manifold Order Codes (With Compact Serial Transmission Block)

## Order Codes

Manifold basic model: **X80MS1**

Compact serial transmission block: Manufacturer's specification, Mounting location

End block type: **EL**

Mounting type: **DN**

Module No. **No.1** - **FMWR090-4ME2...**

**No.n** - [ ]

**01** : For UNI-WIRE System (16 outputs)  
**02** : For UNI-WIRE System (8 outputs)  
**11** : For Mitsubishi Electric MELSECNET/MINI-S3  
**21** : For OMRON SYSBUS Wire System  
**31** : For OMRON B7A Link Terminal (standard)  
**32** : For OMRON B7A Link Terminal (high speed)  
**41** : For KOYO ELECTRONICS INDUSTRIES SA Bus (16 outputs)  
**42** : For KOYO ELECTRONICS INDUSTRIES SA Bus (8 outputs)  
**51** : For SUNX S-LINK (16 outputs)  
**52** : For SUNX S-LINK (8 outputs)  
**61** : For Mitsubishi Electric MELSEC I/O LINK  
**71** : For Fuji Electric FA Components & Systems T Link Mini  
**81** : For KEYENCE KZ-R  
**A1** : For OMRON CompoBus/S (16 outputs)  
**A2** : For OMRON CompoBus/S (8 outputs)  
**B1** : For Mitsubishi Electric CC-Link

**L**: Left side mounting  
**R**: Right side mounting

**Blank**: End block mounting type  
**DN**: With DIN rail mounting bracket type

**Blank**: End block module type  
**EL**: End block left side piping type  
**ER**: End block right side piping type  
**UL**: End block upper left piping type  
**UR**: End block upper right piping type

Note: A piping type end block cannot be designated for the same side as the compact serial transmission block mounting location. When selecting an end block piping type, see the table below:

○: Mounting possible    ×: Mounting impossible

End block type	EL	ER	UL	UR
Mounting location of the compact serial transmission block	<b>L</b>	×	○	×
	<b>R</b>	○	×	×

- Select from the valve modules, piping modules, or block-off plate modules.
- For the voltage specifications of the valve module, always select DC24V.

Note

### Order codes for compact serial transmission block only

### Order code for dedicated cable for S-LINK only

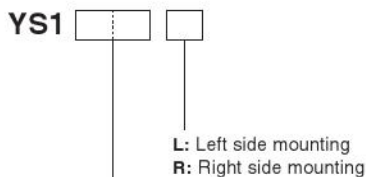

**YS151-KB2**  
 (Cable length: 2000mm [79in.])

- 01** : For UNI-WIRE System (16 outputs)  
**02** : For UNI-WIRE System (8 outputs)  
**11** : For Mitsubishi Electric MELSECNET/MINI-S3  
**21** : For OMRON SYSBUS Wire System  
**31** : For OMRON B7A Link Terminal (standard)  
**32** : For OMRON B7A Link Terminal (high speed)  
**41** : For KOYO ELECTRONICS INDUSTRIES SA bus (16 outputs)  
**42** : For KOYO ELECTRONICS INDUSTRIES SA bus (8 outputs)  
**51** : For SUNX S-LINK (16 outputs)  
**52** : For SUNX S-LINK (8 outputs)  
**61** : For Mitsubishi Electric MELSEC I/O LINK  
**71** : For Fuji Electric FA Components & Systems T Link Mini  
**81** : For KEYENCE KZ-R  
**A1** : For OMRON CompoBus/S (16 outputs)  
**A2** : For OMRON CompoBus/S (8 outputs)  
**B1** : For Mitsubishi Electric CC-Link

※ Order them for maintenance use only.  
 Internal wiring and mounting screws, etc. are not included.

## Order Codes for Serial Transmission System for OMRON CompoBus/D

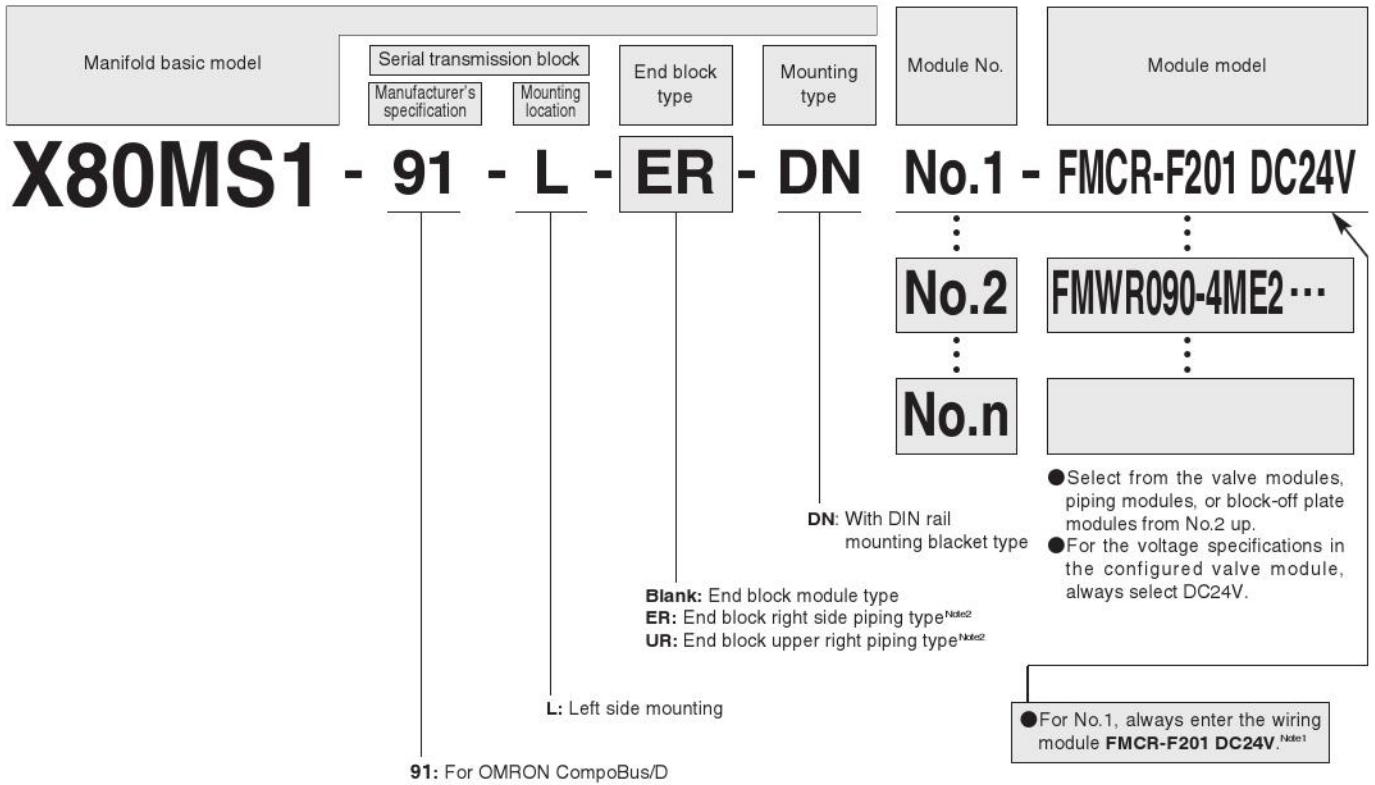

FM-SOLID MANIFOLD X80M SERIES

Notes: 1. Since the shape and wiring configuration for the OMRON CompoBus/D differs from those of other serial transmission types, a wiring module is required as module No.1. For module No.1, always enter wiring module **FMCR-F201 DC24V**.  
 2. With the end block type, **EL** and **UL** cannot be selected.

### Order code for serial transmission block only

**YS391**

**91:** For OMRON CompoBus/D

※Order it for maintenance use only.  
 Mounting screws, etc. are not included.

# Module Order Codes

## Wiring Module Order Codes

Wiring connecting specification	Wiring module basic type	Wiring basic type	Voltage	
Flat cable connector	FMCR	-F100	DC12V	
		-F101 <sup>Note 1</sup>		
-F200				
-F201 <sup>Note 2</sup>				
D-sub connector		-D250	-M2.6,-M3,-UNC <sup>Note 3</sup>	DC24V
		-G250 <sup>Note 4</sup>		
Terminal block		-T070		

■ Mounting threads for D-sub connector  
M2.6 thread: -M2.6  
M3 thread: -M3  
#4-40-UNC thread: -UNC

Notes: 1. -F100 and -F101 differ only in pin locations, and both can be used with up to 8 solenoids. For details, see p.394.  
2. -F200 and -F201 differ only in pin locations, and both can be used with up to 16 solenoids. For details, see p.394.  
3. When using the cable assembly (FMA-AD250-□), always select -M2.6.  
4. For the D-sub connector specifications when a tandem solenoid valve is mounted, always designate -G250.  
Remark: For wiring module specifications, see p.393.

## Piping Module Order Codes

Piping module basic type	Port specification	Fitting specification	Port size	Piping direction
FMPR	1(P) port built-in quick fitting type (with built-in muffler on 3, 5(R) port): -FJ 1(P) port female thread type (with built-in muffler on 3, 5(R) port): -FR All port female thread type: -PR	Straight quick fitting for $\phi$ 8 tube: 8S Elbow quick fitting for $\phi$ 8 tube: 8L	Rc1/8: 01	Upper piping: S
	-FJ	8S, 8L		
	-FR		01	S
	-PR			

Remark: For piping module specifications, see p.403.

※ The FM-SOLID MANIFOLD X80M series is compatible with the following specifications;

- Pressure switch (electronic type) module
- Wiring module (D-sub connector, side connection specification)
- CS specification
- External pilot specification

For details of specifications, delivery time, etc., consult us.

## Valve Module Order Codes

		■ 2-, 3-port valve Number of ports 3-port: <b>Blank</b> 2-port: <b>-2</b>	■ 2-, 3-port valve Valve function Normally closed (NC): <b>Blank</b> Normally open (NO): <b>-11</b>	■ 3-position valve Valve function Closed center: <b>Blank</b> Exhaust center: <b>-13</b> Pressure center: <b>-14</b>	■ Manual override Non-locking type: <b>Blank</b> Locking type: <b>-81</b>	■ Module base 4(A), 2(B) ports, port specification φ 4 straight quick fitting : <b>-J4S</b> φ 4 long straight quick fitting : <b>-J4LS</b> φ 6 straight quick fitting : <b>-J6S</b> φ 4 elbow quick fitting : <b>-J4U</b> M5 female thread type : <b>-M5M</b>	■ Wiring type Wiring for single solenoid: <b>Blank</b> Wiring for tandem solenoid : <b>-D</b>	■ Common terminal wiring Positive common: <b>Blank</b> Negative common: <b>-CM</b>	■ Voltage
Base piping type module	Valve module basic model	090E1	-2	-11	-81	-J4S, -J4LS <sup>Note 1</sup> , -J6S, -J4U <sup>Note 3</sup> , -M5M	-D <sup>Note 4</sup>	-CM	DC12V DC24V
Base piping type module (tandem solenoid)	FMWR	090-4E1							
		090-4KE2							
		090-4ME2			-81 <sup>Note 2</sup>				
		093-4ME2		-13, -14					
Order codes for single valve unit	F1WR	090E1	-2	-11	-81				DC12V DC24V
		090-4E1							
		090-4KE2							
		090-4ME2			-81 <sup>Note 2</sup>				
		093-4ME2		-13, -14					

- Notes: 1. For combination mounting of the straight quick fitting φ 4 and φ 6 specification modules, select the long straight quick fitting (-J4LS) for the φ 4 specification. The protruding dimensions of both fittings become the same.
2. Always enter **-81**.
3. A 3-position tandem solenoid valve cannot be mounted on the **-J4U** valve module.
4. Even if the valve mounted at shipping is a single solenoid, 2 control wires (SOL.A, SOL.B) are connected to the base interior, the same as for a tandem solenoid. If later changed to mount a tandem solenoid valve, only the valve needs to be changed, and the wiring in the base interior does not need to be changed. But since the wiring module exclusively uses the control pin corresponding to SOL.B, when ordering, pay particular attention to the wiring module's maximum number of mountable solenoids, pin number and corresponding SOL. When selecting a tandem solenoid valve module, there is no need to enter **-D**. See the pin number and corresponding solenoid on p.395.

Remark: For valve module specifications, see p. 405.

### Option

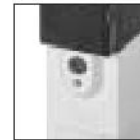

- Manual override Locking type: **-81**

## Block-off Plate Module Order Codes

		■ Module base 4(A), 2(B) ports connection specification φ 4 straight quick fitting : <b>-J4S</b> φ 4 long straight quick fitting : <b>-J4LS</b> φ 6 straight quick fitting : <b>-J6S</b> φ 4 elbow quick fitting : <b>-J4U</b> M5 female thread type : <b>-M5M</b>	■ Wiring type Wiring for single solenoid: <b>Blank</b> Wiring for tandem solenoid: <b>-D</b>	■ Common terminal wiring Positive common: <b>Blank</b> Negative common: <b>-CM</b>	
Block-off plate module basic model	FMWR	090-BP	-J4S, -J4LS <sup>Note 1</sup> , -J6S, -J4U <sup>Note 2</sup> , -M5M	-D <sup>Note 3</sup>	-CM <sup>Note 4</sup>

- Notes: 1. For combination mounting of the straight quick fitting φ 4 and φ 6 specification modules, select the long straight quick fitting (-J4LS) for the φ 4 specification. The protruding dimensions of both fittings become the same.
2. A 3-position tandem solenoid valve cannot be mounted on the block-off plate module with **-J4U**.
3. Select **-D** when planning to add on a tandem solenoid valve later. Two control wires (SOL.A and SOL.B) are connected to the base interior. When ordering, pay attention to the wiring module's maximum number of mountable solenoids, pin number and corresponding SOL. In addition, for future use to provide an additional single solenoid valve or twin solenoid valve, leave it blank. See the pin number and corresponding solenoid on p.395.
4. For mounting tandem solenoid valves, consult us.

Remark: For block-off plate module specifications, see p.412.

### Order code for block-off plate only

**F1WR090-BP**

# FM-SOLID MANIFOLD LD X80M SERIES

## Wiring Modules

### Features

Achieves space savings and enables lower costs by reducing wiring man-hours.

### Flat cable connector type

The range of the module includes a type with a 10-pin flat cable connector capable of controlling up to eight solenoids, and one with a 20-pin flat cable connector capable of controlling up to 16 solenoids. Two types of pin locations are available for the wiring.

### D-sub connector type

A 25-pin D-sub connector can accommodate up to 16 solenoids. Various kinds of cables and connectors are also provided to simplify wiring connections.

The FMCR-G250 is a dedicated wiring module for mounting tandem solenoid valves.

### Terminal block type

A terminal block with 7 terminals can accommodate up to 6 solenoids.

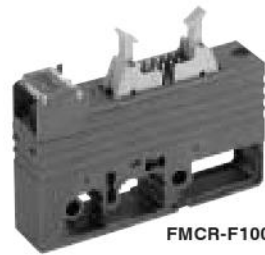

FMCR-F100



FMCR-F200



FMCR-D250



FMCR-T070

## Wiring Module Specifications

Wiring module model	Wiring connection specification	Remarks
FMCR-F100 FMCR-F101	Flat cable connector type	Made by Sumitomo 3M Box type, with long clip Part number: 4210-00MILCSC
FMCR-F200 FMCR-F201	Flat cable connector type	Made by Sumitomo 3M Box type, with long clip Part number: 4220-00MILCSC
FMCR-D250-M2.6 FMCR-D250-M3 FMCR-D250-UNC	D-sub connector type	Mounting threads for D-sub connector -M2.6: M2.6 thread -M3: M3 thread -UNC: #4-40-UNC thread
FMCR-G250-M2.6 FMCR-G250-M3 FMCR-G250-UNC	D-sub connector type	Mounting threads for D-sub connector -M2.6: M2.6 thread -M3: M3 thread -UNC: #4-40-UNC thread
FMCR-T070	Terminal block type	Terminal block thread: M3

## Module Mass

g [oz.]

Type	Mass
FMCR-F10□	30 [1.06]
FMCR-F20□	38 [1.34]
FMCR-D250-□	44 [1.55]
FMCR-G250-□	51 [1.80]
FMCR-T070	37 [1.31]

## Details of Wiring Specifications

### Number of Solenoids Which Can Be Connected to a Wiring Module (Possible Number of Connections)

(1 solenoid for 4E1 type, and 2 solenoids for 4KE2 type)

Wiring module model	Number of solenoids	Number of pins (terminals)
FMCR-F100	8	10 pins
FMCR-F101		
FMCR-F200	16	20 pins
FMCR-F201		
FMCR-D250-M2.6	16	25 pins
FMCR-D250-M3		
FMCR-D250-UNC		
FMCR-G250-M2.6	16	25 pins
FMCR-G250-M3		
FMCR-G250-UNC		
FMCR-T070	6	7 terminals

### Solenoid Layout

	Pin number
Flat cable connector (-F100) (-F101)	① ② ③ ④ ⑤ ⑥ ⑦ ⑧
D-sub connector (-D250) (-G250)	① ② ③ ④ ⑤ ⑥ ⑦ ⑧ ⑨ ⑩ ⑪ ⑫ ⑬ ⑭ ⑮ ⑯ ⑰ ⑱
Flat cable connector (-F201)	① ② ③ ④ ⑤ ⑥ ⑦ ⑧ ⑨ ⑩ ⑪ ⑫ ⑬ ⑭ ⑮ ⑯ ⑰ ⑱
Terminal (-T070)	① ② ③ ④ ⑤ ⑥

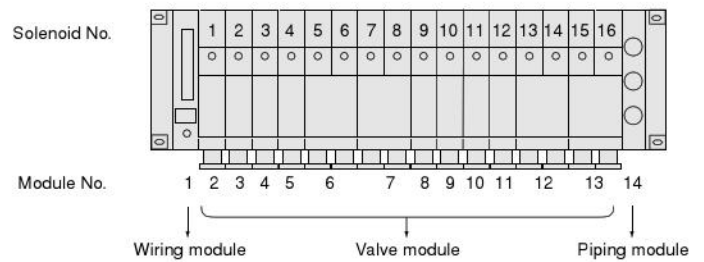

### Wiring Module Pin (Terminal) Locations

#### ● FMCR-F100

Flat cable connector

Triangle mark

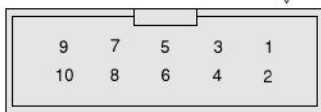

1~8: Control pins  
9, 10: Common pins (short-circuited within the module)

#### ● FMCR-F201

Flat cable connector

Triangle mark

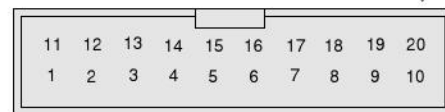

1~8: Control pins  
11~18: Control pins  
9, 19: (-) pins (short-circuited within the module)  
10, 20: (+) pins (short-circuited within the module)

#### ● FMCR-F101

Flat cable connector

Triangle mark

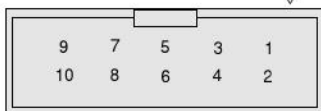

1~8: Control pins  
9: (-) pin  
10: (+) pin

#### ● FMCR-D250,G250

D-sub connector



1~16: Control pins  
20, 21, 22: (-) pins (short-circuited within the module)  
23, 24, 25: (+) pins (short-circuited within the module)

Notes: 1. The above pin numbers are assigned based on the solenoid valve wiring sequence for the sake of convenience.  
2. The D-sub connector differs from the pin locations and numbers (marked) defined in JIS X5101 for the data circuit-terminating equipment (DCE). Caution should be exercised.

#### ● FMCR-F200

Flat cable connector

Triangle mark

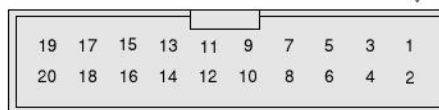

1~16: Control pins  
17, 18: (-) pins (short-circuited within the module)  
19, 20: (+) pins (short-circuited within the module)

#### ● FMCR-T070

Terminal block

Solenoid side

A, B port side



1~6: Control terminals  
7: Common terminal

The flat cable connector and D-sub connector pin locations can be adapted to specifications other than those listed above.

## Details of Wiring Specifications

### ● Pin number and corresponding solenoid (for combination mounting of single solenoid valves and tandem solenoid valves)

X80M-ED

No.1-FMCR-F200 DC24V

No.2-FMWR090-4E1-J4S DC24V

No.3-FMWR090-4E1-J4S-D DC24V

No.4~6-FMWR090-4ME2-81-J4S DC24V

No.7~9-FMWR093-4ME2-81-J4S DC24V

Pin locations

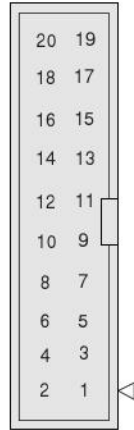
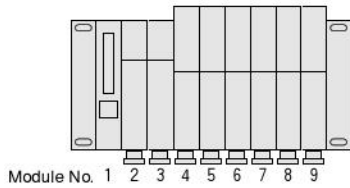

Pin No. : 1	SOL.A	} First solenoid valve: Single solenoid (wiring as single solenoid)
2	SOL.A	
3	(SOL.B) <sup>Note 1</sup>	} Second solenoid valve: Single solenoid (wiring as tandem solenoid: <b>-D</b> ) <sup>Note 2</sup>
4	SOL.A	
5	SOL.B	} Third solenoid valve: Tandem solenoid
6	SOL.A	
7	SOL.B	} 4th solenoid valve: Tandem solenoid
:	:	
14	SOL.A	} 8th solenoid valve: Tandem solenoid
15	SOL.B	
16	Not used	
17,18	(-) pins	
19,20	(+) pins	

Note 1: (SOL.B) shows that the wiring module control pin is assigned and the wire is connected to the valve base interior.

Note 2: Even if the valve mounted at shipping is a single solenoid, 2 control wires (SOL.A., SOL.B.) are connected to the base interior, the same as for a tandem solenoid. If later changed to mount a tandem solenoid valve, only the valve needs to be changed, and the wiring in the base interior does not need to be changed. But since the wiring module exclusively uses the control pin corresponding to SOL.B. when ordering, pay particular attention to the wiring module's maximum number of mountable solenoids, pin number and corresponding SOL. When selecting a tandem solenoid valve module, there is no need to enter **-D**.

### ● Pin number and corresponding solenoid (FMCR-G250-□)

X80M

No.1 -FMCR-G250-M2.6 DC24V

No.2,3-FMWR090-4ME2-81-J6S DC24V

No.4~7-FMWR090-4E1-J6S-D DC24V

No.8-FMWR090-BP-J6S-D DC24V

No.9-FMPR-FJ8S

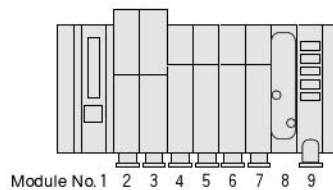

Pin locations

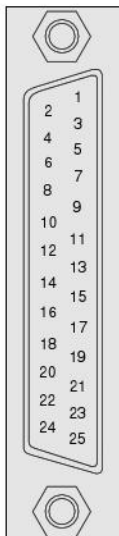

Pin No. : 1	SOL.A	} First solenoid valve: Tandem solenoid
2	B	
3	A	} Second solenoid valve: Tandem solenoid
4	B	
5	SOL.A	} Third solenoid valve: Single solenoid
6	(SOL.B) <sup>Note</sup>	
7	SOL.A	} 4th solenoid valve: Single solenoid
8	(SOL.B) <sup>Note</sup>	
:	:	
13	(SOL.A) <sup>Note</sup>	} Block-off plate
14	(SOL.B) <sup>Note</sup>	
:	:	
20,21,22	(-) pins	
23,24,25	(+) pins	

Note: (SOL.A) (SOL.B) show that the control pins in the wiring module are assigned and the wires to SOL.A and SOL.B are connected to the valve base interior.

# Detailed Diagram of Solenoid Wiring System

## Flat cable connector and D-sub connector

### ● Positive common

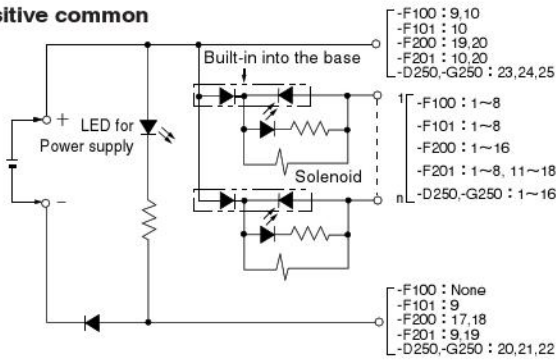

### ● Negative common

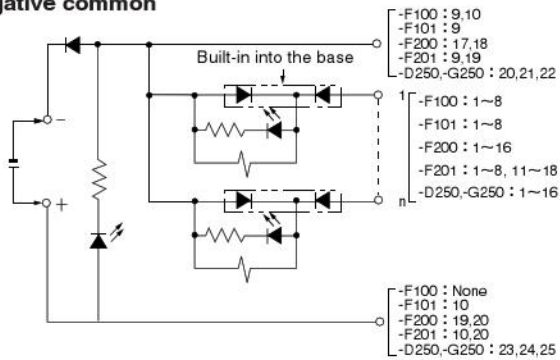

## Terminal block

### ● Positive common

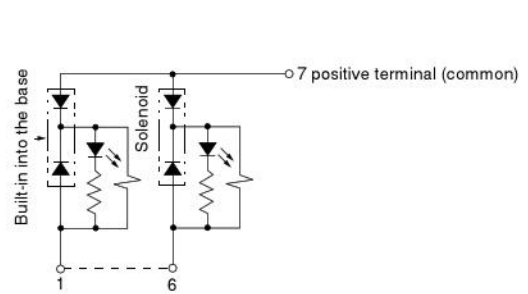

### ● Negative common

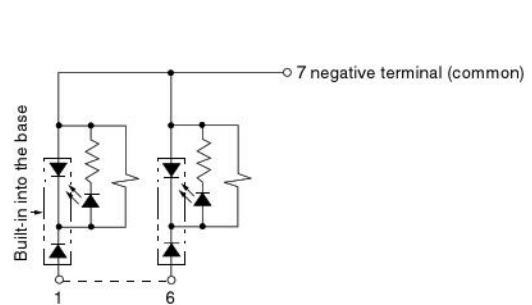

The flat cable connector and D-sub connector pin locations can be adapted to specifications other than those listed above.

# FMCR Dimensions of Wiring Module (mm)

※Height with end block attached is +1mm [0.039in.] longer than indicated below.



## Flat cable connector type FMCR-F100/-F101

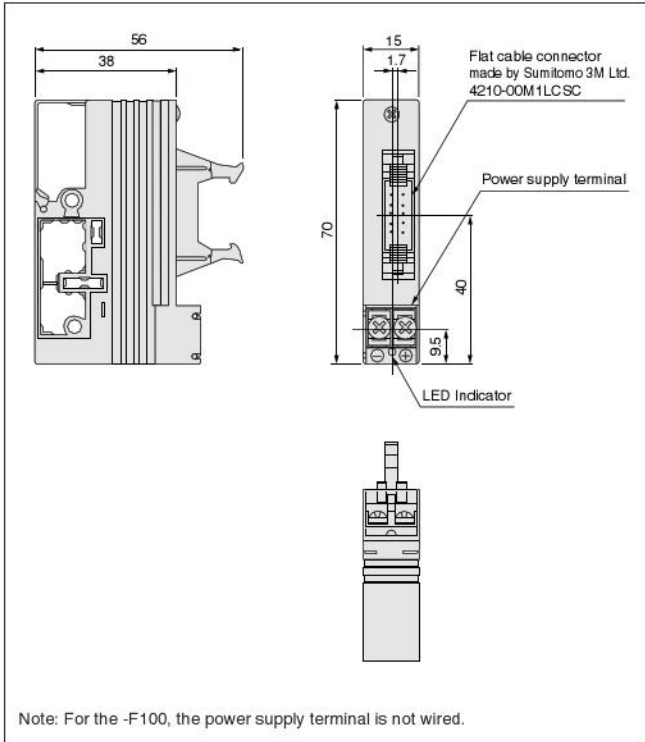

## Flat cable connector type FMCR-F200/-F201

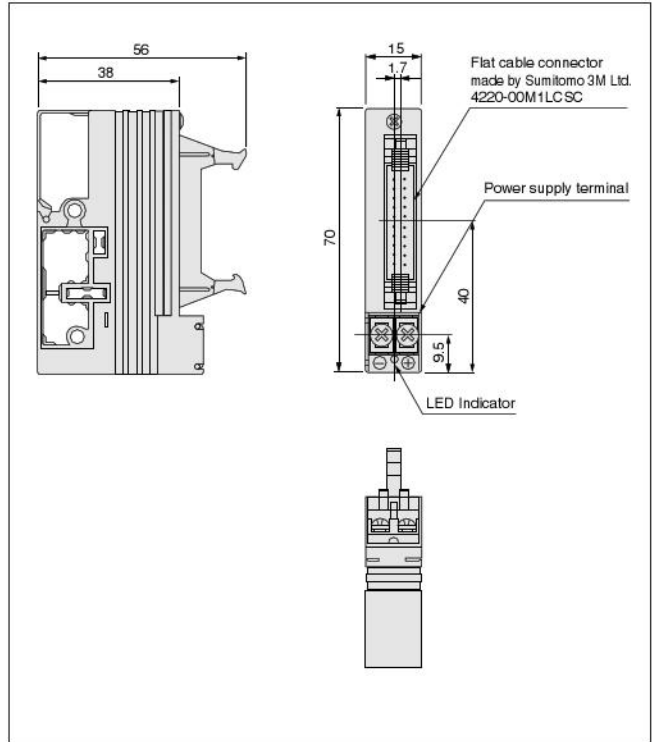

## D-sub connector type FMCR-D250-M2.6/-M3/-UNC

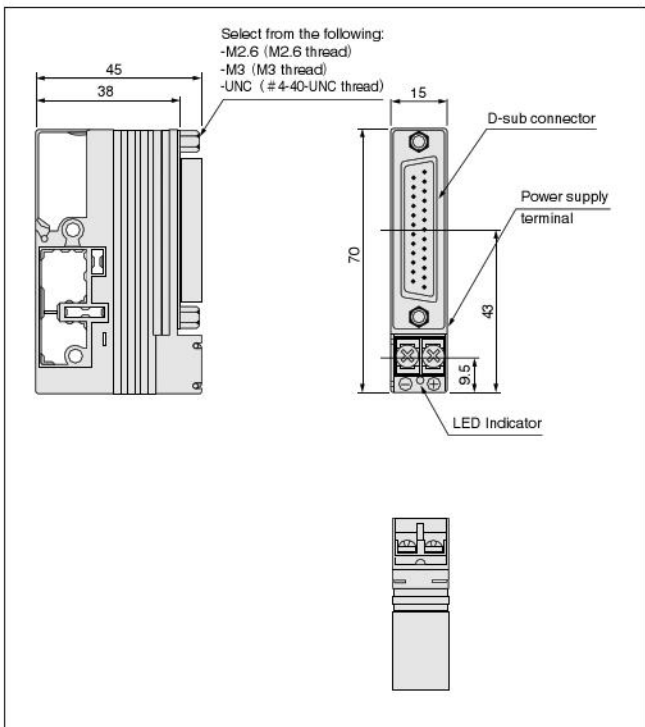

## D-sub connector type FMCR-G250-M2.6/-M3/-UNC

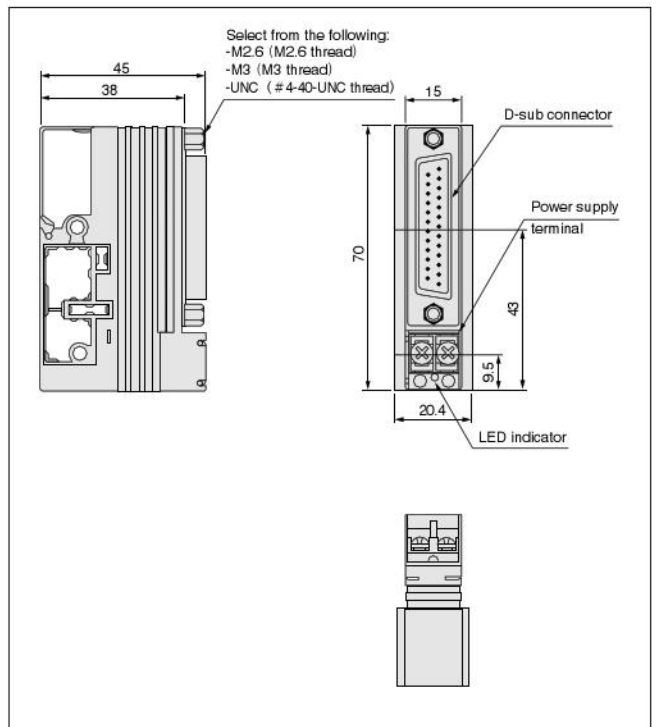

# FMCR Dimensions of Wiring Module (mm)

※Height with end block attached is +1mm [0.039in.] longer than indicated below.



## Terminal block type FMCR-T070

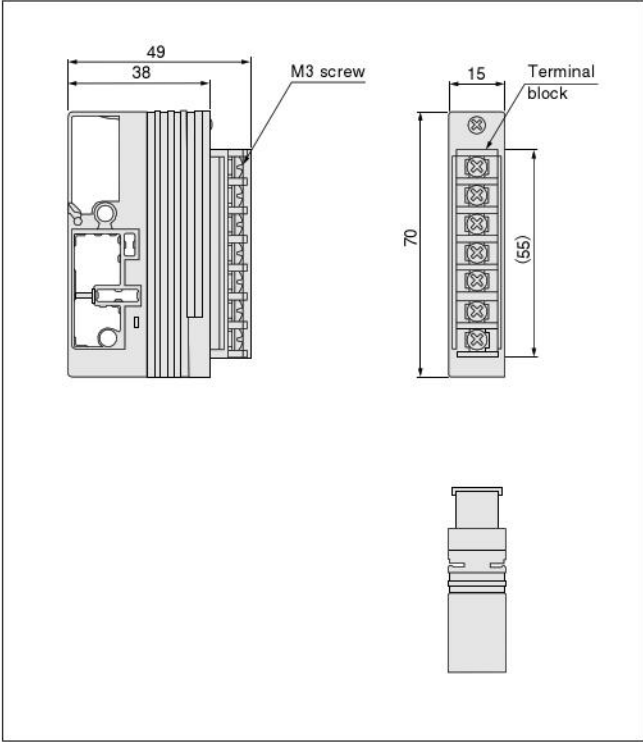

# FM-SOLID MANIFOLD X80M SERIES Compact Serial Transmission System

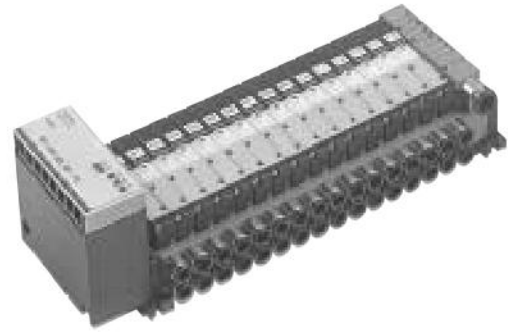

## Features

A manifold with compact serial transmission block, corresponding to each manufacturer's serial transmission system.

For OMRON SYSBUS Wire System

For OMRON CompoBus/S

For OMRON CompoBus/D <sup>Note</sup>

For OMRON B7A Link Terminal

For NKE,  
KURODA PRECISION INDUSTRIES UNI-WIRE® System

For SUNX S-LINK

For Mitsubishi Electric MELSECNET/MINI-S3

For Mitsubishi Electric MELSEC I/O LINK

For Mitsubishi Electric CC-Link

For Fuji Electric FA Components & Systems T Link Mini

For KEYENCE KZ-R

For KOYO ELECTRONICS INDUSTRIES SA Bus

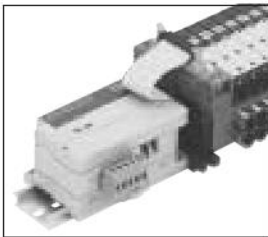

Note: OMRON's remote I/O adapter-type **DRT1-OD16X** is used in the serial transmission block for OMRON's CompoBus/D. For details, see OMRON's catalog, user's manual, etc.

- Remarks:
1. The UNI-WIRE® system is a serial parallel transmission system developed jointly by NKE and KURODA PRECISION INDUSTRIES.
  2. For the details of each system, see each manufacturer's catalog, user's manual, etc.
  3. For details on handling the corresponding manifolds, see the corresponding Koganei user's manuals.

## Example of Manifold Configuration for Compact Serial Transmission System (mm)

### Configuration Example1

#### X80MS1-A1-L

No.1~8 - FMWR090-4ME2-81-J4S DC24V

No.9 - FMPR-PR01S

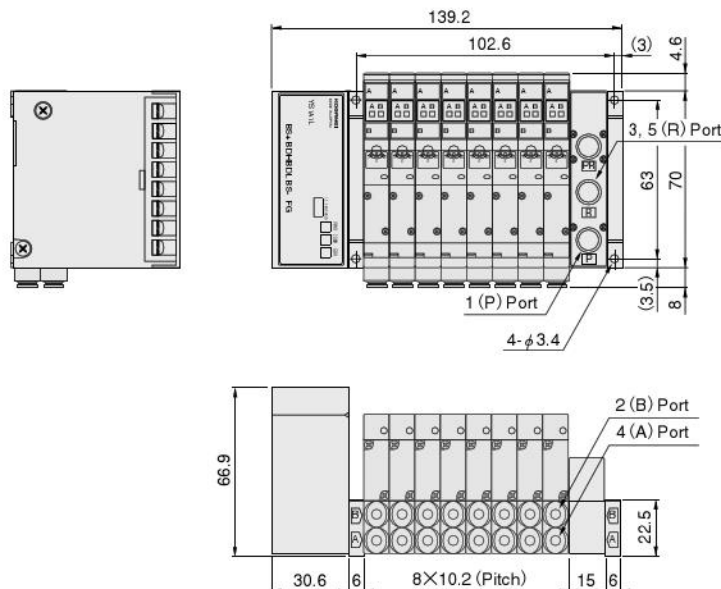

Configuration Example 2

**X80MS1-A1-L**

No.1 ~16 - FMWR090-4E1-J6S DC24V

No.17 - FMPR-PR01S

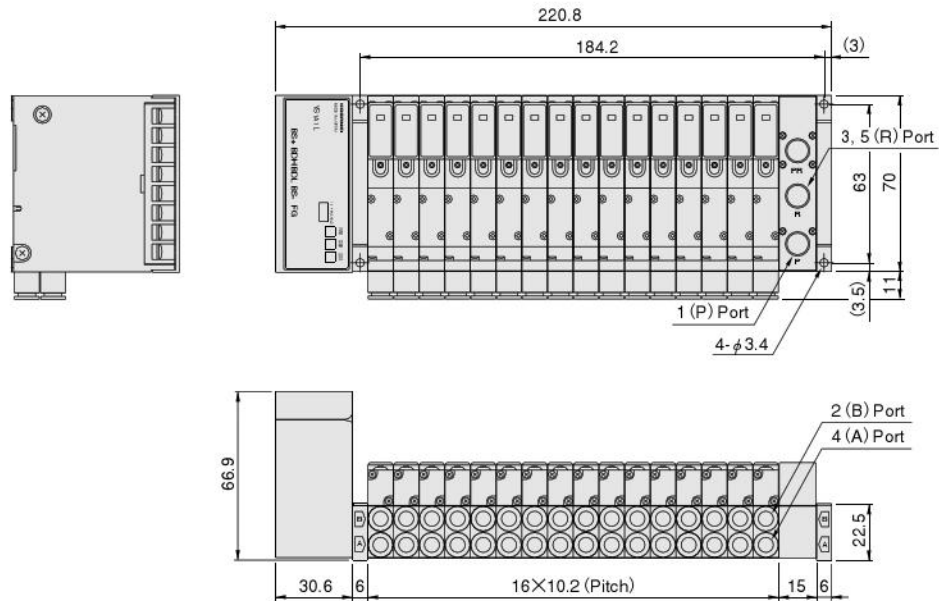

FM-SOLID MANIFOLD X80M SERIES

Configuration Example 3 For CompoBus/D

**X80MS1-91-L-DN**

No.1 - FMCR-F201 DC24V

No.2 ~17 - FMWR090-4E1-J6S DC24V

No.18 - FMPR-PR01S

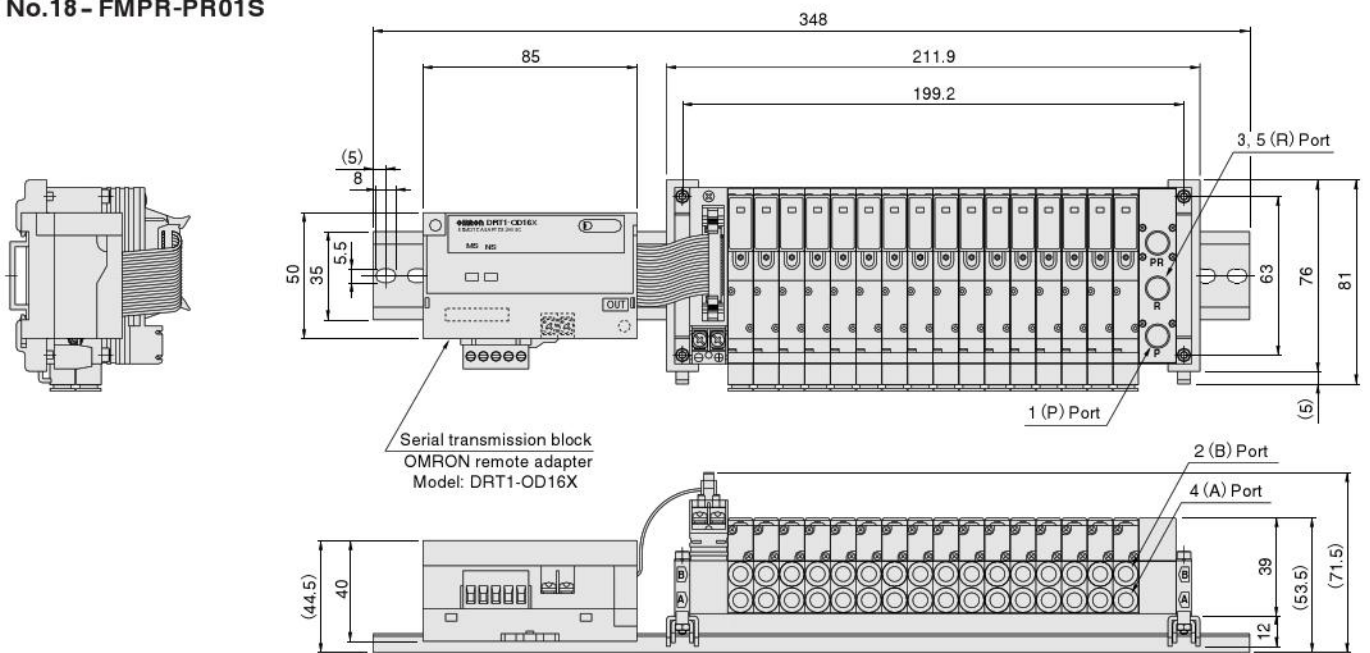

# Compact Serial Transmission System Specifications

## General Specifications

Voltage	DC24V ±10%
Operating temperature range	5~50°C [41~122°F]
Vibration resistance	49.0m/s <sup>2</sup> {5.0G} (Conforms to JIS C 0911)
Shock resistance	98.1m/s <sup>2</sup> {10.0G} (Conforms to JIS C0912)

● For details of specifications, see the user's manuals (see below).

## Compact Serial Transmission Block, Terminal Block (LED) Names

### ● For UNI-WIRE® System

Transmission block specification: -01 (16 outputs), -02 (8 outputs)

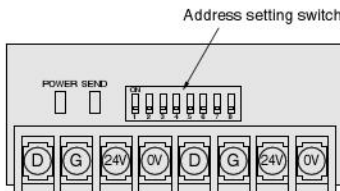

#### LED indicator

Indicator	Description
POWER	<ul style="list-style-type: none"> <li>Lights up when power is turned on</li> <li>Flashes during voltage drops or when over current (a short circuit)</li> </ul>
SEND	<ul style="list-style-type: none"> <li>Flashes during normal transmission</li> <li>Lights up or shuts off during faulty transmission</li> </ul>

#### Remarks

※ The UNI-WIRE® System is a serial parallel transmission system developed jointly by NKE and KURODA PRECISION INDUSTRIES. For details of the UNI-WIRE System, see the NKE or KURODA PRECISION INDUSTRIES catalog, user's manual, etc.

- Number of outputs per block  
16 solenoids (transmission block specification: -01)  
8 solenoids (transmission block specification: -02)
- Related materials: User's manual, document No. HV005

### ● For OMRON B7A Link Terminal

Transmission block specification: -31 (standard type), -32 (high speed type)

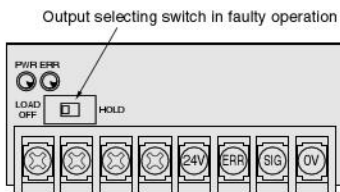

#### LED indicator

Indicator	Description
PWR	Lights up when power is turned on
ERR	Lights up during faulty transmission

#### Remarks

● Connection method: 1 to 1

(Transmission block spec.)	Standard type (-31)	High speed type (-32)
Transmission delay time	Max.31ms	Max.5ms
Transmission distance	Max.500m	Max.100m

※ For details of the B7A Link Terminal, see the OMRON catalog, user's manual, etc.

- Number of outputs per block  
Maximum of 16 solenoids
- Error output specifications  
Output mode: NPN open collector  
Rated load voltage: DC24V  
Output current: Sink current MAX. 40mA
- Related materials: User's manual, document No. HV008

### ● For Mitsubishi Electric MELSECNET/mini-S3

Transmission block specification: -11

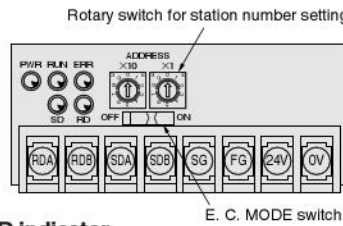

#### LED indicator

Indicator	Description
PWR	Lights up when power is turned on
RUN	Lights up for normal data communication with master station
SD	Flashes during sending data
RD	Flashes during receiving data
ERR	Lights up when data receiving error occurs, shuts off for normal communication

#### Remarks

- Master station: MELSEC-A series  
AJ71PT32-S3, AJ71T32-S3, A2CCPU/A2CJCPU, A1SJ1PT32-S3, link sub-stations up to a maximum of 64 stations, and link I/O numbers up to a maximum of 512.
- ※ For details, see the Mitsubishi Electric's sequencer MELSEC-A series catalog, user's manual, etc.
- Number of outputs per block  
Maximum of 16 solenoids
- ※ Since the block is equivalent to 2 stations, if sub-stations are entirely composed of the blocks, the maximum becomes 32 units.
- Related materials: User's manual, document No. HV006

### ● For KOYO ELECTRONICS INDUSTRIES SA Bus

Transmission block specification: -41 (16 outputs), -42 (8 outputs)

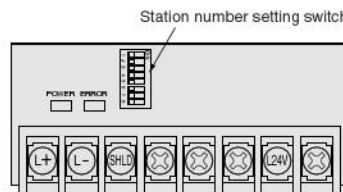

#### LED indicator

Indicator	Description
Power	Lights up when power is turned on
Error	Lights up during faulty transmission or other faults

#### Remarks

- ※ For details of the SA Bus system, see the KOYO ELECTRONICS INDUSTRIES catalog, user's manual, etc.
- Number of outputs per block  
16 solenoids (transmission block specification: -41)  
8 solenoids (transmission block specification: -42)
- Related materials: User's manual, document No. HV009

### ● For OMRON SYSBUS Wire System

Transmission block specification: -21

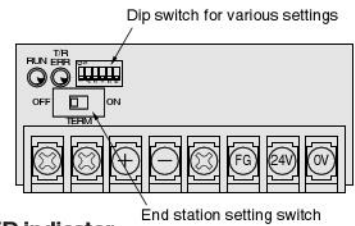

#### LED indicator

Indicator	Description
RUN	Lights up when transmission is normal, and the PC is in operations mode or monitor mode
T/R ERR	<ul style="list-style-type: none"> <li>Flashes during normal transmission</li> <li>Lights up during standby or faulty transmission</li> <li>Shuts off during faults (during watchdog timer fault)</li> </ul>

#### Remarks

- Master station unit: SYSMAC-C (CV) series  
C200H-RM201, C500-RM201
- ※ For details, see the OMRON's programmable controller SYSMAC C(CV) series catalog, user's manual, etc.
- Number of outputs per block  
Maximum of 16 solenoids
- Related materials: User's manual, document No. HV007

### ● For SUNX S-LINK

Transmission block specification: -51 (16 outputs), -52 (8 outputs)

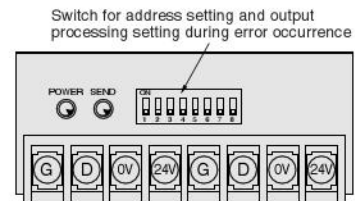

#### LED indicator

Indicator	Description
POWER	Lights up when power is turned on
SEND	<ul style="list-style-type: none"> <li>Flashes during normal transmission</li> <li>Lights up or shuts off during faulty transmission</li> </ul>

#### Remarks

- ※ For details of the S-LINK System, see the SUNX catalog, user's manual, etc.
- Number of outputs per block  
16 solenoids (transmission block specification: -51)  
8 solenoids (transmission block specification: -52)
- Related materials: User's manual, document No. HV010

● For Mitsubishi Electric MELSEC I/O LINK  
Transmission block specification: -61

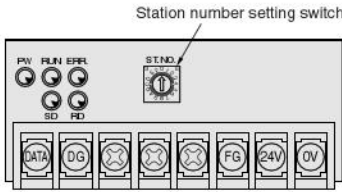

**LED indicator**

Indicator	Description
PW	•Lights up when power is turned on
RUN	•Lights up when receiving data transmitted from master unit is normal
SD	•Lights up during sending data to master unit
RD	•Lights up during receiving data from master unit
ERR.	•Lights up when faulty data transmitted from master unit

**Remarks**

- 16 remote I/O unit connection stations, for a maximum of 128 inputs/outputs
- ※ For details, see Mitsubishi Electric's sequencer catalog, user's manual, etc.
- Number of outputs per block  
Maximum of 16 solenoids
- ※ Since the block is equivalent to 4 stations, if substations are entirely composed of the blocks, a maximum of 4 units can be connected to 1 master unit.
- Related materials: User's manual, document No. HV011

● For OMRON CompoBus/D  
Transmission block specification: -91

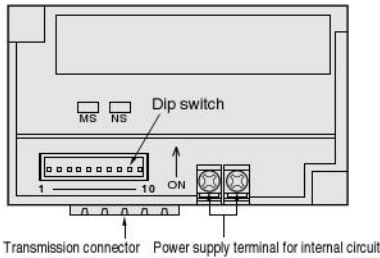

**LED indicator**

Indicator	State	Color	Description
MS	Lights up	Green	•Normal state
	Flashing		•No setting state
	Lights up	Red	•Serious breakdown
	Flashing		•Minor breakdown
	Shuts off	—	•No power supply
NS	Lights up	Green	•Communication connection completed
	Flashing		•No communication connection
	Lights up	Red	•Serious communication fault
	Flashing		•Minor communication fault
	Shuts off	—	•No power supply

**Remarks**

- ※ For details of the CompoBus/D, see the OMRON catalog, user's manual, etc.
- The transmission block is OMRON's remote adaptor-type **DRT1-OD16X**. For details about handling, see OMRON's user's manual.
- Number of outputs per block  
Maximum of 16 solenoids
- Related materials: User's manual, document No. HV014

● For Fuji Electric FA Components & Systems T Link Mini  
Transmission block specification: -71

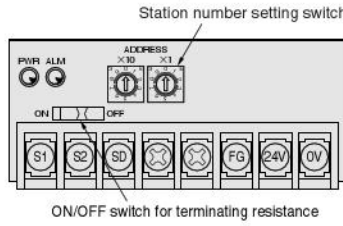

**LED indicator**

Indicator	Description
PWR	•Lights up when power is turned on
ALM	•Lights up during faulty transmission

**Remarks**

- ※ For details of the T Link Mini, see the Fuji Electric FA Components & Systems catalog, user's manual, etc.
- Number of outputs per block  
Maximum of 16 solenoids
- Related materials: User's manual, document No. HV012

● For OMRON CompoBus/S  
Transmission block specification: -A1 (16 outputs), -A2 (8 outputs)

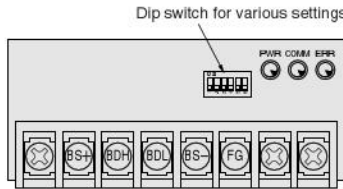

**LED indicator**

Indicator	State	Color	Description
PWR	Lights up	Green	•During power supply
	Shuts off		•Power not supplied
COMM	Lights up	Yellow	•During normal communication
	Shuts off		•Communication fault, or standby
ERR	Lights up	Red	•Communication fault occurred
	Shuts off		•During normal communication, or standby

**Remarks**

- ※ For details of the CompoBus/S, see the OMRON catalog, user's manual, etc.
- Number of outputs per block  
16 solenoids (transmission block specification: -A1)  
8 solenoids (transmission block specification: -A2)
- Related materials: User's manual, document No. HV015

● For KEYENCE KZ-R  
Transmission block specification: -81

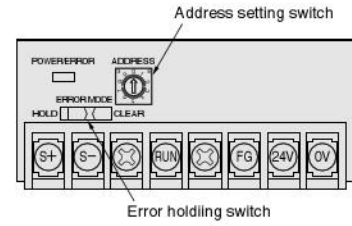

**LED indicator**

Indicator	Description
POWER/ ERROR	•Green: Lights up for normal communications state
	•Orange: Lights up when communications state is poor (can also light up when address settings are incorrect)
	•Red: Lights up during faulty operation, or when transmission is cut off

**Remarks**

- ※ For details of the KZ-R, see the KEYENCE catalog, user's manual, etc.
- Number of outputs per block  
Maximum of 16 solenoids
- Related materials: User's manual, document No. HV013

● For Mitsubishi Electric CC-Link  
Transmission block specification: -B1

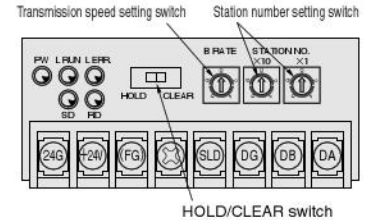

**LED indicator**

Indicator	Description
PW	•Lights up when power is turned on
L RUN	•Lights up when normal data is received from master station
SD	•Lights up during sending data
RD	•Lights up during receiving data
L ERR.	•Lights up during transmission errors, and shuts off when time is over Lights up during station number setting error or transmission speed setting error

**Remarks**

- ※ For details of the CC-Link, see the Mitsubishi Electric catalog, user's manual, etc.
- Number of outputs per block  
16 solenoids (transmission block specification: -B1)
- ※ Since the block occupies 1 station, if remote I/O stations are entirely composed of the blocks, a maximum of 64 units can be connected to 1 master station.
- Related materials: User's manual, document No. HV016

■ For about specifications and handling details, see the above-listed user's manuals (document Nos. HV005~HV016).

# FM-SOLID MANIFOLD X80M SERIES

## Piping Modules

### Features

Selectable according to piping requirements, for reducing of piping work, and easier maintenance.

### Built-in quick fitting type

The 1(P) port offers 2 types (straight and elbow types) of built-in quick fittings for the  $\phi$  8 tube. The 3, 5(R) port is equipped with a built-in muffler.

### 1(P) port female thread type

The 1(P) port has an Rc1/8 female thread.

The 3, 5(R) port has a built-in muffler.

### All port female thread type

The 1(P) port has an Rc1/8 female thread.

The 3, 5(R) port and PR port have captured exhausts.



FMPR-FJ8L



FMPR-FJ8S



FMPR-PR01S



FMPR-FR01

## Piping Module Specifications

Model	1(P) port specification	3, 5(R) port specification
<b>FMPR-FJ8S</b>	With straight quick fitting for $\phi$ 8 tube	With built-in muffler (exhausts to atmosphere)
<b>FMPR-FJ8L</b>	With elbow quick fitting for $\phi$ 8 tube	
<b>FMPR-FR01</b>	Rc1/8 (female thread specification)	Rc1/8 (female thread specification, 3, 5(R) and PR (captured exhausts))
<b>FMPR-PR01S</b>	Rc1/8 (female thread specification)	

## Module Mass

g [oz.]

Model	Mass
<b>FMPR-FJ8S</b>	36 [1.27]
<b>FMPR-FJ8L</b>	42 [1.48]
<b>FMPR-FR01</b>	37 [1.31]
<b>FMPR-PR01S</b>	50 [1.76]

# FMPR Dimensions of Piping Module (mm)

※Height with end block attached is +1mm [0.039in.] longer than indicated below.

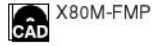

## Built-in straight quick fitting type FMPR-FJ8S

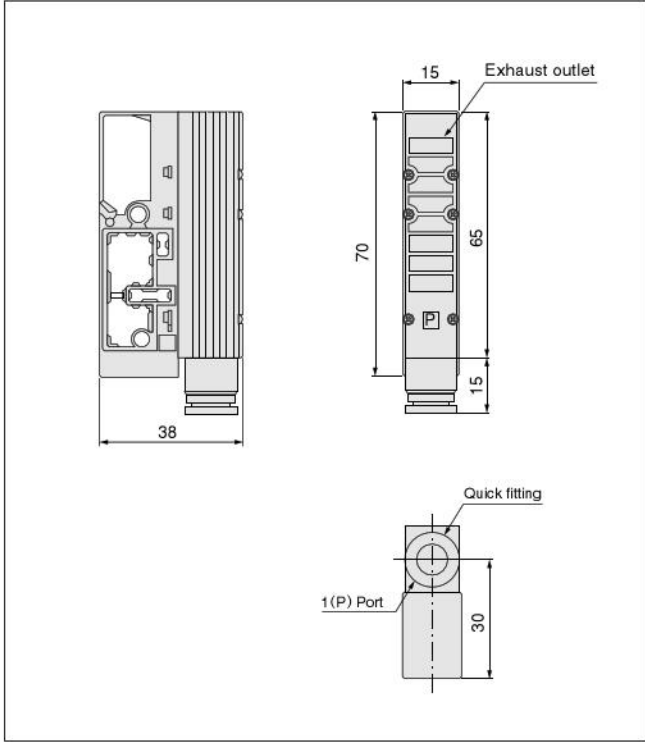

## Built-in elbow quick fitting type FMPR-FJ8L

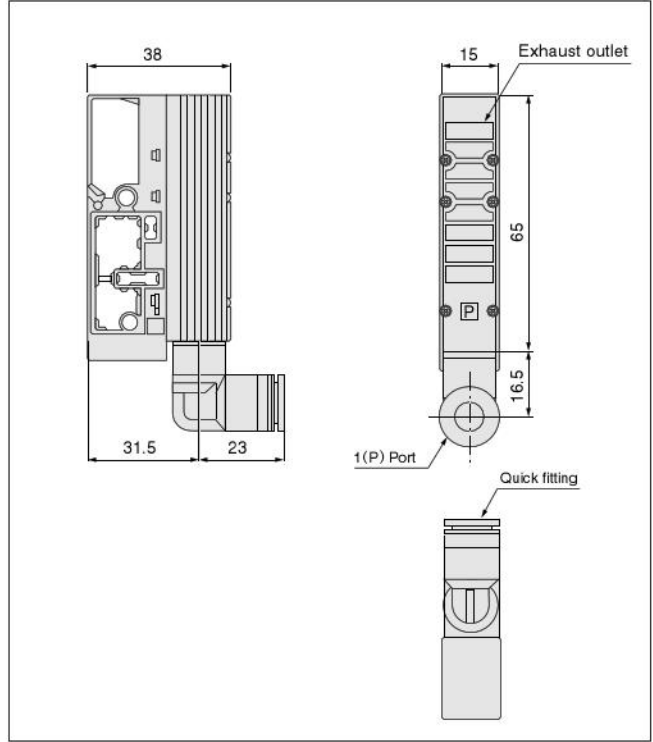

## 1(P) port female thread type FMPR-FR01

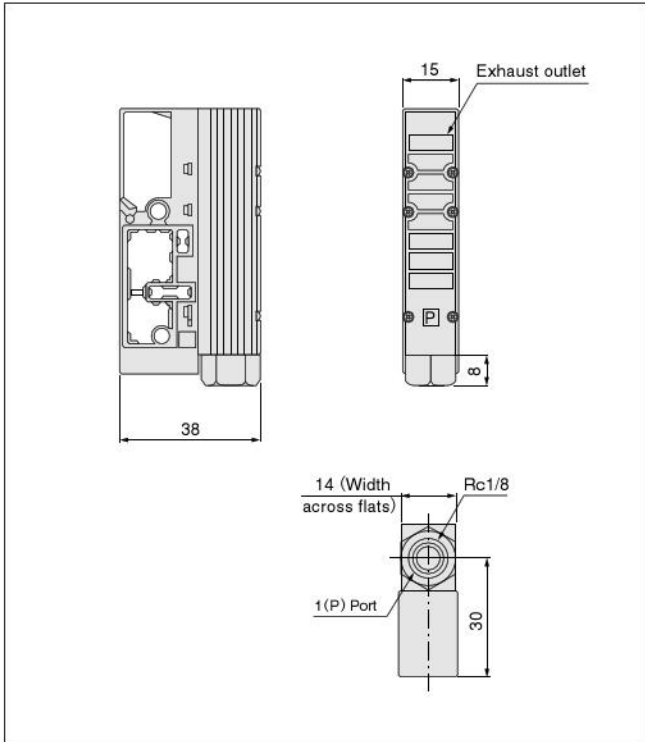

## All port female thread type FMPR-PR01S

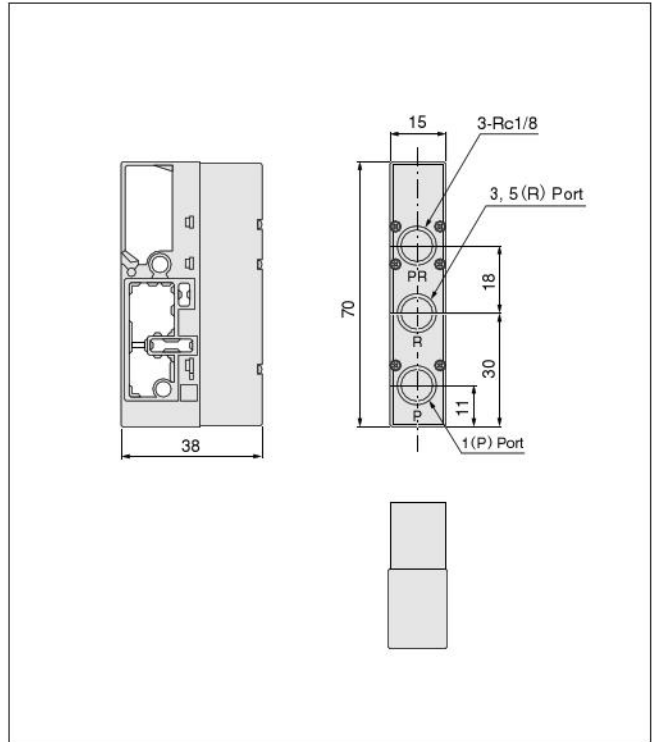

FM-SOLID MANIFOLD X80M SERIES

# FM-SOLID MANIFOLD X80M SERIES

## Valve Modules

### Features

Mounts the compact, low power consumption 090 series solenoid valves, and offers modularized compact, large-capacity valves, as well as tandem solenoid valves that have 2 solenoids in 1 unit in the space for 1 module, to enable the achievement of a highly efficient, optimum system design.

- Offers powerful control up to  $\phi 40$  cylinders.
- Effective area 3.5mm<sup>2</sup> / (Cv 0.2) / Power consumption 0.5W.
- Base piping type
- 4(A), 2(B) ports on the module base offer a range of 4 types of quick fittings, straight and elbow types for both  $\phi 4$  and  $\phi 6$  tubes, and an M5 female thread type.
- The tandem solenoid uses a locking type manual override that allows the operation of a single manual override for 2 solenoids.



FMWR090E1

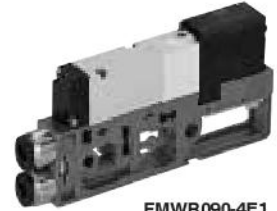

FMWR090-4E1



FMWR090-4KE2

### Valve Module Specifications

#### Basic Models and Valve Functions

Solenoid valves 090 series base piping type	FMWR090E1	FMWR090-4E1	FMWR090-4KE2	FMWR090-4ME2	FMWR093-4ME2
Number of positions	2 positions			3 positions	
Number of ports	2, 3 ports	5 ports			
Valve function	Normally closed (NC) or Normally open (NO), optional	Single solenoid	Twin solenoid	Tandem solenoid	Closed center (standard), exhaust center (optional) or pressure center (optional)

Remark: For optional specifications and order codes, see p.392.

#### Module Mass

g [oz.]

Model	Mass				
	-J4S	-J4LS	-J6S	-J4U	-M5M
FMWR090E1	42 [1.48]	45.5 [1.60]	48 [1.69]	42 [1.48]	42 [1.48]
FMWR090-4E1	42 [1.48]	45.5 [1.60]	48 [1.69]	42 [1.48]	42 [1.48]
FMWR090-4KE2	84 [2.96]	91 [3.21]	96 [3.39]	84 [2.96]	84 [2.96]
FMWR090-4ME2	62 [2.19]	65.5 [2.31]	68 [2.40]	62 [2.19]	62 [2.19]
FMWR093-4ME2	67 [2.36]	70.5 [2.49]	73 [2.57]	—	67 [2.36]

### Specifications

Solenoid valve		090 series				
Basic model		Base piping type				
Item		FMWR090E1	FMWR090-4E1	FMWR090-4KE2	FMWR090-4ME2	FMWR093-4ME2
Media		Air				
Operation type		Internal pilot				
Effective area [Cv]	mm <sup>2</sup>	3.5 [0.2]				3.0 [0.17]
Port size		Dedicated to manifold use.				
Lubrication		Not required				
Operating pressure range	MPa {kgf/cm <sup>2</sup> } [psi.]	0.2~0.7 {2.0~7.1} [29~102]				
Proof pressure	MPa {kgf/cm <sup>2</sup> } [psi.]	1.05 [10.7] [152]				
Response time <sup>Note</sup>	ms	DC12V, DC24V	14/20 or below		14	
Maximum operating frequency	Hz	5				
Minimum time to energize for self holding	ms	—			50	
Operating temperature range (atmosphere and media)	°C [°F]	5~50 [41~122]				
Shock resistance	m/s <sup>2</sup> [G]	1373.0 [140.0] (Axial direction 245.2 [25.0])				
Mounting direction		Any				

Note: Values when air pressure is 0.5MPa {5.1 kgf/cm<sup>2</sup>} [73psi.]. The value for 090-4KE2, 090-4ME2 is when switching from the opposite position, and for 093-4ME2 is for the closed center valve, when switching from the neutral position.

### Solenoid Specifications

Rated voltage		DC12V		DC24V	
Item					
Type		With LED indicator (with diode for surge suppression <sup>Note</sup> )			
Operating voltage range ( $\pm 10\%$ )	V	10.8~13.2		21.6~26.4	
Current (when rated voltage is applied)	mA	40		20	
Power consumption	W	0.5 (with LED indicator)			

Note: Diode for surge suppression is built into the base.

# Cylinder Operating Speed

## Cylinder operating speed

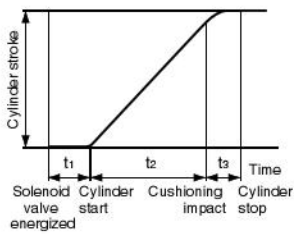

To obtain the time required for the cylinder to complete 1 stroke, add cylinder's delay time  $t_1$  (time between energizing of the solenoid valve and actual starting of the cylinder), to the cylinder's max. speed operating time  $t_2$ . When a cushion is used, add the cushioning time  $t_3$ , to the above calculation. The standard cushioning time  $t_3$  is approximately 0.2 seconds.

### FMWR090-4E1 FMWR090-4ME2

#### Measurement conditions

- Air pressure: 0.5MPa [5.1kgf/cm<sup>2</sup>] [73psi.]
- Piping inner diameter and length:  $\phi 4 \times 1000$ mm [39in.]
- Fitting:  $\phi 6$  straight quick fitting (-J6S)
- Load ratio =  $\frac{\text{Load}}{\text{Cylinder theoretical thrust}}$  (%)
- Cylinder stroke: 150mm [5.91in.] for  $\phi 20 \sim \phi 40$

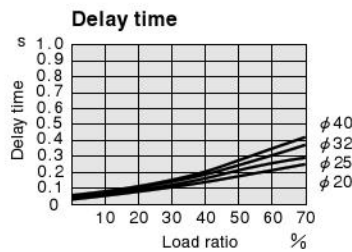
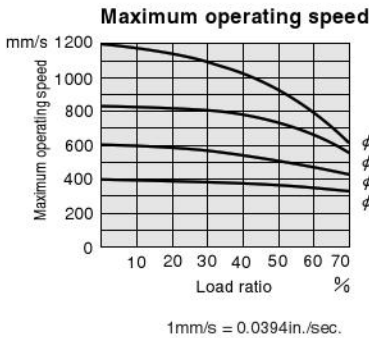
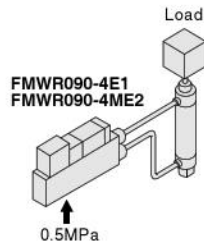

## Flow Rate

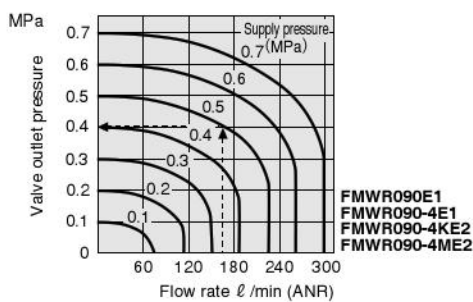

### How to read the graph

When the supply pressure is 0.5MPa [73psi.] and flow rate is 170  $l/min$  [6.0ft<sup>3</sup>/min.] (ANR), the valve outlet pressure becomes 0.4MPa [58psi.].

# FMWR Dimensions of Base Piping Type Valve Module (mm)

※Height with end block attached is +1mm  
[0.039in.] longer than indicated below.

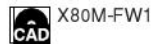

## 2-, 3-port

### FMWR090E1

- With quick fittings: **-J4S, -J4LS** (built-in straight quick fittings for  $\phi$  4 tube)  
**-J6S** (built-in straight quick fittings for  $\phi$  6 tube)

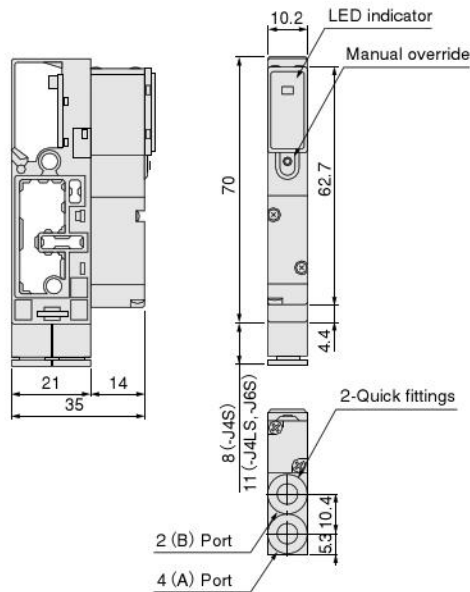

Note: For FMWR090E1, the 2(B) port is plugged, while for FMWR090E1-11, the 4(A) port is plugged ( $\phi$  4: **UP-4**,  $\phi$  6: **UP-6**).

- With elbow quick fittings: **-J4U** (built-in elbow quick fittings for  $\phi$  4 tube)

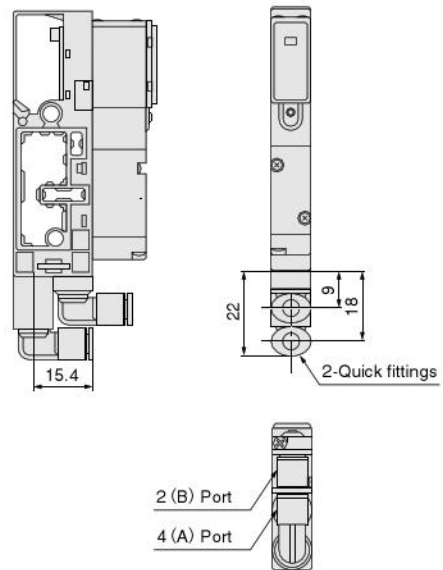

Note: For FMWR090E1, the 2(B) port is plugged, while for FMWR090E1-11, the 4(A) port is plugged ( $\phi$  4: **UP-4**).

- M5 female thread type: **-M5M**

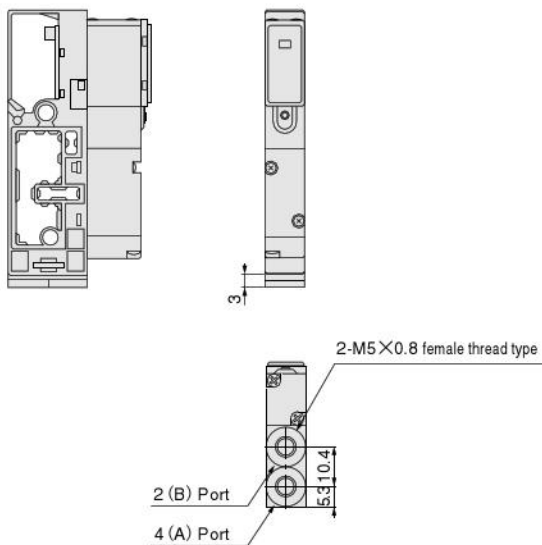

Note: For FMWR090E1, the 2(B) port is plugged, while for FMWR090E1-11, the 4(A) port is plugged (M5: **PF**).

※Height with end block attached is +1mm [0.039in.] longer than indicated below.

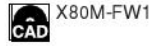

Single solenoid valve

# FMWR090-4E1

- With quick fittings: **-J4S, -J4LS** (built-in straight quick fittings for  $\phi$  4 tube)  
**-J6S** (built-in straight quick fittings for  $\phi$  6 tube)

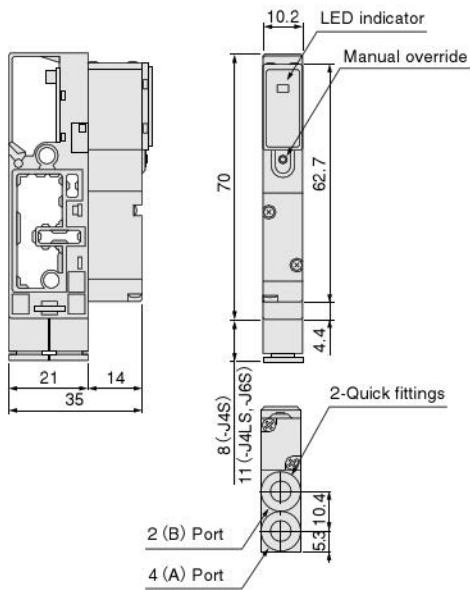

- With elbow quick fittings: **-J4U** (built-in elbow quick fittings for  $\phi$  4 tube)

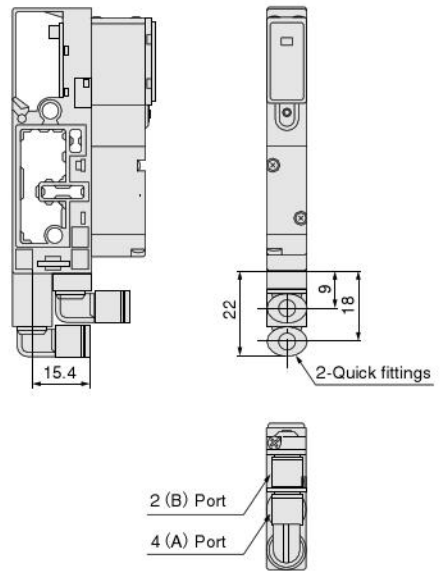

- M5 female thread type: **-M5M**

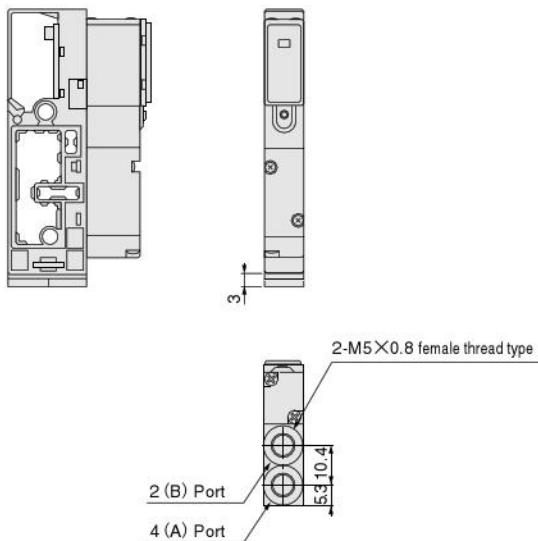

FM-SOLID MANIFOLD X80M SERIES

# FMWR Dimensions of Base Piping Type Valve Module (mm)

※Height with end block attached is +1mm  
[0.039in.] longer than indicated below.

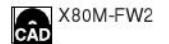

## Twin solenoid valve

### FMWR090-4KE2

- With quick fittings: **-J4S, -J4LS** (built-in straight quick fittings for  $\phi$  4 tube)  
**-J6S** (built-in straight quick fittings for  $\phi$  6 tube)

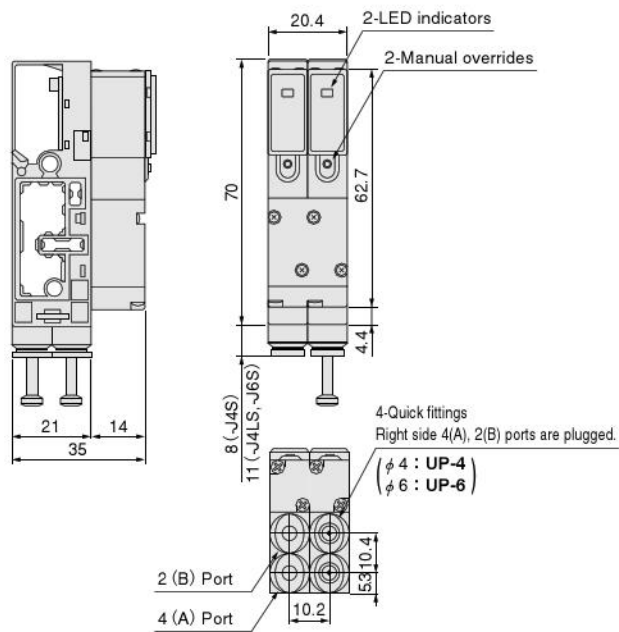

- With elbow quick fittings: **-J4U** (built-in elbow quick fittings for  $\phi$  4 tube)

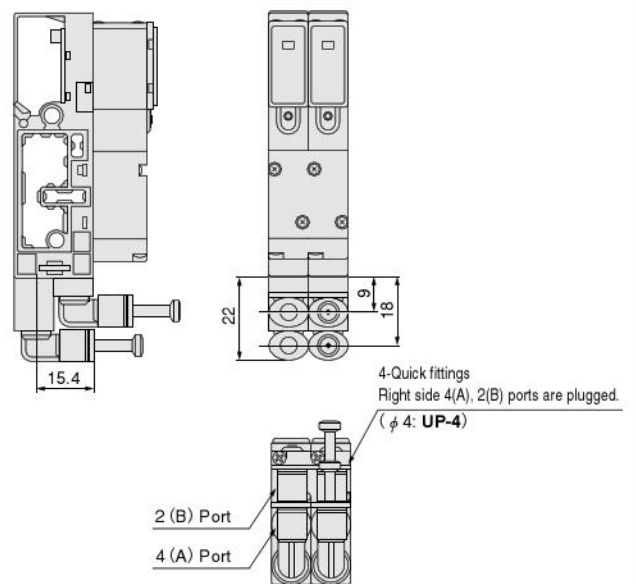

- M5 female thread type: **-M5M**

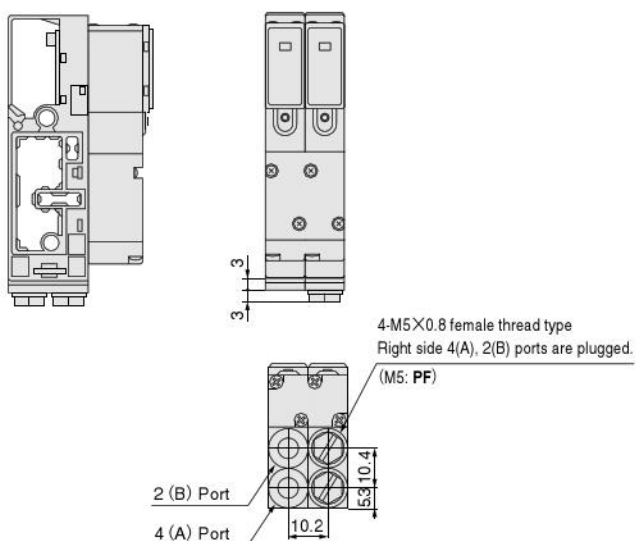

※Height with end block attached is +1mm [0.039in.] longer than indicated below.

Tandem solenoid valve

**FMWR090-4ME2**

- With quick fittings: **-J4S, -J4LS** (built-in straight quick fittings for  $\phi$  4 tube)  
**-J6S** (built-in straight quick fittings for  $\phi$  6 tube)

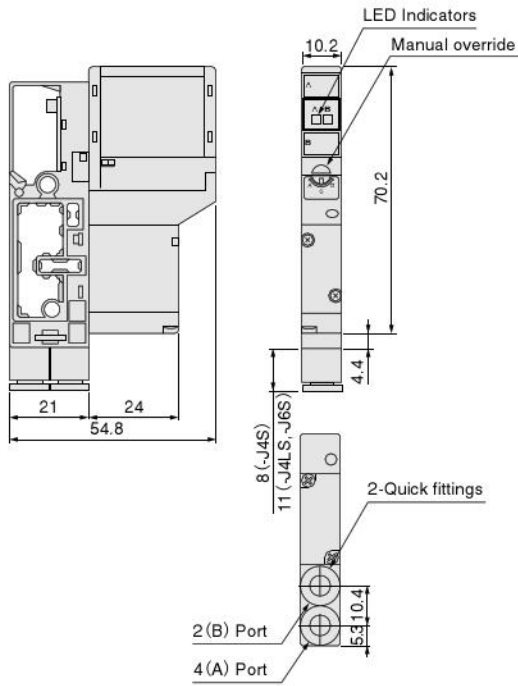

- With elbow quick fittings: **-J4U** (built-in elbow fittings for  $\phi$  4 tube)

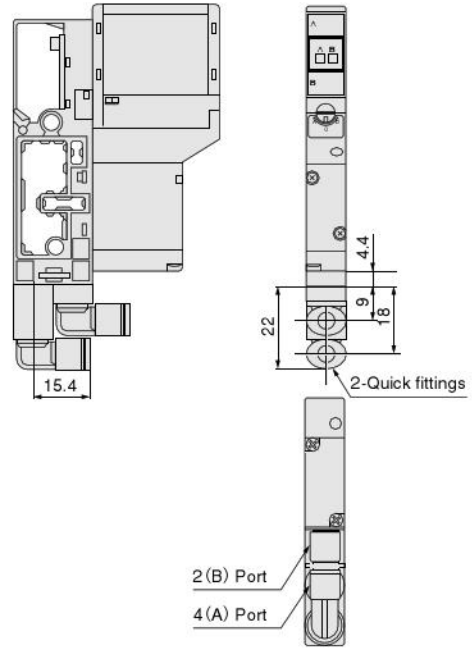

- M5 female thread type: **-M5M**

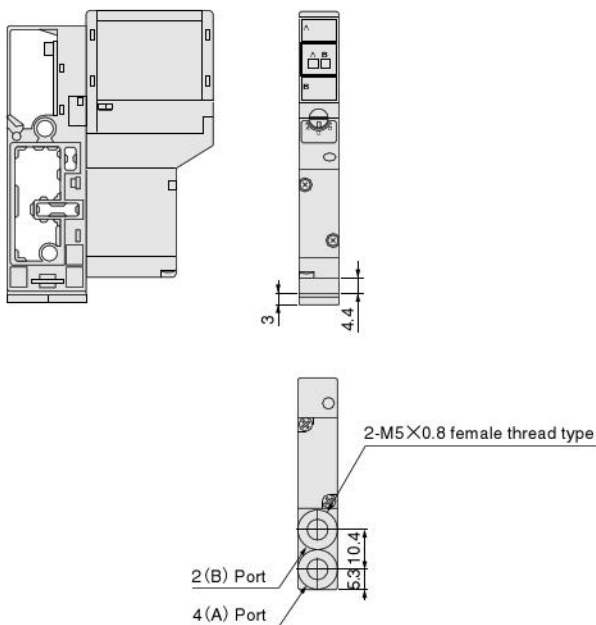

# FMWR Dimensions of Base Piping Type Valve Module (mm)

※Height with end block attached is +1mm  
[0.039in.] longer than indicated below.

## Tandem solenoid valve

### FMWR093-4ME2

- With quick fittings: -J4S, -J4LS (built-in straight quick fittings for  $\phi$  4 tube)  
-J6S (built-in straight quick fittings for  $\phi$  6 tube)

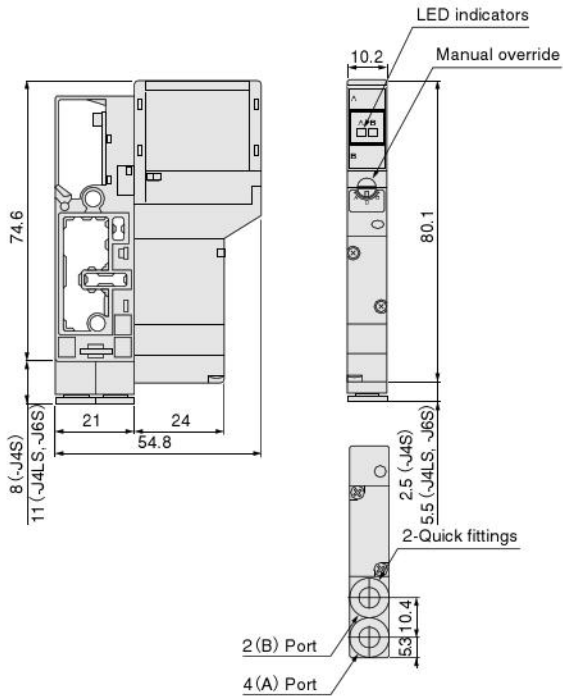

- M5 female thread type: -M5M

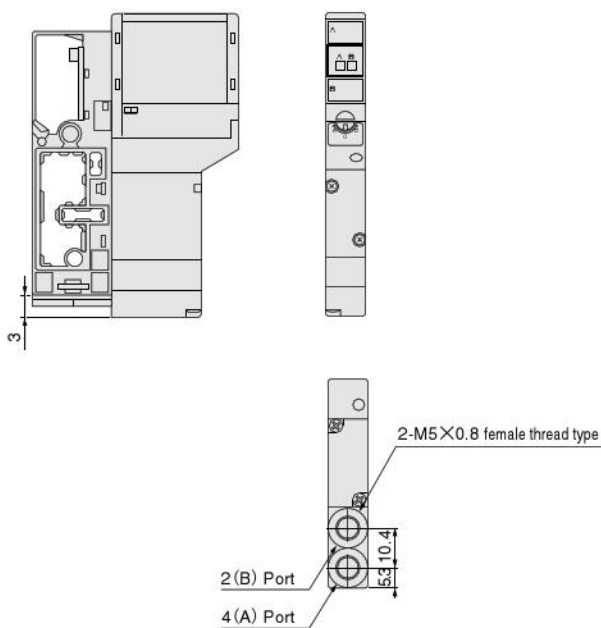

# FM-SOLID MANIFOLD X80M SERIES

## Block-off Plate Module

### Features

Offers an additional valve mounting space, to provide for the future installation of add-on valves.

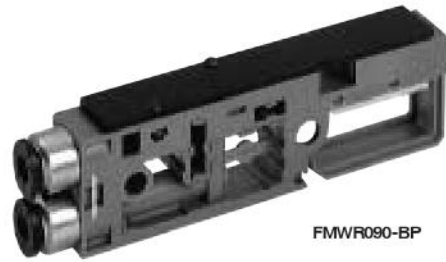

FMWR090-BP

### Block-off Plate Module Specifications

---

#### Module Mass g [oz.]

Model	Mass				
	-J4S	-J4LS	-J6S	-J4U	-M5M
FMWR090-BP	24 [0.85]	27.5 [0.97]	30 [1.06]	24 [0.85]	24 [0.85]

# Dimensions of Block-off Plate Module (mm)

※Height with end block attached is +1mm [0.039in.] longer than indicated below.



## Block-off plate module

### FMWR090-BP

- With  $\phi 4$  straight quick fittings: **-J4S** (built-in straight quick fittings)  
**-J4LS** (built-in long straight quick fittings)

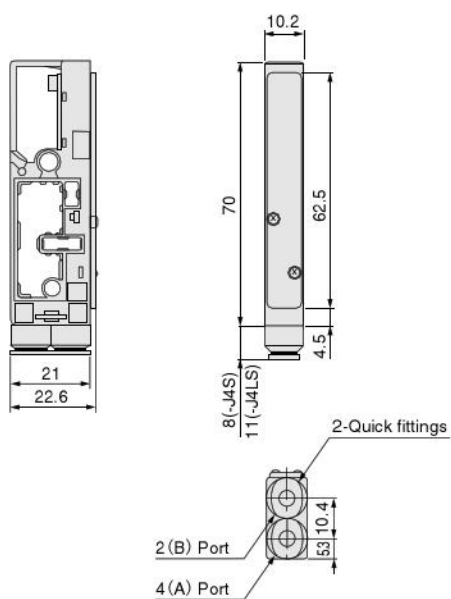

- With  $\phi 6$  straight quick fittings: **-J6S** (built-in straight quick fittings)

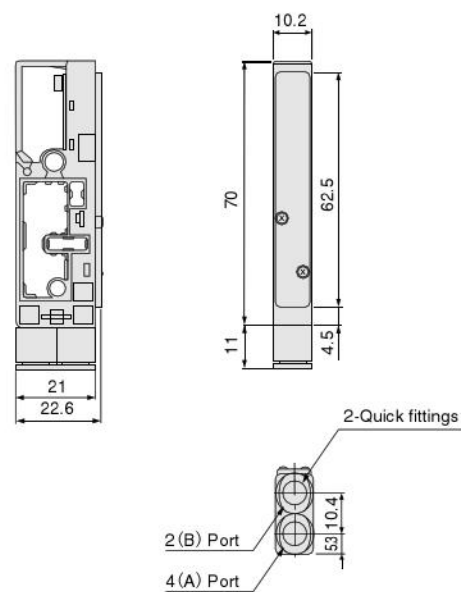

- With  $\phi 4$  elbow quick fittings: **-J4U** (built-in elbow quick fittings)

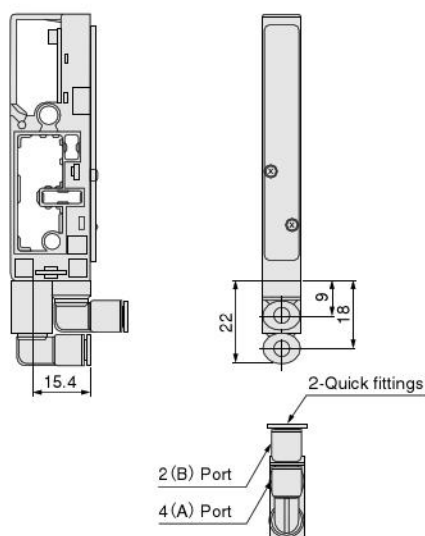

- M5 female thread type: **-M5M**

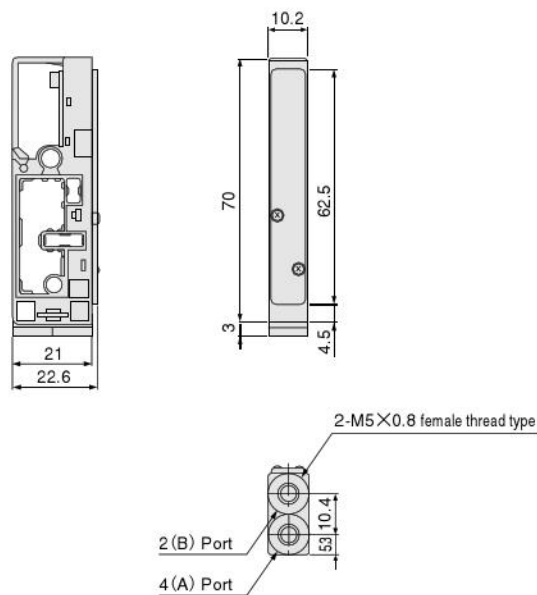

# FM-SOLID MANIFOLD X80M SERIES

## End Blocks

### Features

- End block piping types are also in the product range.
- Seven types offer minimum installation space.
- An end block with DIN rail mounting brackets is also available as an option.

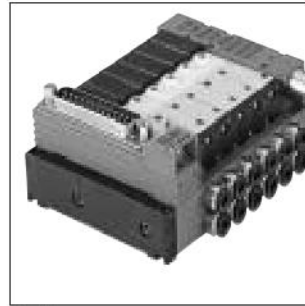

X80M

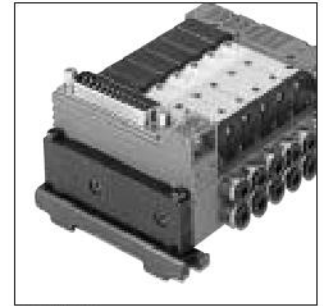

X80M-DN



X80M-ER

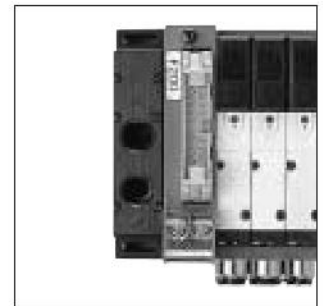

X80M-UL

FM-SOLID MANIFOLD X80M SERIES

### End Block Mass

#### Module Mass

g [oz.]

Model	Mass
X80M	30 [1.06]
X80M-ER	47 [1.66]
X80M-EL	47 [1.66]
X80M-ED	64 [2.26]
X80M-UR	80 [2.82]
X80M-UL	80 [2.82]
X80M-UD	130 [4.59]
X80M-DN	118 [4.16] (88 [3.10]) <sup>Note</sup>

Note: Figures in parentheses ( ) are the mass for the DIN rail mounting bracket only.

## Dimensions of End Block (mm)

CAD X80M-ED

### End block module type

#### X80M (right and left) 1 set

- The drawing shows a left-side end block with the solenoid on the upper side of the case.
- The end blocks on both ends have left-right symmetry in dimensions and mounting hole locations.

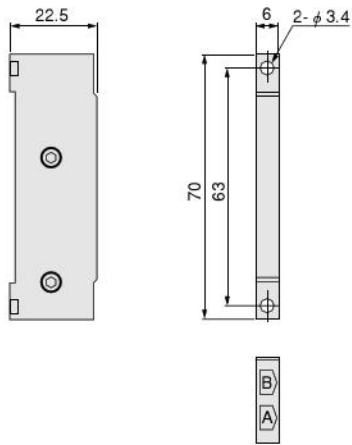

### With DIN rail mounting bracket type

#### X80M-DN (right and left) 1 set

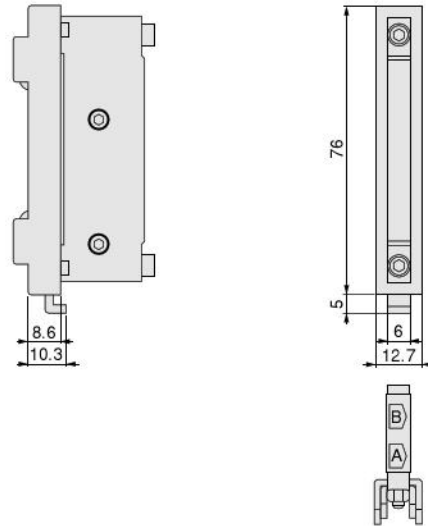

- A DIN rail mounting bracket can be mounted on any end block.

### End block side piping type

#### X80M-ER/-EL/-ED (right and left) 1 set

- The drawing shows a left-side end block with the solenoid on the upper side of the case.
- The end blocks on both ends have left-right symmetry in dimensions and mounting hole locations.

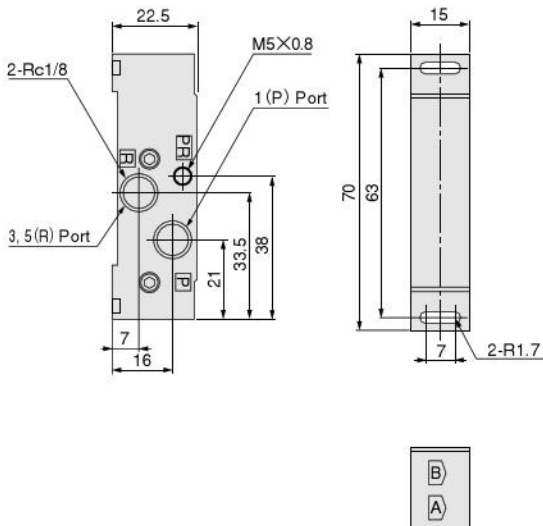

### End block upper piping type

#### X80M-UR/-UL/-UD (right and left) 1 set

- The drawing shows a left-side end block with the solenoid on the upper side of the case.
- The end blocks on both ends have left-right symmetry in dimensions and mounting hole locations.

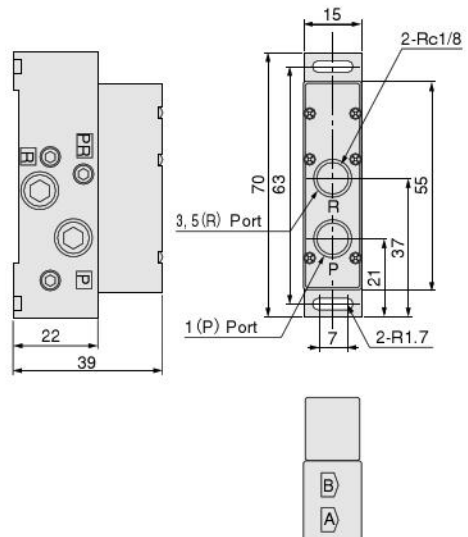

## Dimensions of Various End Block Piping Types (mm)

**X80M-ER**

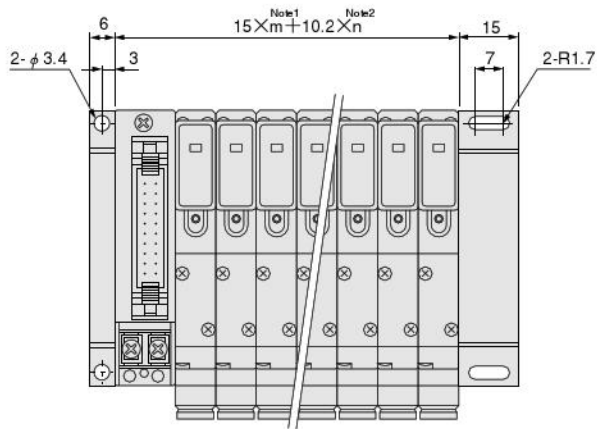

**X80M-UR**

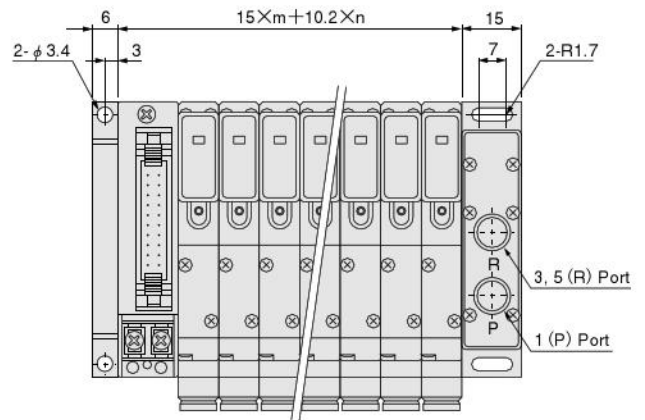

**X80M-EL**

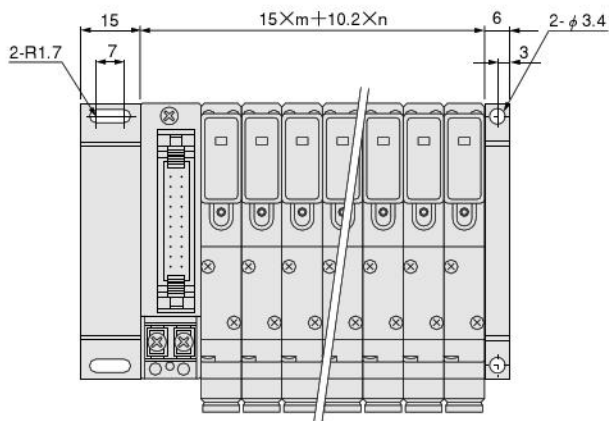

**X80M-UL**

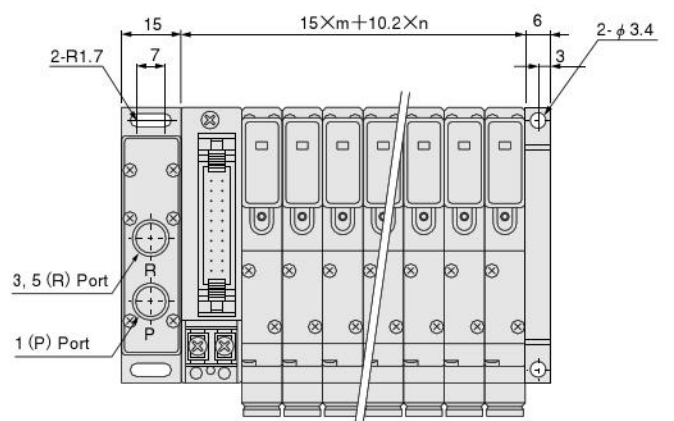

**X80M-ED**

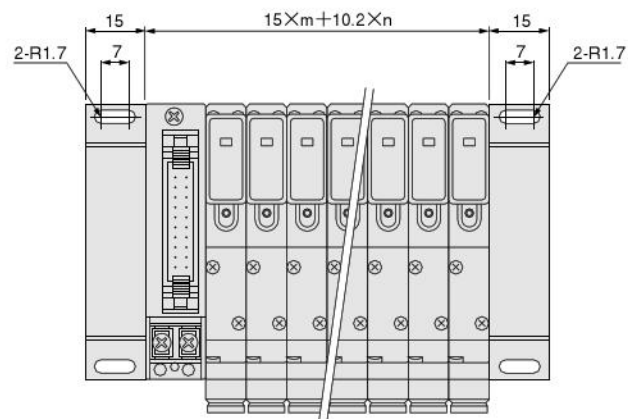

**X80M-UD**

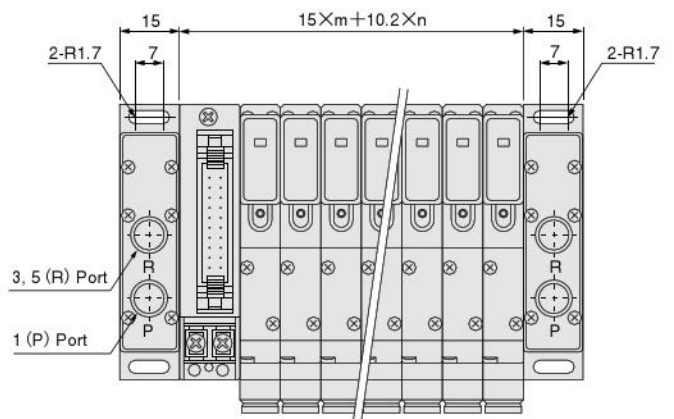

Notes: 1. "m" is the number of wiring modules and piping modules.  
2. "n" is the number of valve modules and block-off plate modules.



## Solenoid for X80M series

### Internal circuit

#### Single solenoid

● DC12V, DC24V

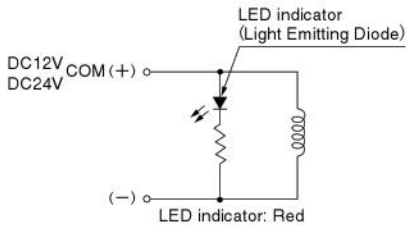

#### Tandem solenoid

● DC12V, DC24V

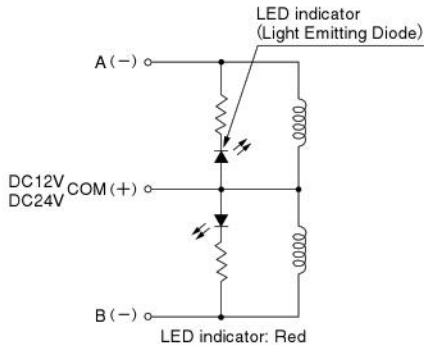

- Cautions:**
1. Do not apply megger between the pins.
  2. The solenoid will not short circuit even if the wrong polarity is applied, but the valve will not operate.
  3. Avoid energizing simultaneously. The valve could enter a neutral position.
  4. Leakage current inside the circuit could result in failure of the solenoid valve to return, or in other erratic operation. Always use it within the range of the allowable leakage current. If circuit conditions, etc. cause the leakage current to exceed the allowable leakage current, consult us.

### Wiring diagram in the base interior for the wiring of tandem solenoid (-D)

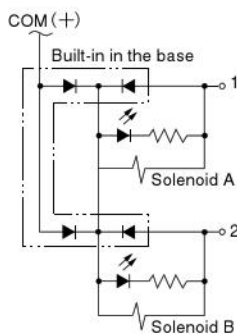

**Caution:** Contact us for COM (-)



## Manual override

### Non-locking type

To operate the manual override, press it all the way down. For the single solenoid, the valve works the same as when in the energized state as long as the manual override is pushed down, and returns to the rest position upon release.

For the twin solenoid, pressing the manual override on the 12(S1) side switches the 12(S1) to enter the energized position, and the unit remains in that position even after the manual override is released. To return it to the normal position, operate the manual override on the 14(S2) side. This is the same for the solenoid 14(S2).

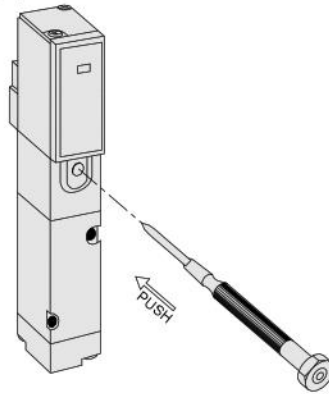

### Locking type

To lock the button, use a small screwdriver to push down on the manual override button all the way and turn it clockwise 45 degrees.

When locked, turning the manual override button 45 degrees in the counterclockwise direction returns it to its normal position, and releases the lock.

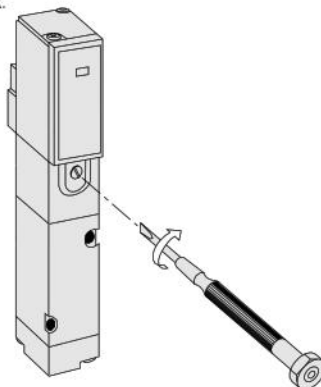

- Cautions:**
1. The 090 series valves are pilot type solenoid valves, the manual override cannot switch the main valve without air supplied from the 1(P) port.
  2. Always release the lock of the locking type manual override before commencing normal operation.
  3. Do not attempt to operate the manual override with a pin or other object having an extremely fine tip. It could damage the manual override button.
  4. Do not turn the manual override more than needed. It could result in defective operation.

# Important Precautions

## Mounting

1. While any mounting direction is allowed, avoid mountings that twist the manifold.
2. When connecting piping to manifolds or other devices, flush the tubes completely by blowing compressed air before piping. If metal chips, sealing tape, or rust generated during piping work enter, it may cause a malfunction such as an air leakage.
3. When mounting a valve unit inside the control panels, or when the operation requires long energizing periods, consider providing heat radiation.
4. The valve module cannot be operated with the 4(A), 2(B) ports open to the atmosphere.

## Atmosphere

Avoid using it in the locations and environment listed below, as it could result in malfunction of the valve.

If use in such conditions is unavoidable, always provide a cover or other adequate protective measures:

- ① Location affected by strong vibration or impact
- ② Location with temperature exceeding the 5~50°C [41~122°F] range
- ③ Location with large change in temperature and dew condensation
- ④ Location exposed to direct sunlight
- ⑤ Location with atmosphere containing organic solvents, phosphate acid ester type hydraulic oil, sulphur dioxide, chlorine gas, or other acids
- ⑥ Location directly exposed to water drops and oil drops
- ⑦ Environment where the valve body is subject to dew condensation
- ⑧ Location where the valve body is directly exposed to metal chips, dust particulate, etc.

## Media

1. Use air for the media. For the use of any other media, consult us.
2. Air used for the cylinder should be clean air that contains no deteriorated compressor oil, etc. Install an air filter (filtration of 40 μm or less) near the valve to remove collected liquid or dust. In addition, drain the air filter periodically.
3. Use the manifold without lubrication as much as possible. When the actuator requires lubrication, use Turbine Oil Class 1 (ISO VG32) or the equivalent. Avoid using spindle oil or machine oil.

## Piping

1. For the 1(P) port piping, use a size that matches the manifold's piping connection port. Insufficient flow rate or pressure could result in defective valve operation or in insufficient actuator output.
2. When installing piping or mufflers to the 3, 5(R) port, ensure minimum exhaust resistance.
3. On rare occasions, exhaust gas can interfere with other valves and actuators. In those situations, either install piping modules at both ends for exhaust, or install a port isolator at an intermediate location to isolate the exhaust air, and separate the exhaust in combination with a piping module.
4. When a multiple number of valves are operated simultaneously on a multi-station manifold, or in high-frequency applications, install piping modules on both ends, and supply air from the 1(P) port and exhaust it from the 3, 5(R) port. (For details, see the piping module page.)

## Wiring

1. Confirm positive common or negative common.
2. Firmly insert connectors and tighten screws.
3. Confirm the polarity of the power supply and pin locations, and connect correctly. (For details, see the wiring module page.)

## Valve module

When mounting the solenoid valves 090 series, the solenoid is a plug-in type and valve modules are already connected to the wiring modules by wiring, so there is no need for wiring at each station.

◆**Precautions for use of the twin solenoid valve**  
When using the base piping type twin solenoid valve (FMWR090-4KE2), use with plugs inserted in the 4(A) and 2(B) ports (quick fittings) on the right side ports (see the illustration below). Note that the twin solenoid valve occupies 2 stations of the single solenoid valve base, which means that valve replacement on the base is possible.

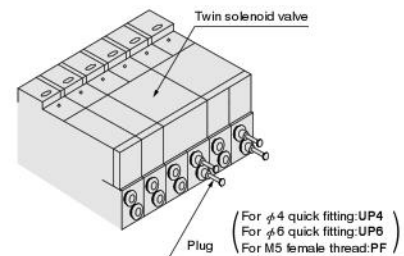

## Piping module

Piping modules are divided into 2 types, a port type and a built-in muffler type. In addition, the use of air supply and exhaust, and using multiple units, make the module also be used as a piping branch.

◆**Piping in an embedded port**  
When the air supply port in the built-in muffler type has a female thread specification (FMPP-FR01), use a wrench on the port's hexagonal portion to secure it in place while piping.

◆**Precautions**  
While air supply and exhaust for the valve module are performed by using this piping module, the number of valves in use could lead to air supply pressure and flow rate shortages, resulting in defective valve operation or in insufficient actuator output. See the table below when determining the required number of piping modules.

Model	Number of valves
Solenoid valves 090 series	6

※Number of valves does not refer to the valves that could be mounted on a single manifold. It is the number of valves that enables the supply of air simultaneously to a secondary side by using a single piping module.

(Example) When ten 090 series solenoid valves are mounted on a single manifold, and 8 of those valves are in simultaneous operation, use 2 piping modules.

(Example) When ten 090 series solenoid valves are mounted on a single manifold, and 3 of those valves are in simultaneous operation, use 1 piping module.

# Important Precautions

## Port isolator

The following 3 types of port isolators are available:

- ① Block of supply air (Model: **FMBR-P**)
- ② Block of exhaust air (Model: **FMBR-R**)
- ③ Block of supply and exhaust air (Model: **FMBR-A**)

### ◆Precautions

- (1) Confirm a marking label on the bottom of the manifold for port isolator locations. (Because the port isolators are assembled inside the manifold base, the outward appearance and dimensions do not change.)
- (2) While a port isolator can be installed in any location required on each module, its position cannot be changed after shipping.
- (3) The port isolator is located on the left side of the designated module (solenoid on top). Therefore, it blocks the air for that portion (see the diagram).

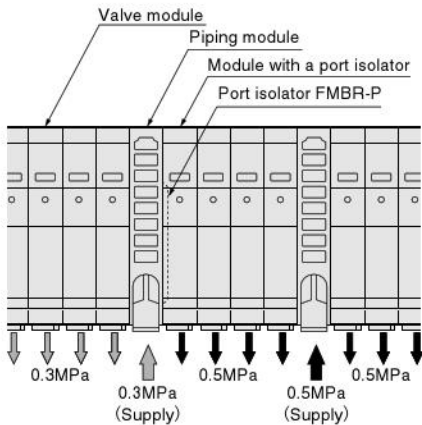

## Example of system configuration

When the controller is negative common, the manifold side should be positive common. And when the controller is positive common, the manifold side should be negative common. In this system configuration example, the controller side is always negative common type (and the manifold side is positive common type).

### ■When the output unit requires no power supply.

<A system that uses a cable to transmit control voltage only>

- The power supply connection terminal (Fcc, D-sub connector type) uses positive polarity wiring only, with the negative polarity left open as a dead terminal.
- Since the terminal block type's common is a positive polarity, use it as shown for wiring:

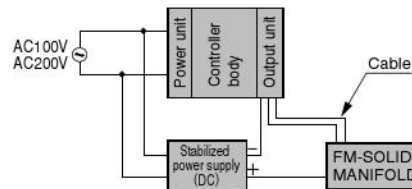

### ■When the output unit requires a power supply.

#### Method ①

- Connect positive and negative power supply wires to the power supply connection terminal, and supply power to the output unit through the connection cable's positive and negative lines.
- Can be shared with the same cable as the control voltage.

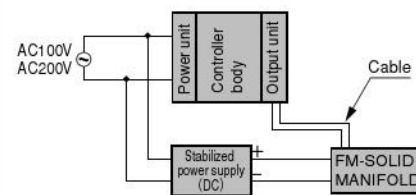

Note: The terminal block type uses the method shown below.

#### Method ②

- Supply power to the output unit, and connect the positive line to the manifold side.
- Leave the negative polarity as a dead terminal.
- For the terminal block type, connect the positive line to the common.

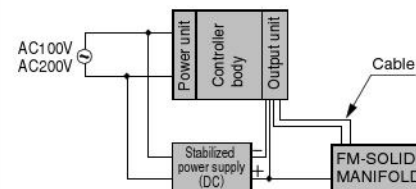

## How to use the power supply connection terminal

Power supply terminal blocks (power supply connection terminals) are provided for the -FMCR, -F101, -F200, -F201, and -D250 units. In output units where power supply from the output is required for the internal circuits (see the diagram), power lines can be connected to the same cable, in the same way as load (solenoid) lines.

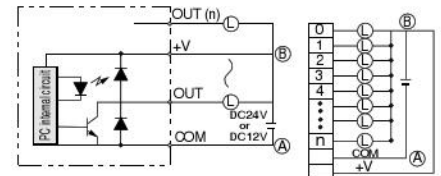

### ■Connection diagram between PC and manifold (connector)

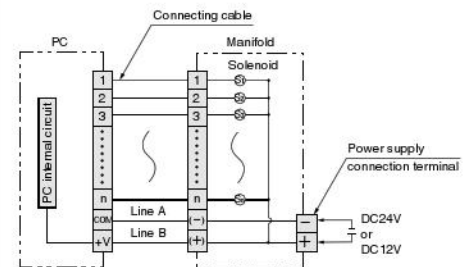

Line A : COM (0V or negative) line

Line B : +V line

	FMCR-F101	FMCR-F200	FMCR-F201	FMCR-D250 FMCR-G250
(-)	9	17, 18	9, 19	20, 21, 22
(+)	10	19, 20	10, 20	23, 24, 25

### Mounting onto a DIN rail

When mounting the manifold onto a DIN rail, follow the procedure shown below:  
 Applicable DIN rail: Equivalent to DIN standard (EN50022)

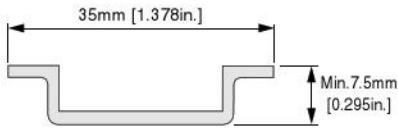

#### Mounting procedure

The DIN rail mounting bracket is composed of an upper and lower two-part construction.

- ① Loosen the end block mounting bolts beforehand. (2 pcs. for each block).  
 ※Loosen the nut until just before it separates from the bolt.

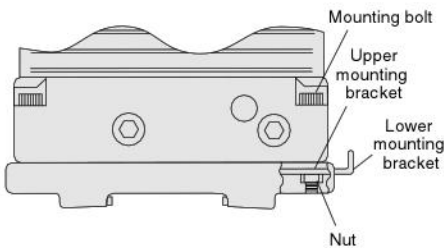

- ② Tilt the manifold and latch one side of the lower hook (area A) onto the DIN rail edge.

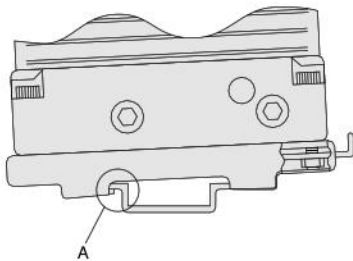

- ③ Set the manifold parallel to the DIN rail, and slide the lower bracket so that the other hook (area B) also latches onto the DIN rail. Leave it loose as it slides, and then alternately tighten the mounting bolts.

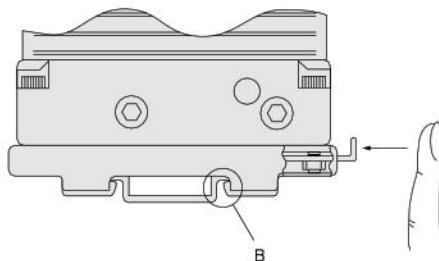

- ④ Completion

#### Removing procedure

When removing, follow the reverse mounting procedure for easy removal.

### Replacement of the muffler

For replacement of the muffler when using the built-in muffler type piping module (FM-PR-F□), follow the procedure shown below:

Order code for muffler only: F3PR-01

#### Replacing procedure

- ① Remove the mounting screws (6 pcs.) securing the air supply/exhaust block.
- ② Remove the muffler to be replaced. (At this time, take caution to avoid losing the gasket.)
- ③ Attach the gasket to the seat of the base, and insert the new muffler until it reaches the bottom of the groove.
- ④ Set the air supply/exhaust block in the normal position ①, and tighten the mounting screws. (Tightening torque: 17.2N·cm {1.75kgf·cm} [1.52in·lbf]).
- ⑤ Completion

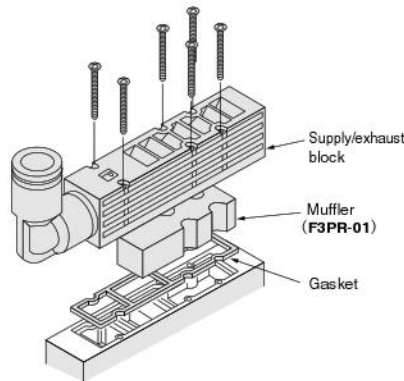

### Replacement of valves

#### Removing procedure

Remove the 2 mounting screws (4 pcs. for the twin solenoid), and lift in the direction shown by the arrow (see the illustration). Because the solenoid is a plug-in type, moving it in any other direction than that indicated by the arrow could damage the terminals.

#### Mounting procedure

Mount new gaskets on the valve. Then, set the solenoid terminal into the insert opening, and tighten the mounting screws. (Tightening torque: 17.2N·cm {1.75kgf·cm} [1.52in·lbf]).

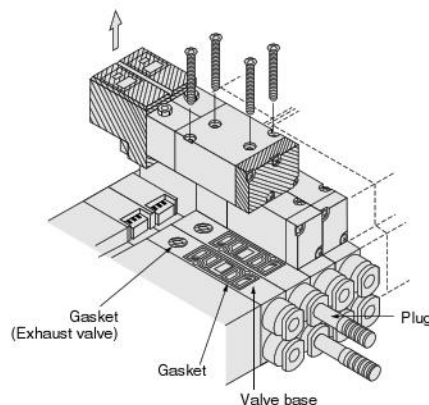

### Adding on modules

If disassembling this manifold for the purpose of adding units, etc., the gaskets and internal wiring could be damaged, or during re-assembly the gasket could be caught in the gap, or the wiring could become defective, etc. For this reason, avoid disassembly or re-assembly after delivery. (The manifold is checked before shipping for energizing, air leaks, etc.)  
 However, if you must add units to the manifold for some reason, consult us.