

Seven Features of the Koganei Vacuum Valve

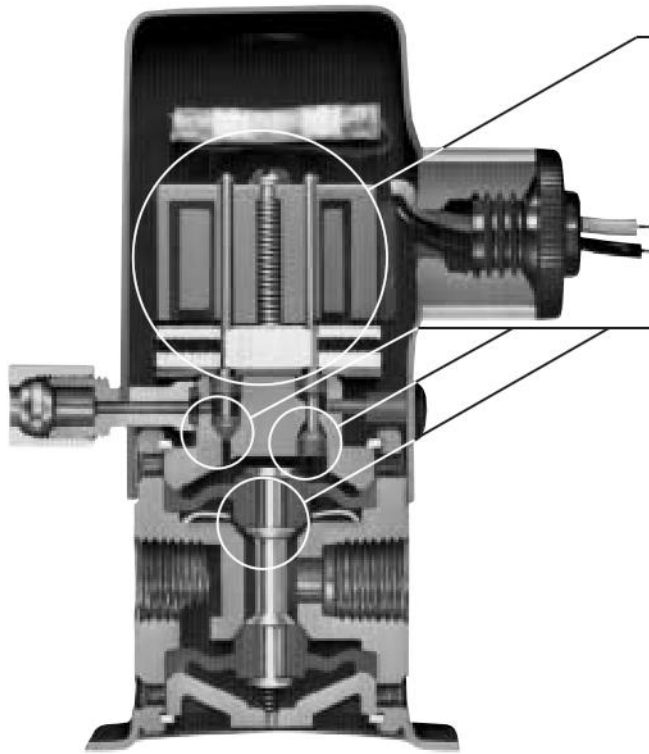

Koganei Original Solenoid Construction

- ① **No burning damage to solenoid**
No need to stock solenoids as spare parts.
- ② **Starting and energizing current values are extremely small.**
Allows for more compact size peripheral electrical equipment.

Poppet and Diaphragm Construction

- ③ **No sliding parts**
No valve sticking, for reliable operations.
- ④ **Extremely few cases of vacuum leakage**
Good vacuum response enables excellent pick-up by a vacuum pad and compact vacuum pump to install.
- ⑤ **Dust-resistant**
Can be used by installing just an ordinary air filter, even in dusty locations.
- ⑥ **Can be used without lubrication.**
Optimum valve for equipment incapable of using oil.
- ⑦ **Compact and lightweight, with any mounting direction acceptable**
Can be easily mounted to control panel, and allows for more compact equipment.

Application Examples

Opening bags

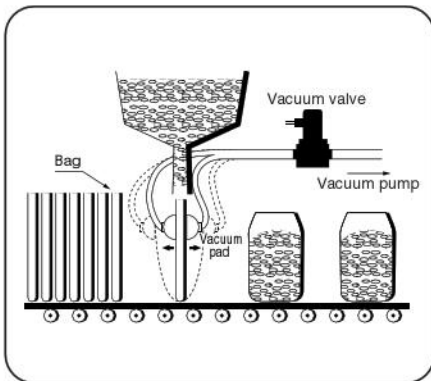

Quick charging of liquids

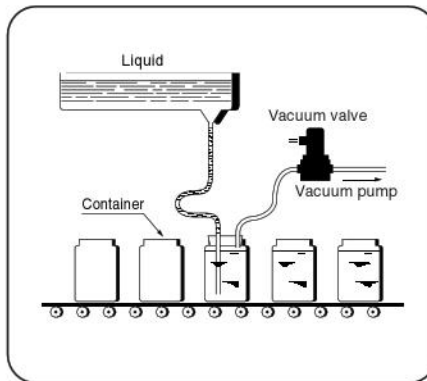

Paper feeding for printers

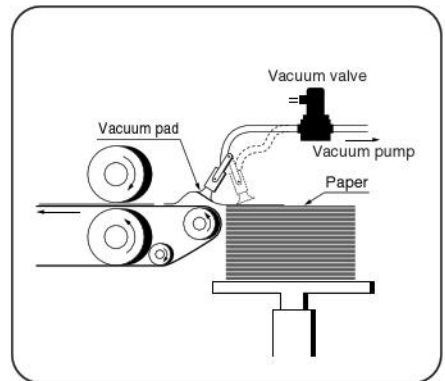

Vacuum forming machines

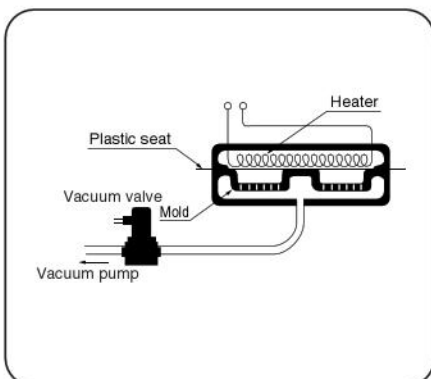

Discriminating product facing

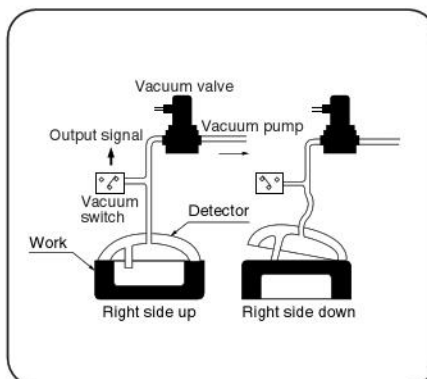

Labeling on cardboard boxes

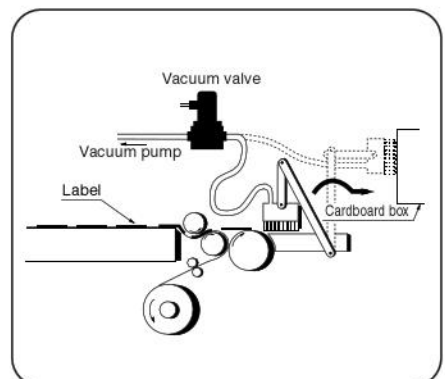

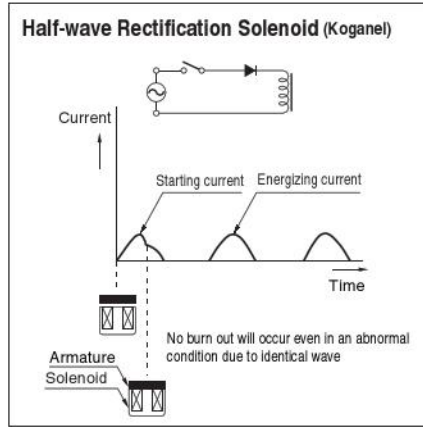
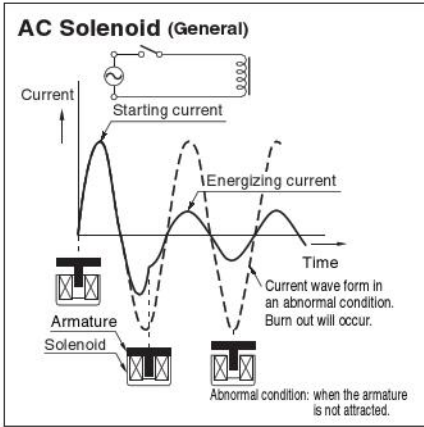

Koganel's ingenious self-developed solenoid

A silicon diode is installed on the end of the solenoid for half-wave rectification of the alternating current. The solenoid, therefore, possesses midway characteristics between the AC solenoid and DC solenoid. In addition, since the armature is designed to move as short a distance as possible, the starting current (inrush current) and energizing current are virtually identical and low current. As a result, the solenoid is not damaged even in abnormal conditions in which the armature fails to move, and the capacity of related electrical equipment can remain low.

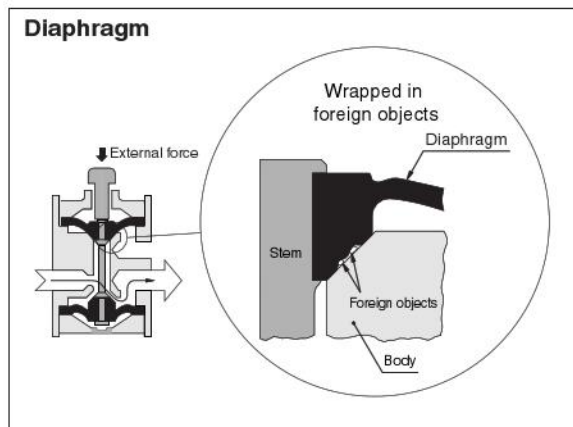
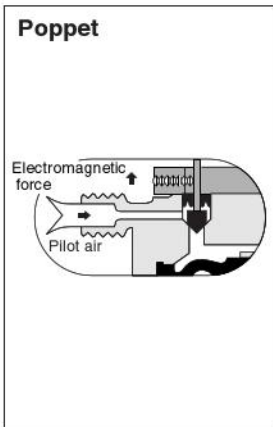



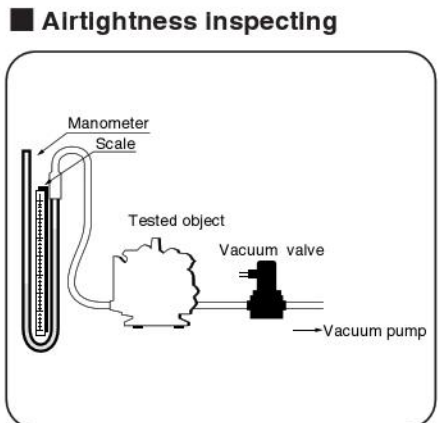
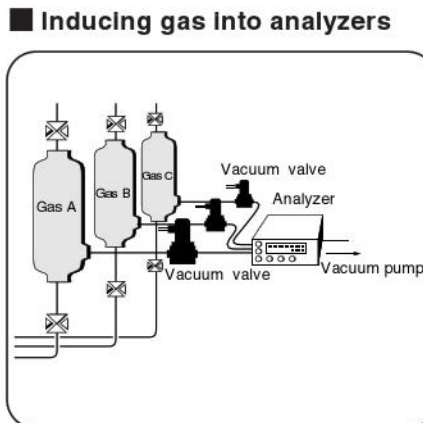
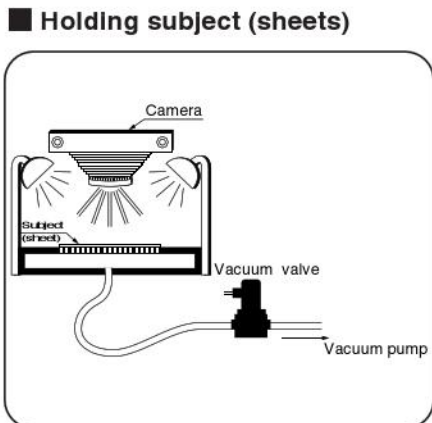
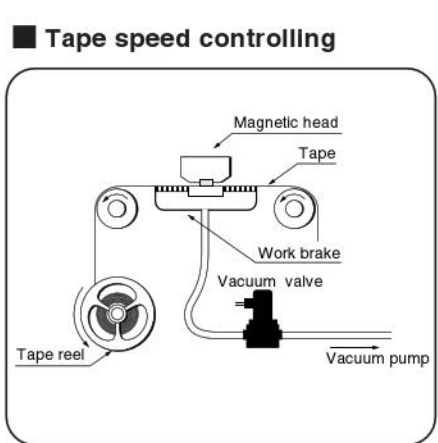
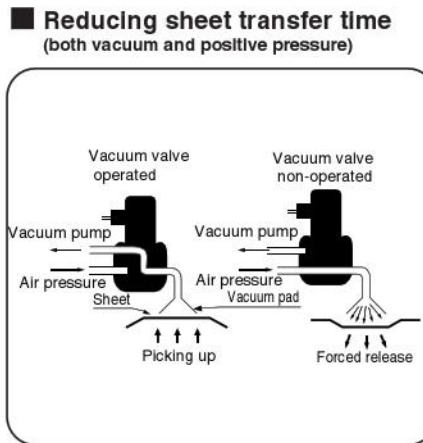
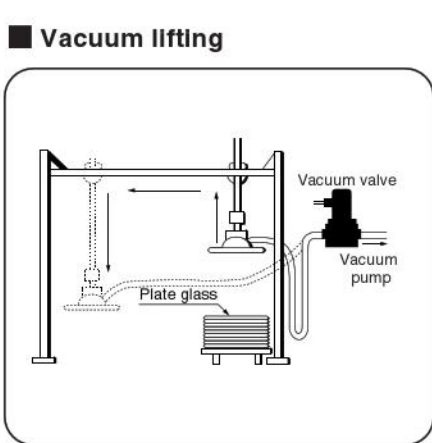

Poppet and diaphragm construction

The synthetic rubber poppet and diaphragm are built into the stem and move as one-piece. The poppet and diaphragm do not have any sliding surfaces, therefore no sticking occurs even without lubrication. In addition, the units have the elasticity of synthetic rubber to wrap in small foreign objects and keep vacuum leaks to an extremely low level.

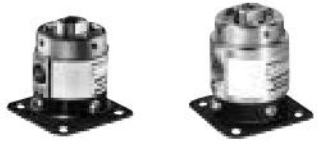

<Product Range>

Products	Shape	Operation type		Port size Rc	Port	Function	Effective area (Cv) mm ²	Model	Page		
Solenoid vacuum valve		Single solenoid	Direct acting	1/4	2, 3	●NC ●NO	2.5 (0.12)	V062E1	961		
					3		5.5 (0.27)	SV062E1 (Both vacuum and pressure type)			
					2		15 (0.76)	V126E1			
			Indirect acting { External air pilot }	3/8	55 (2.7)		VA250AE1	964			
				1/2	15 (0.76)		VA2503AE1				
				1/4	55 (2.7)		VA500AE1				
		Indirect acting { External vacuum pilot }	3/8	15 (0.76)	VV250AE1	964					
			1/2	55 (2.7)	VV2503AE1						
			1/4	55 (2.7)	VV500AE1						
		Double solenoid (Continuously energizing type)	Indirect acting { External air pilot }	1/4	3	●NC/ NO	15 (0.76)	VA250AE2	964		
							3/8	55 (2.7)		VA2503AE2	
							1/2	55 (2.7)		VA500AE2	
Manual vacuum valve and foot vacuum valve		Push button	Spring return	1/8	3	●NC	5.5 (0.27)	V125P	970		
							With holding mechanism	1/4		15 (0.76)	V250P
								3/8		15 (0.76)	V2503P
		Lever	Holding type	1/8	3	●NC/ NO	5.5 (0.27)	V125HO			
							1/4	15 (0.76)		V125V	
							3/8	15 (0.76)		V250V	
				5	1/4		15 (0.76)	V2503V			
					1/4		15 (0.76)	V250-4H			
					3/8		15 (0.76)	V2503-4H			
		Foot	Pedal type	1/4	2, 3	●NC	15 (0.76)	V250F			
		Mechanical operated vacuum valve		Ball-cam		1/8	3	●NC		5.5 (0.27)	V125B
1/4	15 (0.76)								V250B		
	3/8								15 (0.76)	V2503B	
Roller-cam	Nylon roller			1/4	2, 3	●NC	15 (0.76)	V250C			
				3/8	15 (0.76)		V2503C				
	Steel roller One way steel roller			1/8	3		5.5 (0.27)	V125MC			
							5.5 (0.27)	V125MOC			
Piloted vacuum valve		Air pilot (single)		1/8	3	●NC	5.5 (0.27)	VA125A	976		
							1/4	15 (0.76)		VA250A	
								3/8		15 (0.76)	VA2503A
		1/2	55 (2.7)	VA500A							
			Vacuum pilot (single)		1/4		15 (0.76)	VV250A			
					3/8		15 (0.76)	VV2503A			
	1/2	55 (2.7)			VV500A						
		Double air pilot		1/4	2, 3	●NC/ NO	15 (0.76)	250A2	979		
							3/8	55 (2.7)		2503A2	
							1/2	140 (7)		500A2	
							3/4	280 (14)		750A2	
							1	280 (14)		1000A2	

Safety Precautions (Solenoid Vacuum Valve Series)



Warnings

1. When mounting a valve inside a control panel or when an operation requires long energizing periods, provide heat radiation measures to ensure that the ambient temperature always remains within the temperature range specifications. For long term continuous energizing, consult us.
2. Always check the Catalog, etc., when carrying out wiring and piping of products to ensure that the connections are correctly done. Wrong wiring or piping could result in abnormal operation to the actuator, etc.
3. The solenoid valve's silicon diode could be damaged by surge voltage when a large induction load is used on the same power supply. Either change to a separate power supply, or mount a surge absorber to protect the unit. Solenoids with surge suppression are also available. Consult us.



Caution

For locations subject to water or to large amounts of dust, use a cover, etc., to protect the valves. Also, install a muffler, etc., to the R port to prevent dust from entering. Intrusion of water or dust could result in short-term functional shutdowns, sudden drops in performance, or a reduced operating life.



Attention

1. Use clean air that does not contain degraded compressor oil, etc., and install a filter, etc., close to solenoid valves to remove dust or collected liquid.
2. Ensure that the piping port on the supply side is at the same area or larger than the solenoid valve's effective area.
3. When using an indirect acting valve, use a stop valve between it and the pressure source. When the stop valve is opened before the pressure reaches the minimum operating pressure, the indirect acting valve could fall into a neutral position. (All solenoid valves in the 250 series and up are indirect acting valves.)
4. When connecting 2 or more AC type solenoid valves to the same power supply, connect leads with the same lead wire color.
5. Since a diode is connected to the AC type solenoid valve, the solenoid may sometimes not turn on with the solid state-type relay (SSR) with zero-cross function. For this reason, pay attention before use to the ratings and precautions for use of the solid state-type relay.

Voltage Types and Current

Rated voltage V		Current A ^{Note}	
		50Hz	60Hz
AC	230 [*]	0.063	0.055
	220 [*]	0.058	0.072
	200	0.070	0.065
	115 [*]	0.13	0.11
	110 [*]	0.12	0.16
	100	0.14	0.13
	48 [*]	0.41	0.37
	24 [*]	0.93	0.83

Note: The starting current and energizing current values are virtually identical, and fall within these values.

Rated voltage V		Current A
DC	200 [*]	0.04
	110 [*]	0.08
	100 [*]	0.09
	48 [*]	0.19
	24	0.40
	12 [*]	0.75
	6 [*]	1.50

For ※ items, consult us for the delivery.

Wiring Instructions of Double Solenoid (E2) Type

This valve has 2 solenoids built into the top and mid section, and the lead wires are color-coded with vinyl tape. Energizing the red tape side (the upper side, solenoid S2) opens the valve, and energizing the gray tape side (the lower side, solenoid S1) closes the valve. This solenoid is a continuous energizing holding type.

Solenoid S1 energized

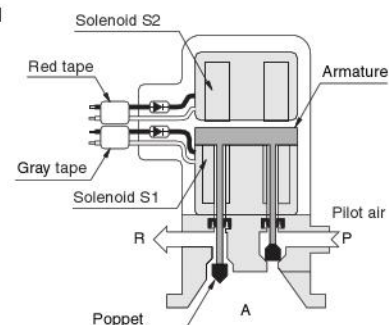

Piloted Vacuum Valves

Double Air Pilot Type



Specifications

Item	Basic model	250A2	2503A2	500A2	750A2	1000A2
Media		Vacuum				
Operation type		Air pilot				
Number of ports		2, 3 ports				
Valve function		NC/NO				
Effective area [Cv] mm ²		15 [0.76]		55 [2.7]	140 [7]	280 [14]
Port size Rc		1/4	3/8	1/2	3/4	1
Lubrication		Not required				
Operating pressure range kPa (mmHg) [in.Hg]		0~100 [0~-750] [0~-29.53]				
External pilot pressure		Recommended air pressure 0.2~0.3MPa [29~44psi.] MAX. 0.7MPa [102psi.]		Recommended air pressure 0.2~0.3MPa [29~44psi.] MAX. 0.5MPa [73psi.]	Recommended air pressure 0.2~0.3MPa [29~44psi.] MAX. 0.7MPa [102psi.]	
Operating temperature range °C [°F]		5~60 [41~140]				
Mounting direction		Any				
Mass kg [lb.]		0.2 [0.44]	0.25 [0.55]	0.45 [0.99]	1.8 [4.0]	2.7 [6.0]

Remark: In addition to the above, the Rc 1/8 type of 125 A2 is available.

Order Codes

		Basic model		Option	
				Valve function	
Double air pilot	2-, 3-port	250A2		-2	
	2-, 3-port	2503A2			
	2-, 3-port	500A2			
	2-, 3-port	750A2			
	2-, 3-port	1000A2			

●Blank: 3-port (NC/NO)

Operating Principles and Symbols

Diaphragm type (250A2, 500A2)

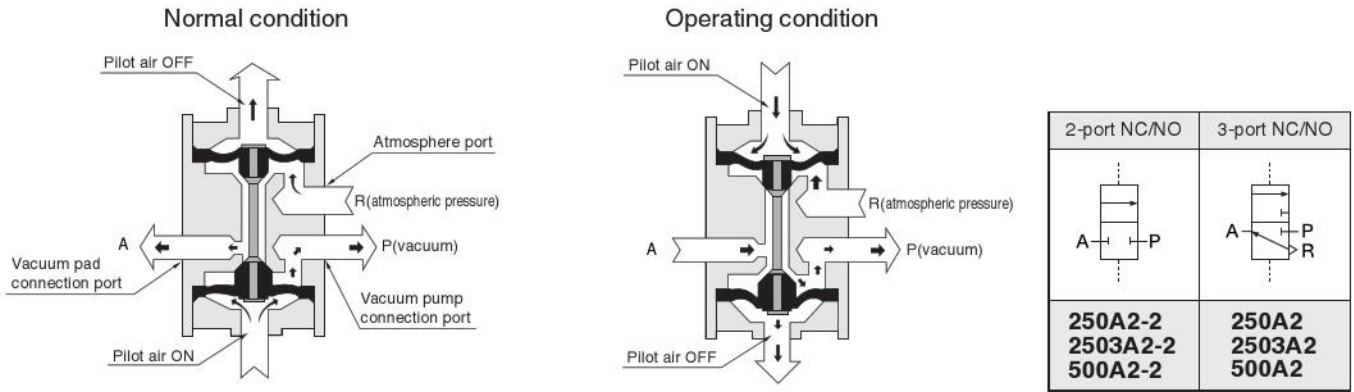

Piston poppet type (750A2, 1000A2)

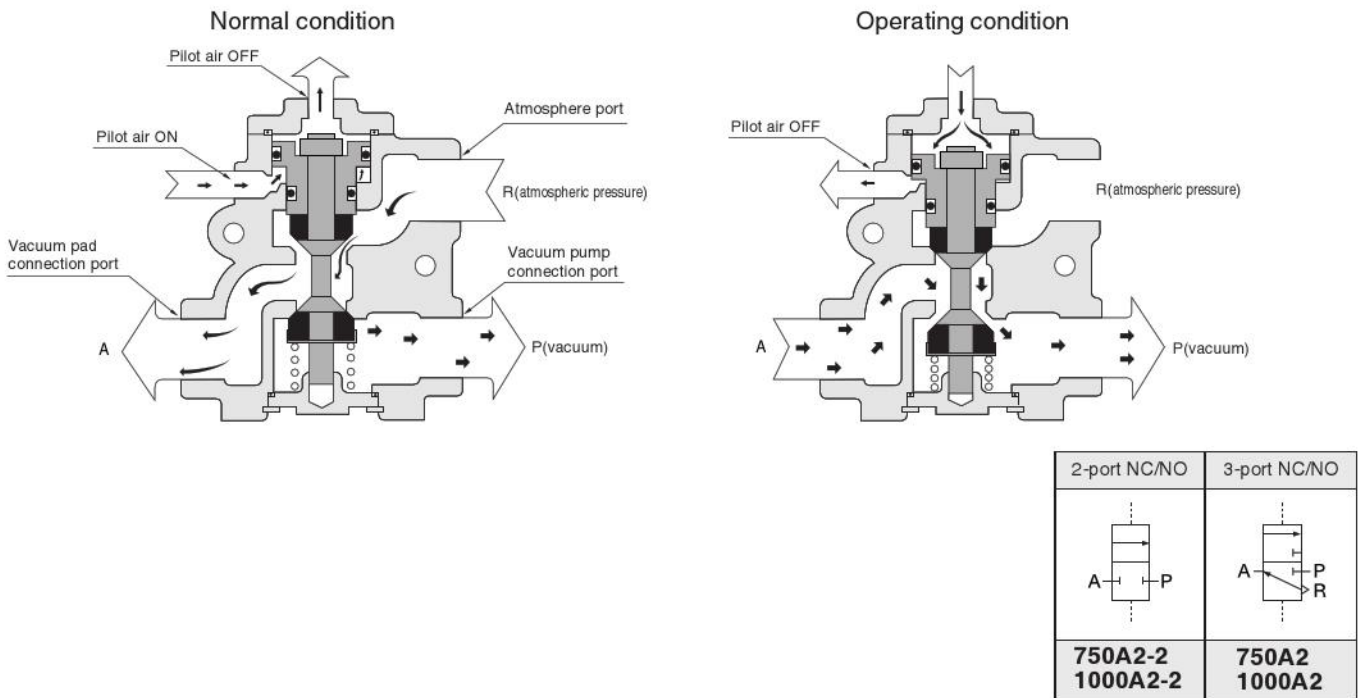

Dimensions (mm)

250A2 2503A2

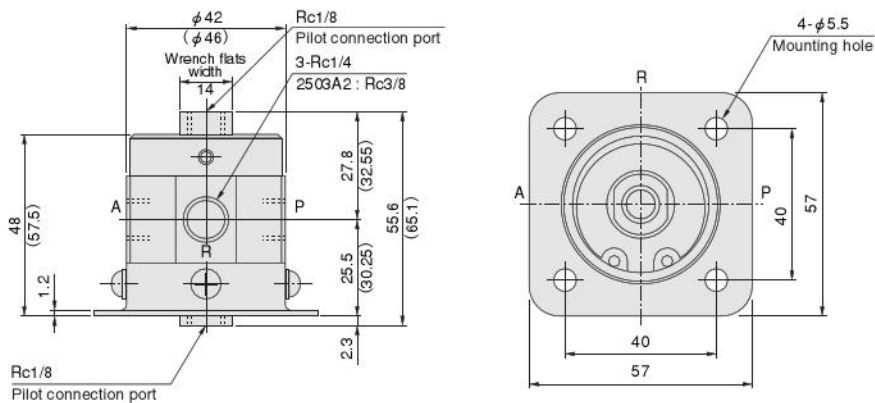

Dimensions (mm)

500A2

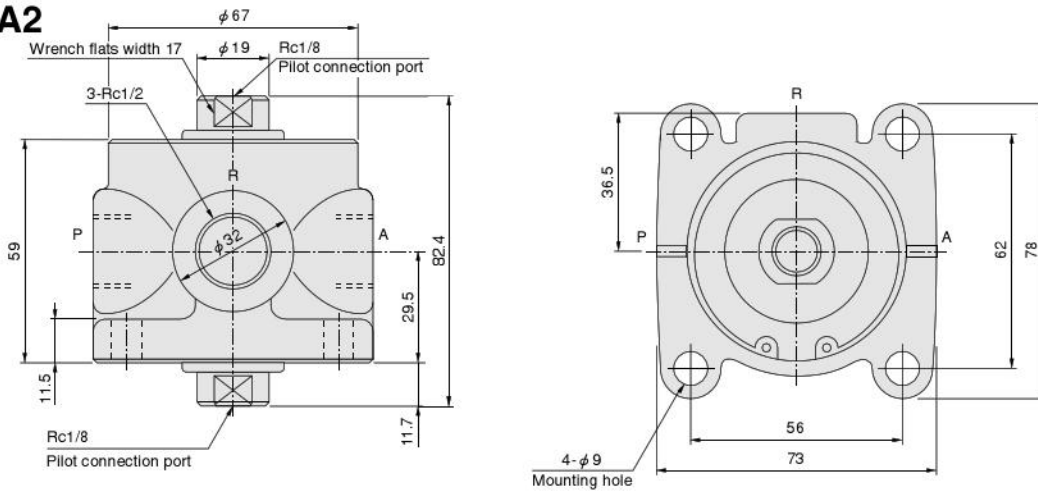

750A2

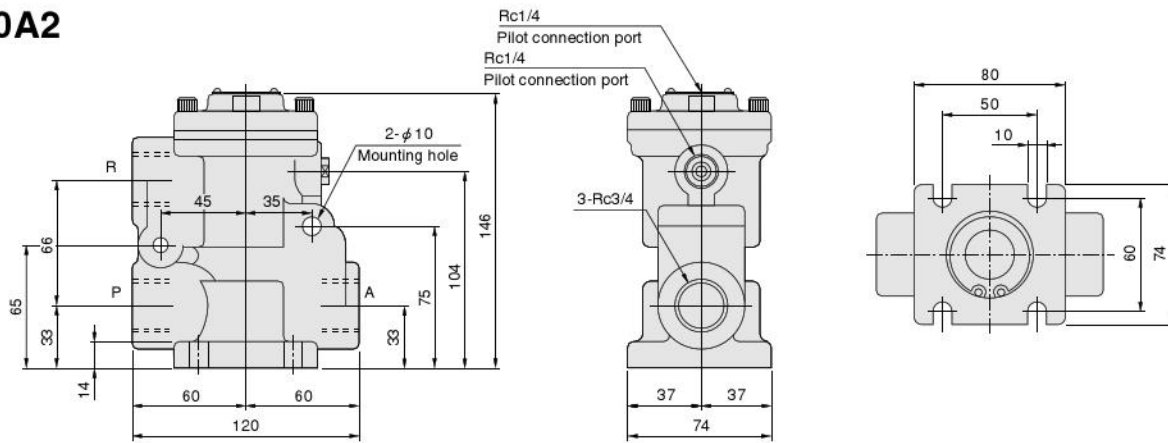

1000A2

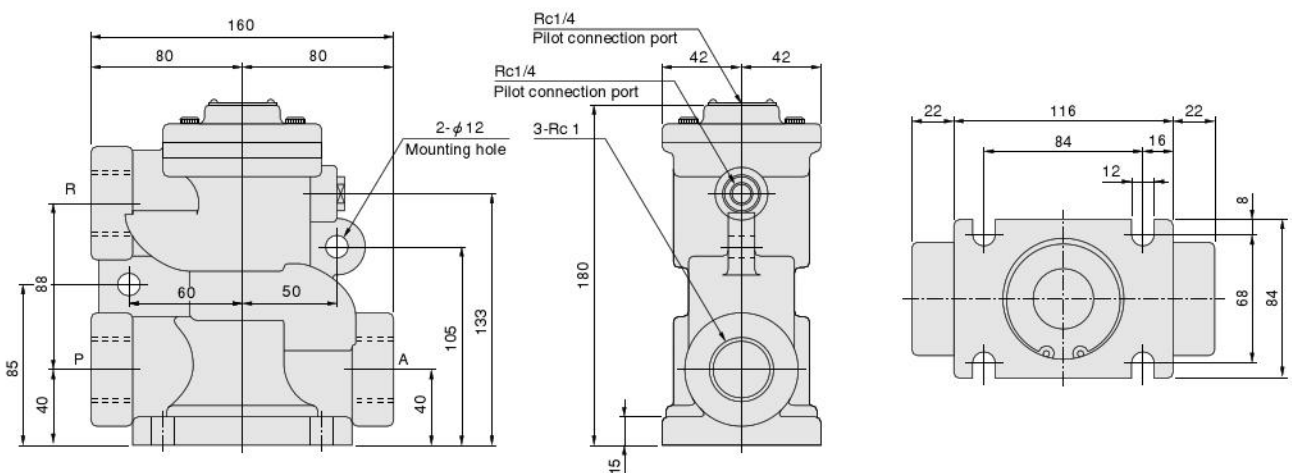

Reference

Vacuum Valve Selection Table (Exhaust and Air Supply Response Times)

S

Vacuum kPa [in.Hg]	50cc [3.05in. ³] chamber				200cc [12.2in. ³] chamber				1 l [61in. ³] chamber				3 l [183in. ³] chamber				5.5 l [336in. ³] chamber				10.5 l [641in. ³] chamber							
	Exhaust ^{*)}		Air supply		Exhaust		Air supply		Exhaust		Air supply		Exhaust		Air supply		Exhaust		Air supply		Exhaust		Air supply					
	0	0	-81.3 [-24.01]	-42.6 [-12.58]	0	0	-81.3 [-24.01]	-42.6 [-12.58]	0	0	-81.3 [-24.01]	-42.6 [-12.58]	0	0	-81.3 [-24.01]	-42.6 [-12.58]	0	0	-81.3 [-24.01]	-42.6 [-12.58]	0	0	-81.3 [-24.01]	-42.6 [-12.58]	0	0	-81.3 [-24.01]	-42.6 [-12.58]
Model	-81.3 [-24.01]	-42.6 [-12.58]	0	0	-81.3 [-24.01]	-42.6 [-12.58]	0	0	-81.3 [-24.01]	-42.6 [-12.58]	0	0	-81.3 [-24.01]	-42.6 [-12.58]	0	0	-81.3 [-24.01]	-42.6 [-12.58]	0	0	-81.3 [-24.01]	-42.6 [-12.58]	0	0	-81.3 [-24.01]	-42.6 [-12.58]	0	0
V062E1	0.2	0.08	0.18	0.1	0.7	0.35	0.5	0.38	3.0	1.5	2.5	1.8	9.0	3.2	6.0	4.0	20.0	8.0	14.0	10.0								
V126E1	0.12	0.05	—	—	0.4	0.2	—	—	1.8	0.9	—	—	5.0	1.7	—	—	11.0	3.5	—	—								
VA125A	0.1	0.06	0.13	0.12	0.35	0.15	0.3	0.2	1.6	0.7	1.3	0.8	3.8	1.4	2.6	1.8	9.0	3.4	6.0	4.0								
VA250AE1	0.05	0.03	0.09	0.04	0.1	0.05	0.08	0.07	0.5	0.23	0.16	0.18	1.1	0.4	0.7	1.0	2.4	1.0	1.7	1.0								
VA500AE1	0.04	0.03	0.14	0.14	0.07	0.05	0.14	0.14	0.25	0.1	0.15	0.18	0.5	0.2	0.4	0.3	1.1	0.4	0.6	0.5	2.0	0.8	1.0	0.8				
1000A2	—																0.26	0.14	0.26	0.2	0.4	0.2	0.4	0.3				

Note: The exhaust vacuum in the chamber is a 80% rating value of the vacuum inside of the primary tank.

The above table shows the time it takes from the point in time where the vacuum valve is switched ON to reach the specified vacuum inside of the chamber, and the time from switching the vacuum valve OFF to supply air into the chamber.

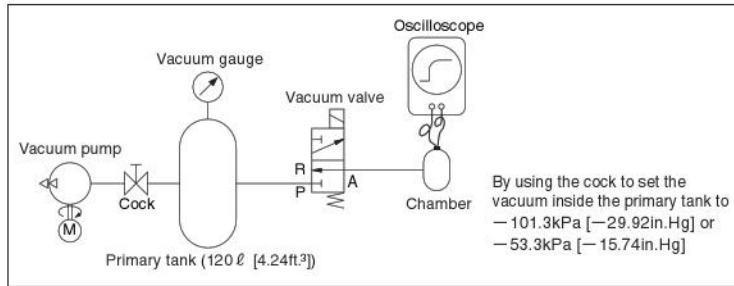

Standard Vacuum Circuit

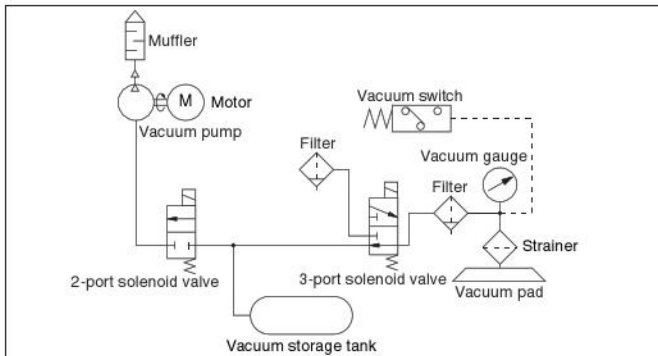

Inspection Standard for Vacuum Leaks (Koganei standards)

Inspection procedure

Open valve A, and set the vacuum in the tank to -100kPa [-750mmHg] [-29.53in.Hg]. Afterward, close valve A, let set for 10 minutes, and then check the vacuum inside of the tank both during OFF and ON.

Inspection standard

Let set for 10 minutes, then check to see that the vacuum leaks inside the tank meets the standard of 1.3kPa (10mmHg) [0.38in.Hg] or less.

For details, consult us.

Remark

In fact, most Koganei vacuum valves can hold initial vacuum even after being left set for 10 minutes.

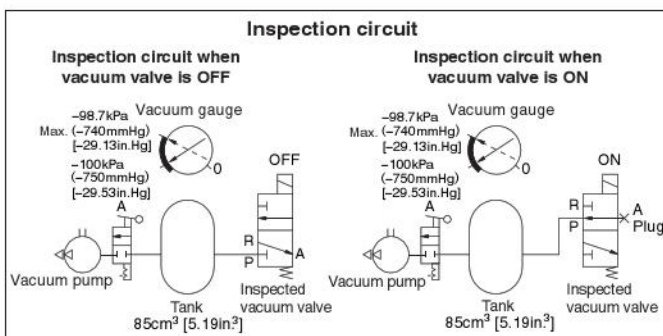

Calculation of Picking-up Force, and Graph (Theoretical values)

When using a vacuum pad to hold picking-up an object, the picking-up force is shown by the following formula.

$$W = P \times A \times 0.1$$

W: Picking-up force (N)
P: Vacuum (kPa)
A: Pad area (cm²)

<Conventional units>

$$W' = \frac{P'}{760} \times 1.033 \times A'$$

W': Picking-up force (kgf)
P': Vacuum (mmHg)
A': Pad area (cm²)

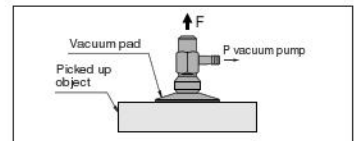

$$W'' = \frac{P''}{29.92} \times 14.7 \times A''$$

W'': Picking-up force [lbf.]
P'': Vacuum [in.Hg]
A'': Pad area [in.²]

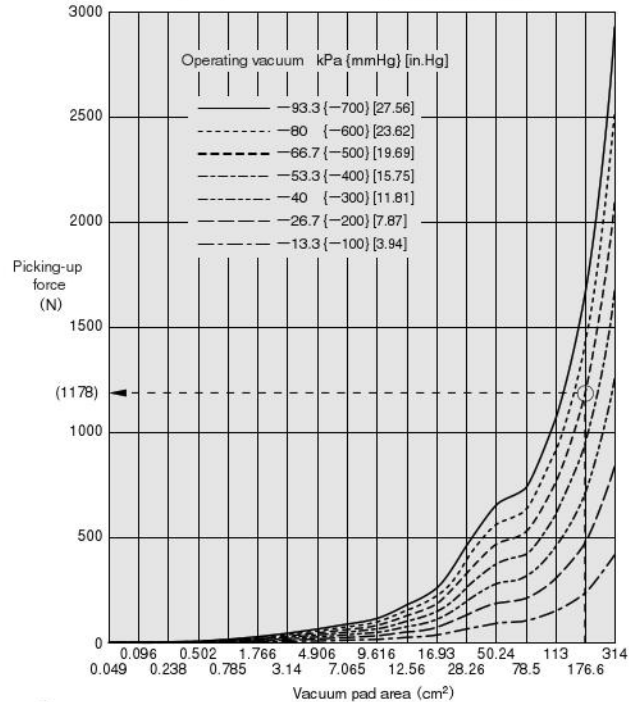

How to read the graph

When the vacuum is -66.7kPa [-19.7in.Hg], and the vacuum pad area is 176.6cm² [27.3in.²], the picking-up force is 1178N [265lbf.].

Reference

How to Use Both Vacuum and Pressure Type (SV062E1)

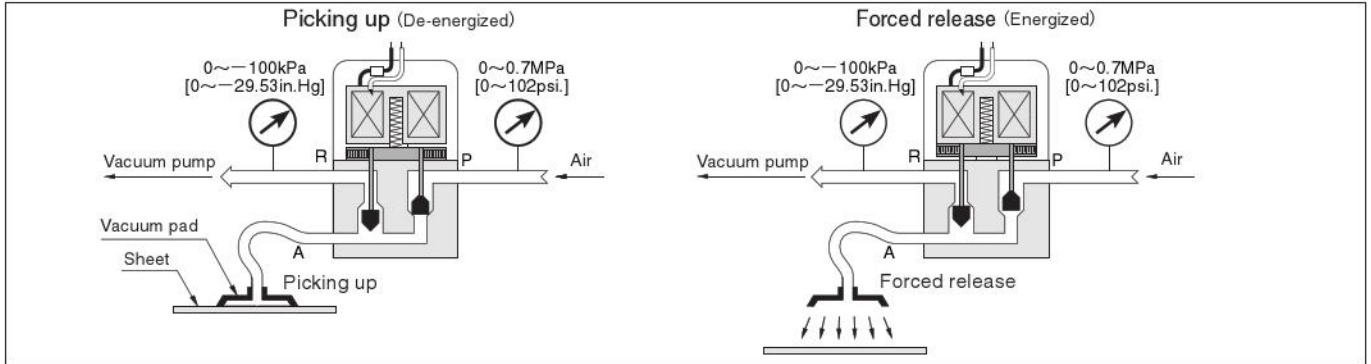

Application of External Air Pilot Type (VA250AE1/ VA2503AE1/ VA500AE1)

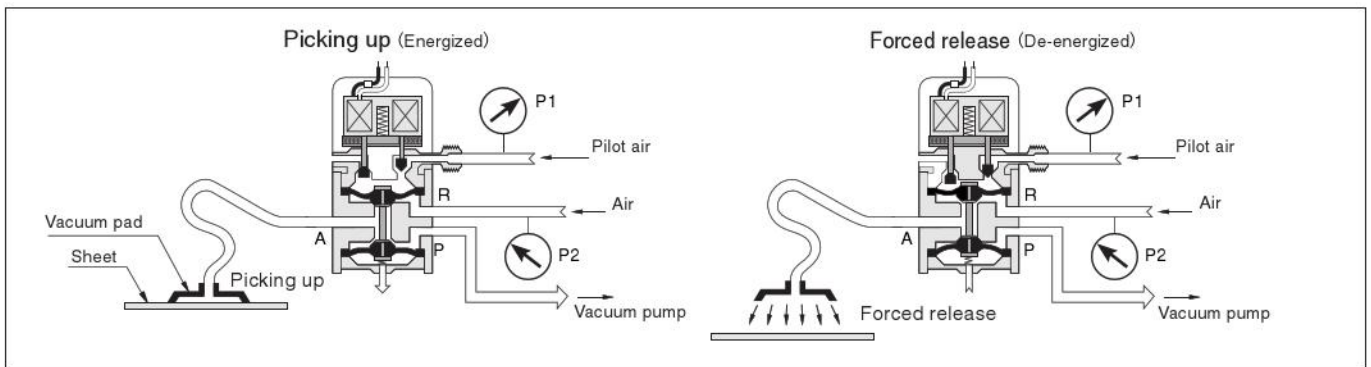

Note: Use as $P_1 > 2P_2$.

Application of External Double Air Pilot Type (250A2 / 500A2, etc.)

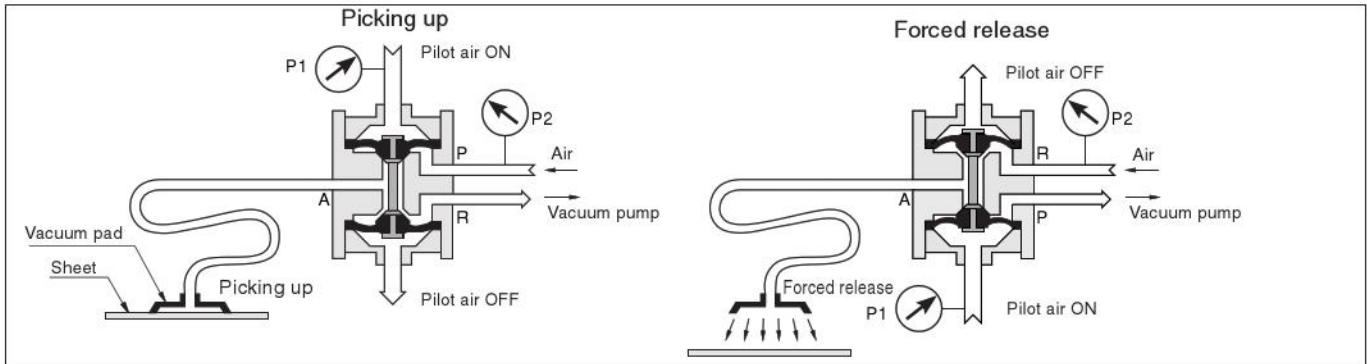

Note: Use as $P_1 > 2P_2$.

Pressure Unit Comparison Table

