

SMALL VACUUM REGULATORS

VR100



- Offer any vacuum pressure setting when mounted on vacuum lines.
- Push lock type regulator knob for light, smooth pressure regulation.
- Panel mounting is also a simple process, by opening holes in the panel.
- Suction flow rate VR100: MAX.45 l/min [1.59ft³/min.] (ANR)^{Note1}
- Lightweight (110g [3.88oz.]), compact (28×28×78mm [1.102×1.102×3.071in.])^{Note2}

Notes: 1. Values may change depending on operating conditions.
2. Excluding options.

Application Example

① Multiple vacuum pressured devices required

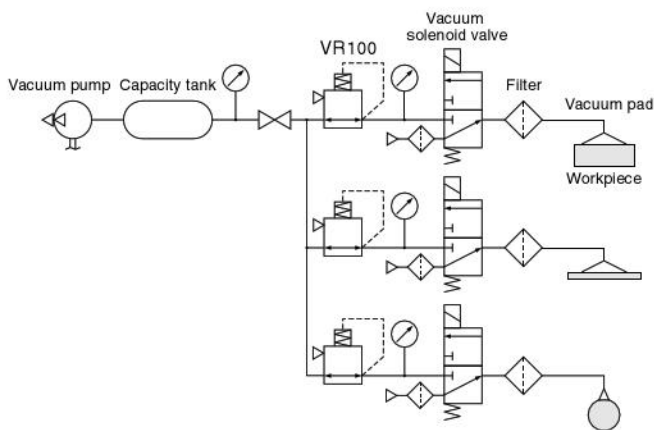

② Vacuum adjustment used for a vacuum packaging

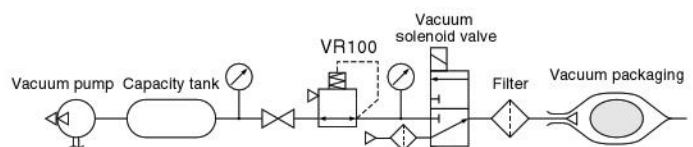

Symbol

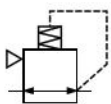

Operation Principle

When the knob is pulled firmly out, rotating the knob to the right applies compression force to the pressure regulating spring, acting through a diaphragm to lift up the pressure regulating valve assembly, which then passes through the VAC (vacuum pump side) and SET (pressure regulating side) to reduce pressure on the regulating side. The vacuum pressure on the pressure regulating side passes through a bypass hole to enter a chamber on the lower part of the diaphragm, activating the diaphragm. Here, it resists the compression force of the pressure regulating spring, with the VAC side and SET side closed by the valve assembly to obtain a balance that regulates the required vacuum pressure level. If vacuum pressure on the pressure regulating side falls below the setting value, air flows into the pressure regulating side from the atmosphere, maintaining the proper level.

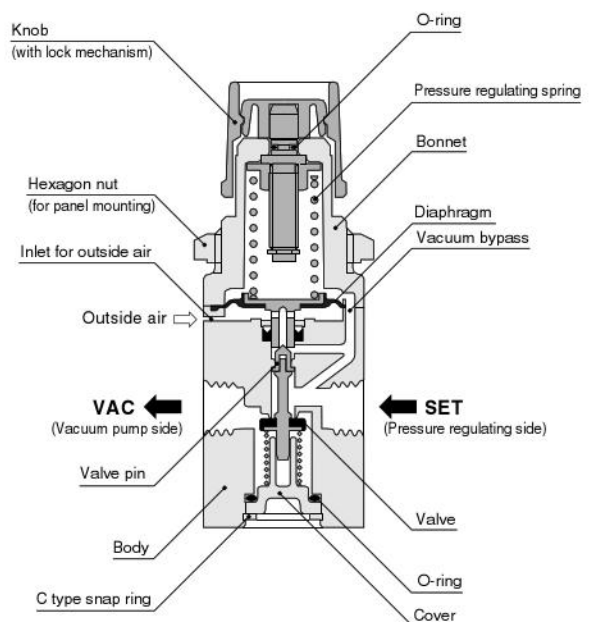

Specifications

Item	Model	VR100
Media		Air
Setting pressure range	kPa [in.Hg]	-6.5~100 [-1.9~29.54] ^{Note}
Setting pressure sensitivity	kPa [in.Hg]	0.26 [0.08] ^{Note}
Repeatability	kPa [in.Hg]	±0.8 [±0.24] ^{Note}
Proof pressure	MPa [psi.]	0.2 [29]
Suction flow rate	ℓ/min [ft. ³ /min.] (ANR)	MAX. 45 [1.6] ^{Note}
Operating temperature range	°C [°F]	5~60 [41~140]
Pressure characteristics	kPa [in.Hg]	ΔP=4 [1.2]
Port size		M5×0.8, Rc1/8
Vacuum gauge connection port size	Rc	1/8
Mass	kg [lb.]	0.11 [0.24]

Note: Values may vary depending on conditions. These values do not guarantee performance in practical conditions. Please take note.

Order Codes

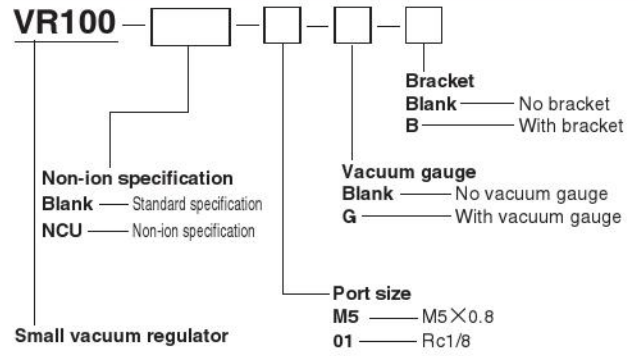

● Order codes for vacuum gauge only

GV-40-01 (Standard specification)

GV-40-01-NCU (Non-ion specification)

Flow Rate Characteristics

● VR100-M5

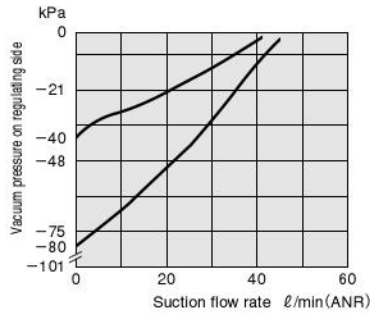

● VR100-01

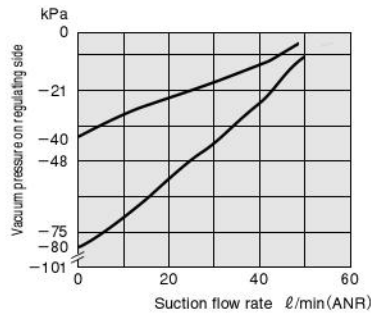

1 ℓ/min = 0.0353ft.³/min.
-100kPa = -29.54in.Hg

Pressure Characteristics

● VR100-M5

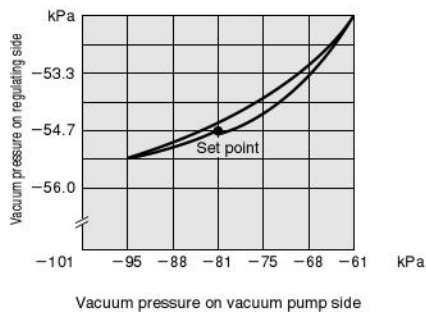

● VR100-01

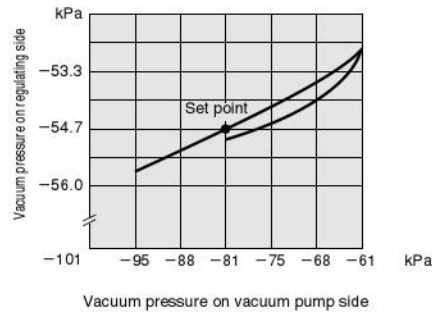

-100kPa = -29.54in.Hg

Dimensions of Small Vacuum Regulators (mm)

VR100

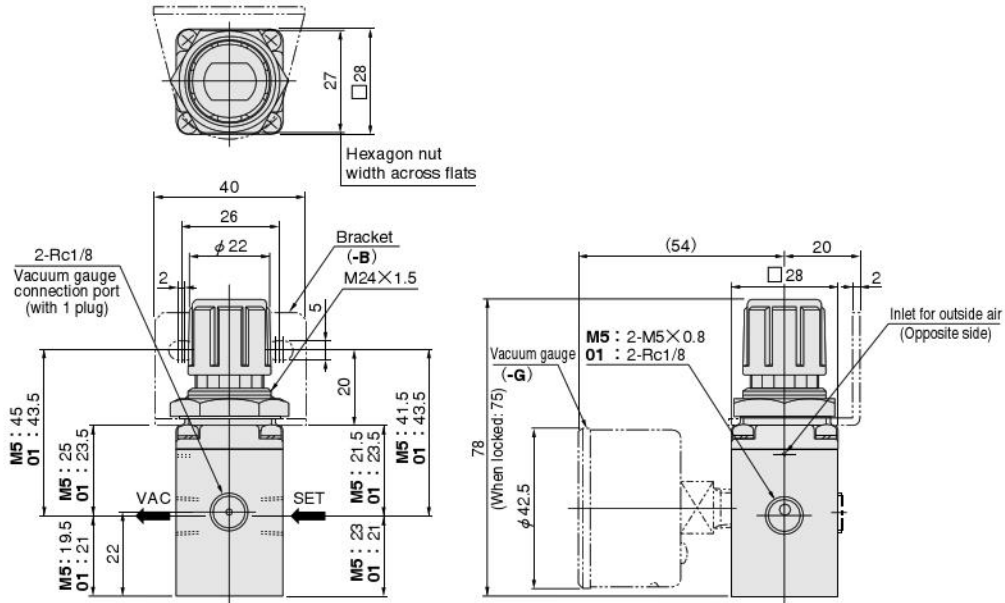

Remark: The mounting hole for installing the VR100 to a panel, etc., is $\phi 24.5$. For mounting, use the provided hexagon nut.

Dimensions of Vacuum Gauge (mm)

GV-40-01

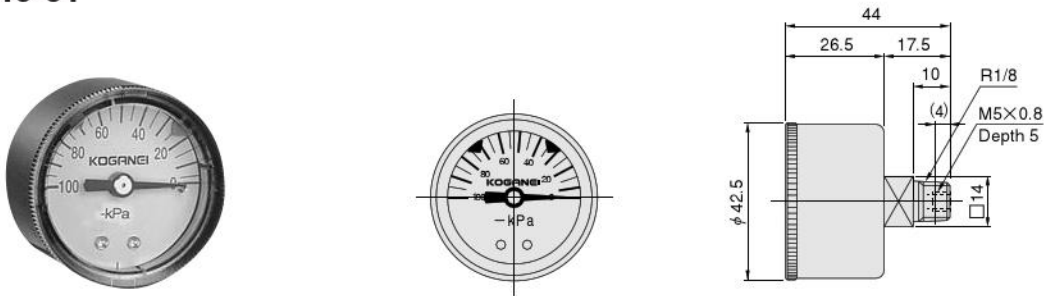

Inner Construction and Major Parts

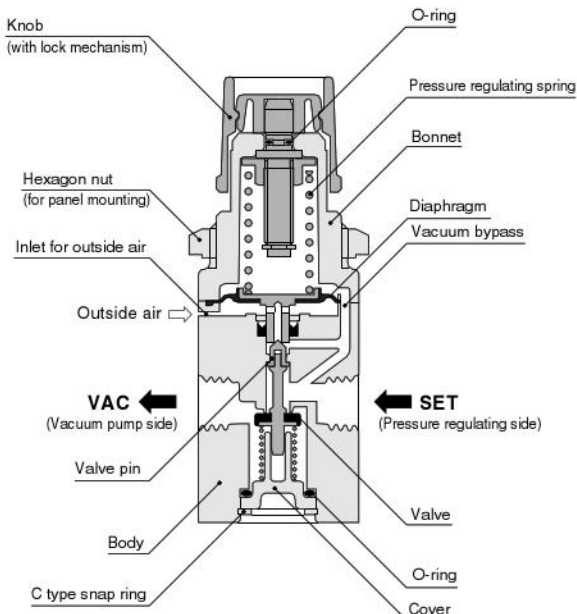

Vacuum Gauge Specifications

Item	Model	GV-40-01
Media		Air
Pressure indicator range	kPa [in.Hg]	0~-100 [0~-29.54]
Accuracy		F.S. $\pm 3\%$
Operating temperature range	$^{\circ}\text{C}$ [$^{\circ}\text{F}$]	5~60 [41~140]
Port size		R1/8 (female M5×0.8)
Mass	kg [lb.]	0.08 [0.18]

Major Parts and Materials

Parts	Materials
Body	Aluminum alloy
Bonnet	PBT
Knob	ABS
Diaphragm	Synthetic rubber (NBR)
Cover	Polyacetal
O-ring	Synthetic rubber (NBR)
Valve	Brass+Synthetic rubber (NBR)

Handling Instructions and Precautions



Pressure regulation

1. When regulating the pressure, connect a vacuum gauge to the vacuum gauge connection port (VR100: Rc1/8) on the vacuum regulator.
2. Always pull the knob out firmly to perform pressure regulation, rotating it to the right (clockwise) to reduce the pressure "atmospheric pressure → vacuum pressure" and rotating it to the left (counterclockwise) to increase the pressure "vacuum pressure → atmospheric pressure."
3. After regulating pressure, push the knob back into the body and lock it in place.



Caution: The vacuum regulator constantly sucks in a minute amount of atmospheric pressure air to maintain a balance. As a result, be careful to avoid blocking the body's inlet for outside air. Pressure cannot be set when the inlet hole is blocked.



Mounting and Piping

1. If mounting the vacuum regulator as a single unit, use a bracket (optional). A ring nut can also be used for panel mounting.
2. While any mounting direction is acceptable, mount so that the knob can be operated.
3. Do not perform any machining on the body of the unit, etc., for mounting. Its functions could be damaged.
4. For piping to the vacuum regulator, connect so that the VAC mark is on the vacuum pump side. Piping connections on the opposite side must not be made.
5. Since performance is affected by the capability of the vacuum pump used, take special care in selecting the vacuum pump. If the set pressure is undergoing a large change, either change the vacuum pump or change the piping. If the vacuum pump cannot be changed, install a capacity tank on the VAC side.



General precautions

1. Always thoroughly blow off (use compressed air) the piping before plumbing. Entering chips, sealing tape, rust, etc., generated during plumbing could result in air leaks or other defective operation.
2. Use air for the media. For the use of any other media, consult us.
3. If using in locations subject to dripping water, dripping oil, etc., or to large amounts of dust, use something to cover and protect the unit.