

KOGANEI

ACCESSORIES GENERAL CATALOG

AIR TREATMENT, AUXILIARY, VACUUM,
AND FLUORORESIN PRODUCTS

TUBES CONTENTS

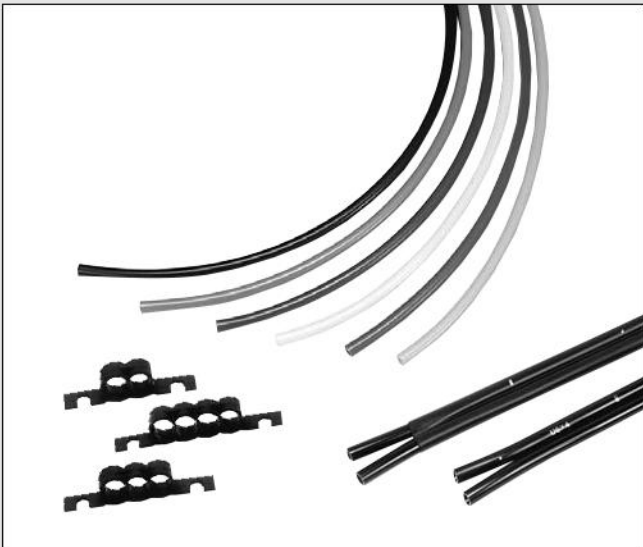

Nylon Tubes	
Specifications, Order Codes	489
Soft Nylon Tubes	
Specifications, Order Codes	490
Urethane Tubes	
Specifications, Order Codes	491
Flat Tubes	
Specifications, Order Codes, Handling Instructions and Precautions	492
Tube Holders	
Order Codes, Dimensions	493
Handling Instructions and Precautions	494

 **Caution** Before use, be sure to read the "Safety Precautions" on p. 49.

TUBE HOLDERS



● Tube Holders enable binding of multiple tubes.

Order Codes

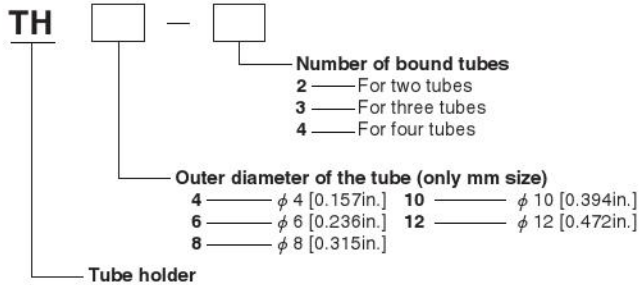

Remark: Standard products can be used as NCU specification.

Mounting Example

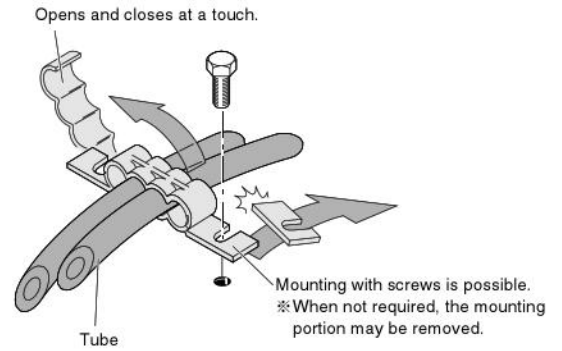

Dimensions (mm)

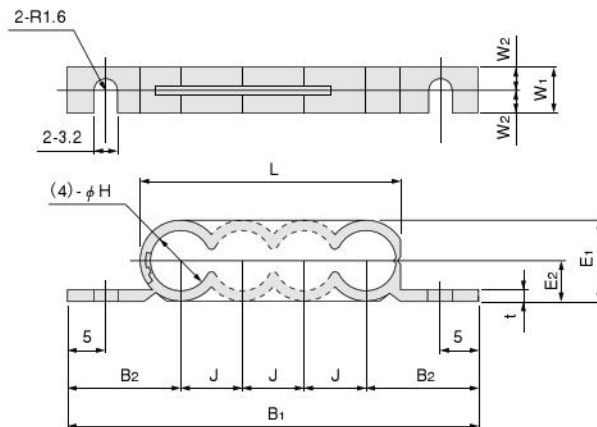

Model	Number of bound tubes	H Outer diameter of the tube	B ₁	B ₂	J	L	E ₁	E ₂	t	W ₁	W ₂	Mass g [oz.]
TH4-2	2	4	29.1	12.5	4.1	9.9	6.5	3.3	1.2	6	3	0.3 [0.011]
TH6-2		6	34.1	14	6.1	13.9	8.5	4.3	1.2			0.3 [0.011]
TH8-2		8	38.1	15	8.1	18.1	10.9	5.5	1.4			0.4 [0.014]
TH10-2		10	44.1	17	10.1	22.3	13.3	6.7	1.6			0.9 [0.032]
TH12-2		12	48.1	18	12.1	26.4	15.5	7.8	1.7			1.1 [0.039]
TH4-3	3	4	33.2	12.5	4.1	14	6.5	3.3	1.2	6	3	0.3 [0.011]
TH6-3		6	40.2	14	6.1	20	8.5	4.3	1.2			0.4 [0.014]
TH8-3		8	46.2	15	8.1	26.2	10.9	5.5	1.4			0.6 [0.021]
TH4-4	4	4	37.3	12.5	4.1	18.1	6.5	3.3	1.2	6	3	0.4 [0.014]
TH6-4		6	46.3	14	6.1	26.1	8.5	4.3	1.2			0.5 [0.018]
TH8-4		8	54.3	15	8.1	34.3	10.9	5.5	1.4			0.8 [0.028]
TH10-4		10	64.3	17	10.1	42.5	13.3	5.7	1.6			1.5 [0.053]
TH12-4		12	72.3	18	12.1	50.6	15.5	7.8	1.7			2 [0.07]



General precautions

1. Always thoroughly blow off (use compressed air) the tubing before piping. Entering chips, sealing tape, rust, etc., generated during piping work could result in air leaks or other defective operation.
2. Use air for the media. For the use of any other media, consult us.
3. Do not use in atmospheres where the temperature will exceed the operating temperature range.
Do not use in locations where sparks could occur, because the tube is not fire resistant.
4. The product cannot be used when the media or the ambient atmosphere contains any of the substances listed below.
Organic solvents, phosphate ester type hydraulic oil, sulphur dioxide, chlorine gas, or acids, etc.