

KOGANEI Twin Rod Cylinders

Compact design and requires no rod guides.

Can be installed directly onto equipment to minimize size.

Sensors mounted on three surfaces to facilitate detection.

Remarkable rod - no rotation accuracy Twice the cylinder thrust of conventional cylinders.

By adding new end keep cylinders with protective mechanisms and new long bushing cylinders to reinforce the bearing portion, twin rod cylinders can realize further space savings and at the same time reduce the number of production processes and lower cost.

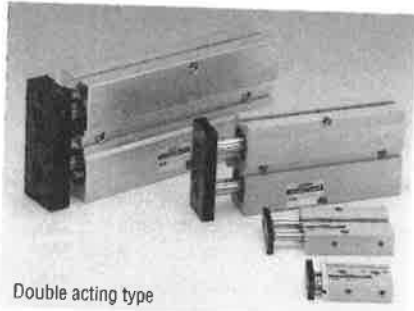

Double acting type



Double acting long bushing type

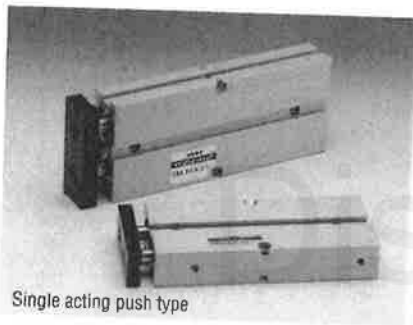

Single acting push type

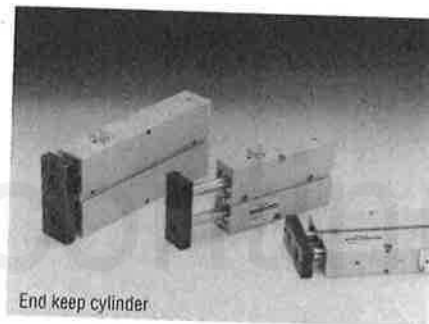

End keep cylinder

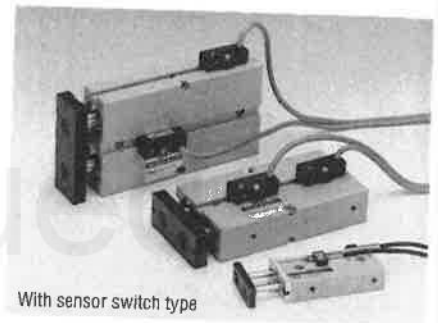

With sensor switch type

Selection chart

Operation Item	Cylinder bore size, mm	Stroke, mm	Sensor switches		Non ion specification
			Solid state type	Reed switch type	
Double acting type	⑥	10 20 30 40 50	ZC130 ZC153	CS5T CS11T	Not available
Double acting type	⑩ ⑫ ⑮ 25 32	10 20 30 40 50 60 70 80 90 100 $\phi 10 \rightarrow \phi 16 \cdot \phi 20 \cdot \phi 25 \cdot \phi 32$	CS9H ZB430	ZB333 ZB334 ZB131 ZB132 CS3H CS4H CS5H	Available on special order note
Double acting long bushing type	⑩ ⑫ ⑮ 25 32	10 20 30 40 50 60 70 80 90 100 $\phi 10 \rightarrow \phi 16 \cdot \phi 20 \cdot \phi 25 \cdot \phi 32$	CS9H ZB430	ZB333 ZB334 ZB131 ZB132 CS3H CS4H CS5H	Not available
Single acting push type	⑩ ⑫ ⑮ 25	10 20 30 40 50 60 $\phi 10 \cdot \phi 16 \cdot \phi 20 \cdot \phi 25$	CS9H ZB430	ZB333 ZB334 ZB131 ZB132 CS3H CS4H CS5H	Not available
End keep cylinders	⑩ ⑫ ⑮ 25	10 20 30 40 50 60 70 80 $\phi 16 \cdot \phi 20 \cdot \phi 25$	CS9H ZB430	ZB333 ZB334 ZB131 ZB132 CS3H CS4H CS5H	Not available

Note: Not available for $\phi 32$.

CYLINDER THRUST

An appropriate cylinder bore size should be selected depending on a required cylinder thrust taking into consideration load and air pressure. The chart below lists the calculated values. Select a cylinder bore size so that ratio to load (load factor = load / calculated value) is less than 70% (or less than 50% at high speed operation)

Cylinder bore size mm	Rod diameter mm	Operation	Pressure area mm ²	Air pressure MPa							
				0.1	0.2	0.3	0.4	0.5	0.6	0.7	
6	4	Double acting type	Push side	56	—	11.2	16.8	22.4	28	33.6	39.2
			Pull side	31	—	6.2	9.3	12.4	15.5	18.6	21.7
10	6	Double acting type	Push side	157	—	31.4	47.1	62.8	78.5	94.2	109.9
			Pull side	100	—	20	30	40	50	60	70
		Single acting push type	157	—	—	5.5	21.2	36.9	52.6	68.3	
16	8	Double acting type	Push side	402	40.2	80.4	120.6	160.8	201	241.2	281.4
			Pull side	301	30.1	60.2	90.3	120.4	150.5	180.6	210.7
		Single acting push type	402	—	39.3	79.5	119.7	159.9	200.1	240.3	
20	10	Double acting type	Push side	628	62.8	125.6	188.4	251.2	314	376.8	439.6
			Pull side	471	47.1	94.2	141.3	188.4	235.5	282.6	329.7
		Single acting push type	628	—	78.2	141	203.8	266.6	329.4	392.2	
25	12	Double acting type	Push side	981	98.1	196.2	294.3	392.4	490.5	588.6	686.7
			Pull side	755	75.5	151	226.5	302	377.5	453	528.5
		Single acting push type	981	—	115.8	213.9	312	410.1	508.2	606.3	
32	16	Double acting type	Push side	1607	160.7	321.4	482.1	642.8	803.5	964.2	1124.9
			Pull side	1205	120.5	241	361.5	482	602.5	723	843.5

Note 1: Minimum working pressure should be 0.2MPa for ø6mm double acting cylinders and ø10mm double acting long bushing cylinders.
2: The cylinder thrust values at stroke end for single acting push type with a 60mm stroke.

SPRING RETURNING FORCE (For Single Acting Type Only)

Cylinder bore size mm	Stroke mm	N	
		Zero stroke	Stroke end
10	10	16.5	20.6
	20	12.4	
	30	8.2	
	40	25.1	41.6
	50	21.0	
	60	16.9	
16	10	15.9	20.4
	20	11.1	
	30	6.3	
	40	22.3	41.1
	50	17.6	
	60	12.8	
20	10	19.6	23.5
	20	15.7	
	30	11.8	
	40	31.7	47.4
	50	27.8	
	60	23.8	
25	10	32.9	39.5
	20	26.2	
	30	19.5	
	40	53.7	80.4
	50	47.1	
	60	40.4	

Note; 1: The figures in the chart are values for two springs.
2: Use the unit so as not to impose load weight on the spring returning side

TWIN ROD CYLINDERS

Discontinued

AIR FLOW • AIR CONSUMPTION

Air flow and air consumption of twin rod cylinders can be calculated by the following formula. The quick-reference chart right can also be used to find the values.

$$Q_1 = \frac{\pi D^2}{4} \times L \times \frac{60}{t} \times \frac{P+0.101}{0.101} \times 10^{-6} \times 2$$

$$Q_2 = \frac{\pi D^2}{4} \times L \times 2 \times n \times \frac{P+0.101}{0.101} \times 10^{-6} \times 2$$

Q₁: Air flow necessary for cylinder, ℓ/min(ANR)
Q₂: Air consumption ℓ/min(ANR)
D: Cylinder bore size, mm
L: Cylinder stroke, mm
t: Time for one stroke of cylinder, s
n: Number of cylinder strokes per minute, stroke/min.
P: Air pressure, MPa

Air consumption per 1mm stroke

Cylinder bore size mm	Air pressure MPa						
	0.1	0.2	0.3	0.4	0.5	0.6	0.7
6	(0.223)	0.333	0.443	0.552	0.662	0.772	0.881
10	(0.620)	0.924	1.228	1.534	1.838	2.146	2.450
16	1.584	2.364	3.146	3.926	4.704	5.486	6.266
20	2.48	3.72	4.90	6.14	7.36	8.58	9.80
25	3.88	5.78	7.66	9.58	11.50	13.42	15.34
32	6.36	9.46	12.56	15.70	18.82	21.96	25.10

The figures in the chart are values to calculate air flow and air consumption of twin cylinder with 1mm reciprocating stroke.

The required values for air flow and air consumption can be calculated as follows.

To compute air flow of a cylinder (to select F.R.L. and valve, etc.)

Example 1 To operate a cylinder with a 20mm bore size at the speed of 300mm/s and at air pressure of 0.5 MPa.

$$7.36 \times \frac{1}{2} \times 300 \times 10^{-3} = 1.10 \text{ ℓ/s(ANR)}$$

$$\left(\text{The air flow per minute of the cylinder would be } 7.36 \times \frac{1}{2} \times 300 \times 60 \times 10^{-3} = 66.24 \text{ ℓ/min(ANR)} \right)$$

To compute air consumption of a cylinder:

Example 1 For one stroke with a 20mm bore size and a 50mm stroke twin rod cylinder at air pressure of 0.5 MPa

$$7.36 \times 50 \times 10^{-3} = 0.368 \text{ ℓ/per stroke (ANR)}$$

Example 2 For ten reciprocating strokes per minute with a 20mm bore size and a 50mm stroke twin rod cylinder at air

$$7.36 \times 50 \times 10 \times 10^{-3} = 3.68 \text{ ℓ / pressure of 0.5MPa}$$

Twin Rod Cylinders

Double Acting Type

Symbol

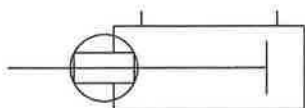

Specification

Item	Bore size (mm)	10	16	20	25	32
Operation		Double acting push type				
Fluid		Air				
Mounting type		Side mounting type				
Pressure range	MPa(kgf/cm ²)	0.15~0.7 {1.5~7.1}	0.1~0.7{1~7.1}			
Proof Pressure	MPa(kgf/cm ²)	1.03{10.5}				
Temperature	°C	0~60				
Piston speed range	mm/s	100~500				
Cushion		None	Rubber bumper			
Lubrication		Not required (If required, apply turbine oil class 1, ISO V632) or equivalent)				
Maximum rod rotation		±0.4°	±0.3°			
Stroke adjustment range	mm	-5~0 (per specific stroke)				
Port size		M5×0.8			Rc1/8	

Cylinder Bore Size and Stroke

Bore size	Standard stroke	Maximum stroke (available)	Pull stroke adjustment range
10	10, 20, 30, 40, 50, 60, 70	100	-5~0
16	10, 20, 30, 40, 50, 60, 70, 80, 90, 100	120	
20	10, 20, 30, 40, 50, 60, 70, 80, 90, 100	130	
25	10, 20, 30, 40, 50, 60, 70, 80, 90, 100	150	
32	10, 20, 30, 40, 50, 60, 70, 80, 90, 100	150	

Note 1: Contact us if you need to attach two sensor switches on the 10mm stroke of sensor cylinders.

2: Please consult us for delivery of cylinder with longer stroke than standard stroke.

Remark: Non-ion specification is same.

Order Example

TDA **16×30** - **NCU** - [] - [] - []

Cylinder bore size × Stroke
Non-ion specification ^{note 2}
 (custom order)
 Blank—Standard specification

Sensor switch model ^{note 3}

Lead wire length
A : 1000mm
B : 3000mm
 (B is the only two-color luminous type sensor switch)

Number of sensor switch
1 — With one sensor switch
2 — With two sensor switches
 (With one sensor switch only for ZB333, ZB334)

Twin rod cylinders
Double acting type ^{note 1}

CS9H — Three wire type, solid state type with indicator lamp DC4~28V
ZB430 — Two wire type, solid state type with indicator lamp DC10~28V
CS3H — Two wire type, reed switch type with indicator lamp DC10~30V AC85~115V
CS4H — Two wire type, reed switch type with indicator lamp DC10~30V AC85~115V
CS5H — Two wire type, reed switch type without indicator lamp DC3~30V AC85~115V
ZB333 — Two wire type, extra short solid state type with indicator lamp DC10~28V
ZB334 — Two wire type, short solid state type with indicator lamp DC10~28V
ZB131 — Two wire type, solid state type with two color lights DC10~28V
ZB132 — Two wire type, solid state type with two color lights DC10~28V

● See page 616 for sensor switch specifications

Note 1: Standard cylinders have a built-in magnet

2: Non-ion specification is custom order. But non-ion specification is not available for ø32.

Consult us on specifications and delivery time.

Inner Construction and Major Parts

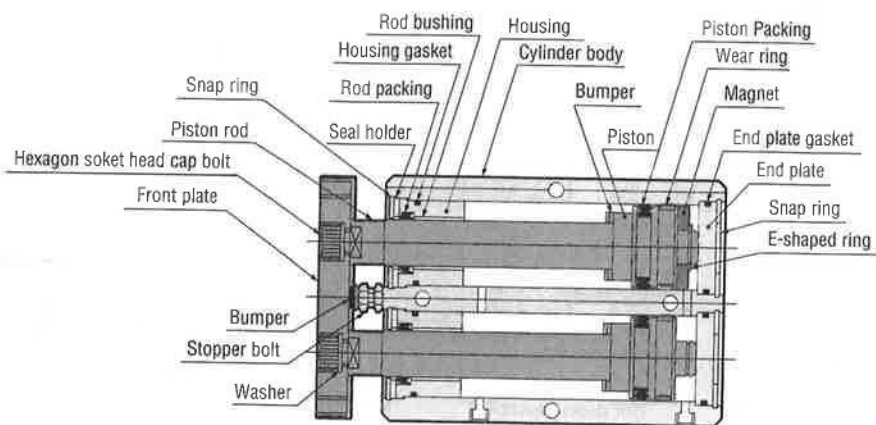

Material of Major Parts

Item	Material	
	Standard specification	Non-ion specification (-NCU)
Cylinder body	Aluminium alloy	←
Piston	Aluminium alloy	←
Wear ring	Resin	Resin (non-teflon)
Piston rod	Hard steel (chrome plated)	←
Gasket	Synthetic rubber (NBR)	←
Seal holder	Mild steel (Nickel plated)	←
Housing	Aluminium alloy	←
End plate	Aluminium alloy	←
Rod bushing	Oil permeated bronze	Resin (non-teflon)
Packing	Synthetic rubber (NBR)	←
Snap ring	Hard steel (Nickle plated)	←
Magnet	Resinous magnet	←
E-shaped ring	Stainless steel	←
Washer	Hard steel (black galvanized)	←
Front plate	Mild steel (black galvanized)	←
Bumper ^{Note 1}	Synthetic rubber (NBR)	←
Stopper bolt	Mild steel (galvanized)	←

Note 1: Not available for ø10mm cylinders.
Remark: Non-ion specification is made to order.

Packing List

Item	Rod packing	Piston packing	End plate gasket	Housing gasket
10	PIU-6	PWP-10	1.5×9	1.5×9
16	PIU-8	PWP-16	1.5×14.5	1.5×13
20	PIU-10	PWP-20	1.5×18	1.5×17
25	PIU-12	PWP-25	1.5×23	1.5×22
32	PIU-16	PWP-32	2×31.5	2×28.5

Weight

Cylinder bore size (mm)	Standard specification	Zero stroke weight ^{Note 1}	Added weight			
			Added weight per 10mm stroke	Weight of one sensor switch ^{Note 2}		
				CS9H□ · ZB430□	CS3H□	CS4H□
10	Standard specification	100	18	30	20	40
	Non-ion specification	100				
16	Standard specification	206	27			
	Non-ion specification	204				
20	Standard specification	335	36			
	Non-ion specification	329				
25	Standard specification	495	51			
	Non-ion specification	489				
32	Standard specification	1230	88			

Note 1: Above chart is for standard stroke cylinders.

Note 2: Lead wires for sensor switches have two lengths.

A: 1000mm, B: 3000mm

Above chart is for A-type lead length.

Calculation example: The weight of a standard specification cylinder with 20mm bore size and 60mm stroke with two sensor switches is

$$335 + (36 \times 6) + (20 \times 2) = 591 \text{ g}$$

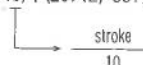

Dimensions of Double Acting Type (1/2 scale, Unit mm)

● Please see page 317 for detailed dimensions of the rod end.

● $\phi 10$

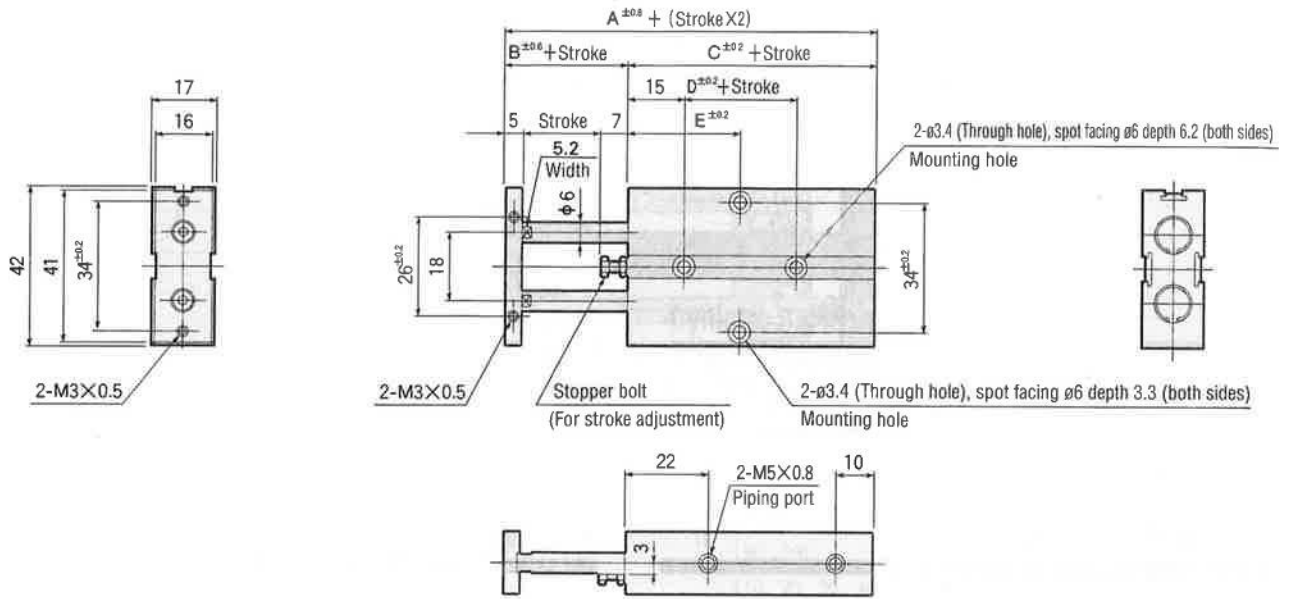

Stroke mm	Symbol	A	B	C	D	E						
						10	20	30	40	50	60	70
10		58	12	46	10	30	30	35	40	45	50	55

Discontinued

Dimensions of Double Acting Type (1/2 scale, Unit mm)

● Please see page 317 for detailed dimensions of the rod end.

● $\phi 16 \sim \phi 25$

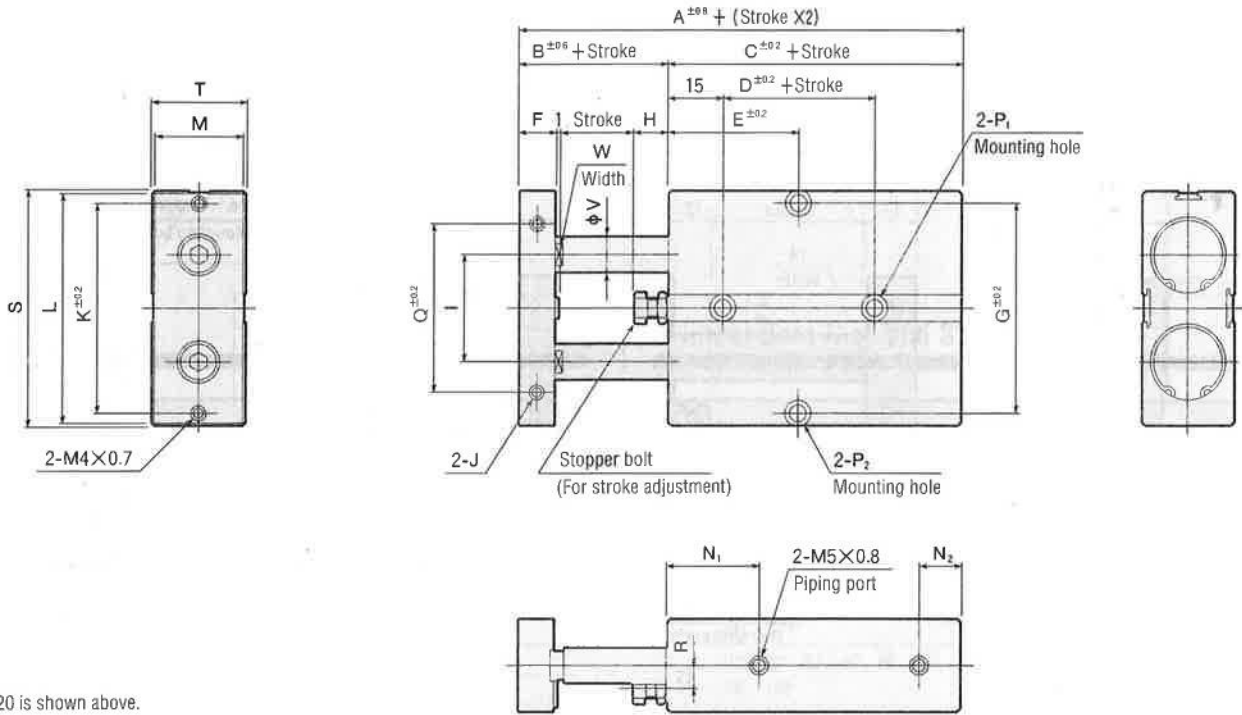

Note: $\phi 20$ is shown above.

Stroke	Symbol	A	B	C	D	E										F	G	H	I	J	K	L	M	N ₁	N ₂
						10	20	30	40	50	60	70	80	90	100										
16		68	15	53	20	30	35	40	45	50	55	60	65	70	75	8	47	6	24	M4×0.7 Depth 5	47	53	20	22	10
20		78	20	58	20	35	35	40	45	50	55	60	65	70	75	10	55	9	28	M4×0.7 Depth 5	55	61	24	25	12
25		81	19	62	30	40	40	45	50	55	60	65	70	75	80	10	66	8	34	M5×0.8 Depth 6	66	72	29	30	12

Bore size	Symbol	P ₁ Note		P ₂		Q	R	S	T	V	W
16		$\phi 4.5$ (through hole) spot facing $\phi 7.5$ depth 7.2 (both sides)		$\phi 4.5$ (through hole) spot facing $\phi 8$ depth 4.4 (both sides)		34	4	54	21	8	6.2
20		$\phi 4.5$ (through hole) spot facing $\phi 7.5$ depth 7.2 (both sides)		$\phi 4.5$ (through hole) spot facing $\phi 8$ depth 4.4 (both sides)		44	6	62	25	10	8.2
25		$\phi 4.5$ (through hole) spot facing $\phi 7.5$ depth 7.2 (both sides)		$\phi 4.5$ (through hole) spot facing $\phi 8$ depth 4.4 (both sides)		56	7	73	30	12	10.2

Note: Spot facing is measured from the outermost surface of cylinder

Dimensions of Double Acting Type (2/5 scale, Unit mm)

● $\phi 32$

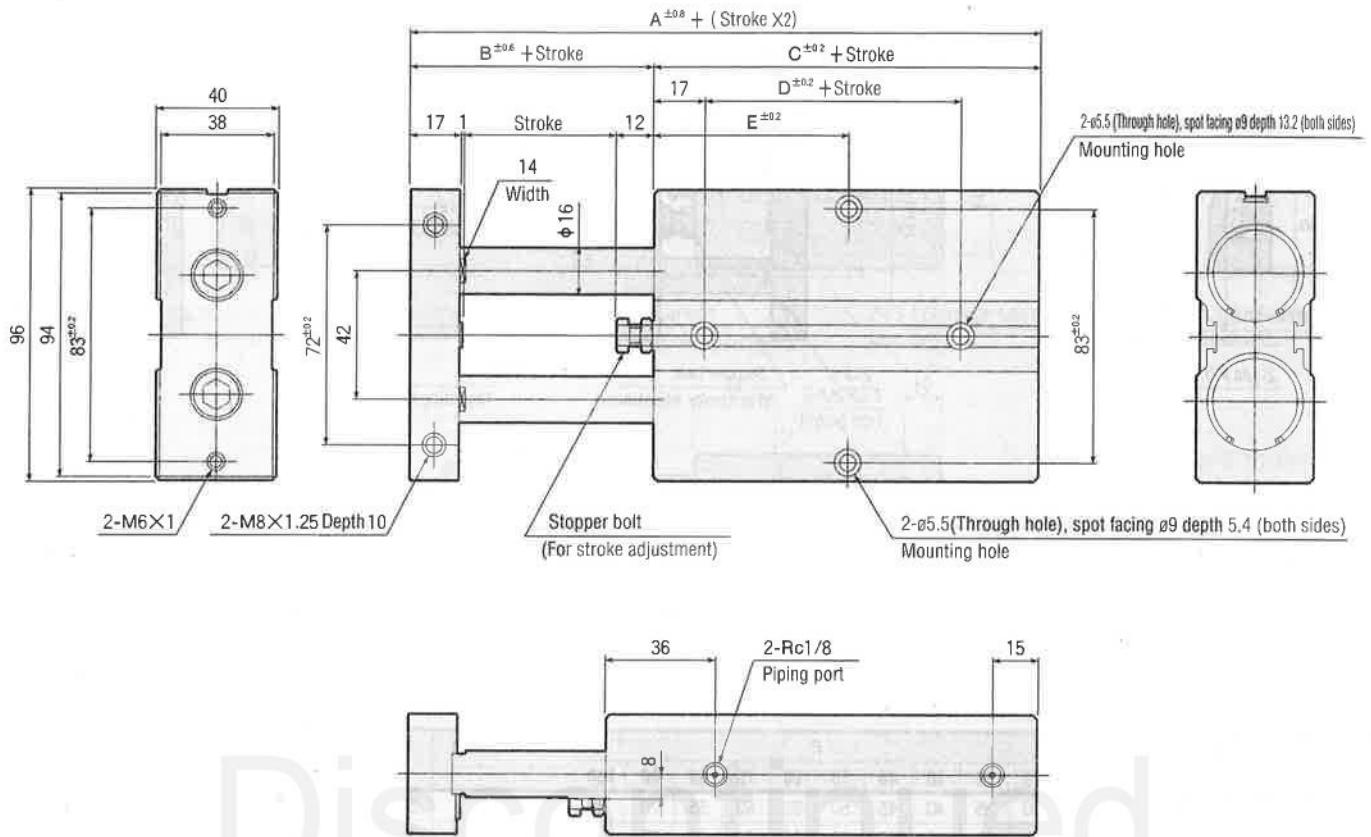

Stroke	Symbol	A	B	C	D	E										
						10	20	30	40	50	60	70	80	90	100	
32		108	30	78	35	45	50	55	60	65	70	75	80	85	90	

Note: Spot facing is measured from the outermost surface of cylinder

Dimensions of the Rod End (Unit mm)

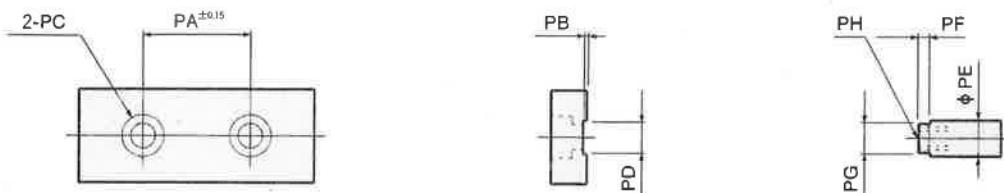

Bore size	Symbol	PA	PB	PC		PD	PE	PF	PG	PH	
10		18	0.5	$\phi 3.3$	spot facing $\phi 6.2$ depth 3.5	$5.2^{+0.1}_0$	6	3	$5.2^{+0.05}_{-0.15}$	M3 X0.5	depth 5
18		24	1	$\phi 4.3$	spot facing $\phi 7.8$ depth 4.6	$6.2^{+0.1}_0$	8	3	$6.2^{+0.05}_{-0.15}$	M4 X0.7	depth 6
20		28	1	$\phi 6.5$	spot facing $\phi 11$ depth 6.8	$8.2^{+0.1}_0$	10	3	$8.2^{+0.05}_{-0.15}$	M6 X1	depth 8
25		34	1	$\phi 6.5$	spot facing $\phi 11$ depth 6.8	$10.2^{+0.1}_0$	12	3	$10.2^{+0.05}_{-0.15}$	M6 X1	depth 8
32		42	2	$\phi 10.6$	spot facing $\phi 17$ depth 12	$14^{+0.2}_{-0.03}$	16	4	$14^{+0.2}_{-0.2}$	M10 X1.5	depth 14

TWIN ROD CYLINDERS

Double Acting Long Bushing Type

Symbol

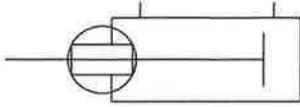

Specification

Item	Bore size (mm)	10	16	20	25	32
Operation		Double-acting type				
Fluid		Air				
Mounting type		Side mounting type				
Pressure range	MPa(kgf/cm ²)	0.2~0.7 {2~7.1}	0.15~0.7(1.5~7.1)			
Proof Pressure	MPa(kgf/cm ²)	1.03(10.5)				
Temperature	°C	0~60				
Piston speed range	mm/s	100~500				
Cushion		None	Rubber bumper			
Lubrication		Not required (if required, apply turbine oil class 1 (ISO VG32) or equivalent)				
Maximum rod rotation		±0.4°	±0.3°			
Stroke adjustment range	mm	-5~0 (per specific stroke)				
Port size		M5×0.8			Rc1/8	

Cylinder Bore Size and Stroke

Bore size	Standard stroke	Maximum stroke (available)	mm
			Pull stroke adjustment range
10	10, 20, 30, 40, 50, 60, 70	90	-5~0
18	10, 20, 30, 40, 50, 60, 70, 80, 90, 100	110	
20	10, 20, 30, 40, 50, 60, 70, 80, 90, 100	120	
25	10, 20, 30, 40, 50, 60, 70, 80, 90, 100	140	
32	10, 20, 30, 40, 50, 60, 70, 80	140	
	90, 100		

Note 1: Contact us if you need to attach two sensor switches on 10mm stroke cylinders.

Note 2: Please consult us for delivery time of cylinder with longer stroke than standard stroke.

Order Example

TDAM 16×30 — CS9H A 2

Cylinder bore size × Stroke

Sensor switch type

Lead wire length
A : 1000mm
B : 3000mm
(B is the only two-color luminous type sensor switch)

Number of sensor switch
1 — With one sensor switch
2 — With two sensor switches
(With one sensor switch only for ZB333,ZB334)

Twin rod cylinder
Double acting long bushing type

CS9H — Three wire type, solid state type with indicator lamp DC4~28V

ZB430 — Two wire type, solid state type with indicator lamp DC10~28V

CS3H — Two wire type, reed switch type with indicator lamp DC10~30V
AC85~115V

CS4H — Two wire type, reed switch type with indicator lamp DC10~30V
AC85~115V

CS5H — Two wire type, reed switch type without indicator lamp DC3~30V
AC85~115V

ZB333 — Two wire type, solid state extra short type with indicator lamp DC10~28V

ZB334 — Two wire type, solid state short type with indicator lamp DC10~28V

ZB131 — Two wire type, solid state type with two color lights DC10~28V

ZB132 — Two wire type, solid state type with two color lights DC10~28V

● See page 616 for sensor switch specifications

Note: Standard cylinders have a built-in sensor switch magnet.

Inner Construction and Major Parts

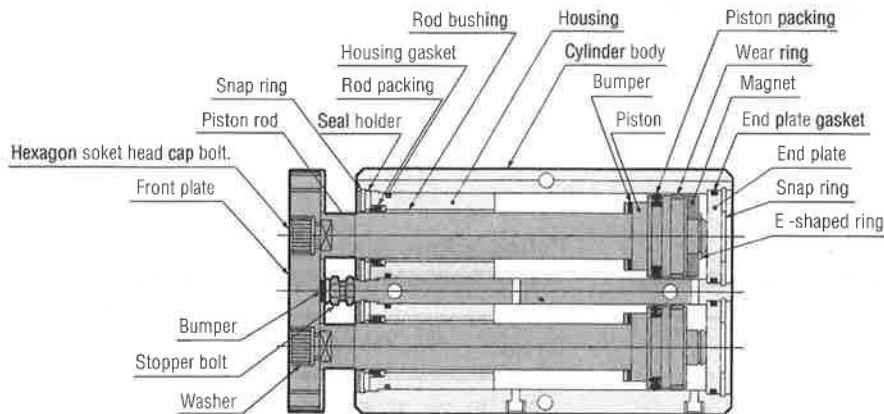

Material of Major Parts

Item	Material
Cylinder body	Aluminium alloy
Piston	Aluminium alloy
Wear ring	Resin (non-teflon)
Piston rod	Hard steel (chrome plated)
Gasket	Synthetic rubber (NBR)
Seal holder	Mild steel (Nickle plated)
Housing	Aluminium alloy
End plate	Aluminium alloy
Rod bushing	Oil permeated bronze,
Packing	Synthetic rubber (NBR)
Snap ring	Hard steel (Nickle plated)
Magnet	Resinous magnet
E-shaped ring	Stainless steel
Washer	Hard steel (black galvanized)
Front plate	Mild steel (black galvanized)
Bumper ^{Note 1}	Synthetic rubber (NBR)
Stopper bolt	Mild steel (galvanized)

Note 1 : Not available for ø10mm cylinders.

Packing List

Item	Rod packing	Piston packing	End plate gasket	Housing gasket
Number	2	2	2	2
10	PIU-6	PWP-10	1.5×9	1.5×9
16	PIU-8	PWP-16	1.5×14.5	1.5×13
20	PIU-10	PWP-20	1.5×18	1.5×17
25	PIU-12	PWP-25	1.5×23	1.5×22
32	PIU-16	PWP-32	2×31.5	2×28.5

Weight

Cylinder bore size (mm)	Zero stroke weight ^{Note 1}	Added weight per 10mm stroke	Added weight			
			Weight of one sensor switch ^{Note 2}			
			CS9H□ · ZB430□	CS3H□	CS4H□	CS5H□
10	119	18				
16	244	27				
20	388	36	30	20		40
25	568	51				
32	1354	88				

Note 1: Above chart is for standard stroke cylinders.

2: Lead wires for sensor switches have two lengths.

A : 1000mm, B : 3000mm

Weight shown is for A-type lead length

Calculation example : The weight of a 20mm bore cylinder with 60mm stroke with two CS3HA sensor switches is:

$$388 + (36 \times 6) + (20 \times 2) = 664g$$

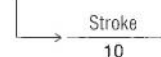

● $\phi 10$

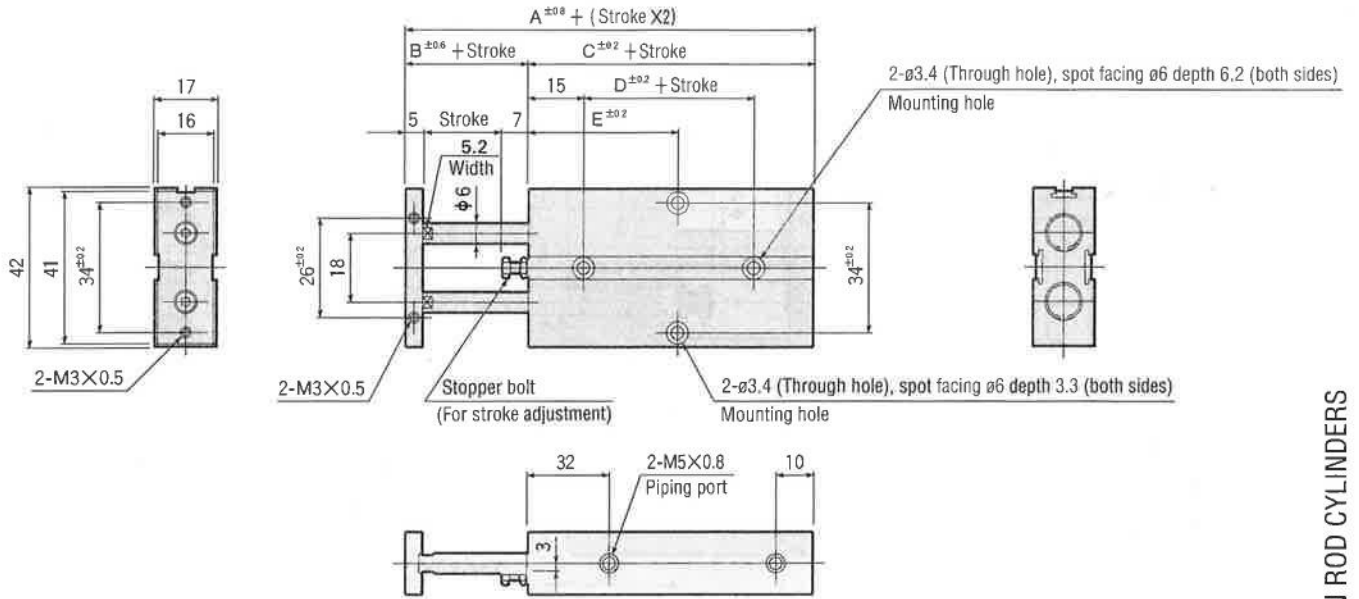

Stroke	Symbol	A	B	C	D	E						
						10	20	30	40	50	60	70
10		68	12	56	25	25	40	45	50	55	60	65

Discontinued

Dimensions of Double Acting Long Bushing Type (1/2 scale, Unit mm)

● See page 322 for detailed dimensions of the rod end.

● $\phi 16 \sim \phi 25$

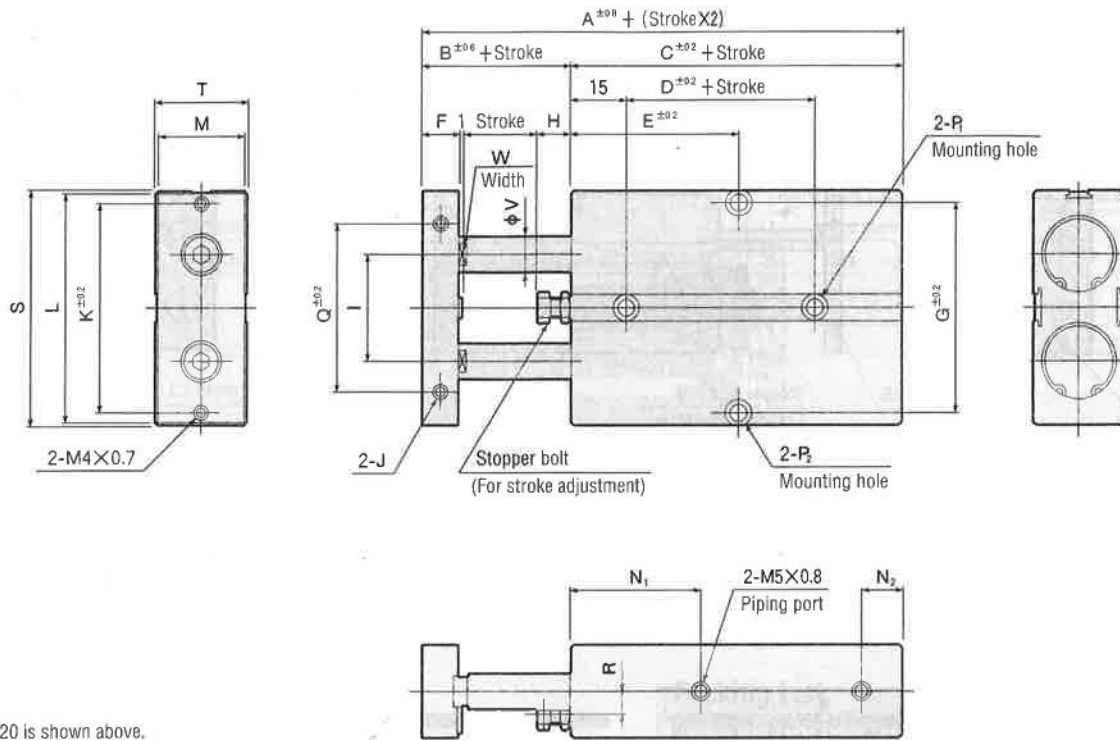

Note: $\phi 20$ is shown above.

Stroke	Symbol	A	B	C	D	E										F	G	H	I	J	K	L	M	N ₁	N ₂
						10	20	30	40	50	60	70	80	80	90										
16		78	15	63	30	40	45	50	55	60	65	70	75	80	85	8	47	6	24	M4X0.7 depth 5	47	53	20	32	10
20		88	20	68	30	45	45	45	50	55	60	65	70	75	80	10	55	9	28	M4X0.7 depth 5	55	61	24	35	12
25		91	19	72	40	50	50	50	55	60	65	70	75	80	85	10	66	8	34	M5X0.8 depth 6	66	72	29	40	12

Stroke	Symbol	P ₁ note		P ₂		Q	R	S	T	V	W
16		$\phi 4.5$ (through hole) spot facing $\phi 7.5$ depth 7.2 (both sides)		$\phi 4.5$ (through hole) spot facing $\phi 8$ depth 4.4 (both sides)		34	4	54	21	8	6.2
20		$\phi 4.5$ (through hole) spot facing $\phi 7.5$ depth 7.2 (both sides)		$\phi 4.5$ (through hole) spot facing $\phi 8$ depth 4.4 (both sides)		44	6	62	25	10	8.2
25		$\phi 4.5$ (through hole) spot facing $\phi 7.5$ depth 7.2 (both sides)		$\phi 4.5$ (through hole) spot facing $\phi 8$ depth 4.4 (both sides)		56	7	73	30	12	10.2

Note: Spot facing is measured from the outermost surface of cylinder

Dimensions of Double Acting Long Bushing Type (1/2 scale, Unit mm)

● $\phi 32$

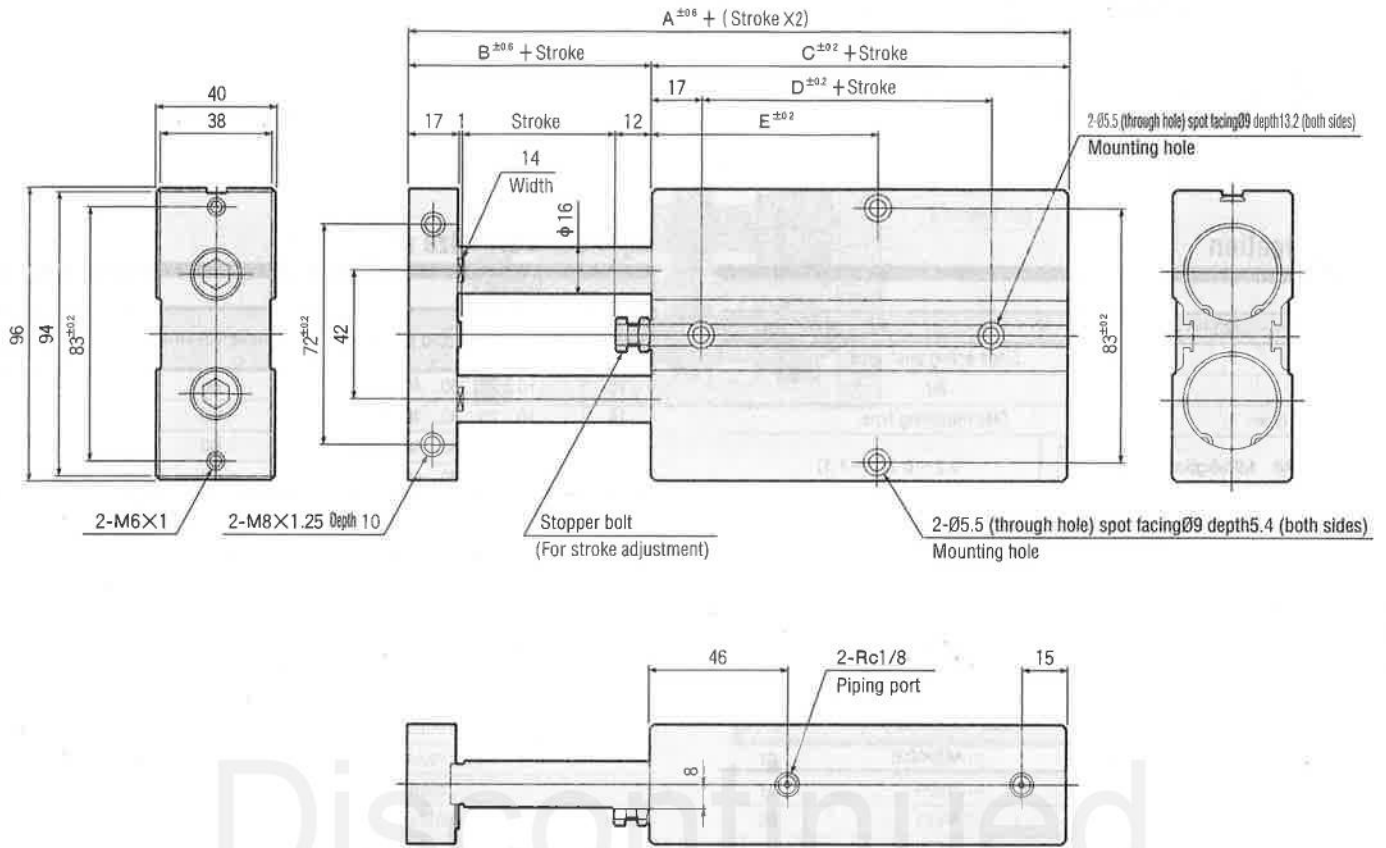

Stroke 32mm	Symbol	A	B	C	D	E									
						10	20	30	40	50	60	70	80	90	100
32		118	30	88	45	55	60	65	70	75	80	85	90	95	100

Note: Spot facing is measured from the outermost surface of cylinder.

Dimensions of Rod End (unit mm)

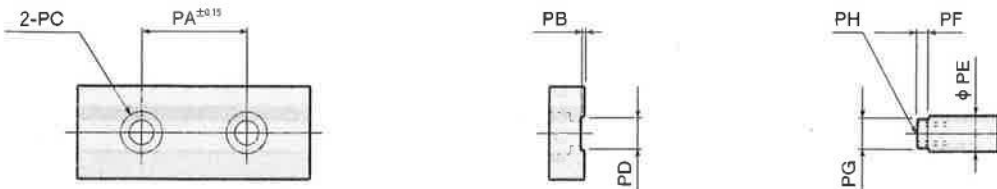

Bore size	Symbol	PA	PB	PC	PD	PE	PF	PG	PH
10		18	0.5	$\phi 3.3$ spot facing $\phi 6.2$ depth 3.5	$5.2^{+0.1}_0$	6	3	$5.2^{+0.05}_{-0.15}$	M3 $\times 0.5$ depth 5
16		24	1	$\phi 4.3$ spot facing $\phi 7.8$ depth 4.6	$6.2^{+0.1}_0$	8	3	$6.2^{+0.05}_{-0.15}$	M4 $\times 0.7$ depth 6
20		28	1	$\phi 6.5$ spot facing $\phi 11$ depth 6.8	$8.2^{+0.1}_0$	10	3	$8.2^{+0.05}_{-0.15}$	M6 $\times 1$ depth 8
25		34	1	$\phi 6.5$ spot facing $\phi 11$ depth 6.8	$10.2^{+0.1}_0$	12	3	$10.2^{+0.05}_{-0.15}$	M6 $\times 1$ depth 8
32		42	2	$\phi 10.6$ spot facing $\phi 17$ depth 12	$14^{+0.2}_{+0.05}$	16	4	$14^{+0.2}_{-0.2}$	M10 $\times 1.5$ depth 14

Twin Rod Cylinders

Single Acting Push Type

Symbol

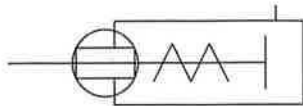

Specification

Item	Bore size (mm)	10	16	20	25
Operation		Single acting push type			
Fluid		Air			
Mounting type		Side mounting type			
Pressure range	MPa(kgf/cm ²)	0.25~0.7 {2.5~7.1}	0.2~0.7{2~7.1}		
Proof pressure	MPa(kgf/cm ²)	1.03{10.5}			
Temperature	°C	0~60			
Piston speed range	mm/s	100~500			
Cushion		None	Rubber bumper		
Lubrication		Not required (if used, apply turbine oil class 1 (ISO VG32) or equivalent)			
non-rotate accuracy		±0.4°	±0.3°		
Stroke adjustment range	mm	-5~0 (per specific stroke)			
Port size		M5×0.8			

Cylinder Bore Size and Stroke

Bore size	Standard stroke	Maximum stroke	Pull side stroke adjustment range
10	10, 20, 30, 40, 50, 60	60	-5~0
18	10, 20, 30, 40, 50, 60	60	
20	10, 20, 30, 40, 50, 60	60	
25	10, 20, 30, 40, 50, 60	60	

Note: Contact us if you need to attach two sensor switches on the 10mm stroke sensor cylinders.

Discontinued

Order Example

TSA 16×30 - CS9H A 2

Twin rod cylinders
Single acting push type ^{note 1}

Bore size
x
Stroke

Sensor switch type

CS9H	Three wire type, Solid state type with indicator lamp	DC4~28V
ZB430	Two wire type, Solid state type with indicator lamp	DC10~28V
CS3H	Two wire type, Reed switch type with indicator lamp	DC10~30V AC85~115V
CS4H	Two wire type, Reed switch type with indicator lamp	DC10~30V AC85~115V
CS5H	Two wire type, Reed switch type without indicator lamp	DC3~30V AC85~115V
ZB333	Two wire type, Solid state extra short type with indicator lamp	DC10~28V
ZB334	Two wire type, Solid state short type with indicator lamp	DC10~28V
ZB131	Two wire type, Solid state type with two colors indicator lamp	DC10~28V
ZB132	Two wire type, Solid state type with two colors indicator lamp	DC10~28V

● See page 616 for sensor switch specifications.

Lead wire length

A : 1000mm

B : 3000mm

(B is the only two-color luminous type sensor switch)

Number of sensor switches

1 - With one sensor switch

2 - With two sensor switches

(With one switch only, for ZB333 and ZB334)

Note: Standard cylinders have a magnet for sensor switch.

Inner Construction and Major Parts

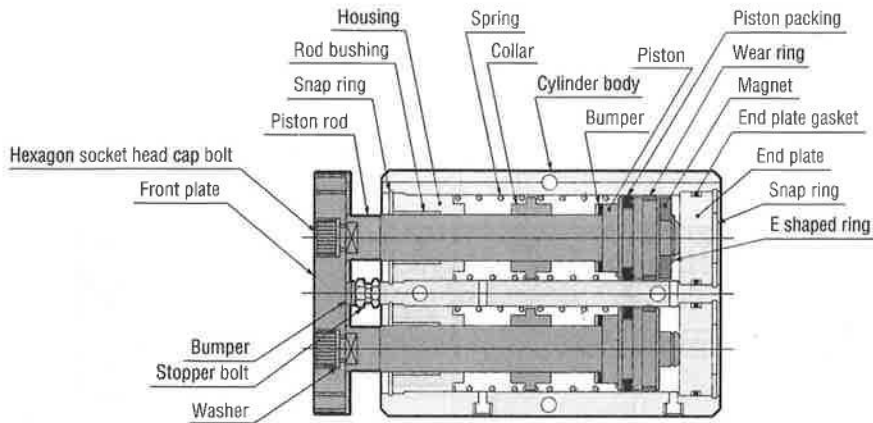

Material of Major Parts

Item	Material
Cylinder body	Aluminium alloy
Piston	Aluminium alloy
Wear ring	Resin
Piston rod	Hard steel (chrome plated)
Gasket	Synthetic rubber (NBR)
Seal holder	Mild steel (Nickle plated)
Housing	Aluminium alloy
End plate	Aluminium alloy
Rod bushing	Oil permeated bronze
Packing	Synthetic rubber (NBR)
Snap ring	Hard steel (Nickle plated)
Magnet	Resinous magnet
Spring	Piano wire
E shaped ring	Stainless steel
Washer]	Hard steel (Black galvanized)
Square plate	Mild steel (Black galvanized)
Bumper ^{note 1}	Synthetic rubber (NBR)
Stopper bolt	Mild steel (Galvanized)

Note: Not available for 10mm bore cylinders

Packing List

Item	Piston packing	End plate gasket
	2	1
10	PWP-10	1.5×9
18	PWP-16	1.5×14.5
20	PWP-20	1.5×18
25	PWP-25	1.5×23

Weight

Cylinder Bore size (mm)	Basic weight						Added weight;				
	Stroke (mm)						Weight of one sensor switch ^{note 2}				
	10	20	30	40	50	60	CS9H□ · ZB430□	CS3H□	CS4H□	CS5H□	ZB13□□ · ZB33□□
10	117	137	157	197	217	237	30	20			40
16	230	257	288	344	369	394					
20	372	407	442	521	556	591					
25	557	603	649	760	814	868					

Note 1: The chart are for standard stroke cylinders.

2: Lead wire length has two types:

A: 1000mm, B: 3000mm

Weight shown is for A-type lead length.

Calculation example: The weight of a 20mm bore standard sensor cylinder with a 40mm stroke, together with two (CS3HA) sensor switches is

$$521 + (20 \times 2) = 581 \text{g}$$

Dimensions of Single Acting Push Type (1/2 scale, unit mm)

See page 325 for rod end dimensions.

● $\phi 16 \sim \phi 25$

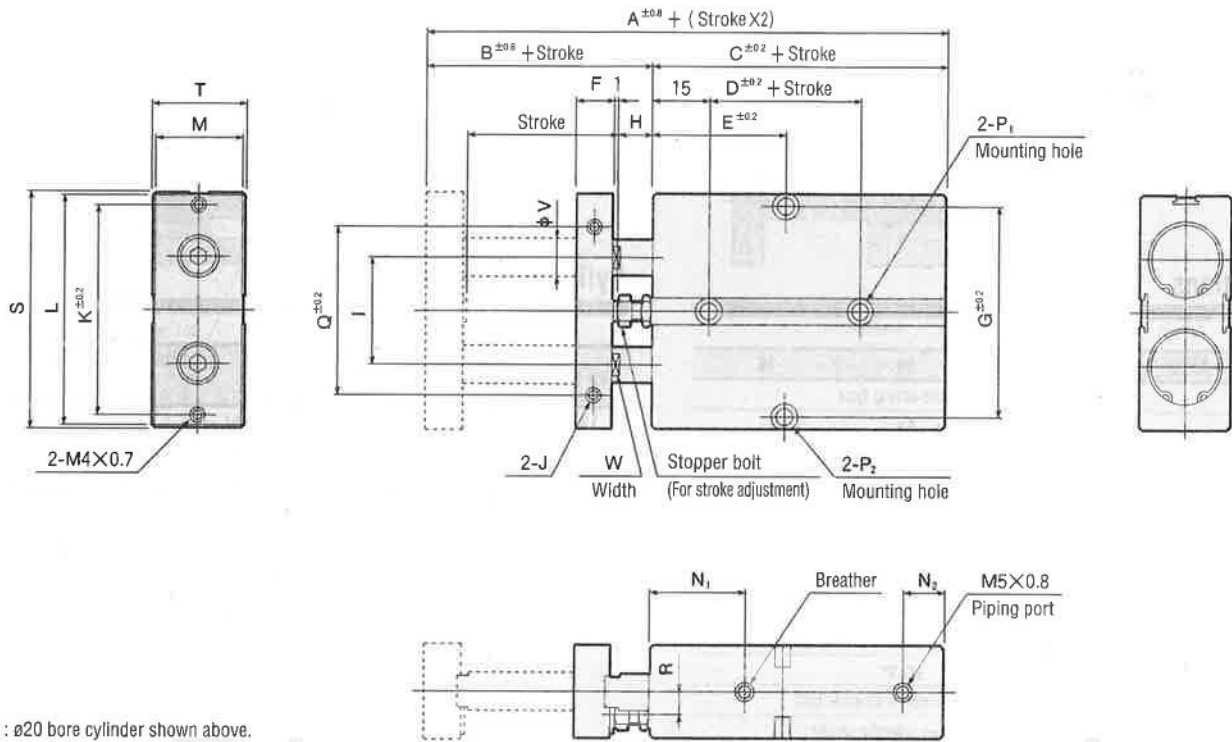

Note : $\phi 20$ bore cylinder shown above.

Discontinued

Stroke	Symbol	A		B	C		D		E				F	G	H	I	J		
		10~30	40~80		10~30	40~80	10~30	40~80	10	20	30	40						50	80
16		68	78	15	53	63	20	30	30	35	40	50	55	60	8	47	6	24	M4x0.7 Depth 5
20		78	88	20	58	68	20	30	35	35	40	50	55	60	10	55	9	28	M4x0.7 Depth 5
25		81	91	19	62	72	30	40	40	40	45	55	60	65	10	66	8	34	M5x0.8 Depth 6

Bore size	Symbol	K	L	M	N ₁	N ₂	P ₁ Note		P ₂				Q	R	S	T	V	W
							$\phi 4.5$ (Through hole)	spot facing $\phi 7.5$ depth7.2(both sides)	$\phi 4.5$ (Through hole)	spot facing $\phi 8$ depth4.4(both sides)	$\phi 4.5$ (Through hole)	spot facing $\phi 8$ depth4.4(both sides)						
18		47	53	20	22	10	$\phi 4.5$ (Through hole)	spot facing $\phi 7.5$ depth7.2(both sides)	$\phi 4.5$ (Through hole)	spot facing $\phi 8$ depth4.4(both sides)	$\phi 4.5$ (Through hole)	spot facing $\phi 8$ depth4.4(both sides)	34	4	54	21	8	6.2
20		55	61	24	25	12	$\phi 4.5$ (Through hole)	spot facing $\phi 7.5$ depth7.2(both sides)	$\phi 4.5$ (Through hole)	spot facing $\phi 8$ depth4.4(both sides)	$\phi 4.5$ (Through hole)	spot facing $\phi 8$ depth4.4(both sides)	44	6	62	25	10	8.2
25		66	72	29	30	12	$\phi 4.5$ (Through hole)	spot facing $\phi 7.5$ depth7.2(both sides)	$\phi 4.5$ (Through hole)	spot facing $\phi 8$ depth4.4(both sides)	$\phi 4.5$ (Through hole)	spot facing $\phi 8$ depth4.4(both sides)	56	7	73	30	12	10.2

Note: Spot facing is measured from the outer surface of the cylinder

Twin Rod End Keep Cylinders

Double Acting type

Symbols

● Head side end kept

● Rod side end kept

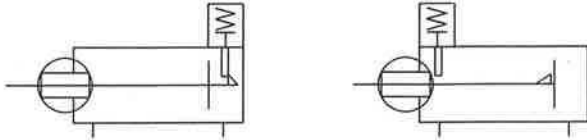

Specifications

Item	Cylinder bore size (mm)		
	16	20	25
Operation	Double acting type		
Fluid	Air		
Mounting type	Side mounting type		
Pressure range MPa(kgf/cm ²)	0.15~0.7(1.5~7.1)		
Proof pressure MPa(kgf/cm ²)	1.03(10.5)		
Temperature range °C	0~60		
Speed range mm/s	100~500		
Cushion	Rubber bumper		
Lubrication	Not required (if lubrication is used, apply Class 1 turbine oil (ISO VG321) or equivalent.)		
non-rotate accuracy	±0.3°		
Stroke adjustment range mm	Fixed type with a stopper bolt -5 ~ 0 (per specific stroke)		
Maximum retaining force (during end kept operation) N	96.1	151	235.4
Backlash (during end kept operation) mm	1MAX.		
Port size	M5×0.8		

Cylinder Bore Size and Stroke

Bore size	Standard stroke	Pull side stroke adjustment mm	
		-HL	-RL
18	10, 20, 30, 40, 50, 60, 70, 80	—	-5~0
20	10, 20, 30, 40, 50, 60, 70, 80		
25	10, 20, 30, 40, 50, 60, 70, 80		

Note: Consult us when using two sensor switches on cylinders with 10mm stroke.

Order Example

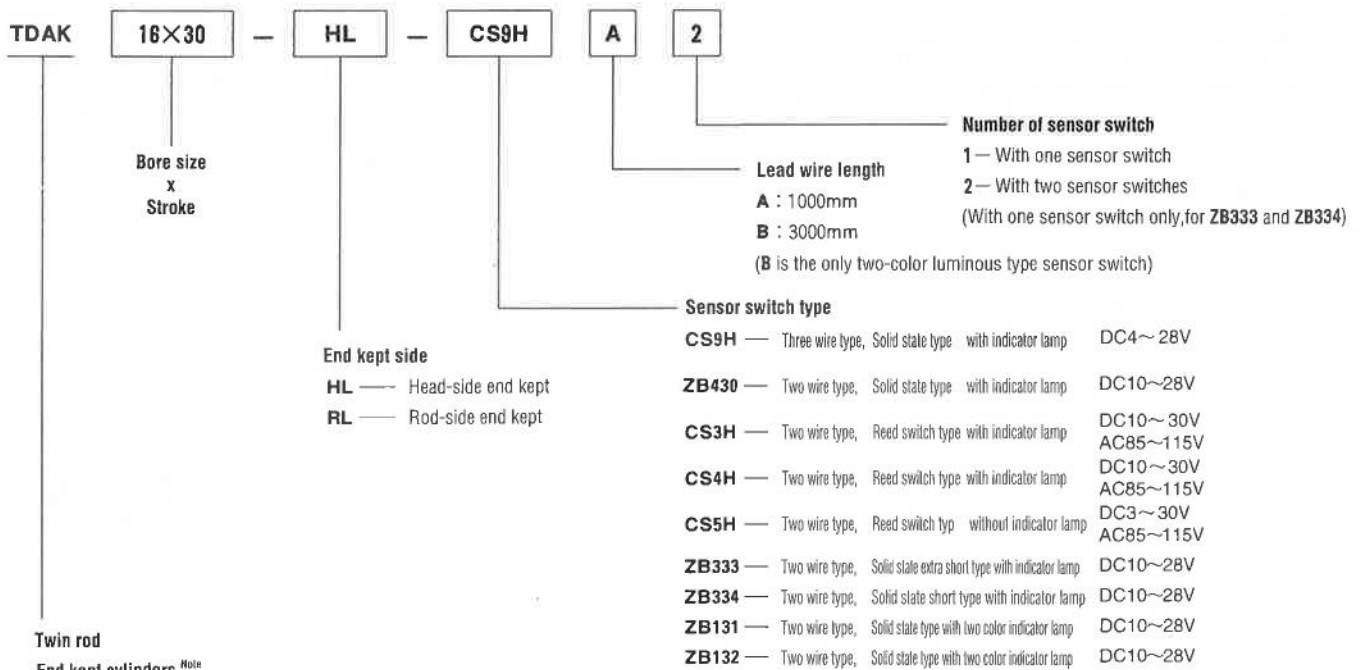

Note: Standard cylinders have a magnet for sensor switch.

Inner Construction and Major Parts

●-HL : Head-side end kept

●-RL : Rod-side end kept

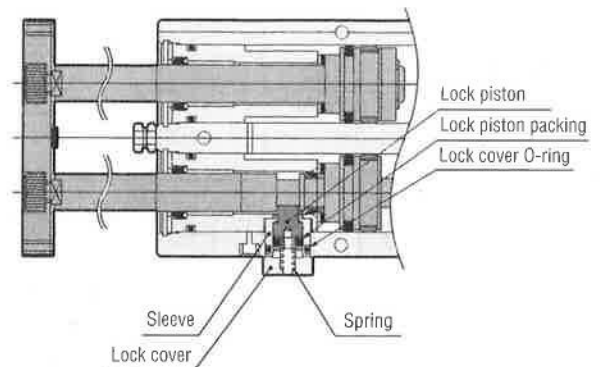
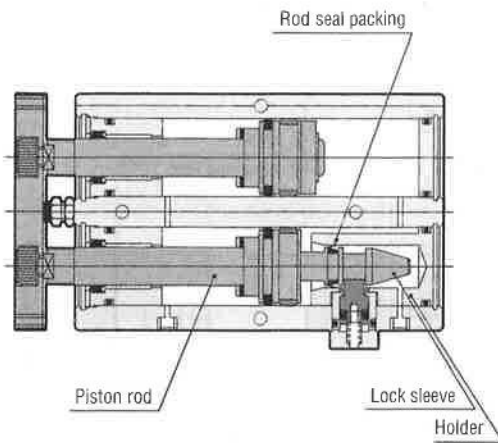

Material and Major Parts

Item		Material
Piston rod	-HL	Hard steel (chrome plated)
	-RL	Hard steel (heat treated chrome plated)
Lock sleeve (-HL only)		Hard steel (heat treated)
Holder (-HL only)		Aluminum alloy
Lock piston		Hard steel (heat treated)
Sleeve		Aluminum alloy
Spring		Stainless steel
Lock cover		Aluminum alloy
Lock piston packing		Synthetic rubber
Rod seal packing		Synthetic rubber
Lock cover O-ring		Synthetic rubber

Note: Please see page 314 for materials not listed above.

Packing List

Bore size (mm)	Item Number	Rod packing	Piston packing	End plate gasket	Rod seal packing	Housing gasket	Rod piston packing
		2	2	2	1	2	1
18		PIU-8	PWP-16	1.5×14.5	MYN-6	1.5×13	MYN-5
20		PIU-10	PWP-20	1.5×18	MYN-8	1.5×17	MYN-5
25		PIU-12	PWP-25	1.5×23	MYN-10	1.5×22	MYN-5

Weight

Cylinder bore size (mm)		Zero stroke weight ^{Note 1}	Added weight per 10mm stroke	Added weight				
				Weight of one sensor switch ^{Note 2}				
				CS9H □ · ZB430 □	CS3H □	CS4H □	CS5H □	ZB13 □ □ · ZB33 □ □
16	-HL : Head-side end kept	233	35	30	20	40		
	-RL : Rod-side end kept	258	33					
20	-HL : Head-side end kept	365	50					
	-RL : Rod-side end kept	384	49					
25	-HL : Head-side end kept	633	52					
	-RL : Rod-side end kept	661	51					

Note 1: The chart is for standard stroke cylinder.

Note 2: Lead wire length has two types:

A: 1000mm; B: 3000mm

Above sensor switch weights are for A-type lead length.

Calculation example: The weight of a 20mm bore head side end keep cylinder with a 60 mm stroke, together with two CS3HA sensor switches is

$$315 + (50 \times 6) + (30 \times 2) = 675g$$

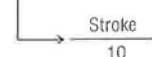

-HL: Dimensions of Head-Side End Keep Cylinder (1/2 scale, unit mm)

● See page 325 for rod end dimensions.

● $\phi 16 \sim \phi 25$

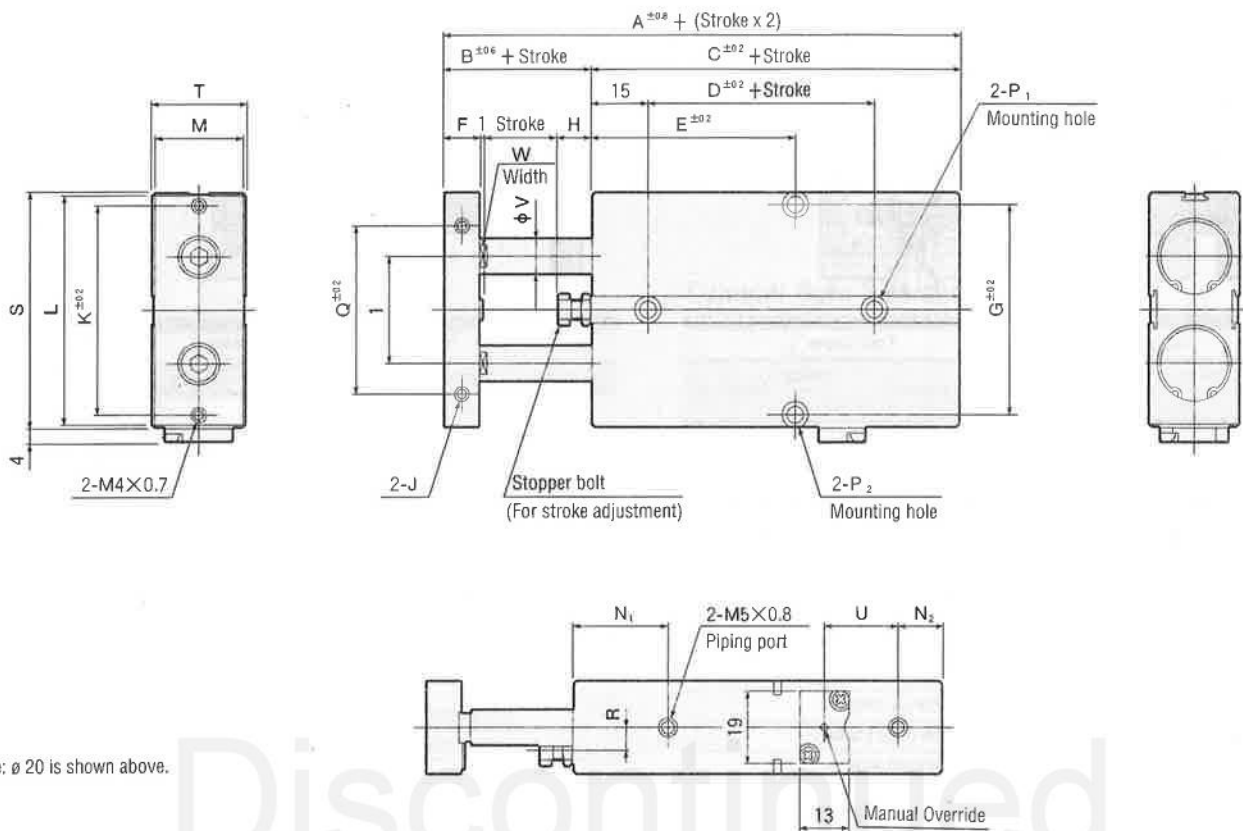

Note: $\phi 20$ is shown above.

Stroke	Symbol	A	B	C	D	E								F	G	H	I	J	K	L	M	N ₁	N ₂
						10	20	30	40	50	60	70	80										
16		88	15	73	40	40	45	50	55	60	65	70	75	8	47	6	24	M4x0.7 Depth 5	47	53	20	22	10
20		98	20	78	40	40	45	50	55	60	65	70	75	10	55	9	28	M4x0.7 Depth 5	55	61	24	25	12
25		101	19	82	50	45	50	55	60	65	70	75	80	10	66	8	34	M5x0.8 Depth 6	66	72	29	30	12

Bore size	Symbol	P ₁ Note				P ₂				Q	R	S	T	U	V	W
		1	2	3	4	1	2	3	4							
16		Ø4.5(Through hole)	Spot facing Ø7.5	Depth7.2	(Both sides)	Ø4.5(Through hole)	Spot facing Ø8	Depth4.4	(Both sides)	34	4	54	21	13	8	6.2
20		Ø4.5(Through hole)	Spot facing Ø7.5	Depth7.2	(Both sides)	Ø4.5(Through hole)	Spot facing Ø8	Depth4.4	(Both sides)	44	6	62	25	13	10	8.2
25		Ø4.5(Through hole)	Spot facing Ø7.5	Depth7.2	(Both sides)	Ø4.5(Through hole)	Spot facing Ø8	Depth4.4	(Both sides)	56	7	73	30	10	12	10.2

Note: Spot facing is measured from outermost surface of cylinder

-RL: Dimensions of Rod-Side End Kept Cylinder (1/2 scale, unit mm)

● See page 317 for rod end dimensions.

● $\phi 16 \sim \phi 25$

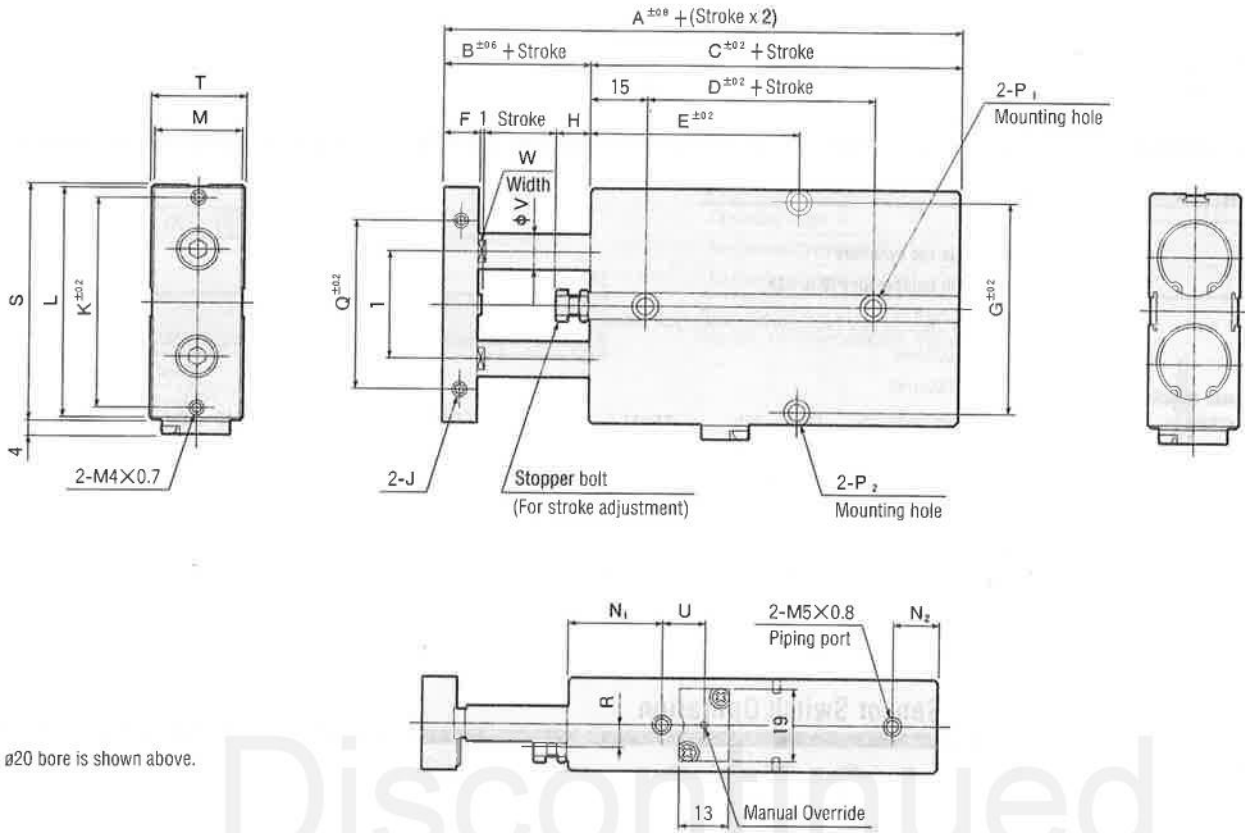

Note: $\phi 20$ bore is shown above.

Stroke	Symbol	A	B	C	D	E								F	G	H	I	J	K	L	M	N ₁	N ₂	
						10	20	30	40	50	60	65	70											80
16		88	15	73	40	45	45	50	55	60	65	70	75	8	47	6	24	M4x0.7	Depth 5	47	53	20	22	10
20		98	20	78	40	45	45	50	55	60	65	70	75	10	55	9	28	M4x0.7	Depth 5	55	61	24	25	12
25		101	19	82	50	50	50	55	60	65	70	75	80	10	66	8	34	M5x0.8	Depth 6	66	72	29	30	12

Bore size	Symbol	P _{1 bore}				P ₂				Q	R	S	T	U	V	W
		Through hole	Spot facing	Spot facing	Depth	Through hole	Spot facing	Spot facing	Depth							
16		$\phi 4.5$	(Through hole)	$\phi 7.5$	Depth 7.2	$\phi 4.5$	(Through hole)	$\phi 8$	Depth 4.4	34	4	54	21	11	8	6.2
20		$\phi 4.5$	(Through hole)	$\phi 7.5$	Depth 7.2	$\phi 4.5$	(Through hole)	$\phi 8$	Depth 4.4	44	6	62	25	11	10	8.2
25		$\phi 4.5$	(Through hole)	$\phi 7.5$	Depth 7.2	$\phi 4.5$	(Through hole)	$\phi 8$	Depth 4.4	56	7	73	30	9	12	10.2

Note: Spot facing is measured from outermost surface of cylinder

TWIN ROD CYLINDERS

Sensor Switches (general types)

Solid State Type • Reed Switch Type

Order Example (sensor switches only)

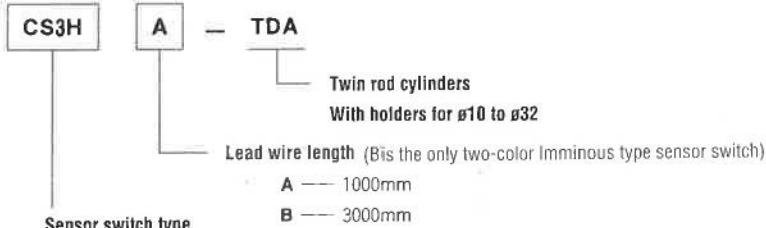

Sensor switch type

- | | | | |
|--|-----------------------|---|----------|
| CS9H — Three wire type, Solid state type with indicator lamp | DC4~28V | ZB131 — Two wire type, Solid state type with two color light | DC10~28V |
| ZB430 — Two wire type, Solid state type with indicator lamp | DC10~28V | ZB132 — Two wire type, Solid state type with two color light | DC10~28V |
| CS3H — Two wire type, Reed switch type with indicator lamp | DC10~30V
AC85~115V | | |
| CS4H — Two wire type, Reed switch type with indicator lamp | DC10~30V
AC85~115V | | |
| CS5H — Two wire type, Reed switch type without indicator lamp | DC3~30V
AC85~115V | | |

Minimum Stroke Necessary for Sensor Switch Operation

Sensor switch type	Cylinders with two switches		Cylinders with one switch
	One mounting side	Two mounting side	
CS□H□ · ZB430□	20	10	10
ZB131□ · ZB132□	40	10	10

● Cylinders with two switches

● Mounting two switches on one side

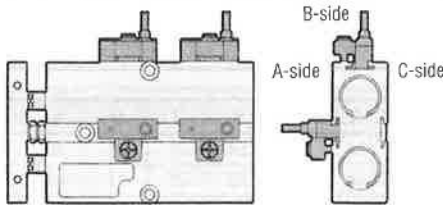

● Mounting two switches on two side

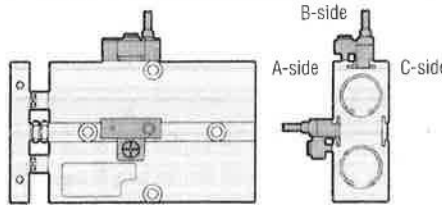

● Cylinders with one switch

● Mounting one switch on one side

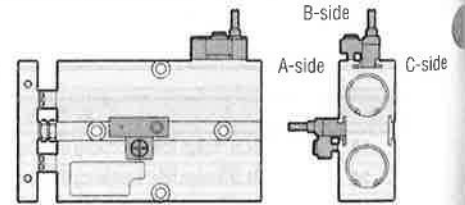

Sensor Switch Operating Range/Response Differential/Maximum Sensing Location

ZB13□ model (Two color LED sensor switch)

● Operating range

The range between the point where the switch turns ON and the point where it turns OFF after the piston moves further in the same direction.

● Setting range

This refers to the range where the green LED is ON in the operating range.

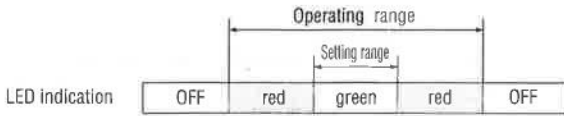

Cylinder bore size	ZB131□、ZB132□			mm
	Operating range	setting range*	Maximum sensing location	
10	5~8	4	8	
18	5~8.5	4		
20	5~9.5	4.5		
25	6~11	5		
32	7~12.5	7		

Note: The maximum sensing location is measured from lead wire end of switch.

Note 1: The chart indicates reference values.

Note 2: * indicate TYP (standard value).

Maximum sensing location determining procedure

● Setting head-side stroke end.

1. Push the piston up to the head side stroke end.
2. Move the temporarily installed sensor switch, until the indicator lamp is turned on green; fix it by tightening set screws within the range while the green LED is on.

● Setting rod-side stroke end.

1. Push the piston up to the rod-side stroke end.
2. Move the temporarily installed sensor switch until the indicator LED is turned on green; fix it by tightening set screws within the range while the green LED is on.

CS□H • ZB430 type

● Operating range: ℓ

The range between the point where the switch turns ON and the point where it turns OFF after the piston moves further in the same direction.

● Response differential: C

The distance between the point where the switch turns ON in one direction, and the point where the switch turns OFF as the piston travels in the opposite direction.

Item	Type	Solid state type	Reed switch type	mm
Operating range: ℓ		5TYP.(25°C)	7~12	
Response differential: C		1MAX.(25°C)	2	
Maximum sensing location ^{mm}			8	

Note: The value is measured from lead wire end of switch.

Remark: The chart indicates reference values.

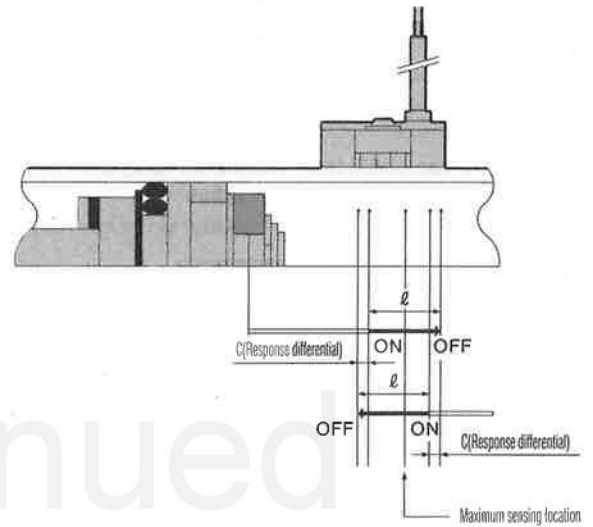

Positioning Sensor Switch Procedure

- Sensor switch can easily be slid along groove on cylinder body by loosening the mounting screw.
- Maximum torque for tightening mounting screw is 0.2N cm (2kgf-cm).
- Location of sensor switch in mounting groove should be as shown in the drawing.

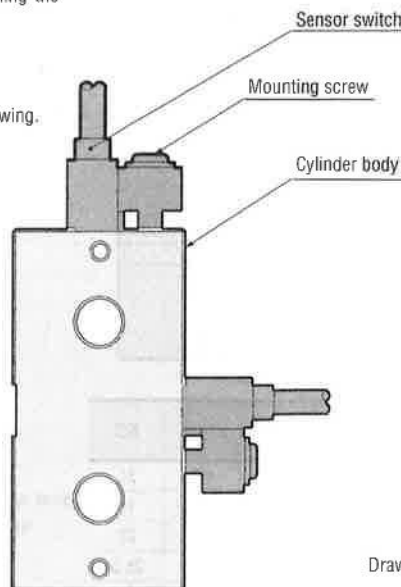

Drawing is shown from front plate.

Sensor Switch Mounting Locations for End of Stroke Positioning

By mounting sensor switches as shown below (the figures in the chart are reference values), the sensor magnet will be in the maximum sensing location at the end of the cylinder stroke.

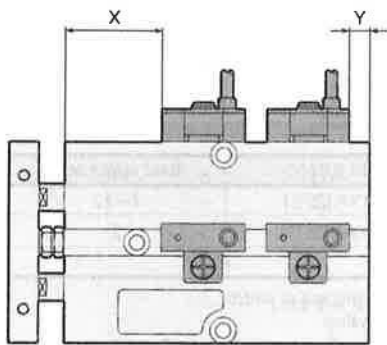

● Double acting type (TDA) mm

Cylinder bore size	Sensor switch type			
	CS□H□		ZB□□	
	X	Y	X	Y
10	19.5	4.5	7.5	4.5
18	25.5	5.5	13.5	5.5
20	29.5	6.5	17.5	6.5
25	34.5	5.5	22.5	5.5
32	44.0	12.0	32.0	12.0

Remark: Same values for Non-ion specification.

● Double acting long bushing type (TDAM) mm

Cylinder bore size	Sensor switch type			
	CS□H□		ZB□□	
	X	Y	X	Y
10	29.5	4.5	17.5	4.5
18	35.5	5.5	23.5	5.5
20	39.5	6.5	27.5	6.5
25	44.5	5.5	32.5	5.5
32	54.0	12.0	42.0	12.0

● Single acting push type (TSA) mm

Cylinder bore size	Sensor switch type							
	CS□H□				ZB□□			
	X		Y		X		Y	
	10 · 20 30	40 · 50 60	10 · 20 30	40 · 50 60	10 · 20 30	40 · 50 60	10 · 20 30	40 · 50 60
10	19.5	31.5	4.5	2.5	7.5	19.5	4.5	2.5
18	25.5	35.5	5.5	5.5	13.5	23.5	5.5	5.5
20	29.5	39.5	6.5	6.5	17.5	27.5	6.5	6.5
25	34.5	44.5	5.5	5.5	22.5	32.5	5.5	5.5

● End kept cylinders (TDAK) mm

Cylinder bore size	Sensor switch type							
	CS□H□				ZB□□			
	-HL: Head side and kept		-RL: Rod side and kept		-HL: Head side and kept		-RL: Rod side and kept	
	X	Y	X	Y	X	Y	X	Y
18	25.5	25.5	45.5	5.5	13.5	25.5	33.5	5.5
20	29.5	26.5	49.5	6.5	17.5	26.5	37.5	6.5
25	34.5	25.5	54.5	5.5	22.5	25.5	42.5	5.5

● Sensor switch mounting surfaces

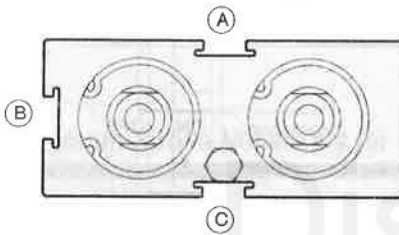

Rod side and head side stroke end can be detected when mounting sensor switches on one or two of the (A), (B), or (C) sides. Drawing is shown from end plate.

Dimensions of Sensor Switch

● $\phi 10 \sim \phi 25$

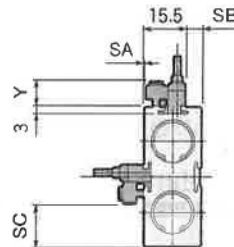
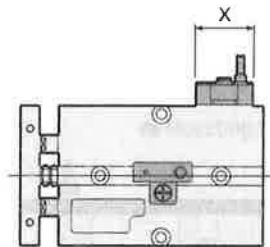

● $\phi 32$

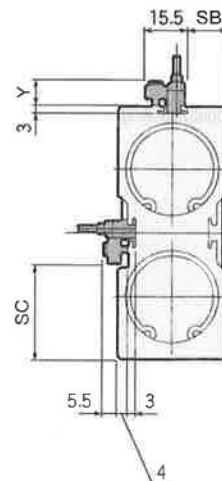
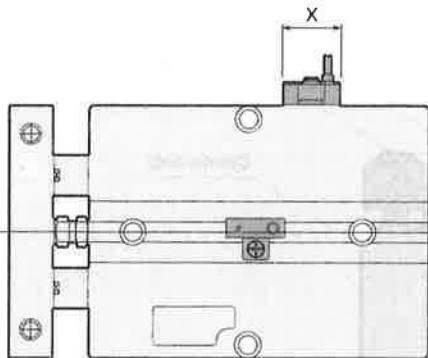

Cylinder bore size	Symbol	CS□H□		ZB□□		SA	SB	SC
		X	Y	X	Y			
10						3	4.5	10
18						0.5	6	16
20		22	9.5	34	14	—	8	20
25						—	10.5	25.5
32						—	15.5	37

Short Stroke Sensor Switch

Extra Short Type • Short Type

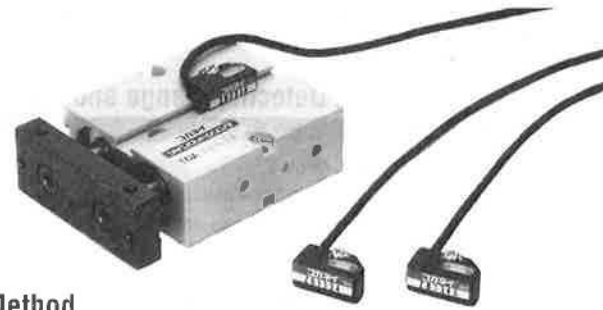

Characteristics of Short Stroke Sensor Switches

In the past, two sensor switches were installed for detection at both ends of the cylinder, but now we can detect at both ends with one "short stroke sensor switch". In that way the number of cable wires decreases by half, wiring space and manhours are reduced, and wiring and manhours can be conserved. Furthermore, by mounting the "extra short type (ZB333)" designed for relatively short stroke cylinders, it is possible to detect at both ends of an approximately 3 mm short stroke without an overlap signal, a task which used to be difficult.

Operation Summary of Short Stroke Sensor Switches

Short stroke sensor switch has two built-in LEDs and output for two channels to detect both rod-side and head-side stroke ends.

The relationship between LED and OUT (output) is shown below. When OUT 1 is turned ON, LED 1 is turned ON, and when the OUT 2 is turned ON, the LED 2 is turned ON. The direction of the stroke corresponds to the LED indicator. Under the example of mounting method shown below, when LED 1 is ON, it will detect rod-side stroke end of the cylinder; and when LED 2 is ON, it will detect head-side stroke end of the cylinder.

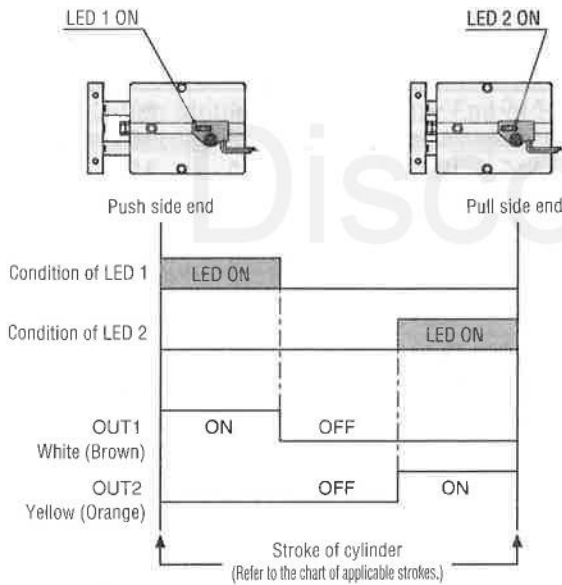

Note: The color of lead wire will be changed to colors in the parentheses in 1993.

Order Example (for sensor switch only)

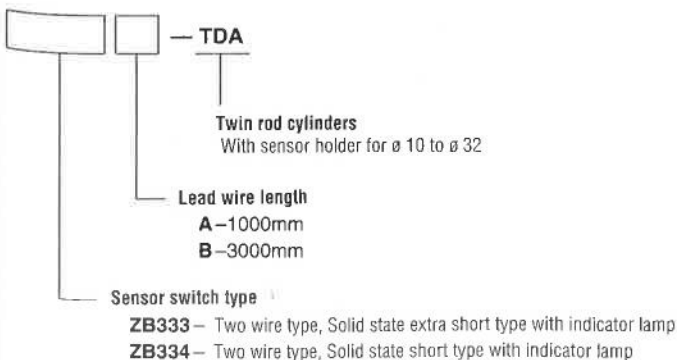

Selection Method

There are two types of short stroke sensor switches depending on the OFF range difference: super-short type, and short type. You can detect most accurately by choosing a sensor switch following these selection steps:

Step 1: Short stroke sensor switches can be used when the stroke (actual stroke used) is 20mm or less. Measure cylinder bore size and actual stroke size.
Example: Cylinder bore size: $\phi 16$ twin rod cylinder
Actual stroke: 8mm

Step 2: Decide on the cylinder type using step 1.
Example: If actual stroke is 8mm, use a 10mm standard stroke and adjust its size to 8mm with a stopper bolt.
Thus, cylinder model will be **TDA16 \times 10**.

Step 3: Select either the super-short type or short type after checking the "Detectable actual stroke list." Note that super-short type (ZB334) and short type (ZB333) have different OFF ranges. (Refer to the chapters on sensor switch detection range and operating range.)

Example: For a $\phi 16$ cylinder bore and actual stroke of 8mm, select a short type (ZB334) using the "Detectable actual stroke list."
The model to order is **TDA16 \times 10-ZB334** 1.

Detectable Actual Stroke List

Cylinder	Cylinder bore size	Actual stroke mm																	
		3	4	5	6	7	8	9	10	11	12	13	14	15	16	17	18	19	20
Twin rod cylinder	10																		
Double acting: TDA	16																		
Double acting, long bushing type: TDAM	20																		
Single acting push type: TSA	25																		
End-keep type: TDAM	32																		

ZB333 (super-short type); ZB334 (short type)

Note 1: The above chart shows detectable actual cylinder strokes measured within the OFF ranges of each ZB333 and ZB334 short stroke sensor switch.

2: As shown in the chart, super-short type (ZB333) can be used for strokes of 5mm or more (6 to 11 mm parts). However the OFF range will become shorter and the ON range will lengthen.

3: Please adjust the stopper bolt on the cylinder body for intermediate strokes other than standard strokes of 10mm or 20mm. See p.341 for adjustment method.

4: 32mm cylinder bore size not available for single acting push type and end-keep type.

Sensor Switch Detecting Range and Operating Range

● Maximum detecting range: ℓ

This refers to the range from the position where the sensor switch OUT 1 is turned on to where OUT 1 is turned off; plus where OUT 2 is turned on by the piston movement in the same direction up to the point where OUT 2 is turned off.

● Operation range 1 and operation range 2

Operation range 1 refers to the range from the position where the sensor switch OUT 1 is turned on by the piston movement to the point where the switch OUT 1 is turned off. Operation range 2 refers to the range from the position where the switch OUT 2 is turned on to the point where it is turned off.

● OFF range

This refers to the range where both OUT 1 and OUT 2 are off (from the point where the switch OUT 1 is turned off to the point where the switch OUT 2 is turned on; and in the opposite direction, from the point where the switch OUT 2 is turned off to the point where the switch OUT 1 is turned on.)

● Central detection point

This refers to the center point of the above mentioned OFF range.

● Response differential

This refers to the distance between the point where the piston (magnet) turns the switch ON, and the point where the switch turns OFF as the piston (magnet) travels in the opposite direction (see drawing). Response differential in the short stroke sensor switch indicates the values adjacent to the OFF range among the two response differentials of operation ranges 1 and 2.

Operation indicator lamp

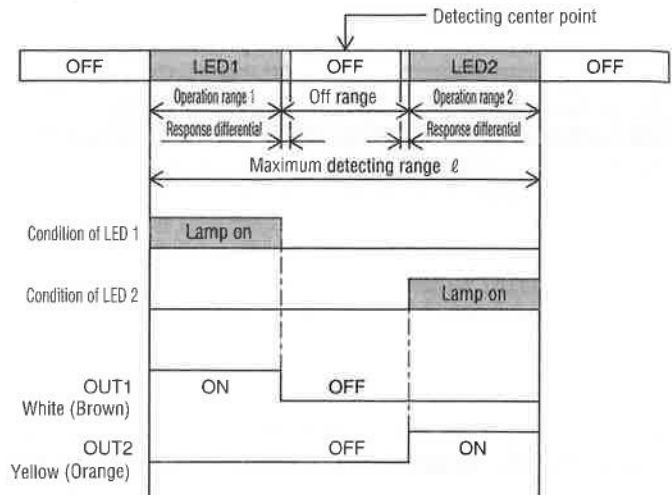

Note: The color of lead wire will be changed to colors in the parentheses in 1993.

■ Extra short type (ZB333)

Bore size	Mounting surface	Maximum detecting range	Operating range 1, 2	Off range	Response differential
10	A · C	15.0~15.5	6.0~7.5	0.6	0.5 or less
	B	16.5~17.0	7.0~8.5	0.5	0.6 or less
16	A · C	15.5~16.5	6.5~7.5	0.7	0.4 or less
	B	16.0~18.5	5.5~9.0	0.6	0.4 or less
20	A · C	18.0~18.5	7.0~8.5	0.7	0.6 or less
	B	17.0~19.0	6.0~9.5	0.6	0.6 or less
25	A · C	20.5~23.0	6.5~10.0	0.7	0.4 or less
	B	18.0~20.0	6.5~10.0	0.8	0.4 or less
32	A · C	23.0~24.0	6.5~9.5	1.0	0.6 or less
	B	21.5~25.0	5.0~12.0	1.2	0.6 or less

Note: The chart indicates reference values.

■ Short type (ZB334)

Bore size	Mounting surface	Maximum detecting range	Operating range 1, 2	Off range	Response differential
10	A · C	15.0~15.5	5.0~6.5	4.0	0.8 or less
	B	16.5~17.0	6.0~7.5	3.5	0.9 or less
16	A · C	15.5~16.5	5.5~6.5	4.5	1.0 or less
	B	16.0~18.5	4.5~8.0	3.5	1.1 or less
20	A · C	18.0~18.5	6.0~7.5	5.0	1.1 or less
	B	17.0~19.0	5.0~8.5	4.0	1.1 or less
25	A · C	20.5~23.0	5.5~9.0	6.5	1.1 or less
	B	18.0~20.0	5.5~9.0	4.5	0.9 or less
32	A · C	23.0~24.0	6.5~8.5	8.0	1.2 or less
	B	21.5~25.0	4.0~11.0	7.0	1.2 or less

Note: The chart indicates reference values.

● Sensor switch mounting side

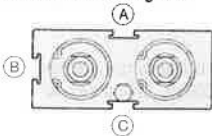

The fully extended or fully retracted position of the piston rod at rod-side or head-side can be detected when mounting sensor switch on one of (A), (B), or (C) sides. Drawing is shown from end plate.

Maximum Sensing Determination Procedure

Set the proper position of the sensor switch by the following two procedures:

● Using dimension chart

Set mounting location according to the "stroke end detection mounting location" chart. After mounting, move the piston to make sure that it correctly operates.

● Adjusting mounting location while operating

■ If you desire correct positioning from the push side end then:

1. Pull the piston up to the rod side stroke end.
2. Move the temporarily installed sensor switch from the head side to the rod side until the LED indicator lamp (LED 1) is turned on in the direction of the rod side. Next, tighten the set screws at the point where the sensor switch returns 1-2mm toward the head side and turned the indicator lamp off. At this point LED1 is turned on again. (Refer to figure 1).
3. Push in the piston up to the head side stroke end. At this point reconfirm the head side LED indicator (LED 2) is turned on (with 1mm or more operating range.) (Refer to figure 2).

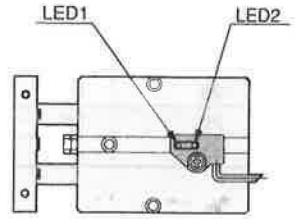

(Figure 1)

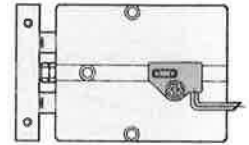

(Figure 2)

■ If you desire correct positioning from the pull side end then:

1. Pull the piston up to the head side stroke end.
2. Move the temporarily installed sensor switch from the rod side to the head side until the LED indicator lamp is turned on in the direction of the head side. Next, tighten the set screws at the point where the sensor switch returns 1-2mm toward the rod side and turned the indicator lamp off. At this point LED2 is turned on again. (Refer to figure 2).
3. Push in the piston up to the rod side stroke end. At this point reconfirm the rod side LED indicator (LED 1) is turned on (with 1mm or more operating range.) (Refer to figure 1).

Sensor Switch Mounting Location for End of Stroke Positioning

1. When the sensor switch is mounted in the position shown in the chart below (X or Y value), cylinder stroke end can be detected.
2. X and Y values (reference values) in the chart indicate the distance from the cylinder end (rod end or head end) to the sensor end when matching the detected center point of the sensor switch with the actual stroke center point.
3. The sensor switch might be longer than the cylinder body depending on mounting condition.

■ Double acting type

Symbol	Cylinder bore size	10	16	20	25	32
X		22.5	28.5	32.5	37.5	47
Y		1.5	2.5	3.5	2.5	9

mm

■ Double acting long bushing type

Symbol	Cylinder bore size	10	16	20	25	32
X		32.5	38.5	42.5	47.5	57
Y		1.5	2.5	3.5	2.5	9

mm

■ Single acting push type

Symbol	Cylinder bore size	10	16	20	25	32
X		22.5	28.5	32.5	37.5	—
Y		1.5	2.5	3.5	2.5	—

mm

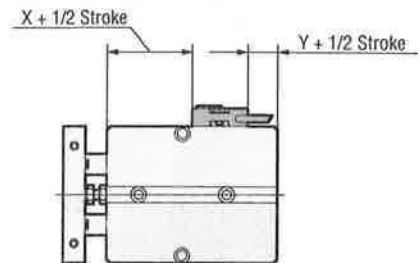

■ Head side end kept (-HL)

Symbol	Cylinder bore size	10	16	20	25	32
X		—	28.5	32.5	37.5	—
Y		—	22.5	23.5	22.5	—

mm

■ Rod-side end kept (-RL)

Symbol	Cylinder bore size	10	16	20	25	32
X		—	48.5	52.5	57.5	—
Y		—	2.5	3.5	2.5	—

mm

Note: The chart is for standard stroke cylinders.

Dimensions

(Unit mm)

Cylinder bore size	Symbol	A	SA	SB
10		17	-2.5	4
18		21	-0.5	6
20		25	1.5	8
25		30	4	10.5
32		40	9	15.5

● $\phi 10 \sim \phi 25$

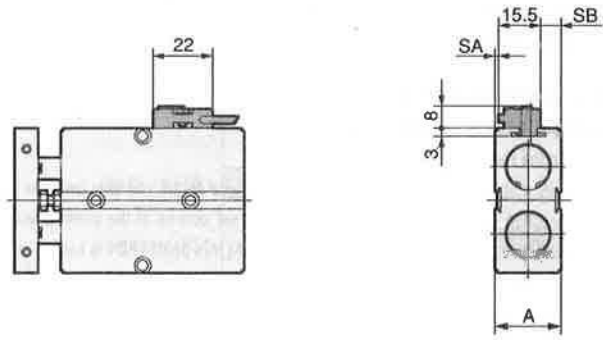

● $\phi 32$

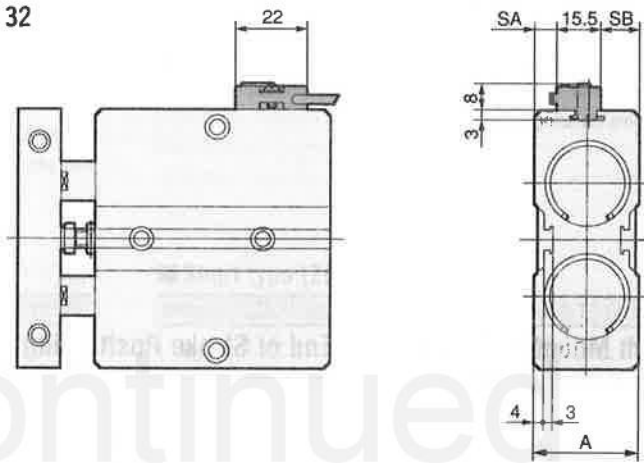

Discontinued

Handling Instruction and Points to be Considered



Mounting and stroke adjustment

Allowable Lateral Load

Lateral load on the rod bearing should be less than that indicated in the accompanying chart.

$\phi 10$

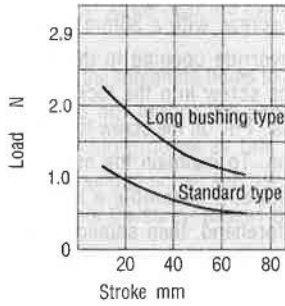

$\phi 18$

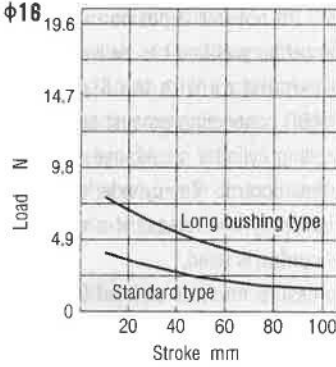

$\phi 20$

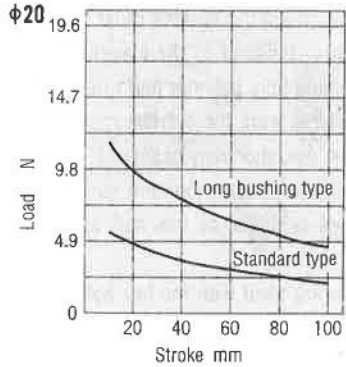

$\phi 25$

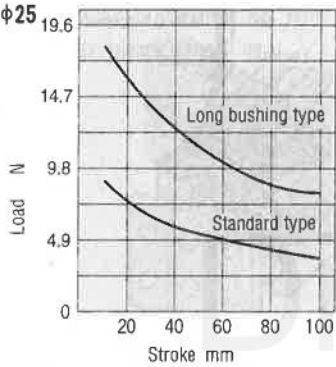

$\phi 32$

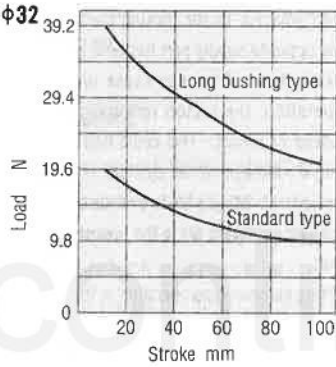

Remark: Includes end keep cylinders for 10 to 25 bore size standard cylinders

Allowable eccentricity

Eccentricity of the front plate, without load, is allowable within the following range.

— Standard type - - - - - Long bushing type.

$\phi 10$

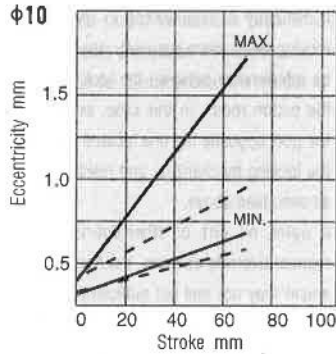

$\phi 18$

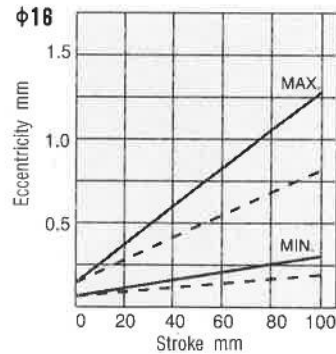

$\phi 20$

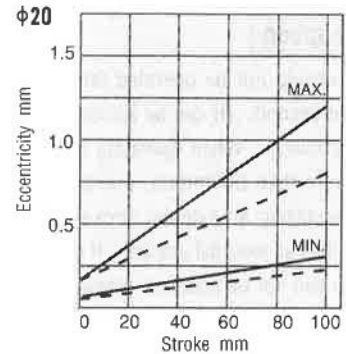

$\phi 25$

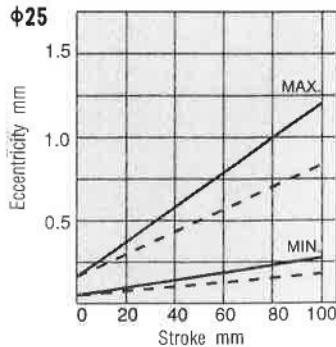

$\phi 32$

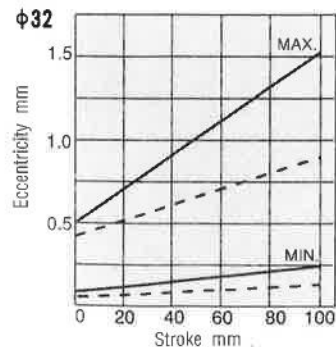

Remark: Includes end keep cylinders for 10 to 25 bore size standard cylinders



Mounting and Stroke Adjustment

Mounting

1. Cylinders can be mounted in any direction; however, mounting surface must be flat. If bending or twisting of the cylinder occurs during mounting, cylinder performance may be interfered with, the cylinder may leak, or improper operation may occur.
2. Do not damage the mounting surface with scratches or dents, as this may affect surface flatness.
3. Washers are used with the hex bolts on the cylinder rod front plate. Make sure bolts are tight before using the cylinder.

Stroke adjustment

The stroke of the twin rod cylinders can be easily adjusted within a range of -5 to 0mm (excluding -HL: Head-side end kept cylinders). To adjust stroke, turn stopper bolt counter-clockwise to obtain shorter stroke length. After adjustments have been made, re-tighten the lock nut. Do not over tighten past the standard location. The stroke at the time of shipment is in the standard location. It is impossible to adjust stroke past the standard location. Do not adjust stroke of end keep cylinders by such means as an external stopper on the side with an end keep mechanism, as this may prevent the lock mechanism from working properly.

Cylinder speed

Cylinders should not be operated faster than 500mm per second. (It can be adjusted using speed controller.) When operating cylinders rapidly (more than 500mm/s), prevent direct shock by installing an external stroke limiting device such as an external stopper. If an external stopper can not be installed, please consult us.



Control circuit of end keep cylinders

1. Use of a 2-position, 4- or 5-port valve is recommended to control twin rod end keep cylinders. Do not use 3-position valves in which the center position has delivery ports open to exhaust as with the 3-position valves of ABR connecting exhaust center.
2. For controlling cylinder speed, use a meter-out type flow control. The cylinder's locking mechanism may not release if a meter-in type flow control is used.
3. Supply pressure must be at least 0.15MPa (1.5kgf/cm²).

Cautions 1. Do not allow compressed air into the supply port adjacent to the locking mechanism if the opposite supply port has been previously exhausted. This may cause unintended operation; the piston rod may suddenly extend or retract. This could lead to injury, and/or damage to the cylinder or adjacent equipment. Make sure to provide back pressure by supplying air to the opposite side of port.

2. Before commencing operation of the cylinder after it has been completely exhausted such as prior to start up, or after an emergency stop, first pressurize the supply port opposite the one nearest the locking mechanism.
3. Connect A-port (N/C) of the valve to the port nearest the locking mechanism.



Manual Operation of Locking Mechanism

The locking mechanism can be automatically released during normal cylinder operation, but it can also be done manually. For manual operation, insert a M3x0.5 (M2.5x0.45 for $\phi 16$) threaded screw, with a 30mm neck, into the manual override opening in the mechanism. Thread the screw into the lock piston, about three turns. Pull on the screw to disengage the lock piston. To maintain the manual override for adjustment, assemble a locknut to the screw beforehand, then shoulder the locknut against the cylinder after the lock has been released.

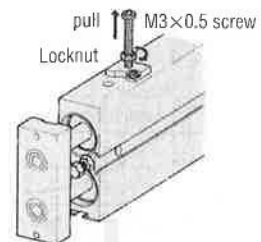

- Cautions** 1. Do not release locking mechanism when a load is present on the piston rods. This may cause unintended operation which could result in injury or damage to equipment. When releasing the locking mechanism, be sure that air is supplied to the port opposite the port adjacent to the locking mechanism, then release mechanism.
2. If difficulty is experienced in releasing the locking mechanism manually, the cause may be interference between the lock piston and the piston rods. In this case, supply air to the port opposite the one located adjacent to the locking mechanism, and release the lock as described above.
 3. If water, oil, dirt, or other debris enter the manual override opening, the locking mechanism may not pull out sufficiently to disengage the piston rod. Provide adequate protection such as a cover to avoid this condition if used in adverse environments.



Sensor Switches

1. Standard cylinders have built-in magnets for the operation of sensor switches. When sensor switches are mounted on cylinders, they become sensor cylinders.
2. Mount the sensor switch in the mounting grooves on the cylinder body by locating the sensor switch screw near the cylinder piping port.
3. When using the mounting holes to mount the cylinder, do not mount the sensor in the same mounting grooves as this will cause the body mounting screw and sensor switch to meet where the screw passes through the cylinder body.
4. Sensor switches cannot be mounted as shown below as this will result in the sporadic action of the switches. When mounting this way, please consult us.

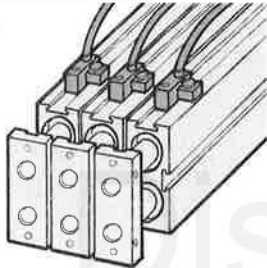

5. When planning to use two sensor switches on a cylinder with only 10mm stroke, please consult us.

- Note: 1. Refer to pages 332, 333, and 336 for mounting locations and moving sensor switches.
2. When connecting inductive load to reed-switch type sensor switches or capacitive surges occur, circuit protection will be needed. Refer to page 680 for circuit protection measures.



General Cautions

Fluid

1. Use compressed air as fluid. Consult us if using any other fluid.
2. Air should be clean, dry, uncontaminated and contain no oil particles. An air filter (filtration ratio of less than 40 μ m) should be installed near the cylinder and valves. Periodically remove, drain, clean or replace filter element.
If dust is present in the cylinder, it may result in malfunction.

Lubrication

No lubrication is required. However, if lubrication is used, apply Class 1 turbine oil (ISO VG32) or equivalent. Do not use spindle oil or machine oil.

Atmosphere

1. When operating in ambient conditions such as excessive dust or exposure to water or oil particles, install appropriate protective devices such as a cover.
2. When media or the atmosphere contains the following substances, it should not be used: organic solvents, phosphoric acid ester-type machine oil, sulfuric acid gas, chlorine gas, or acids.

Information of high position control and high rigidity type twin rod cylinders

Koganei twin rod cylinders have high position control and high rigidity type series. Refer to the separate catalog for more details.

Alpha series twin rod cylinders

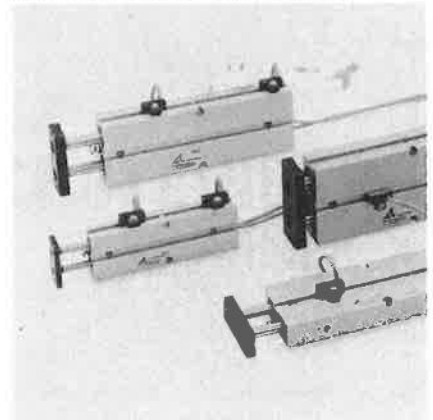

● Catalog No.: C2039