

Low Speed Cylinders

Slow, smooth, and stable operation!

- Enable stable operation from 1mm/s [0.04in./sec.].^{Note}
- Smooth operation without stick-slips.
- Suitable for low speed transfer of fragile workpieces.
- Cylinder's outer dimensions are the same as the standard product.
- Wide range of cylinders are available: 6 types and 10 bore sizes.
- Speed controllers for low speed cylinders are also available.

Note : Excluding Jig cylinders with guides.



Slow and smooth



CAUTION

Always wash your hands thoroughly whenever you happen to touch the grease used in the Low Speed Cylinders. If you light a cigarette with greasy hands, the grease adhered to the cigarette could release toxic gases as it burns. (While the grease used in the Low Speed Cylinder is very stable in chemical terms at room temperature, it would release toxic gases if heated to 250°C [482°F] or higher.)

Waveform of Speed and Displacement

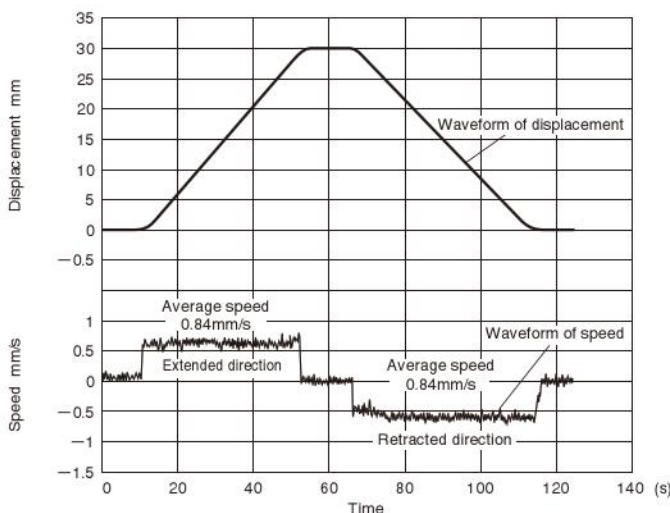

Remarks 1 : The average speed is obtained by dividing the stroke by the time required to travel the stroke. The above average speed values were obtained by tests undertaken at Koganei. They do not imply guaranteed values of the product.

2 : The speed value reads positive when the cylinder is extended.

1mm/s = 0.03944in./sec. 1mm = 0.0394in.

Measurement method

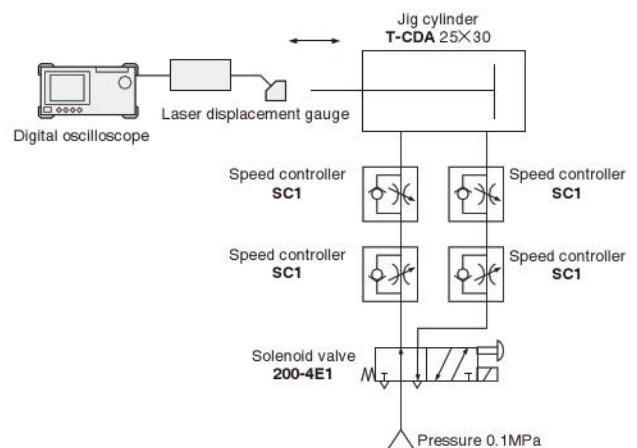

Low Speed Cylinder Variations

Twin Rod Cylinders —1538

Jig Cylinders with Guides —1539

Jig Cylinders C Series—1535

Both

Speed controller
Improved characteristics
In low-flow area.
 You can make full use of the capabilities of the Low Speed Cylinders by using the speed controllers.

Slim Cylinders —1537

Multi Mount Cylinders —1536

Pen Cylinders —1534

Low speed Control Type Speed Controllers with Quick Fittings —1540

Handling Instructions and Precautions —1533

Application Examples

● Positioning a wafer stacker

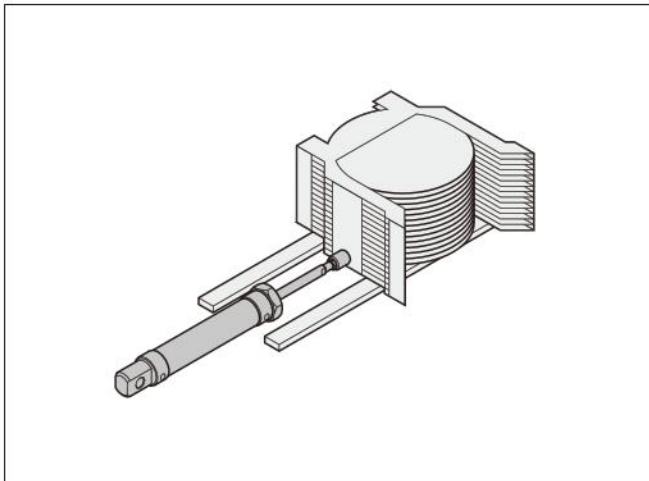

● Transfer of a liquid crystal display panel

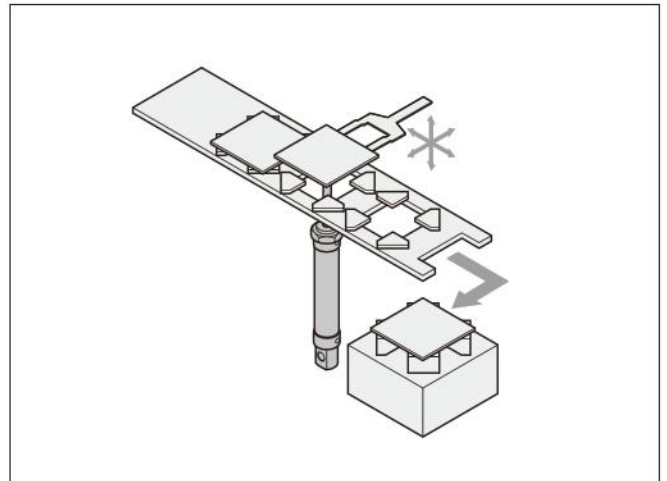

LOW SPEED CYLINDERS

Handling Instructions and Precautions



General precautions

1. Always thoroughly blow off (use compressed air) the tubing before piping. Entering metal chips, sealing tape, rust, etc., generated during piping work could result in air leaks or other defective operation.
2. Use air for the media. For the use of any other media, consult us.
3. Air used for the cylinder should be clean air that contains no deteriorated compressor oil, etc. Install an air filter (filtration of a minimum 40 µm) near the cylinder or valve to remove collected liquid or dust. In addition, drain the air filter periodically. Collected liquid or dust entering the cylinder may cause improper operation.



Piping

See the diagrams below for piping with the Low Speed Cylinder.

Recommended circuit

① Basic circuit

Use meter-out speed controllers.

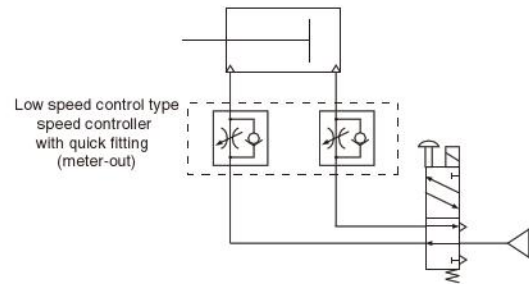

② Jump start prevention circuit

Use in combination with speed controllers, as shown in the diagram below, is effective for low speed control as well as jump start prevention.

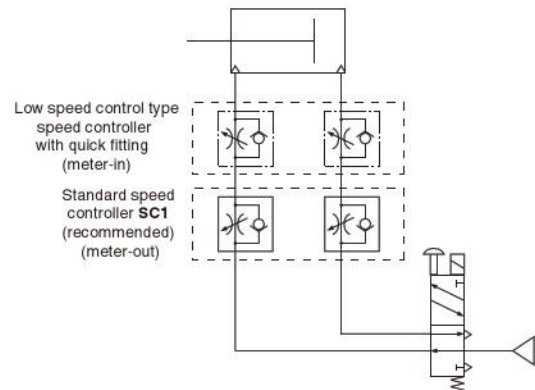

Note: Locate the cylinder and speed controller as close to each other as possible.

