

High-quality stainless steel cylinders ahead of all others

# SLIM CYLINDERS

## Use durable piston seals.

The two piston seals are the durable PPY type. This prevents inner air leakage, and achieves smooth operation from low-speed to high-speed ranges.

## Sensor switches can be installed anytime after cylinder installation.

Magnets as standard equipment across the entire series allow sensor switches to be installed anytime after the cylinder has been installed.

## High installation accuracy and simple mounting operations.

A centering location on the rod cover improves mounting precision. Moreover, the mounting nut's improved thread precision means that holding the cylinder body in place by hand is sufficient for mounting nut tightening operations. Mounting in hard-to-reach places is easy.

## Criteria for Selection: Slim Cylinder Allowable Kinetic Energy

Slim cylinders (with the exception of heat resistant specifications) include a cushioning mechanism.

This mechanism is intended to reduce as much as possible the impact of pistons with high kinetic energy when they stop at the end of the stroke. There are two types of cushions, as shown below.

### ● Rubber bumpers (Standard equipment)

Rubber bumpers installed on both sides of the piston soften the impact at the end of the stroke, and absorb the impact noise during stopping, in response to high-frequency and high-speed operations. They are standard equipment across the whole series, with the exception of heat resistant specifications.

Note that a certain amount of rebound will occur at the end of the stroke on the cylinder with the rubber bumpers.

### ● Variable cushions

Use variable cushions for large load or high-speed operations that rubber bumpers cannot adequately absorb. The impact is absorbed by compressing air, when the piston stops at the end of the stroke.

Since the cushioning stroke is included within the cylinder stroke, be careful to ensure that the cushion is not excessively performed during cylinder applications of 25mm strokes or less. An excessively performed cushion can result in too much time for each stroke, reducing efficiency. When operated at or below the absorbable kinetic energy shown in the table below, the cushion seal life is 1 million operations or more.

The load kinetic energy can be obtained through the formulas shown below.

$$E_x = \frac{m}{2} v^2$$

Ex: Kinetic energy (J)  
m: Load mass (kg)  
v: Piston speed (m/s)

$$E'_x = \frac{W}{2g} v'^2$$

E'x: Kinetic energy [ft·lbf]  
W: Load [lbf.]  
v': Piston speed [ft./sec.]  
g: Acceleration of gravity 32.2 [ft./sec.<sup>2</sup>]

### Operating speed range

- Rubber bumper ..... 30~800mm/s [1.2~31.5in./sec.]
- Variable cushion ..... 30~1000mm/s [1.2~39.4in./sec.]

Bore size mm [in.]	Allowable kinetic energy J [ft·lbf]	
	With rubber bumpers	With variable cushion
16 [0.630]	0.07 [0.052]	0.18 [0.13]
20 [0.787]	0.27 [0.20]	0.7 [0.52]
25 [0.984]	0.40 [0.30]	1.05 [0.77]
32 [1.260]	0.65 [0.48]	1.8 [1.33]
40 [1.575]	1.2 [0.89]	2.8 [2.07]
50 [1.969]	—	3.5 [2.58]
63 [2.480]	—	4.5 [3.32]

Rubber bumper (Graph 1)



Variable cushion (Graph 2)

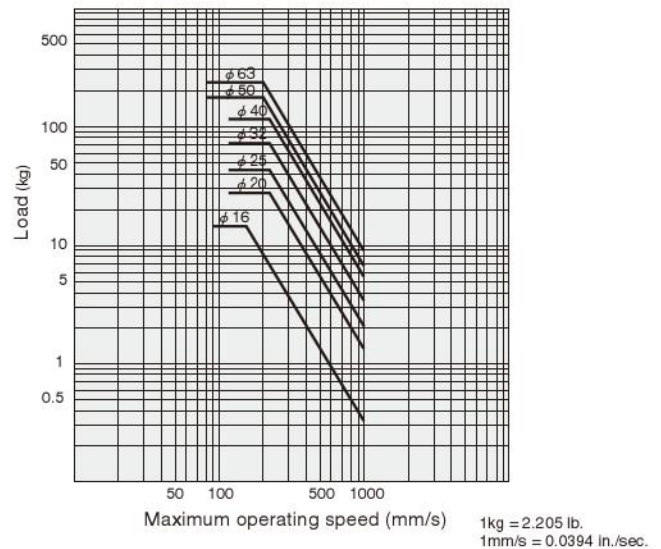

### How to read the graphs

From Graph 1, the capacity of the rubber bumpers limits the maximum speed to 500mm/s [19.7in./sec.] or less when a φ32 Slim Cylinder is used to carry a load of 5kg [11.0lb.].

From Graph 2, a φ32 cylinder with variable cushion can be selected to carry a load of 8kg [17.6lb.] at a maximum speed of 600mm/s [23.6in./sec.].

# MADE TO ORDER PRODUCT

## All SUS Type Cylinders

● For delivery, consult us.



SLIM CYLINDERS

### Symbol

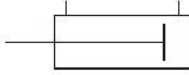

### Specifications

Item	Bore size mm [in.]	20, 25, 32, 40 [0.787, 0.984, 1.260, 1.575]
Operation type		Double acting type
Media		Air
Mounting type		Basic type
Operating pressure range	MPa [psi.]	0.04~0.9 [6~131]
Proof pressure	MPa [psi.]	1.32 [191]
Operating temperature range	°C [°F]	0~70 [32~158]
Operating speed range	mm/s [in./sec.]	30~700 [1.2~27.6]
Cushion		Fixed type (Rubber bumper)
Lubrication		Not required
Port size	Rc	1/8

### Bore Size and Stroke

Bore size	Standard strokes								Maximum stroke	Maximum available stroke
	25	50	75	100	125	150	200	250		
20									200	1050
25	25	50	75	100	125	150	200		250	
32	25	50	75	100	125	150	200		300	
40	25	50	75	100	125	150	200	250	300	

Remarks: 1. Stroke tolerance  ${}^+1_0 \left[ \begin{smallmatrix} +0.039in. \\ 0 \end{smallmatrix} \right]$

2. For non-standard strokes, consult us.

3. The minimum operating pressure when the stroke is over the maximum stroke at bore size of  $\phi 20 \sim \phi 40$  is 0.2MPa [29psi.].

### Order Codes

**SUS** — **DA** **20×50** — [ ] — [ ] [ ] [ ]

**Slim double acting cylinder**

**SUS specification**

**Bore size × Stroke**

**Head cover specification**  
**Blank** — Standard head  
**A** — Short head

**Number of sensor switches**  
**1** — With 1 sensor switch  
**2** — With 2 sensor switches  
**3** — With 3 sensor switches  
 ⋮

**Lead wire length** (Applies to all except **CS□F**)  
**A** — 1000mm [39in.]  
**B** — 3000mm [118in.]

**Sensor switch** (for cylinders with sensor switches)  
**Blank** — No sensor switch  
**ZG530** — 2-lead wire Solid state type with indicator lamp DC10~28V  
**ZG553** — 3-lead wire Solid state type with indicator lamp DC4.5~28V  
**CS3M** — Reed switch type with indicator lamp DC10~30V  
**CS4M** — Reed switch type with indicator lamp AC85~230V  
**CS5M** — Reed switch type without indicator lamp DC10~30V  
**CS2F** — Reed switch type with indicator lamp AC85~115V  
**CS3F** — Reed switch type with indicator lamp AC85~115V  
**CS4F** — Reed switch type with indicator lamp DC3~30V  
**CS5F** — Reed switch type without indicator lamp DC10~30V  
 DC10~30V

● For details of sensor switches, see p.1544.  
 ● **CS□F** comes with DIN connector. All others are grommet type.

# Inner Construction and Major Parts

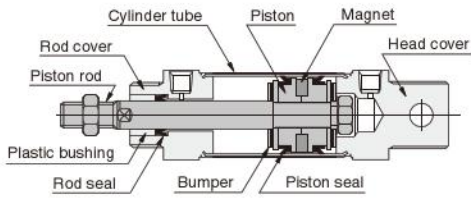

## Major Parts and Materials

Parts	Bore size	20~40
Cylinder tube		Stainless steel
Piston		Plastic
Piston rod		Stainless steel (hard chrome plated)
Rod cover		Stainless steel
Head cover		
Seal		Synthetic rubber (NBR)
Bumper		Synthetic rubber (NBR)
Magnet		Plastic magnet

## Dimensions of All SUS Type Cylinder Basic Type (mm)

● Basic type SUS-DA  ×

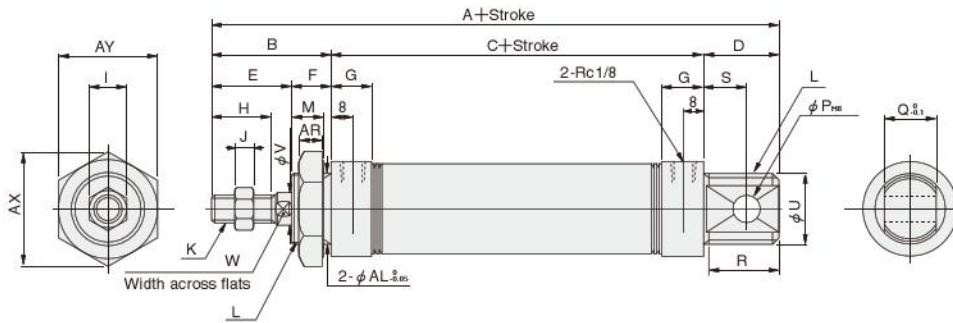

● Short head

SUS-DA  ×  -A

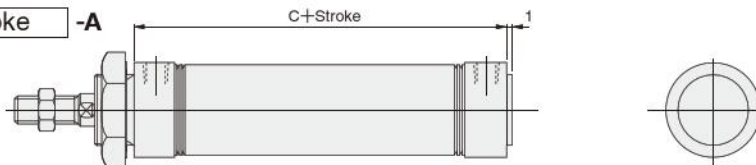

Code	A	B	C	D	E	F	G	H	I	J	K	L	M	P	Q	R	S	U	V	W
20 [0.787]	132	35	76	21	23	12	16	15	12	5	M8×1	M20×1.5	10	8	12	19	12	27	8	6
25 [0.984]	137	40	76	21	26	14	16	18	14	6	M10×1.25	M22×1.5	12	8	12	19	12	29	10	8
32 [1.260]	148	45	76	27	31	14	16	23	14	6	M10×1.25	M27×2	12	10	20	25	15	35	12	10
40 [1.575]	148	45	76	27	31	14	(14.5)	23	19	8	M14×1.5	M33×2	12	10	20	25	15	41.6	16	14

Code	AR	AX	AY	AL
20 [0.787]	7.5	31.2	27	20
25 [0.984]	9.5	34.6	30	22
32 [1.260]	9.5	41.6	36	27
40 [1.575]	9.5	47.3	41	33

# OPTIONAL ROD END SHAPE PATTERNS

Use an order form of rod end pattern and fill the items on the selected one from among 28 types of optional patterned shapes to obtain made-to-order cylinders of non-standard rod end shapes.

The shapes can be applied to the entire Slim cylinders series with the exception of square rod cylinders and cylinders with bellows. For the order form containing the optional patterned shapes, consult us.

## Order Codes

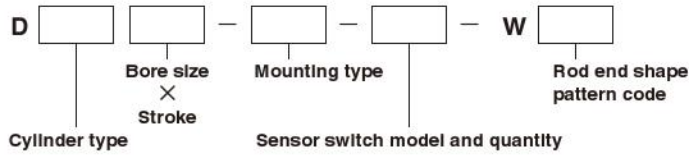

## Piston Rod End Shape Pattern Diagram (28 Types)

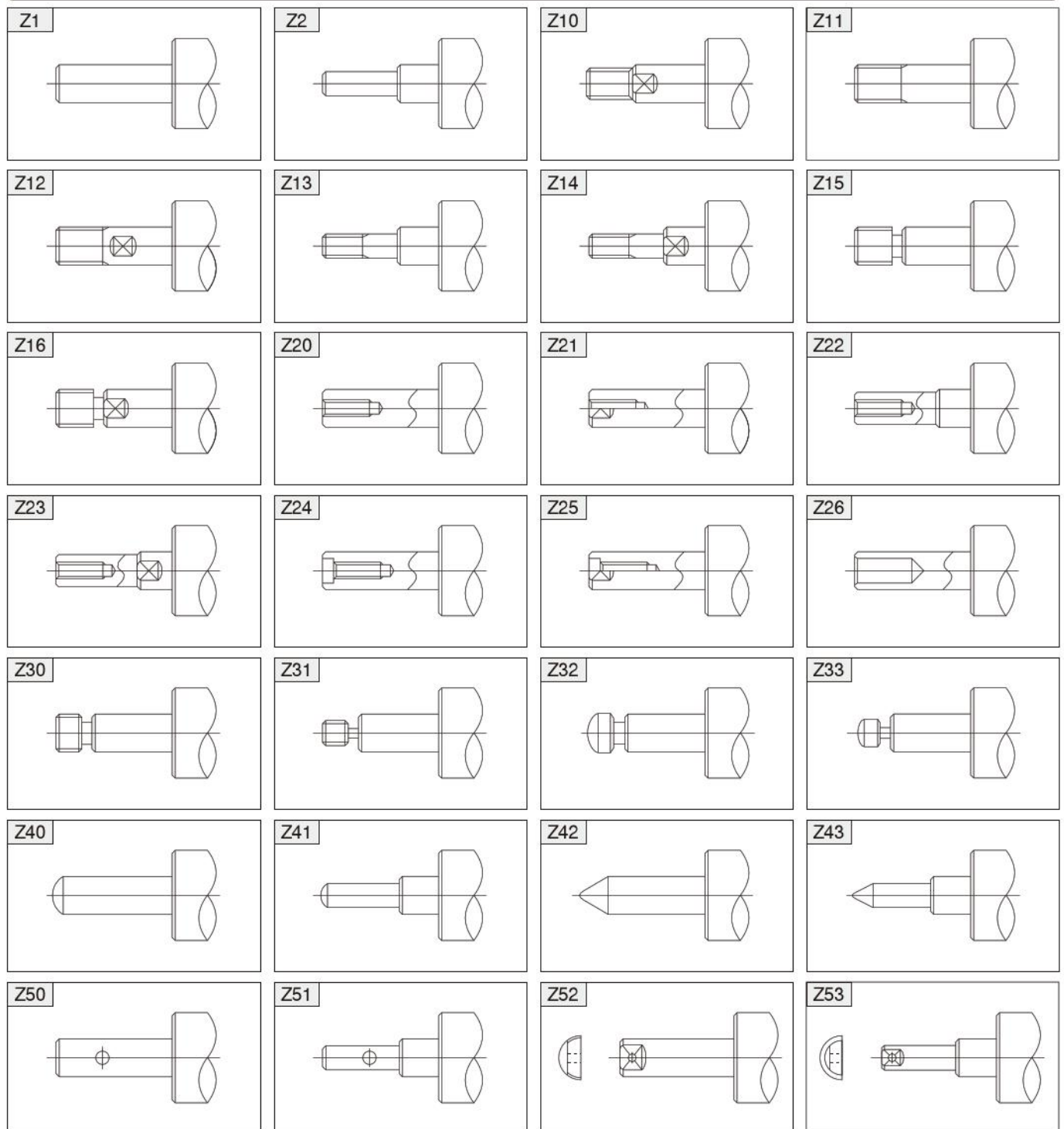

# SENSOR SWITCHES

## Solid State Type, Reed Switch Type

- Since a magnet is already standard on the Slim cylinders series<sup>Note</sup>, mounting a sensor switch will enable use in sensor switch applications.

Note: Except the heat resistant specification cylinder.

### Symbol

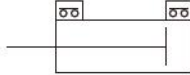

### Order Codes

- Order codes for sensor switches mounted on the Slim cylinders

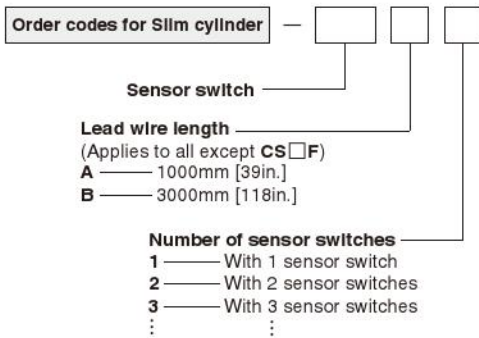

Sensor switch			
<b>ZG530</b>	Solid state type	For $\phi 16 \sim \phi 63$ with indicator lamp	DC10~30V
<b>ZG553</b>	Solid state type	For $\phi 16 \sim \phi 63$ with indicator lamp	DC4.5~28V
<b>CS3M</b>	Reed switch type	For $\phi 16 \sim \phi 63$ with indicator lamp	DC10~30V
<b>CS4M</b>	Reed switch type	For $\phi 16 \sim \phi 63$ with indicator lamp	AC85~230V
<b>CS5M</b>	Reed switch type	For $\phi 16 \sim \phi 63$ without indicator lamp	DC10~30V
<b>CS2F</b>	Reed switch type	For $\phi 20 \sim \phi 63$ with indicator lamp	AC85~115V
<b>CS3F</b>	Reed switch type	For $\phi 20 \sim \phi 63$ with indicator lamp	DC3~30V
<b>CS4F</b>	Reed switch type	For $\phi 20 \sim \phi 63$ with indicator lamp	AC85~115V
<b>CS5F</b>	Reed switch type	For $\phi 20 \sim \phi 63$ without indicator lamp	AC85~230V
			DC10~30V
			DC3~30V

- Order codes for sensor switch only

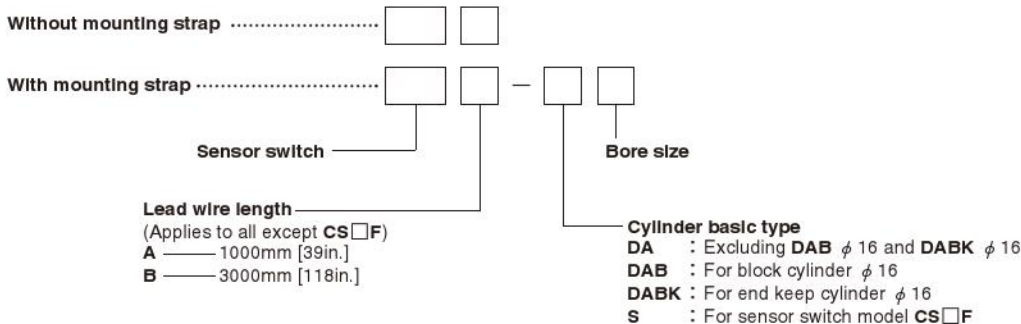

- Order codes for mounting strap only

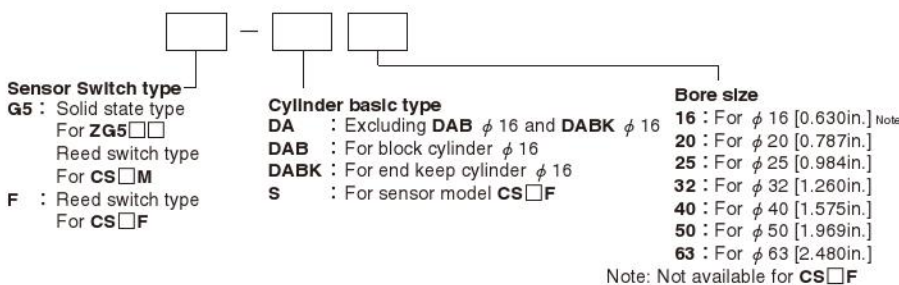

Note: Not available for CS□F

## Minimum Cylinder Strokes When Using Sensor Switches

Sensor switch model	Bore size	2 pcs. mounting		1 pc. mounting
		Along a straight line	In staggered positions	
		mm		
ZG530	16	20	10	10
ZG553	20~63	20	10	10
CS□M	16~63	20	15	15
CS□F	20~63	40	21	15

### ● Two pieces mounting ● One piece mounting

● When mounted in-line

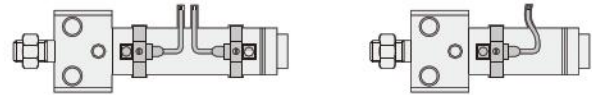

● When mounted in staggered positions

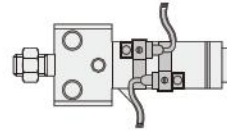

## Sensor Switch Operating Range, Response Differential, and Maximum Sensing Location

### ● Operating range : $\ell$

The distance the piston travels in one direction, while the switch is in the ON position.

### ● Response differential : C

The distance between the point where the piston turns the switch ON and the point where the switch is turned OFF as the piston travels in the opposite direction.

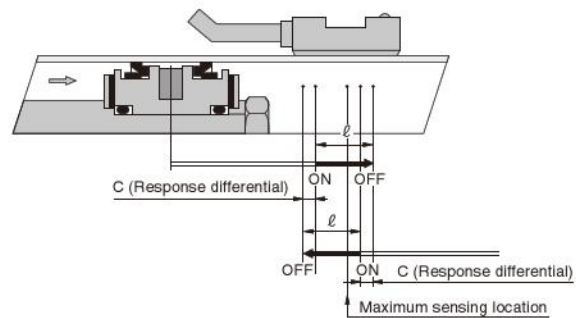

Item	Bore size	mm [in.]						
		16 [0.630]	20 [0.787]	25 [0.984]	32 [1.260]	40 [1.575]	50 [1.969]	63 [2.480]
Operating range : $\ell$	ZG530□	2.5~4.1 [0.098~0.161]	2.5~4.2 [0.098~0.165]	2.6~4.3 [0.102~0.169]	3.0~4.8 [0.118~0.189]	3.1~5.0 [0.122~0.197]	3.3~5.4 [0.130~0.213]	3.5~5.7 [0.138~0.224]
	ZG553□	—	—	—	—	—	—	—
	CS□M	6.7~7 [0.264~0.276]	7~8.5 [0.276~0.335]	7~8.5 [0.276~0.335]	8~9 [0.315~0.354]	9~10.5 [0.354~0.413]	7~8 [0.276~0.315]	8~9.5 [0.315~0.374]
	CS□F	—	7~8.5 [0.276~0.335]	8.5~10 [0.335~0.394]	9~10.5 [0.354~0.413]	10.5~12 [0.413~0.472]	9~10 [0.354~0.394]	9~10.5 [0.354~0.413]
Response differential : C	ZG530	0.7 [0.028] or less	0.7 [0.028] or less	0.8 [0.031] or less	0.7 [0.028] or less	0.8 [0.031] or less	0.8 [0.031] or less	0.8 [0.031] or less
	ZG553	0.7 [0.028] or less	0.7 [0.028] or less	0.8 [0.031] or less	0.7 [0.028] or less	0.8 [0.031] or less	0.8 [0.031] or less	0.8 [0.031] or less
	CS□M	1 [0.039] or less	1 [0.039] or less	1 [0.039] or less	1 [0.039] or less	1 [0.039] or less	1.2 [0.047] or less	1.2 [0.047] or less
	CS□F	—	1.5 [0.059] or less	1.5 [0.059] or less	1.5 [0.059] or less	1.5 [0.059] or less	2 [0.079] or less	1.5 [0.059] or less
Maximum sensing location	ZG530, ZG553 <sup>Note 1</sup>	11 [0.433]	11 [0.433]	11 [0.433]	11 [0.433]	11 [0.433]	11 [0.433]	11 [0.433]
	CS□M <sup>Note 1</sup>	11 [0.433]	11 [0.433]	11 [0.433]	11 [0.433]	11 [0.433]	11 [0.433]	11 [0.433]
	CS□F <sup>Note 2</sup>	—	16 [0.630]	16 [0.630]	16 [0.630]	16 [0.630]	16 [0.630]	16 [0.630]

Remark: Figures in the table above are reference values.

Notes: 1. Figures are lengths measured from the switch's opposite end side to the lead wire.

2. Figures are lengths measured from the connector side's end surface to the lead wire.

# Mounting Location of End of Stroke Detection Sensor Switch

When the sensor switch is mounted in the location shown in the diagram (figures in the table are reference values), the magnet comes to the sensor switch's maximum sensing location at the end of the stroke.

## ● Air cylinder, Low hydraulic cylinder, Valpack cylinder

- Air cylinder, Low hydraulic cylinder
- Valpack cylinder

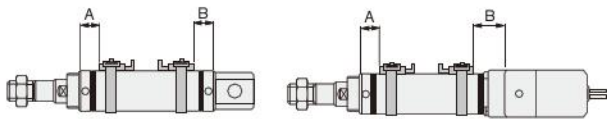

		mm [in.]									
Sensor switch model	Bore size Code	Air cylinder, Low hydraulic cylinder					Valpack cylinder				
		20	25	32	40	50	63	20	25	32	40
ZG530□ ZG553□	A	27 [1.063]	27 [1.063]	27 [1.063]	27 [1.063]	36 [1.417]	36 [1.417]	27 [1.063]	27 [1.063]	27 [1.063]	27 [1.063]
	B	27 [1.063]	27 [1.063]	27 [1.063]	27 [1.063]	36 [1.417]	36 [1.417]	39 [1.535]	39 [1.535]	39 [1.535]	44 [1.732]
CS□M	A	27 [1.063]	27 [1.063]	27 [1.063]	27 [1.063]	36 [1.417]	36 [1.417]	27 [1.063]	27 [1.063]	27 [1.063]	27 [1.063]
	B	27 [1.063]	27 [1.063]	27 [1.063]	27 [1.063]	36 [1.417]	36 [1.417]	39 [1.535]	39 [1.535]	39 [1.535]	44 [1.732]
CS□F	A	22 [0.866]	22 [0.866]	22 [0.866]	22 [0.866]	32 [1.260]	32 [1.260]	22 [0.866]	22 [0.866]	22 [0.866]	22 [0.866]
	B	22 [0.866]	22 [0.866]	22 [0.866]	22 [0.866]	32 [1.260]	32 [1.260]	34 [1.339]	34 [1.339]	34 [1.339]	39 [1.535]

## ● Single acting cylinder

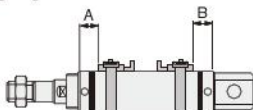

		mm [in.]				
Sensor switch model	Code	Stroke	Bore size			
			20 [0.787]	25 [0.984]	32 [1.260]	40 [1.575]
ZG530□ ZG553□ CS□M	A	0~25	35 [1.378]	36 [1.417]	35 [1.378]	37 [1.457]
		26~50	52 [2.047]	49 [1.929]	49 [1.929]	53 [2.087]
		51~75	72 [2.835]	71 [2.795]	72 [2.835]	68 [2.677]
		76~100	—	84 [3.307]	86 [3.386]	95 [3.740]
		101~125	—	—	—	110 [4.331]
		126~150	—	—	—	125 [4.921]
CS□F	A	0~25	30 [1.181]	31 [1.220]	30 [1.181]	32 [1.260]
		26~50	47 [1.850]	44 [1.732]	44 [1.732]	48 [1.890]
		51~75	67 [2.638]	66 [2.598]	67 [2.638]	63 [2.480]
		76~100	—	79 [3.110]	81 [3.189]	90 [3.543]
		101~125	—	—	—	105 [4.134]
		126~150	—	—	—	120 [4.724]
CS□F	B	—	22 [0.866]	22 [0.866]	22 [0.866]	22 [0.866]

## ● Block cylinder

- Side mount

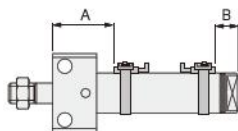

- Front mount

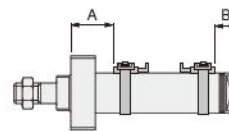

Mounting type		mm [in.]													
Bore size		Side mount					Front mount								
		16	20	25	32	40	50	63	16	20	25	32	40	50	63
ZG530□	A Rod side	32 [1.260]	39 [1.535]	41 [1.614]	47 [1.850]	57 [2.244]	67 [2.638]	67 [2.638]	23 [0.906]	27 [1.063]	27 [1.063]	27 [1.063]	29 [1.142]	37 [1.457]	37 [1.457]
ZG553□	B Rod side	16 [0.630]	20 [0.787]	20 [0.787]	21 [0.827]	25 [0.984]	45 [1.772]	45 [1.772]	16 [0.630]	20 [0.787]	20 [0.787]	21 [0.827]	25 [0.984]	45 [1.772]	45 [1.772]
CS□M	A Rod side	32 [1.260]	39 [1.535]	41 [1.614]	47 [1.850]	57 [2.244]	66 [2.598]	66 [2.598]	23 [0.906]	27 [1.063]	27 [1.063]	27 [1.063]	29 [1.142]	36 [1.417]	36 [1.417]
	B Rod side	16 [0.630]	20 [0.787]	20 [0.787]	21 [0.827]	25 [0.984]	44 [1.732]	44 [1.732]	16 [0.630]	20 [0.787]	20 [0.787]	21 [0.827]	25 [0.984]	44 [1.732]	44 [1.732]
CS□F	A Rod side	—	36 [1.417]	38 [1.496]	44 [1.732]	52 [2.047]	64 [2.520]	64 [2.520]	—	24 [0.945]	24 [0.945]	24 [0.945]	24 [0.945]	34 [1.339]	34 [1.339]
	B Rod side	—	17 [0.669]	17 [0.669]	18 [0.709]	20 [0.787]	42 [1.654]	42 [1.654]	—	17 [0.669]	17 [0.669]	18 [0.709]	22 [0.866]	42 [1.654]	42 [1.654]

SLIM CYLINDERS

## ● Push side stroke adjusting cylinder

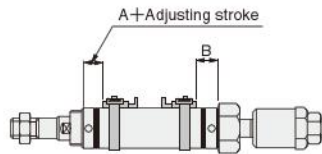

		mm [in.]			
Sensor switch model	Bore size Code	20 [0.787]	25 [0.984]	32 [1.260]	40 [1.575]
		ZG530□ ZG553□ CS□M	A	27 [1.063]	27 [1.063]
CS□F	B	27 [1.063]	27 [1.063]	27 [1.063]	27 [1.063]
	A	22 [0.866]	22 [0.866]	22 [0.866]	22 [0.866]
CS□F	B	22 [0.866]	22 [0.866]	22 [0.866]	22 [0.866]

## ● Pull side stroke adjusting cylinder

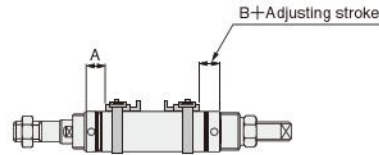

		mm [in.]			
Sensor switch model	Code	Bore size			
		20 [0.787]	25 [0.984]	32 [1.260]	40 [1.575]
ZG530□ ZG553□ CS□M	A	27 [1.063]	27 [1.063]	27 [1.063]	27 [1.063]
	B	37 [1.457]	37 [1.457]	42 [1.654]	42 [1.654]
CS□F	A	22 [0.866]	22 [0.866]	22 [0.866]	22 [0.866]
	B	32 [1.260]	32 [1.260]	37 [1.457]	37 [1.457]

## Moving Sensor Switch

- ZG530
- ZG553
- CS  M

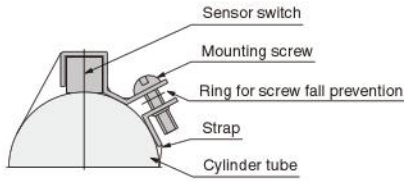

- Loosening the mounting screw allows the sensor switch to be moved freely along with the strap in the axial and circumferential direction. The sensor switch alone cannot be moved.
- To remove the sensor switch from the strap, first detach the strap from the cylinder tube and then remove the sensor switch from the strap.
- Tighten the mounting screw with a tightening torque of 49N·cm [4.3in·lbf].

- CS  F

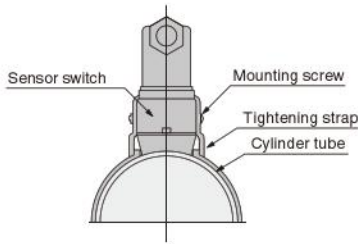

- Loosening the mounting screw allows the sensor switch to be moved freely in the axial and circumferential direction.
- Slightly loosening the mounting screw allows fine adjustment of the lead switch only, up to 5mm [0.2in.] in the axial direction. Tighten the mounting screw with a tightening torque of 68.6N·cm [6.1in·lbf].

## Dimensions of Sensor Switch (mm)

- ZG530
- ZG553
- CS  M

φ 16

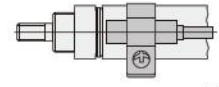
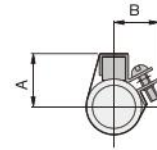

Lead wire length  
A: 1000mm [39in.]  
B: 3000mm [118in.]

φ 20 ~ φ 63

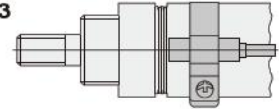
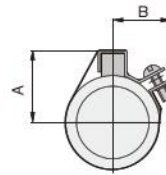

Lead wire length  
A: 1000mm [39in.]  
B: 3000mm [118in.]

		mm [in.]	
Bore	Code	A	B
16	[0.630]	16	15
20	[0.787]	19	17
25	[0.984]	20.5	17.5
32	[1.260]	25	19
40	[1.575]	29	—*
50	[1.969]	34	—*
63	[2.480]	41	—*

\* At φ 40 or larger, dimension B is the radius of the cylinder tube. Therefore, the protrusion in the B direction of the mounting section disappears.

- CS  F

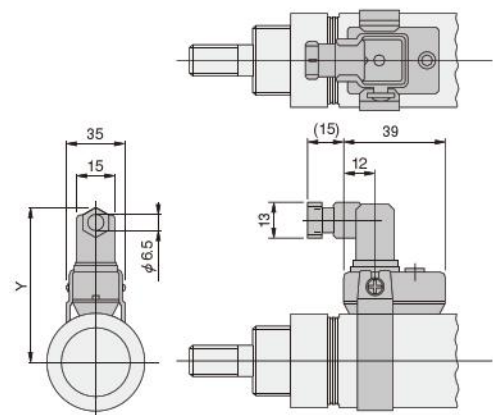

		mm [in.]
Bore	Code	Y
20	[0.787]	59
25	[0.984]	61.5
32	[1.260]	65
40	[1.575]	69
50	[1.969]	76
63	[2.480]	83

# ROD END ACCESSORIES

## Option

### Dimensions

#### ● $\phi 16$

#### ● Y type

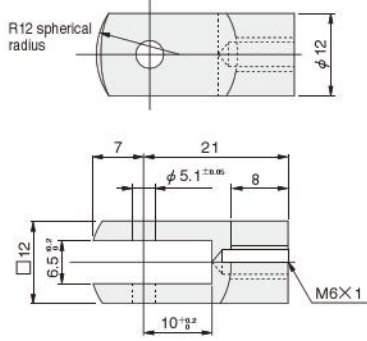

#### Pin for Y type knuckle

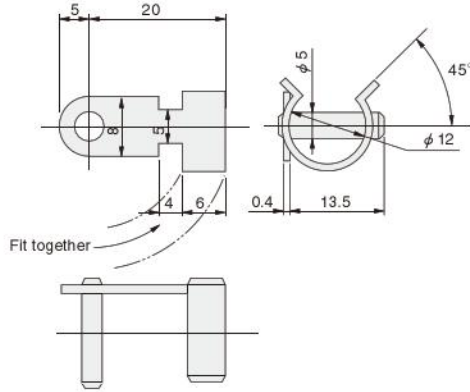

#### ● I type

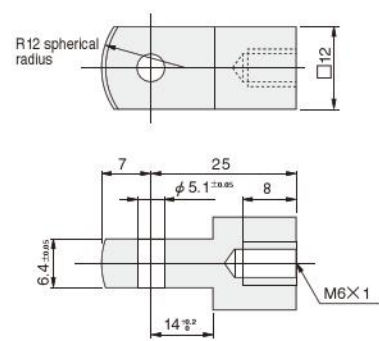

#### ● $\phi 20 \sim \phi 63$

#### ● Y type

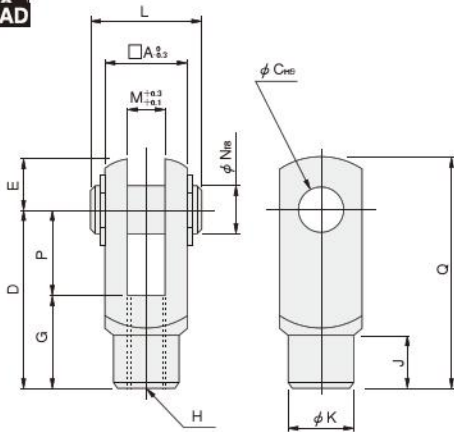

#### ● I type

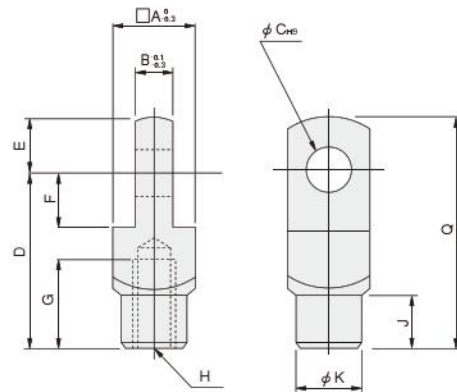

mm [in.]

Bore	Code	A	B	C	D	E	F	G	H	J	K	L	M	N	P	Q
20 [0.787], 25 [0.984]*		16	8	8	30	10	11	15	M8×1	10	14	21	8	8	15	40
25 [0.984], 32 [1.260]		19	10	10	40	12	13	20	M10×1.25	12	16	25	10	10	20	52
40 [1.575], 50 [1.969], 63 [2.480]		24	14	10	45	12	13	25	M14×1.5	15	22	30	14	10	20	57

Note: Items marked with ※ are for the square rod cylinders.

# BELLOWS, MOUNTING BRACKETS



## Dimensions (For brake cylinders with bellows, see p.367.)

### ● $\phi 20 \sim \phi 40$

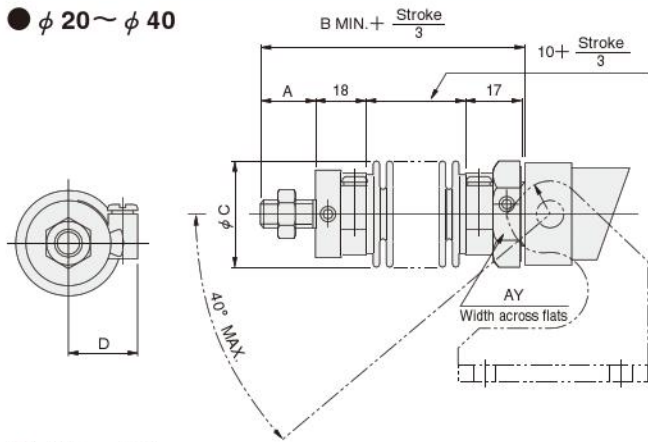

Bore	Code	A	B	C	D	AY
20	[0.787]	15 [0.591]	63 [2.480]	35 [1.378]	23 [0.906]	27 [1.063]
25	[0.984]	18 [0.709]	66 [2.598]	35 [1.378]	23 [0.906]	30 [1.181]
32	[1.260]	23 [0.906]	71 [2.795]	40 [1.575]	26 [1.024]	36 [1.417]
40	[1.575]	23 [0.906]	71 [2.795]	48 [1.890]	29 [1.142]	41 [1.614]

Note: Supporting brackets for the rod trunnion type with bellows should be mounted in the direction opposite to the case of no bellows shown in the diagram.

### ● $\phi 50, \phi 63$

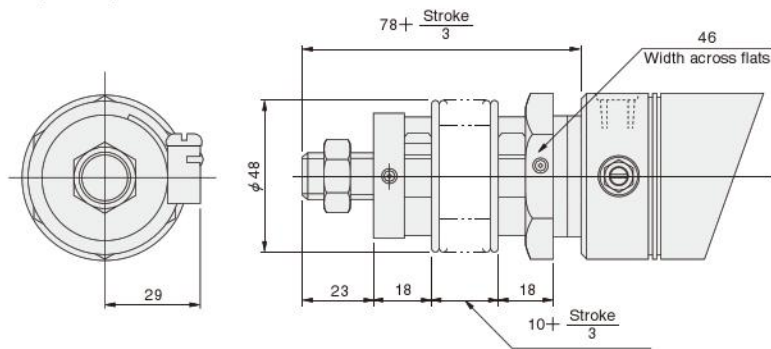

## Mass of Slim Cylinder with Bellows

Bore size mm [in.]	Zero stroke mass				Additional mass for each 1mm [0.0394in.] stroke
	Standard head	Short head	Pivot mounting type	Trunnion type	
20 [0.787]	0.25 [0.55] (0.23 [0.51])	0.24 [0.53] (0.22 [0.49])	—	0.44 [0.97]	0.0009 [0.0020]
25 [0.984]	0.29 [0.64] (0.27 [0.60])	0.28 [0.62] (0.26 [0.57])	—	0.47 [1.04]	0.0013 [0.0029]
32 [1.260]	0.43 [0.95] (0.40 [0.88])	0.41 [0.90] (0.38 [0.84])	—	0.60 [1.32]	0.0018 [0.0040]
40 [1.575]	0.62 [1.37] (0.56 [1.23])	0.58 [1.28] (0.52 [1.15])	—	0.78 [1.72]	0.0029 [0.0064]
50 [1.969]	1.03 [2.27]	0.98 [2.16]	0.95 [2.09]	—	0.0033 [0.0073]
63 [2.480]	1.36 [3.00]	1.32 [2.91]	1.29 [2.84]	—	0.0038 [0.0084]

Note: Figures in parentheses ( ) are for the cylinder with variable cushion.

# Order Codes for Mounting Bracket

## (1) Foot mounting bracket

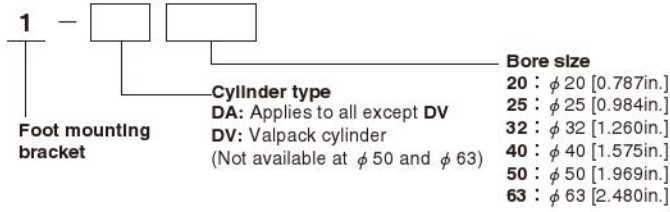

## (2) Flange mounting bracket

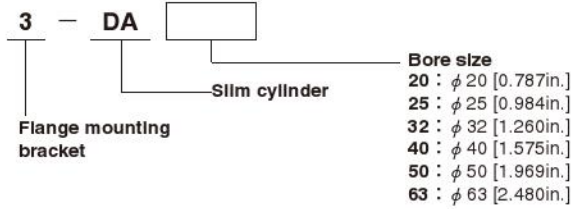

## (3) Pivot mounting type supporting bracket

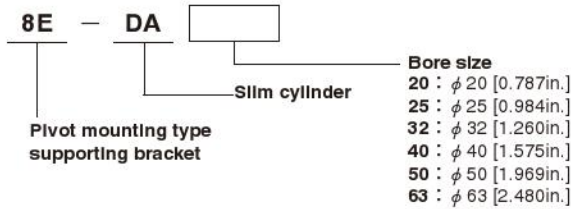

## (4) Head trunnion bracket

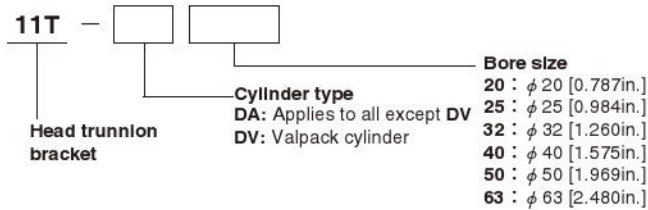

## (5) Rod trunnion bracket

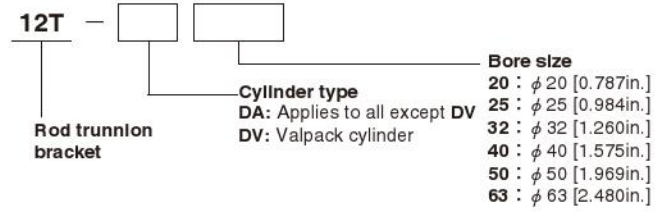

## (6) Y type knuckle

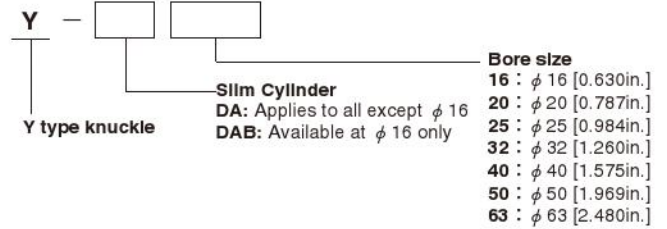

## (7) I type knuckle

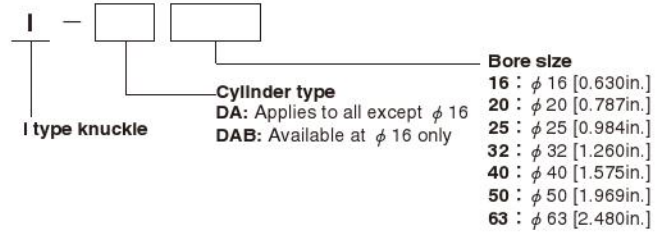

SLIM CYLINDERS