

SUPPLY JOINTS

- Although they have the same internal diameter and flow rate as steel pipes for piping, they occupy half of the piping space.
- With 44 types, 83 models, and an abundance of varieties, assembly can be done flexibly.
- Excellent durability and the nickel plating fits standard specifications.

Specifications

Media	Air
Maximum operating pressure	0.9 MPa [131 psi]
Operating vacuum pressure	-100 kPa [-29.5 inHg]
Operating temperature range	0~60°C [32~140°F]
Recommended tube	Nylon tube, urethane tube
Sales unit	1 pc.

Inner Construction, Major Parts and Materials

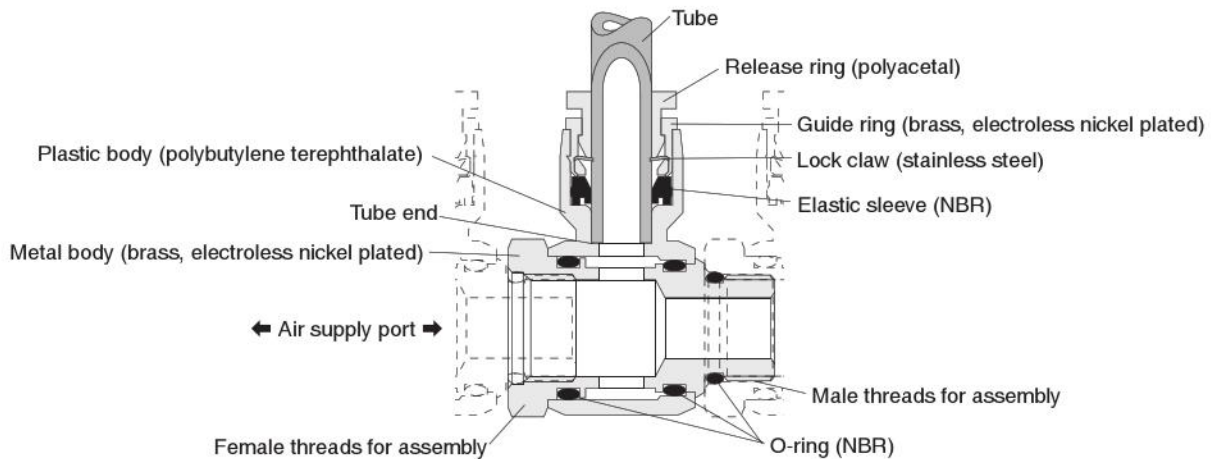

● SLB



Main side thread size	Sub-main side thread size (R)			
	1/8	1/4	3/8	1/2
M8×1 (8)	8-01	—	—	—
M12×1 (12)	12-01	12-02	—	—
M14×1 (14)	—	14-02	14-03	14-04
M18×1 (18)	—	—	18-03	18-04

Order codes

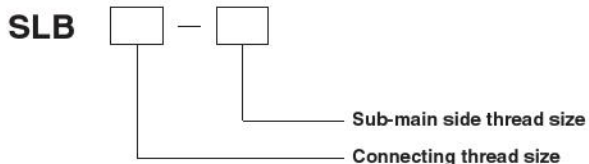

Dimensions mm

Elbow
SLB

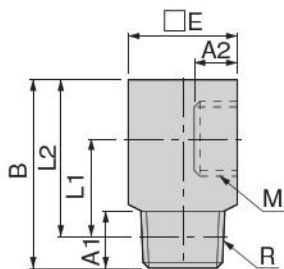

Model	R	M	A1	A2	B	L1 ^{Note}	L2 ^{Note}	E	Effective area mm ²	Mass g
SLB8-01	R1/8	M8×1	8	7	28	16	24	17	21.4	42
SLB12-01	R1/8	M12×1	8	8.5	29	15	25	19	24.5	48
SLB12-02	R1/4		11		32	16	26		40	50
SLB14-02	R1/4	M14×1	11	8.5	37	19	31	22	42.7	80
SLB14-03	R3/8		12		38	19.7	31.7		46	82
SLB14-04	R1/2		13		39	18.8	30.8			93
SLB18-03	R3/8	M18×1	12	9	44	23.7	37.7	27	49	141
SLB18-04	R1/2		13		45	22.8	36.8			157

Note: The L1 and L2 dimensions are the reference dimensions after the fittings are assembled.

● SLB



Main side thread size	Sub-main side thread size (R)			
	1/8	1/4	3/8	1/2
M8×1 (8)	8-01	—	—	—
M12×1 (12)	12-01	12-02	—	—
M14×1 (14)	—	14-02	14-03	14-04
M18×1 (18)	—	—	18-03	18-04

Order codes

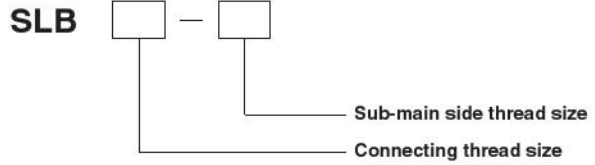

Dimensions in

Elbow
SLB

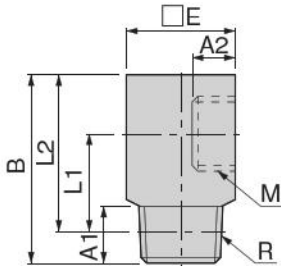

Model	R	M	A1	A2	B	L1 ^{Note}	L2 ^{Note}	□E	Effective area Cv	Mass oz
SLB8-01	R1/8	M8×1	0.315	0.276	1.102	0.630	0.945	0.669	394.830	1.482
SLB12-01	R1/8	M12×1	0.315	0.335	1.142	0.591	0.984	0.748	452.025	1.693
SLB12-02	R1/4		0.433		1.260	0.630	1.024		738.000	1.764
SLB14-02	R1/4	M14×1	0.433	0.335	1.457	0.748	1.220	0.866	787.815	2.822
SLB14-03	R3/8		0.472		1.496	0.776	1.248		848.700	2.892
SLB14-04	R1/2		0.512		1.535	0.740	1.213			3.280
SLB18-03	R3/8	M18×1	0.472	0.354	1.732	0.933	1.484	1.063	904.050	5.0
SLB18-04	R1/2		0.512		1.772	0.898	1.449			5.5

Note: The L1 and L2 dimensions are the reference dimensions after the fittings are assembled.

Safety Precautions (Supply Joints)

The safety precautions for supply joints are shown below. Be sure to read the material in the front of the General Personal Catalog regarding safety precautions other than those below.

⚠ WARNING

- Use only the rotary type quick fitting when using fittings in situations in which the threaded side or the tube side swings or rotates. Swinging and rotating may result in damage to the fitting itself.
- Use supports, such as brackets, when there is a large number of connections or when adding a bending load. Failing to do so may cause damages to the product or deformation in the mount mating surface.

Handling Instructions and Precautions

● Mounting

Precautions for mounting the body

- ① When mounting the fitting, use the appropriate tool to tighten the hex sockets or hex nuts on the fitting.
- ② Refer to the table of recommended tightening torques when tightening the threaded parts. If you use more than the recommended torque when tightening the screws, you may cause leaks by fracturing the threads or deforming the gaskets. If you use less than the recommended torque when tightening the threaded parts, it may result in looseness or leaks.
- ③ For products that cannot change their piping direction, adjust the threaded parts to within the tightening torque of the fitting after tightening them.

Recommended tightening torque, sealant color, and gasket material

Thread type	Thread size	Tightening torque	Sealant color	Gasket material
Metric thread	M3 × 0.5	0.7 N·m [6.196 in·lbf]	—	SUS304 NBR
	M5 × 0.8	1.0 to 1.5 N·m [8.851 to 13.277 in·lbf]		
	M6 × 1	1.8 to 2.3 N·m [15.932 to 20.357 in·lbf]		
	M8 × 1	3 to 5 N·m [26.553 to 44.255 in·lbf]		
	M12 × 1	5 to 10 N·m [44.255 to 88.510 in·lbf]		
	M14 × 1	10 to 20 N·m [88.510 to 177.020 in·lbf]		
Tapered threads for pipes	M18 × 1	10 to 20 N·m [88.510 to 177.020 in·lbf]	White	—
	R1/8	7 to 9 N·m [61.957 to 79.859 in·lbf]		
	R1/4	12 to 14 N·m [106.212 to 123.914 in·lbf]		
	R3/8	22 to 24 N·m [194.722 to 212.424 in·lbf]		
	R1/2	28 to 30 N·m [247.828 to 265.530 in·lbf]		

Precautions for disconnecting fittings

- ① When disconnecting fittings, use the appropriate tool to remove the hex sockets or hex nuts from the fitting.
- ② Remove the sealant from the threads on the other parts. If the sealant is stuck to the other parts, it may get into peripheral devices and cause a malfunction.

Tightening threaded parts

Use a wrench on the hex nut to tighten the threaded parts. (Refer to this document for details.)

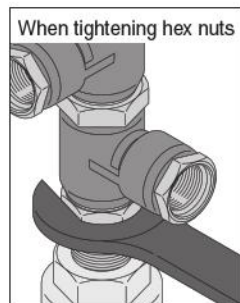

NOTE The sealant on the quick fittings can be reused multiple times, as is. However, the sealant may stick to the threaded parts of other devices. Be sure to clean the inside of the female threads on the devices.

⚠ CAUTION

- When connecting or disconnecting, use a wrench for main block assembly. Failing to do so may cause difficulty in assembly or deformation in the product.

● Attaching and detaching tubes

Precautions for attaching tubes

- ① Confirm that the cut surface of the tube is cut straight across, that the outer surface of the tube is not damaged, and that the tube has not become oval shaped.
- ② When connecting tubes, if you do not insert the tube all the way to the tube end, it may result in leaks.

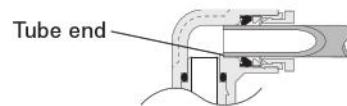

- ③ After installing the tube, pull on it to check that it does not come off.
- ④ Do not meaninglessly press on the release ring before attaching a tube. Doing so may cause the tube to become detached.

Precautions for removing tubes

- ① Before removing tubing, be sure to confirm that the pressure inside the tubing is zero.
- ② Uniformly press the release ring inwards as far as it goes and then pull out the tubing. If you do not fully press in on the release ring, the tube may not come out, or the tubing may become scratched causing debris to be left inside the fitting.

How to attach and detach tubes

① Attaching tubes

Main blocks, fitting type (quick fittings) are equipped with lock claws that hold tubes in place when they have been pushed all the way to the end, and with an elastic sleeve for sealing the periphery around the tubes.

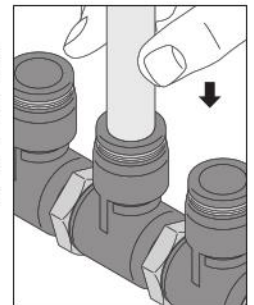

② Removing tubes

When removing a tube, pressing the release ring opens the lock claw and the tube can be pulled out. Be sure to stop the air before removing tubes.

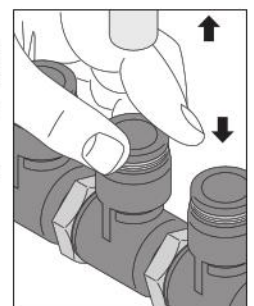

Handling Instructions and Precautions

If removing pipes is difficult because the piping space is very constricted, consult your nearest Koganei sales office for specialized tools that are available.

Specialized tools for removing tubes

For $\phi 3$ [0.118], $\phi 4$ [0.157], and $\phi 6$ [0.236] tubes
Order codes: **UJ-1**



For $\phi 6$ [0.236], $\phi 8$ [0.315], $\phi 10$ [0.394], and $\phi 12$ [0.472] tubes
Order codes: **UJ-2**



● Usable tubes

Use of both nylon tubing and urethane tubing are supported. Nylon tubing outside diameter precision should be within ± 0.1 mm [± 0.004 in] (nominal) for nylon tubing and within ± 0.15 mm [± 0.006 in] (nominal) for urethane tubing. Use tubing with ovality (difference between major axis and minor axis) within 0.2 mm [0.008 in]. (Use of Koganei tubing is recommended.)

Use of tubing that is not a Koganei genuine product or a compatible (recommended) product may result in tube disconnection, air leakage, or other problems. Be sure to check on tubing before building a pneumatic system.



1. Use tubing with an exterior that is not damaged. If tubing becomes damaged after repeated use, cut off the damaged portion.
2. Do not allow tubing to become severely bent or twisted near the connection to a fitting. Such a condition creates the risk of air leakage. The table below shows minimum radius guidelines for nylon and urethane tubing.
3. Do not use extremely soft tubing, which causes a severe drop in pull-out strength.
4. Before removing any tubes, always turn off the air supply. Also, be sure to confirm that the air inside the pipes is completely vented before starting.

mm [in]

Tube size	Minimum bending radius	
	Nylon tube	Urethane tube
$\phi 4$ [0.157]	20 [0.787]	10 [0.394]
$\phi 6$ [0.236]	30 [1.181]	15 [0.591]
$\phi 8$ [0.315]	50 [1.969]	20 [0.787]
$\phi 10$ [0.394]	80 [3.150]	27 [1.063]
$\phi 12$ [0.472]	150 [5.9]	35 [1.378]
$\phi 16$ [0.630]	500 [19.7]	—

Mounting Methods

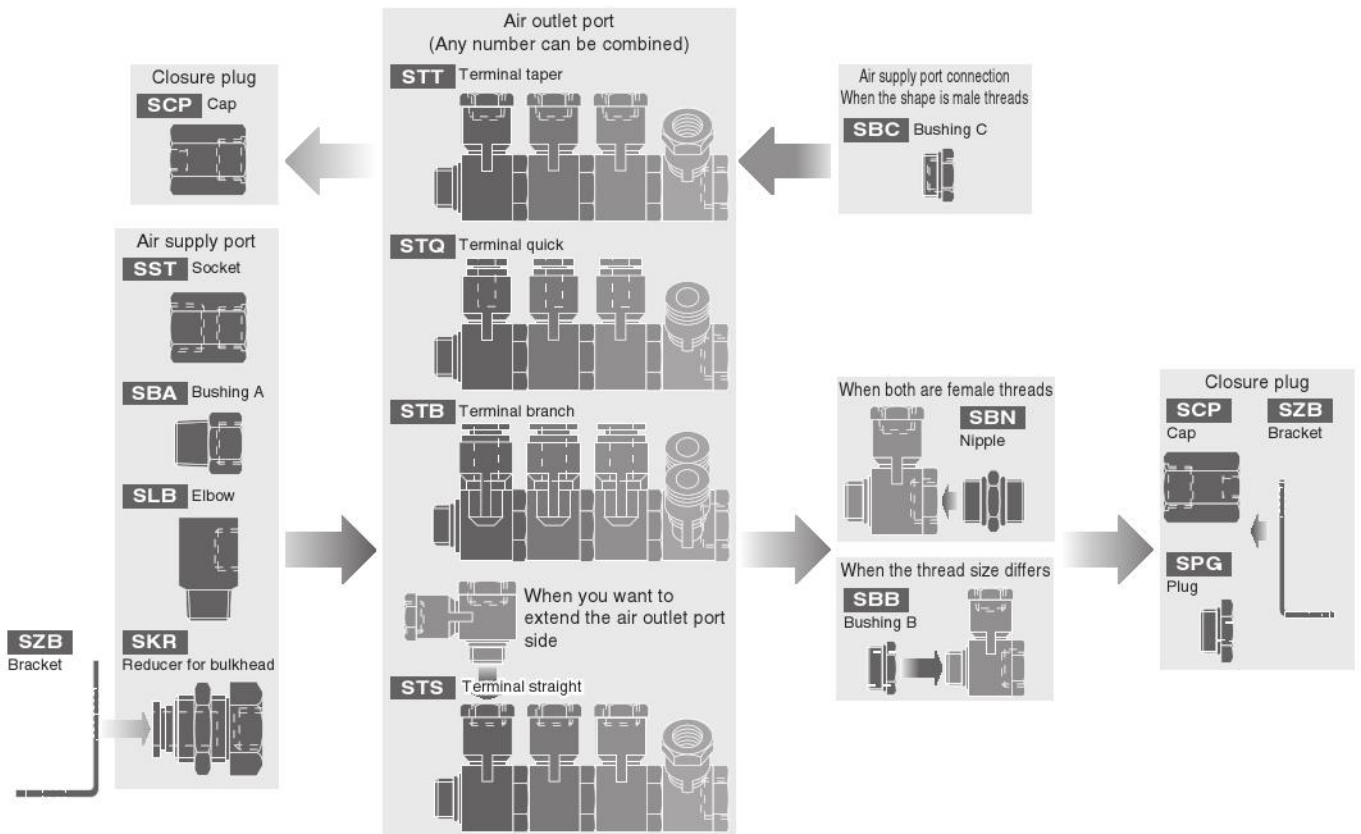

Codes shown in the above diagram: Because the S part of S□□ is a metric thread for assembly, it can be combined with threads of the same size.

- Air outlet port (3 types) Terminal quick (STQ), terminal branch (STB), and terminal taper (STT) (any number can be combined)
- Air supply port (5 types) Bushing A (SBA), elbow (SLB), bushing C (SBC), socket (SST), and reducer for bulkhead (SKR)
- Closure plug (2 types) Plug (SPG) and cap (SCP)
- When the thread size for assembly differs Bushing B (SBB)
- When both threads for assembly are female threads ... Nipple (SBN)
- Brackets for fixing Bracket (SZB)

Example of Piping

