

# More precision



We have added advanced positioning precision and high rigidity to the pneumatic actuator.

The Koganei Alpha Series further enhances the drive module concept, supporting superior applications and labor savings in FA line design and manufacturing with higher performance.

## Systematic Handling Module

*The handling module has mounting, turning, linear motion, positioning error correction, and gripping functions, which serve to shorten the design time regarding the material handling process, to reduce costs, and to deliver performance for the early set-up of automated lines.*

### Standardized modules

The handling operation is classified, standardized, and modularized into 7 functions.

As a result, designers can immediately complete the handling unit by combining modules organized by functions.

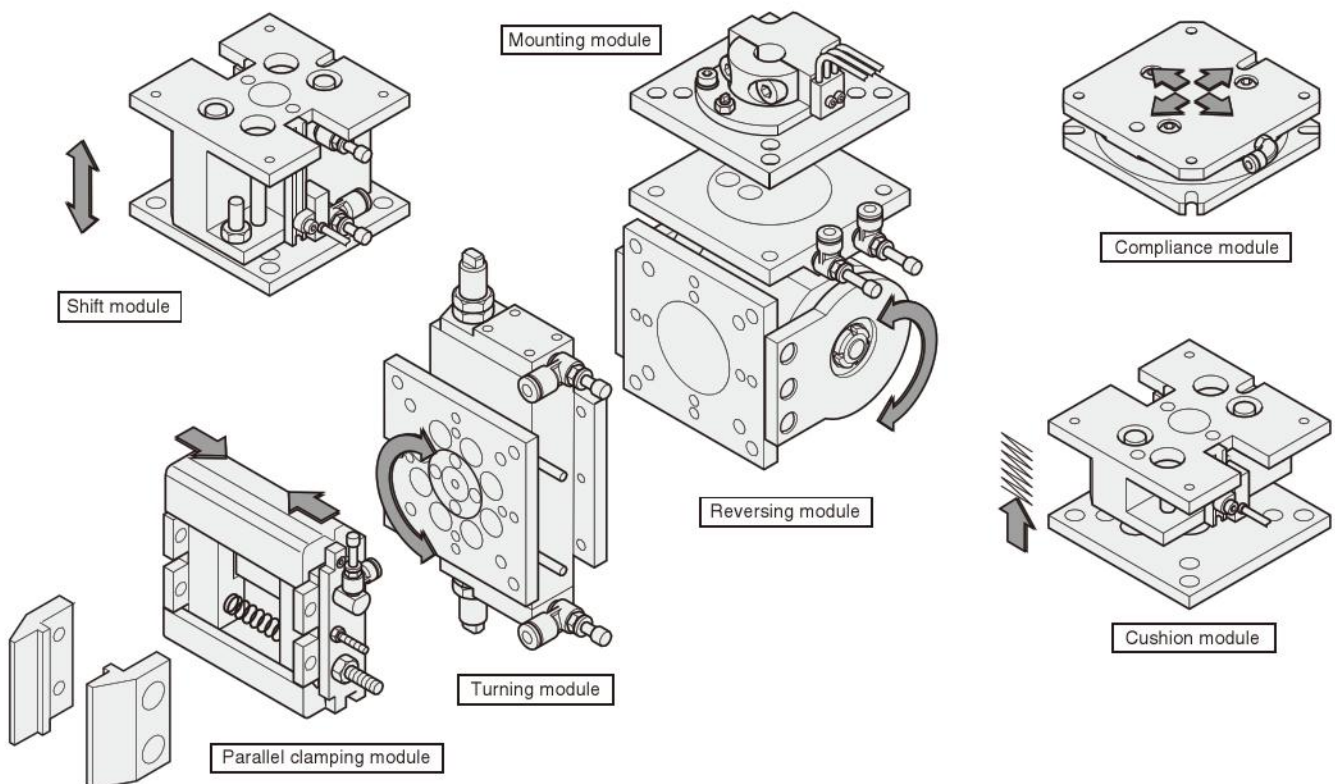

## Assure high accuracy

High machining and assembly precision of the module ensure high accuracy in single-unit use or combination use.

Repeatability in each module	
Turning module	$\pm 0.03^\circ$
Reversing module	$\pm 0.03^\circ$
Shift module	$\pm 0.05\text{mm}$ [ $\pm 0.0020\text{in.}$ ]
Cushion module	$\pm 0.05\text{mm}$ [ $\pm 0.0020\text{in.}$ ]
Compliance module	$\pm 0.02\text{mm}$ [ $\pm 0.0008\text{in.}$ ]
Parallel clamping module	$\pm 0.01\text{mm}$ [ $\pm 0.0004\text{in.}$ ]

- Tolerance of the contact surface parallelism between mounting surface and mounted surface  
=S : 0.04, M : 0.05, L : 0.06

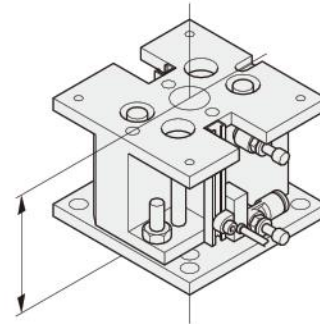

- Tolerance of the coaxiality with the hypothetical center, as restricted by the locating pin =S :  $\phi 0.04$ , M :  $\phi 0.05$ , L :  $\phi 0.06$

## Commonality of mounting pitch

### ● Full choice mounting method

The Systematic Handling Module is a standard module that provides handling operations in the precision assembly field by 7 classified functions, for a complete series. Moreover, the module uses the full choice mounting method that makes any combinations possible while keeping the excellent positioning accuracy.

#### Features

- ① Common mounting dimensions for each size
- ② Bottom surfaces can be used to mount the same size or one smaller sized module.
- ③ To ensure accurate positioning of the handling modules, there are dowel pin holes on contacted surface of each modules, and locating pins are available (2 locating pins supplied with each module, with the exception of the parallel clamping module).

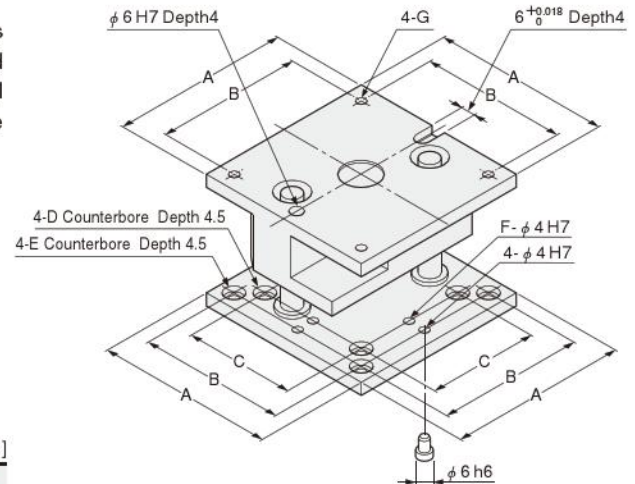

	mm [in.]						
	A	B	C	D	E	F	G
S size	60 [2.362]	50 [1.969]	—	—	M4	—	M4
M size	80 [3.150]	65 [2.559]	50 [1.969]	M4	M4	4 [0.157]	M5
L size	100 [3.937]	85 [3.346]	65 [2.559]	M4	M5		

## Optimum load mass

For the Systematic Handling Module, use the load masses shown below as a guide.

- S size ..... 250g [8.82oz.]
- M size ..... 500g [17.64oz.]
- L size ..... 1000g [35.27oz.]

- To calculate the maximum load mass, use the formula below.

Robot load capacity	—	Hypothetical mass with all connected modules	—	Load ratio	=	Load mass
S size : 3kg [6.6lb.] M size : 6kg [13.2lb.] L size : 9kg [19.8lb.]		S size : 1.5kg [3.3lb.] M size : 3kg [6.6lb.] L size : 5kg [11.0lb.]				S size : 250g [8.82oz.] M size : 500g [17.64oz.] L size : 1000g [35.27oz.]

The leading runner on the automated line, the Handling Module  
**This will be the STANDARD from now on.**

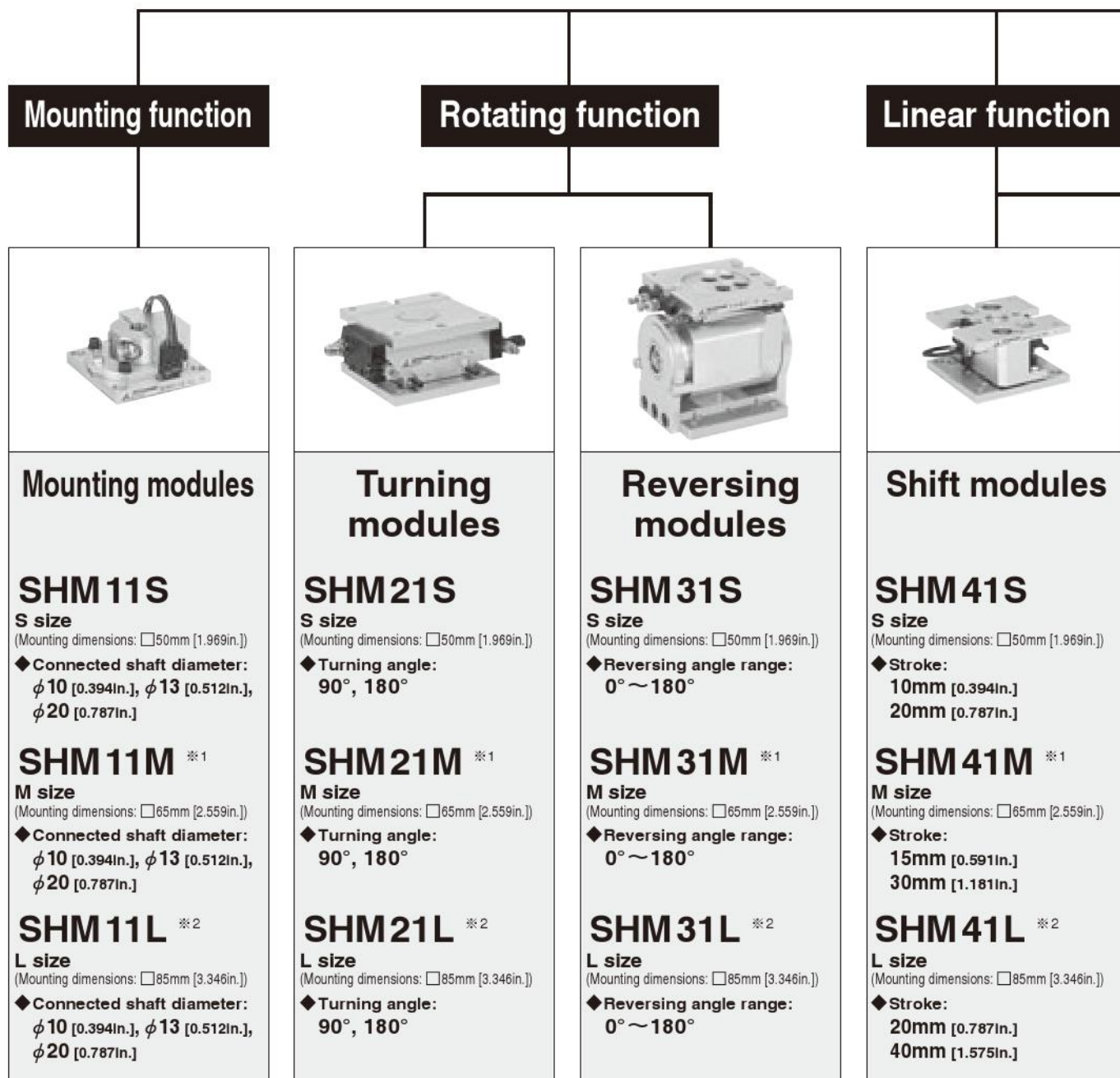

※1 : In addition to M size, S size mountings are also possible.

※2 : In addition to L size, M size mountings are also possible.

# Systematic HandlingModule

Positioning error correction function

Gripping function



## Cushion modules

### SHM51S

**S size**  
(Mounting dimensions: □50mm [1.969in.])

◆ **Stroke:**  
5mm [0.197in.]  
10mm [0.394in.]

### SHM51M <sup>※1</sup>

**M size**  
(Mounting dimensions: □65mm [2.559in.])

◆ **Stroke:**  
8mm [0.315in.]  
15mm [0.591in.]

### SHM51L <sup>※2</sup>

**L size**  
(Mounting dimensions: □85mm [3.346in.])

◆ **Stroke:**  
10mm [0.394in.]  
20mm [0.787in.]



## Compliance modules

### SHM61S, 62S

**S size**  
(Mounting dimensions: □50mm [1.969in.])

### SHM61M, 62M

**M size**  
(Mounting dimensions: □65mm [2.559in.])

### SHM61L, 62L

**L size**  
(Mounting dimensions: □85mm [3.346in.])



## Parallel clamping modules

### SHM71S

**S size**  
(Mounting dimensions: □50mm [1.969in.])

◆ **Gripping width:**  
42mm [1.65in.]

### SHM71M

**M size**  
(Mounting dimensions: □65mm [2.559in.])

◆ **Gripping width:**  
57mm [2.24in.]

### SHM71L

**L size**  
(Mounting dimensions: □85mm [3.346in.])

◆ **Gripping width:**  
73mm [2.87in.]



## Parallel clamping long modules

### SHM72S

**S size**  
(Mounting dimensions: □50mm [1.969in.])

◆ **Gripping width:**  
140, 240, 340mm  
[5.51, 9.45, 13.39in.]

### SHM72M

**M size**  
(Mounting dimensions: □65mm [2.559in.])

◆ **Gripping width:**  
176, 276, 376mm  
[6.93, 10.87, 14.80in.]

### SHM72L

**L size**  
(Mounting dimensions: □85mm [3.346in.])

◆ **Gripping width:**  
318, 418, 518mm  
[12.52, 16.46, 20.39in.]

● SHM62 is NZ specification.  
For details, see p.1521.



# Dimensions of SHM11S, M, L (mm)



SHM11 Mounting specification Connected shaft diameter

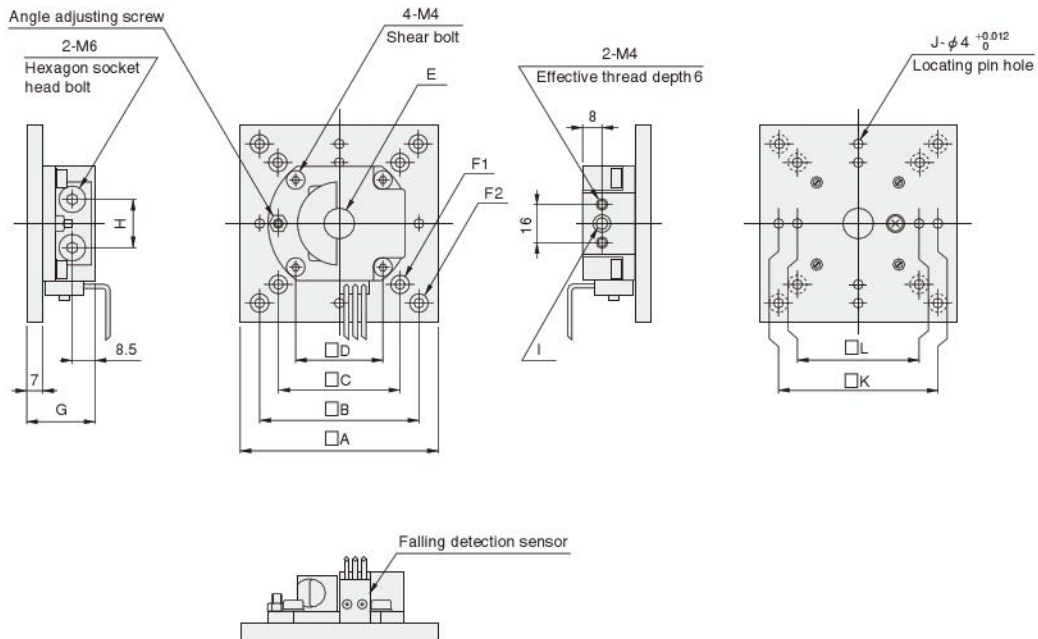

- Remarks: 1. Perpendicularity tolerance between the connected shaft center and mounted surface is 0.05.  
 2. Coaxiality tolerance between the hypothetical center and the mounted shaft center, as restricted by the locating pin = S :  $\phi$  0.04, M :  $\phi$  0.05, L :  $\phi$  0.06

Code Model	A	B	C	D	E	F1	F2	G	H	I	J	K	L
SHM11S-10	60	50	—	36	$\phi$ 10 <sup>+0.015/0</sup>	—	4- $\phi$ 4.5 4- $\phi$ 8 Counterbore Depth 4.4	28	20	$\phi$ 4 <sup>+0.012/0</sup> (Opening $\phi$ 6 Depth 10)	4	50 $\pm$ 0.03	—
SHM11S-13					$\phi$ 13 <sup>+0.018/0</sup>					$\phi$ 5 <sup>+0.012/0</sup> (Opening $\phi$ 6 Depth 10)			
SHM11S-20					$\phi$ 20 <sup>+0.021/0</sup>					$\phi$ 6 <sup>+0.012/0</sup>			
SHM11M-10	80	65	50	36	$\phi$ 10 <sup>+0.015/0</sup>	4- $\phi$ 4.5 4- $\phi$ 8 Counterbore Depth 4.4	28	20	$\phi$ 4 <sup>+0.012/0</sup> (Opening $\phi$ 6 Depth 10)	8	65 $\pm$ 0.03	50 $\pm$ 0.03	
SHM11M-13					$\phi$ 13 <sup>+0.018/0</sup>				$\phi$ 5 <sup>+0.012/0</sup> (Opening $\phi$ 6 Depth 10)				
SHM11M-20					$\phi$ 20 <sup>+0.021/0</sup>				$\phi$ 6 <sup>+0.012/0</sup>				
SHM11L-10	100	85	65	36	$\phi$ 10 <sup>+0.015/0</sup>	4- $\phi$ 5.5 4- $\phi$ 9.5 Counterbore Depth 3.5	28	20	$\phi$ 4 <sup>+0.012/0</sup> (Opening $\phi$ 6 Depth 10)	8	85 $\pm$ 0.05	65 $\pm$ 0.03	
SHM11L-13					$\phi$ 13 <sup>+0.018/0</sup>				$\phi$ 5 <sup>+0.012/0</sup> (Opening $\phi$ 6 Depth 10)				
SHM11L-20					$\phi$ 20 <sup>+0.021/0</sup>				$\phi$ 6 <sup>+0.012/0</sup>				

# TURNING MODULES

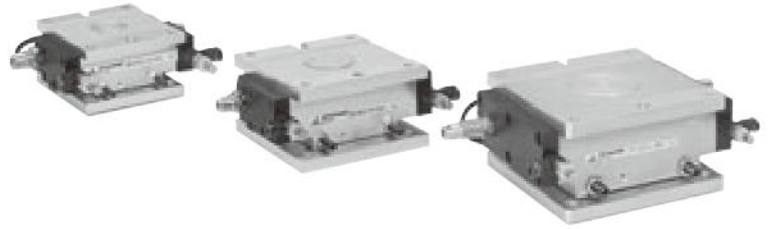

The module turns hand (gripper) units within ranges of  $-5^{\circ}$  to  $95^{\circ}$ , or  $-5^{\circ}$  to  $185^{\circ}$ .

## ● Locating pin

(Apply locking adhesive and insert it into the required hole.)

## ● Turning angle

The stopper and angle adjusting screw enable to set the turning angle anywhere within the range.

## ● Turning table

## ● Stopper

Note: Change the threaded location to align with the set turning angle. (Apply locking adhesive to tighten for locking.)

## ● Turning angle adjusting screw

Note: Although it is possible to use a turning angle adjusting screw for adjustment, always use a shock absorber at the swing end. Moreover, the range for turning angle adjustment is limited. For details, see p.1512.

## ● Main shaft

## ● Bearing

## ● Shock absorber

(Screw it in as far as the turning angle set position, and then return one-half rotation and secure it in place.)

## ● Speed controller with quick fitting

The turning speed can be adjusted. (Be aware to avoid exceeding the operating speed range.)

Note: Since loosening the connection screws will go out of the assembly precision, do not disassemble.

## Specifications

Item		Model	SHM 21S		SHM 21M		SHM 21L	
			NA	MA	NA	MA	NA	MA
Mounting specification	Mounting surface	S		M		L		
	Mounted surface	S		M or S <sup>Note1</sup>		L or M <sup>Note2</sup>		
Media			Air					
Operating pressure range MPa [psi.]			0.2~0.6 [29~87]					
Proof pressure MPa [psi.]			1 [145]					
Operating temperature range °C [°F]			0~60 [32~140]					
Operation type and mechanism			Double acting type, rack & pinion drive, with shock absorber <sup>Note3</sup> , with turning angle adjusting mechanism					
Lubrication			Not required					
Turning angle range <sup>Note4</sup>			$-5^{\circ}\sim 95^{\circ}$		$-5^{\circ}\sim 185^{\circ}$		$-5^{\circ}\sim 95^{\circ}$	
Effective torque <sup>Note5</sup> N·cm [in·lbf]			46.5 [4.1]		127.5 [11.3]		303 [26.8]	
Shock absorber			KSHA6 X5-D		KSHA6 X5-DE		KSHA6 X8-F	
Allowable energy J [ft·lbf]			0.67 [0.49]		1.03 [0.76]		2.06 [1.52]	
Allowable moment N·cm [in·lbf]			60 [5.3]		120 [10.6]		240 [21.2]	
Allowable thrust load N [lbf.]			60 [13.5]		130 [29.2]		200 [45.0]	
Turning angle repeatability			$\pm 0.03^{\circ}$					
Operating speed range Degrees/s			40~320					
Sensor switches			Operation detection X2					
Mass		g [oz.]	300 [10.6]	330 [11.6]	630 [22.2]	690 [24.3]	1300 [45.9]	1500 [52.9]

Notes: 1. Both M and S sizes can be mounted on SHM21M.  
 2. Both L and M sizes can be mounted on SHM21L.  
 3. Set the shock absorber at a one-half rotation returned position from the turning angle set position.  
 4. Use the stopper and angle adjusting screw to set the turning angle anywhere within the range.  
 5. Values at 0.5MPa [73psi.] air pressure.

## Order Codes

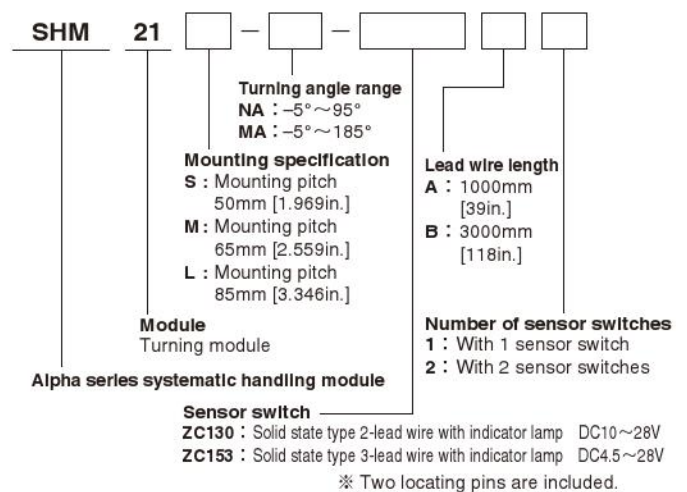

## Order codes for sensor switches only

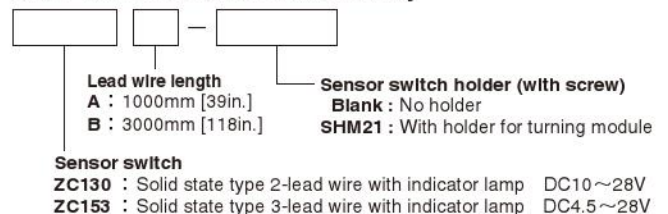

● For details of sensor switches, see p.1544.

# Dimensions of SHM21S, M, L (mm)

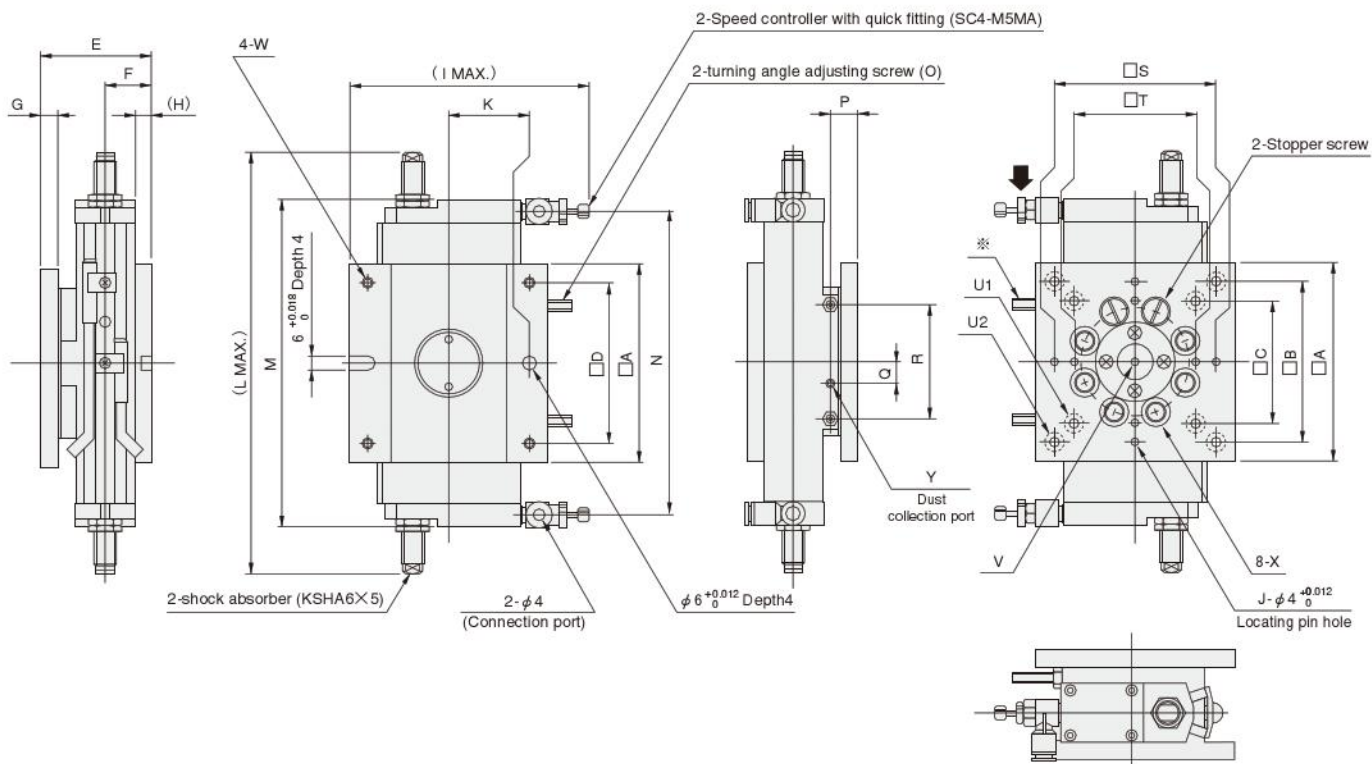
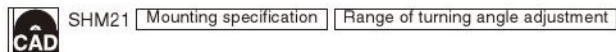

Remarks: 1. Tolerance of the contact surface parallelism between mounting surface and mounted surface = S : 0.04, M : 0.05, L : 0.06  
 2. Coaxiality tolerance between the hypothetical turning center, as restricted by the locating pin, and the actual turning center = S : φ 0.04, M : φ 0.05, L : φ 0.06

In the drawing above, air is supplied from the fitting marked arrow → to rotate the turning table in a counterclockwise direction and bring it into contact with the adjusting screw marked with ※ as the 0° state.

Code	A	B	C	D	E	F	G	H	I	J	K	L	M	N	O	P	Q	R	S	T	U1	U2	V	W	X	Y
Model																										
SHM21S-NA	60	50	—	50	35	14.5	6	5.5	83	4	25.0	110	79	70	M3	9.5	6	32	50±0.03	—	—	4-φ 4.5 4-φ 8 Counterbore Depth 4.4 (from the back side)	φ 3 +0.012 Depth 3	M4	M8×1	M3
SHM21S-MA												130	99	90												
SHM21M-NA	80	65	50	65	45	19.0	7	7.0	96	8	32.5	140	99	90	M4	11.5	8	46	65±0.03	50±0.03	4-φ 4.5 4-φ 8 Counterbore Depth 4.4 (from the back side)	φ 4 +0.012 Depth 3	M4	M8×1	M3	
SHM21M-MA												170	131	122												
SHM21L-NA	100	85	65	85	55	21.5	8	8.0	120	8	42.5	177	120	110	M6	15.0	10	58	85±0.05	65±0.03	4-φ 5.5 4-φ 9.5 Counterbore Depth 4.4 (from the back side)	φ 4 +0.012 Depth 3	M5	M10×1	M5	
SHM21L-MA												228	171	161												

## Allowable thrust load and allowable moment

Do not apply either the thrust load (W) or moment (M=F×L) exceeding the allowable values listed on p.1511.

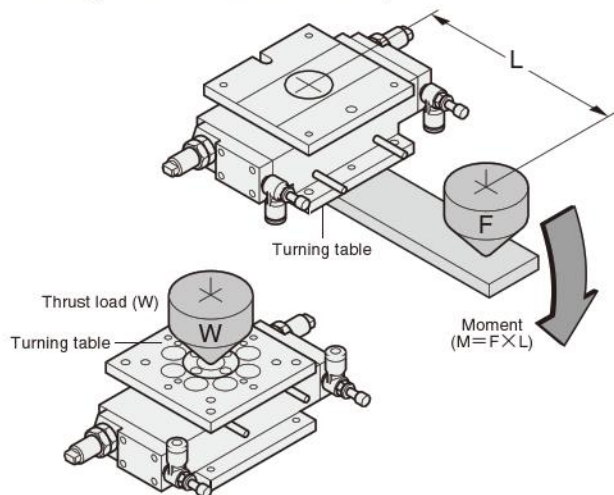

## Range of turning angle adjustment

### 180° turning angle MA type

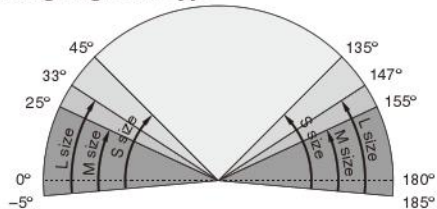

### 90° turning angle NA type

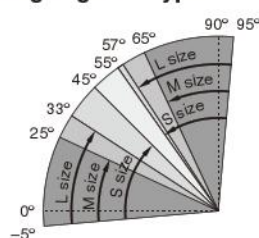

The arrows → show the range of turning angle adjustment by changing the shock absorbers' mounting positions. For adjustment other than that shown above, consult us.

# REVERSING MODULES



The module reverses the hand (gripper) unit within a range of 0° to 180°.

## ● Shock absorber

(Used also as the reversing angle adjusting screw.)  
Screw in the shock absorber up to the set reversing angle adjusting position.

## ● Angular bearing

(One bearing is arranged on each end)

## ● Reversing shaft

(Vane rod)

## ● Stopper

Change the screwed position to align with the set reversing angle.  
(Apply locking adhesive to tighten for locking.)

## ● Speed controller with quick fitting

The reversing speed can be adjusted.  
(Be aware to avoid exceeding the operating speed range.)

## ● Magnet holder

Loosening the M3 setscrew allows the plate to move in a circumferential direction.  
Adjust the mounting position so that the sensor switch operates at a required position.

## ● Reversing body

(Vane type rotary actuator)

Note: Since loosening the connection screws will go out of the assembly precision, do not disassemble.

## Specifications

Item		Model		
		SHM31S	SHM31M	SHM31L
Mounting specification	Mounting surface	S	M	L
	Mounted surface	S	M or S <sup>Note1</sup>	L or M <sup>Note2</sup>
Media		Air		
Operating pressure range		MPa [psi]		
Proof pressure		MPa [psi]		
Operating temperature range		°C [°F]		
Operation type and mechanism		Double acting type, vane drive, with shock absorber, with reversing angle adjusting mechanism		
Lubrication		Not required		
Reversing angle range		0°~180°		
Adjusting angle range		0°~180°		
Effective torque <sup>Note3</sup>		N·cm [in·lbf]		
Shock absorber		KSHAH6×3	KSHAH6×4	KSHAH6×5
Allowable moment		N·cm [in·lbf]		
Allowable energy		J [ft·lbf]		
Turning angle repeatability		±0.03°		
Operating speed range		Degrees/s		
Sensor switches		Operation detection×2		
Mass		g [oz.]		

Notes: 1. Both M and S sizes can be mounted on SHM31M.  
2. Both L and M sizes can be mounted on SHM31L.  
3. Values at 0.5MPa [73psi.] air pressure. The recommended torque for operation is about 50% of the effective torque.

## Order Codes

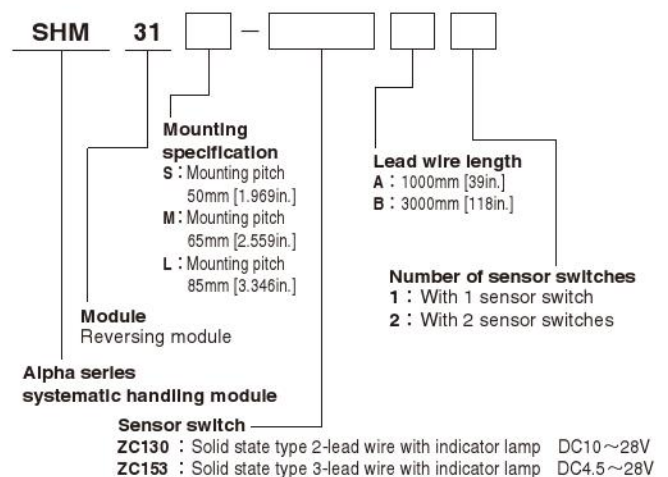

※ Two locating pins are included.

## Order codes for sensor switches only

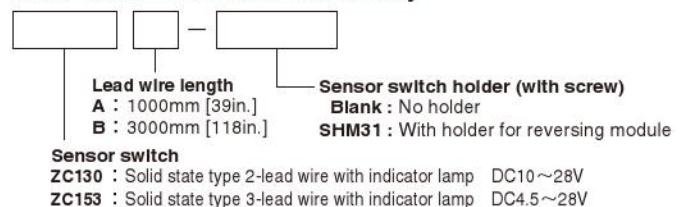

● For details of sensor switches, see p.1544.

# Dimensions of SHM31S, M, L (mm)

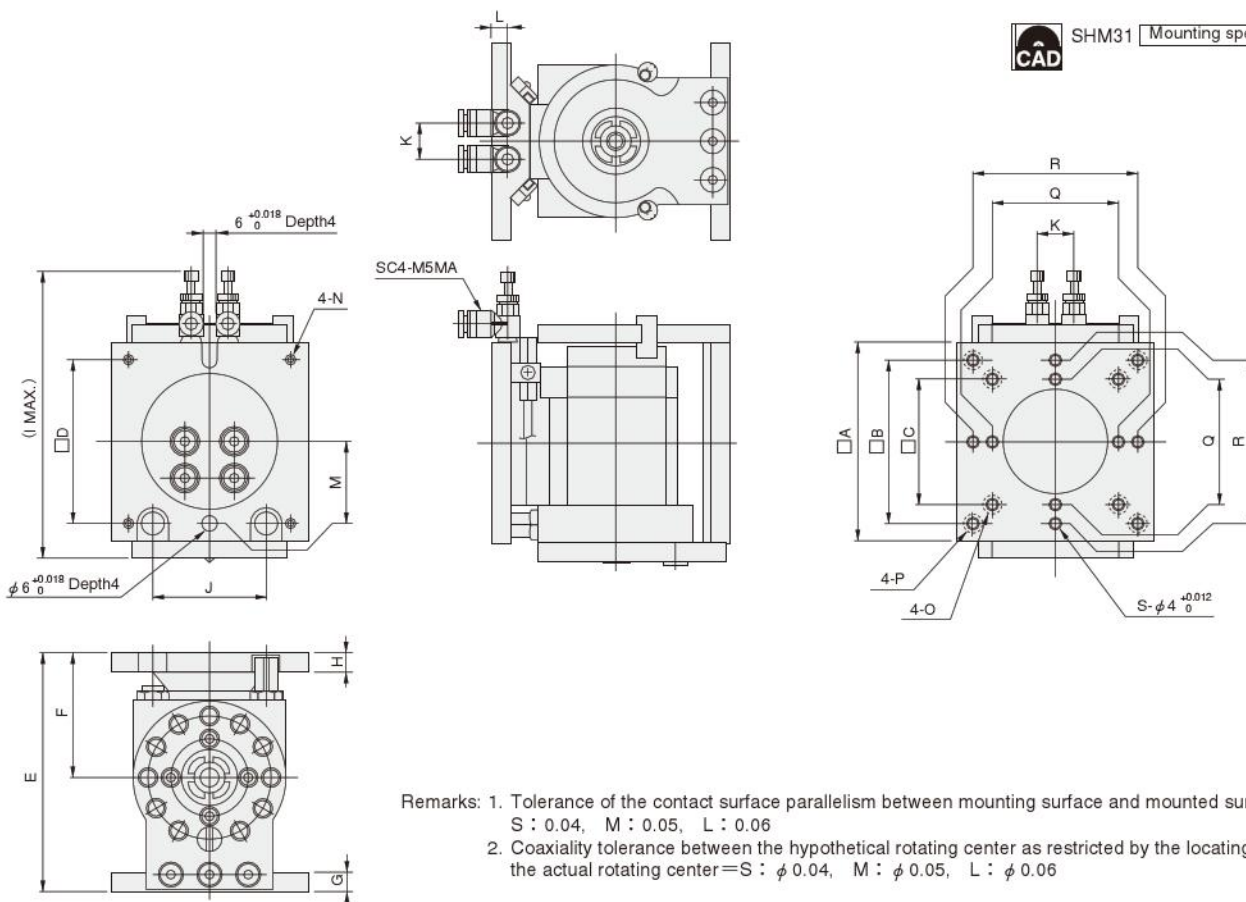

Remarks: 1. Tolerance of the contact surface parallelism between mounting surface and mounted surface = S : 0.04, M : 0.05, L : 0.06  
 2. Coaxiality tolerance between the hypothetical rotating center as restricted by the locating pin and the actual rotating center = S : φ 0.04, M : φ 0.05, L : φ 0.06

Code	A	B	C	D	E	F	G	H	I	J	K	L	M	N	O	P	Q	R	S
SHM31S	60	50	—	50	75	40	6	6	96	29	13	7	25.0	M4	—	φ4.5, φ8 Counterbore Depth 4.5	—	50±0.03	4
SHM31M	80	65	50	65	95	50	7	7	117	46	15	7	32.5	M4	φ4.5, φ8 Counterbore Depth 4.4	φ4.5, φ8 Counterbore Depth 4.5	50±0.03	65±0.03	8
SHM31L	100	85	65	85	115	60	8	8	138	51	20	7	42.5	M5	φ4.5, φ8 Counterbore Depth 4.4	φ5.5, φ9.5 Counterbore Depth 5.4	65±0.03	85±0.05	8

## Internal Capacity and Air Consumption

Internal capacity

- SHM31S : 9cm<sup>3</sup> [0.55in.<sup>3</sup>]
- SHM31M : 43cm<sup>3</sup> [2.62in.<sup>3</sup>]
- SHM31L : 75cm<sup>3</sup> [4.58in.<sup>3</sup>]

$$\text{Air consumption } Q = v \cdot \frac{(P_1 + 1.033)}{1.033} \cdot n$$

Q : Air consumption cc (cm<sup>3</sup>)/min (ANR)  
 v : Internal capacity of reversing module cc (cm<sup>3</sup>)  
 n : Operating frequency times/min  
 P<sub>1</sub> : Pressure kgf/cm<sup>2</sup>

$$\text{Air consumption } Q' = v' \cdot \frac{(P'_1 + 14.696)}{14.696} \cdot n$$

Q' : Air consumption in.<sup>3</sup>/min. (ANR)\*\*  
 v' : Internal capacity of reversing module in.<sup>3</sup>  
 n : Operating frequency times/min.  
 P'<sub>1</sub> : Pressure psi.

\*\*Refer to p.54 for an explanation of ANR.

## Allowable Moment

Do not apply the moment (M=F×L) exceeding the allowable values listed on p.1513.

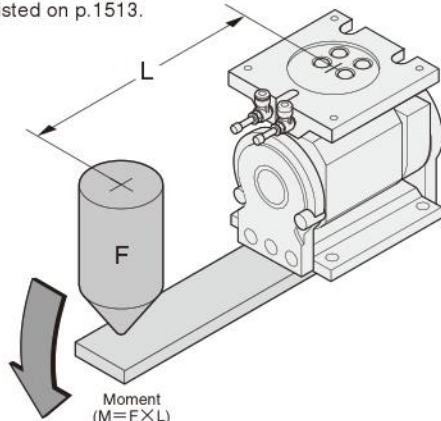

## Mounting Sensor Switch

Mount the sensor switch laterally in the sensor holder so that the model marking surface faces upward, as shown below.

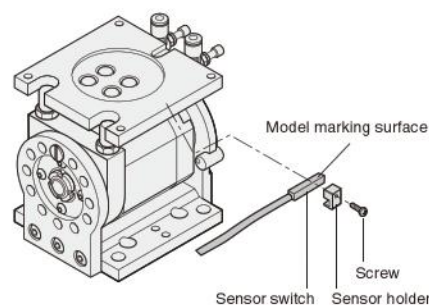

# SHIFT MODULES



The module to shift the vertical position of the hand (gripper) unit within a predetermined range. Suitable for constant-force insertion. Can also be used as a lifter.

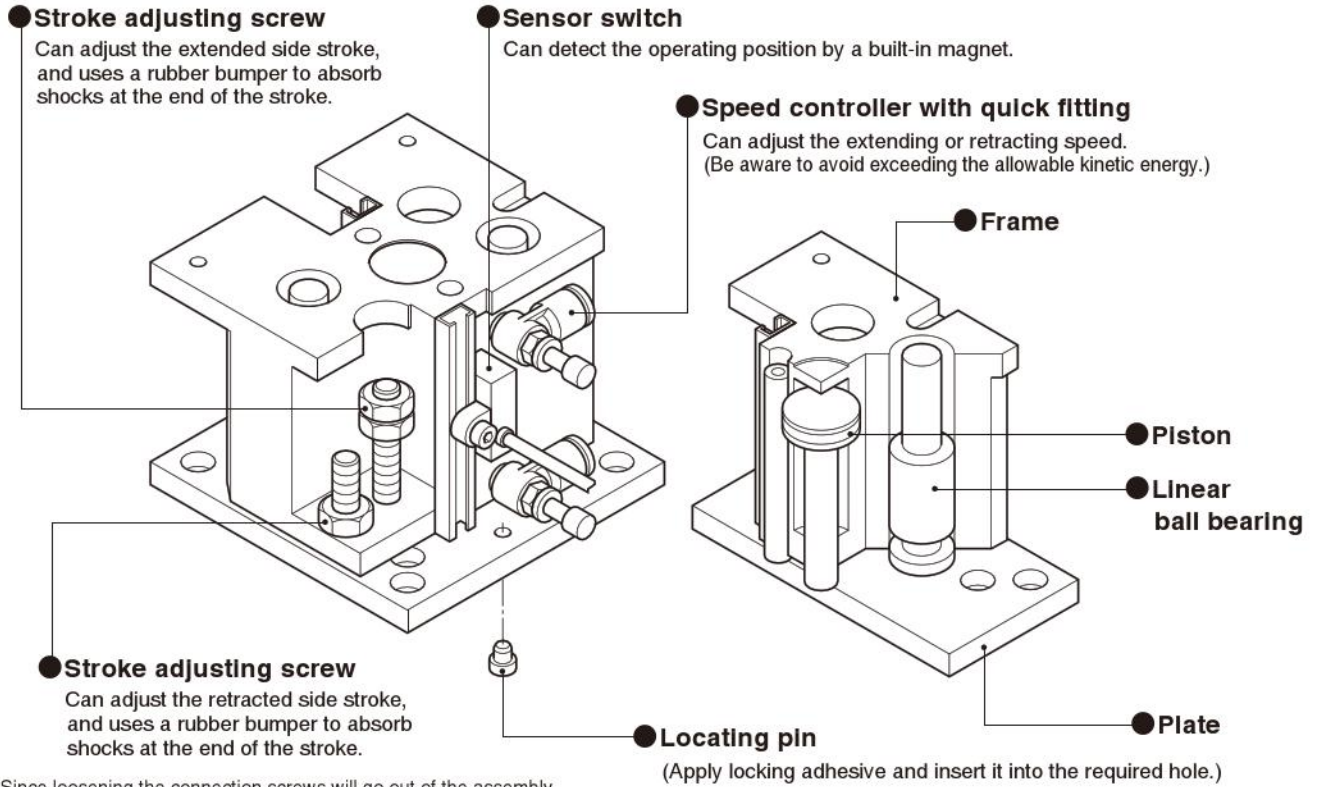

Note: Since loosening the connection screws will go out of the assembly precision, do not disassemble.

## Specifications

Model		SHM41S		SHM41M		SHM41L	
		MS	LS	MS	LS	MS	LS
Mounting specification	Mounting surface	S		M		L	
	Mounted surface	S		M or S <sup>Note1</sup>		L or M <sup>Note2</sup>	
Cylinder bore size	mm [in.]	12 [0.472]		16 [0.630]		20 [0.787]	
Stroke	mm [in.]	10 [0.394]	20 [0.787]	15 [0.591]	30 [1.181]	20 [0.787]	40 [1.575]
Media		Air					
Operating pressure range	MPa [psi.]	0.2~0.6 [29~87]					
Proof pressure	MPa [psi.]	1 [145]					
Operating temperature range	°C [°F]	0~60 [32~140]					
Operation type and mechanism		Double acting type, linear ball bearing, with stroke adjusting mechanism (bumper)					
Lubrication		Not required					
Cylinder thrust <sup>Notes</sup>	Extended side	56.5 [12.7]		100.5 [22.6]		157.1 [35.3]	
	Retracted side	42.4 [9.5]		86.4 [19.4]		131.9 [29.7]	
Allowable kinetic energy	J [ft·lbf]	0.03 [0.02]		0.06 [0.04]		0.08 [0.06]	
Allowable moment	N·cm [in·lbf]	30 [2.7]		40 [3.5]		80 [7.1]	
Operating speed range	mm/s [in./sec.]	30~300 [1.2~11.8]					
Repeatability	mm [in.]	±0.05 [±0.0020]					
Sensor switches		Operation detection X2					
Mass	g [oz.]	280 [9.9]	320 [11.3]	480 [16.9]	550 [19.4]	790 [27.9]	980 [34.6]

Notes: 1. Both M and S sizes can be mounted on SHM41M.  
2. Both L and M sizes can be mounted on SHM41L.  
3. Values at 0.5MPa [73psi.] air pressure.

## Order Codes

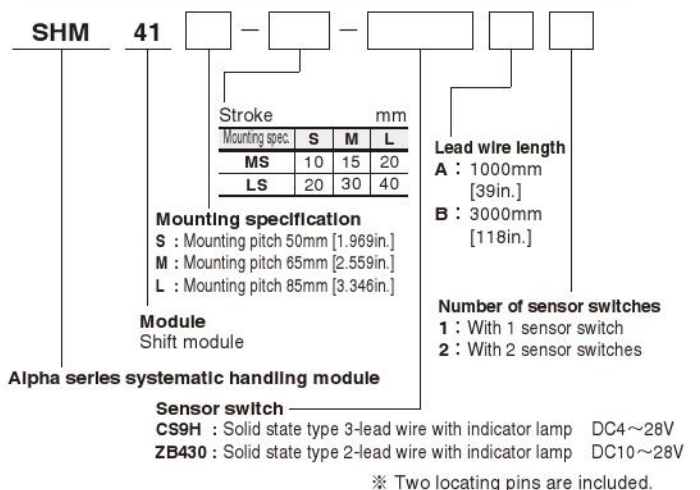

### Order codes for sensor switches only (with holder)

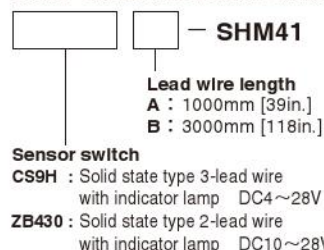

● For details of sensor switches, see p.1544.

# Dimensions of SHM41S, M, L (mm)

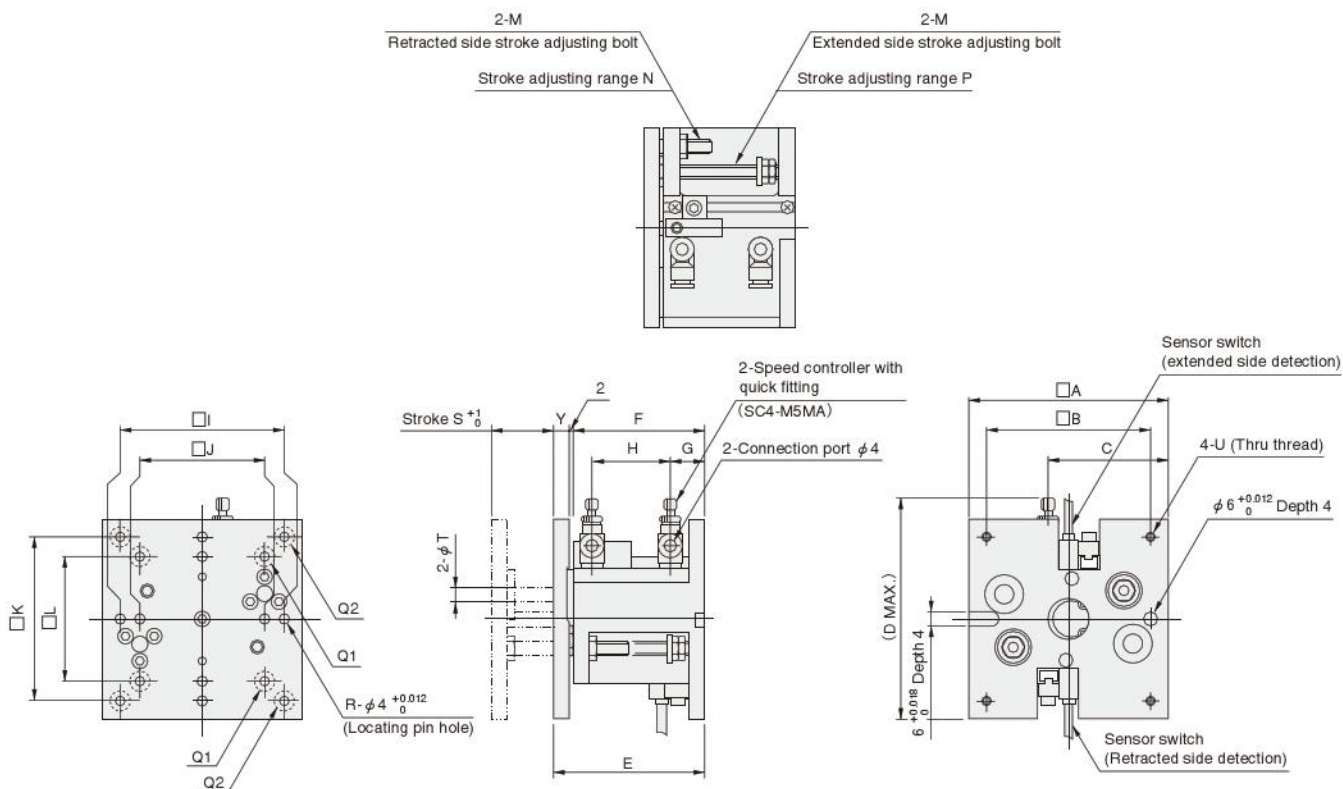

Remarks: 1. Tolerance of the contact surface parallelism between mounting surface and mounted surface = S : 0.04, M : 0.05, L : 0.06  
2. Coaxiality tolerance with the rotating center, as restricted by the locating pin = S :  $\phi$  0.04, M :  $\phi$  0.05, L :  $\phi$  0.06

Code	A	B	C	D	E	F	G	H	I	J	K	L	M	N	P <sup>Note</sup>	Q1	Q2	R	S	T	U	X	Y
SHM41S-MS	60	50	37	78	35	27	12	10.5	$50 \pm 0.03$	—	50	—	M4	2	10	—	4- $\phi$ 4.5 4- $\phi$ 8 Counterbore Depth 4.4	4	10	8	3	6	
SHM41S-LS					45	37		20.5						5	20			20			12		
SHM41M-MS	80	65	48	88	45	37	13	16.5	$65 \pm 0.03$	$50 \pm 0.03$	65	50	M5	5	15	4- $\phi$ 4.5 4- $\phi$ 8 Counterbore Depth 4.4	8	15	8	7	6		
SHM41M-LS					60	52		31.5						9	30			30			24		
SHM41L-MS	100	85	59	102	50	41	15	18.7	$85 \pm 0.05$	$65 \pm 0.03$	85	65	M6	3	20	(from the back side)	4- $\phi$ 5.5 4- $\phi$ 9.5 Counterbore Depth 5.4 (from the back side)	8	20	10	15	7	
SHM41L-LS					70	61		38.7						7	40			40			26		

Note: The sensor moving range, however, is Xmm beyond the end of extended side stroke.

## Allowable Moment

Do not apply the moment ( $M = F \times L$ ) exceeding the allowable values listed on p.1515.

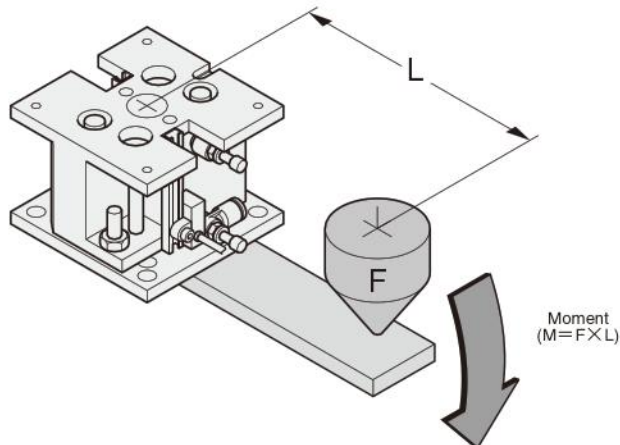

# CUSHION MODULES

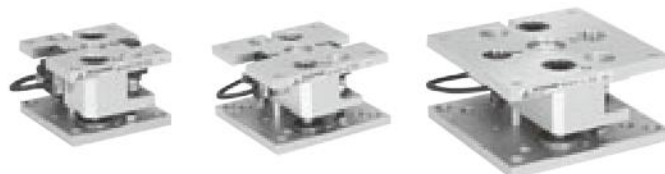

The module for protecting the workpieces. Can use an adjustable spring force for snap insertions.

## Stroke adjusting screw

Can adjust the extended side stroke, and uses a rubber bumper to absorb shocks at the end of the stroke.

## Sensor switch

Can detect the operating position by a built-in magnet.

## Cushion force adjusting mechanism

By detaching the snap ring and changing the cover position, the cushioning force can be adjusted in 4 levels.

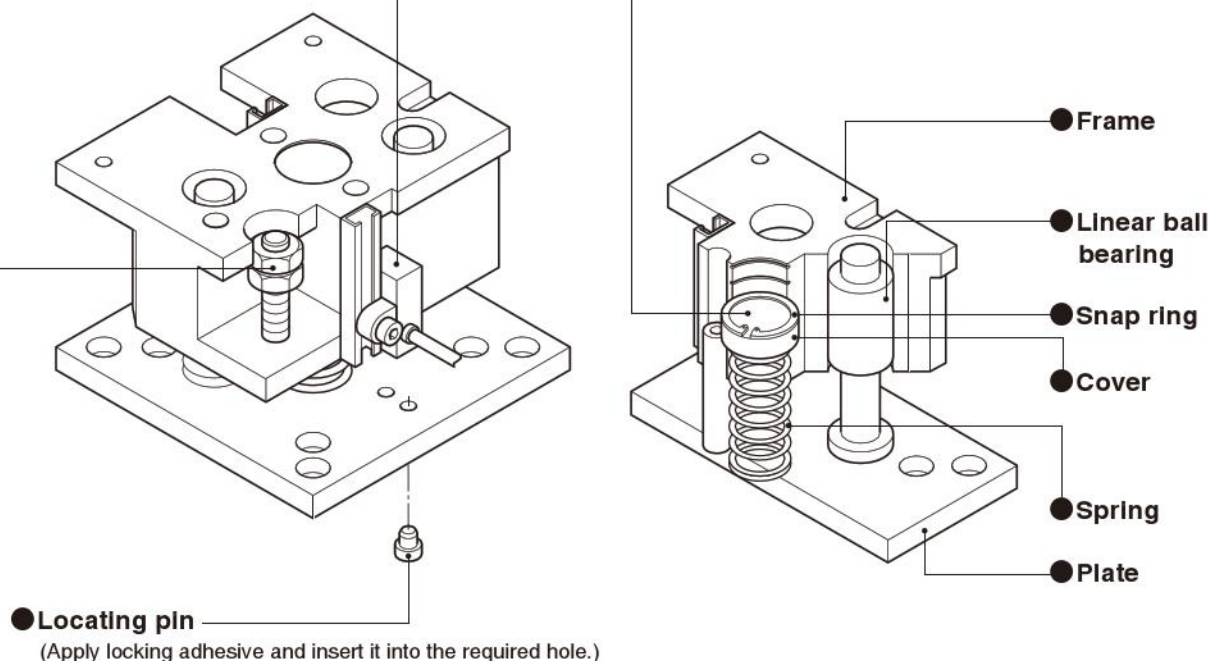

## Locating pin

(Apply locking adhesive and insert it into the required hole.)

Note: Since loosening the connection screws will go out of the assembly precision, do not disassemble.

## Specifications

Item		Model		SHM51S		SHM51M		SHM51L	
		SS	MS	SS	MS	SS	MS		
Mounting specification	Mounting surface	S		M		L			
	Mounted surface	S		M or S <sup>Note1</sup>		L or M <sup>Note2</sup>			
Stroke	mm [in.]	5 [0.197]	10 [0.394]	8 [0.315]	15 [0.591]	10 [0.394]	20 [0.787]		
Operating temperature range		°C [°F]		0~60 [32~140]					
Operation type and mechanism		Spring return, linear ball bearing, with stroke adjusting mechanism (bumper)							
Lubrication		Not required							
Cylinder thrust N [lbf.]	Extended side	3~12 [0.7~2.7]		4~16 [0.9~3.6]		4~16 [0.9~3.6]			
	Retracted side	—		—		—			
Allowable moment		N·cm [in·lbf]		30 [2.7]		40 [3.5]		80 [7.1]	
Repeatability		mm [in.]		±0.05 [±0.0020]					
Sensor switches		Operation detection X2							
Mass	g [oz.]	250 [8.8]	280 [9.9]	380 [13.4]	430 [15.2]	720 [25.4]	810 [28.6]		

Notes 1: Both M and S sizes can be mounted on SHM51M.  
2: Both L and M sizes can be mounted on SHM51L.

## Order Codes

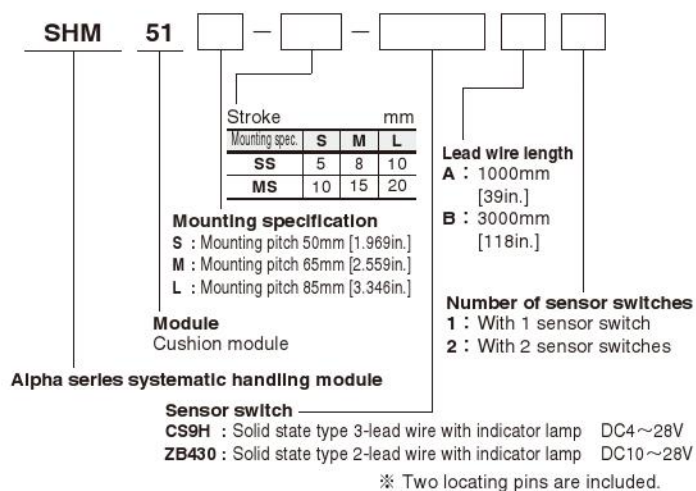

## Order codes for sensor switches only (with holder)

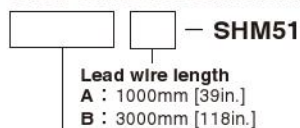

**Sensor switch**  
CS9H : Solid state type 3-lead wire with indicator lamp DC4~28V  
ZB430 : Solid state type 2-lead wire with indicator lamp DC10~28V

● For details of sensor switches, see p.1544.

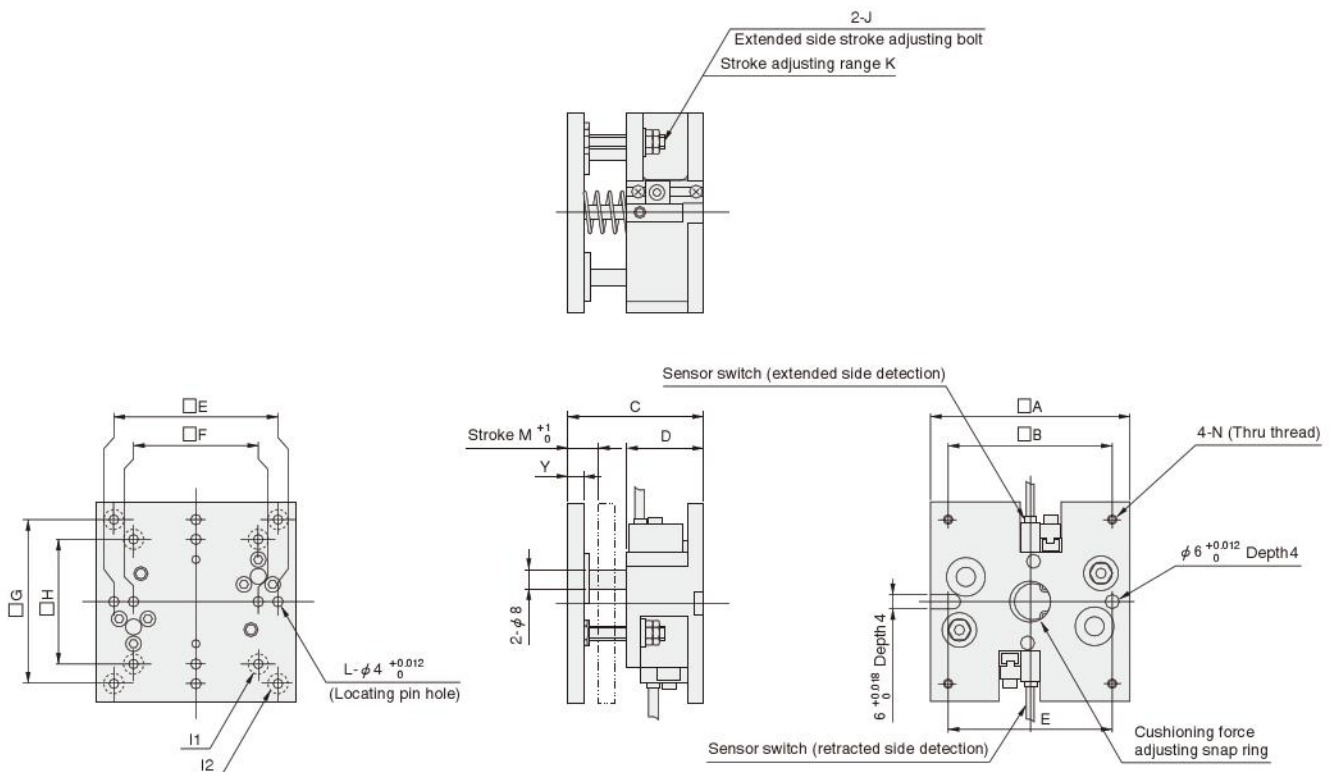

Remarks: 1. Tolerance of the contact surface parallelism between mounting surface and mounted surface = S : 0.04, M : 0.05, L : 0.06  
 2. Coaxiality tolerance with the rotating center, as restricted by the locating pin = S : φ 0.04, M : φ 0.05, L : φ 0.06

Model	Code	A	B	C	D	E	F	G	H	I1	I2	J	K <sup>Note</sup>	L	M	N	X		Y
																	Extended side	Retracted side	
SHM51S-SS	60	50	40	27	50±0.03	—	50	—	—	—	4-φ 4.5 4-φ 8 Counterbore Depth 4.4 (from the back side)	M4	5	4	5	M4	1	3	6
SHM51S-MS			45	27									10		10		3	4	
SHM51M-SS	80	65	45	28	65±0.03	50±0.03	65	50	4-φ 4.5 4-φ 8 Counterbore Depth 4.4	—	4-φ 5.5 4-φ 9.5 Counterbore Depth 5.4 (from the back side)	M5	8	8	8	M5	4	1	6
SHM51M-MS			55	31									15		15		7	5	
SHM51L-SS	100	85	50	31	85±0.05	65±0.03	85	65	—	—	—	M5	10	8	10	M5	5	2	7
SHM51L-MS			70	41									20		20		15	7	

Note: The sensor moving range, however, is Xmm.

### Allowable Moment

Do not apply the moment ( $M=F \times L$ ) exceeding the allowable values listed on p.1517.

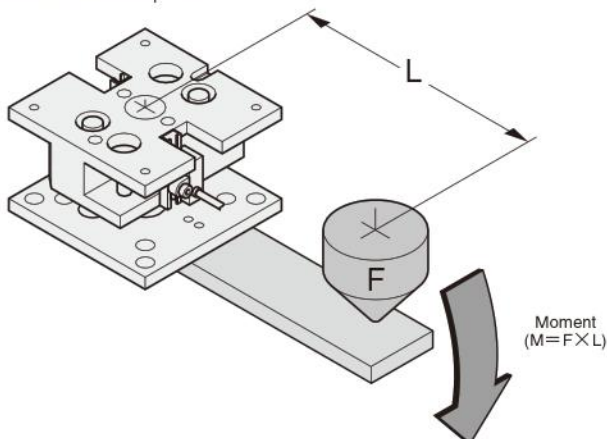

### Application Examples

Positioning error correction during clamping of irregularly shaped workpiece

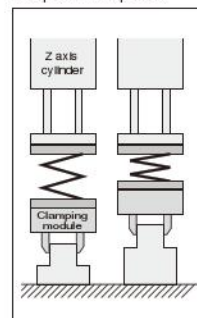

Protects the robot by correcting errors in the height.

Constant force insertion of plastic workpieces, etc. (snap insertion)

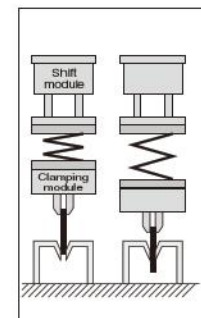

The cylinder inserts the workpiece up to a certain point, after which the spring force provides constant force insertion.

Detection of abnormalities of workpiece shape

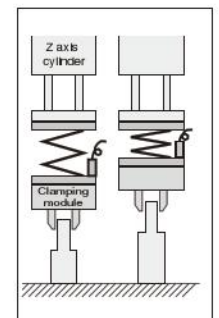

Uses sensor to detect abnormalities in the height, and removes abnormal workpieces only.

# COMPLIANCE MODULES



**Positioning error correction module with excellent response and repeatability.**  
**Comes mounted with a locking mechanism.**

## Operation principles

1. The frame and plate enclose rolling steel balls, which move freely under the light centripetal force of the restraining ring and spring.
2. Applying air pressure pushes the inner plate down, to lock it into the determined reference position with the locating steel ball.

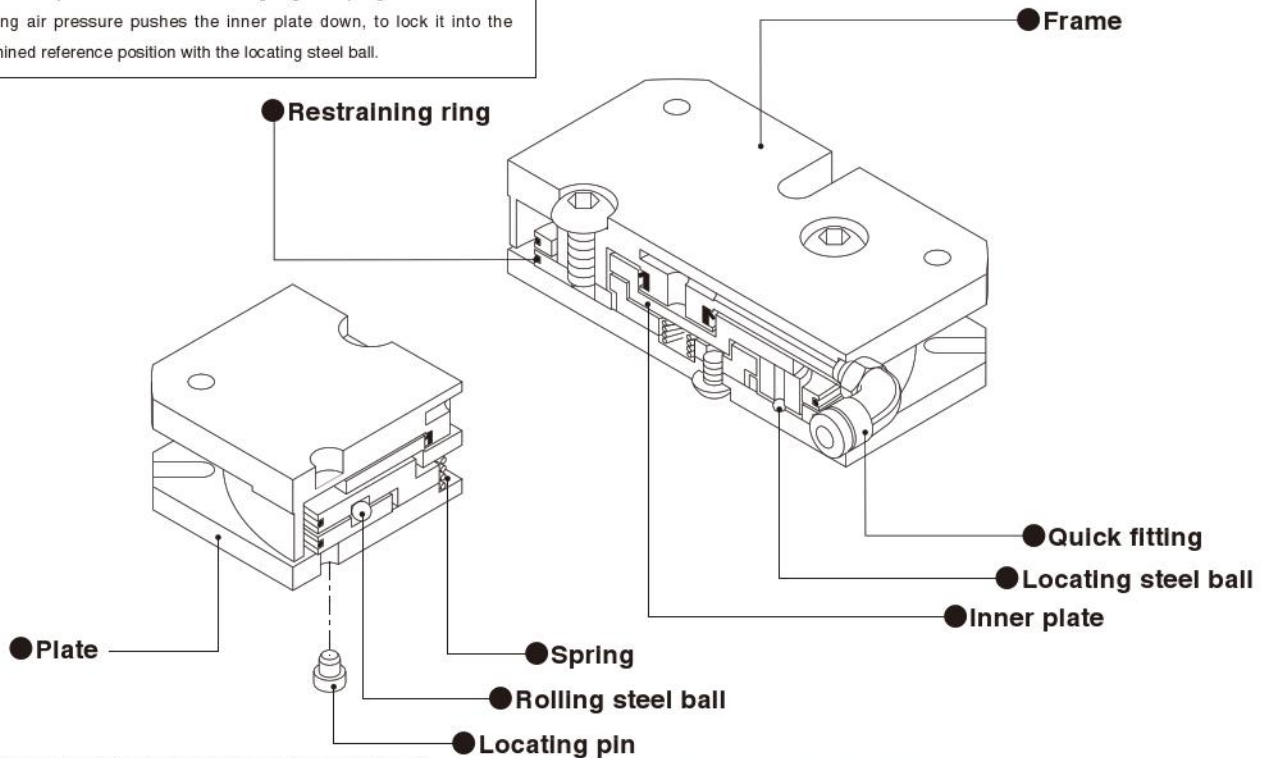

Note: Since loosening the connection screws will go out of the assembly precision, do not disassemble.

(Apply locking adhesive and insert it into the required hole.)

## Specifications

Item		Model		
		SHM 61S	SHM 61M	SHM 61L
Mounting specification	Mounting surface	S	M	L
	Mounted surface	S	M	L
Media		Air		
Operating pressure range MPa [psi.]		0.2~0.6 [29~87]		
Proof pressure MPa [psi.]		1 [145]		
Operating temperature range °C [°F]		0~60 [32~140]		
Operation type and mechanism		Horizontal passive type, with locking mechanism <sup>Note</sup>		
Lubrication		Not required		
Load mass kg [lb.]		1.5 [3.3]	3 [6.6]	4.5 [9.9]
Movement range	X·Y mm [in.]	±1.0 [±0.039]		
	Z mm [in.]	-0.5 [-0.020]		
	$\theta$	±2.5°		
	$\alpha$	±0.6°		
Centripetal force N [lbf.]		5 [1.1]		
Repeatability when locked mm [in.]		±0.02 [±0.0008]		
Mass g [oz.]		200 [7.1]	420 [14.8]	600 [21.2]

Note: Applying air pressure brings it into a locked state.

## Order Codes

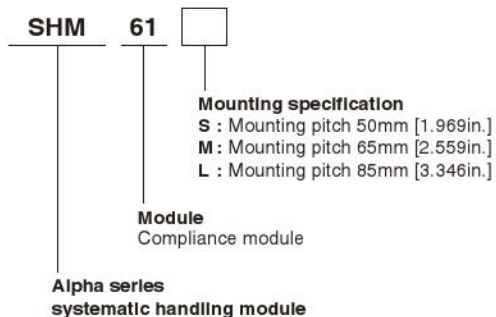

※ Two locating pins are included.

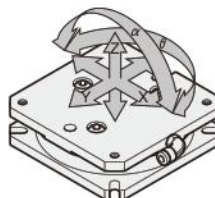

## Explanation of term

Centripetal force: The compliance module uses a restraining ring to keep its center with a force of 5N [1.1lbf.]. This force is called "centripetal force."

# Dimensions of SHM61S, M, L (mm)

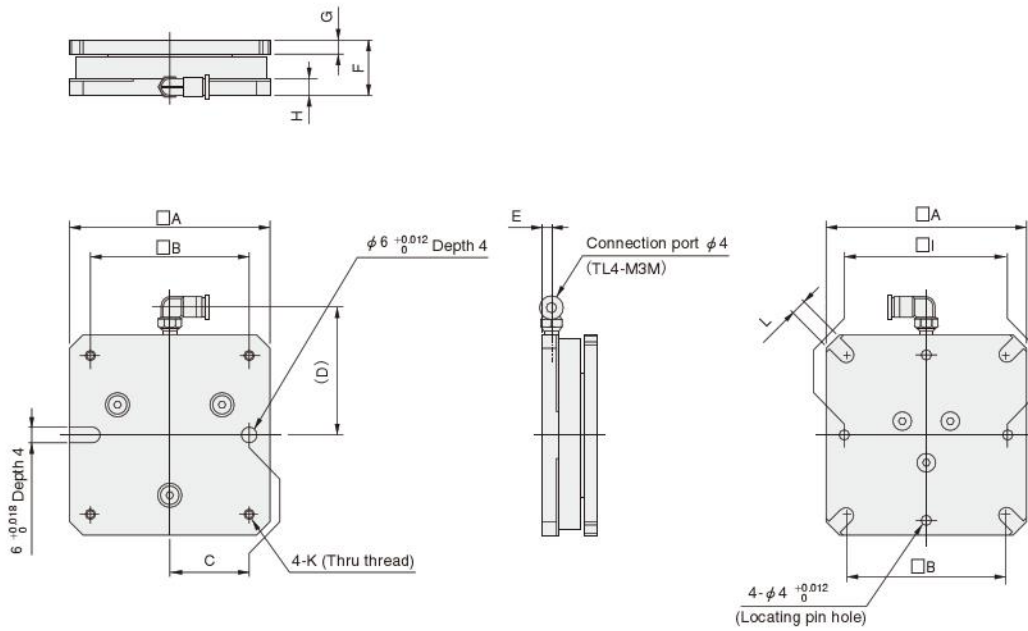
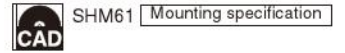

- Remarks: 1. Tolerance of the contact surface parallelism between mounting surface and mounted surface = S : 0.04, M : 0.05, L : 0.06  
 2. Coaxiality tolerance with the hypothetical center, as restricted by the locating pin = S :  $\phi 0.04$ , M :  $\phi 0.05$ , L :  $\phi 0.06$

Code Model	A	B	C	D	E	F	G	H	I	K	L
SHM61S	60	50	25.0	42	3	20	4	5.5	$50 \pm 0.03$	M4	4.5
SHM61M	80	65	32.5	52	3	23	5	6.0	$65 \pm 0.03$	M4	4.5
SHM61L	100	85	42.5	62	3.5	28	7	7.0	$85 \pm 0.06$	M5	5.5

## Application Example

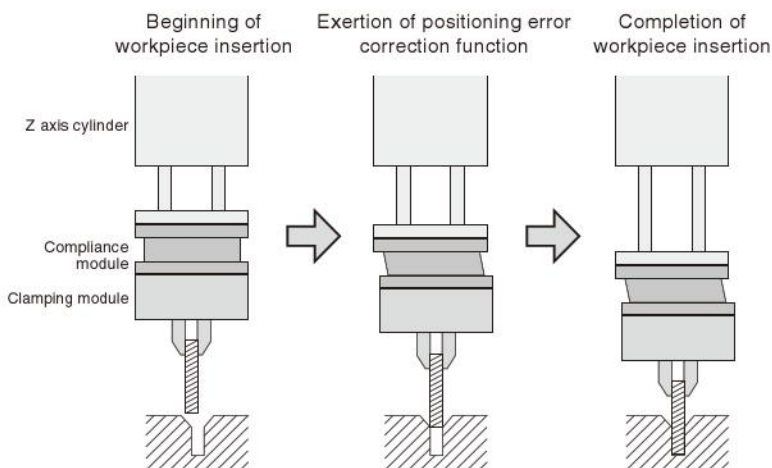

# COMPLIANCE MODULES

## NZ Specification



This compliance module eliminates positioning error correction in the Z and  $\alpha$  directions, and reduces galling during workpieces insertion.

### Operation principles

1. The frame and plate enclose rolling steel balls, which move freely under the light centripetal force of the restraining ring and spring.
2. Applying air pressure pushes the inner plate down, to lock it into the determined reference position with the locating steel ball.

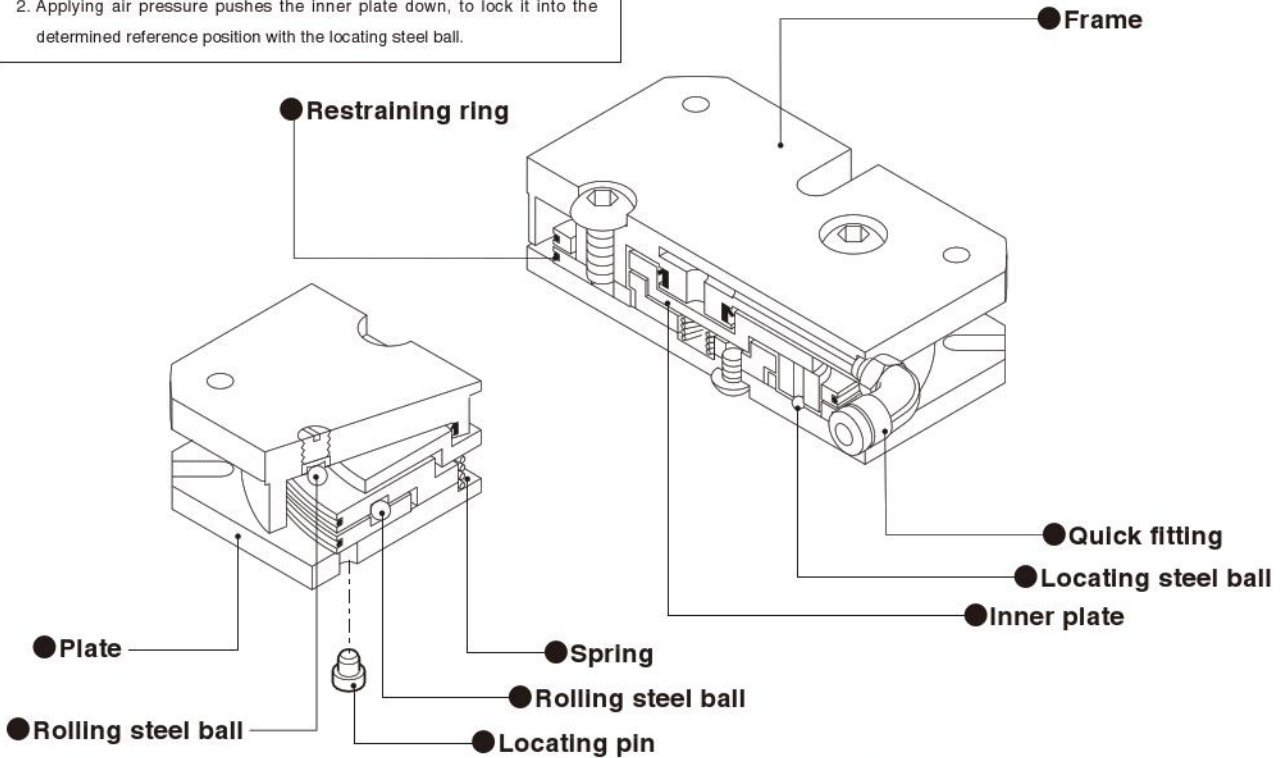

Note: Since loosening the connection screws will go out of the assembly precision, do not disassemble.

(Apply locking adhesive and insert it into the required hole.)

### Specifications

Item		Model		
		SHM 62S	SHM 62M	SHM 62L
Mounting specification	Mounting surface	S	M	L
	Mounted surface	S	M	L
Media		Air		
Operating pressure range		MPa [psi] 0.2~0.6 [29~87]		
Proof pressure		MPa [psi] 1 [145]		
Operating temperature range		°C [°F] 0~60 [32~140]		
Operation type and mechanism		Horizontal passive type, with locking mechanism <sup>Note</sup>		
Lubrication		Not required		
Load mass		kg [lb.] 1.5 [3.3]	3 [6.6]	4.5 [9.9]
Movement range	X·Y	mm [in.] ±1.0 [±0.039]		
	Z	mm [in.] —		
	$\theta$	° ±2.5°		
	$\alpha$	—		
Centripetal force		N [lbf.] 5 [1.1]		
Repeatability when locked		mm [in.] ±0.02 [±0.0008]		
Mass		g [oz.] 200 [7.1]	420 [14.8]	600 [21.2]

Note: Applying air pressure brings it into a locked state.

### Order Codes

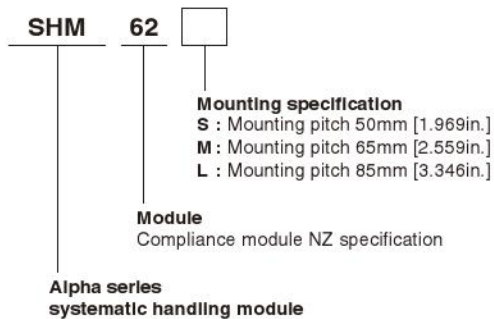

※ Two locating pins are included.

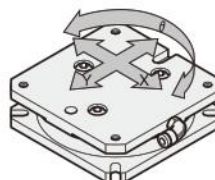

**Moving directions of NZ specification**  
 Moves in the X, Y, and  $\theta$  directions, as shown in the diagram to the left.

# Dimensions of SHM62S, M, L (mm)

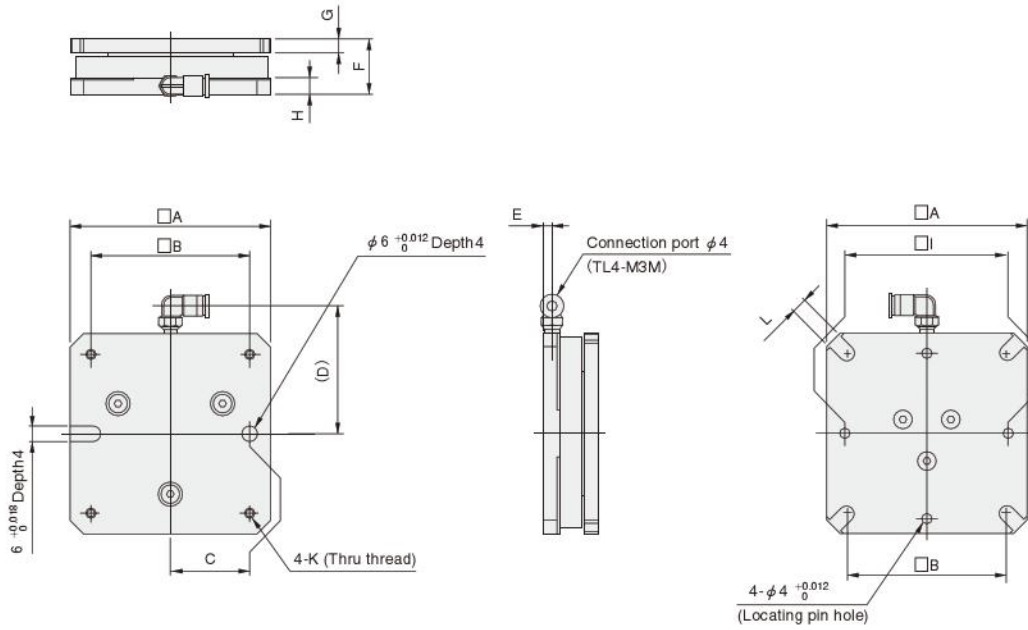

- Remarks: 1. Tolerance of the contact surface parallelism between mounting surface and mounted surface = S : 0.04, M : 0.05, L : 0.06  
 2. Coaxiality tolerance with the hypothetical center, as restricted by the locating pin = S :  $\phi 0.04$ , M :  $\phi 0.05$ , L :  $\phi 0.06$

Code Model	A	B	C	D	E	F	G	H	I	K	L
SHM 62S	60	50	25.0	42	3	20	4	5.5	$50 \pm 0.03$	M4	4.5
SHM 62M	80	65	32.5	52	3	23	5	6.0	$65 \pm 0.03$	M4	4.5
SHM 62L	100	85	42.5	62	3.5	28	7	7.0	$85 \pm 0.05$	M5	5.5

# PARALLEL CLAMPING MODULES

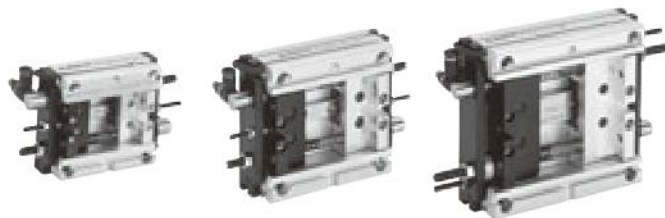

This module plays the role of fingers in the hand (gripper) unit. Because the cylinder operates asynchronously, it has superior positioning during clamping. It is particularly suitable for small workpieces.

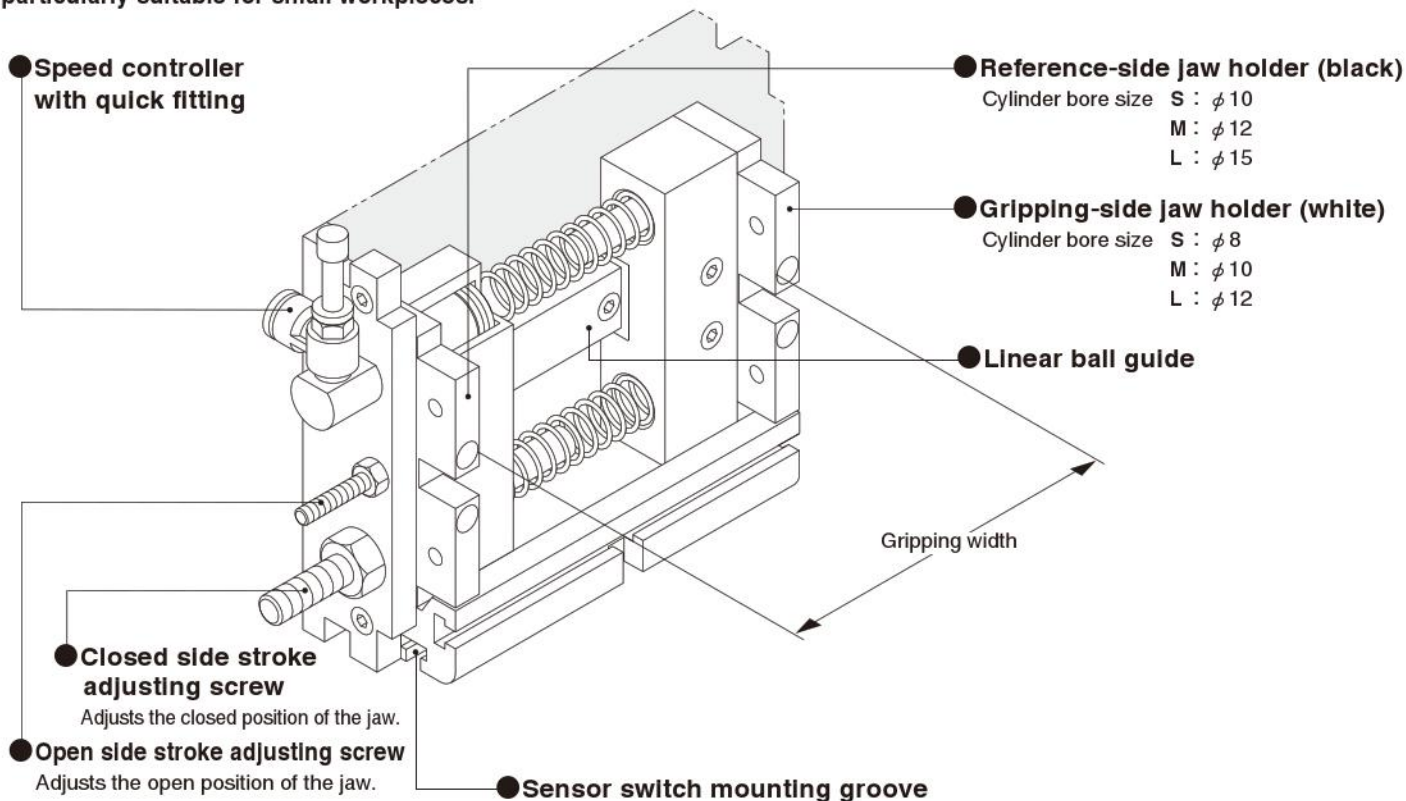

Note: Since loosening the connection screws will go out of the assembly precision, do not disassemble.

## Specifications

Model		SHM71S	SHM71M	SHM71L
Item	Mounting surface	S	M	L
Cylinder bore size	mm [in.]	8 [0.315] (10 [0.394])	10 [0.394] (12 [0.472])	12 [0.472] (15 [0.591])
Stroke	mm [in.]	One side 8 [0.315]	One side 12 [0.472]	One side 15 [0.591]
Media		Air		
Operating pressure range	MPa [psi.]	0.2~0.6 [29~87]		
Proof pressure	MPa [psi.]	1 [145]		
Operating temperature range	°C [°F]	0~60 [32~140]		
Operation type and mechanism		Normally open single acting type, asynchronous type, linear ball guide, with stroke adjusting mechanism		
Lubrication		Not required		
Gripping force <sup>Note</sup>	When open (Spring force)	2.5~6.9 [0.56~1.55]	3.9~12.7 [0.88~2.85]	5.1~12.9 [1.15~2.90]
	When closed	21.6—Spring force [4.9—Spring force]	33.3—Spring force [7.5—Spring force]	48.1—Spring force [10.8—Spring force]
Allowable moment	Pitching	100 [8.9]	210 [18.6]	460 [40.7]
	Yawing	120 [10.6]	240 [21.2]	540 [47.8]
	Rolling	160 [14.2]	290 [25.7]	980 [86.7]
Repeatability	mm [in.]	±0.01 [±0.0004]		
Maximum operating frequency	cycle/min	40		
Sensor switches		Operation detection X2		
Gripping width	mm [in.]	26~42 [1.02~1.65]	33~57 [1.30~2.24]	43~73 [1.69~2.87]
Mass	g [oz.]	240 [8.5]	450 [15.9]	880 [31.0]

Note: Values at 0.5MPa [73psi.] air pressure.

## Order Codes

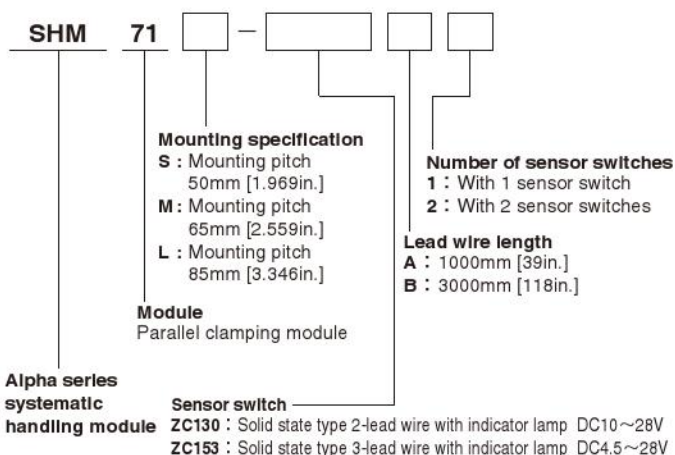

### Order codes for sensor switches only

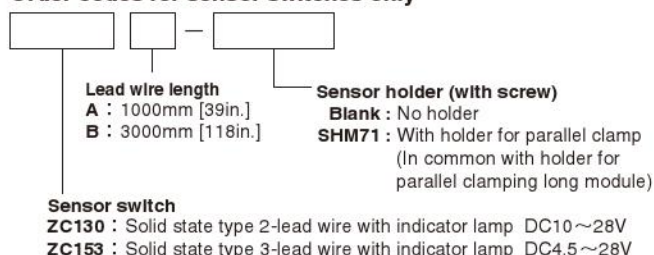

● For details of sensor switches, see p.1544.

# Dimensions of SHM71S, M, L (mm)

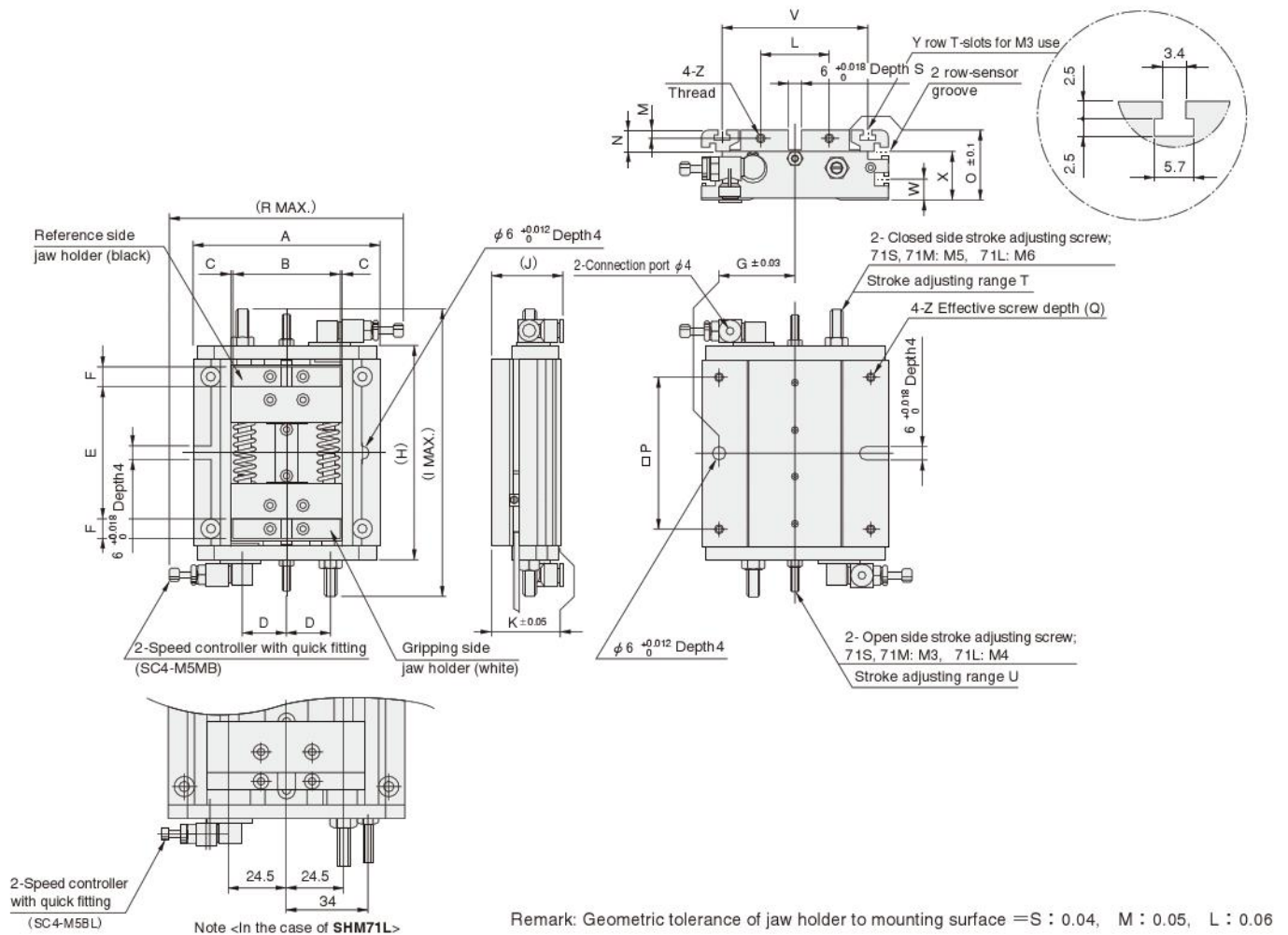
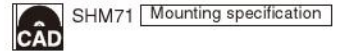

Code	A				E		F	G	H	I	J	K	L	M	N	O	P	Q	R	S	T	U	V	W	X	Y	Z
	B	C	D	Maximum when open	Minimum when closed																						
SHM71S	60	32	0.5	14.5	42	26	6	25.0	72	100	30	25	20	4	8	25	50	4	92	7	8	8	45	—	16	2	M4
SHM71M	80	46	1.0	18.5	57	33	8	32.5	92	122	32	30	30	4	9	30	65	7	100	8	10	10	60	8	21	4	M4
SHM71L	100	64	1.0	Note	73	43	8	42.5	112	155	34	35	40	5	10	35	85	8	110	8.5	15	15	78	10	23	4	M5

## Allowable Moment

Do not apply any moment exceeding the allowable values listed on p.1523.

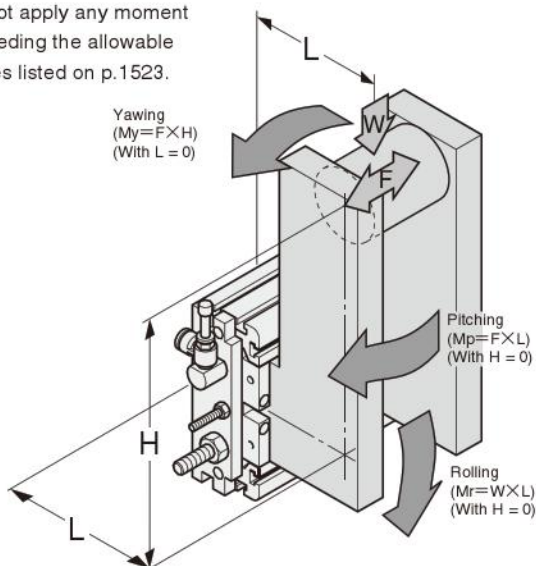

## Comparative Examples

As compared with more commonly used synchronous types, this module employs an asynchronous method (to obtain independent movement in each jaw). In addition, extended and retracted side stroke adjustment allows fine adjustment for workpieces. Since the cylinder bore size of the jaw on one side has been larger and works as a reference side for gripping, and along with the opposite side for slave jaw, it is optimum for gripping workpieces having its reference plane on the side.

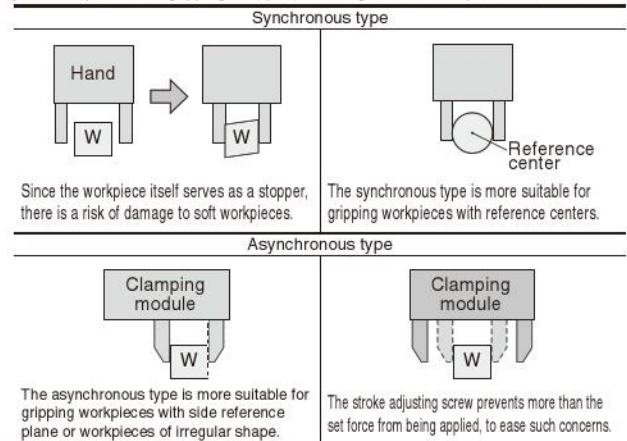

# PARALLEL CLAMPING LONG MODULES



This module plays the role of fingers in the hand (gripper) unit. Because the cylinder is asynchronous, it has superior positioning during clamping. And changing the applied air pressure can make either side serve as the reference jaw. It is particularly suitable for large-sized workpieces.

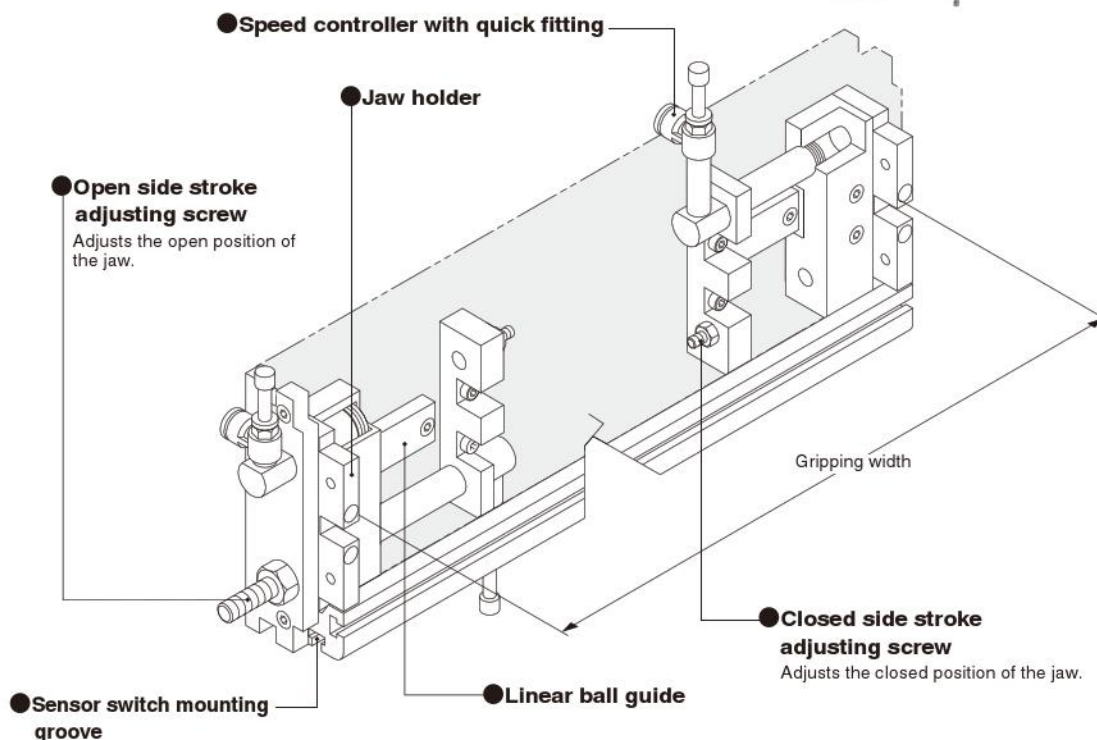

Note : Since loosening the connection screws will go out of the assembly precision, do not disassemble.

## Specifications

Model		SHM 72S			SHM 72M			SHM 72L		
		SL	ML	LL	SL	ML	LL	SL	ML	LL
Mounting specification	Mounting surface	S			M			L		
Bore size	mm [in.]	8 [0.315]			12 [0.472]			15 [0.591]		
Stroke	mm [in.]	One side 20 [0.787]			One side 26 [1.024]			One side 30 [1.181]		
Media		Air								
Operating pressure range	MPa [psi]	0.2~0.6 [29~87]								
Proof pressure	MPa [psi]	1 [145]								
Operating temperature range	°C [°F]	0~60 [32~140]								
Operation type and mechanism		Double acting type, asynchronous type, linear ball guide, with stroke adjusting mechanism								
Lubrication		Not required								
Gripping force <sup>Note</sup>	When open	21.6 [4.9]	48.1 [10.8]	76.4 [17.2]						
	When closed	21.6 [4.9]	48.1 [10.8]	76.4 [17.2]						
Allowable moment	Pitching	100 [8.9]	210 [18.6]	460 [40.7]						
	Yawing	120 [10.6]	240 [21.2]	540 [47.8]						
	Rolling	160 [14.2]	290 [25.7]	980 [86.7]						
Repeatability	mm [in.]	±0.01 [±0.0004]								
Maximum operating frequency	cycle/min	40								
Sensor switches		Operation detection × 4								
Gripping width	mm	100~140	200~240	300~340	124~176	224~276	324~376	258~318	358~418	458~518
Mass	g [oz.]	490 [17.3]	610 [21.5]	730 [25.7]	850 [30.0]	960 [33.9]	1100 [38.8]	1700 [60.0]	1980 [69.8]	2200 [77.6]

Note: Values at 0.5MPa [73psi.] air pressure.

## Order Codes

SHM 72

Gripping width	mm		
Mounting spec.	S	M	L
SL	140	176	318
ML	240	276	418
LL	340	376	518

Module: Parallel clamping long module

Alpha series systematic handling module

Mounting specification:  
 S : Mounting pitch 50mm [1.969in.]  
 M : Mounting pitch 65mm [2.559in.]  
 L : Mounting pitch 85mm [3.346in.]

Sensor switch:  
 ZC130 : Solid state type 2-lead wire with indicator lamp DC10~28V  
 ZC153 : Solid state type 3-lead wire with indicator lamp DC4.5~28V

Lead wire length:  
 A : 1000mm [39in.]  
 B : 3000mm [118in.]

Number of sensor switches:  
 1 : With 1 sensor switch  
 2 : With 2 sensor switches  
 3 : With 3 sensor switches  
 4 : With 4 sensor switches

### Order codes for sensor switches only

Lead wire length:  
 A : 1000mm [39in.]  
 B : 3000mm [118in.]

Sensor holder (with screw):  
 Blank : No holder  
 SHM71 : With holder for parallel clamp (In common with holder for parallel clamping module)

Sensor switch:  
 ZC130 : Solid state type 2-lead wire with indicator lamp DC10~28V  
 ZC153 : Solid state type 3-lead wire with indicator lamp DC4.5~28V

● For details of sensor switches, see p.1544.

# Dimensions of SHM72S, M, L (mm)

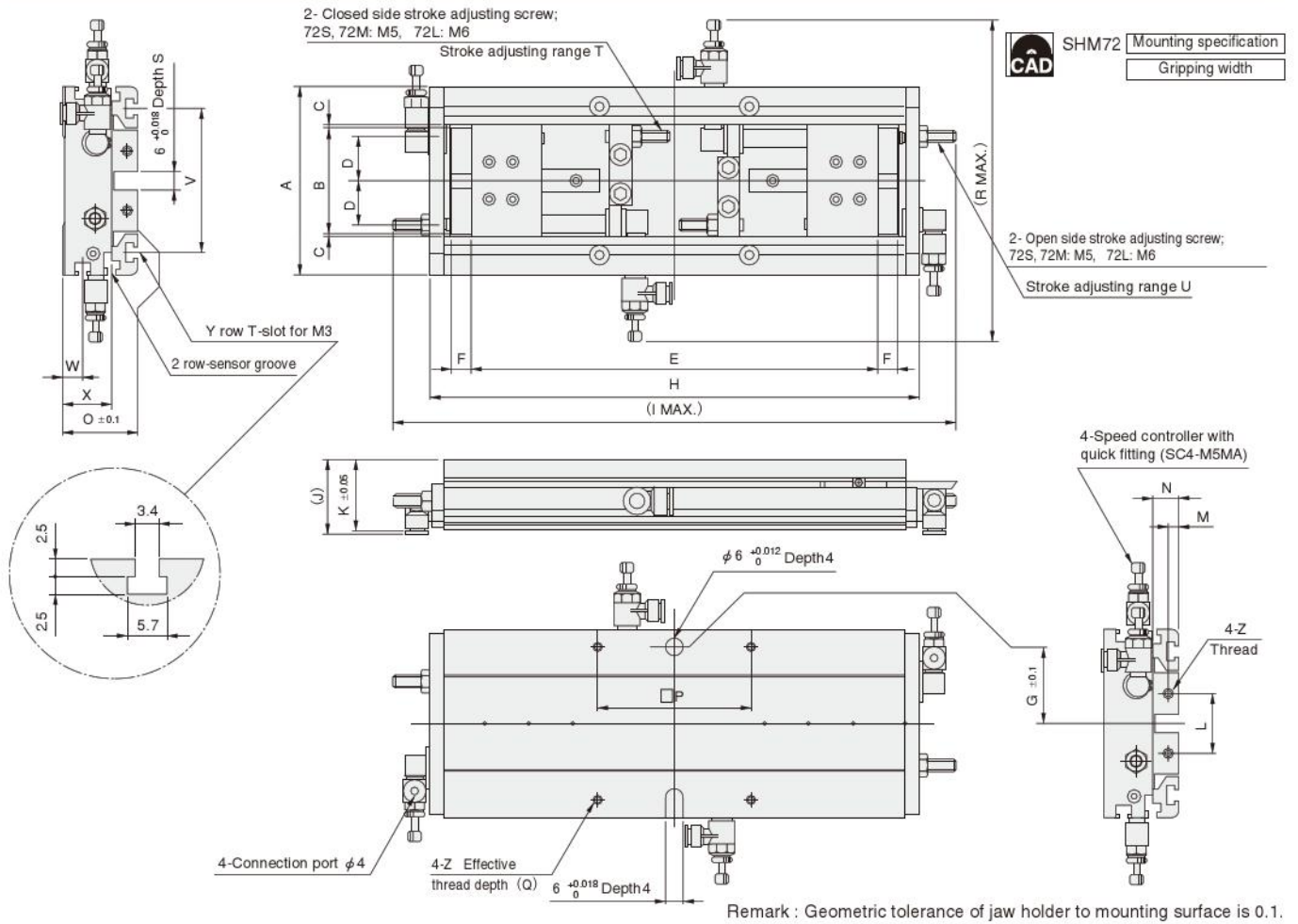

Code	A	B	C	D	E		F	G	H	I	J	K	L	M	N	O	P	Q	R	S	T	U	V	W	X	Y	Z
					Maximum when open	Minimum when closed																					
SHM72S-SL	60	32	0.5	14.5	140	100	6	25.0	172	197	30	25	20	4	8	25	50	4	122	7	7	9	45	—	16	2	M4
SHM72S-ML					240	200															12						
SHM72S-LL					340	300															372						
SHM72M-SL	80	46	1.0	18.0	176	124	8	32.5	212	247	32	30	30	4	9	30	65	7	135	8	10	14	60	8	21	4	M5
SHM72M-ML					276	224															15						
SHM72M-LL					376	324															412						
SHM72L-SL	100	64	1.0	24.5	318	258	8	42.5	352	400	34	35	40	5	10	35	85	8	155	8.5	15	15	78	10	23	4	M5
SHM72L-ML					418	358															15						
SHM72L-LL					518	458															552						

## Allowable Moment

Do not apply any moment exceeding the allowable values listed on p.1525.

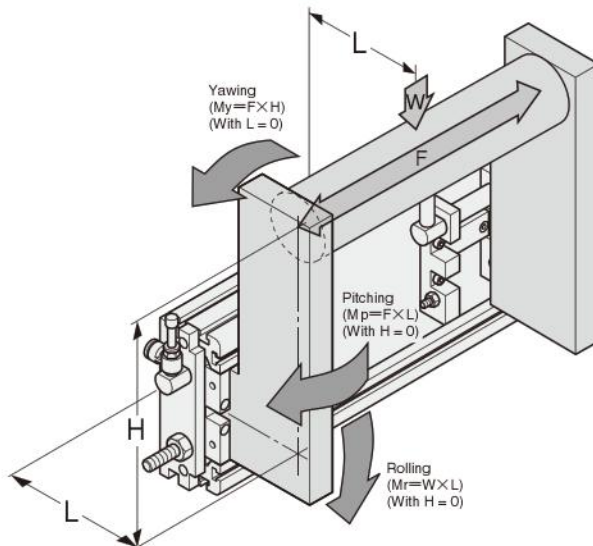

# SHOCK ABSORBERS

## Specifications

### ● KSHA Series for Turning Module

Basic model	KSHA6×5-D	KSHA6×5-DE	KSHA6×8-F
Item			
Maximum absorption J [ft·lbf]	1.0 [0.74]	1.5 [1.11]	2.9 [2.14]
Maximum impact speed m/s [ft./sec.]	1.0 [3.28]		
Maximum operating frequency cycle/min	60		30
Absorbing stroke mm [in.]	5 [0.197]	8 [0.315]	
Operating temperature range °C [°F]	0~60 [32~140]		
Mass g [oz.]	10 [0.35]	20 [0.71]	

### ● KSHAH Series for Reversing Module

Basic model	KSHAH6×3	KSHAH6×4	KSHAH6×5
Item			
Maximum absorption J [ft·lbf]	0.3 [0.22]	0.9 [0.66]	1.4 [1.03]
Maximum impact speed m/s [ft./sec.]	0.1 [0.33]		
Maximum operating frequency cycle/min	60		
Absorbing stroke mm [in.]	3 [0.118]	4 [0.157]	5 [0.197]
Operating temperature range °C [°F]	0~60 [32~140]		
Mass g [oz.]	14 [0.49]	18 [0.63]	22 [0.78]

## Dimensions (mm)

### ● KSHA

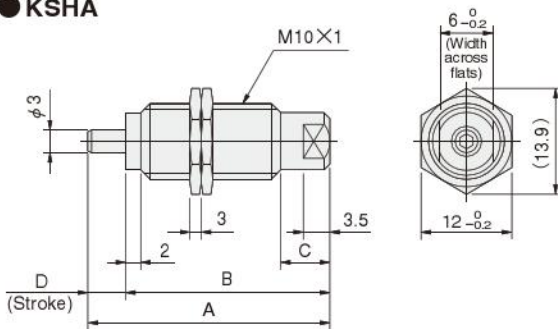

Model	A	B	C	D
KSHA6×5-D	30.5	25.5	7	5
KSHA6×5-DE				
KSHA6×8-F	48	40	10	8

### ● KSHAH

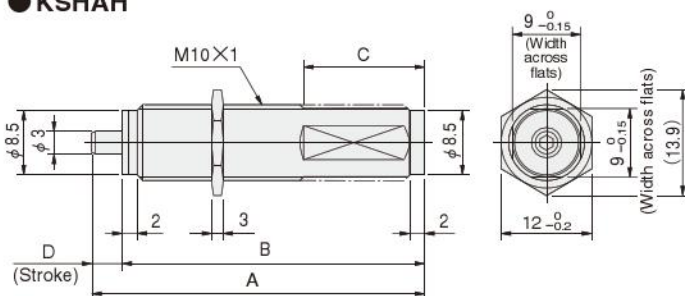

Model	A	B	C	D
KSHAH6×3	33	30	16	3
KSHAH6×4	44	40		4
KSHAH6×5	53	48	22	5

**Either single use or various combinations are possible.**

● **Application Example as Robotic Fingers**

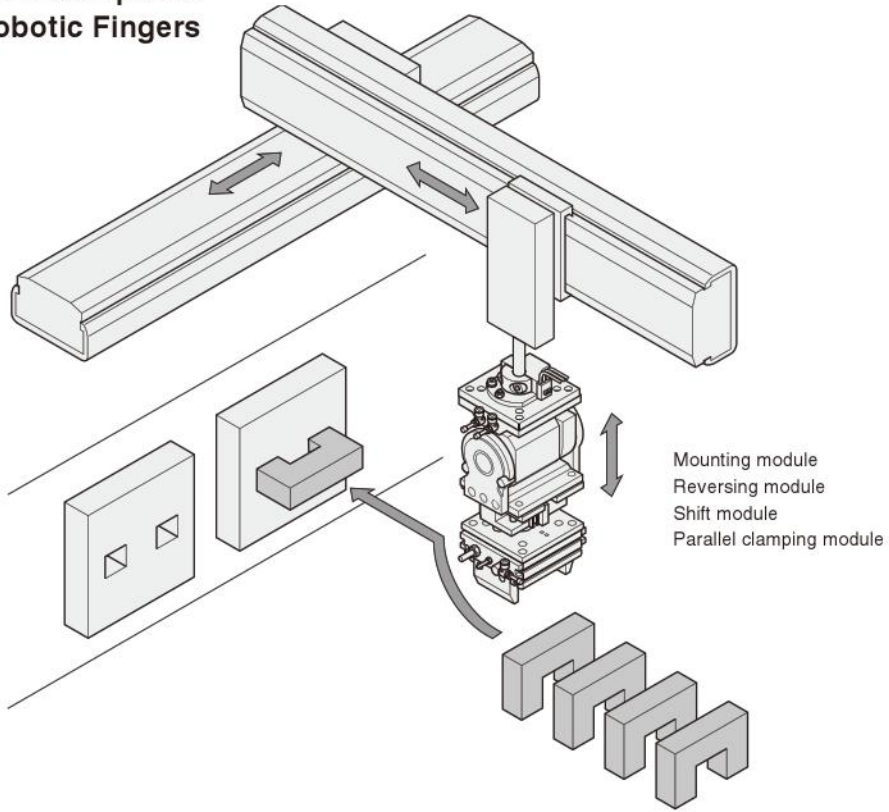

● **Application Example for Conveyor Line**

