

More precision



alpha series

We have added advanced positioning precision and high rigidity to the pneumatic actuator.

The Koganel Alpha Series further enhances the drive module concept, supporting superior applications and labor savings in FA line design and manufacturing with higher performance.

Systematic Handling Module Micro series

Positioning



- Compatible to downsizing
Both the mounting surface and the mounted surface are $\square 40\text{mm}$ [1.575in.] compact size (mounting pitch 32mm [1.260in.]).

- Quick fitting (standard equipment)
Quick fitting for $\phi 4$ [0.157in.] tube is installed.

Compliance module

Chucking

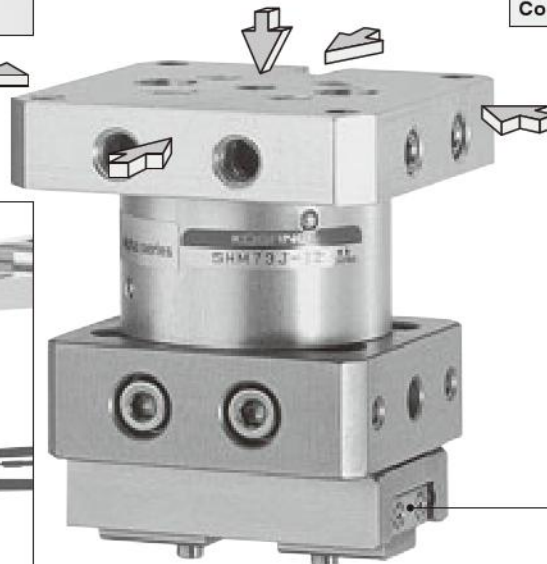
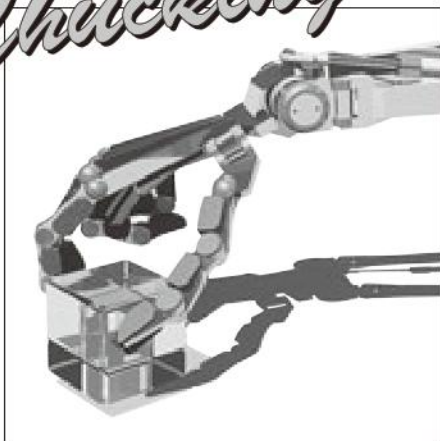

- Space-saving design
Piping connection ports on 5 surfaces flexibly respond to device design.

- High accuracy and high rigidity
Uses highly reliable linear guides.

Parallel clamping modules

Now the Micro Series with advanced compact-size design has arrived!
Devices for positioning error correction and gripping in the handling process are smaller and weigh less (compared with previous Koganei products) when equipped with the Micro Series.
High-precision achieves smooth chucking and handling, demonstrating its effectiveness in reducing robot gripper costs.

■ Series Composition

POSITIONING ERROR CORRECTION FUNCTION

Compliance Modules

- A restraining ring provides a light centripetal force to correct for errors in positioning.
- Demonstrates superior centripetal force that maintains the centered positioning.
- Compact module with a mounting surface of □40mm [1.575in.] and a mounting pitch of 32mm [1.260in.].
- Applying air pressure can lock the locating steel ball for positioning into the determined reference position.

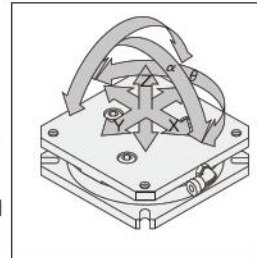

Moving directions of SHM61J

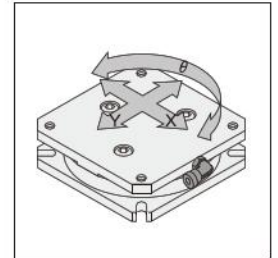

Moving directions of SHM62J (NZ specification)

SHM61J SHM62J (NZ specification)

J size
(Mounting pitch : 32mm [1.260in.])



SHM61J



SHM62J
(NZ specification)

GRIPPING FUNCTION

Parallel Clamping Modules

- Two types with mounting surfaces of □40mm [1.575in.] and mounting pitches of 32mm [1.260in.], and one type with a mounting surface of □30mm [1.181in.] and mounting pitch of 24mm [0.945in.].
- Linear guides achieve a longer grip length and overhang grip.
- Connection ports on 5 surfaces provide rational device design.
- Repeating gripping accuracy is ±0.01mm [0.0004in.].
- Open/closed stroke of 6mm [0.236in.] and 8mm [0.315in.]. Suitable for small workpieces.

SHM73J-16

J size (Mounting pitch: 32mm [1.260in.])

◆Nominal bore size: φ 16 [0.630in.]



SHM73J-16

SHM73J-12

J size (Mounting pitch: 32mm [1.260in.])

◆Nominal bore size: φ 12 [0.472in.]



SHM73J-12

SHM73B-12

Suitable for picking and placing a small workpiece or in tight locations.

B size (Mounting pitch: 24mm [0.945in.])

◆Nominal bore size: φ 12 [0.472in.]



SHM73B-12

Caution: SHM73B-12 cannot be installed directly to the compliance module.

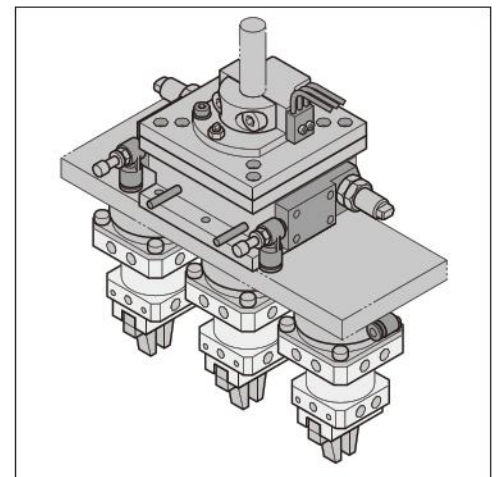

Application example of a compliance module and parallel clamping modules

PARALLEL CLAMPING MODULES



This module plays the role of fingers in the hand (gripper) unit. It is a synchronous open/closed stroke type using linear guides.

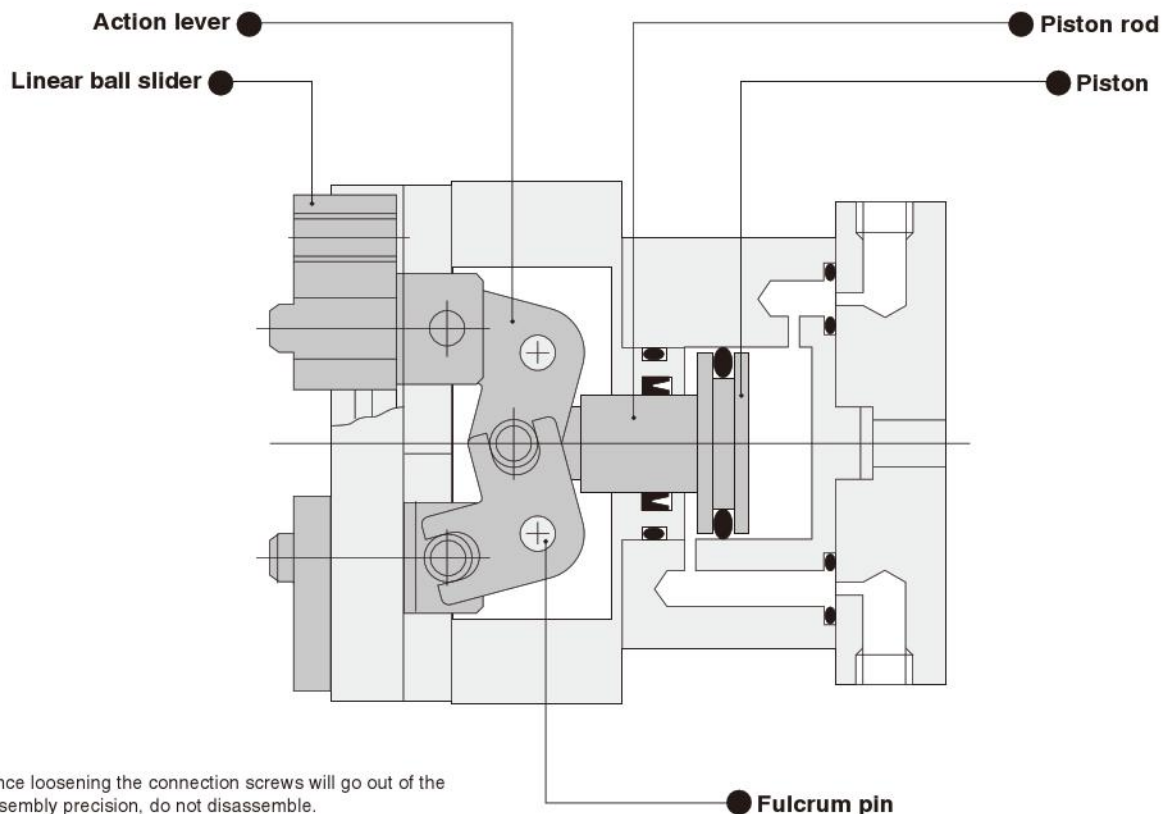

Note: Since loosening the connection screws will go out of the assembly precision, do not disassemble.

Specifications

Item		Model	SHM73J-16	SHM73J-12	SHM73B-12
		Mounting surface	J		B
Bore size	mm [in.]	16 [0.630]	12 [0.472]		
Operation type		Double acting type			
Operating pressure range	MPa [psi.]	0.2~0.6 [29~87]			
Proof pressure	MPa [psi.]	1.0 [145]			
Maximum operating frequency	cycle/min	180			
Lubrication		Not required			
Effective gripping force ^{Note}	Closed side N [lbf.]	33.0 [7.42]	17.0 [3.82]		
	Open side N [lbf.]	43.0 [9.67]	22.5 [5.06]		
Open/closed stroke	mm [in.]	8±0.5 [0.315±0.020]	6±0.5 [0.236±0.020]		
Repeatability	mm [in.]	±0.01 [±0.0004]			
Port size		M5×0.8			
Mass	g [oz.]	240 [8.47]	135 [4.76]	120 [4.23]	

Note : Values are for a grip point length of 30mm [1.18in.], and pressure of 0.5MPa [73psi.]. For details, see graphs of the effective gripping force on p.1502.

Order Codes

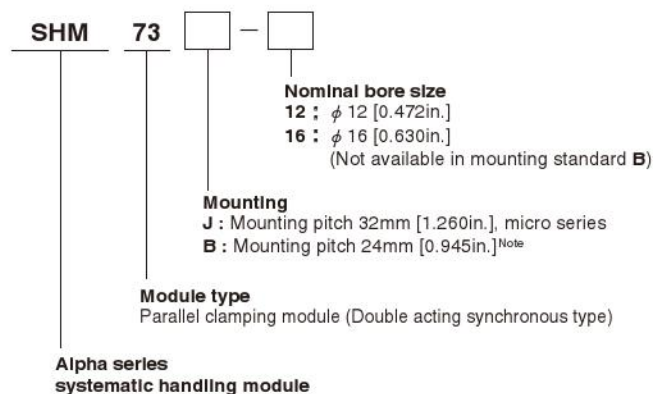

Caution: The nominal bore size for mounting **B** (mounting pitch 24mm [0.945in.]) is for ϕ 12 [0.472in.] only. Moreover, **B** sized product cannot be installed directly onto a compliance module of J size.

Dimensions of SHM73J-16 (mm)

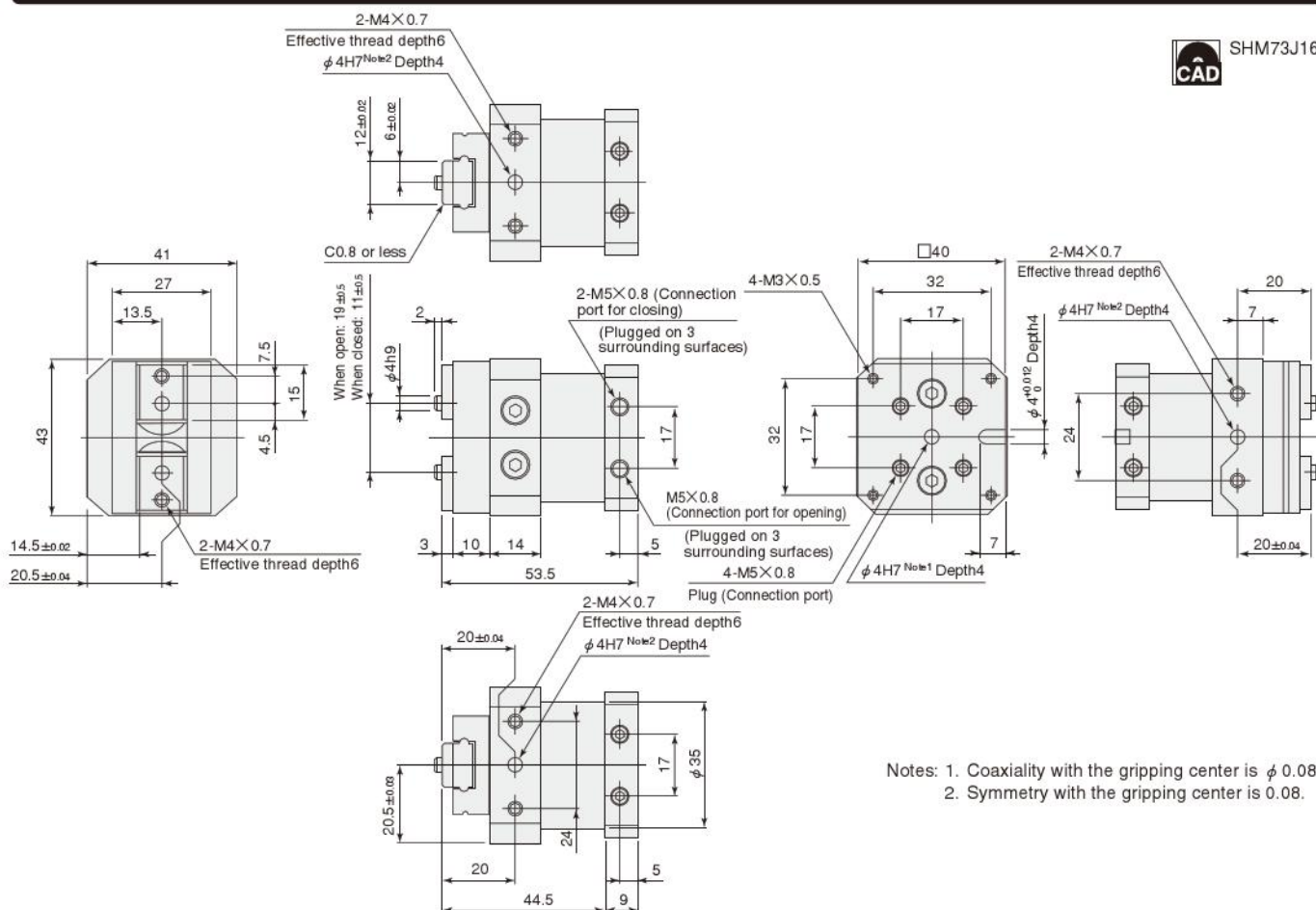

Notes: 1. Coaxiality with the gripping center is φ 0.08.
2. Symmetry with the gripping center is 0.08.

Dimensions of SHM73J-12 (mm)

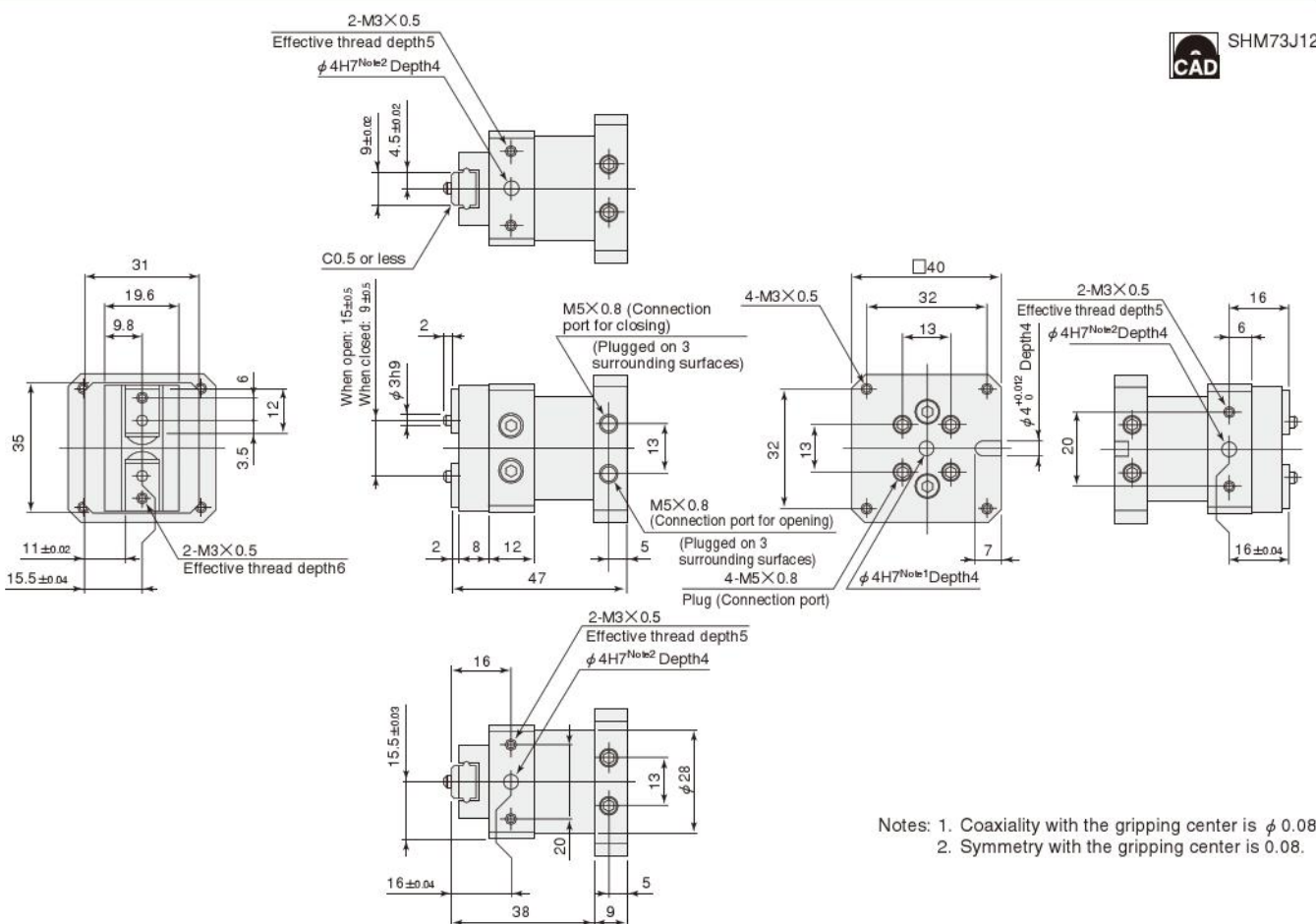

Notes: 1. Coaxiality with the gripping center is φ 0.08.
2. Symmetry with the gripping center is 0.08.

Dimensions of SHM73B-12 (mm)

Note: Cannot be mounted directly onto the compliance module.

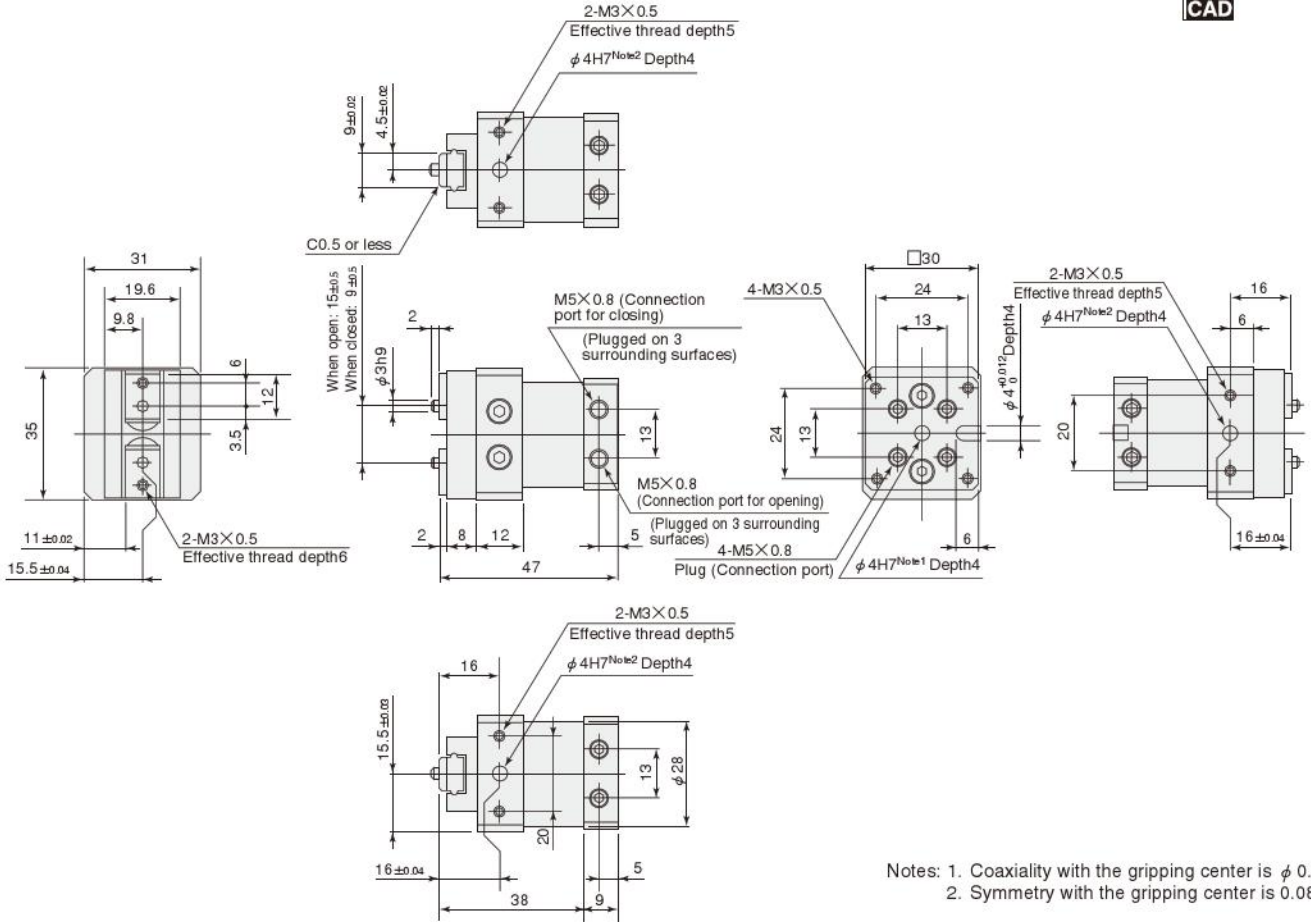

Explanation of Connection Port Location of Parallel Clamping Module

Only the ports on the body front (labeled surface) can be used at shipping. Connection ports on the other surfaces are plugged.

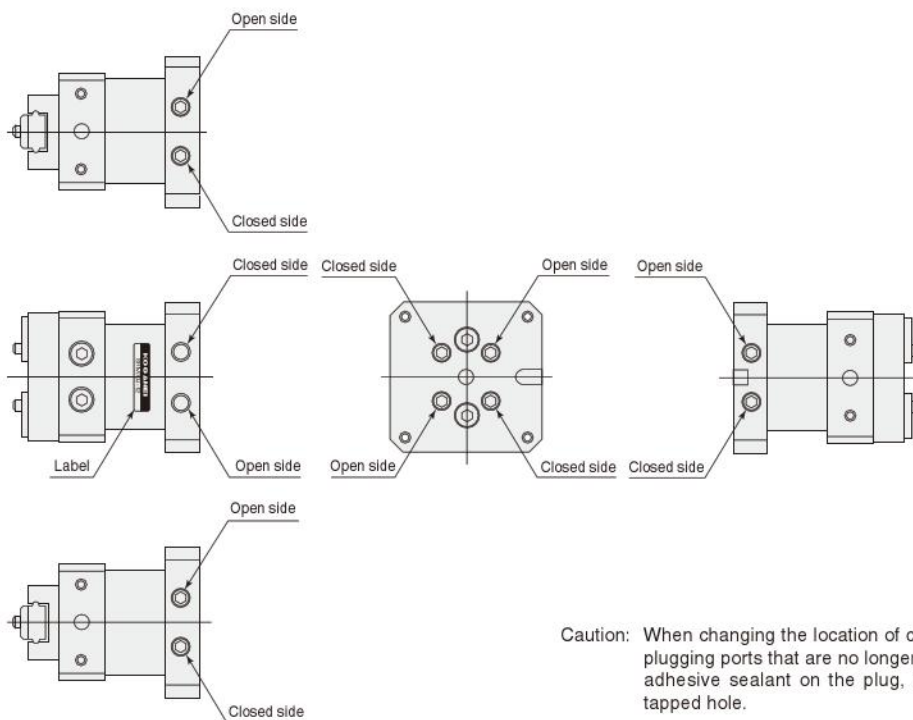

Caution: When changing the location of connection ports and plugging ports that are no longer used, always apply adhesive sealant on the plug, and thread into the tapped hole.

Effective Gripping Force and Grip Point Limiting Range

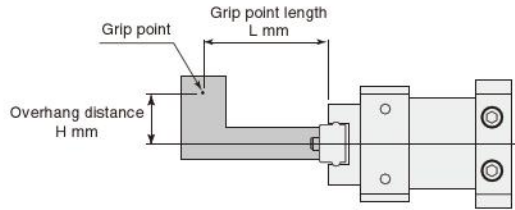

● SHM73J-16

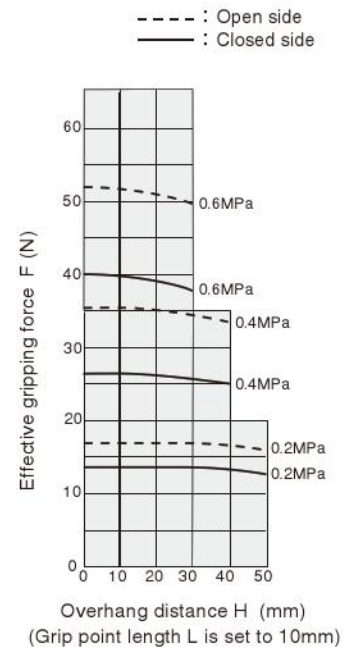
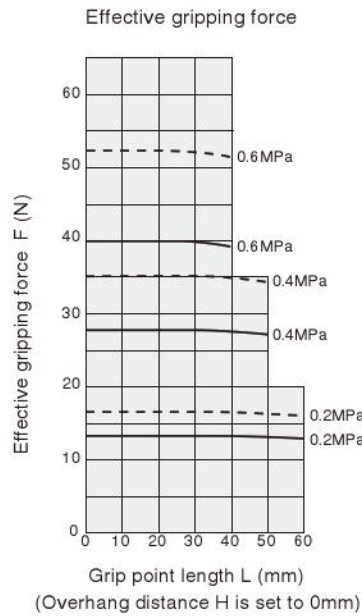
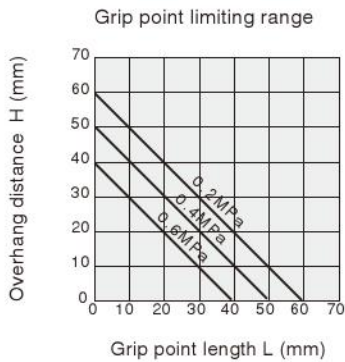

1N = 0.2248lbf. 1MPa = 145psi. 1mm = 0.0394in.

● SHM73J-12, SHM73B-12

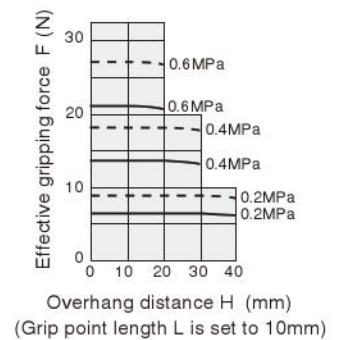
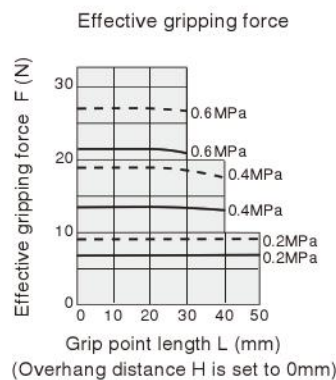
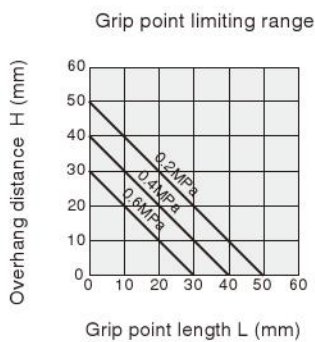

1N = 0.2248lbf. 1MPa = 145psi. 1mm = 0.0394in.

Handling Instructions and Precautions



Compliance module

1. When operating the module body in either a linear or turning movement, apply air pressure to it and bring it in a locked state. Moreover, install a shock absorber, etc., where the movement comes to a standstill to ensure as smooth a stop as possible. Sudden stops may cause the lock to disengage, and reduce the centripetal accuracy.
2. Use it within the range of the allowable load capacity. Too much load could cause wear and degradation in the sliding portion.
3. Always use it in a horizontal position.
4. Care should be taken that movement (compliance) can be obstructed by piping and wiring when grippers or another module is mounted on the mounted surface.



Parallel clamping modules

1. When attaching fingers on the levers, design them to be as short and lightweight as possible. Long, heavy fingers cause greater shocks during opening/closing, and may result in lower gripping accuracy and in wear or damage to the sliding portion.
2. Attach plastic or rubber materials to the contact points of the finger and workpiece, to avoid workpiece from falling, to prevent damage, and to reduce metallic contact noise during clamping.
3. Excessive moments on the lever exerted by gripping may be caused by a long grip point or high air pressure, and may cause damage to the lever. See the grip point limiting range graphs (on p.1502) and always use them within the range.
4. Excessive opening/closing lever speed increases the shocks during opening/closing, which can reduce gripping accuracy and cause wear or damage. Consider using something such as speed controllers to reduce the shock as much as possible when gripping workpieces.
5. When operating the module body in either a linear or turning movement, install a shock absorber, etc., where the movement comes to a standstill to ensure as smooth a stop as possible. Sudden stops may cause the workpiece to jump out or fall.
6. When attaching fingers on the lever, use something such as a wrench to hold the lever so that it does not become twisted. For the tightening torques of the mounting bolts, see the table below.

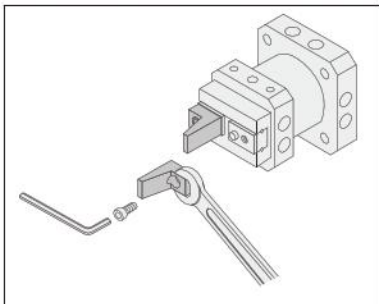

Model	Bolts	Maximum tightening torque N·m [ft·lbf]
SHM73J-12, SHM73B-12	M3×0.5	0.59 [0.44]
SHM73J-16	M4×0.7	1.37 [1.01]

7. If at all possible, avoid applications that apply lateral loads, or compression or tensile loads to the lever. Consult us if such an application is required.
8. Set the mass of the workpiece actually being gripped at about 1/10~1/20 of the effective gripping force.
9. When the workpiece is being moved while gripped, set the workpiece mass to about 1/30~1/50 of the effective gripping force.
10. Since the material and shape of the fingers, the conditions of the gripping surface, and the moving speed, etc., can have a great effect on how much workpiece mass can be gripped, use the specification tables and the values in the graphs as a guide only.



General precautions

Piping

Always thoroughly blow off (use compressed air) the tubing before piping. Entering metal chips, sealing tape, rust, etc., generated during piping work could result in air leaks or other defective operation.

Atmosphere

1. Avoid using in locations subject to dripping water, dripping oil, or to large amounts of dust.
2. The product cannot be used when the media or ambient atmosphere contains any of the substances listed below.
Organic solvents, phosphate ester type hydraulic oil, sulphur dioxide, chlorine gas, or acids, etc.

Lubrication

The product can be used without lubrication, if lubrication is required, use Turbine Oil Class 1 (ISO VG32) or equivalent.

Media

1. Use air for the media. For the use of any other media, consult us.
2. Use clean air which does not contain deteriorated compressor oil, etc.
3. Install an air filter (filtration of a minimum 40 μm) near the modules to remove collected liquid or dust. In addition, drain the air filter periodically.