

# More precision



We have added advanced positioning precision and high rigidity to the pneumatic actuator.

The Koganei Alpha Series further enhances the drive module concept, supporting superior applications and labor savings in FA line design and manufacturing with higher performance.

## Systematic Handling Module

*The handling module has mounting, turning, linear motion, positioning error correction, and gripping functions, which serve to shorten the design time regarding the material handling process, to reduce costs, and to deliver performance for the early set-up of automated lines.*

### Standardized modules

The handling operation is classified, standardized, and modularized into 7 functions.

As a result, designers can immediately complete the handling unit by combining modules organized by functions.

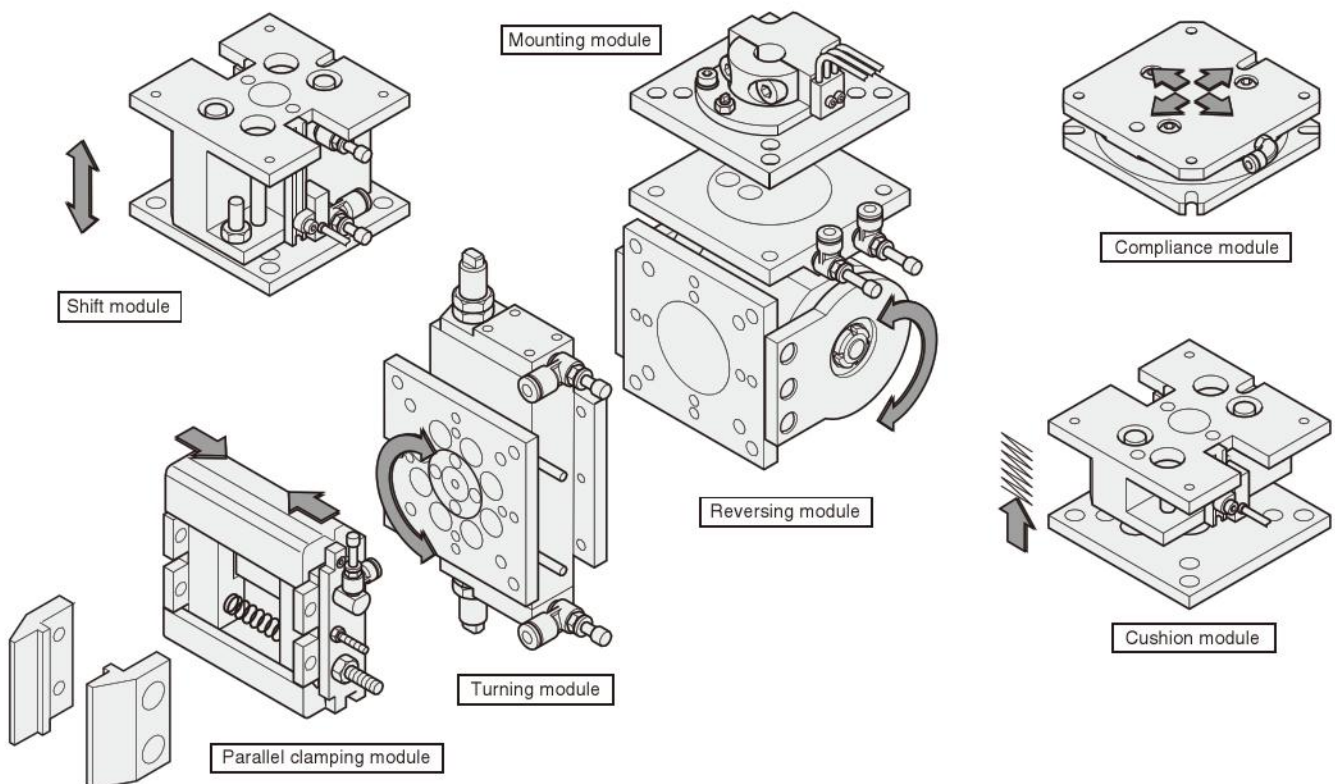

## Assure high accuracy

High machining and assembly precision of the module ensure high accuracy in single-unit use or combination use.

Repeatability in each module	
Turning module	$\pm 0.03^\circ$
Reversing module	$\pm 0.03^\circ$
Shift module	$\pm 0.05\text{mm}$ [ $\pm 0.0020\text{in.}$ ]
Cushion module	$\pm 0.05\text{mm}$ [ $\pm 0.0020\text{in.}$ ]
Compliance module	$\pm 0.02\text{mm}$ [ $\pm 0.0008\text{in.}$ ]
Parallel clamping module	$\pm 0.01\text{mm}$ [ $\pm 0.0004\text{in.}$ ]

- Tolerance of the contact surface parallelism between mounting surface and mounted surface  
=S : 0.04, M : 0.05, L : 0.06

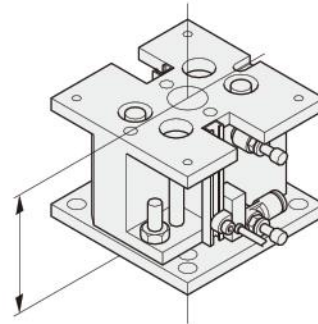

- Tolerance of the coaxiality with the hypothetical center, as restricted by the locating pin =S :  $\phi 0.04$ , M :  $\phi 0.05$ , L :  $\phi 0.06$

## Commonality of mounting pitch

### ● Full choice mounting method

The Systematic Handling Module is a standard module that provides handling operations in the precision assembly field by 7 classified functions, for a complete series. Moreover, the module uses the full choice mounting method that makes any combinations possible while keeping the excellent positioning accuracy.

### Features

- ① Common mounting dimensions for each size
- ② Bottom surfaces can be used to mount the same size or one smaller sized module.
- ③ To ensure accurate positioning of the handling modules, there are dowel pin holes on contacted surface of each modules, and locating pins are available (2 locating pins supplied with each module, with the exception of the parallel clamping module).

	mm [in.]						
	A	B	C	D	E	F	G
S size	60 [2.362]	50 [1.969]	—	—	M4	—	M4
M size	80 [3.150]	65 [2.559]	50 [1.969]	M4	M4	4 [0.157]	M5
L size	100 [3.937]	85 [3.346]	65 [2.559]	M4	M5		

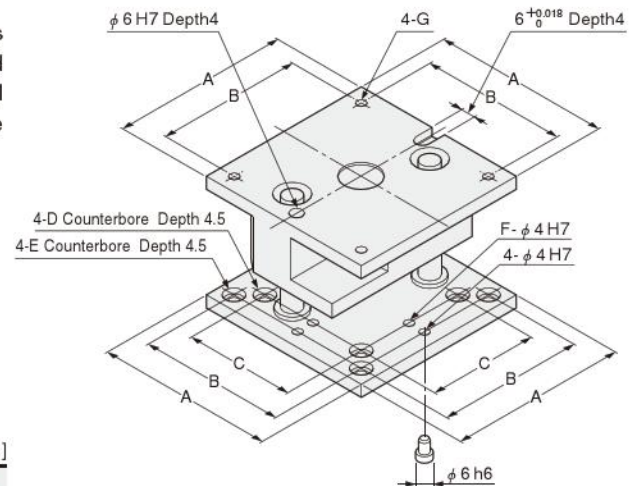

## Optimum load mass

For the Systematic Handling Module, use the load masses shown below as a guide.

- S size ..... 250g [8.82oz.]
- M size ..... 500g [17.64oz.]
- L size ..... 1000g [35.27oz.]

- To calculate the maximum load mass, use the formula below.

Robot load capacity	—	Hypothetical mass with all connected modules	—	Load ratio	=	Load mass
S size : 3kg [6.6lb.] M size : 6kg [13.2lb.] L size : 9kg [19.8lb.]		S size : 1.5kg [3.3lb.] M size : 3kg [6.6lb.] L size : 5kg [11.0lb.]				S size : 250g [8.82oz.] M size : 500g [17.64oz.] L size : 1000g [35.27oz.]

The leading runner on the automated line, the Handling Module  
**This will be the STANDARD from now on.**

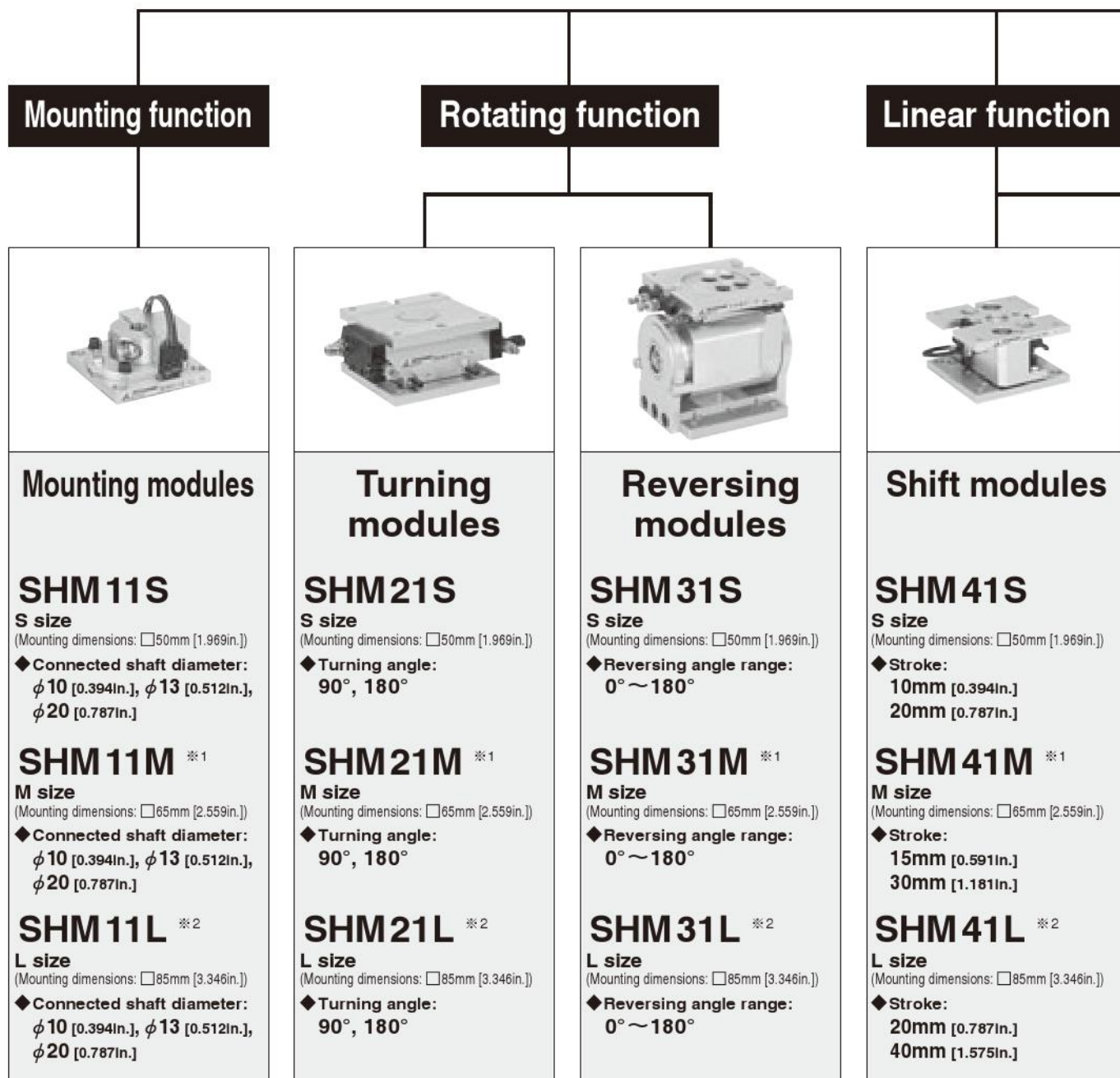

※1 : In addition to M size, S size mountings are also possible.

※2 : In addition to L size, M size mountings are also possible.

# Systematic HandlingModule

Positioning error correction function

Gripping function



## Cushion modules

### SHM51S

**S size**  
(Mounting dimensions: □50mm [1.969in.])

◆ **Stroke:**  
5mm [0.197in.]  
10mm [0.394in.]

### SHM51M <sup>※1</sup>

**M size**  
(Mounting dimensions: □65mm [2.559in.])

◆ **Stroke:**  
8mm [0.315in.]  
15mm [0.591in.]

### SHM51L <sup>※2</sup>

**L size**  
(Mounting dimensions: □85mm [3.346in.])

◆ **Stroke:**  
10mm [0.394in.]  
20mm [0.787in.]



## Compliance modules

### SHM61S, 62S

**S size**  
(Mounting dimensions: □50mm [1.969in.])

### SHM61M, 62M

**M size**  
(Mounting dimensions: □65mm [2.559in.])

### SHM61L, 62L

**L size**  
(Mounting dimensions: □85mm [3.346in.])



## Parallel clamping modules

### SHM71S

**S size**  
(Mounting dimensions: □50mm [1.969in.])

◆ **Gripping width:**  
42mm [1.65in.]

### SHM71M

**M size**  
(Mounting dimensions: □65mm [2.559in.])

◆ **Gripping width:**  
57mm [2.24in.]

### SHM71L

**L size**  
(Mounting dimensions: □85mm [3.346in.])

◆ **Gripping width:**  
73mm [2.87in.]



## Parallel clamping long modules

### SHM72S

**S size**  
(Mounting dimensions: □50mm [1.969in.])

◆ **Gripping width:**  
140, 240, 340mm  
[5.51, 9.45, 13.39in.]

### SHM72M

**M size**  
(Mounting dimensions: □65mm [2.559in.])

◆ **Gripping width:**  
176, 276, 376mm  
[6.93, 10.87, 14.80in.]

### SHM72L

**L size**  
(Mounting dimensions: □85mm [3.346in.])

◆ **Gripping width:**  
318, 418, 518mm  
[12.52, 16.46, 20.39in.]

● SHM62 is NZ specification.  
For details, see p.1521.

# PARALLEL CLAMPING MODULES

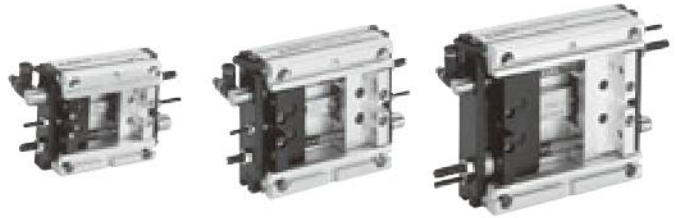

This module plays the role of fingers in the hand (gripper) unit. Because the cylinder operates asynchronously, it has superior positioning during clamping. It is particularly suitable for small workpieces.

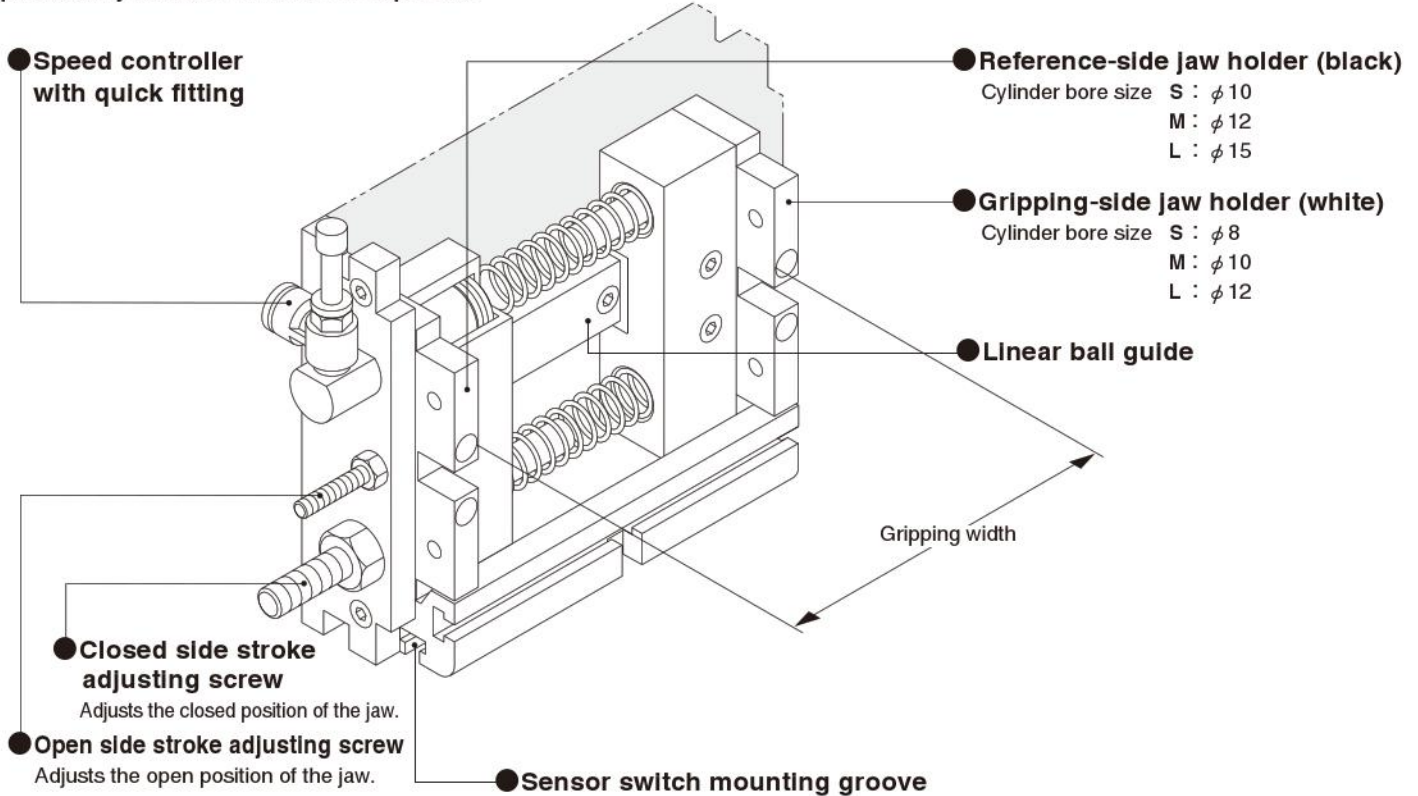

Note: Since loosening the connection screws will go out of the assembly precision, do not disassemble.

## Specifications

Model		SHM71S	SHM71M	SHM71L
Item	Mounting surface	S	M	L
Cylinder bore size	mm [in.]	8 [0.315] (10 [0.394])	10 [0.394] (12 [0.472])	12 [0.472] (15 [0.591])
Stroke	mm [in.]	One side 8 [0.315]	One side 12 [0.472]	One side 15 [0.591]
Media		Air		
Operating pressure range	MPa [psi.]	0.2~0.6 [29~87]		
Proof pressure	MPa [psi.]	1 [145]		
Operating temperature range	°C [°F]	0~60 [32~140]		
Operation type and mechanism		Normally open single acting type, asynchronous type, linear ball guide, with stroke adjusting mechanism		
Lubrication		Not required		
Gripping force <sup>Note</sup>	When open (Spring force)	2.5~6.9 [0.56~1.55]	3.9~12.7 [0.88~2.85]	5.1~12.9 [1.15~2.90]
	When closed	21.6—Spring force [4.9—Spring force]	33.3—Spring force [7.5—Spring force]	48.1—Spring force [10.8—Spring force]
Allowable moment	Pitching	100 [8.9]	210 [18.6]	460 [40.7]
	Yawing	120 [10.6]	240 [21.2]	540 [47.8]
	Rolling	160 [14.2]	290 [25.7]	980 [86.7]
Repeatability	mm [in.]	$\pm 0.01$ [ $\pm 0.0004$ ]		
Maximum operating frequency	cycle/min	40		
Sensor switches		Operation detection X2		
Gripping width	mm [in.]	26~42 [1.02~1.65]	33~57 [1.30~2.24]	43~73 [1.69~2.87]
Mass	g [oz.]	240 [8.5]	450 [15.9]	880 [31.0]

Note: Values at 0.5MPa [73psi.] air pressure.

## Order Codes

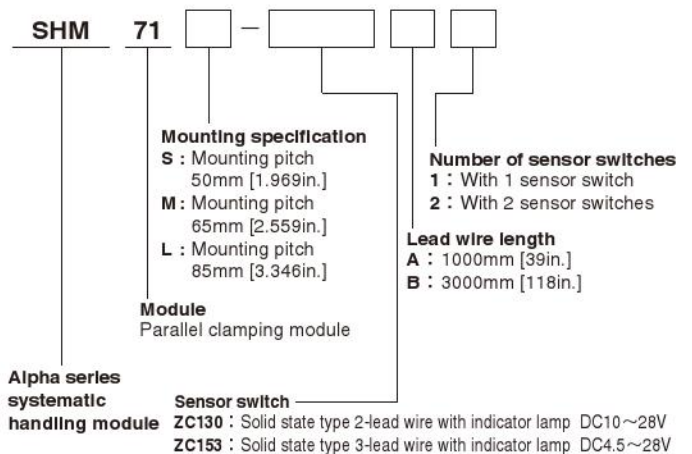

### Order codes for sensor switches only

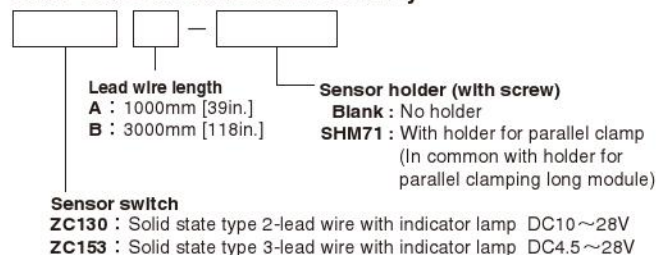

● For details of sensor switches, see p.1544.

# Dimensions of SHM71S, M, L (mm)

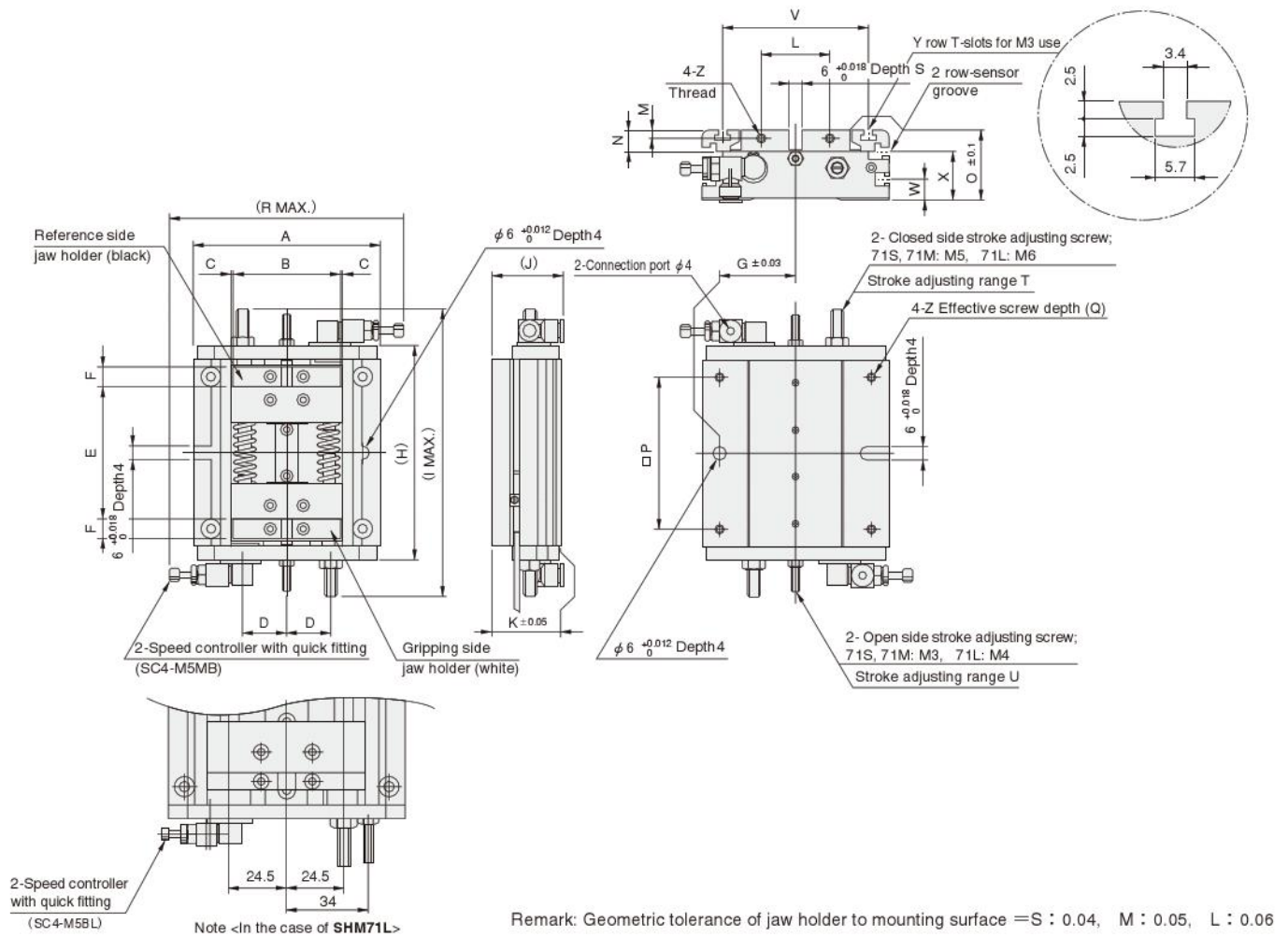
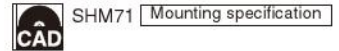

Code	A				E		F	G	H	I	J	K	L	M	N	O	P	Q	R	S	T	U	V	W	X	Y	Z
	A	B	C	D	Maximum when open	Minimum when closed																					
SHM71S	60	32	0.5	14.5	42	26	6	25.0	72	100	30	25	20	4	8	25	50	4	92	7	8	8	45	—	16	2	M4
SHM71M	80	46	1.0	18.5	57	33	8	32.5	92	122	32	30	30	4	9	30	65	7	100	8	10	10	60	8	21	4	M4
SHM71L	100	64	1.0	Note	73	43	8	42.5	112	155	34	35	40	5	10	35	85	8	110	8.5	15	15	78	10	23	4	M5

## Allowable Moment

Do not apply any moment exceeding the allowable values listed on p.1523.

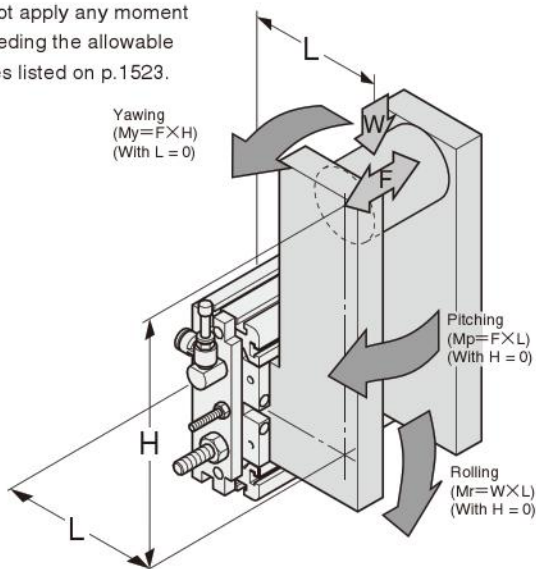

## Comparative Examples

As compared with more commonly used synchronous types, this module employs an asynchronous method (to obtain independent movement in each jaw). In addition, extended and retracted side stroke adjustment allows fine adjustment for workpieces. Since the cylinder bore size of the jaw on one side has been larger and works as a reference side for gripping, and along with the opposite side for slave jaw, it is optimum for gripping workpieces having its reference plane on the side.

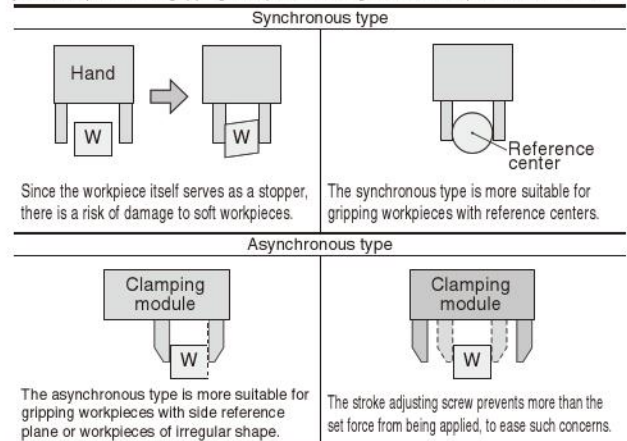

**Either single use or various combinations are possible.**

● **Application Example as Robotic Fingers**

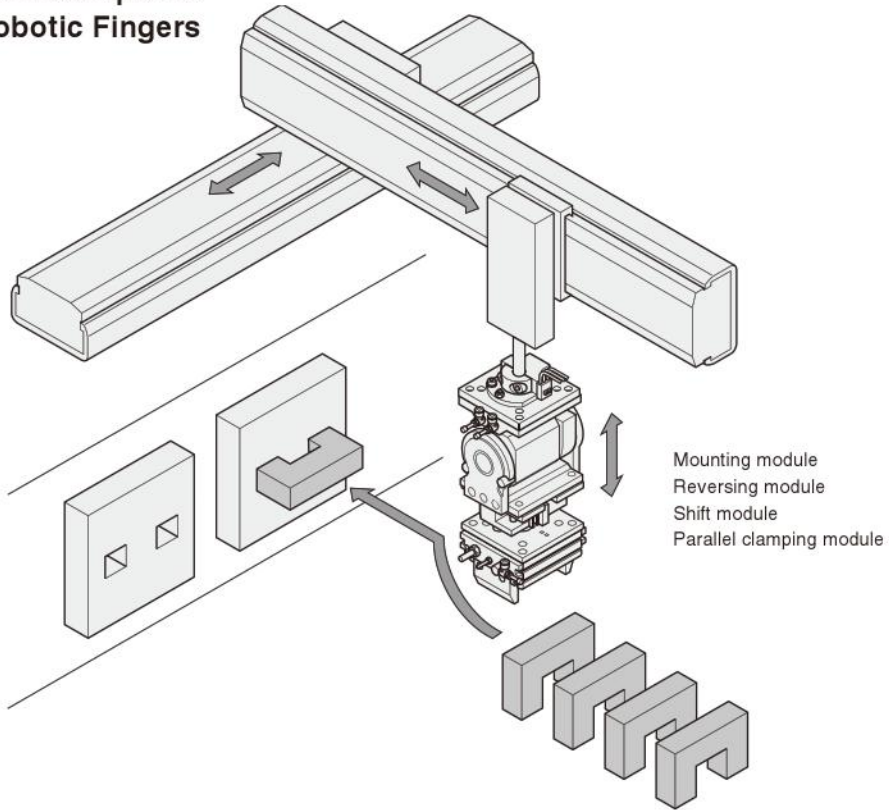

● **Application Example for Conveyor Line**

