

More precision



We have added advanced positioning precision and high rigidity to the pneumatic actuator.

The Koganei Alpha Series further enhances the drive module concept, supporting superior applications and labor savings in FA line design and manufacturing with higher performance.

Systematic Handling Module

The handling module has mounting, turning, linear motion, positioning error correction, and gripping functions, which serve to shorten the design time regarding the material handling process, to reduce costs, and to deliver performance for the early set-up of automated lines.

Standardized modules

The handling operation is classified, standardized, and modularized into 7 functions.

As a result, designers can immediately complete the handling unit by combining modules organized by functions.

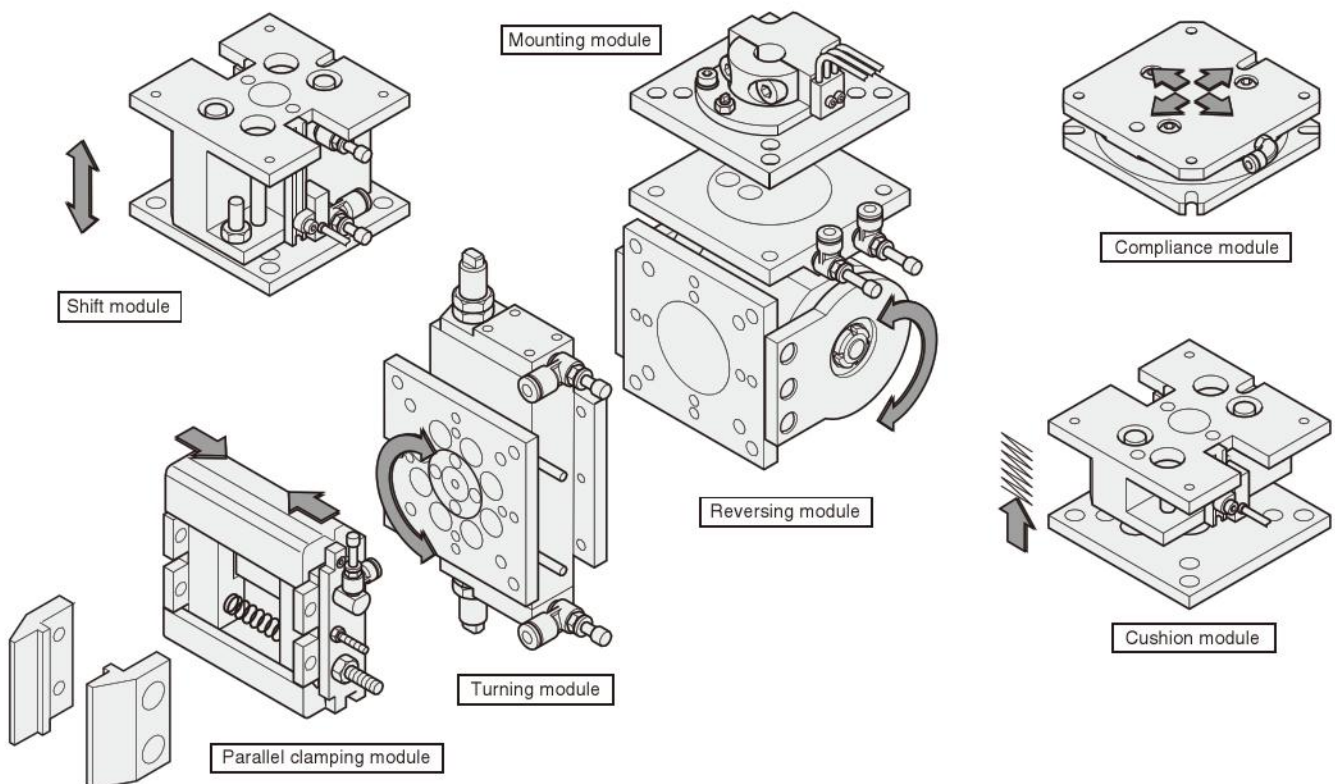

Assure high accuracy

High machining and assembly precision of the module ensure high accuracy in single-unit use or combination use.

Repeatability in each module	
Turning module	$\pm 0.03^\circ$
Reversing module	$\pm 0.03^\circ$
Shift module	$\pm 0.05\text{mm}$ [$\pm 0.0020\text{in.}$]
Cushion module	$\pm 0.05\text{mm}$ [$\pm 0.0020\text{in.}$]
Compliance module	$\pm 0.02\text{mm}$ [$\pm 0.0008\text{in.}$]
Parallel clamping module	$\pm 0.01\text{mm}$ [$\pm 0.0004\text{in.}$]

- Tolerance of the contact surface parallelism between mounting surface and mounted surface
=S : 0.04, M : 0.05, L : 0.06

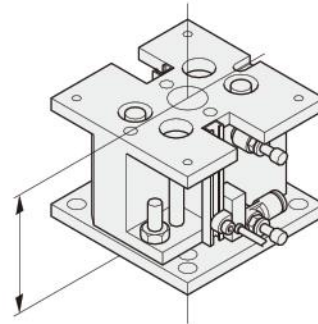

- Tolerance of the coaxiality with the hypothetical center, as restricted by the locating pin =S : $\phi 0.04$, M : $\phi 0.05$, L : $\phi 0.06$

Commonality of mounting pitch

● Full choice mounting method

The Systematic Handling Module is a standard module that provides handling operations in the precision assembly field by 7 classified functions, for a complete series. Moreover, the module uses the full choice mounting method that makes any combinations possible while keeping the excellent positioning accuracy.

Features

- ① Common mounting dimensions for each size
- ② Bottom surfaces can be used to mount the same size or one smaller sized module.
- ③ To ensure accurate positioning of the handling modules, there are dowel pin holes on contacted surface of each modules, and locating pins are available (2 locating pins supplied with each module, with the exception of the parallel clamping module).

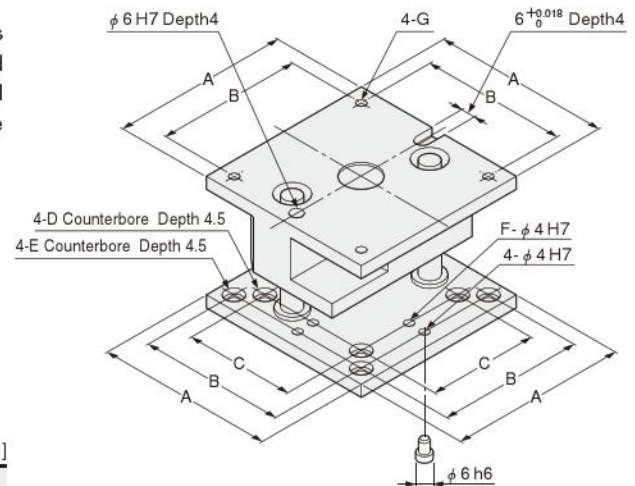

	mm [in.]						
	A	B	C	D	E	F	G
S size	60 [2.362]	50 [1.969]	—	—	M4	—	M4
M size	80 [3.150]	65 [2.559]	50 [1.969]	M4	M4	4 [0.157]	M5
L size	100 [3.937]	85 [3.346]	65 [2.559]	M4	M5		

Optimum load mass

For the Systematic Handling Module, use the load masses shown below as a guide.

- S size 250g [8.82oz.]
- M size 500g [17.64oz.]
- L size 1000g [35.27oz.]

- To calculate the maximum load mass, use the formula below.

Robot load capacity	—	Hypothetical mass with all connected modules	—	Load ratio	=	Load mass
S size : 3kg [6.6lb.] M size : 6kg [13.2lb.] L size : 9kg [19.8lb.]		S size : 1.5kg [3.3lb.] M size : 3kg [6.6lb.] L size : 5kg [11.0lb.]				S size : 250g [8.82oz.] M size : 500g [17.64oz.] L size : 1000g [35.27oz.]

The leading runner on the automated line, the Handling Module
This will be the STANDARD from now on.

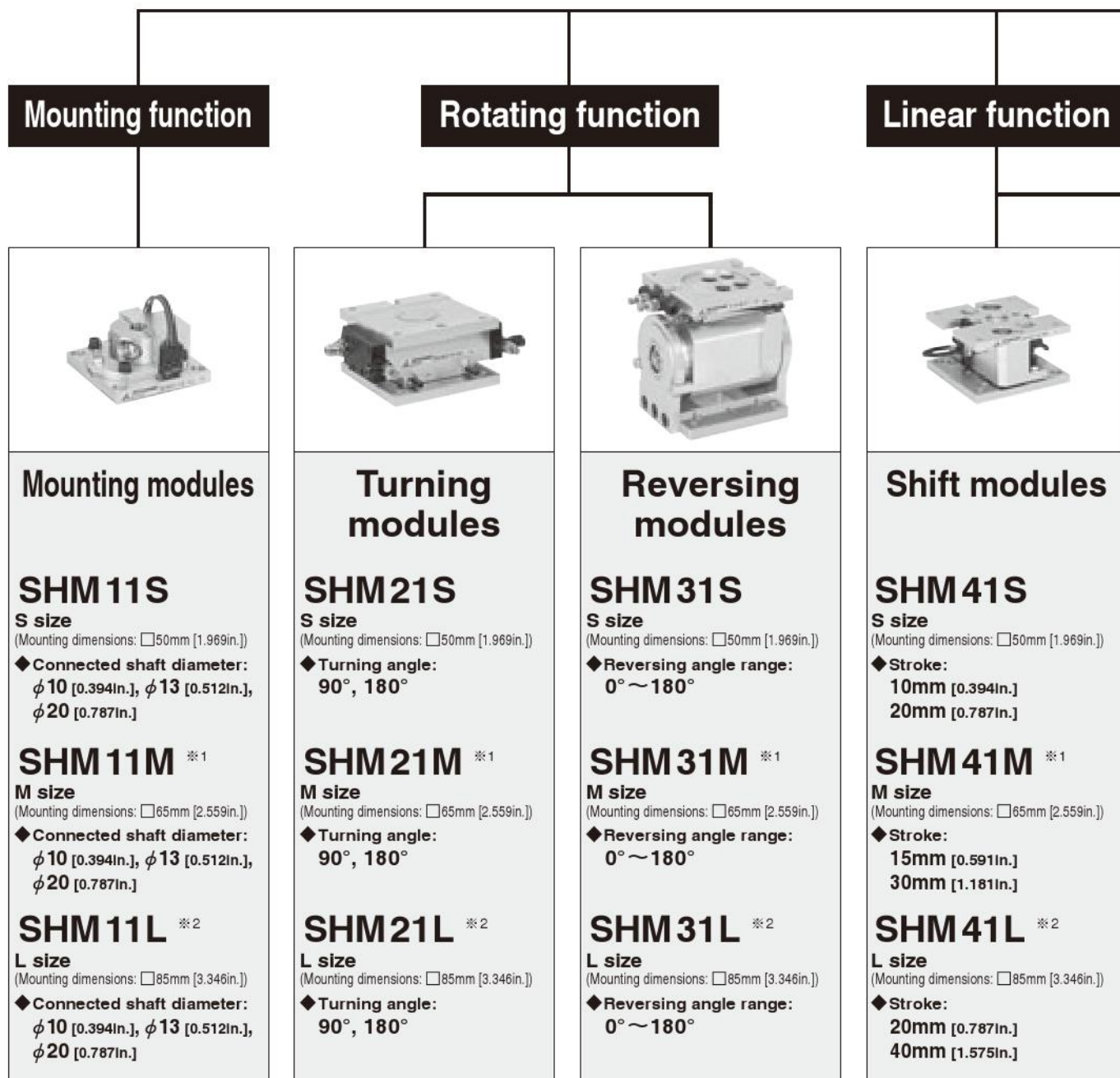

※1 : In addition to M size, S size mountings are also possible.

※2 : In addition to L size, M size mountings are also possible.

Systematic HandlingModule

Positioning error correction function

Gripping function



Cushion modules

SHM51S

S size
(Mounting dimensions: □50mm [1.969in.])

◆ **Stroke:**
5mm [0.197in.]
10mm [0.394in.]

SHM51M ^{※1}

M size
(Mounting dimensions: □65mm [2.559in.])

◆ **Stroke:**
8mm [0.315in.]
15mm [0.591in.]

SHM51L ^{※2}

L size
(Mounting dimensions: □85mm [3.346in.])

◆ **Stroke:**
10mm [0.394in.]
20mm [0.787in.]



Compliance modules

SHM61S, 62S

S size
(Mounting dimensions: □50mm [1.969in.])

SHM61M, 62M

M size
(Mounting dimensions: □65mm [2.559in.])

SHM61L, 62L

L size
(Mounting dimensions: □85mm [3.346in.])



Parallel clamping modules

SHM71S

S size
(Mounting dimensions: □50mm [1.969in.])

◆ **Gripping width:**
42mm [1.65in.]

SHM71M

M size
(Mounting dimensions: □65mm [2.559in.])

◆ **Gripping width:**
57mm [2.24in.]

SHM71L

L size
(Mounting dimensions: □85mm [3.346in.])

◆ **Gripping width:**
73mm [2.87in.]



Parallel clamping long modules

SHM72S

S size
(Mounting dimensions: □50mm [1.969in.])

◆ **Gripping width:**
140, 240, 340mm
[5.51, 9.45, 13.39in.]

SHM72M

M size
(Mounting dimensions: □65mm [2.559in.])

◆ **Gripping width:**
176, 276, 376mm
[6.93, 10.87, 14.80in.]

SHM72L

L size
(Mounting dimensions: □85mm [3.346in.])

◆ **Gripping width:**
318, 418, 518mm
[12.52, 16.46, 20.39in.]

● SHM62 is NZ specification.
For details, see p.1521.

COMPLIANCE MODULES

NZ Specification



This compliance module eliminates positioning error correction in the Z and α directions, and reduces galling during workpieces insertion.

Operation principles

1. The frame and plate enclose rolling steel balls, which move freely under the light centripetal force of the restraining ring and spring.
2. Applying air pressure pushes the inner plate down, to lock it into the determined reference position with the locating steel ball.

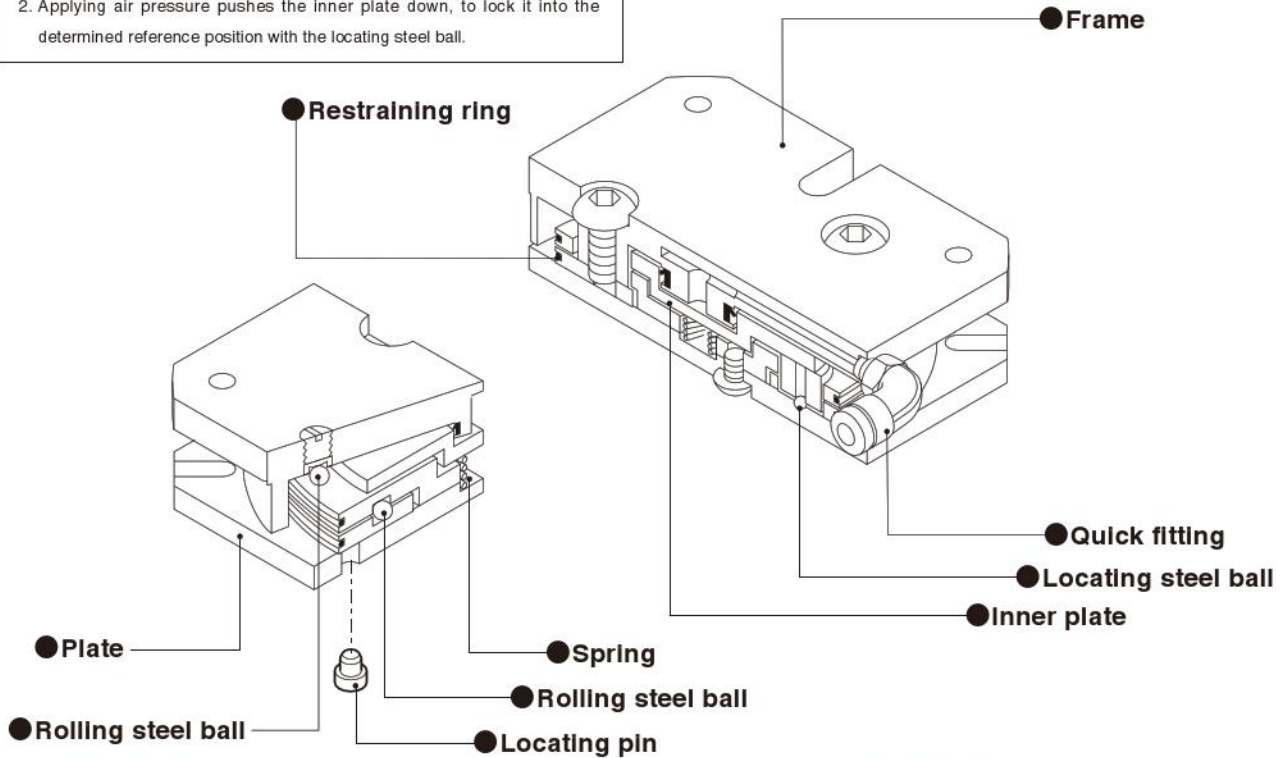

Note: Since loosening the connection screws will go out of the assembly precision, do not disassemble.

(Apply locking adhesive and insert it into the required hole.)

Specifications

Item		Model		
		SHM 62S	SHM 62M	SHM 62L
Mounting specification	Mounting surface	S	M	L
	Mounted surface	S	M	L
Media		Air		
Operating pressure range		MPa [psi] 0.2~0.6 [29~87]		
Proof pressure		MPa [psi] 1 [145]		
Operating temperature range		°C [°F] 0~60 [32~140]		
Operation type and mechanism		Horizontal passive type, with locking mechanism ^{Note}		
Lubrication		Not required		
Load mass		kg [lb.] 1.5 [3.3]	3 [6.6]	4.5 [9.9]
Movement range	X·Y	mm [in.] ±1.0 [±0.039]		
	Z	mm [in.] —		
	θ	° ±2.5°		
	α	—		
Centripetal force		N [lbf.] 5 [1.1]		
Repeatability when locked		mm [in.] ±0.02 [±0.0008]		
Mass		g [oz.] 200 [7.1]	420 [14.8]	600 [21.2]

Note: Applying air pressure brings it into a locked state.

Order Codes

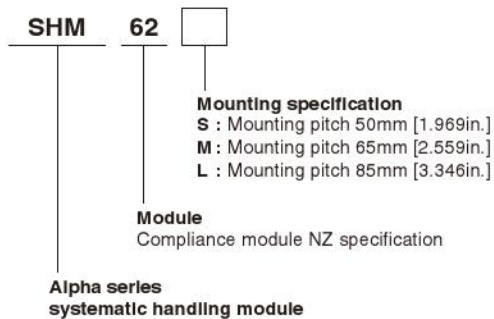

※ Two locating pins are included.

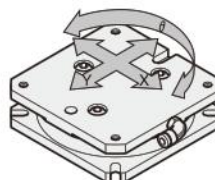

Moving directions of NZ specification
 Moves in the X, Y, and θ directions, as shown in the diagram to the left.

Dimensions of SHM62S, M, L (mm)

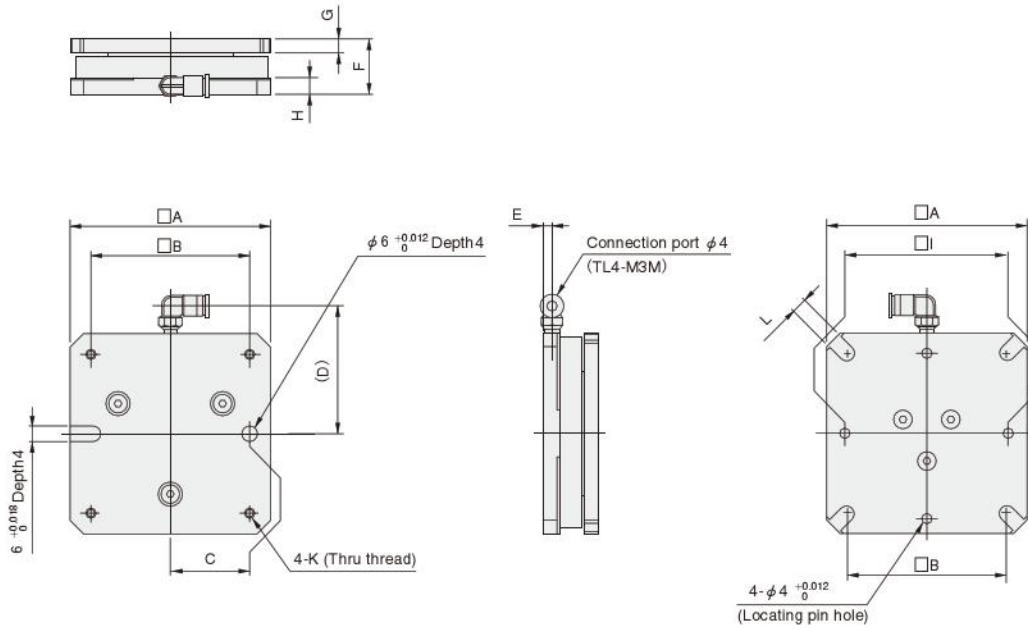

- Remarks: 1. Tolerance of the contact surface parallelism between mounting surface and mounted surface = S : 0.04, M : 0.05, L : 0.06
 2. Coaxiality tolerance with the hypothetical center, as restricted by the locating pin = S : $\phi 0.04$, M : $\phi 0.05$, L : $\phi 0.06$

Code Model	A	B	C	D	E	F	G	H	I	K	L
SHM 62S	60	50	25.0	42	3	20	4	5.5	50 ± 0.03	M4	4.5
SHM 62M	80	65	32.5	52	3	23	5	6.0	65 ± 0.03	M4	4.5
SHM 62L	100	85	42.5	62	3.5	28	7	7.0	85 ± 0.05	M5	5.5

Either single use or various combinations are possible.

● **Application Example as Robotic Fingers**

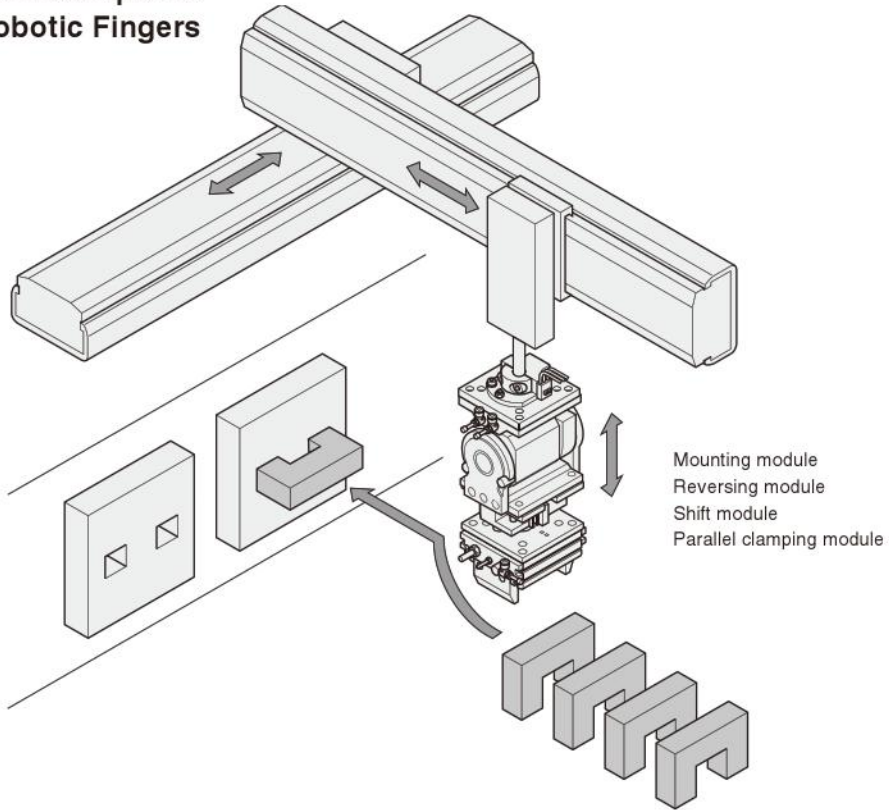

● **Application Example for Conveyor Line**

