

More precision



We have added advanced positioning precision and high rigidity to the pneumatic actuator.

The Koganei Alpha Series further enhances the drive module concept, supporting superior applications and labor savings in FA line design and manufacturing with higher performance.

Systematic Handling Module

The handling module has mounting, turning, linear motion, positioning error correction, and gripping functions, which serve to shorten the design time regarding the material handling process, to reduce costs, and to deliver performance for the early set-up of automated lines.

Standardized modules

The handling operation is classified, standardized, and modularized into 7 functions.

As a result, designers can immediately complete the handling unit by combining modules organized by functions.

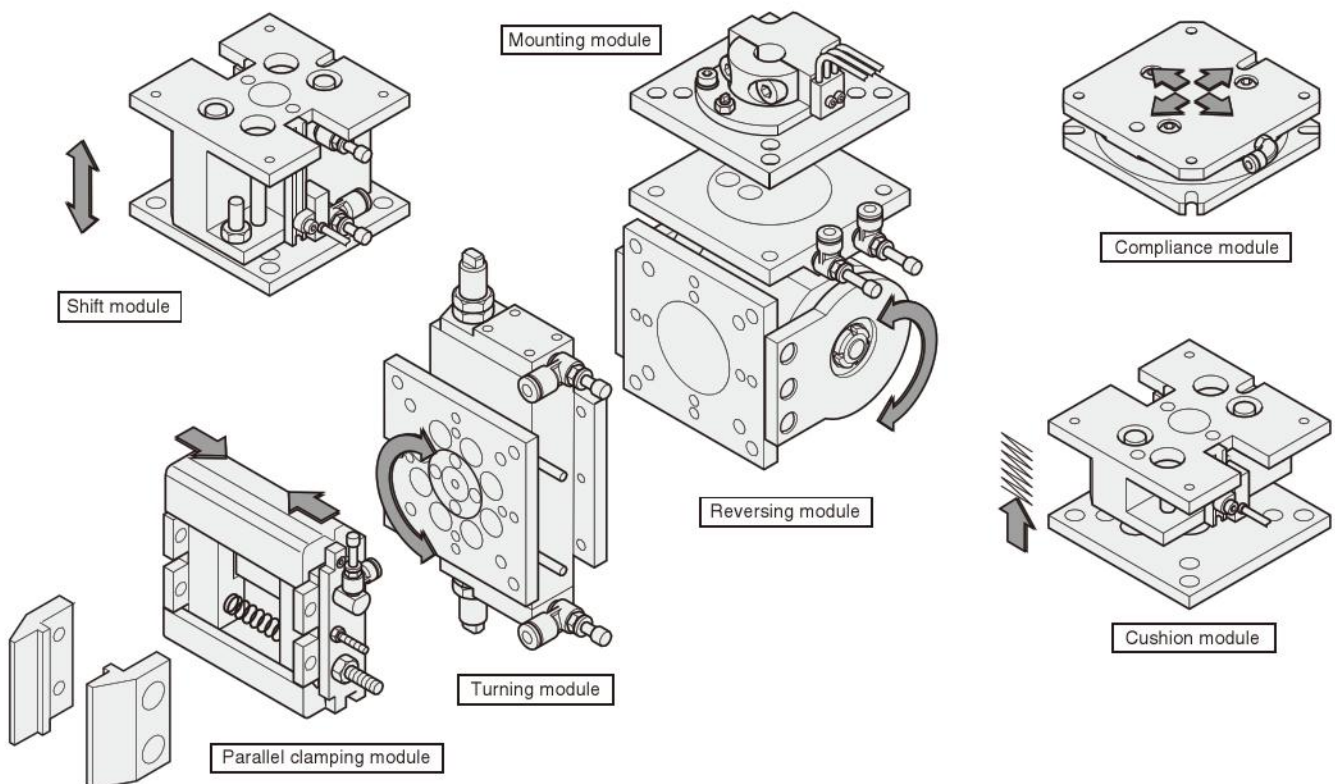

Assure high accuracy

High machining and assembly precision of the module ensure high accuracy in single-unit use or combination use.

Repeatability in each module	
Turning module	$\pm 0.03^\circ$
Reversing module	$\pm 0.03^\circ$
Shift module	$\pm 0.05\text{mm}$ [$\pm 0.0020\text{in.}$]
Cushion module	$\pm 0.05\text{mm}$ [$\pm 0.0020\text{in.}$]
Compliance module	$\pm 0.02\text{mm}$ [$\pm 0.0008\text{in.}$]
Parallel clamping module	$\pm 0.01\text{mm}$ [$\pm 0.0004\text{in.}$]

- Tolerance of the contact surface parallelism between mounting surface and mounted surface
=S : 0.04, M : 0.05, L : 0.06

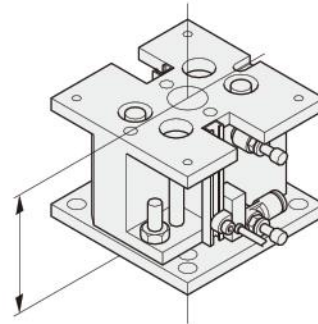

- Tolerance of the coaxiality with the hypothetical center, as restricted by the locating pin =S : $\phi 0.04$, M : $\phi 0.05$, L : $\phi 0.06$

Commonality of mounting pitch

● Full choice mounting method

The Systematic Handling Module is a standard module that provides handling operations in the precision assembly field by 7 classified functions, for a complete series. Moreover, the module uses the full choice mounting method that makes any combinations possible while keeping the excellent positioning accuracy.

Features

- ① Common mounting dimensions for each size
- ② Bottom surfaces can be used to mount the same size or one smaller sized module.
- ③ To ensure accurate positioning of the handling modules, there are dowel pin holes on contacted surface of each modules, and locating pins are available (2 locating pins supplied with each module, with the exception of the parallel clamping module).

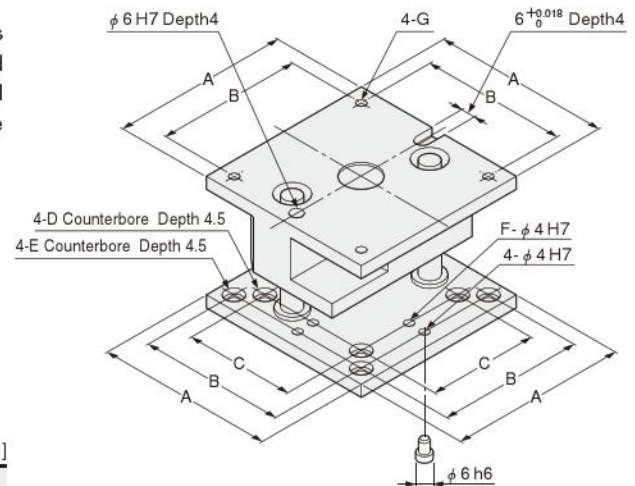

	mm [in.]						
	A	B	C	D	E	F	G
S size	60 [2.362]	50 [1.969]	—	—	M4	—	M4
M size	80 [3.150]	65 [2.559]	50 [1.969]	M4	M4	4 [0.157]	M5
L size	100 [3.937]	85 [3.346]	65 [2.559]	M4	M5		

Optimum load mass

For the Systematic Handling Module, use the load masses shown below as a guide.

- S size 250g [8.82oz.]
- M size 500g [17.64oz.]
- L size 1000g [35.27oz.]

- To calculate the maximum load mass, use the formula below.

Robot load capacity	—	Hypothetical mass with all connected modules	—	Load ratio	=	Load mass
S size : 3kg [6.6lb.] M size : 6kg [13.2lb.] L size : 9kg [19.8lb.]		S size : 1.5kg [3.3lb.] M size : 3kg [6.6lb.] L size : 5kg [11.0lb.]				S size : 250g [8.82oz.] M size : 500g [17.64oz.] L size : 1000g [35.27oz.]

The leading runner on the automated line, the Handling Module
This will be the STANDARD from now on.

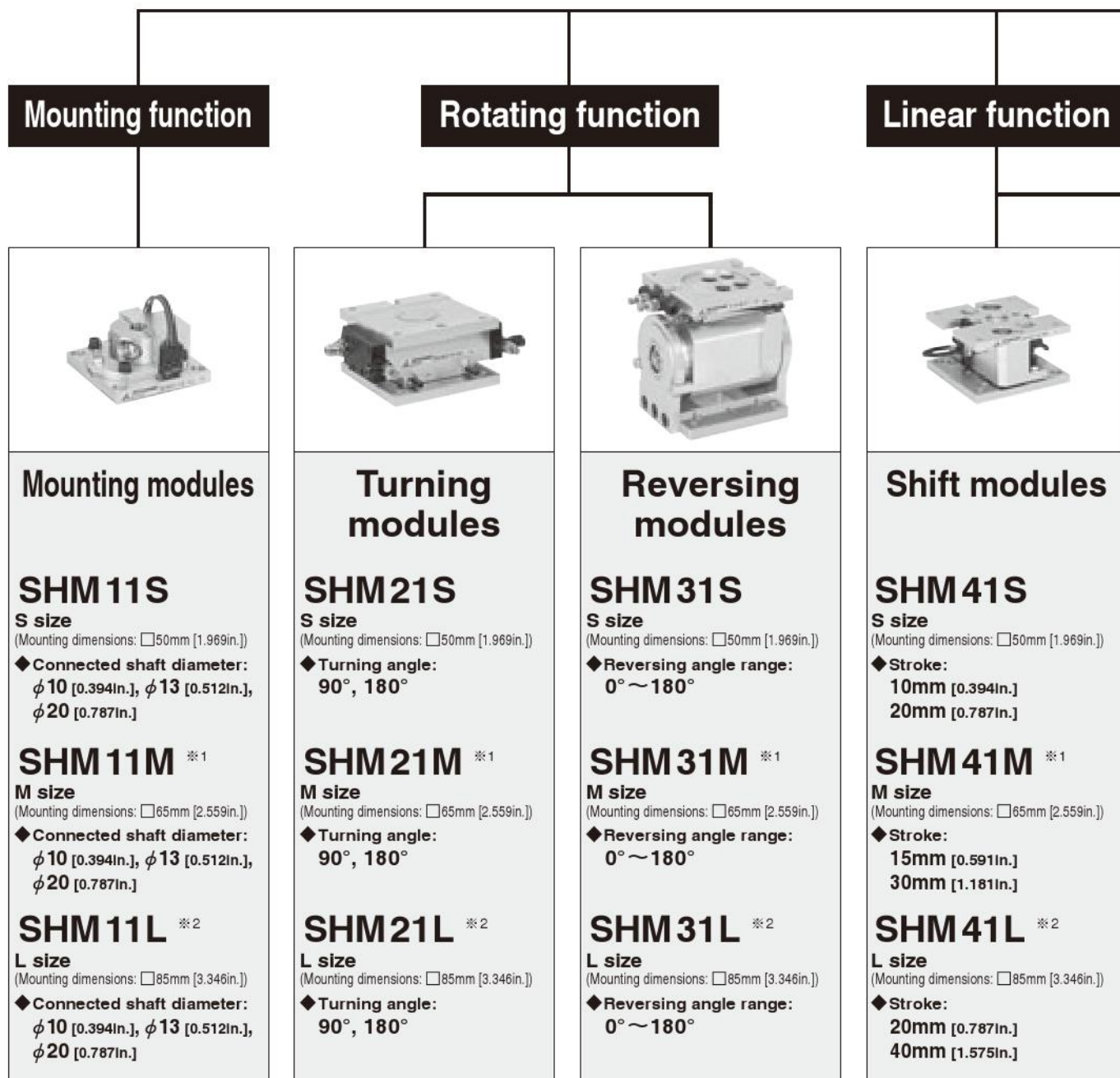

※1 : In addition to M size, S size mountings are also possible.

※2 : In addition to L size, M size mountings are also possible.

Systematic HandlingModule

Positioning error correction function

Gripping function



Cushion modules

SHM51S

S size
(Mounting dimensions: □50mm [1.969in.])

◆ **Stroke:**
5mm [0.197in.]
10mm [0.394in.]

SHM51M ^{※1}

M size
(Mounting dimensions: □65mm [2.559in.])

◆ **Stroke:**
8mm [0.315in.]
15mm [0.591in.]

SHM51L ^{※2}

L size
(Mounting dimensions: □85mm [3.346in.])

◆ **Stroke:**
10mm [0.394in.]
20mm [0.787in.]



Compliance modules

SHM61S, 62S

S size
(Mounting dimensions: □50mm [1.969in.])

SHM61M, 62M

M size
(Mounting dimensions: □65mm [2.559in.])

SHM61L, 62L

L size
(Mounting dimensions: □85mm [3.346in.])



Parallel clamping modules

SHM71S

S size
(Mounting dimensions: □50mm [1.969in.])

◆ **Gripping width:**
42mm [1.65in.]

SHM71M

M size
(Mounting dimensions: □65mm [2.559in.])

◆ **Gripping width:**
57mm [2.24in.]

SHM71L

L size
(Mounting dimensions: □85mm [3.346in.])

◆ **Gripping width:**
73mm [2.87in.]



Parallel clamping long modules

SHM72S

S size
(Mounting dimensions: □50mm [1.969in.])

◆ **Gripping width:**
140, 240, 340mm
[5.51, 9.45, 13.39in.]

SHM72M

M size
(Mounting dimensions: □65mm [2.559in.])

◆ **Gripping width:**
176, 276, 376mm
[6.93, 10.87, 14.80in.]

SHM72L

L size
(Mounting dimensions: □85mm [3.346in.])

◆ **Gripping width:**
318, 418, 518mm
[12.52, 16.46, 20.39in.]

● SHM62 is NZ specification.
For details, see p.1521.

REVERSING MODULES



The module reverses the hand (gripper) unit within a range of 0° to 180°.

● Shock absorber

(Used also as the reversing angle adjusting screw.)
Screw in the shock absorber up to the set reversing angle adjusting position.

● Angular bearing

(One bearing is arranged on each end)

● Reversing shaft

(Vane rod)

● Stopper

Change the screwed position to align with the set reversing angle.
(Apply locking adhesive to tighten for locking.)

● Speed controller with quick fitting

The reversing speed can be adjusted.
(Be aware to avoid exceeding the operating speed range.)

● Magnet holder

Loosening the M3 setscrew allows the plate to move in a circumferential direction.
Adjust the mounting position so that the sensor switch operates at a required position.

● Reversing body

(Vane type rotary actuator)

Note: Since loosening the connection screws will go out of the assembly precision, do not disassemble.

Specifications

Item		Model		
		SHM31S	SHM31M	SHM31L
Mounting specification	Mounting surface	S	M	L
	Mounted surface	S	M or S ^{Note1}	L or M ^{Note2}
Media		Air		
Operating pressure range		MPa [psi]		
		0.2~0.6 [29~87]		
Proof pressure		MPa [psi]		
		1 [145]		
Operating temperature range		°C [°F]		
		0~60 [32~140]		
Operation type and mechanism		Double acting type, vane drive, with shock absorber, with reversing angle adjusting mechanism		
Lubrication		Not required		
Reversing angle range		0°~180°		
Adjusting angle range		0°~180°		
Effective torque ^{Note3}		N·cm [in·lbf]		
		74 [6.5]	294 [26.0]	490 [43.4]
Shock absorber		KSHAH6×3	KSHAH6×4	KSHAH6×5
Allowable moment		N·cm [in·lbf]		
		60 [5.3]	120 [10.6]	240 [21.2]
Allowable energy		J [ft·lbf]		
		0.25 [0.18]	0.88 [0.65]	1.39 [1.03]
Turning angle repeatability		±0.03°		
Operating speed range		Degrees/s		
		60~180		
Sensor switches		Operation detection×2		
Mass		g [oz.]		
		440 [15.5]	960 [33.9]	1880 [66.3]

Notes: 1. Both M and S sizes can be mounted on SHM31M.
2. Both L and M sizes can be mounted on SHM31L.
3. Values at 0.5MPa [73psi.] air pressure. The recommended torque for operation is about 50% of the effective torque.

Order Codes

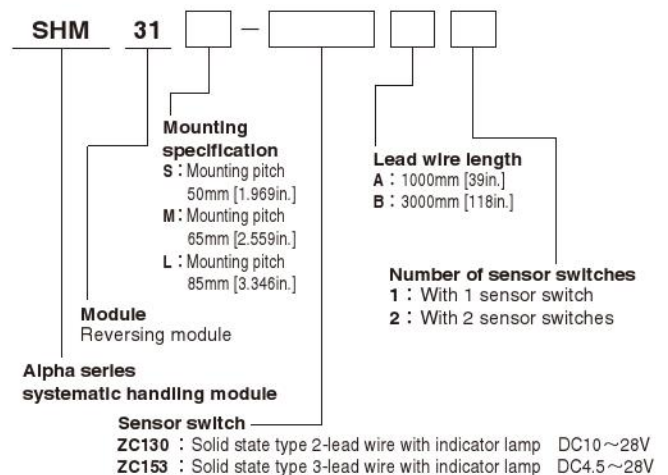

※ Two locating pins are included.

Order codes for sensor switches only

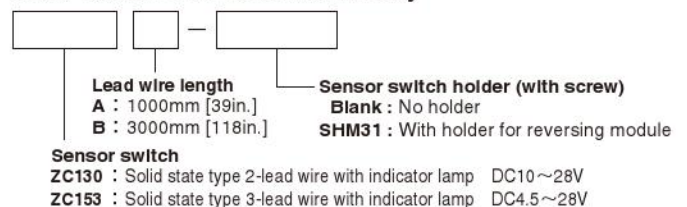

● For details of sensor switches, see p.1544.

Dimensions of SHM31S, M, L (mm)

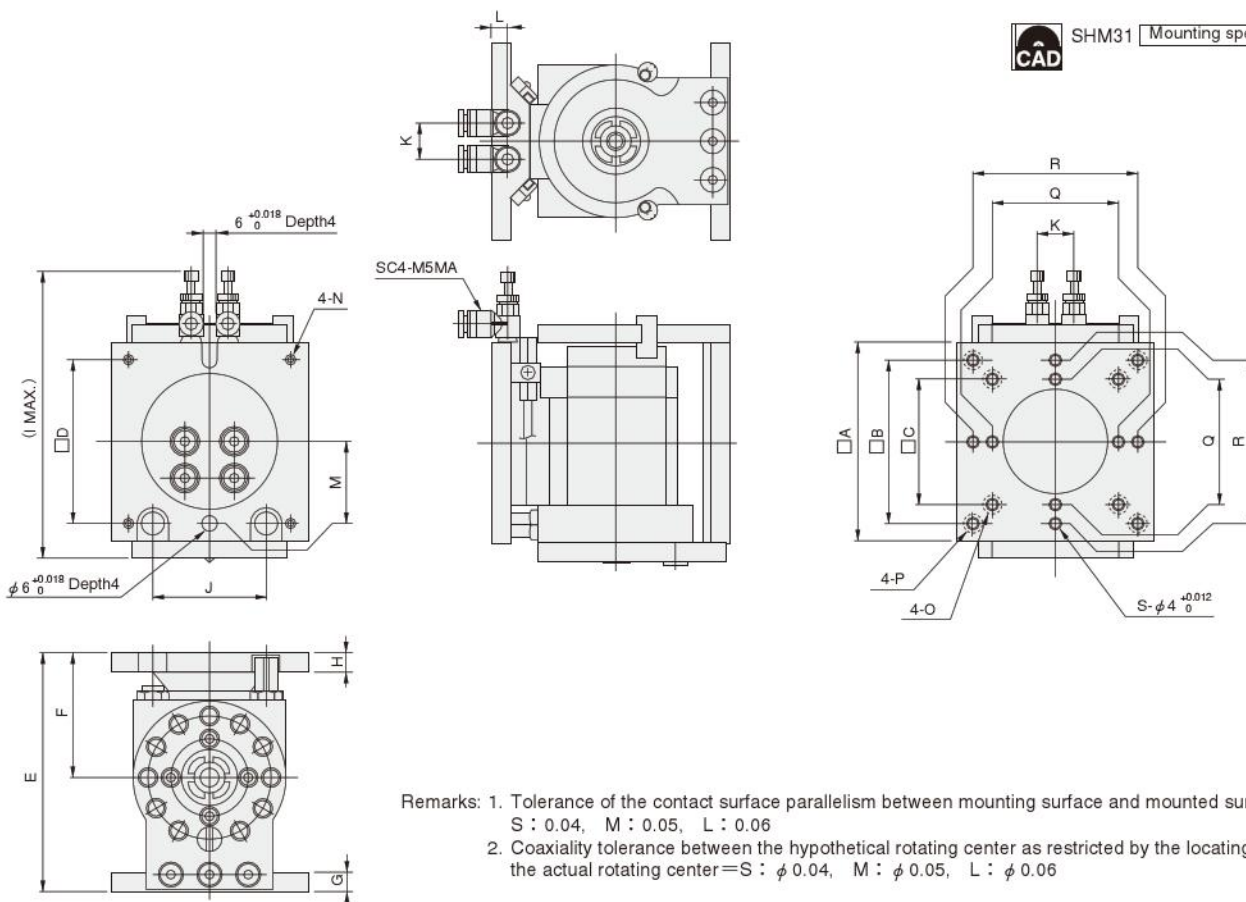

Remarks: 1. Tolerance of the contact surface parallelism between mounting surface and mounted surface = S : 0.04, M : 0.05, L : 0.06
 2. Coaxiality tolerance between the hypothetical rotating center as restricted by the locating pin and the actual rotating center = S : φ 0.04, M : φ 0.05, L : φ 0.06

Code	A	B	C	D	E	F	G	H	I	J	K	L	M	N	O	P	Q	R	S
SHM31S	60	50	—	50	75	40	6	6	96	29	13	7	25.0	M4	—	φ4.5, φ8 Counterbore Depth 4.5	—	50±0.03	4
SHM31M	80	65	50	65	95	50	7	7	117	46	15	7	32.5	M4	φ4.5, φ8 Counterbore Depth 4.4	φ4.5, φ8 Counterbore Depth 4.5	50±0.03	65±0.03	8
SHM31L	100	85	65	85	115	60	8	8	138	51	20	7	42.5	M5	φ4.5, φ8 Counterbore Depth 4.4	φ5.5, φ9.5 Counterbore Depth 5.4	65±0.03	85±0.05	8

Internal Capacity and Air Consumption

Internal capacity

- SHM31S : 9cm³ [0.55in.³]
- SHM31M : 43cm³ [2.62in.³]
- SHM31L : 75cm³ [4.58in.³]

$$\text{Air consumption } Q = v \cdot \frac{(P_1 + 1.033)}{1.033} \cdot n$$

- Q : Air consumption cc (cm³)/min (ANR)
- v : Internal capacity of reversing module cc (cm³)
- n : Operating frequency times/min
- P₁ : Pressure kgf/cm²

$$\text{Air consumption } Q' = v' \cdot \frac{(P'_1 + 14.696)}{14.696} \cdot n$$

- Q' : Air consumption in.³/min. (ANR)**
- v' : Internal capacity of reversing module in.³
- n : Operating frequency times/min.
- P'₁ : Pressure psi.

**Refer to p.54 for an explanation of ANR.

Allowable Moment

Do not apply the moment (M=F×L) exceeding the allowable values listed on p.1513.

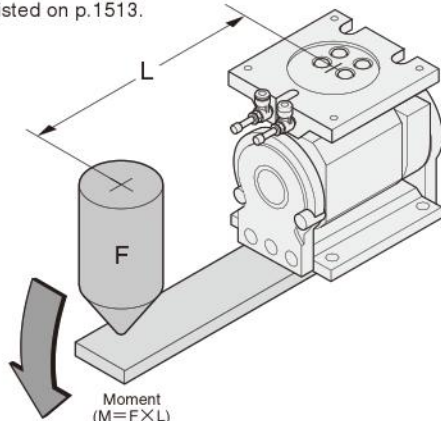

Mounting Sensor Switch

Mount the sensor switch laterally in the sensor holder so that the model marking surface faces upward, as shown below.

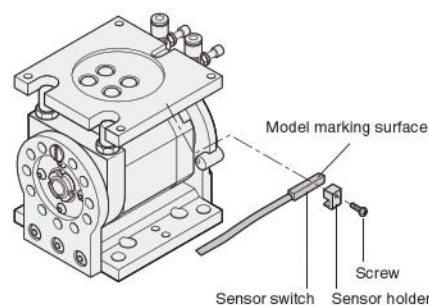

SHOCK ABSORBERS

Specifications

● KSHA Series for Turning Module

Basic model	KSHA6×5-D	KSHA6×5-DE	KSHA6×8-F
Item			
Maximum absorption J [ft·lbf]	1.0 [0.74]	1.5 [1.11]	2.9 [2.14]
Maximum impact speed m/s [ft./sec.]	1.0 [3.28]		
Maximum operating frequency cycle/min	60		30
Absorbing stroke mm [in.]	5 [0.197]	8 [0.315]	
Operating temperature range °C [°F]	0~60 [32~140]		
Mass g [oz.]	10 [0.35]	20 [0.71]	

● KSHAH Series for Reversing Module

Basic model	KSHAH6×3	KSHAH6×4	KSHAH6×5
Item			
Maximum absorption J [ft·lbf]	0.3 [0.22]	0.9 [0.66]	1.4 [1.03]
Maximum impact speed m/s [ft./sec.]	0.1 [0.33]		
Maximum operating frequency cycle/min	60		
Absorbing stroke mm [in.]	3 [0.118]	4 [0.157]	5 [0.197]
Operating temperature range °C [°F]	0~60 [32~140]		
Mass g [oz.]	14 [0.49]	18 [0.63]	22 [0.78]

Dimensions (mm)

● KSHA

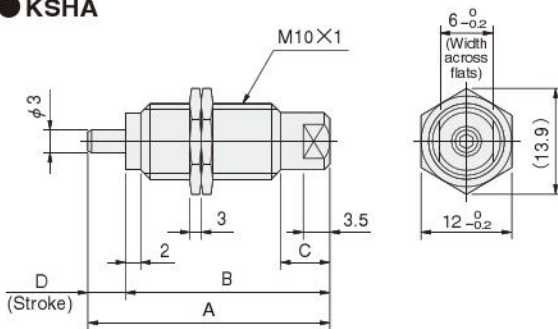

Model	A	B	C	D
KSHA6×5-D	30.5	25.5	7	5
KSHA6×5-DE				
KSHA6×8-F	48	40	10	8

● KSHAH

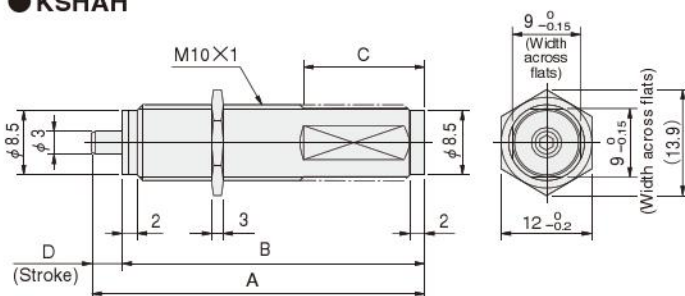

Model	A	B	C	D
KSHAH6×3	33	30	16	3
KSHAH6×4	44	40		4
KSHAH6×5	53	48	22	5

Either single use or various combinations are possible.

● **Application Example as Robotic Fingers**

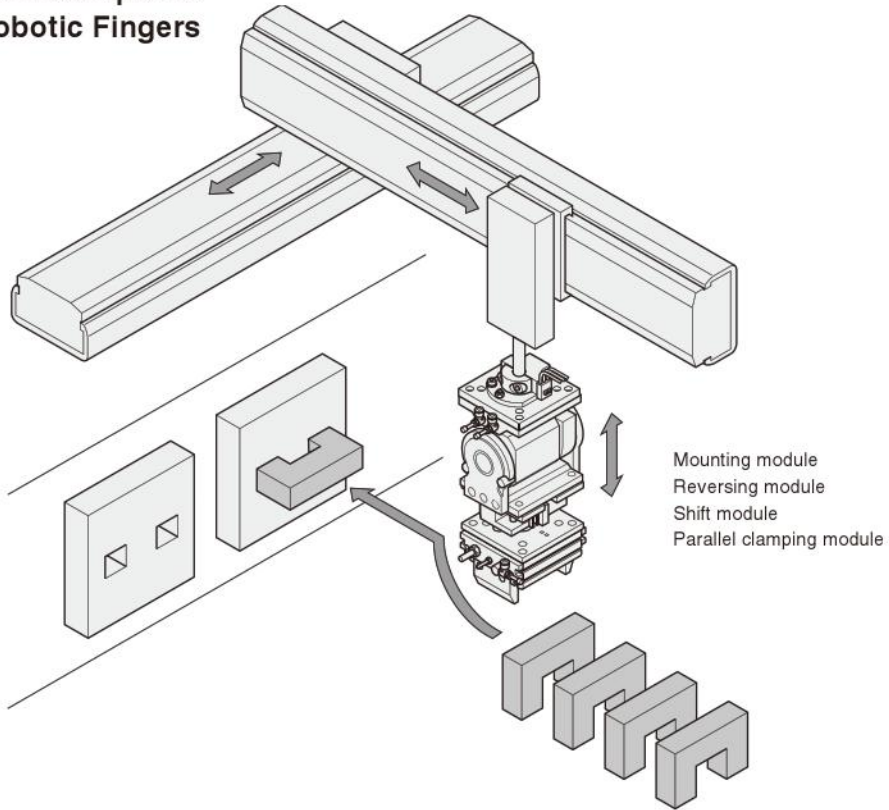

● **Application Example for Conveyor Line**

