

*Square, thin body allows selection of mounting and piping direction, and expands flexibility of device design.*

# JIG CYLINDERS WITH GUIDES

## $\phi 12 \sim \phi 63$

### ■ Select guide rod bearing according to application

Wide range includes scraper specification to prevent dust from entering.

#### 1. Slide bearing type

Superior wear resistance makes it optimum for stopper or other devices needing resistance to lateral loads with shocks.

#### 2. Rolling bearing type

Smooth operation with high precision makes it optimum for pushers and lifters.

### ■ Enables piping from 2 directions

Rational device design allows selection of piping location according to the mounting environment. In addition, the piping for dust collection ports used in cylinders for clean systems can also be approached from 2 directions.

### ■ Cylinders for clean systems also in line-up

Cleanliness rating corresponds to Class 5 (FED-STD209E Class 100 equivalent) (according to Koganei test standards).

### ■ Slender-figured sensor switch

Magnets for sensor switches are standard on all models. Embedded shape avoids protrusion of switches, to simplify mounting in tight spaces.

### ■ End keep cylinder also available

End keep mechanism supports stable operation in the vertical direction to prevent workpiece from falling caused by shut off in the air supply or any decrease of air pressure.

### ■ Four types of mounting possible

### ■ Non-ion as a Standard

Can be used on Cathode-ray tube (CRT) manufacturing lines, etc., since copper materials are not used. (Except cylinders for clean systems)

#### ● T-slot mounting groove

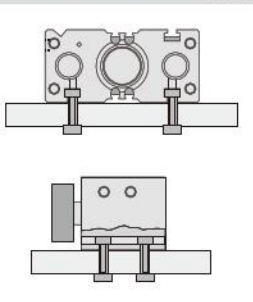

#### ● Sensor switch mounting groove

#### ● Top mounting

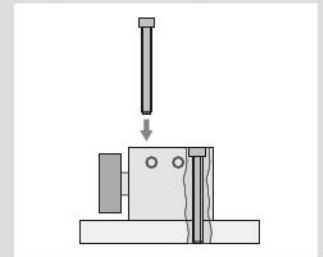

#### ● Bottom mounting

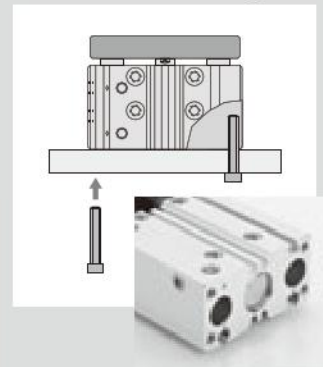

#### ● Upper piping

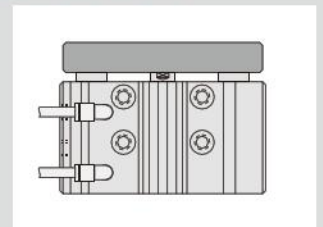

#### ● Side piping

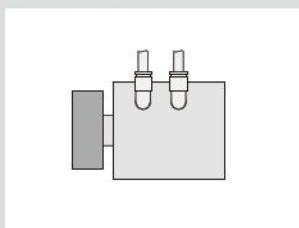

#### ● Side mounting

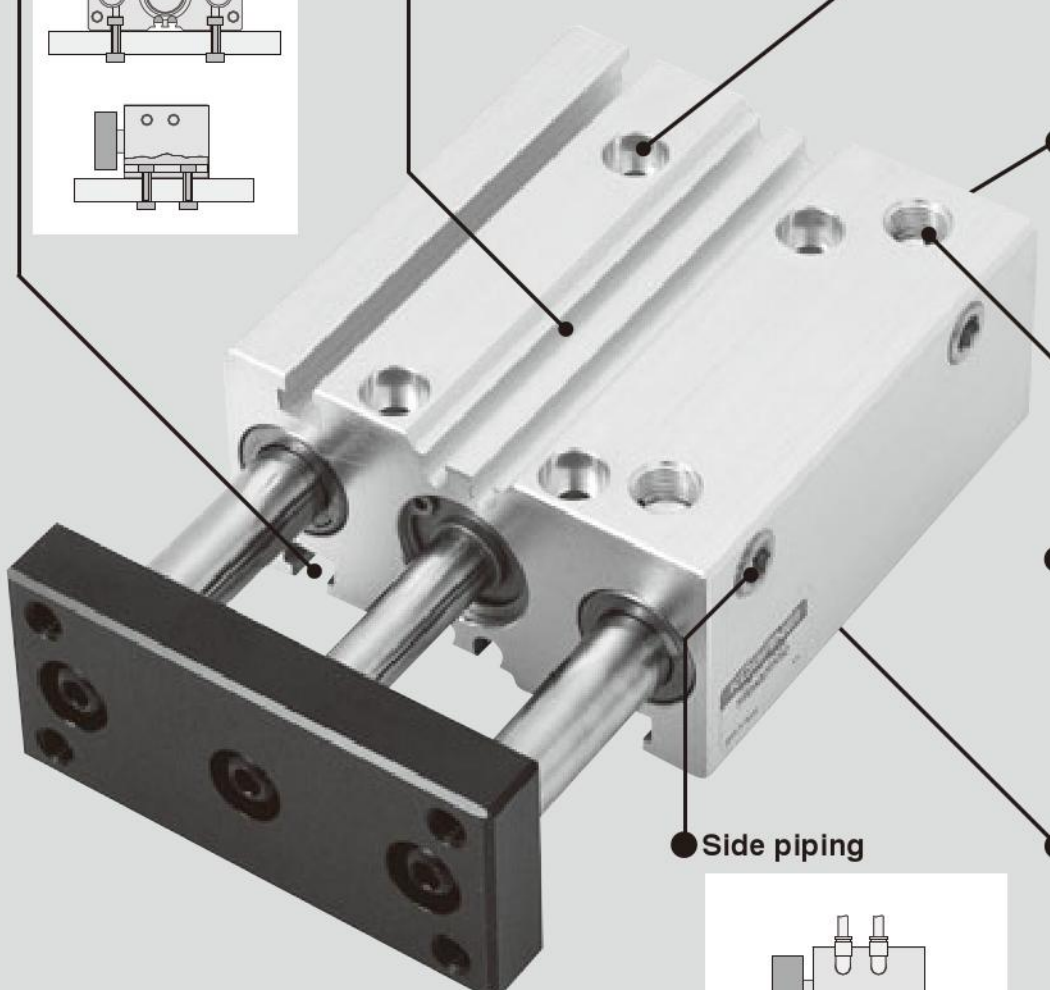
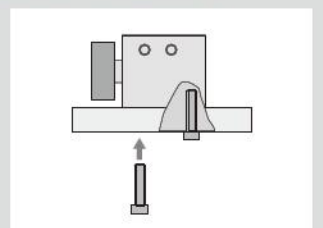

*Slim & Compact shape*  
**JIG CYLINDERS WITH GUIDES**  
 Optimum for conveyor line stoppers or lifters.  
 Moreover, end keep mechanism  
 for greater use!

# SQUARE FLEXIBLE POWERFUL

## ■ Standard Cylinders



## ■ Stroke Adjusting Cylinders



## ■ End Keep Cylinders



## ● Stroke Adjusting Cylinders



Adjusting rod can be used to adjust the range of the push-side stroke by 0~10mm [0~0.394in.].

## ● End Keep Cylinders



Flat shape prevents the keep portion from protruding from the side surface, to allow easy mounting in tight spaces.

## ■ Cylinders for Clean Systems



## ■ Sensor Switches

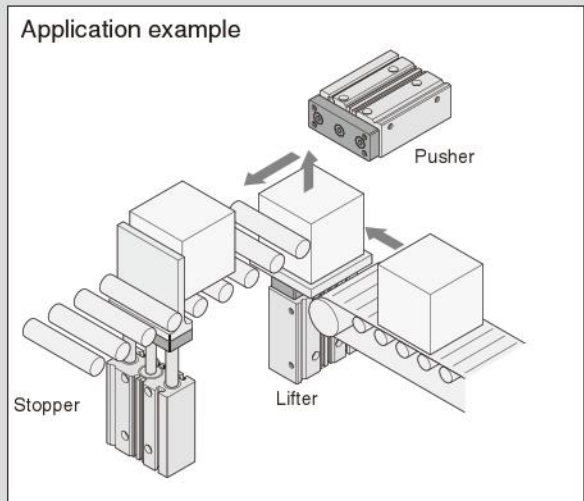
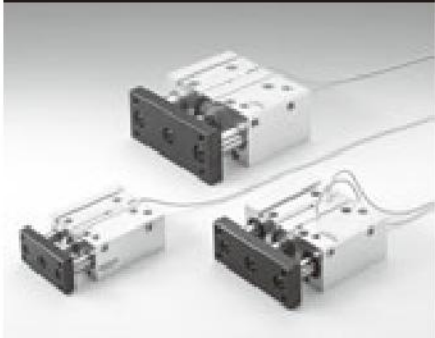

JIG CYLINDERS WITH GUIDES  $\phi 12 \sim \phi 63$

## Handling Instructions and Precautions

### Mounting

1. While any mounting direction is allowed, the mounting surface should always be flat. Twisting or bending during mounting may disturb the accuracy and may also result in air leaks or improper operation.
2. Care should be taken that scratches or dents on the cylinder's mounting surface may damage its flatness.
3. The hexagon socket head bolt on the rod end plate has been secured with adhesive. Always confirm that the rod end plate and hexagon socket head bolts are secured before using the cylinder.
4. In applications subject to large shocks, reinforcing the bolt mounting, by installing a support to the cylinder body for example, is recommended.
5. Ensure that the mounting bolts for the cylinder body and end plate are sufficiently strong.
6. Take preventive measures when shocks or vibrations might loosen the bolts.
7. Do not leave scratches or dents in the areas where the piston rod and the guide rod contact. It could result in damage to the seal or in air leaks.
8. The piston rod and guide rod are coated with grease. Do not wipe it off, as it may result in improper operation. Apply grease if no lubrication is visible.  
Grease: General type; Lithium grease No. 2

### Sensor switch

The magnet for sensor switches is built into the cylinder. Mounting sensor switch will enable use in sensor switch applications.

**Caution:** For the sensor switch mounting location and moving instructions, see p.734.

### Atmosphere

1. If using in locations subject to dripping water, dripping oil, etc., or to large amounts of dust, use a cover to protect the unit.
2. Do not use the cylinder in ambient atmospheres that could result in corrosion. Application in this kind of environment may result in damage or in improper operation.
3. Do not use in extremely dry conditions.
4. The most desirable temperature range for cylinders is 5~60°C [41~140°F]. Do not use in condition where temperatures exceed 60°C [140°F], as it could result in damage or in improper operation. In addition, since the moisture content at temperatures below 5°C [41°F] could freeze, resulting in damage or in improper operation, care should be taken to prevent freezing.

### General precautions

1. Always thoroughly blow off (use compressed air) the tubing before piping. Entering chips, sealing tape, rust, etc., generated during piping work could result in air leaks or other defective operation.
2. Air used for the cylinder should be clean air that contains no deteriorated compressor oil, etc. Install an air filter (filtration of a minimum 40 µm) near the cylinder or valve to remove collected liquid or dust. In addition, drain the air filter periodically. Collected liquid or dust entering the cylinder may cause improper operation.
3. The product can be used without lubrication, if lubrication is required, use Turbine Oil Class 1 (ISO VG32) or equivalent. Avoid using spindle oil or machine oil.

### When in use

1. Do not place hands, etc., in the cylinder's operating range.
2. Pay full attention to the cylinder operating direction during set up.
3. Care should be taken to avoid trapping body or fingers between the cylinder body and the end plate when the cylinder retracts.
4. Confirm that no residual pressure remains inside the cylinder before commencing maintenance.
5. In its application as a stopper, it is assumed that the carried objects will be cardboard boxes, plastic cases, etc. In cases where steel and other metal blocks are carried, select a sufficiently margined safer product or take measures to fully absorb the impacts.
6. Use the cylinder at speed of 500mm/s [19.7in./sec.] or less. But when the speed and loads are high even within the allowable ranges, install an external stopper, etc., to ensure that the cylinder is not exposed to direct shocks.
7. Do not use **SGDA□Q** (rolling bearing type) as a stopper.

# Handling Instructions and Precautions

## Control circuit for the end keep cylinder

1. For control of the Jig End Keep Cylinder with Guide, we recommend the use of 2-position, 4-, 5-port valves. Avoid the use of control circuit with ABR connection (exhaust center) 3-position valves that exhaust air from 2 delivery ports.
2. Always use meter-out control for speed control. Meter-in control may result in failure of the locking mechanism to release.

- Cautions:**
1. It is dangerous to supply air to a connection port on a side with a locking mechanism while the cylinder has already been exhausted, because the piston rod may suddenly extend (or retract). In addition, since the lock piston could also cause galling of the lock piston and piston rod, resulting in defective operation. Always supply air to the connection port on the opposite side of the locking mechanism to ensure applying back pressure.
  2. When restarting operations after air has been exhausted from the cylinder due to completion of operations or to an emergency stop, always start by supplying air to a connection port on the opposite side of the locking mechanism.
  3. Connect the valve port A (NC) to the connection port on the side with the locking mechanism.

## Manual operation of locking mechanism

While the locking mechanism is normally released automatically through cylinder operations, it can also be released manually. For manual release, insert an M3×0.5 ( $\phi$  12, 16 is M2.5×0.45) screw that has 30mm [1.18in.] screw length into the opening for manual override, thread it in about 3 turns into the internal lock piston, and then pull up the screw. To maintain the manual override for adjustment, etc., thread the locknut onto the screw and, with the locking mechanism in a released state, tighten the locknut against the cylinder.

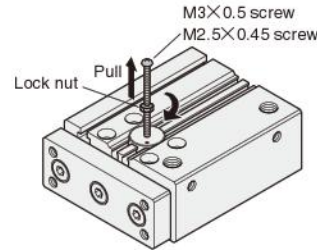

- Cautions:**
1. It is dangerous to release the lock when load (weight) is present on the piston rod, because it may cause the unintended piston rod's extension (or retraction). In this case, always supply air to the connection port opposite the one adjacent to the locking mechanism before releasing the locking mechanism.
  2. If the locking mechanism cannot easily be released even with manual override, it could be the result of galling of the lock piston and piston rod. In this case, supply air to the connection port opposite the one adjacent to the locking mechanism before releasing the locking mechanism.
  3. Water, oil, dust, etc., intruding through the opening for manual override may be a cause of defective locks or other erratic operation. If using in locations subject to dripping water, dripping oil, etc., or large amounts of dust, use a cover to protect the unit.

## Precautions for Mounting of Fittings

- In the installation shown in the diagram below, be aware of the fitting outer diameter.

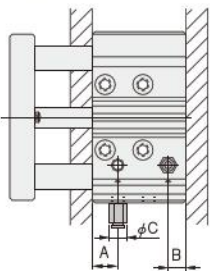

- ※ Positions A and B are dimensions of the port location closer to the end surface of the body.

- In products with a stroke of 10mm, be aware of the P dimension when using the side ports.

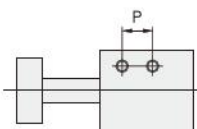

Bore size	Port size	Port location		Fitting outer diameter
		A	B	$\phi$ C
12 [0.472]	M5 ×	9 [0.354]	6 [0.236]	$\phi$ 11 [0.433] or less
16 [0.630]	0.8		7.5 [0.295]	$\phi$ 13 [0.512] or less
20 [0.787]	Rc1/8	11 [0.433]	10 [0.394]	$\phi$ 19 [0.748] or less
25 [0.984]			12 [0.472]	$\phi$ 19 [0.748] or less
32 [1.260]	Rc1/8	10 [0.394]	12 [0.472]	$\phi$ 19 [0.748] or less
40 [1.575]			14 [0.551]	$\phi$ 25 [0.984] or less
50 [1.969]	Rc1/4	10 [0.394]	15 [0.591]	$\phi$ 19 [0.748] or less
63 [2.480]			14 [0.551]	$\phi$ 19 [0.748] or less

Bore size	Port size	Between-ports dimension	Fitting outer diameter
		P	$\phi$ C
12 [0.472]	M5 ×	12 [0.472]	$\phi$ 11 [0.433] or less
16 [0.630]	0.8		$\phi$ 11 [0.433] or less
20 [0.787]	Rc1/8	15 [0.591]	$\phi$ 14 [0.551] or less
25 [0.984]			$\phi$ 14 [0.551] or less
32 [1.260]	Rc1/8	15 [0.591]	$\phi$ 14 [0.551] or less
40 [1.575]			$\phi$ 14 [0.551] or less
50 [1.969]	Rc1/4	16 [0.630]	$\phi$ 15 [0.591] or less
63 [2.480]			$\phi$ 15 [0.591] or less

Caution: Apply sealants when re-using a block-off plug. Avoid getting sealant into the cylinder.

## Precautions When Bottom Mounting

- Drill the guide rod escape hole when the stroke is 75mm or longer (except for SGDA□ 12).
- When using as a stopper, etc., subject to shocks, the mounting screw's mating thread length should be as close to 2d as possible.

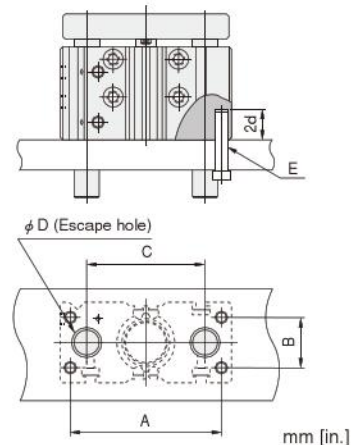

Bore size	A	B	C	$\phi$ D		Bolt E for mounting
				SGDA□ Slide bearing	SGDA□Q Rolling bearing	
12 [0.472]	51 [2.008]	18 [0.709]	42 [1.654]	10 [0.394]	8 [0.315]	M4 × 0.7
16 [0.630]	60 [2.362]	20 [0.787]	47 [1.850]	12 [0.472]	10 [0.394]	M5 × 0.8
20 [0.787]	72 [2.835]	26 [1.024]	58 [2.283]	16 [0.630]	14 [0.551]	M6 × 1
25 [0.984]	80 [3.150]	30 [1.181]	63 [2.480]	18 [0.709]	16 [0.630]	M6 × 1
32 [1.260]	100 [3.937]	34 [1.339]	80 [3.150]	22 [0.866]	18 [0.709]	M8 × 1.25
40 [1.575]	106 [4.173]	40 [1.575]	90 [3.543]	22 [0.866]	18 [0.709]	M8 × 1.25
50 [1.969]	130 [5.118]	44 [1.732]	110 [4.331]	27 [1.063]	22 [0.866]	M10 × 1.5
63 [2.480]	144 [5.669]	44 [1.732]	122 [4.803]	27 [1.063]	22 [0.866]	M10 × 1.5

# Cylinder Thrust

Select a suitable cylinder bore size considering the load and air pressure to obtain the required thrust. Since the figures in the table are calculated values, select a bore size that results in a load ratio (load ratio =  $\frac{\text{Load}}{\text{Calculated value}}$ ) of 70% or less (50% or less for high speed application).



Bore size mm [in.]	Piston rod diameter mm [in.]	Operation	Pressure area mm <sup>2</sup> [in. <sup>2</sup> ]	Air pressure MPa [psi.]									
				0.1 [15]	0.2 [29]	0.3 [44]	0.4 [58]	0.5 [73]	0.6 [87]	0.7 [102]	0.8 [116]	0.9 [131]	1.0 [145]
12 [0.472]	6 [0.236]	Push side	113.0 [0.1752]	11.3 [2.54]	22.6 [5.08]	33.9 [7.62]	45.2 [10.2]	56.5 [12.7]	67.8 [15.2]	79.1 [17.8]	90.4 [20.3]	101.7 [22.86]	113.0 [25.40]
		Pull side	84.8 [0.1314]	8.5 [1.91]	17.0 [3.82]	25.4 [5.71]	33.9 [7.62]	42.4 [9.53]	50.9 [11.4]	59.3 [13.3]	67.8 [15.2]	76.3 [17.15]	84.8 [19.06]
		Stroke adjustment	84.8 [0.1314]	8.5 [1.91]	17.0 [3.82]	25.4 [5.71]	33.9 [7.62]	42.4 [9.53]	50.9 [11.4]	59.3 [13.3]	67.8 [15.2]	76.3 [17.15]	84.8 [19.06]
16 [0.630]	8 [0.315]	Push side	201.0 [0.3116]	20.1 [4.52]	40.2 [9.04]	60.3 [13.6]	80.4 [18.1]	100.5 [22.59]	120.6 [27.11]	140.7 [31.63]	160.8 [36.15]	180.9 [40.67]	201.0 [45.18]
		Pull side	150.7 [0.2336]	15.1 [3.39]	30.1 [6.77]	45.2 [10.2]	60.3 [13.6]	75.4 [16.95]	90.4 [20.32]	105.5 [23.72]	120.6 [27.11]	135.6 [30.48]	150.7 [33.88]
		Stroke adjustment	150.7 [0.2336]	15.1 [3.39]	30.1 [6.77]	45.2 [10.2]	60.3 [13.6]	75.4 [16.95]	90.4 [20.32]	105.5 [23.72]	120.6 [27.11]	135.6 [30.48]	150.7 [33.88]
20 [0.787]	10 [0.394]	Push side	314.0 [0.4867]	31.4 [7.06]	62.8 [14.1]	94.2 [21.2]	125.6 [28.23]	157.0 [35.29]	188.4 [42.35]	219.8 [49.41]	251.2 [56.47]	282.6 [63.53]	314.0 [70.59]
		Pull side	235.5 [0.3650]	23.6 [5.31]	47.1 [10.6]	70.7 [15.9]	94.2 [21.18]	117.8 [26.48]	141.3 [31.76]	164.9 [37.07]	188.4 [42.35]	212.0 [47.66]	235.5 [52.94]
		Stroke adjustment	235.5 [0.3650]	23.6 [5.31]	47.1 [10.6]	70.7 [15.9]	94.2 [21.18]	117.8 [26.48]	141.3 [31.76]	164.9 [37.07]	188.4 [42.35]	212.0 [47.66]	235.5 [52.94]
25 [0.984]	12 [0.472]	Push side	490.6 [0.7604]	49.1 [11.0]	98.1 [22.1]	147.2 [33.09]	196.3 [44.13]	245.3 [55.14]	294.4 [66.18]	343.4 [77.20]	392.5 [88.24]	441.6 [99.27]	490.6 [110.3]
		Pull side	377.6 [0.5853]	37.8 [8.50]	75.5 [17.0]	113.3 [25.47]	151.0 [33.94]	188.8 [42.44]	226.6 [50.94]	264.3 [59.41]	302.1 [67.91]	339.8 [76.39]	377.6 [84.89]
		Stroke adjustment	377.6 [0.5853]	37.8 [8.50]	75.5 [17.0]	113.3 [25.47]	151.0 [33.94]	188.8 [42.44]	226.6 [50.94]	264.3 [59.41]	302.1 [67.91]	339.8 [76.39]	377.6 [84.89]
32 [1.260]	16 [0.630]	Push side	803.8 [1.2459]	80.4 [18.1]	160.8 [36.15]	241.2 [54.22]	321.5 [72.27]	401.9 [90.35]	482.3 [108.4]	562.7 [126.5]	643.1 [144.6]	723.5 [162.6]	803.8 [180.7]
		Pull side	602.9 [0.9345]	60.3 [13.6]	120.6 [27.11]	180.9 [40.67]	241.2 [54.22]	301.4 [67.75]	361.7 [81.31]	422.0 [94.87]	482.3 [108.4]	542.6 [122.0]	602.9 [135.5]
		Stroke adjustment	602.9 [0.9345]	60.3 [13.6]	120.6 [27.11]	180.9 [40.67]	241.2 [54.22]	301.4 [67.75]	361.7 [81.31]	422.0 [94.87]	482.3 [108.4]	542.6 [122.0]	602.9 [135.5]
40 [1.575]	16 [0.630]	Push side	1256.0 [1.9468]	125.6 [28.23]	251.2 [56.47]	376.8 [84.70]	502.4 [112.9]	628.0 [141.2]	753.6 [169.4]	879.2 [197.6]	1004.8 [225.9]	1130.4 [254.1]	1256.0 [282.3]
		Pull side	1055.0 [1.6353]	105.5 [23.72]	211.0 [47.43]	316.5 [71.15]	422.0 [94.87]	527.0 [118.5]	633.0 [142.3]	738.5 [166.0]	844.0 [189.7]	949.5 [213.4]	1055.0 [237.2]
		Stroke adjustment	1055.0 [1.6353]	105.5 [23.72]	211.0 [47.43]	316.5 [71.15]	422.0 [94.87]	527.0 [118.5]	633.0 [142.3]	738.5 [166.0]	844.0 [189.7]	949.5 [213.4]	1055.0 [237.2]
50 [1.969]	20 [0.787]	Push side	1962.5 [3.0419]	196.3 [44.13]	392.5 [88.23]	588.8 [132.4]	785.0 [176.5]	981.3 [220.6]	1177.5 [264.7]	1373.8 [308.8]	1570.0 [352.9]	1766.3 [397.1]	1962.5 [441.2]
		Pull side	1648.5 [2.5552]	164.9 [37.07]	329.7 [74.12]	494.6 [111.2]	659.4 [148.2]	824.3 [185.3]	989.1 [222.3]	1154.0 [259.4]	1318.8 [296.5]	1483.7 [333.5]	1648.5 [370.6]
		Stroke adjustment	1648.5 [2.5552]	164.9 [37.07]	329.7 [74.12]	494.6 [111.2]	659.4 [148.2]	824.3 [185.3]	989.1 [222.3]	1154.0 [259.4]	1318.8 [296.5]	1483.7 [333.5]	1648.5 [370.6]
63 [2.480]	20 [0.787]	Push side	3115.7 [4.8293]	311.6 [70.05]	623.1 [140.1]	934.7 [210.1]	1246.3 [280.2]	1557.8 [350.2]	1869.4 [420.2]	2181.0 [490.3]	2492.5 [560.3]	2804.1 [630.4]	3115.7 [700.4]
		Pull side	2801.7 [4.3426]	280.2 [62.99]	560.3 [126.0]	840.5 [188.9]	1120.7 [251.9]	1400.8 [314.9]	1681.0 [377.9]	1961.2 [440.9]	2241.3 [503.9]	2521.5 [566.9]	2801.7 [629.9]
		Stroke adjustment	2801.7 [4.3426]	280.2 [62.99]	560.3 [126.0]	840.5 [188.9]	1120.7 [251.9]	1400.8 [314.9]	1681.0 [377.9]	1961.2 [440.9]	2241.3 [503.9]	2521.5 [566.9]	2801.7 [629.9]

# Allowable Lateral Load

Lateral load (F) on the rod end should be at or below the figures in the table below.

Bore mm [in.]	Stroke mm	Type	N [lbf.]										
			10	20	30	40	50	75	100	125	150	175	200
12 [0.472]	12	Slide bearing type	29 [6.5]	23 [5.2]	19 [4.3]	16.5 [3.7]	15 [3.4]	27.5 [6.2]	23 [5.2]	—	—	—	—
		Rolling bearing type	26 [5.8]	20 [4.5]	17 [3.8]	14.5 [3.3]	13 [2.9]	24 [5.4]	20 [4.5]	—	—	—	—
16 [0.630]	16	Slide bearing type	37 [8.3]	30.5 [6.9]	26 [5.8]	22.5 [5.1]	20 [4.5]	35 [7.9]	30 [6.7]	—	—	—	—
		Rolling bearing type	40 [9.0]	32 [7.2]	27 [6.1]	24 [5.4]	19 [4.3]	34 [7.6]	28 [6.3]	—	—	—	—
20 [0.787]	20	Slide bearing type	69 [15.5]	58 [13.0]	50 [11.2]	44 [9.9]	40 [9.0]	91 [20.5]	78 [17.5]	68 [15.3]	60 [13.5]	54 [12.1]	49 [11.0]
		Rolling bearing type	58 [13.0]	49 [11.0]	38 [8.5]	36 [8.1]	33 [7.4]	77 [17.3]	66 [14.8]	58 [13.0]	51 [11.5]	46 [10.3]	42 [9.4]
25 [0.984]	25	Slide bearing type	95 [21.4]	80.5 [18.1]	70 [15.7]	61 [13.7]	55 [12.4]	116 [26.1]	100 [22.5]	87 [19.6]	77 [17.3]	70 [15.7]	63 [14.2]
		Rolling bearing type	58 [13.0]	49 [11.0]	38 [8.5]	37 [8.3]	33 [7.4]	77 [17.3]	66 [14.8]	58 [13.0]	51 [11.5]	46 [10.3]	42 [9.4]
32 [1.260]	32	Slide bearing type	273 [61.4]	237 [53.3]	209 [47.0]	188 [42.3]	170 [38.2]	195 [43.8]	160 [36.0]	150 [33.7]	134 [30.1]	122 [27.4]	111 [25.0]
		Rolling bearing type	113 [25.4]	98 [22.0]	86 [19.3]	77 [17.3]	70 [15.7]	150 [33.7]	130 [29.2]	115 [25.9]	103 [23.2]	94 [21.1]	86 [19.3]
40 [1.575]	40	Slide bearing type	273 [61.4]	237 [53.3]	209 [47.0]	188 [42.3]	170 [38.2]	195 [43.8]	160 [36.0]	150 [33.7]	134 [30.1]	122 [27.4]	111 [25.0]
		Rolling bearing type	113 [25.4]	98 [22.0]	86 [19.3]	77 [17.3]	70 [15.7]	150 [33.7]	130 [29.2]	115 [25.9]	103 [23.2]	94 [21.1]	86 [19.3]
50 [1.969]	50	Slide bearing type	398 [89.5]	351 [78.9]	314 [70.6]	284 [63.8]	260 [58.4]	272 [61.1]	240 [54.0]	213 [47.9]	193 [43.4]	176 [39.6]	161 [36.2]
		Rolling bearing type	135 [30.3]	119 [26.8]	106.5 [23.9]	96 [21.6]	88 [19.8]	170 [38.2]	150 [33.7]	134 [30.1]	121 [27.2]	110 [24.7]	100 [22.5]
63 [2.480]	63	Slide bearing type	398 [89.5]	351 [78.9]	314 [70.6]	284 [63.8]	260 [58.4]	272 [61.1]	240 [54.0]	213 [47.9]	193 [43.4]	176 [39.6]	161 [36.2]
		Rolling bearing type	135 [30.3]	119 [26.8]	106.5 [23.9]	96 [21.6]	88 [19.8]	170 [38.2]	150 [33.7]	134 [30.1]	121 [27.2]	110 [24.7]	100 [22.5]

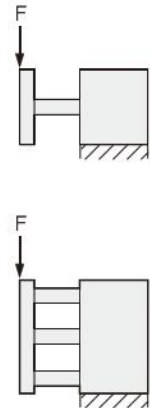

# End Plate Non-rotation Accuracy θ

Bore size mm [in.]	SGDA	SGDAQ	SGDAKQ, CS-SGDAQ
12 [0.472]	±0.1°	±0.06°	±0.06°
16 [0.630]	±0.09°	±0.06°	±0.06°
20 [0.787]	±0.08°	±0.07°	±0.05°
25 [0.984]	±0.07°	±0.07°	±0.05°
32 [1.260]	±0.06°	±0.03°	±0.03°
40 [1.575]	±0.06°	±0.03°	±0.03°
50 [1.969]	±0.05°	±0.03°	±0.03°
63 [2.480]	±0.05°	±0.03°	±0.03°

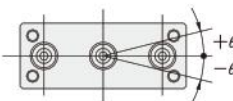

Note: When cylinder is retracted (initial value). Guide rod deflection excluded.

# Allowable Twisting Torque for the End Plate

N · m [ft · lbf]

Bore mm [in.]	Stroke mm Type	10	20	30	40	50	75	100	125	150	175	200
		<b>12</b> [0.472]	Slide bearing type	0.30 [0.221]	0.24 [0.178]	0.20 [0.148]	0.17 [0.125]	0.16 [0.118]	0.29 [0.214]	0.24 [0.177]	—	—
	Rolling bearing type	0.27 [0.199]	0.21 [0.155]	0.18 [0.133]	0.15 [0.111]	0.14 [0.103]	0.25 [0.184]	0.21 [0.155]	—	—	—	—
<b>16</b> [0.630]	Slide bearing type	0.43 [0.317]	0.36 [0.266]	0.31 [0.229]	0.26 [0.192]	0.24 [0.177]	0.41 [0.302]	0.35 [0.258]	—	—	—	—
	Rolling bearing type	0.47 [0.347]	0.38 [0.280]	0.32 [0.236]	0.28 [0.207]	0.22 [0.162]	0.40 [0.295]	0.33 [0.243]	—	—	—	—
<b>20</b> [0.787]	Slide bearing type	1.00 [0.738]	0.84 [0.620]	0.73 [0.538]	0.64 [0.472]	0.58 [0.428]	1.32 [0.974]	1.13 [0.833]	0.99 [0.730]	0.87 [0.642]	0.78 [0.575]	0.71 [0.524]
	Rolling bearing type	0.84 [0.620]	0.71 [0.524]	0.55 [0.406]	0.52 [0.384]	0.48 [0.354]	1.12 [0.826]	0.96 [0.708]	0.84 [0.620]	0.74 [0.546]	0.67 [0.494]	0.61 [0.450]
<b>25</b> [0.984]	Slide bearing type	1.50 [1.106]	1.27 [0.937]	1.10 [0.811]	0.96 [0.708]	0.87 [0.642]	1.83 [1.350]	1.58 [1.165]	1.37 [1.011]	1.21 [0.892]	1.10 [0.811]	0.99 [0.730]
	Rolling bearing type	0.91 [0.671]	0.77 [0.568]	0.60 [0.443]	0.58 [0.428]	0.52 [0.384]	1.21 [0.892]	1.04 [0.767]	0.91 [0.671]	0.80 [0.590]	0.72 [0.531]	0.66 [0.487]
<b>32</b> [1.260]	Slide bearing type	5.46 [4.027]	4.74 [3.496]	4.18 [3.083]	3.76 [2.773]	3.40 [2.508]	3.90 [2.877]	3.20 [2.360]	3.00 [2.213]	2.68 [1.978]	2.44 [1.800]	2.22 [1.637]
	Rolling bearing type	2.26 [1.667]	1.96 [1.446]	1.72 [1.269]	1.54 [1.136]	1.40 [1.033]	3.00 [2.213]	2.60 [1.918]	2.30 [1.696]	2.06 [1.519]	1.88 [1.387]	1.72 [1.269]
<b>40</b> [1.575]	Slide bearing type	6.14 [4.529]	5.33 [3.931]	4.70 [3.467]	4.23 [3.120]	3.83 [2.825]	4.39 [3.238]	3.60 [2.655]	3.38 [2.493]	3.02 [2.228]	2.75 [2.028]	2.50 [1.844]
	Rolling bearing type	2.54 [1.874]	2.21 [1.630]	1.94 [1.431]	1.73 [1.276]	1.58 [1.165]	3.38 [2.493]	2.93 [2.161]	2.59 [1.910]	2.32 [1.711]	2.12 [1.564]	1.94 [1.431]
<b>50</b> [1.969]	Slide bearing type	10.95 [8.077]	9.65 [7.118]	8.64 [6.373]	7.81 [5.761]	7.15 [5.274]	7.48 [5.517]	6.60 [4.868]	5.86 [4.322]	5.31 [3.917]	4.84 [3.570]	4.43 [3.268]
	Rolling bearing type	3.71 [2.736]	3.27 [2.412]	2.93 [2.161]	2.64 [1.947]	2.42 [1.785]	4.68 [3.452]	4.13 [3.046]	3.69 [2.722]	3.33 [2.456]	3.03 [2.235]	2.75 [2.028]
<b>63</b> [2.480]	Slide bearing type	12.05 [8.888]	10.71 [7.900]	9.58 [7.066]	8.66 [6.388]	7.93 [5.849]	8.30 [6.122]	7.32 [5.399]	6.50 [4.794]	5.89 [4.344]	5.37 [3.961]	4.91 [3.622]
	Rolling bearing type	4.12 [3.039]	3.63 [2.677]	3.25 [2.397]	2.93 [2.161]	2.68 [1.977]	5.19 [3.828]	4.58 [3.378]	4.09 [3.017]	3.69 [2.722]	3.36 [2.478]	3.05 [2.250]

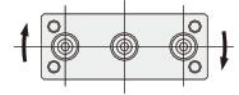

## Allowable Range When Used as a Stopper

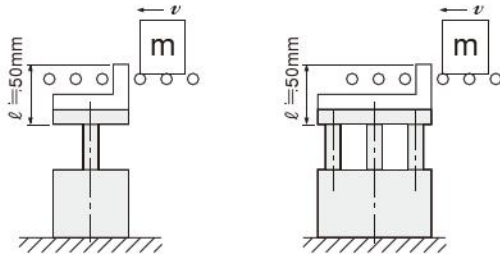

※ For product selection when the  $l$  dimension is longer, select one with a sufficient cylinder bore.

### Precautions for handling

- Notes: 1. When using as a stopper, select product with a stroke of 50mm or less.  
 2. The rolling bearing type cannot be used as a stopper.  
 3. When the stopper becomes subject to friction force generated by friction between the carried object and the conveyor, etc., keep the friction force at the allowable lateral load or below.

## Allowable Load Range

Use the graph values below for the relation between the load and piston speed. When these values are exceeded, install an external stopper.

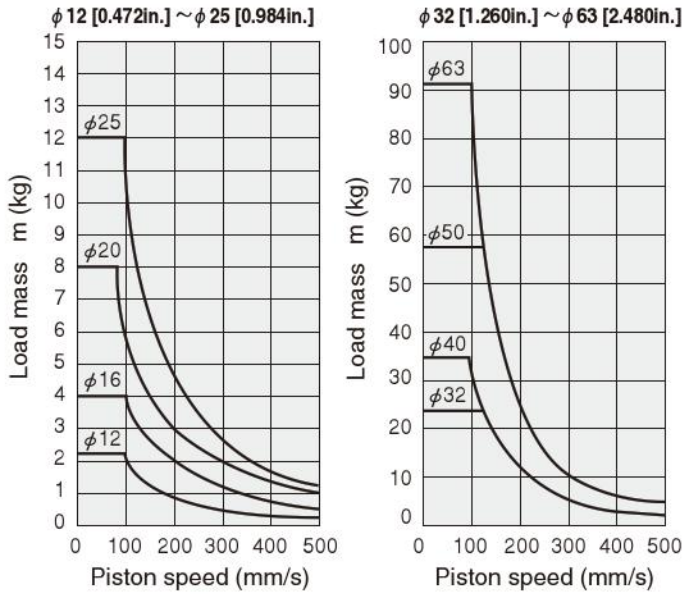

1kg = 2.205lb. 1mm/s = 0.0394in./sec.

φ12 [0.472in.] ~ φ20 [0.787in.]  
(Slide bearing)

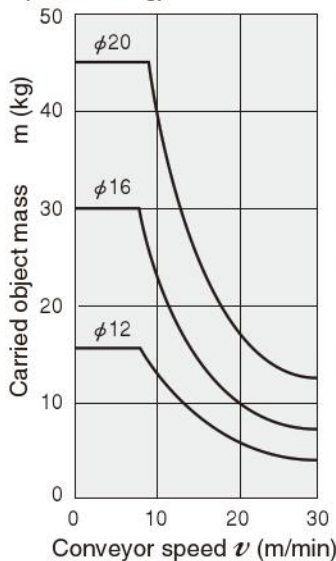

φ25 [0.984in.] ~ φ63 [2.480in.]  
(Slide bearing)

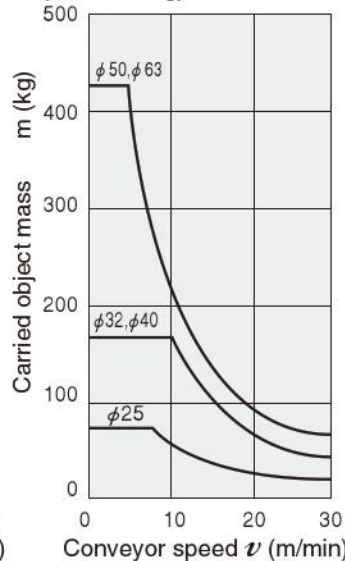

- Notes: 1. Figures assume that the carried objects are plastic containers.  
 2. Figures for φ12 ~ φ25 are st = 30, and for φ32 ~ φ63 are st = 50.

1kg = 2.205lb. 1m/min. = 3.281ft./min.

# Allowable Range When Used as a Lifter

● Select a cylinder bore so that the total mass of the load is the theoretical output (in the graphs below) or less.

Bore size mm [in.]	Theoretical output
φ 12 [0.472], φ 16 [0.630]	40% or less
φ 20 [0.787], φ 25 [0.984]	50% or less
φ 32 [1.260]~φ 63 [2.480]	60% or less

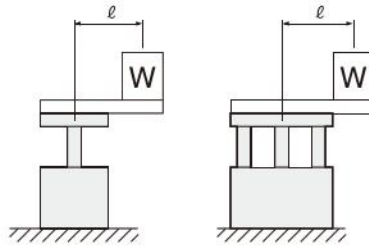

## ■ Slide bearing type (Applied pressure P = 0.5MPa [73psi.])

● φ 12 [0.472in.]  
~ φ 25 [0.984in.]  
(50mm or shorter strokes)

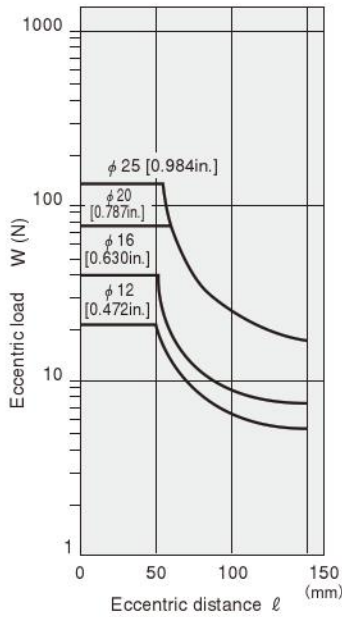

(75mm or longer strokes)

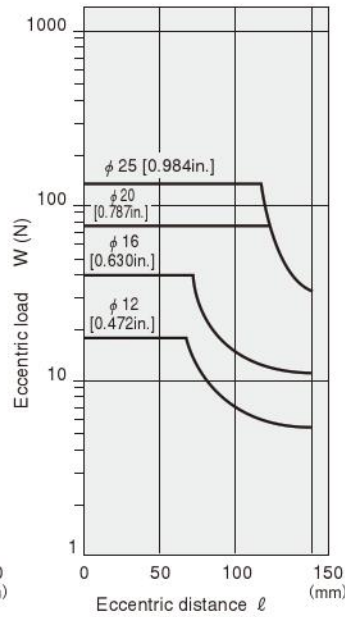

● φ 32 [1.260in.]  
~ φ 63 [2.480in.]  
(50mm or shorter strokes)

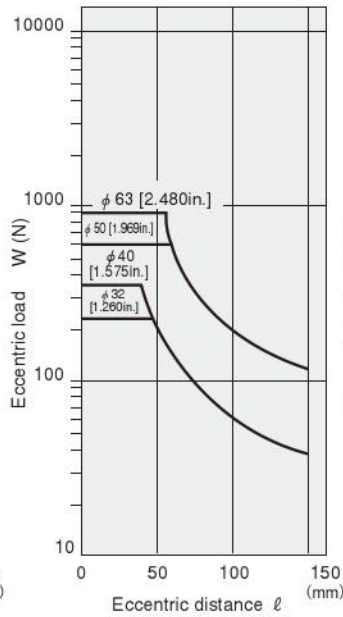

(75mm or longer strokes)

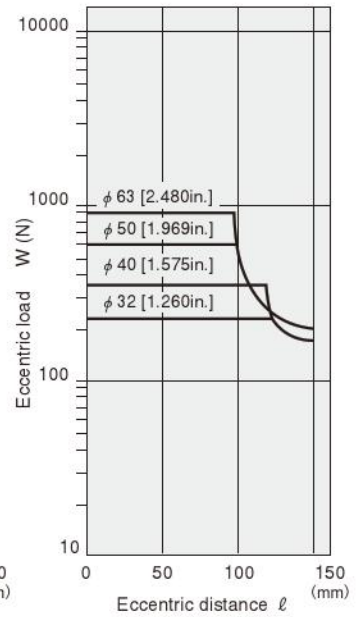

1N = 0.2248lbf.  
1mm = 0.0394in.

## ■ Rolling bearing type (applied pressure P = 0.5MPa [73psi.])

● φ 12 [0.472in.]  
~ φ 25 [0.984in.]  
(50mm or shorter strokes)

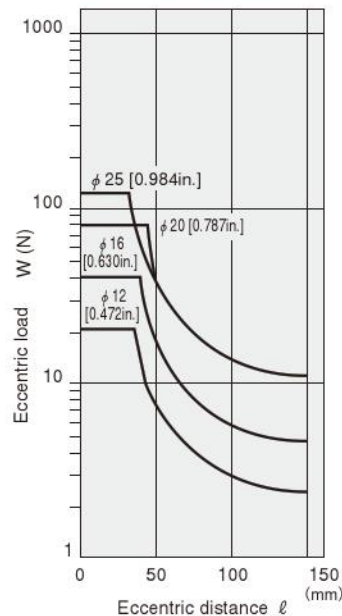

(75mm or longer strokes)

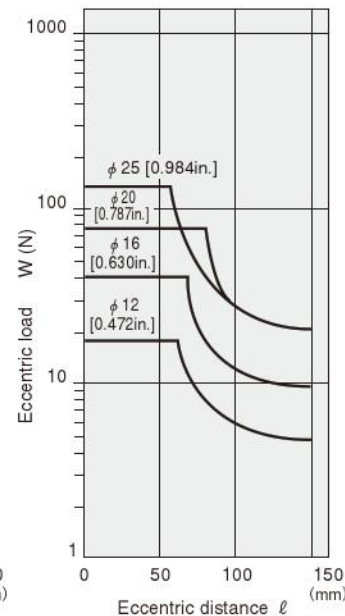

● φ 32 [1.260in.]  
~ φ 63 [2.480in.]  
(50mm or shorter strokes)

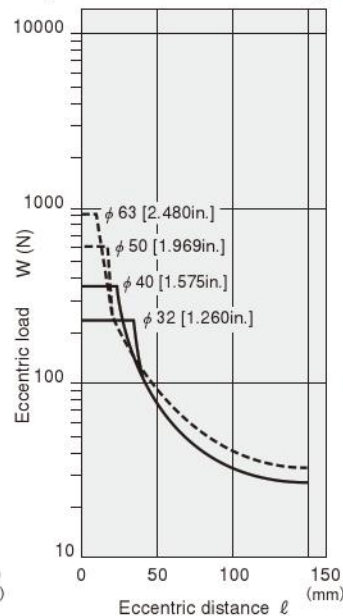

(75mm or longer strokes)

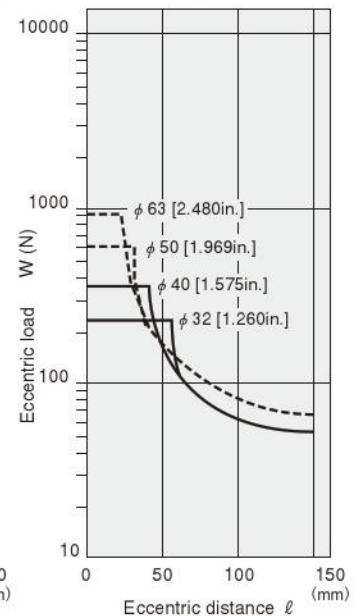

1N = 0.2248lbf.  
1mm = 0.0394in.

# JIG CYLINDERS WITH GUIDES

Stroke Adjusting Cylinders  $\phi 12 \sim \phi 63$

## Symbol

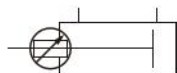

## Specifications

Item	Bore size mm [in.]	12 [0.472]	16 [0.630]	20 [0.787]	25 [0.984]	32 [1.260]	40 [1.575]	50 [1.969]	63 [2.480]
Operation type		Double acting type							
Media		Air							
Operating pressure range	MPa [psi.]	0.15 ~ 1.0 [22 ~ 145]				0.1 ~ 1.0 [15 ~ 145]			
Proof pressure	MPa [psi.]	1.5 [218]							
Operating temperature range	°C [°F]	0 ~ 60 [32 ~ 140]							
Operating speed range	mm/s [in./sec.]	100 ~ 500 [3.9 ~ 19.7]							
Cushion		Rubber bumper							
Lubrication		Not required (If lubrication is required, use Turbine Oil Class 1 [ISO VG32] or equivalent.)							
Port size		M5 X 0.8			Rc1/8			Rc1/4	
Push side stroke adjusting range	mm [in.]	0 ~ 10 [0 ~ 0.394] (With respect to the specification stroke)							

## Bore Size and Stroke

Bore size	Standard strokes	Maximum available stroke
12	10, 20, 30, 40, 50, 75, 100	100
16		
20	10, 20, 30, 40, 50, 75, 100, 125, 150, 175, 200	200
25		
32		
40		
50		
63		

Remark: For strokes of 75mm or longer, use long bushing type.

JIG CYLINDERS WITH GUIDES  $\phi 12 \sim \phi 63$

# Order Codes for Stroke Adjusting Cylinder

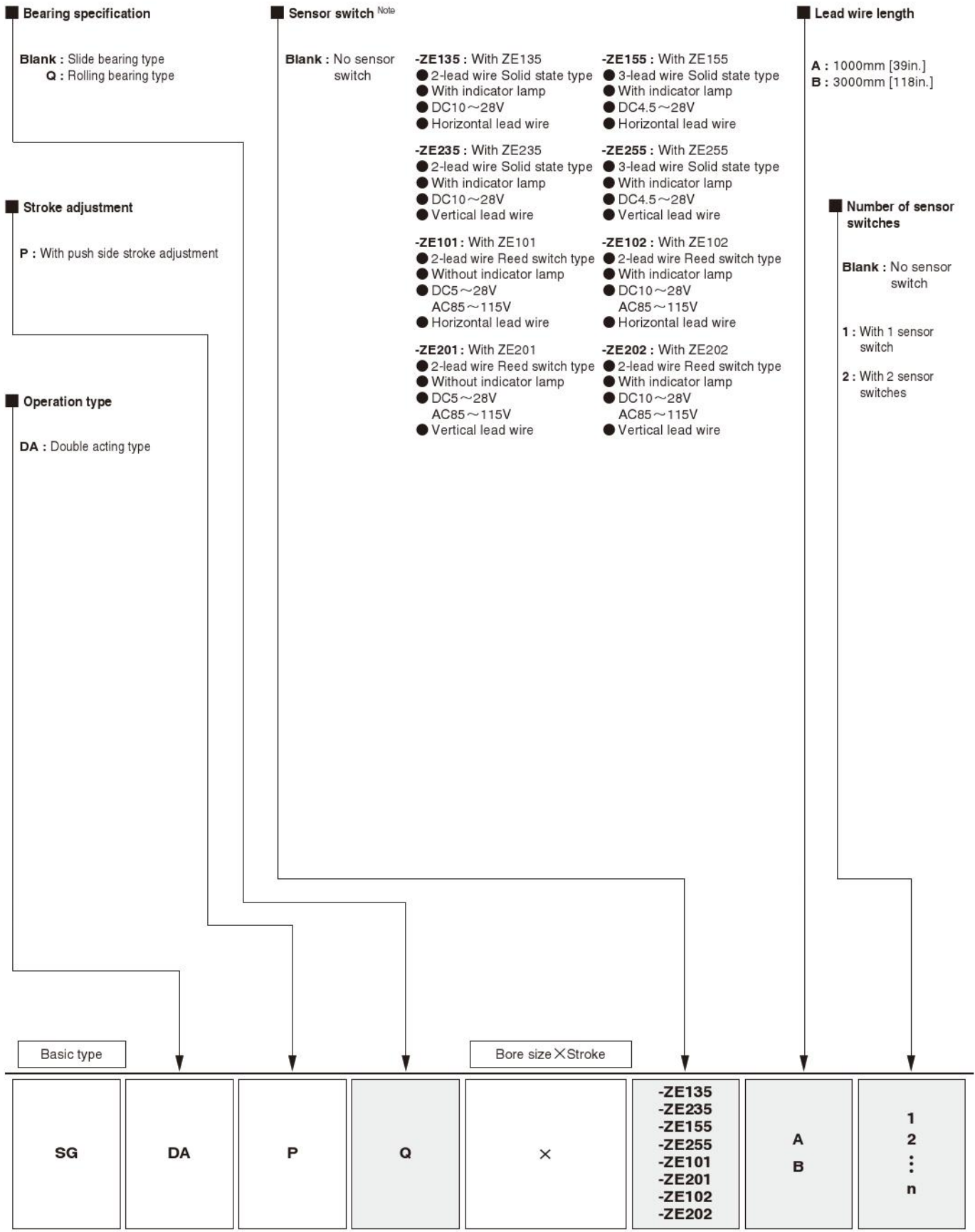

● See the bore size and stroke table on p.714. \_\_\_\_\_  
 ● For the order codes of sensor switches only, see p.733. \_\_\_\_\_

Note: For details of sensor switches, see p.733.

# Inner Construction and Major Parts

## Stroke adjusting cylinder

●  $\phi 12$

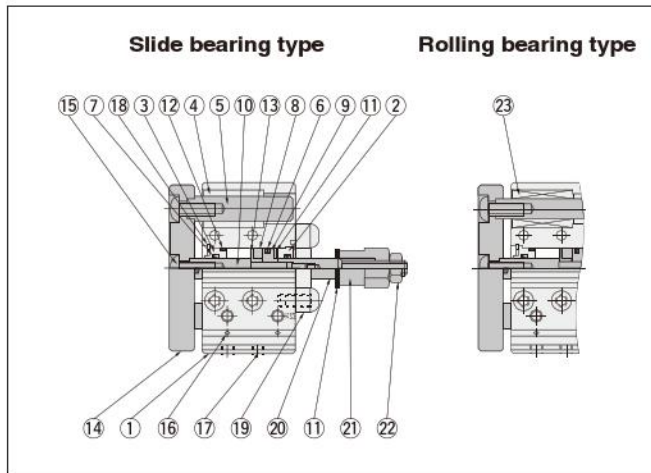

●  $\phi 16, \phi 20, \phi 25$  \*

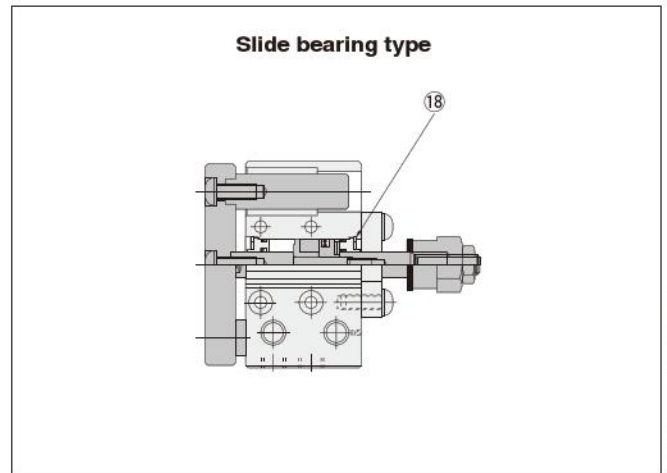

●  $\phi 32, \phi 40$  \*

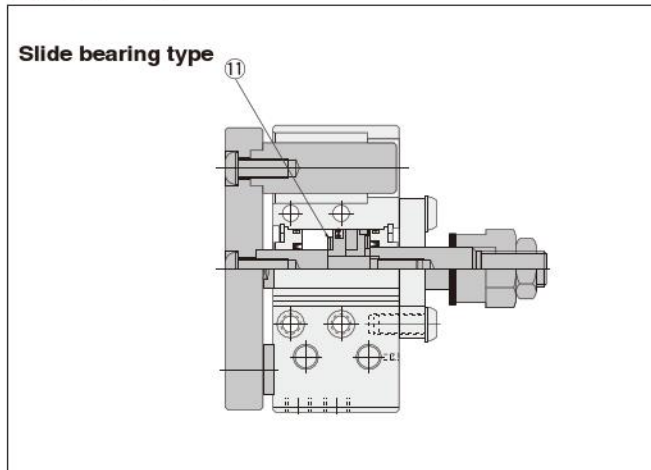

●  $\phi 50, \phi 63$  \*

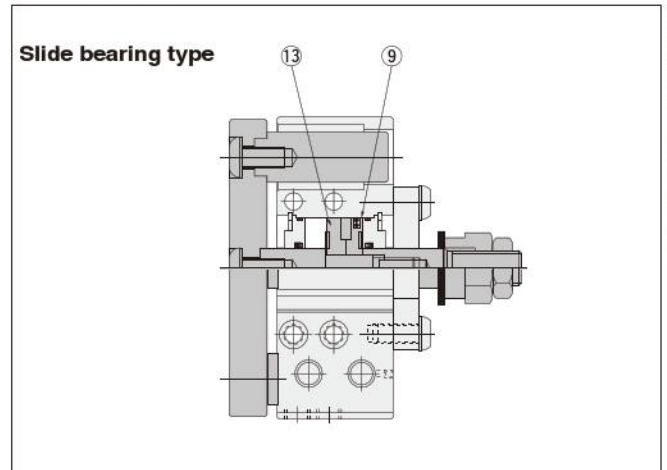

\* Same structure for the  $\phi 16 \sim \phi 63$  rolling bearing type and scraper specification  
 Remark: The number of bearings for 50mm stroke or shorter is 1 bearing per shaft. At 75mm stroke or longer, 2 bearings per shaft. The plate, piston rod, and guide rod cannot be disassembled.

## Major Parts and Materials

No.	Parts	Bore mm [in.]	12 [0.472]	16 [0.630]	20 [0.787]	25 [0.984]	32 [1.260]	40 [1.575]	50 [1.969]	63 [2.480]
①	Cylinder body		Aluminum alloy (anodized)							
②	Head cover		Aluminum alloy (special wear-resistant treatment)							
③	Rod cover		Aluminum alloy (special wear-resistant treatment)							
④	Slide bearing		Aluminum alloy (special wear-resistant treatment)							
⑤	Guide rod		Steel (hard chrome plated) (rolling bearing type: Steel)							
⑥	Piston seal		Synthetic rubber (NBR)							
⑦	Rod seal		Synthetic rubber (NBR)							
⑧	Magnet		Plastic magnet							
⑨	Piston		Aluminum alloy (special rust prevention treatment)							
⑩	Piston rod		Stainless steel (hard chrome plated)				Steel (hard chrome plated)			
⑪	Bumper		Synthetic rubber (NBR)							
⑫	O-ring		Synthetic rubber (NBR)							
⑬	Support		Aluminum alloy (special rust prevention treatment)							
⑭	Plate		Aluminum alloy (black anodized)							
⑮	Bolt		Steel (nickel plated)							
⑯	Steel ball		Steel							
⑰	Plug		Mild steel (zinc plated)							
⑱	Snap ring		Steel (phosphate coating)							
⑲	Stopper		Aluminum alloy (black anodized)							
⑳	Adjusting rod		Stainless steel (hard chrome plated)				Steel (hard chrome plated)			
㉑	Adjusting nut		Mild steel (zinc plated)							
㉒	Hexagon nut		Mild steel (zinc plated)							
㉓	Rolling bearing		Steel, plastic							

JIG CYLINDERS WITH GUIDES  $\phi 12 \sim \phi 63$

## Seals

Bore size mm	Type	Stroke adjusting cylinder			
	Parts	Rod seal	Piston seal	Tube gasket	
				Rod side	Head side
12		MYR-6	COP-12	Y090260	None
16		MYR-8	COP-16	Y090207	Y090207
20		MYR-10	COP-20	Y090216	Y090216
25		MYR-12	COP-25	Y090210	Y090210
32		MYR-16	COP-32	L090084	L090084
40		MYR-16	COP-40	L090151	L090151
50		MYR-20	COP-50	L090174	L090174
63		MYR-20	COP-63	L090180	L090180

## Mass

Bore size mm [in.]	Type	Stroke adjusting cylinder				Option	
	Mass	Slide bearing type		Rolling bearing type		Additional mass of sensor switch	
		Zero stroke mass	Additional mass for each 1mm [0.0394in.] stroke	Zero stroke mass	Additional mass for each 1mm [0.0394in.] stroke	ZE□□□□A	ZE□□□□B
12 [0.472]	50st or shorter	178 [6.28]	4.18 [0.1474]	168 [5.93]	3.82 [0.1347]	15 [0.53]	35 [1.23]
	75st or longer	188 [6.63]	4.18 [0.1474]	178 [6.28]	3.82 [0.1347]		
16 [0.630]	50st or shorter	323 [11.39]	5.54 [0.1954]	284 [10.02]	5.52 [0.1947]		
	75st or longer	369 [13.02]	5.54 [0.1954]	341 [12.03]	5.52 [0.1947]		
20 [0.787]	50st or shorter	630 [22.22]	9.54 [0.3365]	560 [19.75]	8.92 [0.3146]		
	75st or longer	720 [25.40]	9.54 [0.3365]	760 [26.81]	8.92 [0.3146]		
25 [0.984]	50st or shorter	870 [30.69]	11.58 [0.4085]	795 [28.04]	10.89 [0.3841]		
	75st or longer	950 [33.51]	11.58 [0.4085]	870 [30.69]	10.89 [0.3841]		
32 [1.260]	50st or shorter	1200 [42.32]	17.4 [0.6138]	1151 [40.60]	15.08 [0.5319]		
	75st or longer	1400 [49.38]	17.4 [0.6138]	1344 [47.41]	15.08 [0.5319]		
40 [1.575]	50st or shorter	1520 [53.62]	18.98 [0.6695]	1380 [48.68]	17.15 [0.6049]		
	75st or longer	1720 [60.67]	18.98 [0.6695]	1580 [55.73]	17.15 [0.6049]		
50 [1.969]	50st or shorter	2600 [91.71]	28.5 [1.0053]	2434 [85.86]	25.4 [0.8959]		
	75st or longer	2970 [104.76]	28.5 [1.0053]	2840 [100.18]	25.4 [0.8959]		
63 [2.480]	50st or shorter	3130 [110.41]	31.79 [1.1213]	3030 [106.88]	29.11 [1.0268]		
	75st or longer	3430 [120.99]	31.79 [1.1213]	3400 [119.93]	29.11 [1.0268]		

# Dimensions of Stroke Adjusting Cylinder (mm)

Slide bearing type **SGDAP**  ×



●  $\phi 12, \phi 16$  (Drawings show  $\phi 16$ .)

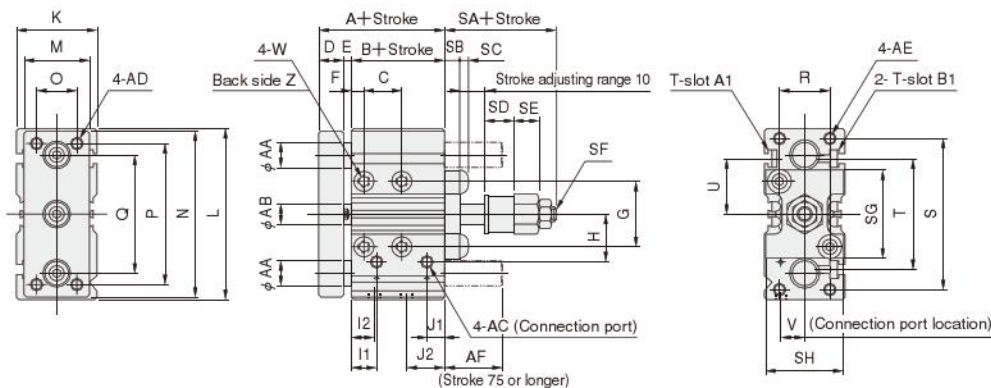

● T-slot A1, B1 dimensions

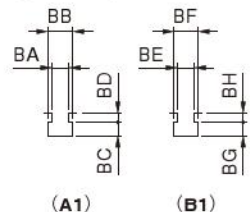

●  $\phi 20 \sim \phi 63$  (Drawings show  $\phi 32$ .)

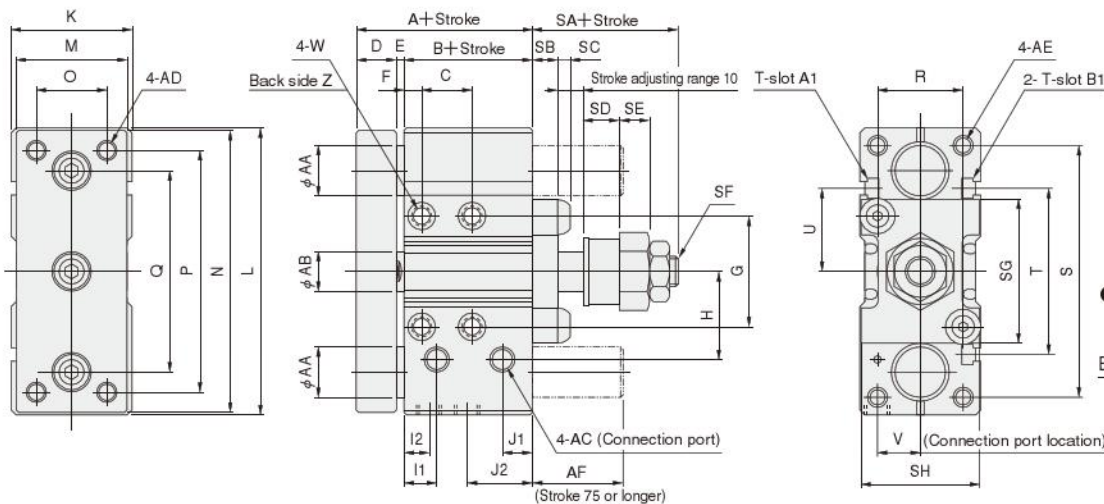

● T-slot A1, B1 dimensions

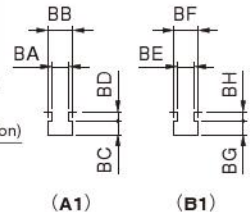

Code	Bore		C								D	E	F	G	H	I1	I2	J1	J2	K	L	M	N	O	P	Q	R	S	T	U	V <sup>Note</sup>	W
	A	B	Stroke																													
<b>12 [0.472]</b>	36	25	15	25	35	45	55	—	8	3	5	22	17	10	9	6	14	28	58	22	56	14	48	42	18	51	37	18.5	8.5	$\phi 4.2$ (Thru hole) Counterbore $\phi 8$ Depth 4.5		
<b>16 [0.630]</b>	40	27	15	25	35	45	55	—	10	3	5	26	19	10	9	7.5	16	32	68	26	66	16	56	47	20	60	44	22	9.5	$\phi 4.2$ (Thru hole) Counterbore $\phi 8$ Depth 4.5		
<b>20 [0.787]</b>	52	36	20	30	40	50	60	110	12	4	6	30	27	11	11	10	20	40	82	36	80	24	66	58	26	72	54	27	13.5	$\phi 5.2$ (Thru hole) Counterbore $\phi 9.5$ Depth 5.5		
<b>25 [0.984]</b>	54	38	20	30	40	50	60	110	12	4	6	33	29	12	12	10	21	42	92	38	90	26	76	63	30	80	54	27	14.5	$\phi 5.2$ (Thru hole) Counterbore $\phi 9.5$ Depth 5.5		
<b>32 [1.260]</b>	59	40	20	30	40	50	60	110	15	4	7	44	35	13	10	12	25	48	114	44	112	28	96	80	34	100	66	33	17	$\phi 6.8$ (Thru hole) Counterbore $\phi 11$ Depth 7		
<b>40 [1.575]</b>	63	44	20	30	40	50	60	110	15	4	7	52	40	14	14	13	25	54	124	50	122	34	106	90	40	106	82	41	18	$\phi 6.8$ (Thru hole) Counterbore $\phi 11$ Depth 7		
<b>50 [1.969]</b>	70	47	20	30	40	50	60	110	18	5	8	66	52.5	15.5	10	15	31	66	150	62	148	42	120	110	44	130	100	50	22	$\phi 8.6$ (Thru hole) Counterbore $\phi 14$ Depth 9		
<b>63 [2.480]</b>	70	47	20	30	40	50	60	110	18	5	8	78	60	17	10	14	31	76	162	72	160	52	132	122	44	144	120	60	24	$\phi 8.6$ (Thru hole) Counterbore $\phi 14$ Depth 9		

Note: The V dimension shows the side connection port location.

Code	Z	AA	AB	AC	AD	AE	AF	Stroke adjustment								T-slot		BA	BB	BC	BD	BE	BF	BG	BH
								SA	SB	SC	SD	SE	SF	SG	SH	A1	B1								
<b>12 [0.472]</b>	M5 X 0.8 Depth 8	8	6	M5 X 0.8	M4 X 0.7	M4 X 0.7 Depth 8	15	31.5	6	0.6	9.7	10	M5 X 21	32	27	M3 X 0.5	M4 X 0.7	3.3	5.8	3	1.5	4.3	7.3	3.5	2.5
<b>16 [0.630]</b>	M5 X 0.8 Depth 11	10	8	M5 X 0.8	M5 X 0.8	M5 X 0.8 Depth 10	23	34.4	6	3.4	11.5	10	M6 X 23	35.5	31	M4 X 0.7	M4 X 0.7	4.3	7.3	3.5	1.5	4.3	7.3	3.5	3
<b>20 [0.787]</b>	M6 X 1 Depth 12	14	10	Rc1/8	M6 X 1	M6 X 1 Depth 12	27	36.8	8	4	12	10	M8 X 25	42	36.5	M4 X 0.7	M5 X 0.8	4.3	7.3	4	3	5.3	8.3	4.5	3
<b>25 [0.984]</b>	M6 X 1 Depth 12	16	12	Rc1/8	M6 X 1	M6 X 1 Depth 12	28	40.5	8	4	12.5	12	M10 X 27	45	40.5	M4 X 0.7	M5 X 0.8	4.3	7.3	4	3	5.3	8.3	4.5	3
<b>32 [1.260]</b>	M8 X 1.25 Depth 16	20	16	Rc1/8	M8 X 1.25	M8 X 1.25 Depth 16	36	48.5	10	5	14.5	12	M14 X 31	58	48	M5 X 0.8	M5 X 0.8	5.3	8.3	4.5	3	5.3	8.3	4.5	3
<b>40 [1.575]</b>	M8 X 1.25 Depth 16	20	16	Rc1/8	M8 X 1.25	M8 X 1.25 Depth 16	32	47	10	5	14.5	12	M14 X 31	67	54	M5 X 0.8	M6 X 1	5.3	8.3	4.5	3	6.3	10.3	5.5	3
<b>50 [1.969]</b>	M10 X 1.5 Depth 20	25	20	Rc1/4	M10 X 1.5	M10 X 1.5 Depth 20	39	53	12	6	13	15	M18 X 35	83.5	62	M5 X 0.8	M8 X 1.25	5.3	8.3	4.5	3	8.3	13.3	7	4.5
<b>63 [2.480]</b>	M10 X 1.5 Depth 20	25	20	Rc1/4	M10 X 1.5	M10 X 1.5 Depth 20	39	54	12	6	13	15	M18 X 35	95.5	64	M5 X 0.8	M8 X 1.25	5.3	8.3	4.5	3	8.3	13.3	7	4.5

# Dimensions of Stroke Adjusting Cylinder (mm)

Rolling bearing type **SGDAPQ**  ×

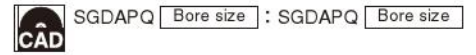

●  $\phi 12$ ,  $\phi 16$  (Drawings show  $\phi 16$ .)

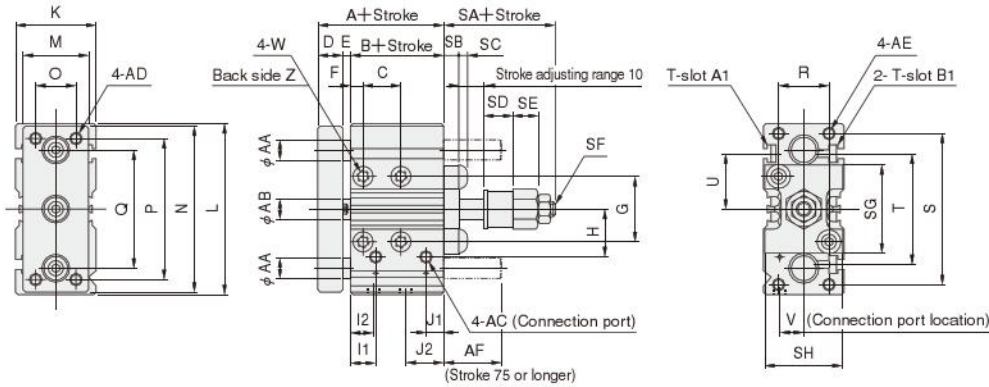

● T-slot A1, B1 dimensions

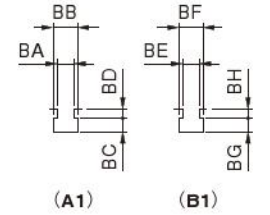

●  $\phi 20 \sim \phi 63$  (Drawings show  $\phi 32$ .)

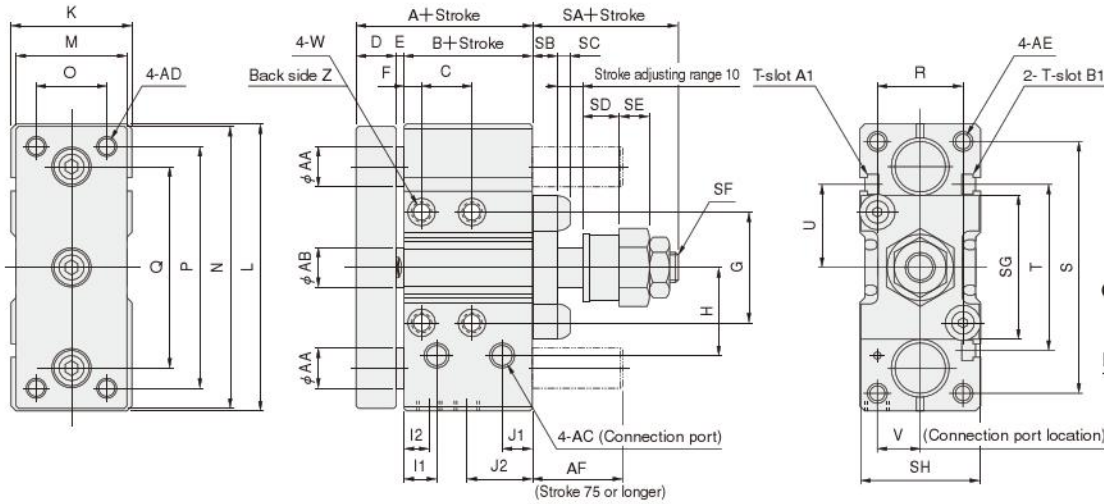

● T-slot A1, B1 dimensions

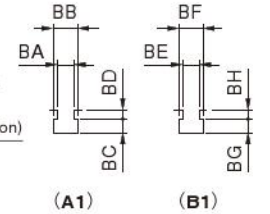

Code	Bore		C								D	E	F	G	H	I1	I2	J1	J2	K	L	M	N	O	P	Q	R	S	T	U	V <sup>Note</sup>	W
	A	B	10	20	30	40	50~100	125 or more																								
<b>12 [0.472]</b>	36	25	15	25	35	45	55	—	8	3	5	22	17	10	9	6	14	28	58	22	56	14	48	42	18	51	37	18.5	8.5	$\phi 4.2$ (Thru hole) Counterbore $\phi 8$ Depth 4.5		
<b>16 [0.630]</b>	40	27	15	25	35	45	55	—	10	3	5	26	19	10	9	7.5	16	32	68	26	66	16	56	47	20	60	44	22	9.5	$\phi 4.2$ (Thru hole) Counterbore $\phi 8$ Depth 4.5		
<b>20 [0.787]</b>	52	36	20	30	40	50	60	110	12	4	6	30	27	11	11	10	20	40	82	36	80	24	66	58	26	72	54	27	13.5	$\phi 5.2$ (Thru hole) Counterbore $\phi 9.5$ Depth 5.5		
<b>25 [0.984]</b>	54	38	20	30	40	50	60	110	12	4	6	33	29	12	12	10	21	42	92	38	90	26	76	63	30	80	54	27	14.5	$\phi 5.2$ (Thru hole) Counterbore $\phi 9.5$ Depth 5.5		
<b>32 [1.260]</b>	59	40	20	30	40	50	60	110	15	4	7	44	35	13	10	12	25	48	114	44	112	28	96	80	34	100	66	33	17	$\phi 6.8$ (Thru hole) Counterbore $\phi 11$ Depth 7		
<b>40 [1.575]</b>	63	44	20	30	40	50	60	110	15	4	7	52	40	14	14	13	25	54	124	50	122	34	106	90	40	106	82	41	18	$\phi 6.8$ (Thru hole) Counterbore $\phi 11$ Depth 7		
<b>50 [1.969]</b>	70	47	20	30	40	50	60	110	18	5	8	66	52.5	15.5	10	15	31	66	150	62	148	42	120	110	44	130	100	50	22	$\phi 8.6$ (Thru hole) Counterbore $\phi 14$ Depth 9		
<b>63 [2.480]</b>	70	47	20	30	40	50	60	110	18	5	8	78	60	17	10	14	31	76	162	72	160	52	132	122	44	144	120	60	24	$\phi 8.6$ (Thru hole) Counterbore $\phi 14$ Depth 9		

Note: The V dimension shows the side connection port location.

Code	Z	AA	AB	AC	AD	AE	AF	Stroke adjustment								T-slot		BA	BB	BC	BD	BE	BF	BG	BH
								SA	SB	SC	SD	SE	SF	SG	SH	A1	B1								
<b>12 [0.472]</b>	M5 X 0.8 Depth 8	6	6	M5 X 0.8	M4 X 0.7	M4 X 0.7 Depth 8	15	31.5	6	0.6	9.7	10	M5 X 21	32	27	M3 X 0.5	M4 X 0.7	3.3	5.8	3	1.5	4.3	7.3	3.5	2.5
<b>16 [0.630]</b>	M5 X 0.8 Depth 11	8	8	M5 X 0.8	M5 X 0.8	M5 X 0.8 Depth 10	23	34.4	6	3.4	11.5	10	M6 X 23	35.5	31	M4 X 0.7	M4 X 0.7	4.3	7.3	3.5	1.5	4.3	7.3	3.5	3
<b>20 [0.787]</b>	M6 X 1 Depth 12	12	10	Rc1/8	M6 X 1	M6 X 1 Depth 12	27	36.8	8	4	12	10	M8 X 25	42	36.5	M4 X 0.7	M5 X 0.8	4.3	7.3	4	3	5.3	8.3	4.5	3
<b>25 [0.984]</b>	M6 X 1 Depth 12	13	12	Rc1/8	M6 X 1	M6 X 1 Depth 12	28	40.5	8	4	12.5	12	M10 X 27	45	40.5	M4 X 0.7	M5 X 0.8	4.3	7.3	4	3	5.3	8.3	4.5	3
<b>32 [1.260]</b>	M8 X 1.25 Depth 16	16	16	Rc1/8	M8 X 1.25	M8 X 1.25 Depth 16	36	48.5	10	5	14.5	12	M14 X 31	58	48	M5 X 0.8	M5 X 0.8	5.3	8.3	4.5	3	5.3	8.3	4.5	3
<b>40 [1.575]</b>	M8 X 1.25 Depth 16	16	16	Rc1/8	M8 X 1.25	M8 X 1.25 Depth 16	32	47	10	5	14.5	12	M14 X 31	67	54	M5 X 0.8	M6 X 1	5.3	8.3	4.5	3	6.3	10.3	5.5	3
<b>50 [1.969]</b>	M10 X 1.5 Depth 20	20	20	Rc1/4	M10 X 1.5	M10 X 1.5 Depth 20	39	53	12	6	13	15	M18 X 35	83.5	62	M5 X 0.8	M8 X 1.25	5.3	8.3	4.5	3	8.3	13.3	7	4.5
<b>63 [2.480]</b>	M10 X 1.5 Depth 20	20	20	Rc1/4	M10 X 1.5	M10 X 1.5 Depth 20	39	54	12	6	13	15	M18 X 35	95.5	64	M5 X 0.8	M8 X 1.25	5.3	8.3	4.5	3	8.3	13.3	7	4.5

# SENSOR SWITCHES FOR JIG CYLINDERS WITH GUIDES

Solid State Type, Reed Switch Type

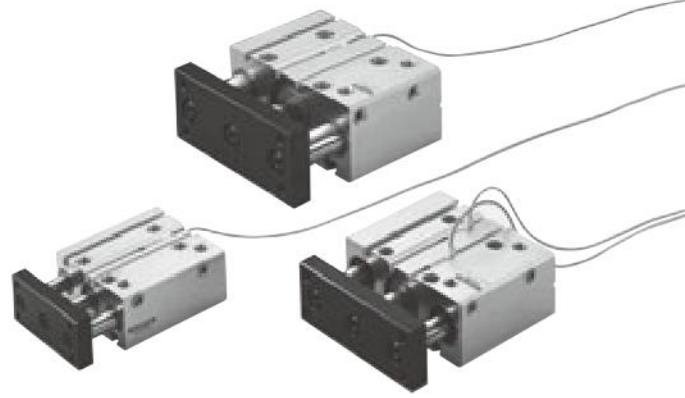

## Symbols

### ● Standard cylinder

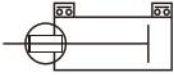

### ● Stroke adjusting cylinder

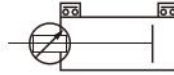

### ● End keep cylinder (Head side)

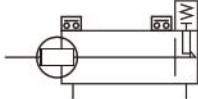

### ● End keep cylinder (Rod side)

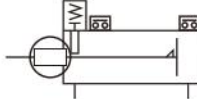

## Order Codes



**Lead wire length**  
**A** — 1000mm [39in.]  
**B** — 3000mm [118in.]

#### Cylinder specification

**Blank** — Standard,  
 Stroke adjusting,  
 End keep

**CS** — For Clean  
 systems

#### Sensor switch

**ZE135** — Solid state type with indicator lamp

**ZE235** — Solid state type with indicator lamp

**ZE101** — Reed switch type without indicator lamp

**ZE201** — Reed switch type without indicator lamp

**ZE155** — Solid state type with indicator lamp

**ZE255** — Solid state type with indicator lamp

**ZE102** — Reed switch type with indicator lamp

**ZE202** — Reed switch type with indicator lamp

DC10V~28V Horizontal lead wire

DC10V~28V Vertical lead wire

DC5V~28V Horizontal lead wire

AC85~115V

DC5V~28V Vertical lead wire

AC85~115V

DC4.5V~28V Horizontal lead wire

DC4.5V~28V Vertical lead wire

DC10V~28V Horizontal lead wire

AC85~115V

DC10V~28V Vertical lead wire

AC85~115V

● For details of sensor switches, see p.1544.

## Minimum Cylinder Strokes When Using Sensor Switches

### ● Solid state type

Bore size mm [in.]	2 pcs. mounting <sup>Note</sup>		1 pc. mounting
	1-surface mounting	2-surface mounting	
12~63 [0.472~2.480]	10		5

Note: 2 pcs. mounting is possible at stroke 5mm.  
Be aware, however, that overlapping may occur.

### ● Reed switch type

Bore size mm [in.]	2 pcs. mounting		1 pc. mounting
	1-surface mounting	2-surface mounting	
12~63 [0.472~2.480]	10		10

## Moving Sensor Switch

- Loosening the mounting screw allows the sensor switch to be moved along the switch mounting groove on the cylinder body.
- Tighten the mounting screw with a tightening torque of 0.1~0.2N·m [0.9~1.8in·lbf].

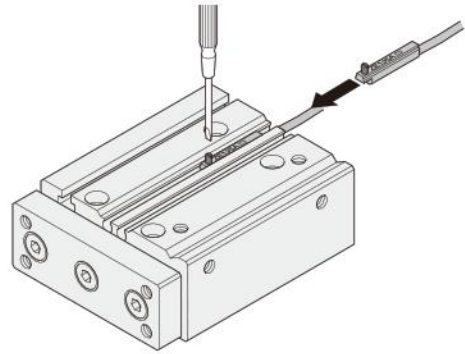

## Sensor Switch Operating Range, Response Differential, and Maximum Sensing Location

### ● Operating range: $\ell$

The distance the piston travels in one direction, while the switch is in the ON position.

### ● Response differential: C

The distance between the point where the piston turns the switch ON and the point where the switch is turned OFF as the piston travels in the opposite direction.

### ● Solid state type

Item	Bore size							
	12 [0.472]	16 [0.630]	20 [0.787]	25 [0.984]	32 [1.260]	40 [1.575]	50 [1.969]	63 [2.480]
Operating range: $\ell$	2~4 [0.079~0.157]	2~5 [0.079~0.197]	3.5~7.5 [0.138~0.295]	4~8 [0.157~0.315]	3~7 [0.118~0.276]	3.5~7.5 [0.138~0.295]	3.5~7.5 [0.138~0.295]	4~8.5 [0.157~0.335]
Response differential: C	1.0 [0.039] or less							
Maximum sensing location <sup>Note</sup>	6 [0.236]							

Note: This is the length measured from the switch's opposite end side to lead wire.  
Remark: The above table shows reference values.

### ● Reed switch type

Item	Bore size							
	12 [0.472]	16 [0.630]	20 [0.787]	25 [0.984]	32 [1.260]	40 [1.575]	50 [1.969]	63 [2.480]
Operating range: $\ell$	5.5~8 [0.217~0.315]	6.5~9 [0.256~0.354]	10~13 [0.394~0.512]	11.5~15 [0.453~0.591]	9~11.5 [0.354~0.453]	10~13.5 [0.394~0.531]	10.5~14.5 [0.413~0.571]	11~15.5 [0.433~0.610]
Response differential: C	1.0 [0.039] or less	1.5 [0.059] or less						
Maximum sensing location <sup>Note</sup>	10 [0.394]							

Note: This is the length measured from the switch's opposite end side to lead wire.  
Remark: The above table shows reference values.

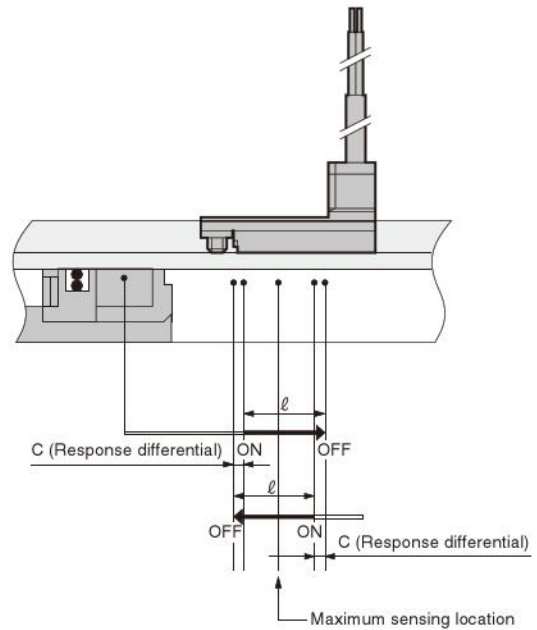

## When Mounting Cylinders with Sensor Switches in Close Proximity

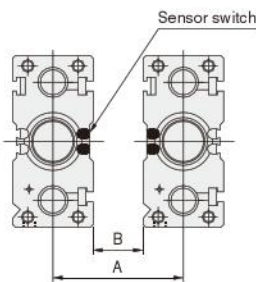

When mounting cylinders in close proximity, install the cylinder so that it exceeds the values in the table below.

### The end plates are the same side

Bore size	Solid state type		Reed switch type	
	A	B	A	B
12 [0.472]	33 [1.299]		28 [1.102]	
16 [0.630]	37 [1.457]	5 [0.197]	32 [1.260]	
20 [0.787]	45 [1.772]		40 [1.575]	
25 [0.984]	50 [1.969]		42 [1.654]	
32 [1.260]	56 [2.205]	8 [0.315]	48 [1.890]	
40 [1.575]	62 [2.441]		54 [2.126]	
50 [1.969]	78 [3.071]		66 [2.598]	
63 [2.480]	88 [3.465]	12 [0.472]	76 [2.992]	

### The end plates are the opposite side

Bore size	Solid state type		Reed switch type	
	A	B	A	B
12 [0.472]	34 [1.339]		28 [1.102]	
16 [0.630]	38 [1.496]	6 [0.236]	32 [1.260]	
20 [0.787]	46 [1.811]		40 [1.575]	
25 [0.984]	54 [2.126]		42 [1.654]	
32 [1.260]	60 [2.362]	12 [0.472]	48 [1.890]	
40 [1.575]	66 [2.598]		54 [2.126]	
50 [1.969]	84 [3.307]		66 [2.598]	
63 [2.480]	94 [3.701]	18 [0.709]	76 [2.992]	

## Mounting and Removing Sensor Switches

In Jig Cylinders with Guides of φ12 ~ φ63, be aware that sensor switches cannot be mounted or removed when strokes of 10mm or shorter mounted in the application shown below.

### Bottom mounting



### Right angled mounting (2 surfaces and 3 surfaces)

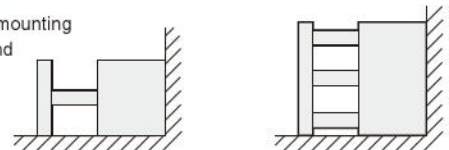

※ For strokes of 20mm or longer, sensor switches can be mounted and removed when the plate (rods extend) is extended.

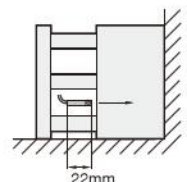

# Mounting Location of End of Stroke Detection Sensor Switch

When the sensor switch is mounted in the locations shown below (the figures in the tables are reference values), the magnet comes to the maximum sensing location of the sensor switch at the end of the stroke.

## ● Standard cylinder

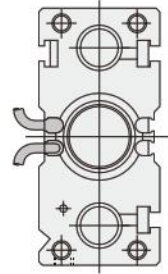
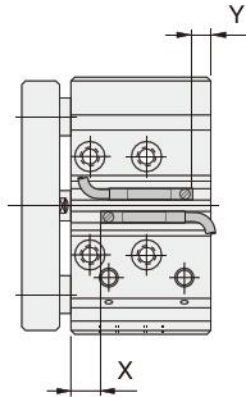

※ The scraper specification has a configuration of the standard cylinder body length +10mm [0.394in.], with the retracted side connection port location shifted 10mm [0.394in.] toward the head side.

### ■ Solid state type

mm [in.]

Code		Bore size							
		12	16	20	25	32	40	50	63
		[0.472]	[0.630]	[0.787]	[0.984]	[1.260]	[1.575]	[1.969]	[2.480]
X	Without scraper	9.5	11	14	16	15	16.5	16.5	16.5
	With scraper	19.5	21	24	26	25	26.5	26.5	26.5
Y	Without scraper	3.5	4.5	10	10	13	15.5	18.5	18.5
	With scraper	3.5	4.5	10	10	13	15.5	18.5	18.5

### ■ Reed switch type

mm [in.]

Code		Bore size							
		12	16	20	25	32	40	50	63
		[0.472]	[0.630]	[0.787]	[0.984]	[1.260]	[1.575]	[1.969]	[2.480]
X	Without scraper	5.5	7	10	12	11	12.5	12.5	12.5
	With scraper	15.5	17	20	22	21	22.5	22.5	22.5
Y	Without scraper	0	0	6	6	9	11.5	14.5	14.5
	With scraper	0	0	6	6	9	11.5	14.5	14.5

## ● Stroke adjusting cylinder

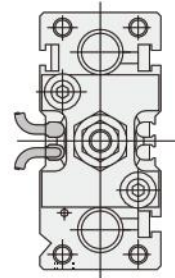
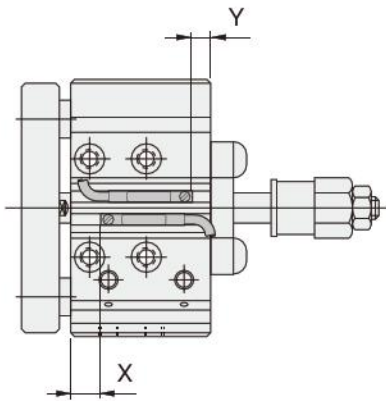

### ■ Solid state type

mm [in.]

Code		Bore size							
		12	16	20	25	32	40	50	63
		[0.472]	[0.630]	[0.787]	[0.984]	[1.260]	[1.575]	[1.969]	[2.480]
X		7	7	10	11	15	16.5	16.5	16.5
Y		6	8	14	15	13	15.5	18.5	18.5

### ■ Reed switch type

mm [in.]

Code		Bore size							
		12	16	20	25	32	40	50	63
		[0.472]	[0.630]	[0.787]	[0.984]	[1.260]	[1.575]	[1.969]	[2.480]
X		3	3	6	7	11	12.5	12.5	12.5
Y		2	4	10	11	9	11.5	14.5	14.5

When the sensor switch is mounted in the locations shown below (the figures in the tables are reference values), the magnet comes to the maximum sensing location of the sensor switch at the end of the stroke.

● Head side end keep cylinder

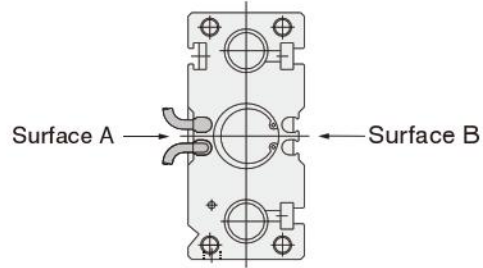
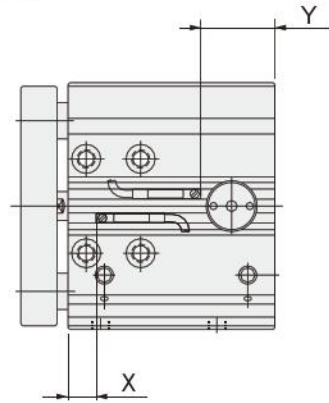

■ Solid state type

		mm [in.]							
Code \ Bore size	12	16	20	25	32	40	50	63	
	[0.472]	[0.630]	[0.787]	[0.984]	[1.260]	[1.575]	[1.969]	[2.480]	
X	9.5 [0.374]	11 [0.433]	14 [0.551]	16 [0.630]	15 [0.591]	16.5 [0.650]	16.5 [0.650]	16.5 [0.650]	
Y	23.5 [0.925]	24.5 [0.965]	30 [1.181]	30 [1.181]	33 [1.299]	35.5 [1.398]	48.5 [1.909]	48.5 [1.909]	

Remark: A sensor switch cannot be mounted on surface A when the cylinder is St=10 and a head side end keep. (Can be mounted on surface B)

■ Reed switch type

		mm [in.]							
Code \ Bore size	12	16	20	25	32	40	50	63	
	[0.472]	[0.630]	[0.787]	[0.984]	[1.260]	[1.575]	[1.969]	[2.480]	
X	5.5 [0.217]	7 [0.276]	10 [0.394]	12 [0.472]	11 [0.433]	12.5 [0.492]	12.5 [0.492]	12.5 [0.492]	
Y	20 [0.787]	20 [0.787]	26 [1.024]	26 [1.024]	29 [1.142]	31.5 [1.240]	44.5 [1.752]	44.5 [1.752]	

Remark: A sensor switch cannot be mounted on surface A when the cylinder is St=10 and a head side end keep. (Can be mounted on surface B)

**Caution:** As can be seen in the diagram to the right, when a sensor switch is mounted on a head side end keep cylinder (-HL), both the lead wires cannot be taken out on the head side. They can, however, be mounted on surface B.

Because the sensor switch interferes with the end keep function section.

● Rod side end keep cylinder

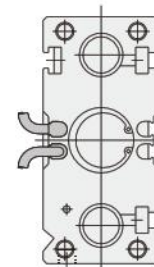
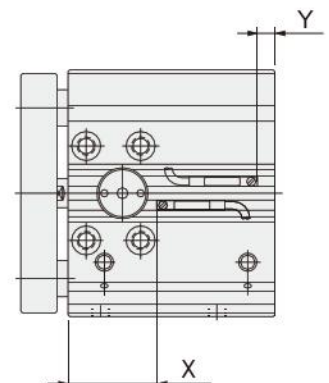

■ Solid state type

		mm [in.]							
Code \ Bore size	12	16	20	25	32	40	50	63	
	[0.472]	[0.630]	[0.787]	[0.984]	[1.260]	[1.575]	[1.969]	[2.480]	
X	29.5 [1.161]	31 [1.220]	34 [1.339]	36 [1.417]	35 [1.378]	36.5 [1.437]	46.5 [1.831]	46.5 [1.831]	
Y	3.5 [0.138]	4.5 [0.177]	10 [0.394]	10 [0.394]	13 [0.512]	15.5 [0.610]	18.5 [0.728]	18.5 [0.728]	

■ Reed switch type

		mm [in.]							
Code \ Bore size	12	16	20	25	32	40	50	63	
	[0.472]	[0.630]	[0.787]	[0.984]	[1.260]	[1.575]	[1.969]	[2.480]	
X	25.5 [1.004]	27 [1.063]	30 [1.181]	32 [1.260]	31 [1.220]	32.5 [1.280]	42.5 [1.673]	42.5 [1.673]	
Y	0 [0]	0 [0]	6 [0.236]	6 [0.236]	9 [0.354]	11.5 [0.453]	14.5 [0.571]	14.5 [0.571]	

## Mounting Location of End of Stroke Detection Sensor Switch

When the sensor switch is mounted in the locations shown below (the figures in the tables are reference values), the magnet comes to the maximum sensing location of the sensor switch at the end of the stroke.

### ● Cylinders for clean systems

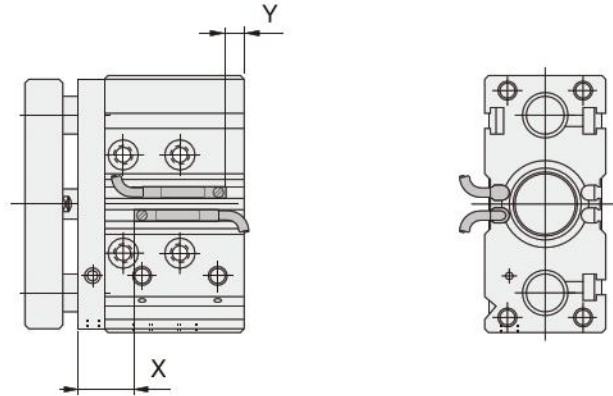

#### ■ Solid state type

mm [in.]

Code	Bore size	mm [in.]							
		12	16	20	25	32	40	50	63
X		19.5	21	24	26	25	26.5	26.5	26.5
		[0.766]	[0.827]	[0.945]	[1.024]	[0.984]	[1.043]	[1.043]	[1.043]
Y		3.5	4.5	10	10	13	15.5	18.5	18.5
		[0.138]	[0.177]	[0.394]	[0.394]	[0.512]	[0.610]	[0.728]	[0.728]

#### ■ Reed switch type

mm [in.]

Code	Bore size	mm [in.]							
		12	16	20	25	32	40	50	63
X		15.5	17	20	22	21	22.5	22.5	22.5
		[0.610]	[0.669]	[0.787]	[0.866]	[0.827]	[0.886]	[0.886]	[0.886]
Y		0	0	6	6	9	11.5	14.5	14.5
		[0]	[0]	[0.236]	[0.236]	[0.354]	[0.453]	[0.571]	[0.571]