



CAD drawing data catalog
is available.



KOGANEI

ACTUATORS GENERAL CATALOG

SD CYLINDERS CONTENTS

SD CYLINDERS

Features	541
Handling Instructions and Precautions	543
Standard Cylinders	546
Heavy Duty Rod Cylinders	552
Double Rod Cylinders	558
Tandem Cylinders	562
Dual Stroke Cylinders	569
Stroke Adjusting Cylinders	574
Low Hydraulic Cylinders	583
Sensor Switches	589
Rod End Accessories, Bellows	591

Discontinued



Caution

Before use, be sure to read the "Safety Precautions" on p. 57.

KOGANEI SD CYLINDERS

Power joined with advanced functionality

The power of the SD cylinder as the basic large cylinders has been joined with advanced functionality.

● All bore sizes (ϕ 125 [4.921in.] ~ ϕ 200 [7.874in.]) are non-lubrication types.

Although lubrication was previously required, the installation of grease pockets made it possible to make them non-lubrication types.

● Cylinder with magnet is standard.

Cylinders with magnet type are now standard for bore sizes ϕ 125 [4.921in.] ~ ϕ 160 [6.299in.], making them easier to use.

● Full series line-up

	Standard cylinders	Heavy duty rod cylinders	Double rod cylinders	Tandem cylinders	Dual stroke cylinders	Push side stroke adjusting cylinders	Pull side stroke adjusting cylinders	Low hydraulic cylinders
Standard specification	Standard products	Standard products	Standard products	Standard products	Standard products	Standard products	Standard products	Standard products
Cylinder with magnet specification	Standard products	Standard products	Standard products	Standard products	Standard products	Standard products	Standard products	Standard products
With bellows	Standard products	Special specifications	Standard products	Standard products	Standard products	Standard products	Standard products	Standard products
Heavy duty dust scraper specification	Standard products	Standard products	Special specifications	Special specifications	Special specifications	Special specifications	Special specifications	Standard products
SUS rod specification	Standard products	Standard products	Special specifications	Special specifications	Special specifications	Special specifications	Special specifications	Special specifications

■ : Standard products
 □ : Special specifications (Consult us about the availability, and delivery dates.)

Remark: Consult us for combinations other than those shown here.

Discontinued



INFORMATION

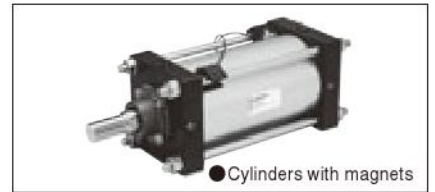
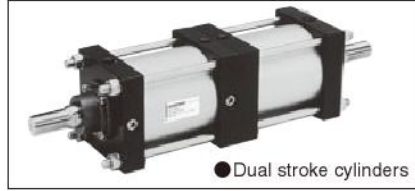
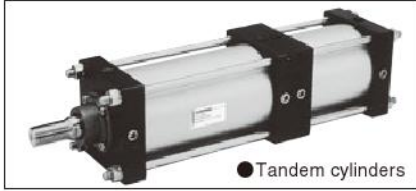
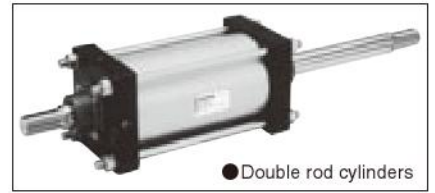
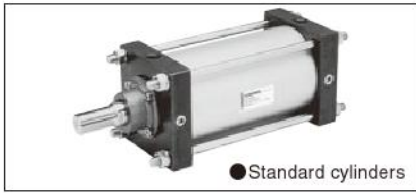

SD CYLINDERS

Mounting Accessory

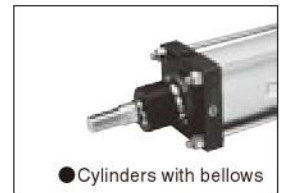
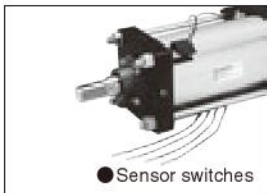
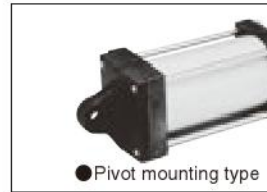
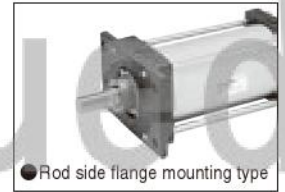
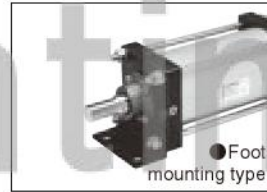
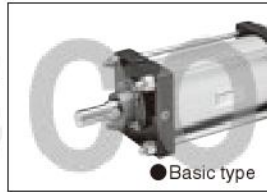

Handling Instructions and Precautions



General precautions

Media

1. Use air for the media. For the use of any other media, consult us.
2. To operate the SD cylinder, use clean, compressed air that contains no moisture, dust, oxidized oil, and other impurities. Install an air filter (filtration of a minimum 40 μm) near the SD cylinder or valve to remove collected liquid or dust. In addition, drain the air filter periodically.

Piping

1. Always thoroughly blow off (use compressed air) the tubing before connecting it to the SD cylinder. Entering chips, sealing tape, rust, etc., generated during piping work could result in air leaks or other defective operation.
2. When screwing in piping or fittings to the SD cylinder, tighten to the requisite tightening torque shown below.

Connecting thread	Tightening torque N·m [ft·lbf]
Rc1/2	27~29 [19.9~21.4]
Rc3/4	27~29 [19.9~21.4]

Atmosphere

If using in locations subject to dripping water, dripping oil, etc., or to large amounts of dust, use a cover to protect the unit.

Lubrication

The non-lubrication specification means that lubrication is not required. If lubrication is required, use Turbine Oil Class 1 (ISO VG32) or lithium soap-based grease No.2 or equivalent. Also, be sure to limit the lubrication volume to an absolute minimum. Avoid using spindle oil or machine oil.

Piston Rod Diameter Change and Repair Kits

On April 7, 2000, we changed the piston rod diameters of SD cylinders with bore size of 125mm [4.921in.] and 140mm [5.512in.], as well as some of the seals. For this reason, the new repair kit **SRK-NSD125, 140 (SRK-NSDH125, 140)** cannot be used with products manufactured before the change. For repair kits for products manufactured earlier to the change, consult us.

	Product label	Piston rod diameter	Repair kit
After the change			SRK-NSD125 SRK-NSD140 SRK-NSDH125 SRK-NSDH140
Before the change			Consult us

Selection of Cylinder and Valve

1. Select the cylinder bore in accordance with thrust requirements. 2. Determine the valve size in accordance with cylinder bore and speed.

How to read the table

Cylinder thrust N 20000 15000 10000 7000 5000 3000 2000 1000 700	Available cylinder bore size mm [in.] (Pressure area mm ² [in. ²])	Cylinder speed mm/s 1000 800 200	Applicable valve series
	125 (12271) [4.921] [19.02]		430 Series
	140 (15393) [5.512] [23.86]		600 Series
	160 (20106) [6.299] [31.16]		
	180 (25446) [7.087] [39.44]		750 Series
	200 (31415) [7.874] [48.69]		

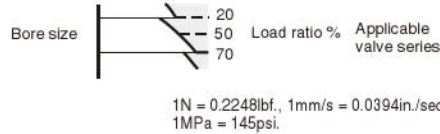
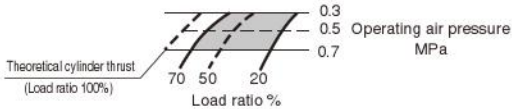

1. Selection of bore size

For cases where a 3000N [674lbf.] thrust is required with air pressure of 0.5MPa [73psi.], three bore sizes, φ 125 (load ratio of about 50%), φ 140 (load ratio of about 40%), and φ 160 (load ratio of about 30%) can be selected.

2. Selection of the applicable valve

When required cylinder speed is 200mm/s [7.9in./sec.], the load ratio at φ 125 is about 50%, which means that the applicable valve should be the 430 series. For φ 140, the load ratio is about 40%, which calls for the 600 series. In the same way, the load ratio at φ 160 is about 30%, and the applicable valve should be the 600 series.

3. Precautions concerning selection

For situations that require high-speed operation, or fixed-speed operation for fluctuating loads, select larger bore sizes and load ratios of 50% or less. Select sizes with allowance for valves, piping, and fittings, as well.

SD CYLINDERS

Air Flow Rate and Air Consumption

While the air cylinder's air flow rate and air consumption can be found through the following calculations, the quick reference chart to the right provides the answers more conveniently.

Air flow rate

$$Q_1 = \frac{\pi D^2}{4} \times L \times \frac{60}{t} \times \frac{P+0.101}{0.101} \times 10^{-6}$$

Air consumption

$$Q_2 = \frac{\pi D^2}{4} \times L \times 2 \times n \times \frac{P+0.101}{0.101} \times 10^{-6}$$

- Q₁ : Required air flow rate for cylinder ℓ /min (ANR)
- Q₂ : Air consumption of cylinder ℓ /min (ANR)
- D : Cylinder tube inner diameter mm
- L : Cylinder stroke mm
- t : Time required for cylinder to travel 1 stroke s
- n : Number of cylinder reciprocations per minute times/min
- P : Pressure MPa

Air flow rate

$$Q_1' = \frac{\pi D'^2}{4} \times L' \times \frac{60}{t} \times \frac{P'+14.7}{14.7} \times \frac{1}{1728}$$

Air consumption

$$Q_2' = \frac{\pi D'^2}{4} \times L' \times 2 \times n \times \frac{P'+14.7}{14.7} \times \frac{1}{1728}$$

- Q₁' : Required air flow rate for cylinder ft³/min. (ANR)*
- Q₂' : Air consumption of cylinder ft³/min. (ANR)*
- D' : Cylinder tube inner diameter in.
- L' : Cylinder stroke in.
- t : Time required for cylinder to travel 1 stroke sec.
- n : Number of cylinder reciprocations per minute times/min.
- P' : Pressure psi.

* Refer to p.54 for an explanation of ANR.

Air consumption for each 1mm [0.0394in.] stroke cm³ [in.³]/reciprocation (ANR)

Bore size mm [in.]	Air pressure MPa [psi.]								
	0.1 [15]	0.2 [29]	0.3 [44]	0.4 [58]	0.5 [73]	0.6 [87]	0.7 [102]	0.8 [116]	0.9 [131]
125 [4.921]	48.8 [2.978]	73.1 [4.461]	97.4 [5.944]	121.7 [7.427]	146.0 [8.910]	170.3 [10.392]	194.6 [11.875]	218.9 [13.358]	243.2 [14.841]
140 [5.512]	61.3 [3.741]	91.8 [5.602]	122.2 [7.457]	152.7 [9.318]	183.2 [11.180]	213.7 [13.041]	244.2 [14.902]	274.6 [16.757]	305.1 [18.618]
160 [6.299]	80.0 [4.882]	119.8 [7.311]	159.7 [9.746]	199.5 [12.174]	239.3 [14.603]	279.1 [17.032]	318.9 [19.461]	358.7 [21.889]	398.5 [24.318]
180 [7.087]	101.3 [6.182]	151.7 [9.257]	202.1 [12.333]	252.5 [15.409]	302.8 [18.478]	353.2 [21.554]	403.6 [24.629]	454.0 [27.705]	504.4 [30.780]
200 [7.874]	125.0 [7.628]	187.3 [11.430]	249.5 [15.225]	311.7 [19.021]	373.9 [22.817]	436.1 [26.613]	498.3 [30.408]	560.5 [34.204]	622.7 [38.000]

The figures in the table show the air flow rate and air consumption when an air cylinder makes 1 reciprocation with stroke of 1mm [0.039in.]. The air flow rate and air consumption actually required is found by the following calculations.

● Finding the air flow rate (for selecting F.R.L., valves, etc.)

Example 1: When operating an air cylinder with bore size of 125mm [4.921in.] at speed of 200mm/s [7.9in./sec.], under air pressure of 0.5MPa [73psi.].

$$146.0 \times \frac{1}{2} \times 200 \times 10^{-3} = 14.6 \ell / s [0.515 \text{ft}^3/\text{sec.}] \text{ (ANR)}$$

(The flow rate per minute at this time is $146.0 \times \frac{1}{2} \times 200 \times 60 \times 10^{-3} = 876 \ell / \text{min}$ [30.9ft³/min.] (ANR).)

● Finding the air consumption

Example 1: When operating an air cylinder with bore size of 125mm [4.921in.] and stroke of 100mm, under air pressure of 0.5MPa [73psi.] for 1 reciprocation.

$$146.0 \times 100 \times 10^{-3} = 14.6 \ell [0.515 \text{ft}^3] / \text{reciprocation (ANR)}$$

Example 2: When operating an air cylinder with bore size of 125mm [4.921in.] and stroke of 100mm, under air pressure of 0.5MPa [73psi.] for 10 reciprocations per minute.

$$146.0 \times 100 \times 10 \times 10^{-3} = 146 \ell / \text{min} [5.15 \text{ft}^3/\text{min.}] \text{ (ANR)}$$

Cylinder Thrust

Select a suitable cylinder bore size considering the load and air pressure to obtain the required thrust.

Since the figures in the table are calculated values, select a bore size that results in a load ratio (load ratio = $\frac{\text{Load}}{\text{Calculated value}}$) of 70% or less (50% or less for high speed application).

Bore size mm [in.]	Rod dia. mm [in.]	Operation	Pressure area mm ² [in. ²]	Air pressure MPa [psi.]										N [lbf.]
				0.1 [15]	0.2 [29]	0.3 [44]	0.4 [58]	0.5 [73]	0.6 [87]	0.7 [102]	0.8 [116]	0.9 [131]	1 [145]	
125 [4.921]	35 (40) [1.378 (1.575)]	Push side	12271 [19.020]	1227 [276]	2454 [552]	3681 [827]	4908 [1103]	6136 [1379]	7363 [1655]	8590 [1931]	9817 [2207]	11044 [2483]	12271 [2759]	
		Pull side	11310 (11015) [17.531 (17.073)]	1131 (1102) [254 (248)]	2262 (2203) [508 (495)]	3393 (3305) [763 (743)]	4524 (4406) [1017 (990)]	5655 (5508) [1271 (1238)]	6786 (6609) [1525 (1486)]	7917 (7711) [1780 (1734)]	9048 (8812) [2034 (1981)]	10179 (9914) [2288 (2229)]	11310 (11015) [2542 (2476)]	
140 [5.512]	35 (40) [1.378 (1.575)]	Push side	15393 [23.859]	1539 [346]	3079 [692]	4618 [1038]	6157 [1384]	7697 [1730]	9236 [2076]	10775 [2422]	12314 [2768]	13854 [3115]	15393 [3461]	
		Pull side	14432 (14137) [22.370 (21.912)]	1443 (1414) [324 (318)]	2886 (2827) [649 (636)]	4330 (4241) [973 (953)]	5773 (5655) [1298 (1271)]	7216 (7069) [1622 (1589)]	8659 (8482) [1947 (1907)]	10102 (9896) [2271 (2225)]	11545 (11310) [2595 (2543)]	12989 (12723) [2920 (2860)]	14432 (14137) [3244 (3178)]	
160 [6.299]	40 (45) [1.575 (1.772)]	Push side	20106 [31.164]	2011 [452]	4021 [904]	6032 [1356]	8042 [1808]	10053 [2260]	12064 [2712]	14074 [3164]	16085 [3616]	18095 [4068]	20106 [4520]	
		Pull side	18849 (18515) [29.216 (28.698)]	1885 (1852) [424 (416)]	3770 (3703) [847 (832)]	5655 (5555) [1271 (1249)]	7540 (7406) [1695 (1665)]	9425 (9258) [2119 (2081)]	11309 (11109) [2542 (2497)]	13194 (12961) [2966 (2914)]	15079 (14812) [3390 (3330)]	16964 (16664) [3814 (3746)]	18849 (18515) [4237 (4162)]	
180 [7.087]	45 (50) [1.772 (1.969)]	Push side	25446 [39.441]	2545 [572]	5089 [1144]	7634 [1716]	10178 [2288]	12723 [2860]	15268 [3432]	17812 [4004]	20357 [4576]	22901 [5148]	25446 [5720]	
		Pull side	23856 (23483) [36.977 (36.399)]	2386 (2348) [536 (528)]	4771 (4697) [1073 (1056)]	7157 (7045) [1609 (1584)]	9542 (9393) [2145 (2112)]	11928 (11742) [2681 (2640)]	14314 (14090) [3218 (3167)]	16699 (16438) [3754 (3695)]	19085 (18786) [4290 (4223)]	21470 (21135) [4827 (4751)]	23856 (23483) [5363 (5279)]	
200 [7.874]	50 (60) [1.969 (2.362)]	Push side	31415 [48.693]	3142 [706]	6283 [1412]	9425 [2119]	12566 [2825]	15708 [3531]	18849 [4237]	21991 [4944]	25132 [5650]	28274 [6356]	31415 [7062]	
		Pull side	29452 (28588) [45.651 (44.311)]	2945 (2859) [662 (643)]	5890 (5718) [1324 (1285)]	8836 (8576) [1986 (1928)]	11781 (11435) [2648 (2571)]	14726 (14294) [3310 (3213)]	17671 (17153) [3972 (3856)]	20616 (20012) [4635 (4499)]	23562 (22870) [5297 (5141)]	26507 (25729) [5959 (5784)]	29452 (28588) [6621 (6427)]	

Remark: Figures in parentheses () are for heavy duty rod cylinders.

Discontinued

Inner Construction and Major Parts

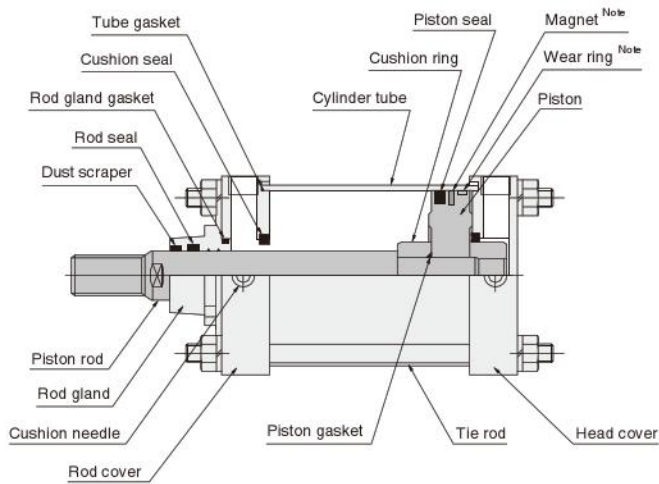

Note: For cylinder with magnet

● Cushion

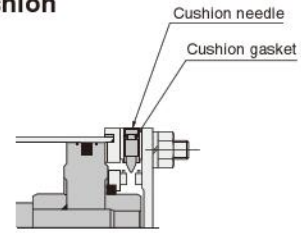

● With heavy duty dust scraper

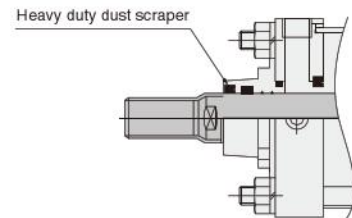

Major Parts and Materials

Parts	Bore size mm	125	140	160	180	200
Cylinder tube	Standard cylinder	Steel pipe (inside: hard chrome plated, outside: silver metallic painted)				
	Cylinder with magnet	Aluminum alloy (hard anodized)			—	
Piston		Cast iron ^{Note}				
Piston rod		Steel (hard chrome plated) (-RS : SUS)				
Cushion ring		Mild steel (zinc plated)				
Rod cover		Mild steel (black oxide)				
Head cover						
Tie rod		Mild steel (zinc plated)				
Rod gland		Aluminum alloy (hard anodized)				
Wear ring		Plastic				
Magnet		Rubber magnet				

Parts	Bore size mm	125	140	160	180	200
Seal		Synthetic rubber (NBR)				
Foot mounting bracket		Mild steel (painted)				
Flange mounting bracket		Cast iron (manganese treated)				
Clevis mounting bracket						
Pivot mounting bracket						
Trunnion mounting bracket		Cast iron (manganese treated)				
Bellows		Nylon tarpaulin				
I type knuckle		Mild steel (alkali coloring)				
Y type knuckle		Cast iron (manganese treated)				
Pin		Steel (zinc plated)				

Note : The cylinder with magnet is aluminum alloy.

Seals

Item	Dust scraper		Rod seal ★	Rod gland gasket	Cylinder tube gasket ★	Cushion seal	Piston seal ★	Piston gasket	Cushion gasket
	Standard type ★	Heavy duty type							
Bore size mm	Quantity	1	1	1	2	2	1	1	2
125	SDR-35	SCB-35	PNY-35	G-50	S-120	PCS-50	PWP-125N	G-25	P-7
140	SDR-35	SCB-35	PNY-35	G-50	S-135	PCS-50	PWP-140N	G-25	P-7
160	SDR-40	SCB-40	PNY-40	G-50	#160	PCS-50	PWP-160N	G-25	P-7
180	SDR-45	SCB-45	PNY-45	G-60	#180	PCS-60	PSD-180	G-35	P-7
200	SDR-50	SCB-50	PNY-50	G-60	#200	PCS-60	PSD-200	G-35	P-7

Remark: Items marked with a star (★) are available as repair kits. The order code is the **SRK-NSD** [Bore size].

Note that the contents of a repair kit is 1 dust scraper, 1 rod seal, 1 piston seal, and 2 cylinder tube gaskets.

Note, however, that the repair kits with bore size of 125mm and 140mm cannot be used with SD cylinders manufactured prior to April 6, 2000 (because the piston rod diameters have been changed). For details, see p.543.

Mass

Bore size mm [in.]	Zero stroke mass						Additional mass for each 1mm [0.0394in.] stroke	Mass of 1 sensor switch (With holder) ^{Note}		Additional mass		
	Basic type	Foot mounting type	Flange mounting type	Clevis mounting type (With pin)	Pivot mounting type	Trunnion mounting type		ZC□□□	CS□T	Nut	Y type knuckle (With pin)	I type knuckle
125 [4.921]	14.8 [32.6] (13.2 [29.1])	16.5 [36.4] (14.9 [32.9])	17.3 [38.1] (15.7 [34.6])	18.7 [41.2] (17.1 [37.7])	18.3 [40.4] (16.7 [36.8])	18.2 [40.1] (16.6 [36.6])	0.0256 [0.0564] (0.0167 [0.0368])	0.07 [0.15]	0.07 [0.15]	0.2 [0.4]	1.5 [3.3]	1.5 [3.3]
140 [5.512]	17.8 [39.2] (15.8 [34.8])	20.4 [45.0] (18.4 [40.6])	22.4 [49.4] (20.4 [45.0])	23.0 [50.7] (21.0 [46.3])	22.6 [49.8] (20.6 [45.4])	22.3 [49.2] (20.3 [44.8])	0.0291 [0.0642] (0.0174 [0.0384])			0.2 [0.4]	1.6 [3.5]	1.9 [4.2]
160 [6.299]	24.9 [54.9] (22.4 [49.4])	27.8 [61.3] (25.3 [55.8])	30.7 [67.7] (28.2 [62.2])	31.9 [70.3] (29.4 [64.8])	31.1 [68.6] (28.6 [63.1])	31.7 [69.9] (29.2 [64.4])	0.0352 [0.0776] (0.0210 [0.0459])			0.3 [0.7]	2.1 [4.6]	2.8 [6.2]
180 [7.087]	32.6 [71.9]	37.0 [81.6]	41.8 [92.2]	44.2 [97.5]	42.6 [93.9]	40.9 [90.2]	0.0495 [0.1091]	—	—	0.4 [0.9]	3.9 [8.6]	3.9 [8.6]
200 [7.874]	40.9 [90.2]	45.7 [100.8]	51.7 [114.0]	53.1 [117.1]	52.9 [116.6]	52.5 [115.8]	0.0573 [0.1263]	—	—	0.6 [1.3]	3.7 [8.2]	4.0 [8.8]

Remark: Figures in parentheses () are for cylinders with magnets. Calculation example : For cylinder with magnet, foot mounting type, with bore size of 140mm, stroke of 100mm, and two **ZC130A** sensor switches,

Note: For lead wire length A (1000mm [39in.]).

$18.4 + (0.0174 \times 100) + 0.07 \times 2 = 20.28\text{kg} [44.72\text{lb.}]$

Dimensions of Basic Type (mm)

KA0SD Bore size × Stroke

SD Bore size

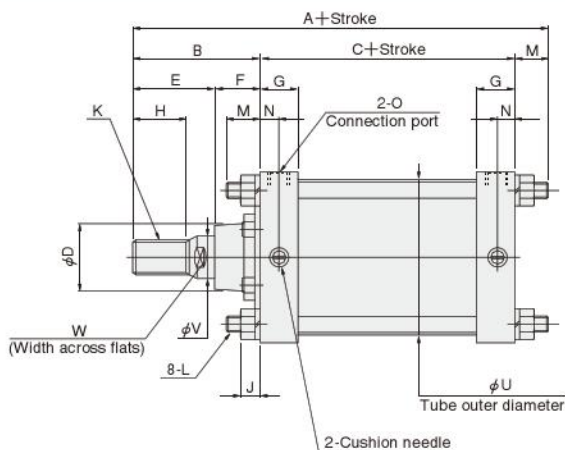
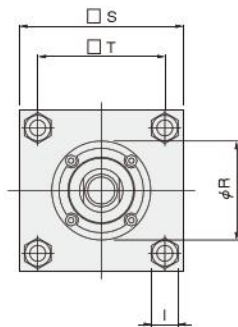

Bore mm [in.]	Code	A	B	C	D	E	F	G	H	I	J	K
125 [4.921]		235	110	98	60	72	38	35	50	22	14.5	M30×1.5
140 [5.512]		235	110	98	60	72	38	35	50	22	14.5	M30×1.5
160 [6.299]		256.5	120	106	60	82	38	39	56	24	17	M36×1.5
180 [7.087]		281	135	111	70	95	40	39	63	27	19.6	M40×1.5
200 [7.874]		281	135	111	70	95	40	39	63	30	21.1	M45×1.5

Bore mm [in.]	Code	L	M	N	O	R	S	T	U	V	W
125 [4.921]		M14×1.5	27	16	Rc1/2	90 ^{-0.1} _{-0.2}	145	115	134(135)	35	32
140 [5.512]		M14×1.5	27	16	Rc1/2	90 ^{-0.1} _{-0.2}	160	128	150	35	32
160 [6.299]		M16×1.5	30.5	18.5	Rc3/4	90 ^{-0.1} _{-0.2}	182	144	170	40	36
180 [7.087]		M18×1.5	35	18.5	Rc3/4	115 ^{-0.1} _{-0.2}	204	162	193	45	41
200 [7.874]		M20×1.5	35	18.5	Rc3/4	115 ^{-0.1} _{-0.2}	226	182	213	50	46

Figures in parentheses () are for cylinders with magnets.

Dimensions of Foot Mounting Type (mm)

KA1SD Bore size × Stroke

Foot mounting bracket only
 φ 125, φ 140 :SD-F01
 φ 160, φ 180 :SD-F02
 φ 200 :SD-F03

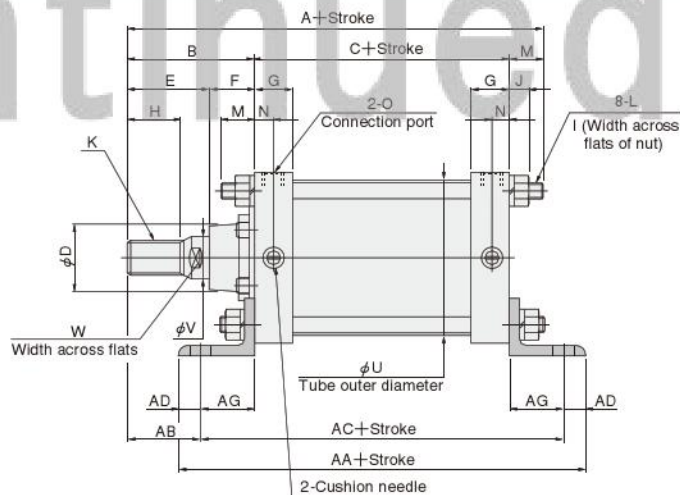
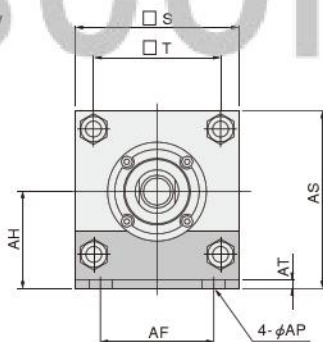

Bore mm [in.]	Code	A	B	C	D	E	F	G	H	I	J	K	L	M	N	O
125 [4.921]		235	110	98	60	72	38	35	50	22	14.5	M30×1.5	M14×1.5	27	16	Rc1/2
140 [5.512]		235	110	98	60	72	38	35	50	22	14.5	M30×1.5	M14×1.5	27	16	Rc1/2
160 [6.299]		256.5	120	106	60	82	38	39	56	24	17	M36×1.5	M16×1.5	30.5	18.5	Rc3/4
180 [7.087]		281	135	111	70	95	40	39	63	27	19.6	M40×1.5	M18×1.5	35	18.5	Rc3/4
200 [7.874]		281	135	111	70	95	40	39	63	30	21.1	M45×1.5	M20×1.5	35	18.5	Rc3/4

Bore mm [in.]	Code	S	T	U	V	W	AA	AB	AC	AD	AF	AG	AH	AP	AS	AT
125 [4.921]		145	115	134(135)	35	32	228	65	188	20	100	45	85	19	157.5	8
140 [5.512]		160	128	150	35	32	248	65	188	30	112	45	100	19	180	9
160 [6.299]		182	144	170	40	36	256	70	206	25	118	50	106	19	197	9
180 [7.087]		204	162	193	45	41	291	75	231	30	132	60	125	24	227	10
200 [7.874]		226	182	213	50	46	291	75	231	30	150	60	132	24	245	10

Figures in parentheses () are for cylinders with magnets.

Dimensions of Rod Side Flange Mounting Type (mm)

KA3SD Bore size X Stroke

 Flange mounting bracket only
 φ 125, φ 140 :SD-RFR1
 φ 160, φ 180 :SD-RFR2
 φ 200 :SD-RFR3

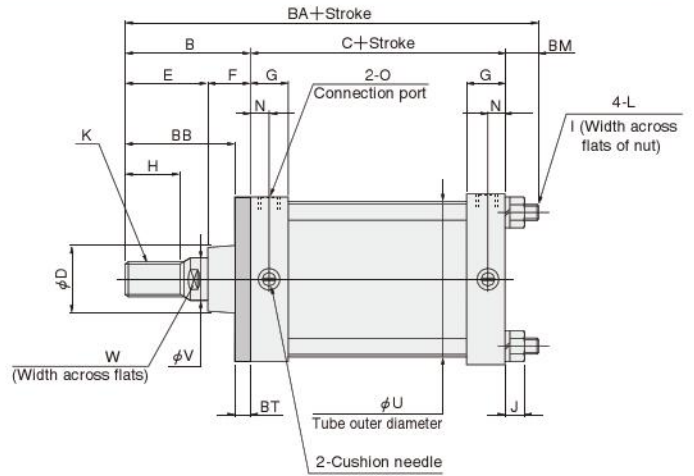
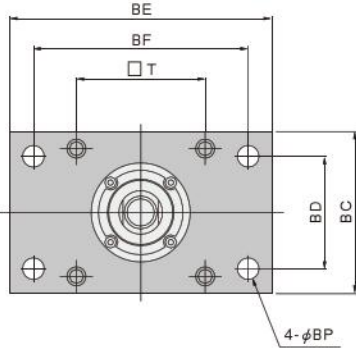

Bore max [in.]	Code	B	C	D	E	F	G	H	I	J	K	L	N
125 [4.921]		110	98	60	72	38	35	50	22	14.5	M30×1.5	M14×1.5	16
140 [5.512]		110	98	60	72	38	35	50	22	14.5	M30×1.5	M14×1.5	16
160 [6.299]		120	106	60	82	38	39	56	24	17	M36×1.5	M16×1.5	18.5
180 [7.087]		135	111	70	95	40	39	63	27	19.6	M40×1.5	M18×1.5	18.5
200 [7.874]		135	111	70	95	40	39	63	30	21.1	M45×1.5	M20×1.5	18.5

Bore max [in.]	Code	O	T	U	V	W	BA	BB	BC	BD	BE	BF	BM	BP	BT
125 [4.921]		Rc1/2	115	134(135)	35	32	231	96	145	100	230	190	23	19	14
140 [5.512]		Rc1/2	128	150	35	32	225	90	160	112	255	212	17	19	20
160 [6.299]		Rc3/4	144	170	40	36	246	100	182	118	275	236	20	19	20
180 [7.087]		Rc3/4	162	193	45	41	269	110	204	132	320	265	23	24	25
200 [7.874]		Rc3/4	182	213	50	46	271	110	226	150	335	280	25	24	25

Figures in parentheses () are for cylinders with magnets.

Dimensions of Head Side Flange Mounting Type (mm)

KA5SD Bore size X Stroke

 Flange mounting bracket only
 φ 125, φ 140 :SD-HFR1
 φ 160, φ 180 :SD-HFR2
 φ 200 :SD-HFR3

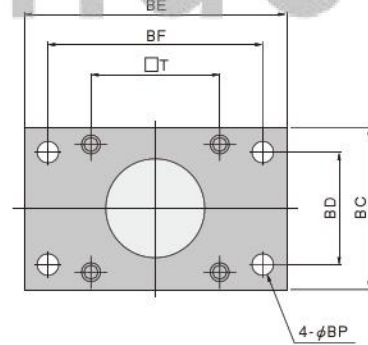
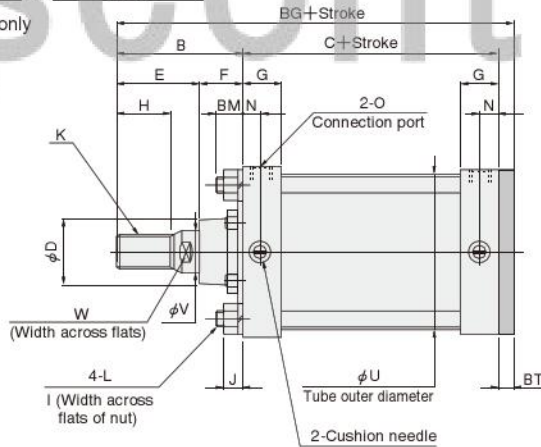

Bore max [in.]	Code	B	C	D	E	F	G	H	I	J	K	L	N
125 [4.921]		110	98	60	72	38	35	50	22	14.5	M30×1.5	M14×1.5	16
140 [5.512]		110	98	60	72	38	35	50	22	14.5	M30×1.5	M14×1.5	16
160 [6.299]		120	106	60	82	38	39	56	24	17	M36×1.5	M16×1.5	18.5
180 [7.087]		135	111	70	95	40	39	63	27	19.6	M40×1.5	M18×1.5	18.5
200 [7.874]		135	111	70	95	40	39	63	30	21.1	M45×1.5	M20×1.5	18.5

Bore max [in.]	Code	O	T	U	V	W	BC	BD	BE	BF	BG	BM	BP	BT
125 [4.921]		Rc1/2	115	134(135)	35	32	145	100	230	190	222	23	19	14
140 [5.512]		Rc1/2	128	150	35	32	160	112	255	212	228	17	19	20
160 [6.299]		Rc3/4	144	170	40	36	182	118	275	236	246	20	19	20
180 [7.087]		Rc3/4	162	193	45	41	204	132	320	265	271	23	24	25
200 [7.874]		Rc3/4	182	213	50	46	226	150	335	280	271	25	24	25

Figures in parentheses () are for cylinders with magnets.

Dimensions of Clevis Mounting Type (mm)

KA7SD Bore size × Stroke



Clevis mounting bracket only
 φ 125, φ 140 :SD-CL1
 φ 160, φ 180 :SD-CL2
 φ 200 :SD-CL3

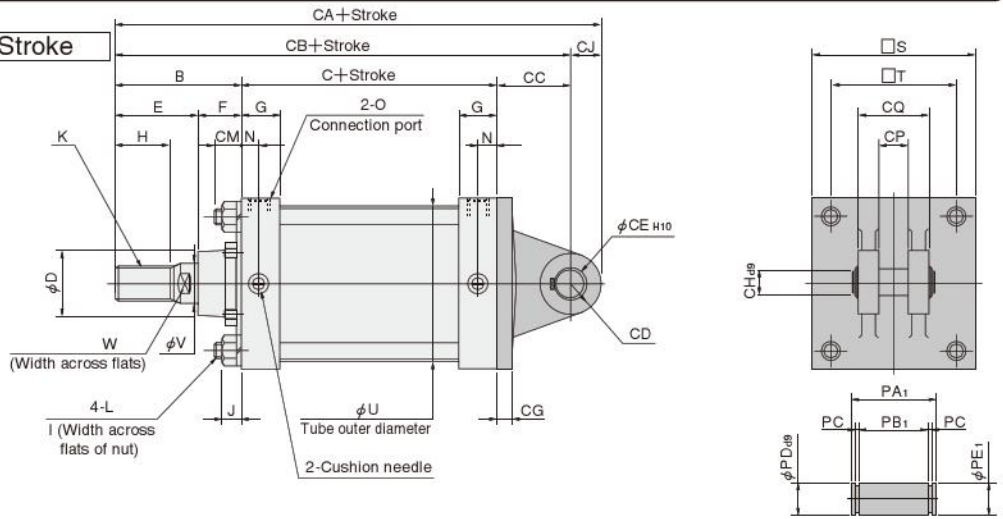

Bore mm [in.]	Code	B	C	D	E	F	G	H	I	J	K	L	N	O	S	T	U	V
125 [4.921]		110	98	60	72	38	35	50	22	14.5	M30×1.5	M14×1.5	16	Rc1/2	145	115	134	35
140 [5.512]		110	98	60	72	38	35	50	22	14.5	M30×1.5	M14×1.5	16	Rc1/2	160	128	150	35
160 [6.299]		120	106	60	82	38	39	56	24	17	M36×1.5	M16×1.5	18.5	Rc3/4	182	144	170	40
180 [7.087]		135	111	70	95	40	39	63	27	19.6	M40×1.5	M18×1.5	18.5	Rc3/4	204	162	193	45
200 [7.874]		135	111	70	95	40	39	63	30	21.1	M45×1.5	M20×1.5	18.5	Rc3/4	226	182	213	50

Bore mm [in.]	Code	W	CA	CB	CC	CD	CE	CG	CH	CJ	CM	CP	CQ	PA ₁	PB ₁	PC	PD	PE ₁
125 [4.921]		32	301	273	65	R28	25 ^{+0.084} ₀	18	25 ^{-0.065} _{-0.117}	28	19	32 ^{+0.4} _{+0.1}	64 ^{-0.1} _{-0.4}	73	65 ±0.5	1.35 ^{+0.14} ₀	25 ^{-0.065} _{-0.117}	23.9 ⁰ _{-0.21}
140 [5.512]		32	315	283	75	R32	28 ^{+0.084} ₀	20	28 ^{-0.065} _{-0.117}	32	17	36 ^{+0.4} _{+0.1}	72 ^{-0.1} _{-0.4}	82	73 ±0.5	1.65 ^{+0.14} ₀	28 ^{-0.065} _{-0.117}	26.6 ⁰ _{-0.21}
160 [6.299]		36	342	306	80	R36	32 ^{+0.100} ₀	20	32 ^{-0.080} _{-0.142}	36	20	40 ^{+0.4} _{+0.1}	80 ^{-0.1} _{-0.4}	90	81 ±0.5	1.65 ^{+0.14} ₀	32 ^{-0.080} _{-0.142}	30.3 ⁰ _{-0.25}
180 [7.087]		41	379	336	90	R43	40 ^{+0.100} ₀	25	40 ^{-0.080} _{-0.142}	43	23	50 ^{+0.4} _{+0.1}	100 ^{-0.1} _{-0.4}	113	101.5 ±0.5	1.9 ^{+0.14} ₀	40 ^{-0.080} _{-0.142}	38 ⁰ _{-0.25}
200 [7.874]		46	381	336	90	R45	40 ^{+0.100} ₀	25	40 ^{-0.080} _{-0.142}	45	25	50 ^{+0.4} _{+0.1}	100 ^{-0.1} _{-0.4}	113	101.5 ±0.5	1.9 ^{+0.14} ₀	40 ^{-0.080} _{-0.142}	38 ⁰ _{-0.25}

Dimensions of Pivot Mounting Type (mm)

KA8SD Bore size × Stroke



Pivot mounting bracket only
 φ 125, φ 140 :SD-ITY1
 φ 160, φ 180 :SD-ITY2
 φ 200 :SD-ITY3

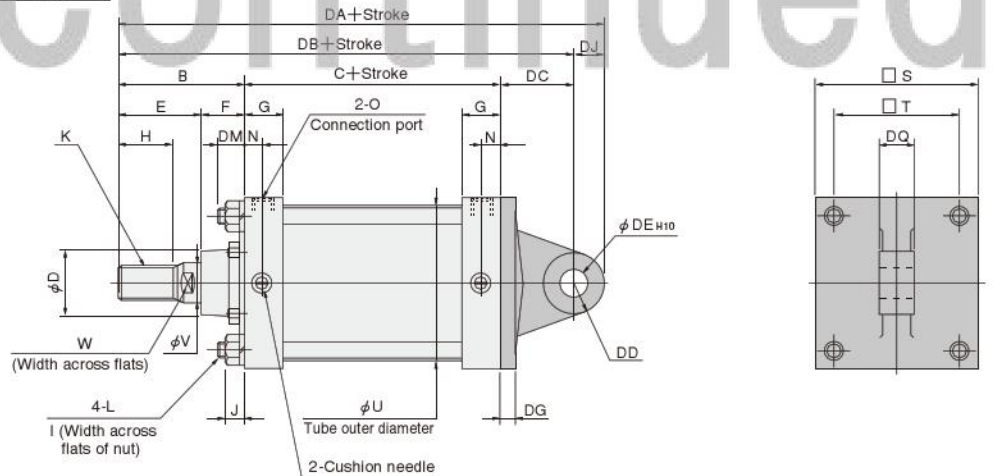

Bore mm [in.]	Code	B	C	D	E	F	G	H	I	J	K	L	N	O
125 [4.921]		110	98	60	72	38	35	50	22	14.5	M30×1.5	M14×1.5	16	Rc1/2
140 [5.512]		110	98	60	72	38	35	50	22	14.5	M30×1.5	M14×1.5	16	Rc1/2
160 [6.299]		120	106	60	82	38	39	56	24	17	M36×1.5	M16×1.5	18.5	Rc3/4
180 [7.087]		135	111	70	95	40	39	63	27	19.6	M40×1.5	M18×1.5	18.5	Rc3/4
200 [7.874]		135	111	70	95	40	39	63	30	21.1	M45×1.5	M20×1.5	18.5	Rc3/4

Bore mm [in.]	Code	S	T	U	V	W	DA	DB	DC	DD	DE	DG	DJ	DM	DQ
125 [4.921]		145	115	134	35	32	301	273	65	R28	25 ^{+0.084} ₀	18	28	19	32 ^{-0.1} _{-0.4}
140 [5.512]		160	128	150	35	32	315	283	75	R32	28 ^{+0.084} ₀	20	32	17	36 ^{-0.1} _{-0.4}
160 [6.299]		182	144	170	40	36	342	306	80	R36	32 ^{+0.100} ₀	20	36	20	40 ^{-0.1} _{-0.4}
180 [7.087]		204	162	193	45	41	379	336	90	R43	40 ^{+0.100} ₀	25	43	23	50 ^{-0.1} _{-0.4}
200 [7.874]		226	182	213	50	46	381	336	90	R45	40 ^{+0.100} ₀	25	45	25	50 ^{-0.1} _{-0.4}

Dimensions of Trunnion Mounting Type (mm)

KA11SD Bore size X Stroke

- CAD** Trunnion mounting bracket only
 φ 125, φ 140 :SD-TR1
 φ 160, φ 180 :SD-TR2
 φ 200 :SD-TR3

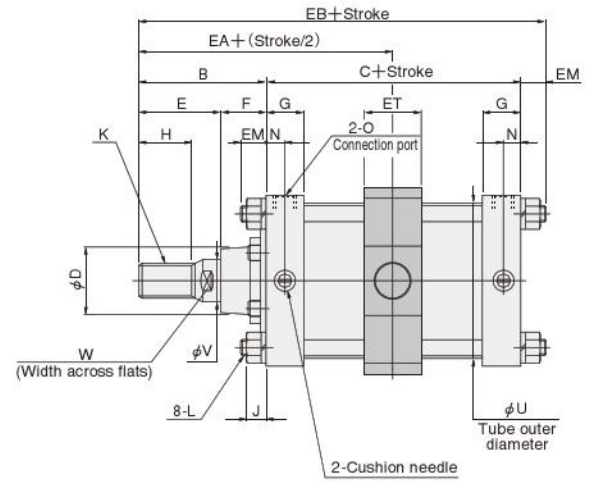
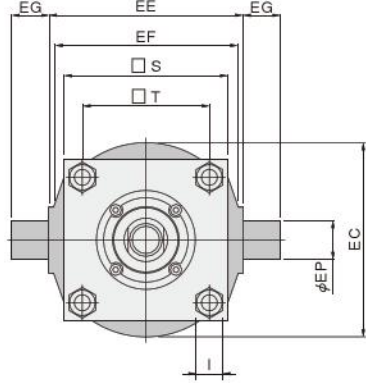

Bore mm [in.]	Code	B	C	D	E	F	G	H	I	J	K	L	N	O
125 [4.921]		110	98	60	72	38	35	50	22	14.5	M30×1.5	M14×1.5	16	Rc1/2
140 [5.512]		110	98	60	72	38	35	50	22	14.5	M30×1.5	M14×1.5	16	Rc1/2
160 [6.299]		120	106	60	82	38	39	56	24	17	M36×1.5	M16×1.5	18.5	Rc3/4
180 [7.087]		135	111	70	95	40	39	63	27	19.6	M40×1.5	M18×1.5	18.5	Rc3/4
200 [7.874]		135	111	70	95	40	39	63	30	21.1	M45×1.5	M20×1.5	18.5	Rc3/4

Bore mm [in.]	Code	S	T	U	V	W	EA	EB	EC	EE	EF	EG	EM	EP	ET
125 [4.921]		145	115	134(135)	35	32	159	226	164	170 ^{-0.1} _{-0.4}	160	32	18	32 ^{-0.050} _{-0.089}	50
140 [5.512]		160	128	150	35	32	159	226	184	190 ^{-0.1} _{-0.4}	180	36	18	36 ^{-0.050} _{-0.089}	55
160 [6.299]		182	144	170	40	36	173	245.5	208	212 ^{-0.1} _{-0.4}	200	40	19.5	40 ^{-0.050} _{-0.089}	60
180 [7.087]		204	162	193	45	41	190.5	269.5	225	236 ^{-0.1} _{-0.6}	225	45	23.5	45 ^{-0.050} _{-0.089}	62
200 [7.874]		226	182	213	50	46	190.5	270.5	255	265 ^{-0.1} _{-0.6}	255	45	24.5	45 ^{-0.050} _{-0.089}	67

Figures in parentheses () are for cylinders with magnets.

Discontinued

SD HEAVY DUTY ROD CYLINDERS



Symbol

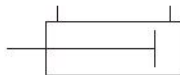

Specifications

Item	Bore size mm [in.]	125	140	160	180	200
		[4.921]	[5.512]	[6.299]	[7.087]	[7.874]
Operation type		Double acting type				
Media		Air				
Mounting type		Basic type, Foot type, Rod side flange type, Head side flange type, Clevis type, Pivot type, Trunnion type				
Operating pressure range MPa [psi.]		0.05~0.97 [7~141]				
Proof pressure MPa [psi.]		1.47 [213]				
Operating temperature range °C [°F]		0~60 [32~140]				
Operating speed range mm/s [in./sec.]		30~500 [1.2~19.7]				
Cushion stroke mm [in.]		26 [1.024]		28 [1.102]		
Lubrication		Not required				
Port size	Rc	1/2		3/4		

Caution Cylinder with magnet is not available for the SD heavy duty rod cylinders.

Bore Size and Stroke

Standard cylinder	Bore size	Standard strokes	Maximum available stroke
	mm		
Standard cylinder	125	0~1000	1000
	140		
	160		
	180		
	200	0~990	990

Remark: Minimum available stroke of trunnion mounting type is ϕ 125: 22mm, ϕ 140: 27mm, ϕ 160: 32mm, ϕ 180: 29mm, and ϕ 200: 34mm.

The strokes listed below or larger should be included with class 2 pressure vessels. mm

Bore size	Cylinder stroke
125	3640
140	2615
160	1990
180	1573
200	1000

Order Codes

KA SD Z 125×100 - -

Bore size
×
Stroke

Cylinder specification

Z — Heavy duty rod cylinder

Mounting type

- 0 — Basic type
- 1 — Foot mounting type
- 3 — Rod side flange mounting type
- 5 — Head side flange mounting type
- 7 — Clevis mounting type (with pin)
- 8 — Pivot mounting type
- 11 — Trunnion mounting type

Rod end accessory

- Blank — No rod end accessory
- Y — With Y type knuckle (with pin)
- I — With I type knuckle

Rod end nut

- Blank — No nut
- N1 — With 1 nut
- N2 — With 2 nuts

Discontinued

Inner Construction and Major Parts

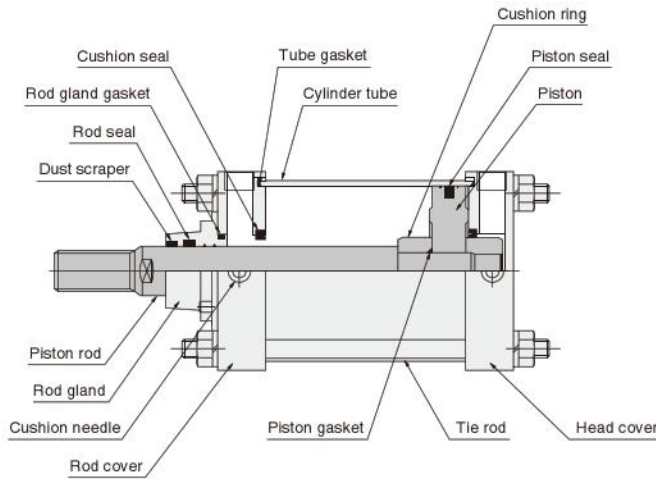

● Cushion

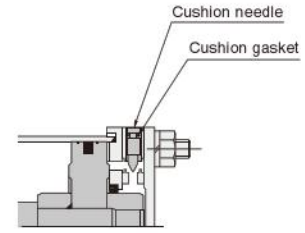

Major Parts and Materials

Parts	Bore size mm	125	140	160	180	200
Cylinder tube		Steel pipe (inside: hard chrome plated, outside: silver metallic painted)				
Piston		Cast iron				
Piston rod		Steel (hard chrome plated)				
Cushion ring		Mild steel (zinc plated)				
Rod cover		Mild steel (black oxide)				
Head cover						
Tie rod		Mild steel (zinc plated)				
Rod gland		Aluminum alloy (hard anodized)	Cast iron (painted)			
Seal		Synthetic rubber (NBR)				

Parts	Bore size mm	125	140	160	180	200
Foot mounting bracket		Mild steel (painted)				
Flange mounting bracket		Cast iron (manganese treated)				
Clevis mounting bracket						
Pivot mounting bracket						
Trunnion mounting bracket		Cast iron (manganese treated)				
Bellows		Nylon tarpaulin				
I type knuckle		Steel (alkali coloring)				
Y type knuckle		Cast iron (manganese treated)				Mild steel (alkali coloring)
Pin		Steel (zinc plated)				

Seals

Item	Dust scraper	Rod seal	Rod gland gasket	Cylinder tube gasket	Cushion seal	Piston seal	Piston gasket	Cushion gasket	
Bore size mm	Quantity	1	1	1	2	2	1	1	2
125		SDR-40	PNY-40	G-50	S-120	PCS-50	PWP-125N	G-25	P-7
140		SDR-40	PNY-40	G-50	S-135	PCS-50	PWP-140N	G-25	P-7
160		SDR-45	PNY-45	G-60	#160	PCS-50	PWP-160N	G-25	P-7
180		SDR-50	PNY-50	G-60	#180	PCS-60	PSD-180	G-35	P-7
200		SDR-60	PNY-60	G-70	#200	PCS-60,65 ^{Note}	PSD-200	G-35	P-7

Note: One PCS-65 on the rod side, and one PCS-60 on the head side.

Remark: For SD heavy duty rod cylinder seal repair kits, consult us.

Mass

Bore size mm [in.]	Zero stroke mass						Additional mass for each 1mm [0.0394in.] stroke	Additional mass		
	Basic type	Foot mounting type	Flange mounting type	Clevis mounting type (With pin)	Pivot mounting type	Trunnion mounting type		Nut	Y type knuckle (With pin)	I type knuckle
125 [4.921]	15.1 [33.3]	16.8 [37.0]	17.6 [38.8]	19.0 [41.9]	18.6 [41.0]	18.5 [40.8]	0.0279 [0.0615]	0.3 [0.7]	2.1 [4.6]	2.8 [6.2]
140 [5.512]	18.1 [39.9]	20.7 [45.6]	22.7 [50.1]	23.3 [51.4]	22.9 [50.5]	22.6 [49.8]	0.0314 [0.0692]	0.3 [0.7]	2.1 [4.6]	2.8 [6.2]
160 [6.299]	25.4 [56.0]	28.3 [62.4]	31.2 [68.8]	32.4 [71.4]	31.6 [69.7]	32.2 [71.0]	0.0378 [0.0833]	0.4 [0.9]	3.9 [8.6]	3.9 [8.6]
180 [7.087]	33.0 [72.8]	37.4 [82.5]	42.2 [93.1]	44.6 [98.3]	43.0 [94.8]	41.3 [91.1]	0.0524 [0.1155]	0.6 [1.3]	3.7 [8.2]	4.0 [8.8]
200 [7.874]	44.9 [99.0]	49.7 [109.6]	55.9 [123.3]	57.1 [125.9]	56.9 [125.5]	56.5 [124.6]	0.0641 [0.1413]	1.0 [2.2]	7.8 [17.2]	4.0 [8.8]

Calculation example: For standard cylinder, foot mounting type, with bore size of 140mm and stroke of 100mm, $20.7 + (0.0314 \times 100) = 23.84\text{kg}$ [52.57lb.]

Dimensions of Basic Type (mm)

KA0SDZ Bore size × Stroke



SDZ Bore size

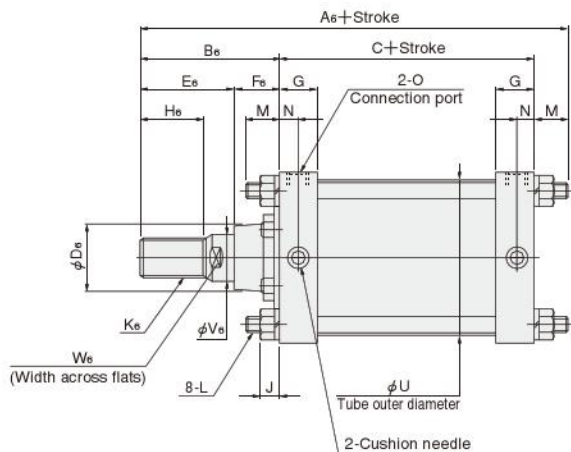
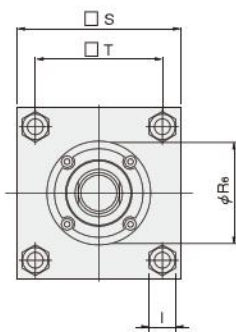

Bore size [in.]	Code	A _e	B _e	C	D _e	E _e	F _e	G	H _e	I	J	K _e
125	[4.921]	245	120	98	60	82	38	35	56	22	14.5	M36×1.5
140	[5.512]	245	120	98	60	82	38	35	56	22	14.5	M36×1.5
160	[6.299]	271.5	135	106	70	95	40	39	63	24	17	M40×1.5
180	[7.087]	281	135	111	70	95	40	39	63	27	19.6	M45×1.5
200	[7.874]	291	145	111	123	105	40	39	71	30	21.1	M56×2

Bore size [in.]	Code	L	M	N	O	R _e	S	T	U	V _e	W _e
125	[4.921]	M14×1.5	27	16	Rc1/2	90 ^{-0.1} _{-0.2}	145	115	134	40	36
140	[5.512]	M14×1.5	27	16	Rc1/2	90 ^{-0.1} _{-0.2}	160	128	150	40	36
160	[6.299]	M16×1.5	30.5	18.5	Rc3/4	115 ^{-0.1} _{-0.2}	182	144	170	45	41
180	[7.087]	M18×1.5	35	18.5	Rc3/4	115 ^{-0.1} _{-0.2}	204	162	193	50	46
200	[7.874]	M20×1.5	35	18.5	Rc3/4	123 ^{-0.1} _{-0.2}	226	182	213	60	56

Dimensions of Foot Mounting Type (mm)

KA1SDZ Bore size × Stroke



Foot mounting bracket only
 φ 125, φ 140 : SD-F01
 φ 160, φ 180 : SD-F02
 φ 200 : SD-F03

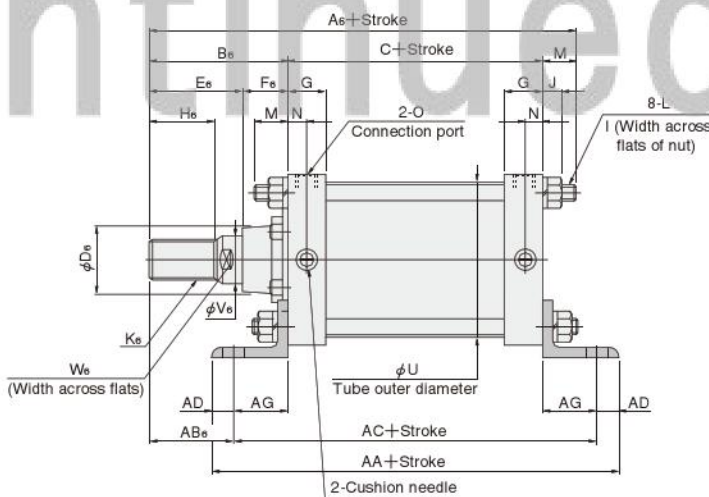
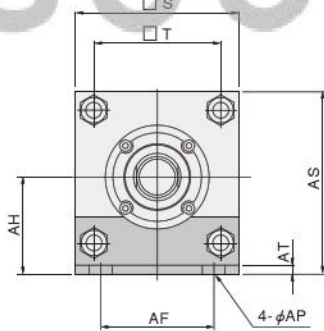

Bore size [in.]	Code	A _e	B _e	C	D _e	E _e	F _e	G	H _e	I	J	K _e	L	M	N	O
125	[4.921]	245	120	98	60	82	38	35	56	22	14.5	M36×1.5	M14×1.5	27	16	Rc1/2
140	[5.512]	245	120	98	60	82	38	35	56	22	14.5	M36×1.5	M14×1.5	27	16	Rc1/2
160	[6.299]	271.5	135	106	70	95	40	39	63	24	17	M40×1.5	M16×1.5	30.5	18.5	Rc3/4
180	[7.087]	281	135	111	70	95	40	39	63	27	19.6	M45×1.5	M18×1.5	35	18.5	Rc3/4
200	[7.874]	291	145	111	123	105	40	39	71	30	21.1	M56×2	M20×1.5	35	18.5	Rc3/4

Bore size [in.]	Code	S	T	U	V _e	W _e	AA	AB _e	AC	AD	AF	AG	AH	AP	AS	AT
125	[4.921]	145	115	134	40	36	228	75	188	20	100	45	85	19	157.5	8
140	[5.512]	160	128	150	40	36	248	75	188	30	112	45	100	19	180	9
160	[6.299]	182	144	170	45	41	256	85	206	25	118	50	108	19	197	9
180	[7.087]	204	162	193	50	46	291	75	231	30	132	60	125	24	227	10
200	[7.874]	226	182	213	60	56	291	85	231	30	150	60	132	24	245	10

Dimensions of Rod Side Flange Mounting Type (mm)

KA3SDZ Bore size × Stroke

Flange mounting bracket only
 φ 125, φ 140 :SD-RFR1
 φ 160, φ 180 :SD-RFR2
 φ 200 :SD-RFR3

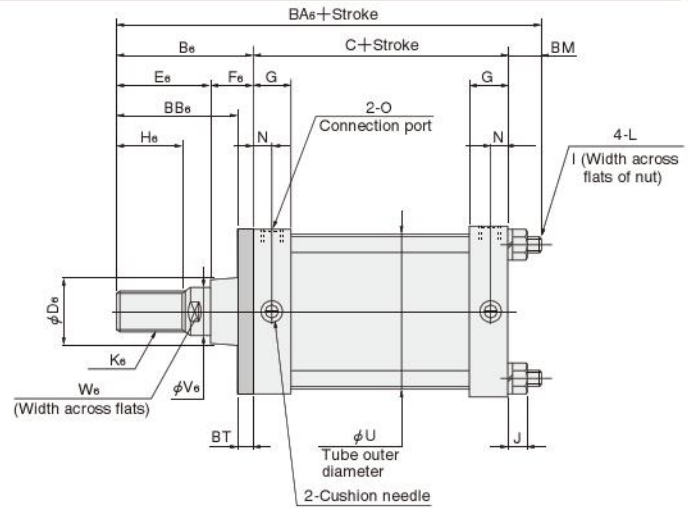
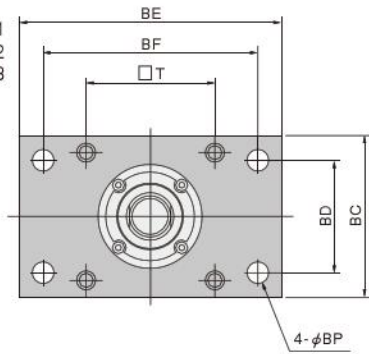

Bore mm [in.]	Code	B _e	C	D _e	E _e	F _e	G	H _e	I	J	K _e	L	N
125 [4.921]		120	98	60	82	38	35	56	22	14.5	M36×1.5	M14×1.5	16
140 [5.512]		120	98	60	82	38	35	56	22	14.5	M36×1.5	M14×1.5	16
160 [6.299]		135	106	70	95	40	39	63	24	17	M40×1.5	M16×1.5	18.5
180 [7.087]		135	111	70	95	40	39	63	27	19.6	M45×1.5	M18×1.5	18.5
200 [7.874]		145	111	123	105	40	39	71	30	21.1	M56×2	M20×1.5	18.5

Bore mm [in.]	Code	O	T	U	V _e	W _e	BA _e	BB _e	BC	BD	BE	BF	BM	BP	BT
125 [4.921]		Rc1/2	115	134	40	36	241	106	145	100	230	190	23	19	14
140 [5.512]		Rc1/2	128	150	40	36	235	100	160	112	255	212	17	19	20
160 [6.299]		Rc3/4	144	170	45	41	261	115	182	118	275	236	20	19	20
180 [7.087]		Rc3/4	162	193	50	46	269	110	204	132	320	265	23	24	25
200 [7.874]		Rc3/4	182	213	60	56	281	120	226	150	335	280	25	24	25

Dimensions of Head Side Flange Mounting Type (mm)

KA5SDZ Bore size × Stroke

Flange mounting bracket only
 φ 125, φ 140 :SD-HFR1
 φ 160, φ 180 :SD-HFR2
 φ 200 :SD-HFR3

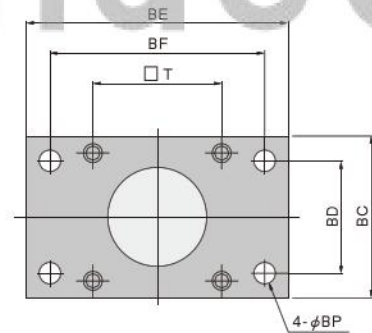
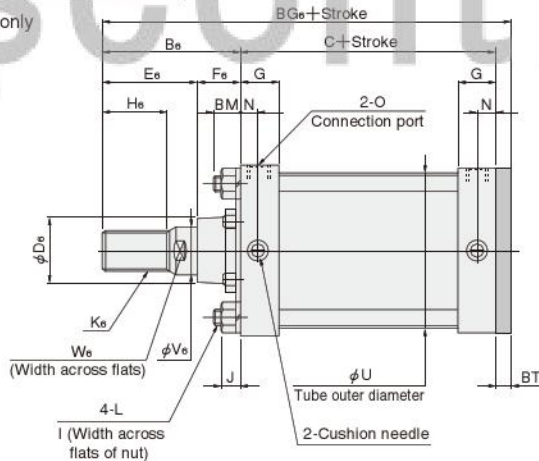

Bore mm [in.]	Code	B _e	C	D _e	E _e	F _e	G	H _e	I	J	K _e	L	N
125 [4.921]		120	98	60	82	38	35	56	22	14.5	M36×1.5	M14×1.5	16
140 [5.512]		120	98	60	82	38	35	56	22	14.5	M36×1.5	M14×1.5	16
160 [6.299]		135	106	70	95	40	39	63	24	17	M40×1.5	M16×1.5	18.5
180 [7.087]		135	111	70	95	40	39	63	27	19.6	M45×1.5	M18×1.5	18.5
200 [7.874]		145	111	123	105	40	39	71	30	21.1	M56×2	M20×1.5	18.5

Bore mm [in.]	Code	O	T	U	V _e	W _e	BC	BD	BE	BF	BG _e	BM	BP	BT
125 [4.921]		Rc1/2	115	134	40	36	145	100	230	190	232	23	19	14
140 [5.512]		Rc1/2	128	150	40	36	160	112	255	212	238	17	19	20
160 [6.299]		Rc3/4	144	170	45	41	182	118	275	236	261	20	19	20
180 [7.087]		Rc3/4	162	193	50	46	204	132	320	265	271	23	24	25
200 [7.874]		Rc3/4	182	213	60	56	226	150	335	280	281	25	24	25

Dimensions of Clevis Mounting Type (mm)

KA7SDZ Bore size × Stroke

-  Clevis mounting bracket only
 φ 125, φ 140 : SD-CL1
 φ 160, φ 180 : SD-CL2
 φ 200 : SD-CL3

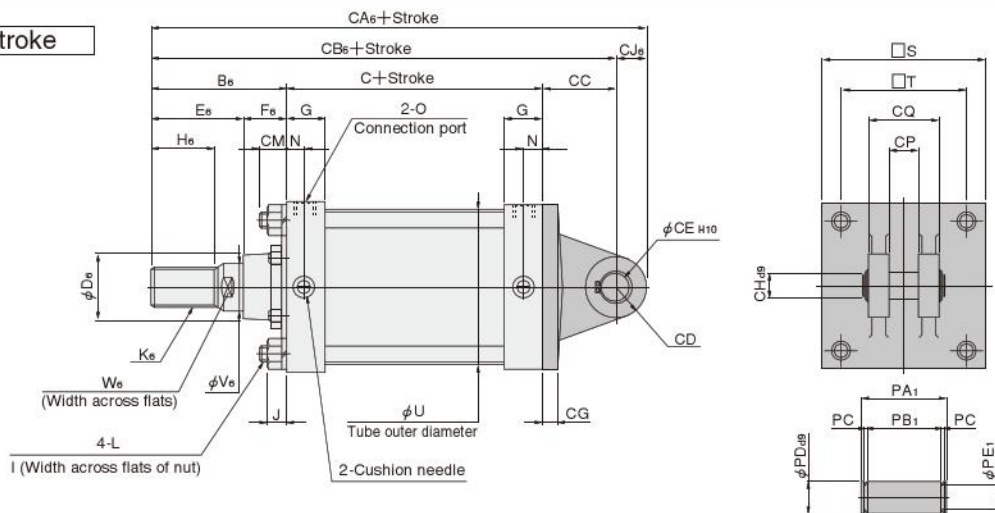

Bore mm [in.]	Code	B ₆	C	D ₆	E ₆	F ₆	G	H ₆	I	J	K ₆	L	N	O	S	T	U
125 [4.921]		120	98	60	82	38	35	56	22	14.5	M36×1.5	M14×1.5	16	Rc1/2	145	115	134
140 [5.512]		120	98	60	82	38	35	56	22	14.5	M36×1.5	M14×1.5	16	Rc1/2	160	128	150
160 [6.299]		135	106	70	95	40	39	63	24	17	M40×1.5	M16×1.5	18.5	Rc3/4	182	144	170
180 [7.087]		135	111	70	95	40	39	63	27	19.6	M45×1.5	M18×1.5	18.5	Rc3/4	204	162	193
200 [7.874]		145	111	123	105	40	39	71	30	21.1	M56×1.5	M20×1.5	18.5	Rc3/4	226	182	213

Bore mm [in.]	Code	V ₆	W ₆	CA ₆	CB ₆	CC	CD	CE	CG	CH	CJ ₆	CM	CP	CQ	PA ₁	PB ₁	PC	PD	PE ₁
125 [4.921]		40	36	311	283	65	R28	25 ^{+0.084} ₀	18	25 ^{-0.065} _{-0.117}	28	19	32 ^{+0.4} _{+0.1}	64 ^{-0.1} _{-0.4}	73	65 ±0.5	1.35 ^{+0.14} ₀	25 ^{-0.065} _{-0.117}	23.9 ⁰ _{-0.21}
140 [5.512]		40	36	325	293	75	R32	28 ^{+0.084} ₀	20	28 ^{-0.065} _{-0.117}	32	17	36 ^{+0.4} _{+0.1}	72 ^{-0.1} _{-0.4}	82	73 ±0.5	1.65 ^{+0.14} ₀	28 ^{-0.065} _{-0.117}	26.6 ⁰ _{-0.21}
160 [6.299]		45	41	357	321	80	R36	32 ^{+0.100} ₀	20	32 ^{-0.080} _{-0.142}	36	20	40 ^{+0.4} _{+0.1}	80 ^{-0.1} _{-0.4}	90	81 ±0.5	1.65 ^{+0.14} ₀	32 ^{-0.080} _{-0.142}	30.3 ⁰ _{-0.25}
180 [7.087]		50	46	379	336	90	R43	40 ^{+0.100} ₀	25	40 ^{-0.080} _{-0.142}	43	23	50 ^{+0.4} _{+0.1}	100 ^{-0.1} _{-0.4}	113	101.5 ±0.5	1.9 ^{+0.14} ₀	40 ^{-0.080} _{-0.142}	38 ⁰ _{-0.25}
200 [7.874]		60	56	391	346	90	R45	40 ^{+0.100} ₀	25	40 ^{-0.080} _{-0.142}	45	25	50 ^{+0.4} _{+0.1}	100 ^{-0.1} _{-0.4}	113	101.5 ±0.5	1.9 ^{+0.14} ₀	40 ^{-0.080} _{-0.142}	38 ⁰ _{-0.25}

Dimensions of Pivot Mounting Type (mm)

KA8SDZ Bore size × Stroke

-  Pivot mounting bracket only
 φ 125, φ 140 : SD-ITY1
 φ 160, φ 180 : SD-ITY2
 φ 200 : SD-ITY3

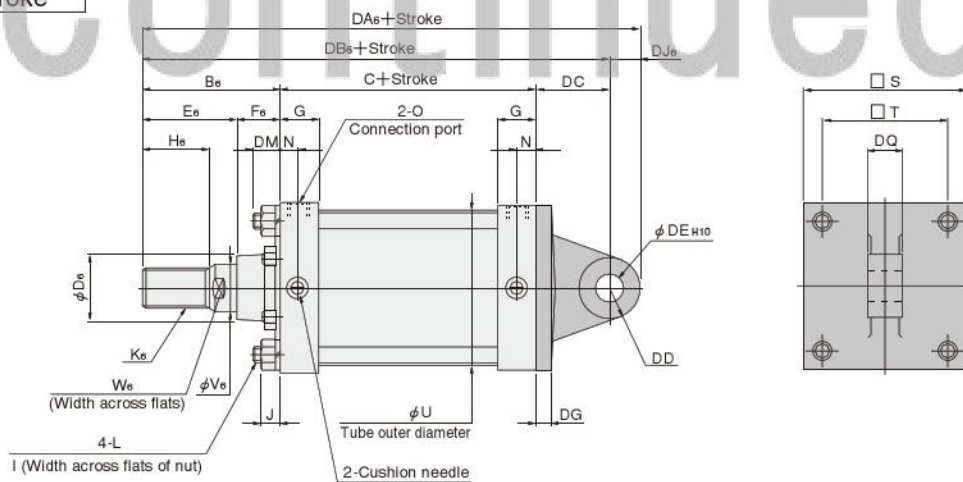

Bore mm [in.]	Code	B ₆	C	D ₆	E ₆	F ₆	G	H ₆	I	J	K ₆	L	N	O
125 [4.921]		120	98	60	82	38	35	56	22	14.5	M36×1.5	M14×1.5	16	Rc1/2
140 [5.512]		120	98	60	82	38	35	56	22	14.5	M36×1.5	M14×1.5	16	Rc1/2
160 [6.299]		135	106	70	95	40	39	63	24	17	M40×1.5	M16×1.5	18.5	Rc3/4
180 [7.087]		135	111	70	95	40	39	63	27	19.6	M45×1.5	M18×1.5	18.5	Rc3/4
200 [7.874]		145	111	123	105	40	39	71	30	21.1	M56×2	M20×1.5	18.5	Rc3/4

Bore mm [in.]	Code	S	T	U	V ₆	W ₆	DA ₆	DB ₆	DC	DD	DE	DG	DJ ₆	DM	DQ
125 [4.921]		145	115	134	40	36	311	283	65	R28	25 ^{+0.084} ₀	18	28	19	32 ^{-0.1} _{-0.4}
140 [5.512]		160	128	150	40	36	325	293	75	R32	28 ^{+0.084} ₀	20	32	17	36 ^{-0.1} _{-0.4}
160 [6.299]		182	144	170	45	41	357	321	80	R36	32 ^{+0.100} ₀	20	36	20	40 ^{-0.1} _{-0.4}
180 [7.087]		204	162	193	50	46	379	336	90	R43	40 ^{+0.100} ₀	25	43	23	50 ^{-0.1} _{-0.4}
200 [7.874]		226	182	213	60	56	391	346	90	R45	40 ^{+0.100} ₀	25	45	25	50 ^{-0.1} _{-0.4}

Dimensions of Trunnion Mounting Type (mm)

KA11SDZ Bore size X Stroke

 Trunnion mounting bracket only
 φ 125, φ 140 :SD-TR1
 φ 160, φ 180 :SD-TR2
 φ 200 :SD-TR3

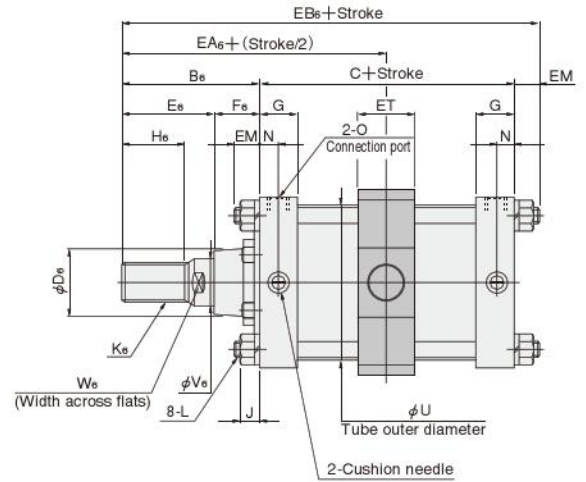
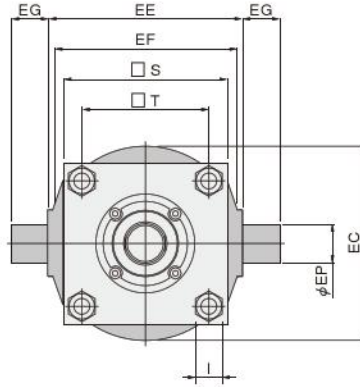

Bore size [in.]	Code	B ₆	C	D ₆	E ₆	F ₆	G	H ₆	I	J	K ₆	L	N	O
	125 [4.921]	120	98	60	82	38	35	56	22	14.5	M36×1.5	M14×1.5	16	Rc1/2
	140 [5.512]	120	98	60	82	38	35	56	22	14.5	M36×1.5	M14×1.5	16	Rc1/2
	160 [6.299]	135	106	70	95	40	39	63	24	17	M40×1.5	M16×1.5	18.5	Rc3/4
	180 [7.087]	135	111	70	95	40	39	63	27	19.6	M45×1.5	M18×1.5	18.5	Rc3/4
	200 [7.874]	145	111	123	105	40	39	71	30	21.1	M56×2	M20×1.5	18.5	Rc3/4

Bore size [in.]	Code	S	T	U	V ₆	W ₆	EA ₆	EB ₆	EC	EE	EF	EG	EM	EP	ET
	125 [4.921]	145	115	134	40	36	169	236	164	170 ^{-0.1} _{-0.4}	160	32	18	32 ^{-0.050} _{-0.089}	50
	140 [5.512]	160	128	150	40	36	169	236	184	190 ^{-0.1} _{-0.4}	180	36	18	36 ^{-0.050} _{-0.089}	55
	160 [6.299]	182	144	170	45	41	188	260.5	208	212 ^{-0.1} _{-0.4}	200	40	19.5	40 ^{-0.050} _{-0.089}	60
	180 [7.087]	204	162	193	50	46	190.5	269.5	225	236 ^{-0.1} _{-0.6}	225	45	23.5	45 ^{-0.050} _{-0.089}	62
	200 [7.874]	226	182	213	60	56	200.5	280.5	255	265 ^{-0.1} _{-0.6}	255	45	24.5	45 ^{-0.050} _{-0.089}	67

Discontinued

Inner Construction and Major Parts

● Cushion

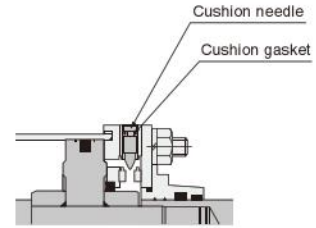
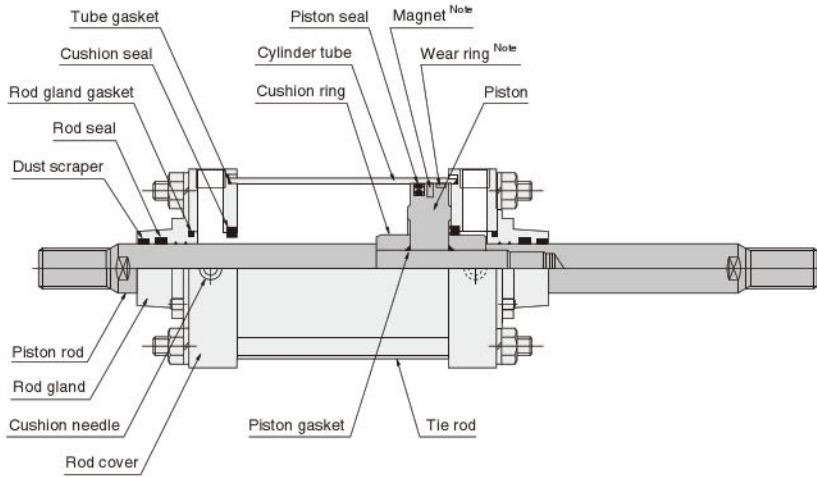

Note: For cylinder with magnet.

Major Parts and Materials

Parts	Bore size mm	125	140	160	180	200
Cylinder tube	Standard cylinder	Steel pipe (inside: hard chrome plated, outside: silver metallic painted)				
	Cylinder with magnet	Aluminum alloy (hard anodized)				
Piston		Cast iron ^{Note}				
Piston rod		Steel (hard chrome plated) (-RS : SUS)				
Cushion ring		Mild steel (zinc plated)				
Rod cover		Mild steel (black oxide)				
Tie rod		Mild steel (zinc plated)				
Rod gland		Aluminum alloy (hard anodized)				
Wear ring		Plastic				

Parts	Bore size mm	125	140	160	180	200
Magnet		Rubber magnet			—	
Seal		Synthetic rubber (NBR)				
Foot mounting bracket		Mild steel (painted)				
Flange mounting bracket		Cast iron (manganese treated)				
Trunnion mounting bracket		Cast iron (manganese treated)				
Bellows		Nylon tarpaulin				
I type knuckle		Mild steel (alkali coloring)				
Y type knuckle		Cast iron (manganese treated)				
Pin		Steel (zinc plated)				

Note : The cylinder with magnet is aluminum alloy.

Seals

Item	Dust scraper★	Rod seal★	Rod gland gasket	Cylinder tube gasket★	Cushion seal	Piston seal★	Piston gasket	Cushion gasket	
Bore size mm	Quantity	2	2	2	2	1	2	2	
125		SDR-35	PNY-35	G-50	S-120	PCS-50	PWP-125N	G-25	P-7
140		SDR-35	PNY-35	G-50	S-135	PCS-50	PWP-140N	G-25	P-7
160		SDR-40	PNY-40	G-50	#160	PCS-50	PWP-160N	G-25	P-7
180		SDR-45	PNY-45	G-60	#180	PCS-60	PSD-180	G-35	P-7
200		SDR-50	PNY-50	G-60	#200	PCS-60	PSD-200	G-35	P-7

Remark : Items marked with a star (★) are available as repair kits. The order code is the **SRK-NSD** [Bore size].

Note that the contents of a repair kit is 1 dust scraper, 1 rod seal, 1 piston seal, and 2 cylinder tube gaskets.

Note, however, that the repair kits with bore size of 125mm and 140mm cannot be used with SD cylinders manufactured prior to April 6, 2000 (because the piston rod diameters have been changed). For details, see p.543.

Mass

Bore size mm [in.]	Zero stroke mass					Additional mass for each 1mm [0.0394in.] stroke	Mass of 1 sensor switch (With holder) ^{Note}		Additional mass		
	Basic type	Foot mounting type	Flange mounting type	Trunnion mounting type	ZC□□□		CS□T	Nut	Y type knuckle (With pin)	I type knuckle	
											kg [lb.]
125 [4.921]	15.9 [35.1] (14.3 [31.5])	17.6 [38.8] (16.0 [35.3])	18.4 [40.6] (16.8 [37.0])	19.3 [42.6] (17.7 [39.0])	0.0332 [0.732] (0.0243 [0.536])	0.07 [0.15]	0.07 [0.15]	0.2 [0.4]	1.5 [3.3]	1.5 [3.3]	
140 [5.512]	18.9 [41.7] (16.9 [37.3])	21.5 [47.4] (19.5 [43.0])	23.5 [51.8] (21.5 [47.4])	23.4 [51.6] (21.4 [47.2])	0.0367 [0.0809] (0.0250 [0.551])			0.2 [0.4]	1.6 [3.5]	1.9 [4.2]	
160 [6.299]	26.3 [58.0] (23.8 [52.5])	29.2 [64.4] (26.7 [58.9])	32.1 [70.8] (29.6 [65.3])	33.1 [73.0] (30.6 [67.5])	0.0451 [0.0994] (0.0318 [0.701])			0.3 [0.7]	2.1 [4.6]	2.8 [6.2]	
180 [7.087]	34.8 [76.7]	39.2 [86.4]	44.0 [97.0]	43.1 [95.0]	0.0620 [0.1367]	—	—	0.4 [0.9]	3.9 [8.6]	3.9 [8.6]	
200 [7.874]	43.6 [96.1]	48.4 [106.7]	54.4 [120.0]	55.2 [121.7]	0.0727 [0.1603]	—	—	0.6 [1.3]	3.7 [8.2]	4.0 [8.8]	

Remark: Figures in parentheses () are for cylinders with magnets.

Calculation example: For standard cylinder, foot mounting type, with bore size of 140mm and stroke 100mm, $21.5 + (0.0367 \times 100) = 25.17\text{kg}$ [55.50lb.]

Note: For lead wire length A (1000mm [39in.]).

Dimensions of Basic Type (mm)

KA0SDD Bore size X Stroke

SDD Bore size

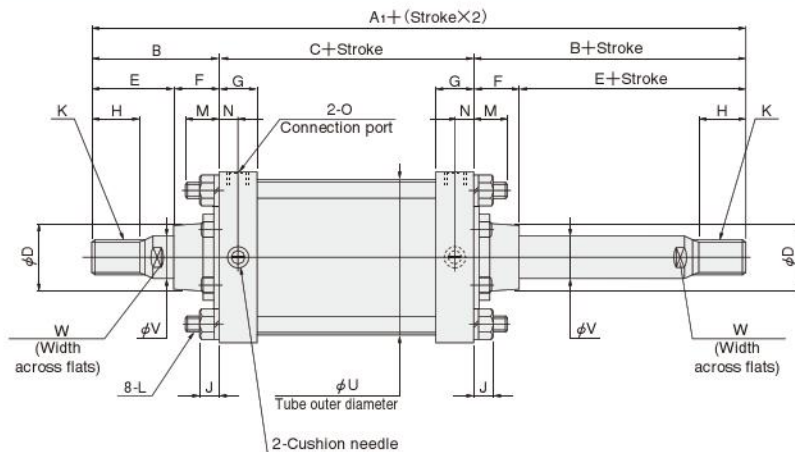
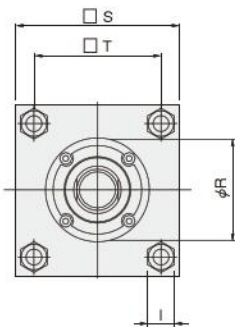

Bore size [in.]	Code	A ₁	B	C	D	E	F	G	H	I	J	K
125	[4.921]	318	110	98	60	72	38	35	50	22	14.5	M30×1.5
140	[5.512]	318	110	98	60	72	38	35	50	22	14.5	M30×1.5
160	[6.299]	346	120	106	60	82	38	39	56	24	17	M36×1.5
180	[7.087]	381	135	111	70	95	40	39	63	27	19.6	M40×1.5
200	[7.874]	381	135	111	70	95	40	39	63	30	21.1	M45×1.5

Bore size [in.]	Code	L	M	N	O	R	S	T	U	V	W
125	[4.921]	M14×1.5	27	16	Rc1/2	90 ^{-0.1} _{-0.2}	145	115	134(135)	35	32
140	[5.512]	M14×1.5	27	16	Rc1/2	90 ^{-0.1} _{-0.2}	160	128	150	35	32
160	[6.299]	M16×1.5	30.5	18.5	Rc3/4	90 ^{-0.1} _{-0.2}	182	144	170	40	36
180	[7.087]	M18×1.5	35	18.5	Rc3/4	115 ^{-0.1} _{-0.2}	204	162	193	45	41
200	[7.874]	M20×1.5	35	18.5	Rc3/4	115 ^{-0.1} _{-0.2}	226	182	213	50	46

Figures in parentheses () are for cylinders with magnets.

Dimensions of Foot Mounting Type (mm)

KA1SDD Bore size X Stroke

Foot mounting bracket only
 φ 125, φ 140 : SD-F01
 φ 160, φ 180 : SD-F02
 φ 200 : SD-F03

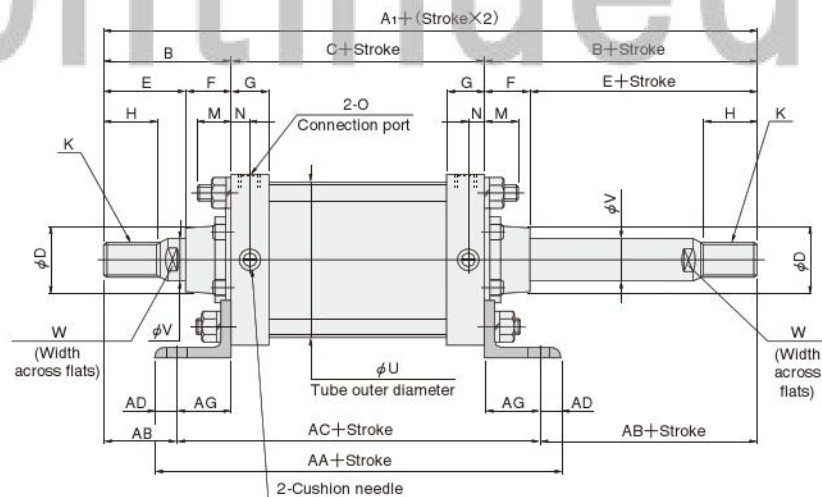
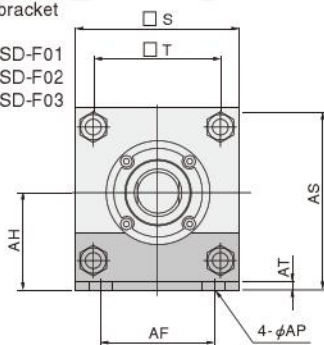

Bore size [in.]	Code	A ₁	B	C	D	E	F	G	H	K	M	N	O	S
125	[4.921]	318	110	98	60	72	38	35	50	M30×1.5	27	16	Rc1/2	145
140	[5.512]	318	110	98	60	72	38	35	50	M30×1.5	27	16	Rc1/2	160
160	[6.299]	346	120	106	60	82	38	39	56	M36×1.5	30.5	18.5	Rc3/4	182
180	[7.087]	381	135	111	70	95	40	39	63	M40×1.5	35	18.5	Rc3/4	204
200	[7.874]	381	135	111	70	95	40	39	63	M45×1.5	35	18.5	Rc3/4	226

Bore size [in.]	Code	T	U	V	W	AA	AB	AC	AD	AF	AG	AH	AP	AS	AT
125	[4.921]	115	134(135)	35	32	228	65	188	20	100	45	85	19	157.5	8
140	[5.512]	128	150	35	32	248	65	188	30	112	45	100	19	180	9
160	[6.299]	144	170	40	36	256	70	206	25	118	50	106	19	197	9
180	[7.087]	162	193	45	41	291	75	231	30	132	60	125	24	227	10
200	[7.874]	182	213	50	46	291	75	231	30	150	60	132	24	245	10

Figures in parentheses () are for cylinders with magnets.

Dimensions of Flange Mounting Type (mm)

KA3SDD Bore size X Stroke



Flange mounting bracket only

- φ 125, φ 140 :SD-RFR1
- φ 160, φ 180 :SD-RFR2
- φ 200 :SD-RFR3

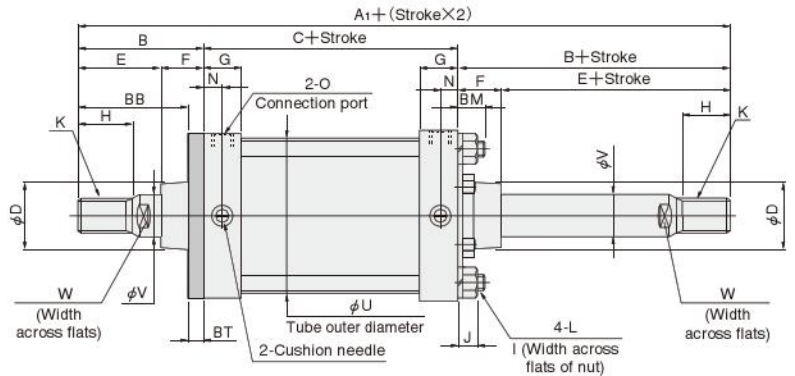
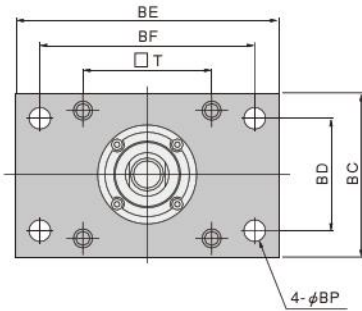

Bore size [in.]	Code	A ₁	B	C	D	E	F	G	H	I	J	K	L
125	[4.921]	318	110	98	60	72	38	35	50	22	14.5	M30×1.5	M14×1.5
140	[5.512]	318	110	98	60	72	38	35	50	22	14.5	M30×1.5	M14×1.5
160	[6.299]	346	120	106	60	82	38	39	56	24	17	M36×1.5	M16×1.5
180	[7.087]	381	135	111	70	95	40	39	63	27	19.6	M40×1.5	M18×1.5
200	[7.874]	381	135	111	70	95	40	39	63	30	21.1	M45×1.5	M20×1.5

Bore size [in.]	Code	N	O	T	U	V	W	BB	BC	BD	BE	BF	BM	BP	BT
125	[4.921]	16	Rc1/2	115	134(135)	35	32	96	145	100	230	190	23	19	14
140	[5.512]	16	Rc1/2	128	150	35	32	90	160	112	255	212	17	19	20
160	[6.299]	18.5	Rc3/4	144	170	40	36	100	182	118	275	236	20	19	20
180	[7.087]	18.5	Rc3/4	162	193	45	41	110	204	132	320	265	23	24	25
200	[7.874]	18.5	Rc3/4	182	213	50	46	110	226	150	335	280	25	24	25

Figures in parentheses () are for cylinders with magnets.

Dimensions of Trunnion Mounting Type (mm)

KA11SDD Bore size X Stroke



Trunnion mounting bracket only

- φ 125, φ 140 :SD-TR1
- φ 160, φ 180 :SD-TR2
- φ 200 :SD-TR3

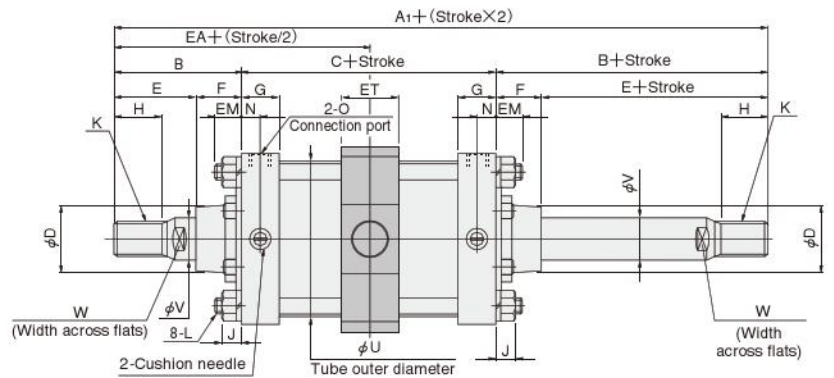
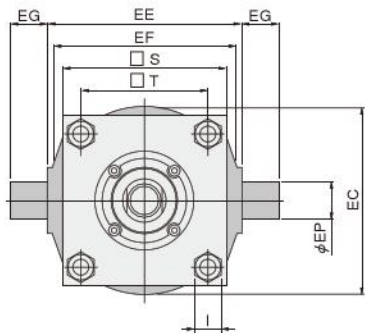

Bore size [in.]	Code	A ₁	B	C	D	E	F	G	H	I	J	K	L	N
125	[4.921]	318	110	98	60	72	38	35	50	22	14.5	M30×1.5	M14×1.5	16
140	[5.512]	318	110	98	60	72	38	35	50	22	14.5	M30×1.5	M14×1.5	16
160	[6.299]	346	120	106	60	82	38	39	56	24	17	M36×1.5	M16×1.5	18.5
180	[7.087]	381	135	111	70	95	40	39	63	27	19.6	M40×1.5	M18×1.5	18.5
200	[7.874]	381	135	111	70	95	40	39	63	30	21.1	M45×1.5	M20×1.5	18.5

Bore size [in.]	Code	O	S	T	U	V	W	EA	EC	EE	EF	EG	EM	EP	ET
125	[4.921]	Rc1/2	145	115	134(135)	35	32	159	164	170 ^{-0.1} _{-0.4}	160	32	18	32 ^{-0.050} _{-0.089}	50
140	[5.512]	Rc1/2	160	128	150	35	32	159	184	190 ^{-0.1} _{-0.4}	180	36	18	36 ^{-0.050} _{-0.089}	55
160	[6.299]	Rc3/4	182	144	170	40	36	173	208	212 ^{-0.1} _{-0.4}	200	40	19.5	40 ^{-0.050} _{-0.089}	60
180	[7.087]	Rc3/4	204	162	193	45	41	190.5	225	236 ^{-0.1} _{-0.6}	225	45	23.5	45 ^{-0.050} _{-0.089}	62
200	[7.874]	Rc3/4	226	182	213	50	46	190.5	255	265 ^{-0.1} _{-0.6}	255	45	24.5	45 ^{-0.050} _{-0.089}	67

Figures in parentheses () are for cylinders with magnets.

SD TANDEM CYLINDERS



Symbol

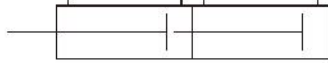

Specifications

Item	Bore size mm [in.]	125 [4.921]	140 [5.512]	160 [6.299]	180 [7.087] ^{Note}	200 [7.874] ^{Note}
Operation type		Double acting type				
Media		Air				
Mounting type		Basic type, Foot type, Rod side flange type, Head side flange type, Clevis type, Pivot type, Trunnion type				
Operating pressure range	MPa [psi.]	0.05~0.7 [7~102]				
Proof pressure	MPa [psi.]	1.05 [152]				
Operating temperature range	°C [°F]	0~60 [32~140]				
Operating speed range	mm/s [in./sec.]	30~500 [1.2~19.7]				
Cushion stroke	mm [in.]	26 [1.024]			28 [1.102]	
Lubrication		Not required				
Port size	Rc	1/2			3/4	

Note: Cylinder with magnet is not available.

Bore Size and Stroke

	Bore size	Standard strokes (Stroke1×2+Stroke2)	Maximum available stroke (Stroke1×2+Stroke2)
Standard cylinder	125	0~1000	1000
	140		
	160		
	180		
	200		
Cylinder with magnet	125	0~990	990
	140		
	160		

The strokes listed below or larger should be included with class 2 pressure vessels.

Bore size	Cylinder stroke
125	3640
140	2615
160	1990
180	1573
200	1000

Caution Do not use SD tandem cylinders with double the cylinder thrust.

Remarks: 1. Stroke tolerance:

Stroke tolerance for strokes of 250mm or less: $+1.0 \left[+0.039\text{in.} \right]$,
strokes of 251~1000mm: $+1.4 \left[+0.055\text{in.} \right]$

2. Minimum available stroke of trunnion mounting type is
φ 125: 22mm, φ 140: 27mm, φ 160: 32mm, φ 180: 29mm, and
φ 200: 34mm.

● About stroke 1 and stroke 2

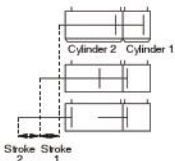

Stroke 1 is the stroke of cylinder 1.
Stroke 2 is obtained by subtracting stroke 1
from the stroke of cylinder 2.

Order Codes

KA **SD** **125×100×100** — — — — —

Bore size
×
Stroke 1
×
Stroke 2

Piston rod specification
Blank — Standard type
RS — SUS rod
(Available as a special.
For delivery, consult us.)

Number of sensor switches
1 — With 1 sensor switch
2 — With 2 sensor switches
3 — With 3 sensor switches
:
:
:

Lead wire length
A — 1000mm [39in.]
B — 3000mm [118in.]

Mounting type
0 — Basic type
1 — Foot mounting type
3 — Rod side flange mounting type
5 — Head side flange mounting type
7 — Clevis mounting type (with pin)
8 — Pivot mounting type
11 — Trunnion mounting type

Sensor specification
Blank — Standard cylinder
S — Cylinder with magnet
(Not available in ϕ 180 [7.087in.]
and ϕ 200 [7.874in.]

Cylinder specification
T — Tandem cylinder
JT — Tandem cylinder with bellows
TY — Tandem cylinder with heavy duty dust scraper
(Available as a special)
● For delivery, consult us.

Sensor switch (For the cylinder with magnet)
ZC130 — 2-lead wire Solid state type with indicator lamp DC10~28V
ZC153 — 3-lead wire Solid state type with indicator lamp DC4.5~28V
CS5T — 2-lead wire Reed switch type without indicator lamp DC5~28V
CS11T — 2-lead wire Reed switch type with indicator lamp AC85~115V DC10~28V
● For details of sensor switches, see p.1544.

Rod end accessory
Blank — No rod end accessory
Y — With Y type knuckle (with pin)
I — With I type knuckle

Rod end nut
Blank — No nut
N1 — With 1 nut
N2 — With 2 nuts

Mass

Bore size mm [in.]	Zero stroke mass						Additional mass for each 1mm [0.0394in.] stroke		Mass of 1 sensor switch (With holder) ^{NOTE}		Additional mass		
	Basic type	Foot mounting type	Flange mounting type	Clevis mounting type (With pin)	Pivot mounting type	Trunnion mounting type	Stroke 1	Stroke 2	ZC□□□	CS□T	Nut	Y type knuckle (With pin)	I type knuckle
125 [4.921]	28.9 [63.7] (25.7 [56.7])	30.6 [67.5] (27.4 [60.4])	31.4 [69.2] (28.2 [62.2])	32.8 [72.3] (29.6 [65.3])	32.4 [71.4] (29.2 [64.4])	32.3 [71.2] (29.1 [64.2])	0.0516 [0.1138] (0.0338 [0.0745])	0.0256 [0.0564] (0.0167 [0.0368])	0.07 [0.15]	0.07 [0.15]	0.2 [0.4]	1.5 [3.3]	1.5 [3.3]
140 [5.512]	34.9 [77.0] (30.9 [68.1])	37.5 [82.7] (33.5 [73.9])	39.5 [87.1] (35.5 [78.3])	40.1 [88.4] (36.5 [80.5])	39.7 [87.5] (35.7 [78.7])	39.4 [86.9] (35.4 [78.1])	0.0586 [0.1282] (0.0352 [0.0776])	0.0291 [0.0642] (0.0174 [0.0384])			0.2 [0.4]	1.6 [3.5]	1.9 [4.2]
160 [6.299]	48.8 [107.6] (43.8 [96.6])	51.7 [114.0] (46.7 [103.0])	54.6 [120.4] (49.6 [109.4])	55.8 [123.0] (50.8 [112.0])	55.0 [121.3] (50.0 [110.3])	55.6 [122.6] (50.6 [111.6])	0.0704 [0.1552] (0.0438 [0.0966])	0.0352 [0.0776] (0.0219 [0.0483])	0.3 [0.7]	2.1 [4.6]	2.8 [6.2]		
180 [7.087]	63.7 [140.5]	68.1 [150.2]	72.9 [160.7]	75.3 [166.0]	73.7 [162.5]	72.0 [158.8]	0.0990 [0.2183]	0.0495 [0.1091]	0.4 [0.9]	3.9 [8.6]	3.9 [8.6]		
200 [7.874]	79.3 [174.9]	84.1 [185.4]	90.1 [198.7]	91.5 [201.8]	91.3 [201.3]	90.9 [200.4]	0.1146 [0.2527]	0.0573 [0.1263]	0.6 [1.3]	3.7 [8.2]	4.0 [8.8]		

Remark: Figures in parentheses () are for cylinders with magnets.
 Calculation example: For standard cylinder, foot mounting type, with bore size of 140mm, Stroke 1 of 100mm and Stroke 2 of 50mm,
 $37.5 - (0.0586 \times 100) + (0.0291 \times 50) = 44.815\text{kg} [98.799\text{lb.}]$
 Note: For lead wire length A (1000mm [39in.]).

Operation of Tandem Cylinders

Tandem Cylinders are a set of 2 cylinders joined end to end. It can be used as a 2-stage stroke cylinder by supplying air to either Port A or Port B.

Caution Do not use SD tandem cylinders with double the cylinder thrust.

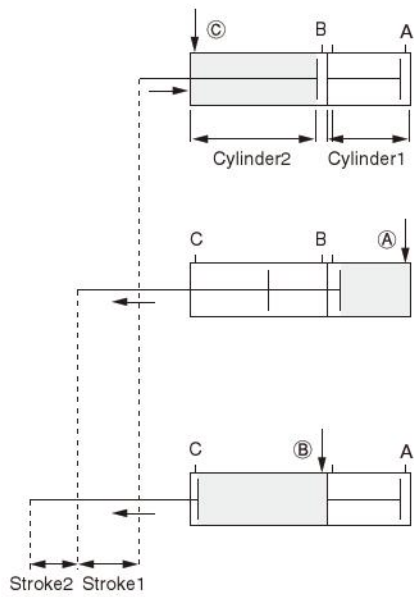

The rods retract strokes 2 and 1 when air is supplied from Port C.

The rod moves stroke 1 when air is supplied from Port A.

The rod moves stroke 2 when air is supplied from Port B.

Inner Construction and Major Parts

● Cushion

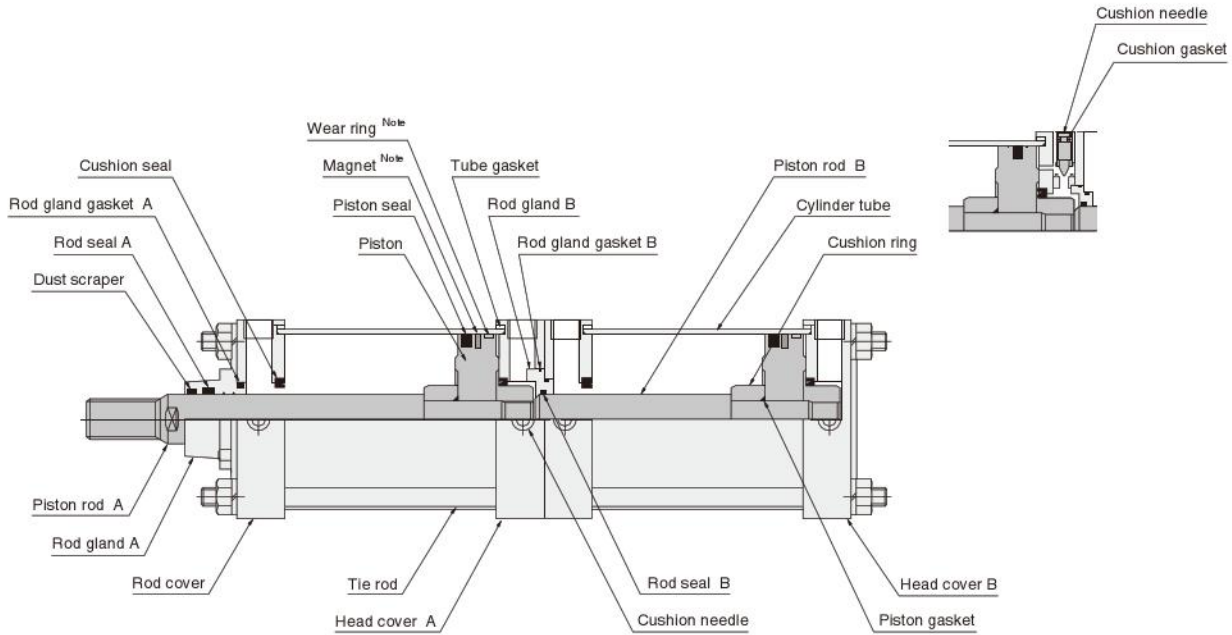

Note: For cylinders with magnets.

Major Parts and Materials

Parts	Bore size mm	125	140	160	180	200
Cylinder tube	Standard cylinder	Steel pipe (inside: hard chrome plated, outside: silver metallic painted)				
	Cylinder with magnet	Aluminum alloy (hard anodized)				
Piston		Cast iron ^{Note}				
Piston rod A		Steel (hard chrome plated)				
Piston rod B		(-RS : SUS)				
Cushion ring		Mild steel (zinc plated)				
Rod cover		Mild steel (black oxide)				
Head cover A						
Head cover B						
Tie rod		Mild steel (zinc plated)				
Rod gland A		Aluminum alloy (hard anodized)				
Rod gland B		Copper alloy				

Parts	Bore size mm	125	140	160	180	200
Wear ring		Plastic				
Magnet		Rubber magnet				
Seal		Synthetic rubber (NBR)				
Foot mounting bracket		Mild steel (painted)				
Flange mounting bracket		Cast iron (manganese treated)				
Clevis mounting bracket						
Pivot mounting bracket						
Trunnion mounting bracket		Cast iron (manganese treated)				
Bellows		Nylon tarpaulin				
I type knuckle		Mild steel (alkali coloring)				
Y type knuckle		Cast iron (manganese treated)				
Pin		Steel (zinc plated)				

Note: The cylinder with magnet is aluminum alloy.

Seals

Item	Dust scraper ★	Rod seal A ★	Rod seal B	Rod gland gasket A	Rod gland gasket B	Cylinder tube gasket ★	Cushion seal	Piston seal ★	Piston gasket	Cushion gasket	
Bore size mm	Quantity	1	1	1	2	1	4	4	2	2	4
125	SDR-35	PNY-35	P-35	G-50	S-67	S-120	PCS-50	PWP-125N	G-25	P-7	
140	SDR-35	PNY-35	P-35	G-50	S-67	S-135	PCS-50	PWP-140N	G-25	P-7	
160	SDR-40	PNY-40	P-40	G-50	S-67	#160	PCS-50	PWP-160N	G-25	P-7	
180	SDR-45	PNY-45	P-45	G-60	S-80	#180	PCS-60	PSD-180	G-35	P-7	
200	SDR-50	PNY-50	P-50	G-60	S-80	#200	PCS-60	PSD-200	G-35	P-7	

Remark : Items marked with a star (★) are available as repair kits. The order code is the **SRK-NSD** [Bore size].

Note that the contents of a repair kit is 1 dust scraper, 1 rod seal, 1 piston seal, and 2 cylinder tube gaskets.

Note, however, that the repair kits with bore size of 125mm and 140mm cannot be used with SD cylinders manufactured prior to April 6, 2000 (because the piston rod diameters have been changed). For details, see p.543.

Dimensions of Basic Type (mm)

KA0SDT Bore size × Stroke 1 × Stroke 2

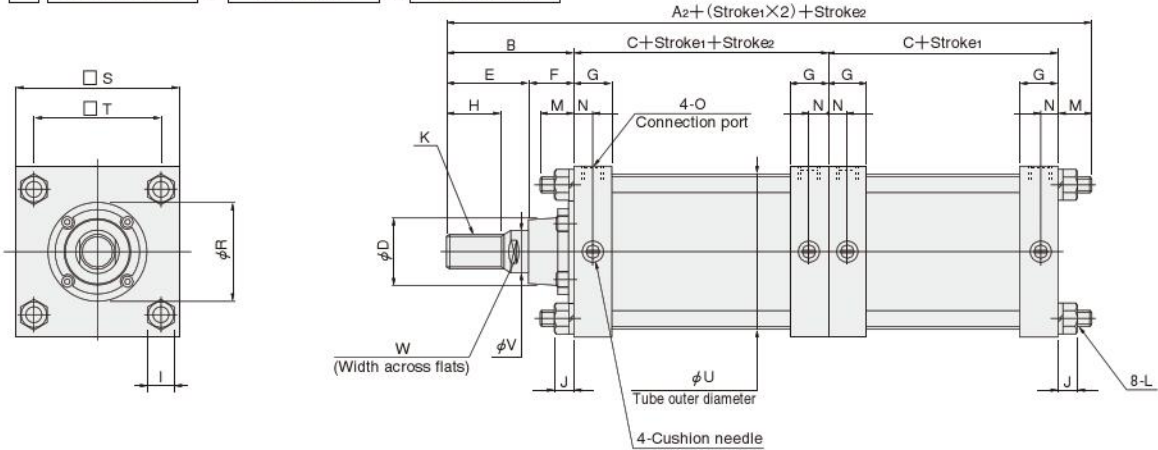

Bore max [in.]	Code	A ₂	B	C	D	E	F	G	H	I	J	K
125 [4.921]		333	110	98	60	72	38	35	50	22	14.5	M30 × 1.5
140 [5.512]		333	110	98	60	72	38	35	50	22	14.5	M30 × 1.5
160 [6.299]		362.5	120	106	60	82	38	39	56	24	17	M36 × 1.5
180 [7.087]		392	135	111	70	95	40	39	63	27	19.6	M40 × 1.5
200 [7.874]		392	135	111	70	95	40	39	63	30	21.1	M45 × 1.5

Bore max [in.]	Code	L	M	N	O	R	S	T	U	V	W
125 [4.921]		M14 × 1.5	27	16	Rc1/2	90 ^{-0.1} _{-0.2}	145	115	134(135)	35	32
140 [5.512]		M14 × 1.5	27	16	Rc1/2	90 ^{-0.1} _{-0.2}	160	128	150	35	32
160 [6.299]		M16 × 1.5	30.5	18.5	Rc3/4	90 ^{-0.1} _{-0.2}	182	144	170	40	36
180 [7.087]		M18 × 1.5	35	18.5	Rc3/4	115 ^{-0.1} _{-0.2}	204	162	193	45	41
200 [7.874]		M20 × 1.5	35	18.5	Rc3/4	115 ^{-0.1} _{-0.2}	226	182	213	50	46

Figures in parentheses () are for cylinders with magnets.

Dimensions of Foot Mounting Type (mm)

KA1SDT Bore size × Stroke 1 × Stroke 2

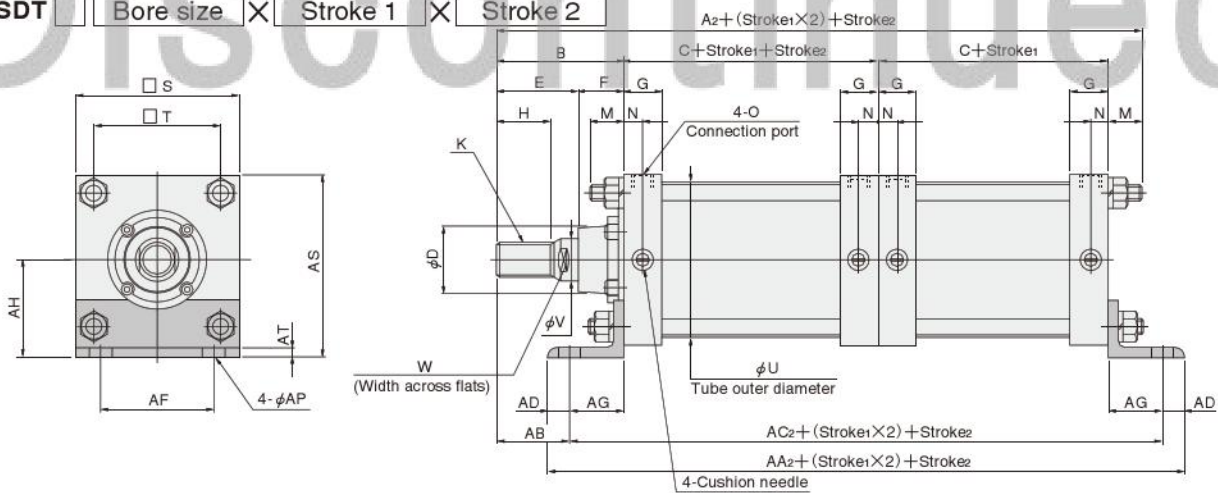

Bore max [in.]	Code	A ₂	B	C	D	E	F	G	H	K	M	N	O	S	T
125 [4.921]		333	110	98	60	72	38	35	50	M30 × 1.5	27	16	Rc1/2	145	115
140 [5.512]		333	110	98	60	72	38	35	50	M30 × 1.5	27	16	Rc1/2	160	128
160 [6.299]		362.5	120	106	60	82	38	39	56	M36 × 1.5	30.5	18.5	Rc3/4	182	144
180 [7.087]		392	135	111	70	95	40	39	63	M40 × 1.5	35	18.5	Rc3/4	204	162
200 [7.874]		392	135	111	70	95	40	39	63	M45 × 1.5	35	18.5	Rc3/4	226	182

Bore max [in.]	Code	U	V	W	AA ₂	AB	AC ₂	AD	AF	AG	AH	AP	AS	AT
125 [4.921]		134(135)	35	32	326	65	286	20	100	45	85	19	157.5	8
140 [5.512]		150	35	32	346	65	286	30	112	45	100	19	180	9
160 [6.299]		170	40	36	362	70	312	25	118	50	108	19	197	9
180 [7.087]		193	45	41	402	75	342	30	132	60	125	24	227	10
200 [7.874]		213	50	46	402	75	342	30	150	60	132	24	245	10

Figures in parentheses () are for cylinders with magnets.

Dimensions of Rod Side Flange Mounting Type (mm)

KA3SDT Bore size × Stroke 1 × Stroke 2

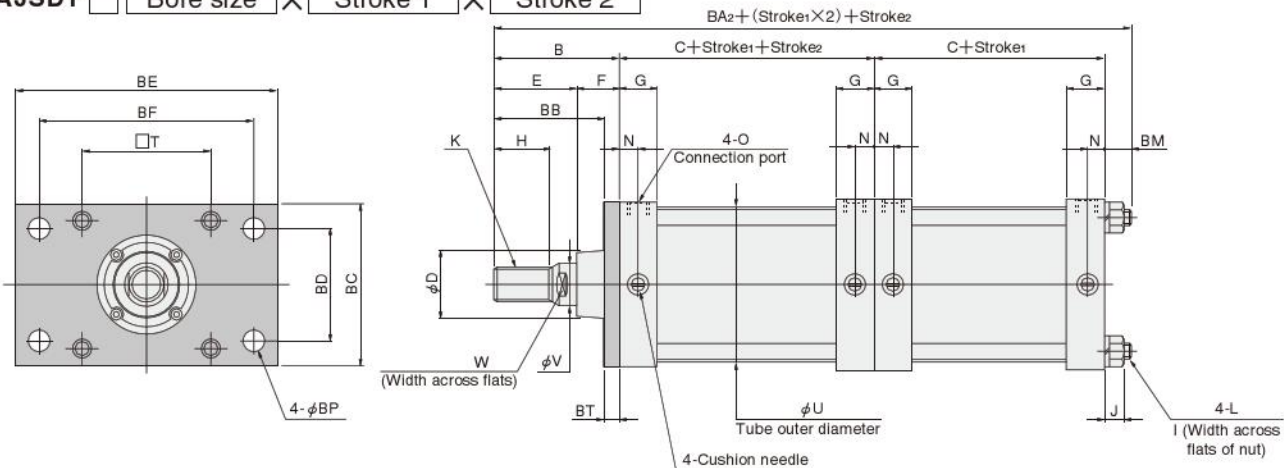

Bore mm [in.]	Code	B	C	D	E	F	G	H	I	J	K	L	N
125	[4.921]	110	98	60	72	38	35	50	22	14.5	M30×1.5	M14×1.5	16
140	[5.512]	110	98	60	72	38	35	50	22	14.5	M30×1.5	M14×1.5	16
160	[6.299]	120	106	60	82	38	39	56	24	17	M36×1.5	M16×1.5	18.5
180	[7.087]	135	111	70	95	40	39	63	27	19.6	M40×1.5	M18×1.5	18.5
200	[7.874]	135	111	70	95	40	39	63	30	21.1	M45×1.5	M20×1.5	18.5

Bore mm [in.]	Code	O	T	U	V	W	BA ₂	BB	BC	BD	BE	BF	BM	BP	BT
125	[4.921]	Rc1/2	115	134(135)	35	32	329	96	145	100	230	190	23	19	14
140	[5.512]	Rc1/2	128	150	35	32	323	90	160	112	255	212	17	19	20
160	[6.299]	Rc3/4	144	170	40	36	352	100	182	118	275	236	20	19	20
180	[7.087]	Rc3/4	162	193	45	41	380	110	204	132	320	265	23	24	25
200	[7.874]	Rc3/4	182	213	50	46	382	110	226	150	335	280	25	24	25

Figures in parentheses () are for cylinders with magnets.

Dimensions of Head Side Flange Mounting Type (mm)

KA5SDT Bore size × Stroke 1 × Stroke 2

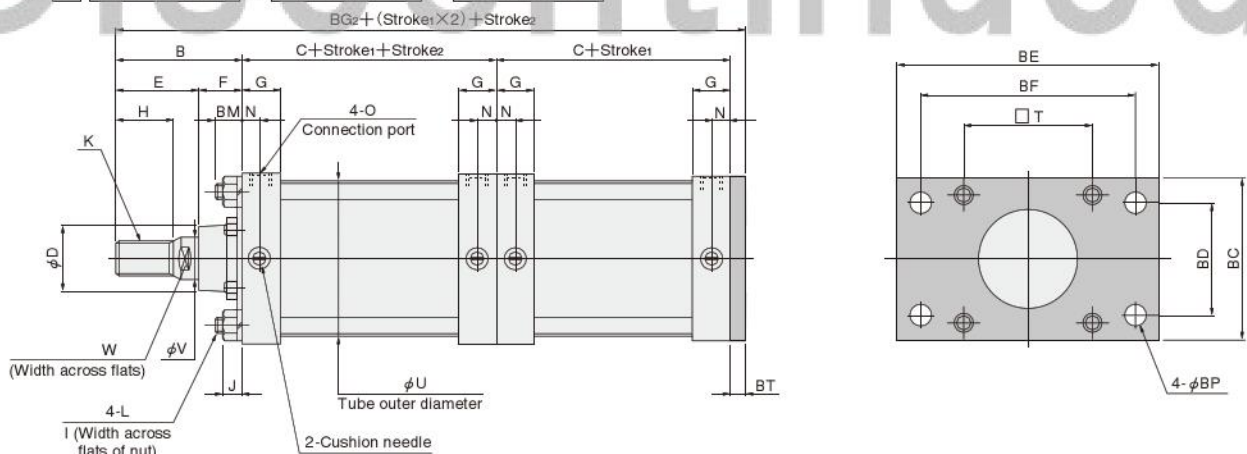

Bore mm [in.]	Code	B	C	D	E	F	G	H	I	J	K	L	N
125	[4.921]	110	98	60	72	38	35	50	22	14.5	M30×1.5	M14×1.5	16
140	[5.512]	110	98	60	72	38	35	50	22	14.5	M30×1.5	M14×1.5	16
160	[6.299]	120	106	60	82	38	39	56	24	17	M36×1.5	M16×1.5	18.5
180	[7.087]	135	111	70	95	40	39	63	27	19.6	M40×1.5	M18×1.5	18.5
200	[7.874]	135	111	70	95	40	39	63	30	21.1	M45×1.5	M20×1.5	18.5

Bore mm [in.]	Code	O	T	U	V	W	BC	BD	BE	BF	BG ₂	BM	BP	BT
125	[4.921]	Rc1/2	115	134(135)	35	32	145	100	230	190	320	23	19	14
140	[5.512]	Rc1/2	128	150	35	32	160	112	255	212	326	17	19	20
160	[6.299]	Rc3/4	144	170	40	36	182	118	275	236	352	20	19	20
180	[7.087]	Rc3/4	162	193	45	41	204	132	320	265	382	23	24	25
200	[7.874]	Rc3/4	182	213	50	46	226	150	335	280	382	25	24	25

Figures in parentheses () are for cylinders with magnets.

Dimensions of Clevis Mounting Type (mm)

KA7SDT Bore size Stroke 1 Stroke 2

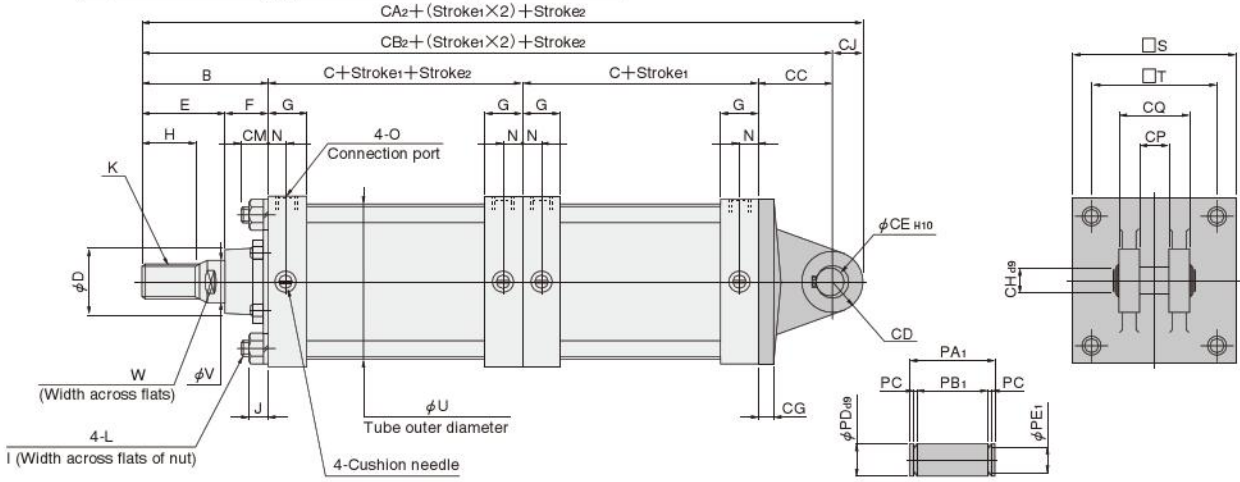

Bore mm [in.]	Code	B	C	D	E	F	G	H	I	J	K	L	N	O	S	T	U
125 [4.921]		110	98	60	72	38	35	50	22	14.5	M30×1.5	M14×1.5	16	Rc1/2	145	115	134(135)
140 [5.512]		110	98	60	72	38	35	50	22	14.5	M30×1.5	M14×1.5	16	Rc1/2	160	128	150
160 [6.299]		120	106	60	82	38	39	56	24	17	M36×1.5	M16×1.5	18.5	Rc3/4	182	144	170
180 [7.087]		135	111	70	95	40	39	63	27	19.6	M40×1.5	M18×1.5	18.5	Rc3/4	204	162	193
200 [7.874]		135	111	70	95	40	39	63	30	21.1	M45×1.5	M20×1.5	18.5	Rc3/4	226	182	213

Bore mm [in.]	Code	V	W	CA ₂	CB ₂	CC	CD	CE	CG	CH	CJ	CM	CP	CQ	PA ₁	PB ₁	PC	PD	PE ₁
125 [4.921]		35	32	399	371	65	R28	25 ^{+0.084} ₀	18	25 ^{-0.065} _{-0.117}	28	19	32 ^{+0.4} _{+0.1}	64 ^{-0.1} _{-0.4}	73	65 ±0.5	1.35 ^{+0.14} ₀	25 ^{-0.065} _{-0.117}	23.9 ⁰ _{-0.21}
140 [5.512]		35	32	413	381	75	R32	28 ^{+0.084} ₀	20	28 ^{-0.065} _{-0.117}	32	17	36 ^{+0.4} _{+0.1}	72 ^{-0.1} _{-0.4}	82	73 ±0.5	1.65 ^{+0.14} ₀	28 ^{-0.065} _{-0.117}	26.6 ⁰ _{-0.21}
160 [6.299]		40	36	448	412	80	R36	32 ^{+0.100} ₀	20	32 ^{-0.080} _{-0.142}	36	20	40 ^{+0.4} _{+0.1}	80 ^{-0.1} _{-0.4}	90	81 ±0.5	1.65 ^{+0.14} ₀	32 ^{-0.080} _{-0.142}	30.3 ⁰ _{-0.25}
180 [7.087]		45	41	490	447	90	R43	40 ^{+0.100} ₀	25	40 ^{-0.080} _{-0.142}	43	23	50 ^{+0.4} _{+0.1}	100 ^{-0.1} _{-0.4}	113	101.5 ±0.5	1.9 ^{+0.14} ₀	40 ^{-0.080} _{-0.142}	38 ⁰ _{-0.25}
200 [7.874]		50	46	492	447	90	R45	40 ^{+0.100} ₀	25	40 ^{-0.080} _{-0.142}	45	25	50 ^{+0.4} _{+0.1}	100 ^{-0.1} _{-0.4}	113	101.5 ±0.5	1.9 ^{+0.14} ₀	40 ^{-0.080} _{-0.142}	38 ⁰ _{-0.25}

Figures in parentheses () are for cylinders with magnets.

Dimensions of Pivot Mounting Type (mm)

KA8SDT Bore size Stroke 1 Stroke 2

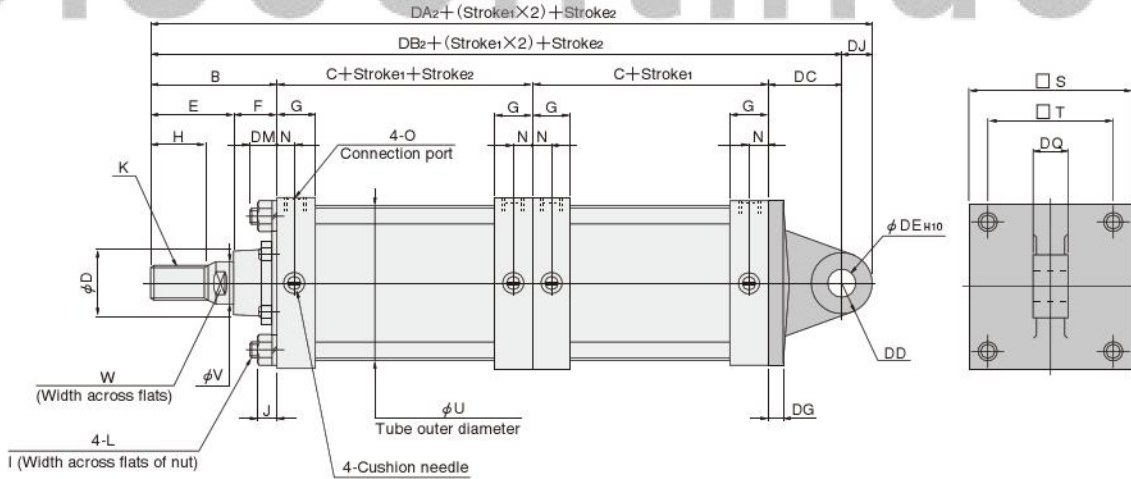

Bore mm [in.]	Code	B	C	D	E	F	G	H	I	J	K	L	N	O
125 [4.921]		110	98	60	72	38	35	50	22	14.5	M30×1.5	M14×1.5	16	Rc1/2
140 [5.512]		110	98	60	72	38	35	50	22	14.5	M30×1.5	M14×1.5	16	Rc1/2
160 [6.299]		120	106	60	82	38	39	56	24	17	M36×1.5	M16×1.5	18.5	Rc3/4
180 [7.087]		135	111	70	95	40	39	63	27	19.6	M40×1.5	M18×1.5	18.5	Rc3/4
200 [7.874]		135	111	70	95	40	39	63	30	21.1	M45×1.5	M20×1.5	18.5	Rc3/4

Bore mm [in.]	Code	S	T	U	V	W	DB ₂	DC	DD	DE	DG	DM	DQ	DJ
125 [4.921]		145	115	134(135)	35	32	371	65	R28	25 ^{+0.084} ₀	18	19	32 ^{-0.1} _{-0.4}	28
140 [5.512]		160	128	150	35	32	371	75	R32	28 ^{+0.084} ₀	20	17	36 ^{-0.1} _{-0.4}	32
160 [6.299]		182	144	170	40	36	412	80	R36	32 ^{+0.100} ₀	20	20	40 ^{-0.1} _{-0.4}	36
180 [7.087]		204	162	193	45	41	447	90	R43	40 ^{+0.100} ₀	25	23	50 ^{-0.1} _{-0.4}	43
200 [7.874]		226	182	213	50	46	447	90	R45	40 ^{+0.100} ₀	25	25	50 ^{-0.1} _{-0.4}	45

Figures in parentheses () are for cylinders with magnets.

Dimensions of Trunnion Mounting Type (mm)

KA11SDT Bore size × Stroke 1 × Stroke 2

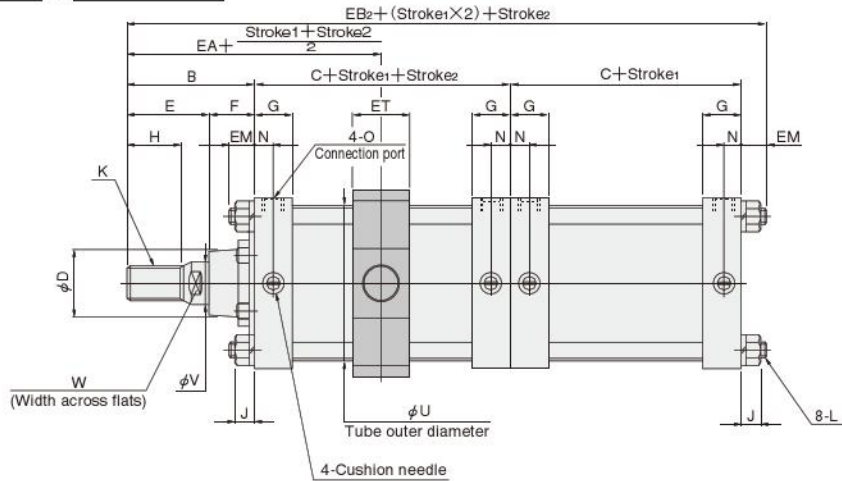
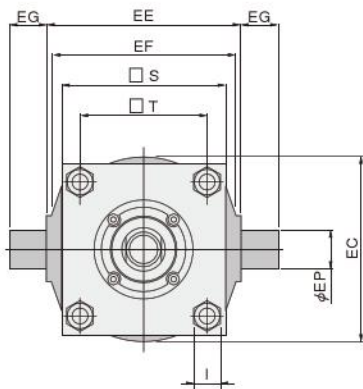

Bore mm [in.]	Code	B	C	D	E	F	G	H	I	J	K	L	N	O
125 [4.921]		110	98	60	72	38	35	50	22	14.5	M30 × 1.5	M14 × 1.5	16	Rc1/2
140 [5.512]		110	98	60	72	38	35	50	22	14.5	M30 × 1.5	M14 × 1.5	16	Rc1/2
160 [6.299]		120	106	60	82	38	39	56	24	17	M36 × 1.5	M16 × 1.5	18.5	Rc3/4
180 [7.087]		135	111	70	95	40	39	63	27	19.6	M40 × 1.5	M18 × 1.5	18.5	Rc3/4
200 [7.874]		135	111	70	95	40	39	63	30	21.1	M45 × 1.5	M20 × 1.5	18.5	Rc3/4

Bore mm [in.]	Code	S	T	U	V	W	EA	EB ₂	EC	EE	EF	EG	EM	EP	ET
125 [4.921]		145	115	134(135)	35	32	159	324	164	170 ^{-0.1} _{-0.4}	160	32	18	32 ^{-0.050} _{-0.089}	50
140 [5.512]		160	128	150	35	32	159	324	184	190 ^{-0.1} _{-0.4}	180	36	18	36 ^{-0.050} _{-0.089}	55
160 [6.299]		182	144	170	40	36	173	351.5	208	212 ^{-0.1} _{-0.4}	200	40	19.5	40 ^{-0.050} _{-0.089}	60
180 [7.087]		204	162	193	45	41	190.5	380.5	225	236 ^{-0.1} _{-0.6}	225	45	23.5	45 ^{-0.050} _{-0.089}	62
200 [7.874]		226	182	213	50	46	190.5	381.5	255	265 ^{-0.1} _{-0.6}	255	45	24.5	45 ^{-0.050} _{-0.089}	67

Figures in parentheses () are for cylinders with magnets.

Discontinued

SD DUAL STROKE CYLINDERS



Symbol



Specifications

Item	Bore size mm [in.]	125 [4.921]	140 [5.512]	160 [6.299]	180 [7.087] ^{Note}	200 [7.874] ^{Note}
Operation type		Double acting type				
Media		Air				
Mounting type		Basic type, Foot type, Flange type, Trunnion type				
Operating pressure range	MPa [psi.]	0.05~0.7 [7~102]				
Proof pressure	MPa [psi.]	1.05 [152]				
Operating temperature range	°C [°F]	0~60 [32~140]				
Operating speed range	mm/s [in./sec.]	30~500 [1.2~19.7]				
Cushion stroke	mm [in.]	26 [1.024]			28 [1.102]	
Lubrication		Not required				
Port size	Rc	1/2			3/4	

Note: Cylinder with magnet is not available.

Bore Size and Stroke

	Bore size	mm	
		Standard strokes (Stroke1 + Stroke2)	Maximum available stroke (Stroke1 + Stroke2)
Standard cylinder	125	0~1000	1000
	140		
	160		
	180		
	200		
Cylinder with magnet	125	0~1000	1000
	140		
	160		

The strokes listed below or larger should be included with class 2 pressure vessels.

Bore size	Cylinder stroke
125	3640
140	2615
160	1990
180	1573
200	1000

Remarks: 1. Stroke tolerance:

Stroke tolerance for strokes of 250mm or less: $+1.0 \left[+0.039 \text{in.} \right]$,
strokes of 251~1000mm: $+1.4 \left[+0.055 \text{in.} \right]$

2. Minimum available stroke of trunnion mounting type is
φ 125: 22mm, φ 140: 27mm, φ 160: 32mm, φ 180: 29mm, and
φ 200: 34mm.

● About stroke 1 and stroke 2

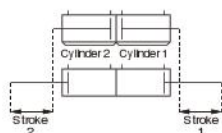

Stroke 1 is the stroke of cylinder 1.
Stroke 2 is the stroke of cylinder 2.

Order Codes

KA SD **125×100×100** - - - -

Bore size
×
Stroke1
×
Stroke2

Mounting type
0 — Basic type
1 — Foot mounting type
3 — Flange mounting type
11 — Trunnion mounting type

Sensor specification
Blank — Standard cylinder
S — Cylinder with magnet (Not available in ϕ 180 and ϕ 200.)

Cylinder specification
W — Dual stroke cylinder
JW — Dual stroke cylinder with bellows (on both sides)
WY — Dual stroke cylinder with heavy duty dust scraper (Available as a special, dust scrapers on both sides)
● For delivery, consult us.

Rod end nut
Blank — No nut
N1 — With 1 nut
N2 — With 2 nuts

Piston rod specification
Blank — Standard type
RS — SUS rod (Available as a special.)
(For delivery, consult us.)

Lead wire length
A — 1000mm [39in.]
B — 3000mm [118in.]

Number of sensor switches
1 — With 1 sensor switch
2 — With 2 sensor switches
3 — With 3 sensor switches
⋮

Sensor switch (For the cylinder with magnet)
ZC130 — 2-lead wire Solid state type with indicator lamp DC10~28V
ZC153 — 3-lead wire Solid state type with indicator lamp DC4.5~28V
CS5T — 2-lead wire Reed switch type without indicator lamp DC5~28V AC85~115V
CS11T — 2-lead wire Reed switch type with indicator lamp DC10~28V
● For details of sensor switches, see p.1544.

Rod end accessory
Blank — No rod end accessory
Y — With Y type knuckle (with pin)
I — With I type knuckle
● Rod end accessories are mounted on both sides.

SD CYLINDERS

Mass

Bore size mm [in.]	Zero stroke mass				Additional mass for each 1mm [0.0394in.] stroke Note 1	Mass of 1 sensor switch (With holder) Note 2		Additional mass		
	Basic type	Foot mounting type	Flange mounting type	Trunnion mounting type		ZC□□□	CS□T	Nut	Y type knuckle (With pin)	I type knuckle
125 [4.921]	29.2 [64.4] (26.0 [57.3])	30.9 [68.1] (27.7 [61.1])	31.7 [69.9] (28.5 [62.8])	32.6 [71.9] (29.4 [64.8])	0.0256 [0.0564] (0.0167 [0.0368])	0.07 [0.15]	0.07 [0.15]	0.2 [0.4]	1.5 [3.3]	1.5 [3.3]
140 [5.512]	35.2 [77.6] (31.2 [68.8])	37.8 [83.3] (33.8 [74.5])	39.8 [87.8] (35.8 [78.9])	39.7 [87.5] (35.7 [78.7])	0.0291 [0.0642] (0.0174 [0.0384])			0.2 [0.4]	1.6 [3.5]	1.9 [4.2]
160 [6.299]	49.2 [108.5] (44.2 [97.5])	52.1 [114.9] (47.1 [103.9])	55.0 [121.3] (50.0 [110.3])	56.0 [123.5] (51.0 [112.5])	0.0352 [0.0776] (0.0219 [0.0483])			0.3 [0.7]	2.1 [4.6]	2.8 [6.2]
180 [7.087]	64.3 [141.8]	68.7 [151.5]	73.5 [162.1]	72.6 [160.1]	0.0495 [0.1091]			—	—	0.4 [0.9]
200 [7.874]	80.6 [177.7]	85.4 [188.3]	91.4 [201.5]	92.2 [203.3]	0.0573 [0.1263]	—	—	0.6 [1.3]	3.7 [8.2]	4.0 [8.8]

Notes: 1. Applicable to both Stroke 1 and Stroke 2.

2. For lead wire length A (1000mm [39in.]).

Remark: Figures in parentheses () are for cylinders with magnets.

Calculation example: For standard cylinder, foot mounting type, with bore size of 140mm, Stroke 1 of 100mm and Stroke 2 of 50mm,
 $37.8 + (0.0291 \times 100) + (0.0291 \times 50) = 42.165\text{kg} [92.957\text{lb.}]$

Operation of Dual Stroke Cylinders

Dual Stroke Cylinders are a set of 2 cylinders connected back to back.

The cylinder body can be secured in place and each stroke can be controlled separately. It can also be used to obtain 2-stage or 3-stage strokes by securing the piston rod on one side in place.

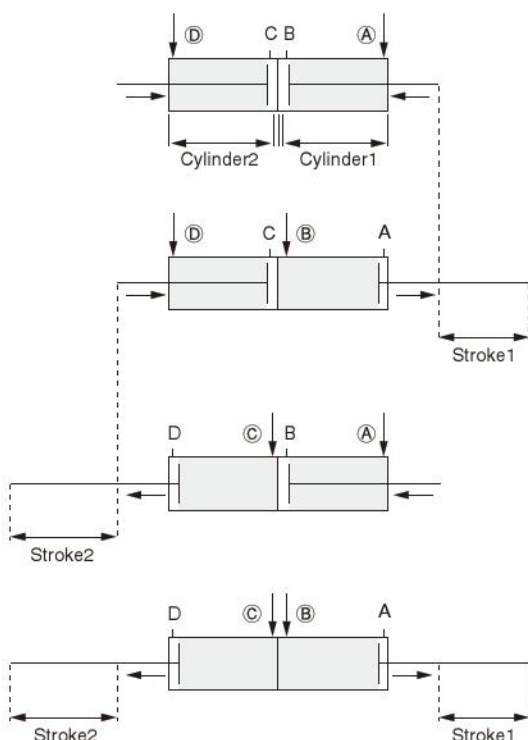

The rods retract stroke 1 and stroke 2 when air is supplied from Ports (A) and (D).

The rod moves stroke 1 when air is supplied from Ports (B) and (D).

The rod moves stroke 2 when air is supplied from Ports (A) and (C).

The rod moves stroke 1 and stroke 2 when air is supplied from Ports (B) and (C).

Inner Construction and Major Parts

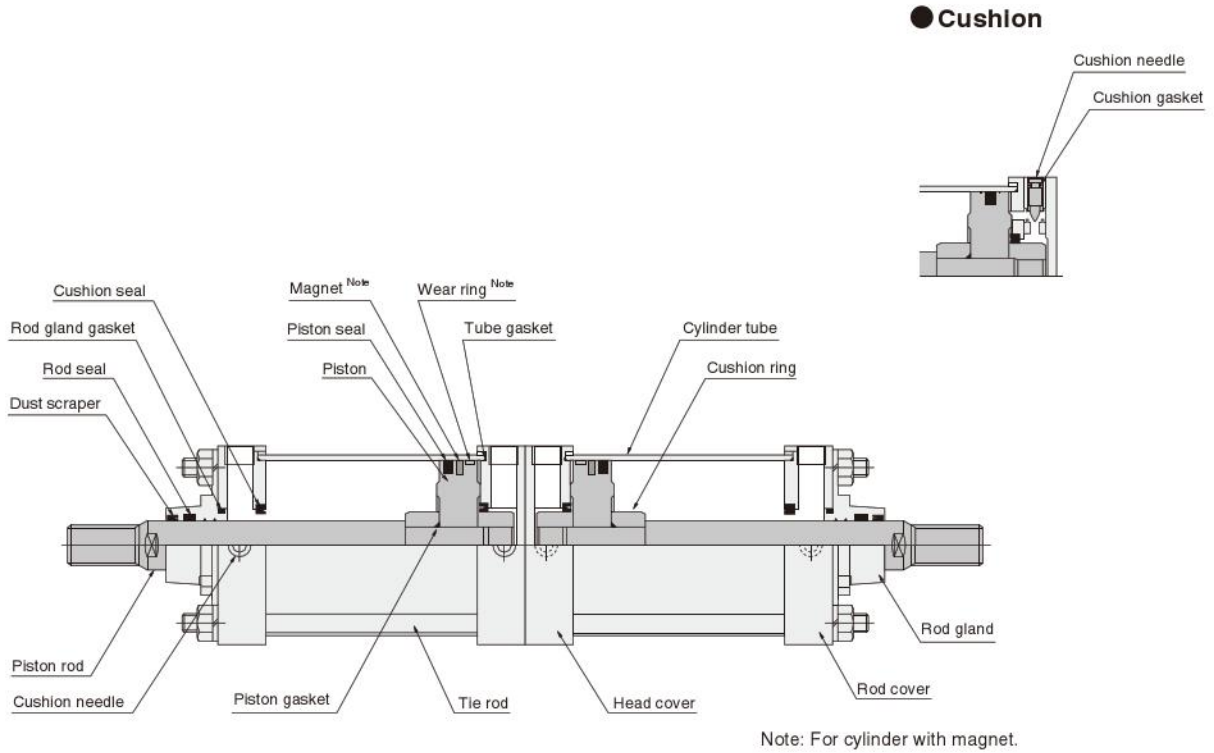

Major Parts and Materials

Parts	Bore size mm	125	140	160	180	200
Cylinder tube	Standard cylinder	Steel pipe (inside: hard chrome plated, outside: silver metallic painted)				
	Cylinder with magnet	Aluminum alloy (hard anodized)			—	
Piston		Cast iron <small>Note</small>				
Piston rod		Steel (hard chrome plated) (-RS : SUS)				
Cushion ring		Mild steel (zinc plated)				
Rod cover		Mild steel (black oxide)				
Head cover						
Tie rod		Mild steel (zinc plated)				
Rod gland		Aluminum alloy (hard anodized)				
Wear ring		Plastic			—	

Parts	Bore size mm	125	140	160	180	200
Magnet		Rubber magnet			—	
Seal		Synthetic rubber (NBR)				
Foot mounting bracket		Mild steel (painted)				
Flange mounting bracket		Cast iron (manganese treated)				
Trunnion mounting bracket		Cast iron (manganese treated)				
Bellows		Nylon tarpaulin				
I type knuckle		Mild steel (alkali coloring)				
Y type knuckle		Cast iron (manganese treated)				
Pin		Steel (zinc plated)				

Note: The cylinder with magnet is aluminum alloy.

Seals

Item	Dust scraper★	Rod seal★	Rod gland gasket	Cylinder tube gasket★	Cushion seal	Piston seal★	Piston gasket	Cushion gasket	
Bore size mm	Quantity	2	2	2	4	4	2	2	4
125	SDR-35	PNY-35	G-50	S-120	PCS-50	PWP-125N	G-25	P-7	
140	SDR-35	PNY-35	G-50	S-135	PCS-50	PWP-140N	G-25	P-7	
160	SDR-40	PNY-40	G-50	#160	PCS-50	PWP-160N	G-25	P-7	
180	SDR-45	PNY-45	G-60	#180	PCS-60	PSD-180	G-35	P-7	
200	SDR-50	PNY-50	G-60	#200	PCS-60	PSD-200	G-35	P-7	

Remark: Items marked with a star (★) are available as repair kits. The order code is the **SRK-NSD** [Bore size].

Note that the contents of a repair kit is 1 dust scraper, 1 rod seal, 1 piston seal, and 2 cylinder tube gaskets.

Note, however, that the repair kits with bore size of 125mm and 140mm cannot be used with SD cylinders manufactured prior to April 6, 2000 (because the piston rod diameters have been changed). For details, see p.543.

Dimensions of Basic Type (mm)

KA0SDW Bore size X Stroke 1 X Stroke 2

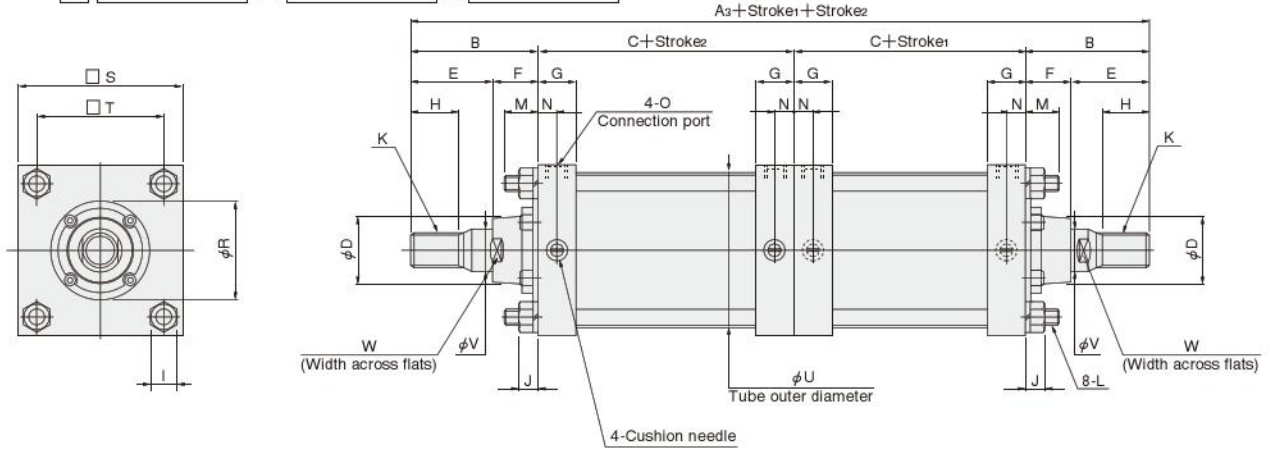

Bore mm [in.]	Code	A ₃	B	C	D	E	F	G	H	I	J	K
125 [4.921]		416	110	98	60	72	38	35	50	22	14.5	M30×1.5
140 [5.512]		416	110	98	60	72	38	35	50	22	14.5	M30×1.5
160 [6.299]		452	120	106	60	82	38	39	56	24	17	M36×1.5
180 [7.087]		492	135	111	70	95	40	39	63	27	19.6	M40×1.5
200 [7.874]		492	135	111	70	95	40	39	63	30	21.1	M45×1.5

Bore mm [in.]	Code	L	M	N	O	R	S	T	U	V	W
125 [4.921]		M14×1.5	27	16	Rc1/2	90 ^{-0.1} _{-0.2}	145	115	134(135)	35	32
140 [5.512]		M14×1.5	27	16	Rc1/2	90 ^{-0.1} _{-0.2}	160	128	150	35	32
160 [6.299]		M16×1.5	30.5	18.5	Rc3/4	90 ^{-0.1} _{-0.2}	182	144	170	40	36
180 [7.087]		M18×1.5	35	18.5	Rc3/4	115 ^{-0.1} _{-0.2}	204	162	193	45	41
200 [7.874]		M20×1.5	35	18.5	Rc3/4	115 ^{-0.1} _{-0.2}	226	182	213	50	46

Figures in parentheses () are for cylinders with magnets.

Dimensions of Foot Mounting Type (mm)

KA1SDW Bore size X Stroke 1 X Stroke 2

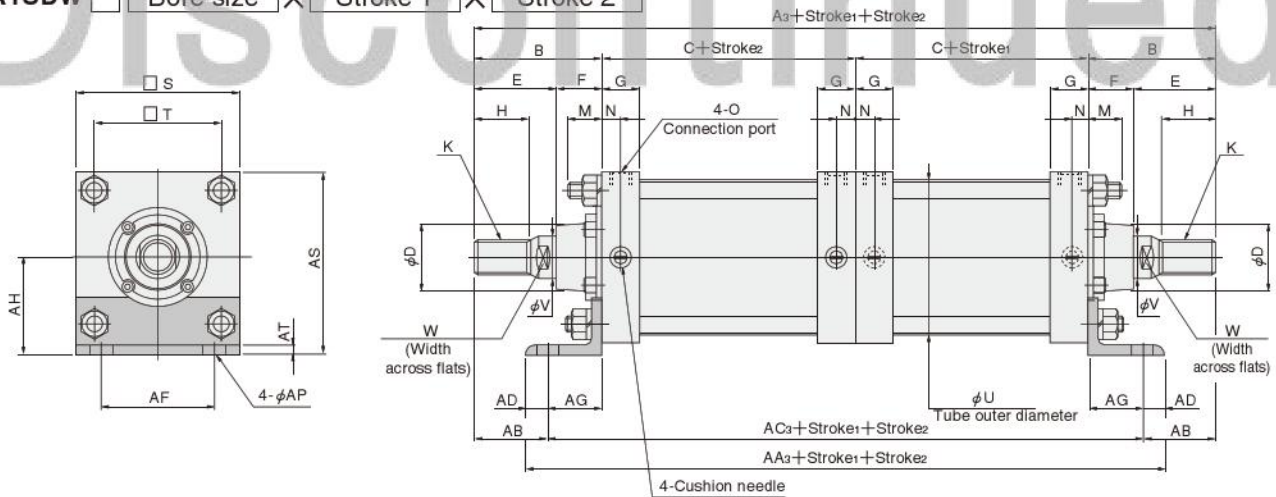

Bore mm [in.]	Code	A ₃	B	C	D	E	F	G	H	K	M	N	O	S	T
125 [4.921]		416	110	98	60	72	38	35	50	M30×1.5	27	16	Rc1/2	145	115
140 [5.512]		416	110	98	60	72	38	35	50	M30×1.5	27	16	Rc1/2	160	128
160 [6.299]		452	120	106	60	82	38	39	56	M36×1.5	30.5	18.5	Rc3/4	182	144
180 [7.087]		492	135	111	70	95	40	39	63	M40×1.5	35	18.5	Rc3/4	204	162
200 [7.874]		492	135	111	70	95	40	39	63	M45×1.5	35	18.5	Rc3/4	226	182

Bore mm [in.]	Code	U	V	W	AA ₃	AB	AC ₃	AD	AF	AG	AH	AP	AS	AT
125 [4.921]		134(135)	35	32	326	65	286	20	100	45	85	19	157.5	8
140 [5.512]		150	35	32	346	65	286	30	112	45	100	19	180	9
160 [6.299]		170	40	36	362	70	312	25	118	50	108	19	197	9
180 [7.087]		193	45	41	402	75	342	30	132	60	125	24	227	10
200 [7.874]		213	50	46	402	75	342	30	150	60	132	24	245	10

Figures in parentheses () are for cylinders with magnets.

SD STROKE ADJUSTING CYLINDERS

Push Side Stroke Adjusting Type,
Pull Side Stroke Adjusting Type



SD CYLINDERS

Symbols

● Push side stroke adjusting type

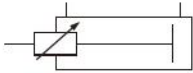

● Pull side stroke adjusting type

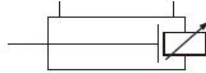

Specifications

Item	Bore size mm [in.]	125 [4.921]	140 [5.512]	160 [6.299]	180 [7.087] ^{Note}	200 [7.874] ^{Note}
Operation type		Double acting type				
Media		Air				
Mounting type		Basic type, Foot type, Rod side flange type, Head side flange type, Trunnion type				
Stroke adjusting range	mm [in.]	-50~0 [-1.969~0] (To the specification stroke)				
Operating pressure range	MPa [psi.]	0.05~0.97 [7~141]				
Proof pressure	MPa [psi.]	1.47 [213]				
Operating temperature range	°C [°F]	0~60 [32~140]				
Operating speed range	mm/s [in./sec.]	30~500 [1.2~19.7]				
Cushion stroke	mm [in.]	26 [1.024]			28 [1.102]	
Lubrication		Not required				
Port size	Rc	1/2			3/4	

Note: Cylinder with magnet is not available. Not available with pull side stroke adjusting type in ϕ 180 and ϕ 200.

Remark: When adjusting the stroke, the cushion will be a rubber bumper on one side.

Bore Size and Stroke

● Push side stroke adjusting type

	Bore size	Standard strokes	Maximum available stroke
Standard cylinder	125	0~1000	1000
	140		
	160		
	180	0~990	990
	200		
Cylinder with magnet	125	0~1000	1000
	140		
	160		

Remarks: 1. Stroke tolerance: Strokes of 250mm or less: ${}^{+1.0}_{0} [{}^{+0.039in.}_{0}]$, strokes of 251~1000mm: ${}^{+1.4}_{0} [{}^{+0.055in.}_{0}]$

2. Minimum available stroke of trunnion mounting type is ϕ 125: 22mm, ϕ 140: 27mm, ϕ 160: 32mm, ϕ 180: 29mm, and ϕ 200: 34mm.

● Pull side stroke adjusting type

	Bore size	Standard strokes	Maximum available stroke
Standard cylinder	125	0~1000	1000
	140		
	160		
Cylinder with magnet	125	0~1000	1000
	140		
	160		

Remarks: 1. Stroke tolerance: Strokes of 250mm or less: ${}^{+1.0}_{0} [{}^{+0.039in.}_{0}]$, strokes of 251~1000mm: ${}^{+1.4}_{0} [{}^{+0.055in.}_{0}]$

2. Minimum available stroke of trunnion mounting type is ϕ 125: 22mm, ϕ 140: 27mm, ϕ 160: 32mm, ϕ 180: 29mm, and ϕ 200: 34mm.

The strokes listed below or larger should be included with class 2 pressure vessels.

Bore size	Cylinder stroke
125	3640
140	2615
160	1990
180	1573
200	1000

Order Codes

KA SD **125×100**

Bore size
×
Stroke

Sensor specification
Blank — Standard cylinder
S — Cylinder with magnet
(Not available in φ 180 and φ 200.)

Cylinder specification
P — Push side stroke adjusting type
JP — Push side stroke adjusting type with bellows
PY — Push side stroke adjusting type with heavy duty dust scraper (Available as a special)
● For delivery, consult us.
E — Pull side stroke adjusting type
EJ — Pull side stroke adjusting type with bellows
EY — Pull side stroke adjusting type with heavy duty dust scraper (Available as a special)
● For delivery, consult us.
(Not available with pull side stroke adjusting type in φ 180 and φ 200.)

Rod end nut
Blank — No nut
N1 — With 1 nut
N2 — With 2 nuts

Piston rod specification
Blank — Standard type
RS — SUS rod
(Available as a special.
For delivery, consult us.)

Lead wire length
A — 1000mm [39in.]
B — 3000mm [118in.]
:
:

Number of sensor switches
1 — With 1 sensor switch
2 — With 2 sensor switches
3 — With 3 sensor switches
:
:

Sensor switch (For the cylinder with magnet)
ZC130 — 2-lead wire Solid state type with indicator lamp DC10~28V
ZC153 — 3-lead wire Solid state type with indicator lamp DC4.5~28V
CS5T — 2-lead wire Reed switch type without indicator lamp DC5~28V AC85~115V
CS11T — 2-lead wire Reed switch type with indicator lamp DC10~28V
● For details of sensor switches, see p.1544.

Mounting type
0 — Basic type
1 — Foot mounting type
3 — Rod side flange mounting type
5 — Head side flange mounting type
11 — Trunnion mounting type

Rod end accessory
Blank — No rod end accessory
Y — With Y type knuckle (with pin)
I — With I type knuckle

Mass

● Push side stroke adjusting type

Bore size mm [in.]	Zero stroke mass				Additional mass for each 1mm [0.0394in.] stroke	Mass of 1 sensor switch (With holder) ^{Note}		Additional mass		
	Basic type	Foot mounting type	Flange mounting type	Trunnion mounting type		ZC□□□	CS□T	Nut	Y type knuckle (With pin)	I type knuckle
125 [4.921]	17.0 [37.5] (15.4 [34.0])	18.7 [41.2] (17.1 [37.7])	19.5 [43.0] (17.9 [39.5])	20.4 [45.0] (18.8 [41.5])	0.0336 [0.0741] (0.0247 [0.0545])	0.07 [0.15]	0.07 [0.15]	0.2 [0.4]	1.5 [3.3]	1.5 [3.3]
140 [5.512]	20.0 [44.1] (18.0 [39.7])	22.6 [49.8] (20.6 [45.4])	24.6 [54.2] (22.6 [49.8])	24.5 [54.0] (22.5 [49.6])	0.0371 [0.0818] (0.0254 [0.0560])			0.2 [0.4]	1.6 [3.5]	1.9 [4.2]
160 [6.299]	27.5 [60.6] (25.0 [55.1])	30.4 [67.0] (27.9 [61.5])	33.3 [73.4] (30.8 [67.9])	34.3 [75.6] (31.8 [70.1])	0.0451 [0.0994] (0.0318 [0.0701])	—	—	0.3 [0.7]	2.1 [4.6]	2.8 [6.2]
180 [7.087]	36.2 [79.8]	40.6 [89.5]	45.4 [100.1]	44.5 [98.1]	0.0620 [0.1367]			0.4 [0.9]	3.9 [8.6]	3.9 [8.6]
200 [7.874]	45.2 [99.7]	50.0 [110.3]	56.0 [123.5]	56.8 [125.2]	0.0727 [0.1603]	0.6 [1.3]	3.7 [8.2]	4.0 [8.8]		

Note: For lead wire length A (1000mm [39in.]).

Remark: Figures in parentheses () are for cylinders with magnets.

Calculation example: For standard cylinder, foot mounting type, with bore size of 140mm, stroke of 100mm, $22.6 + (0.0371 \times 100) = 26.31\text{kg}$ [58.01lb.]

● Pull side stroke adjusting type

Bore size mm [in.]	Zero stroke mass				Additional mass for each 1mm [0.0394in.] stroke	Mass of 1 sensor switch (With holder) ^{Note}		Additional mass		
	Basic type	Foot mounting type	Flange mounting type	Trunnion mounting type		ZC□□□	CS□T	Nut	Y type knuckle (With pin)	I type knuckle
125 [4.921]	17.0 [37.5] (15.4 [34.0])	18.7 [41.2] (17.1 [37.7])	19.5 [43.0] (17.9 [39.5])	20.4 [45.0] (18.8 [41.5])	0.0256 [0.0564] (0.0167 [0.0368])	0.07 [0.15]	0.07 [0.15]	0.2 [0.4]	1.5 [3.3]	1.5 [3.3]
140 [5.512]	20.1 [44.3] (18.1 [39.9])	22.7 [50.1] (20.7 [45.6])	24.7 [54.5] (22.7 [50.0])	24.6 [54.2] (22.6 [49.8])	0.0291 [0.0642] (0.0174 [0.0384])			0.2 [0.4]	1.6 [3.5]	1.9 [4.2]
160 [6.299]	27.2 [60.0] (24.7 [54.5])	30.1 [66.4] (27.6 [60.9])	33.0 [72.8] (30.5 [67.3])	34.0 [75.0] (31.5 [69.5])	0.0352 [0.0776] (0.0219 [0.0483])	0.3 [0.7]	2.1 [4.6]	2.8 [6.2]		

Note: For lead wire length A (1000mm [39in.]).

Remark: Figures in parentheses () are for cylinders with magnets.

Calculation example: For standard cylinder, foot mounting type, with bore size of 140mm, stroke of 100mm, $22.7 + (0.0291 \times 100) = 25.61\text{kg}$ [56.47lb.]

Inner Construction and Major Parts

● Push side stroke adjusting type

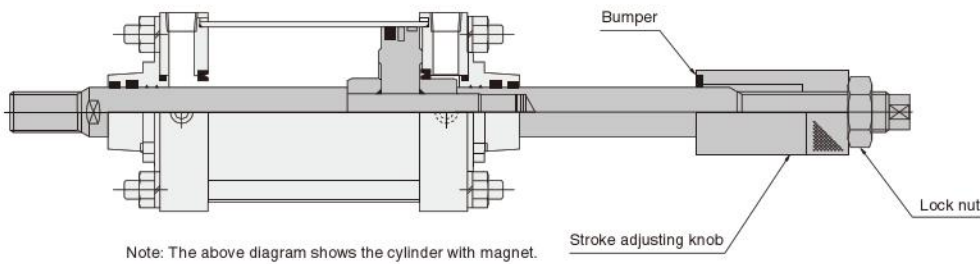

● Cushion

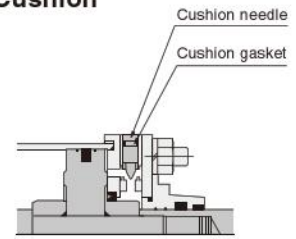

● Pull side stroke adjusting type

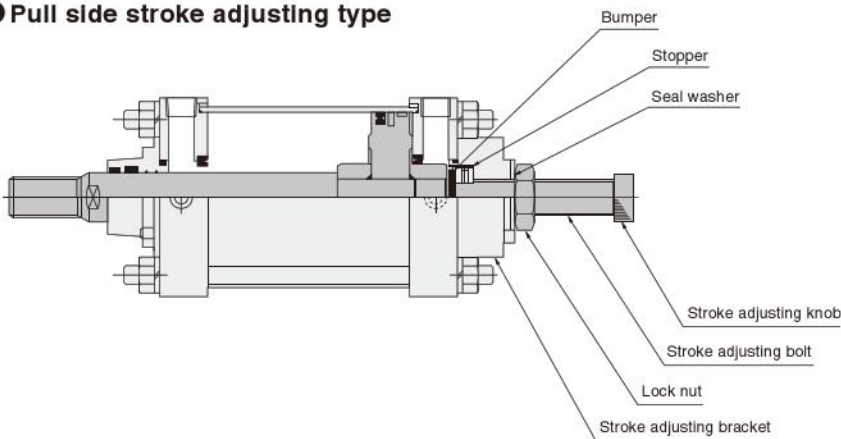

● Cushion

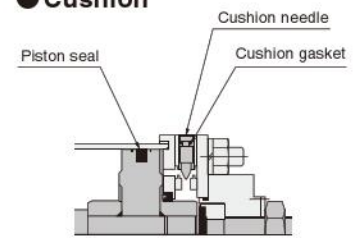

● Stroke adjustment

To adjust the stroke, turn the stroke adjusting knob. After adjustment, secure it in place with a lock nut. When mounting the sensor switch, move sensor switch mounting location as the length of the adjusted stroke.

Major Parts and Materials

Parts	Bore size mm	125	140	160	180	200
Cylinder tube	Standard cylinder	Steel pipe (inside: hard chrome plated, outside: silver metallic painted)				
	Cylinder with magnet	Aluminum alloy (hard anodized)		—		
Piston		Cast iron ^{Note}				
Piston rod		Steel (hard chrome plated) (-RS : SUS)				
Cushion ring		Mild steel (zinc plated)				
Rod cover		Mild steel (black oxide)				
Tie rod		Mild steel (zinc plated)				
Rod gland		Aluminum alloy (hard anodized)				
Wear ring		Plastic	—			
Magnet		Rubber magnet		—		
Seal		Synthetic rubber (NBR)				
Stroke adjusting knob		Aluminum alloy (anodized)				

Parts	Bore size mm	125	140	160	180	200
Stroke adjusting bolt		Steel (zinc plated)		—		
Stroke adjusting bracket		Mild steel (painted)		—		
Stopper		Mild steel (zinc plated)		—		
Bumper		Synthetic rubber (urethane rubber)				
Foot mounting bracket		Steel (painted)				
Flange mounting bracket		Cast iron (manganese treated)				
Trunnion mounting bracket		Cast iron (manganese treated)				
Bellows		Nylon tarpaulin				
I type knuckle		Mild steel (alkali coloring)				
Y type knuckle		Cast iron (manganese treated)				
Pin		Steel (zinc plated)				

Note: The cylinder with magnet is aluminum alloy.

Seals

Item	Dust scraper★	Rod seal★	Rod gland gasket	Cylinder tube gasket★	Cushion seal	Piston seal★	Piston gasket	Cushion gasket
Quantity	2(1)	2(1)	2	2	2	1	2(1)	2
Bore size mm								
125	SDR-35	PNY-35	G-50	S-120	PCS-50	PWP-125N	G-25	P-7
140	SDR-35	PNY-35	G-50	S-135	PCS-50	PWP-140N	G-25	P-7
160	SDR-40	PNY-40	G-50	#160	PCS-50	PWP-160N	G-25	P-7
180	SDR-45	PNY-45	G-60	#180	PCS-60	PSD-180	G-35	P-7
200	SDR-50	PNY-50	G-60	#200	PCS-60	PSD-200	G-35	P-7

Remarks: 1. Figures in parentheses () are for pull side stroke adjusting type.

2. Items marked with a star (★) are available as repair kits. The order code is the **SRK-NSD** [Bore size].

Note that the contents of a repair kit is 1 dust scraper, 1 rod seal, 1 piston seal, and 2 cylinder tube gaskets.

Note, however, that the repair kits with bore size of 125mm and 140mm cannot be used with SD cylinders manufactured prior to April 6, 2000 (because the piston rod diameters have been changed). For details, see p.543.

Dimensions of Push Side Stroke Adjusting, Basic Type (mm)

KA0SDP Bore size Stroke

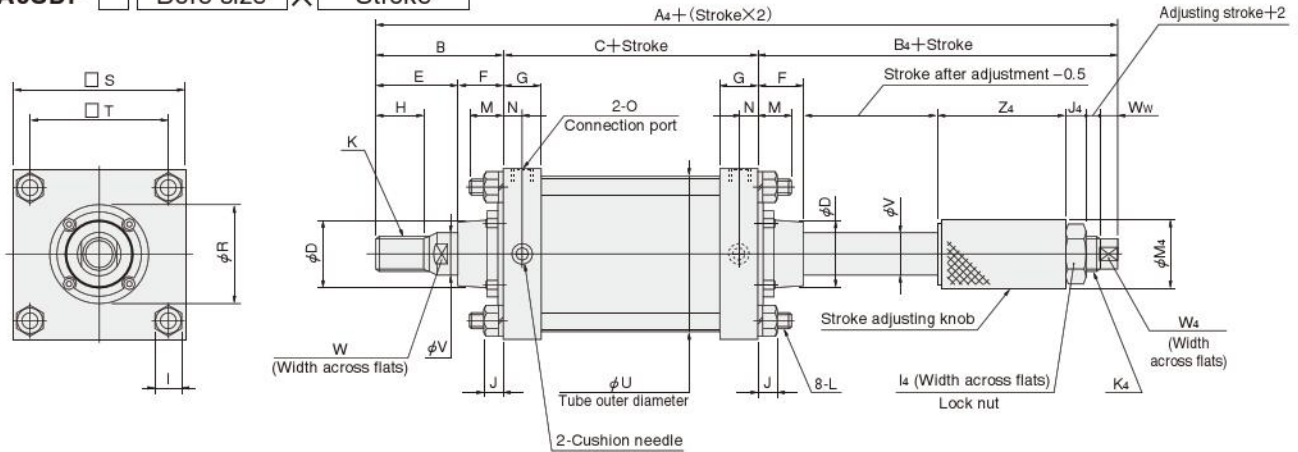

Bore mm [in.]	Code	A ₄	B	B ₄	C	D	E	F	G	H	I	I ₄	J	J ₄	K	K ₄
125 [4.921]		393	110	185	98	60	72	38	35	50	22	46	14.5	18	M30×1.5	M30×1.5
140 [5.512]		393	110	185	98	60	72	38	35	50	22	46	14.5	18	M30×1.5	M30×1.5
160 [6.299]		411	120	185	106	60	82	38	39	56	24	46	17	18	M36×1.5	M30×1.5
180 [7.087]		456	135	210	111	70	95	40	39	63	27	60	19.6	23	M40×1.5	M40×1.5
200 [7.874]		456	135	210	111	70	95	40	39	63	30	60	21.1	23	M45×1.5	M40×1.5

Bore mm [in.]	Code	L	M	M ₄	N	O	R	S	T	U	V	W	W ₄	W _w	Z ₄
125 [4.921]		M14×1.5	27	65	16	Rc1/2	90 ^{-0.1} _{-0.2}	145	115	134(135)	35	32	22	15	112.5
140 [5.512]		M14×1.5	27	65	16	Rc1/2	90 ^{-0.1} _{-0.2}	160	128	150	35	32	22	15	112.5
160 [6.299]		M16×1.5	30.5	65	18.5	Rc3/4	90 ^{-0.1} _{-0.2}	182	144	170	40	36	22	15	112.5
180 [7.087]		M18×1.5	35	75	18.5	Rc3/4	115 ^{-0.1} _{-0.2}	204	162	193	45	41	27	20	125.5
200 [7.874]		M20×1.5	35	75	18.5	Rc3/4	115 ^{-0.1} _{-0.2}	226	182	213	50	46	27	20	125.5

Figures in parentheses () are for cylinders with magnets.

Dimensions of Push Side Stroke Adjusting, Foot Mounting Type (mm)

KA1SDP Bore size Stroke

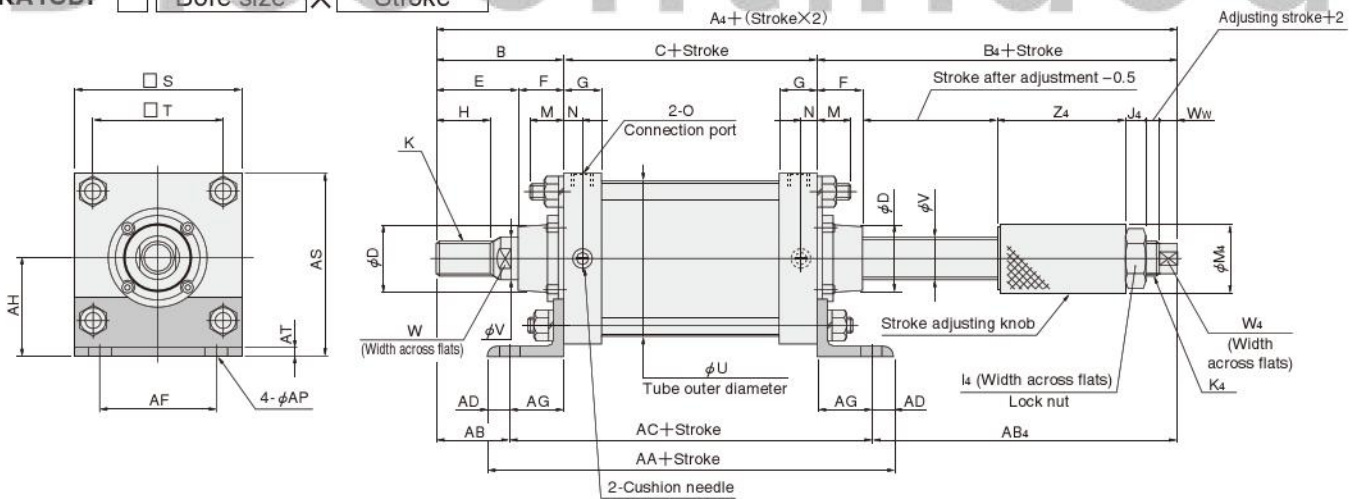

Bore mm [in.]	Code	A ₄	B	B ₄	C	D	E	F	G	H	I ₄	J ₄	K	K ₄	L	M	M ₄	N
125 [4.921]		393	110	185	98	60	72	38	35	50	46	18	M30×1.5	M30×1.5	M14×1.5	27	65	16
140 [5.512]		393	110	185	98	60	72	38	35	50	46	18	M30×1.5	M30×1.5	M14×1.5	27	65	16
160 [6.299]		411	120	185	106	60	82	38	39	56	46	18	M36×1.5	M30×1.5	M16×1.5	30.5	65	18.5
180 [7.087]		456	135	210	111	70	95	40	39	63	60	23	M40×1.5	M40×1.5	M18×1.5	35	75	18.5
200 [7.874]		456	135	210	111	70	95	40	39	63	60	23	M45×1.5	M40×1.5	M20×1.5	35	75	18.5

Bore mm [in.]	Code	O	S	T	U	V	W	W ₄	W _w	Z ₄	AA	AB	AB ₄	AC	AD	AF	AG	AH	AP	AS	AT
125 [4.921]		Rc1/2	145	115	134(135)	35	32	22	15	112.5	228	65	140	188	20	100	45	85	19	157.5	8
140 [5.512]		Rc1/2	160	128	150	35	32	22	15	112.5	248	65	140	188	30	112	45	100	19	180	9
160 [6.299]		Rc3/4	182	144	170	40	36	22	15	112.5	256	70	135	206	25	118	50	106	19	197	9
180 [7.087]		Rc3/4	204	162	193	45	41	27	20	125.5	291	75	150	231	30	132	60	125	24	227	10
200 [7.874]		Rc3/4	226	182	213	50	46	27	20	125.5	291	75	150	231	30	150	60	132	24	245	10

Figures in parentheses () are for cylinders with magnets.

Dimensions of Push Side Stroke Adjusting, Rod Side Flange Mounting Type (mm)

KA3SDP Bore size × Stroke

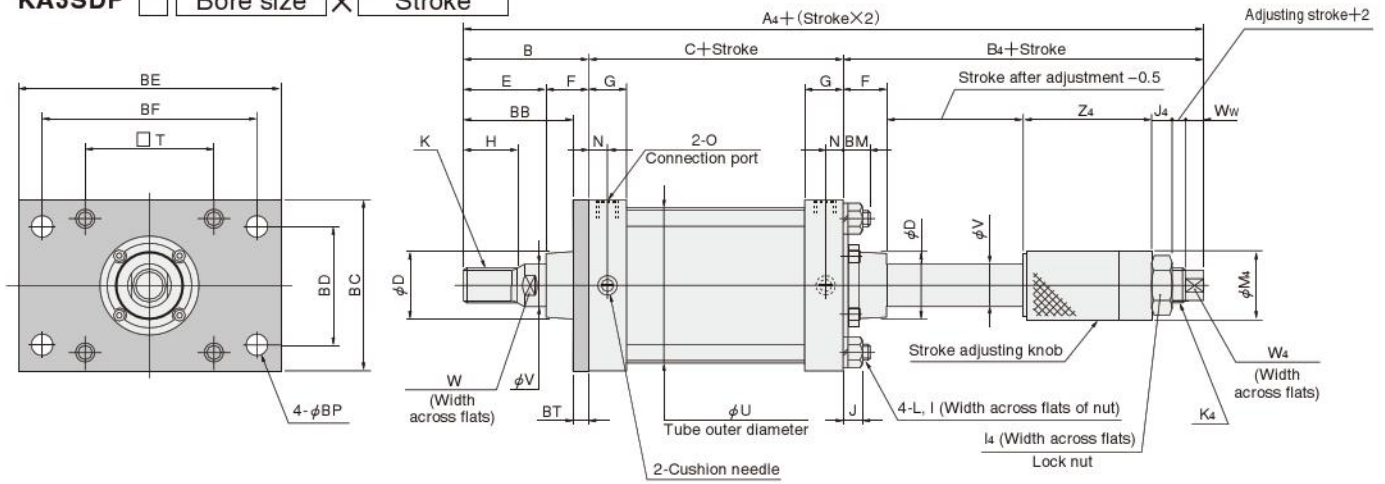

Bore mm [in.]	Code	A4	B	B4	C	D	E	F	G	H	I	I4	J	J4	K	K4	L
125	[4.921]	393	110	185	98	60	72	38	35	50	22	46	14.5	18	M30×1.5	M30×1.5	M14×1.5
140	[5.512]	393	110	185	98	60	72	38	35	50	22	46	14.5	18	M30×1.5	M30×1.5	M14×1.5
160	[6.299]	411	120	185	106	60	82	38	39	56	24	46	17	18	M36×1.5	M30×1.5	M16×1.5
180	[7.087]	456	135	210	111	70	95	40	39	63	27	60	19.6	23	M40×1.5	M40×1.5	M18×1.5
200	[7.874]	456	135	210	111	70	95	40	39	63	30	60	21.1	23	M45×1.5	M40×1.5	M20×1.5

Bore mm [in.]	Code	M4	N	O	T	U	V	W	W4	Ww	Z4	BB	BC	BD	BE	BF	BM	BP	BT
125	[4.921]	65	16	Rc1/2	115	134(135)	35	32	22	15	112.5	96	145	100	230	190	23	19	14
140	[5.512]	65	16	Rc1/2	128	150	35	32	22	15	112.5	90	160	112	255	212	17	19	20
160	[6.299]	65	18.5	Rc3/4	144	170	40	36	22	15	112.5	100	182	118	275	236	20	19	20
180	[7.087]	75	18.5	Rc3/4	162	193	45	41	27	20	125.5	110	204	132	320	265	23	24	25
200	[7.874]	75	18.5	Rc3/4	182	213	50	46	27	20	125.5	110	226	150	335	280	25	24	25

Figures in parentheses () are for cylinders with magnets.

Dimensions of Push Side Stroke Adjusting, Head Side Flange Mounting Type (mm)

KA5SDP Bore size × Stroke

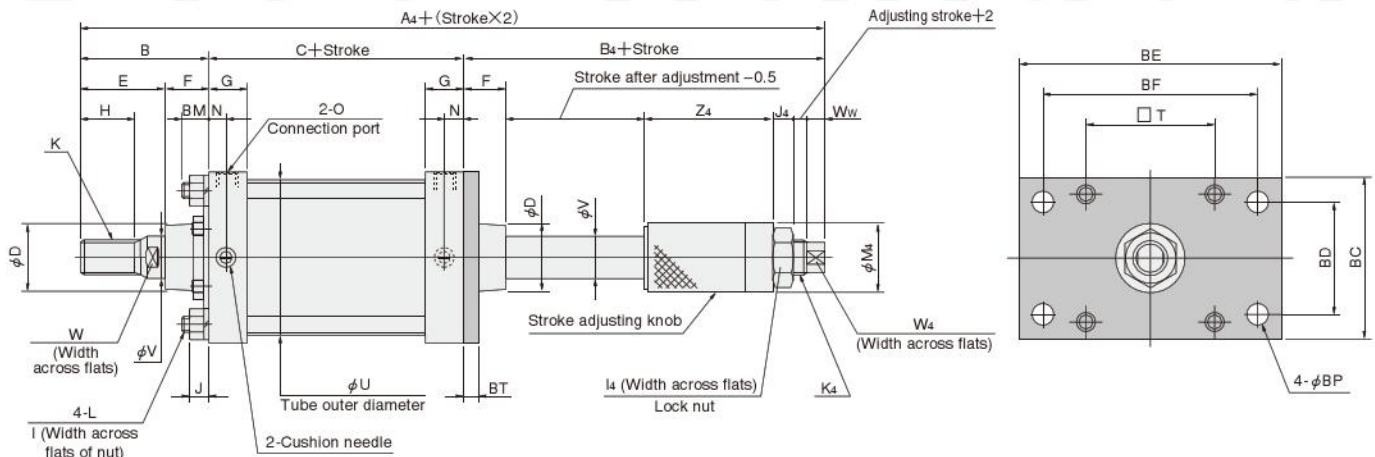

Bore mm [in.]	Code	A4	B	B4	C	D	E	F	G	H	I	I4	J	J4	K	K4	L
125	[4.921]	393	110	185	98	60	72	38	35	50	22	46	14.5	18	M30×1.5	M30×1.5	M14×1.5
140	[5.512]	393	110	185	98	60	72	38	35	50	22	46	14.5	18	M30×1.5	M30×1.5	M14×1.5
160	[6.299]	411	120	185	106	60	82	38	39	56	24	46	17	18	M36×1.5	M30×1.5	M16×1.5
180	[7.087]	456	135	210	111	70	95	40	39	63	27	60	19.6	23	M40×1.5	M40×1.5	M18×1.5
200	[7.874]	456	135	210	111	70	95	40	39	63	30	60	21.1	23	M45×1.5	M40×1.5	M20×1.5

Bore mm [in.]	Code	M4	N	O	T	U	V	W	W4	Ww	Z4	BC	BD	BE	BF	BM	BP	BT
125	[4.921]	65	16	Rc1/2	115	134(135)	35	32	22	15	112.5	145	100	230	190	23	19	14
140	[5.512]	65	16	Rc1/2	128	150	35	32	22	15	112.5	160	112	255	212	17	19	20
160	[6.299]	65	18.5	Rc3/4	144	170	40	36	22	15	112.5	182	118	275	236	20	19	20
180	[7.087]	75	18.5	Rc3/4	162	193	45	41	27	20	125.5	204	132	320	265	23	24	25
200	[7.874]	75	18.5	Rc3/4	182	213	50	46	27	20	125.5	226	150	335	280	25	24	25

Figures in parentheses () are for cylinders with magnets.

Dimensions of Push Side Stroke Adjusting, Trunnion Mounting Type (mm)

KA11SDP Bore size × Stroke

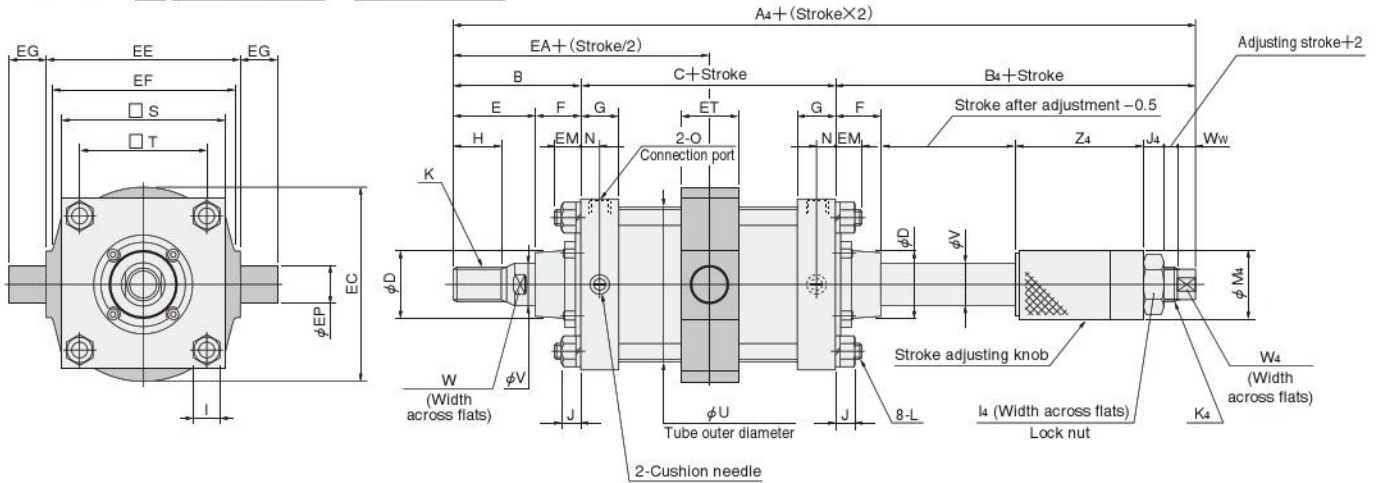

Bore max [in.]	Code	A ₄	B	B ₄	C	D	E	F	G	H	I	I ₄	J	J ₄	K	K ₄	L	M ₄
	125 [4.921]	393	110	185	98	60	72	38	35	50	22	46	14.5	18	M30×1.5	M30×1.5	M14×1.5	65
	140 [5.512]	393	110	185	98	60	72	38	35	50	22	46	14.5	18	M30×1.5	M30×1.5	M14×1.5	65
	160 [6.299]	411	120	185	106	60	82	38	39	56	24	46	17	18	M36×1.5	M30×1.5	M16×1.5	65
	180 [7.087]	456	135	210	111	70	95	40	39	63	27	60	19.6	23	M40×1.5	M40×1.5	M18×1.5	75
	200 [7.874]	456	135	210	111	70	95	40	39	63	30	60	21.1	23	M45×1.5	M40×1.5	M20×1.5	75

Bore max [in.]	Code	N	O	S	T	U	V	W	W ₄	W _w	Z ₄	EA	EC	EE	EF	EG	EM	EP	ET
	125 [4.921]	16	Rc1/2	145	115	134(135)	35	32	22	15	112.5	159	164	170 ^{-0.1} _{-0.4}	160	32	18	32 ^{-0.050} _{-0.089}	50
	140 [5.512]	16	Rc1/2	160	128	150	35	32	22	15	112.5	159	184	190 ^{-0.1} _{-0.4}	180	36	18	36 ^{-0.050} _{-0.089}	55
	160 [6.299]	18.5	Rc3/4	182	144	170	40	36	22	15	112.5	173	208	212 ^{-0.1} _{-0.4}	200	40	19.5	40 ^{-0.050} _{-0.089}	60
	180 [7.087]	18.5	Rc3/4	204	162	193	45	41	27	20	125.5	190.5	225	236 ^{-0.1} _{-0.4}	225	45	23.5	45 ^{-0.050} _{-0.089}	62
	200 [7.874]	18.5	Rc3/4	226	182	213	50	46	27	20	125.5	190.5	255	265 ^{-0.1} _{-0.4}	255	45	24.5	45 ^{-0.050} _{-0.089}	67

Figures in parentheses () are for cylinders with magnets.

Dimensions of Pull Side Stroke Adjusting, Basic Type (mm)

KA0SDE Bore size × Stroke

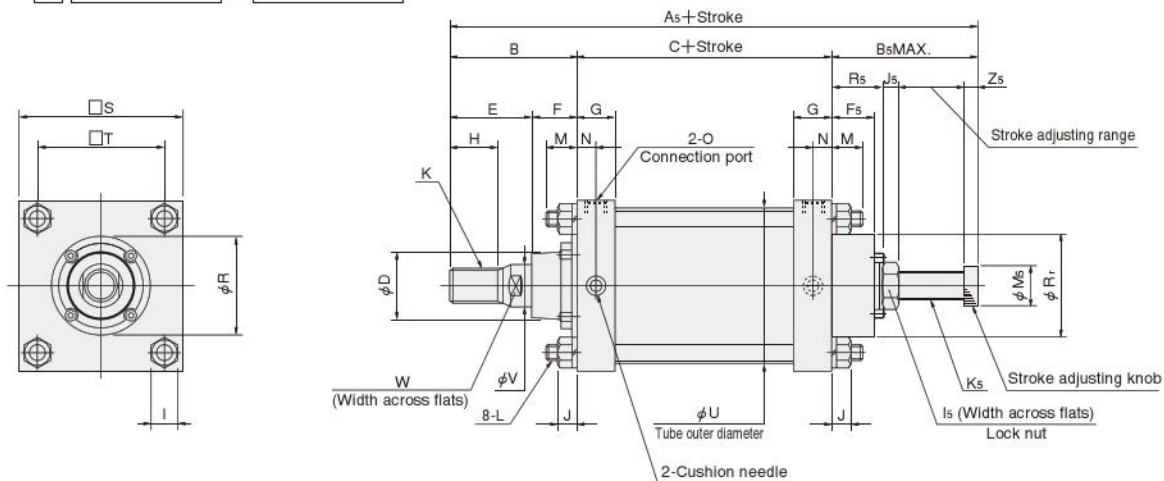

Bore mm [in.]	Code	A ₅	B	B ₅	C	D	E	F	F ₅	G	H	I	I ₅	J	J ₅	K	K ₅
125 [4.921]		336	110	128	98	60	72	38	35	35	50	22	36	14.5	14	M30×1.5	M24×1.5
140 [5.512]		336	110	128	98	60	72	38	35	35	50	22	36	14.5	14	M30×1.5	M24×1.5
160 [6.299]		350	120	124	106	60	82	38	35	39	56	24	36	17	14	M36×1.5	M24×1.5

Bore mm [in.]	Code	L	M	M ₅	N	O	R	R ₅	R _r	S	T	U	V	W	Z ₅
125 [4.921]		M14×1.5	27	35	16	Rc1/2	90 ^{-0.1} _{-0.2}	43	90 ^{-0.1} _{-0.2}	145	115	134(135)	35	32	12
140 [5.512]		M14×1.5	27	35	16	Rc1/2	90 ^{-0.1} _{-0.2}	43	90 ^{-0.1} _{-0.2}	160	128	150	35	32	12
160 [6.299]		M16×1.5	30.5	35	18.5	Rc3/4	90 ^{-0.1} _{-0.2}	43	90 ^{-0.1} _{-0.2}	182	144	170	40	36	12

Figures in parentheses () are for cylinders with magnets.

Dimensions of Pull Side Stroke Adjusting, Foot Mounting Type (mm)

KA1SDE Bore size × Stroke

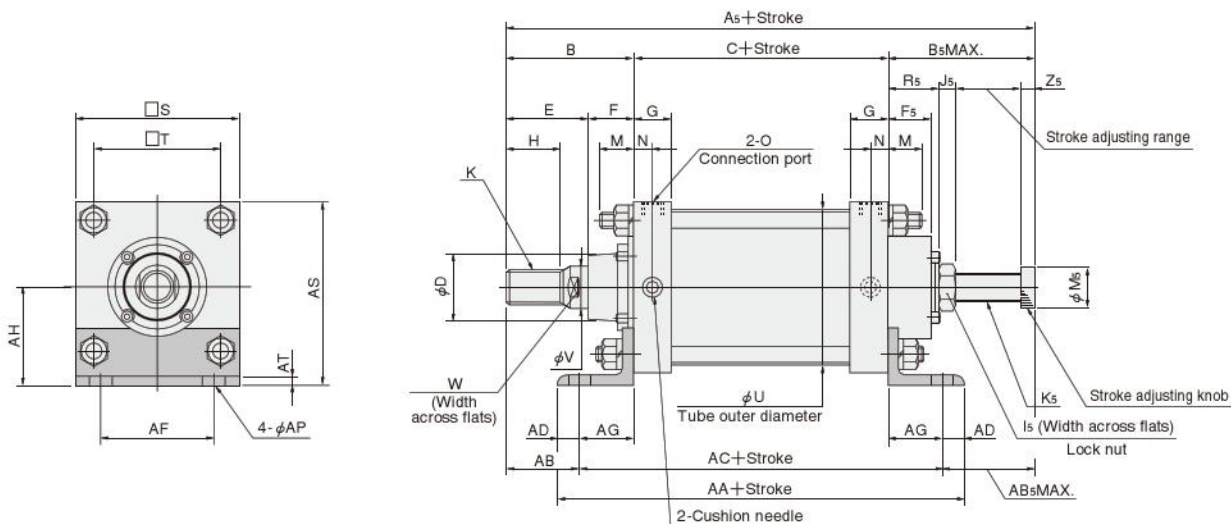

Bore mm [in.]	Code	A ₅	B	B ₅	C	D	E	F	F ₅	G	H	I ₅	J ₅	K	K ₅	M	M ₅	N
125 [4.921]		336	110	128	98	60	72	38	35	35	50	36	14	M30×1.5	M24×1.5	27	35	16
140 [5.512]		336	110	128	98	60	72	38	35	35	50	36	14	M30×1.5	M24×1.5	27	35	16
160 [6.299]		350	120	124	106	60	82	38	35	39	56	36	14	M36×1.5	M24×1.5	30.5	35	18.5

Bore mm [in.]	Code	O	R ₅	S	T	U	V	W	Z ₅	AA	AB	AB ₅	AC	AD	AF	AG	AH	AP	AS	AT
125 [4.921]		Rc1/2	43	145	115	134(135)	35	32	12	228	65	71	188	20	100	45	85	19	157.5	8
140 [5.512]		Rc1/2	43	160	128	150	35	32	12	248	65	71	188	30	112	45	100	19	180	9
160 [6.299]		Rc3/4	43	182	144	170	40	36	12	256	70	67	206	25	118	50	108	19	197	9

Figures in parentheses () are for cylinders with magnets.

Dimensions of Pull Side Stroke Adjusting, Rod Side Flange Mounting Type (mm)

KA3SDE Bore size Stroke

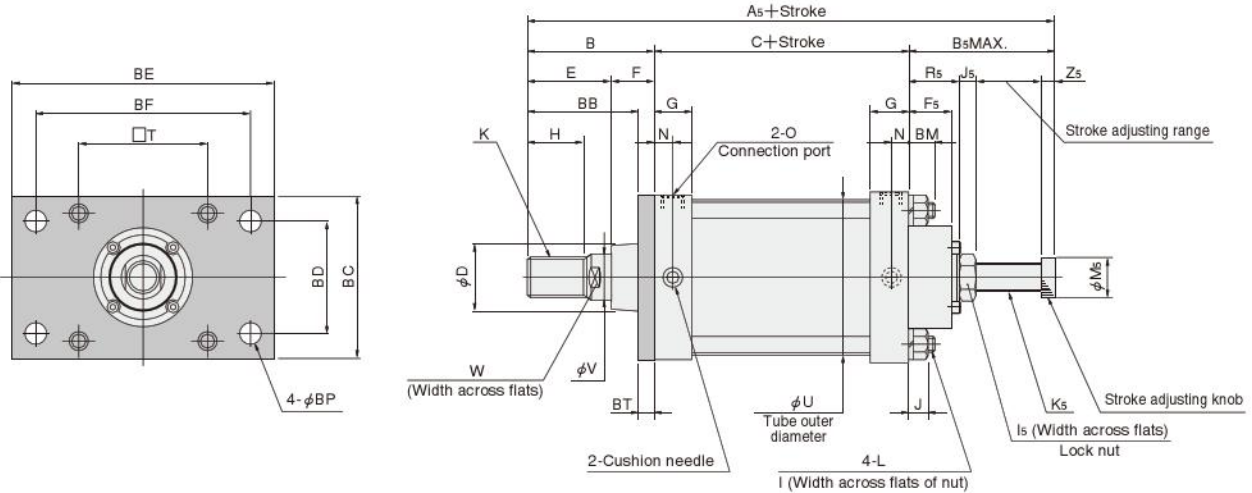

Bore mm [in.]	Code	A _s	B	B _s	C	D	E	F	F _s	G	H	I	I _s	J	J _s	K	K _s	L
125 [4.921]		336	110	128	98	60	72	38	35	35	50	22	36	14.5	14	M30×1.5	M24×1.5	M14×1.5
140 [5.512]		336	110	128	98	60	72	38	35	35	50	22	36	14.5	14	M30×1.5	M24×1.5	M14×1.5
160 [6.299]		350	120	124	106	60	82	38	35	39	56	24	36	17	14	M36×1.5	M24×1.5	M16×1.5

Bore mm [in.]	Code	M _s	N	O	R _s	T	U	V	W	Z _s	BB	BC	BD	BE	BF	BM	BP	BT
125 [4.921]		35	16	Rc1/2	43	115	134(135)	35	32	12	96	145	100	230	190	23	19	14
140 [5.512]		35	16	Rc1/2	43	128	150	35	32	12	90	160	112	255	212	17	19	20
160 [6.299]		35	18.5	Rc3/4	43	144	170	40	36	12	100	182	118	275	236	20	19	20

Figures in parentheses () are for cylinders with magnets.

Dimension of Pull Side Stroke Adjusting, Head Side Flange Mounting Type (mm)

KA5SDE Bore size Stroke

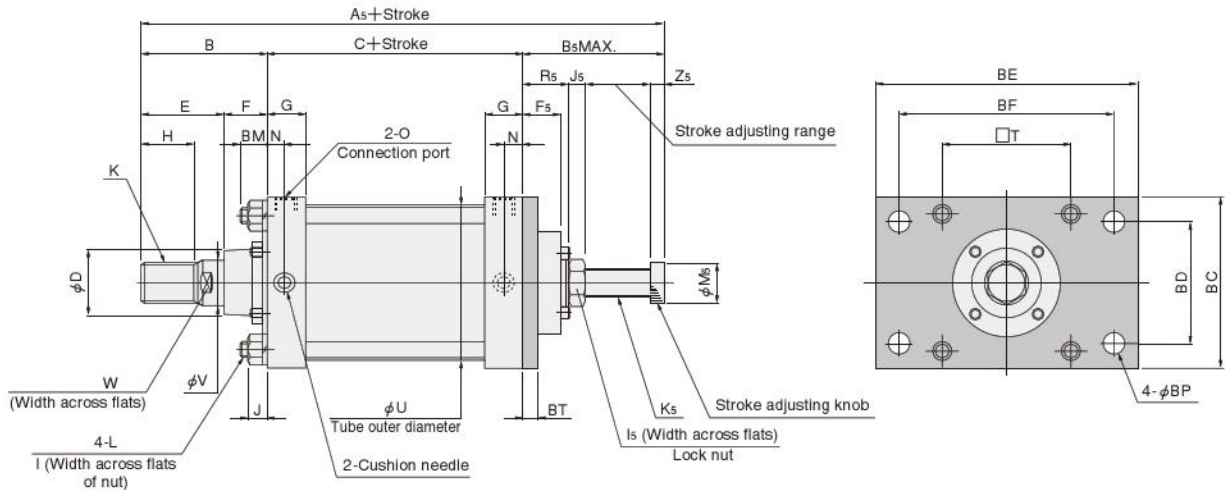

Bore mm [in.]	Code	A _s	B	B _s	C	D	E	F	F _s	G	H	I	I _s	J	J _s	K	K _s	L
125 [4.921]		336	110	128	98	60	72	38	35	35	50	22	36	14.5	14	M30×1.5	M24×1.5	M14×1.5
140 [5.512]		336	110	128	98	60	72	38	35	35	50	22	36	14.5	14	M30×1.5	M24×1.5	M14×1.5
160 [6.299]		350	120	124	106	60	82	38	35	39	56	24	36	17	14	M36×1.5	M24×1.5	M16×1.5

Bore mm [in.]	Code	M _s	N	O	R _s	T	U	V	W	Z _s	BC	BD	BE	BF	BM	BP	BT
125 [4.921]		35	16	Rc1/2	43	115	134(135)	35	32	12	145	100	230	190	23	19	14
140 [5.512]		35	16	Rc1/2	43	128	150	35	32	12	160	112	255	212	17	19	20
160 [6.299]		35	18.5	Rc3/4	43	144	170	40	36	12	182	118	275	236	20	19	20

Figures in parentheses () are for cylinders with magnets.

Dimensions of Pull Side Stroke Adjusting, Trunnion Mounting Type (mm)

KA11SDE Bore size Stroke

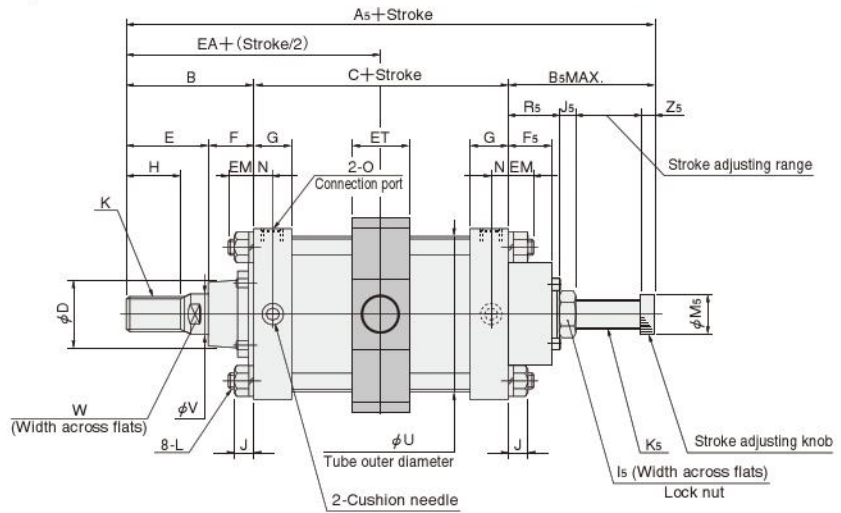
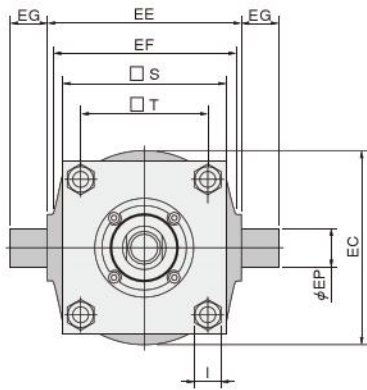

Bore size [mm]	Code	A _s	B	B _s	C	D	E	F	F _s	G	H	I	I _s	J	J _s	K	K _s	L
125	[4.921]	336	110	128	98	60	72	38	35	35	50	22	36	14.5	14	M30×1.5	M24×1.5	M14×1.5
140	[5.512]	336	110	128	98	60	72	38	35	35	50	22	36	14.5	14	M30×1.5	M24×1.5	M14×1.5
160	[6.299]	350	120	124	106	60	82	38	35	39	56	24	36	17	14	M36×1.5	M24×1.5	M16×1.5

Bore size [mm]	Code	M ₅	N	O	R _s	S	T	U	V	W	Z _s	EA	EC	EE	EF	EG	EM	EP	ET
125	[4.921]	35	16	Rc1/2	43	145	115	134(135)	35	32	12	159	164	170 ^{-0.1} _{-0.4}	160	32	18	32 ^{-0.050} _{-0.089}	50
140	[5.512]	35	16	Rc1/2	43	160	128	150	35	32	12	159	184	190 ^{-0.1} _{-0.4}	180	36	18	36 ^{-0.050} _{-0.089}	55
160	[6.299]	36	18.5	Rc3/4	43	182	144	170	40	36	12	173	208	212 ^{-0.1} _{-0.4}	200	40	19.5	40 ^{-0.050} _{-0.089}	60

Figures in parentheses () are for cylinders with magnets.

Discontinued

SD LOW HYDRAULIC CYLINDERS



Symbol



Specifications

Item	Bore size mm [in.]	125 [4.921]	140 [5.512]	160 [6.299]	180 [7.087]	200 [7.874]
Operation type		Double acting type				
Media		Turbine oil with defoaming agent (ISO VG22~100 or equivalent) or petroleum-based hydraulic oil				
Mounting type		Basic type, Foot type, Rod side flange type, Head side flange type, Clevis type, Pivot type, Trunnion type				
Operating pressure range MPa [psi.]		0.05~0.97 [7~141]				
Proof pressure MPa [psi.]		1.47 [213]				
Operating temperature range °C [°F]		0~60 [32~140]				
Operating speed range mm/s [in./sec.]		1~150 [0.04~5.91]				
Cushion		None				
Lubrication		Not required				
Port size	Rc	1/2		3/4		

Bore Size and Stroke

mm			
	Bore size	Standard strokes	Maximum available stroke
Standard cylinder	125	0~1000	1000
	140		
	160		
	180		
	200	0~990	990

Remark: Minimum available stroke of trunnion mounting type is
 ϕ 125: 22mm, ϕ 140: 27mm, ϕ 160: 32mm, ϕ 180: 29mm, and
 ϕ 200: 34mm.

The strokes listed below or larger should be included with class 2 pressure vessels. mm

Bore size	Cylinder stroke
125	3640
140	2615
160	1990
180	1573
200	1000

Order Codes

KA SDH 125×100 - - -

Bore size
×
Stroke

Piston rod specification
Blank — Standard type
RS — SUS rod (Available as a special)
● For delivery, consult us.

Rod end accessory
Blank — No rod end accessory
Y — With Y type knuckle (with pin)
I — With I type knuckle

Cylinder specification
Blank — Standard
J — With bellows

Rod end nut
Blank — No nut
N1 — With 1 nut
N2 — With 2 nuts

Mounting type
0 — Basic type
1 — Foot mounting type
3 — Rod side flange mounting type
5 — Head side flange mounting type
7 — Clevis mounting type (with pin)
8 — Pivot mounting type
11 — Trunnion mounting type

Inner Construction and Major Parts

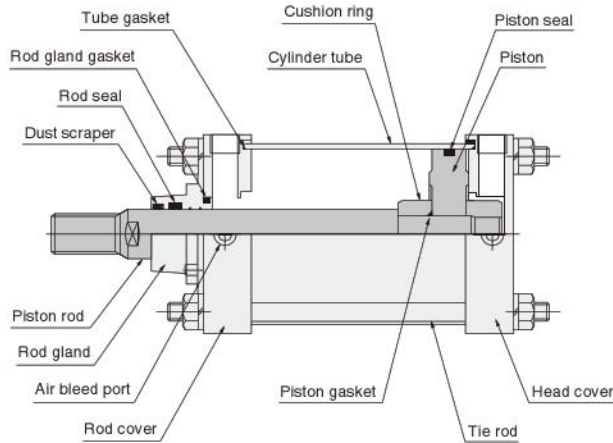

● Air bleed port

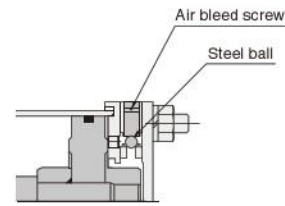

● How to bleed air

With the air bleed port facing up, loosening the air bleed screw will let the air out of the cylinder.

Major Parts and Materials

Parts	Bore size mm	125	140	160	180	200
Cylinder tube		Steel pipe (inside: hard chrome plated, outside: silver metallic painted)				
Piston		Cast iron				
Piston rod		Steel (hard chrome plated) (-RS : SUS)				
Cushion ring		Mild steel (zinc plated)				
Rod cover		Mild steel (black oxide)				
Head cover						
Tie rod		Mild steel (zinc plated)				
Rod gland		Aluminum alloy (hard anodized)				
Seal		Synthetic rubber (NBR)				

Parts	Bore size mm	125	140	160	180	200
Foot mounting bracket		Mild steel (painted)				
Flange mounting bracket		Cast iron (manganese treated)				
Clevis mounting bracket						
Pivot mounting bracket						
Trunnion mounting bracket		Cast iron (manganese treated)				
Bellows		Nylon tarpaulin				
I type knuckle		Mild steel (alkali coloring)				
Y type knuckle		Cast iron (manganese treated)				
Pin		Steel (zinc plated)				

Seals

Item	Dust scraper★	Rod seal★	Rod gland gasket	Cylinder tube gasket★	Piston seal★	Piston gasket
Bore size mm	Quantity					
125	1	1	1	2	1	1
125	SDR-35	SKY-35	G-50	S-120	P-115	G-25
140	SDR-35	SKY-35	G-50	S-135	P-130	G-25
160	SDR-40	SKY-40	G-50	#160	P-150	G-25
180	SDR-45	SKY-45	G-60	#180	P-165	G-35
200	SDR-50	SKY-50	G-60	#200	P-185	G-35

Remark: Items marked with a star (★) are available as repair kits. The order code is the **SRK-NSDH** [Bore size].

Note that the contents of a repair kit is 1 dust scraper, 1 rod seal, 1 piston seal, and 2 cylinder tube gaskets.

Note, however, that the repair kits with bore size of 125mm and 140mm cannot be used with SD cylinders manufactured prior to April 6, 2000 (because the piston rod diameters have been changed). For details, see p.543.

Mass

Bore size mm [in.]	Zero stroke mass						Additional mass for each 1mm [0.0394in.] stroke	Additional mass		
	Basic type	Foot mounting type	Flange mounting type	Clevis mounting type (With pin)	Pivot mounting type	Trunnion mounting type		Nut	Y type knuckle (With pin)	I type knuckle
125 [4.921]	14.8 [32.6]	16.5 [36.4]	17.3 [38.1]	18.7 [41.2]	18.3 [40.4]	18.2 [40.1]	0.0256 [0.0564]	0.2 [0.4]	1.5 [3.3]	1.5 [3.3]
140 [5.512]	17.8 [39.2]	20.4 [45.0]	22.4 [49.4]	23.0 [50.7]	22.6 [49.8]	22.3 [49.2]	0.0291 [0.0642]	0.2 [0.4]	1.6 [3.5]	1.9 [4.2]
160 [6.299]	24.9 [54.9]	27.8 [61.3]	30.7 [67.7]	31.9 [70.3]	31.1 [68.6]	31.7 [69.9]	0.0352 [0.0776]	0.3 [0.7]	2.1 [4.6]	2.8 [6.2]
180 [7.087]	32.6 [71.9]	37.0 [81.6]	41.8 [92.2]	44.2 [97.5]	42.6 [93.9]	40.9 [90.2]	0.0495 [0.1091]	0.4 [0.9]	3.9 [8.6]	3.9 [8.6]
200 [7.874]	40.9 [90.2]	45.7 [100.8]	51.7 [114.0]	53.1 [117.1]	52.9 [116.6]	52.5 [115.8]	0.0573 [0.1263]	0.6 [1.3]	3.7 [8.2]	4.0 [8.8]

Calculation example: For foot mounting type, bore size 140mm, and stroke of 100mm, $20.4 + (0.0291 \times 100) = 23.31\text{kg}$ [51.39lb.]

Dimensions of Basic Type (mm)

KA0SDH Bore size X Stroke

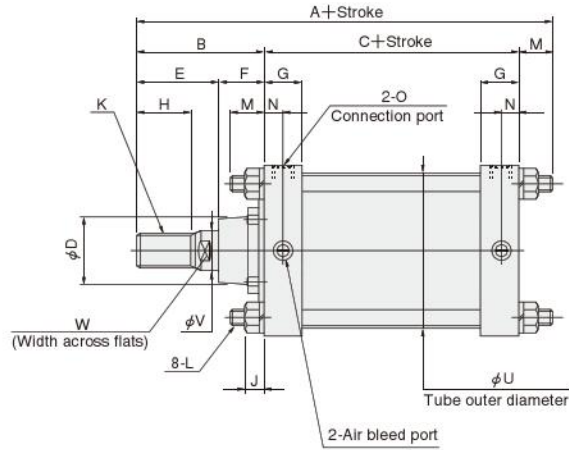
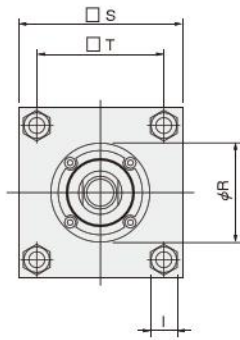

Bore mm [in.]	Code	A	B	C	D	E	F	G	H	I	J	K
125 [4.921]		235	110	98	60	72	38	35	50	22	14.5	M30×1.5
140 [5.512]		235	110	98	60	72	38	35	50	22	14.5	M30×1.5
160 [6.299]		256.5	120	106	60	82	38	39	56	24	17	M36×1.5
180 [7.087]		281	135	111	70	95	40	39	63	27	19.6	M40×1.5
200 [7.874]		281	135	111	70	95	40	39	63	30	21.1	M45×1.5

Bore mm [in.]	Code	L	M	N	O	R	S	T	U	V	W
125 [4.921]		M14×1.5	27	16	Rc1/2	90 ^{-0.1} _{-0.2}	145	115	134	35	32
140 [5.512]		M14×1.5	27	16	Rc1/2	90 ^{-0.1} _{-0.2}	160	128	150	35	32
160 [6.299]		M16×1.5	30.5	18.5	Rc3/4	90 ^{-0.1} _{-0.2}	182	144	170	40	36
180 [7.087]		M18×1.5	35	18.5	Rc3/4	115 ^{-0.1} _{-0.2}	204	162	193	45	41
200 [7.874]		M20×1.5	35	18.5	Rc3/4	115 ^{-0.1} _{-0.2}	226	182	213	50	46

Dimensions of Foot Mounting Type (mm)

KA1SDH Bore size X Stroke

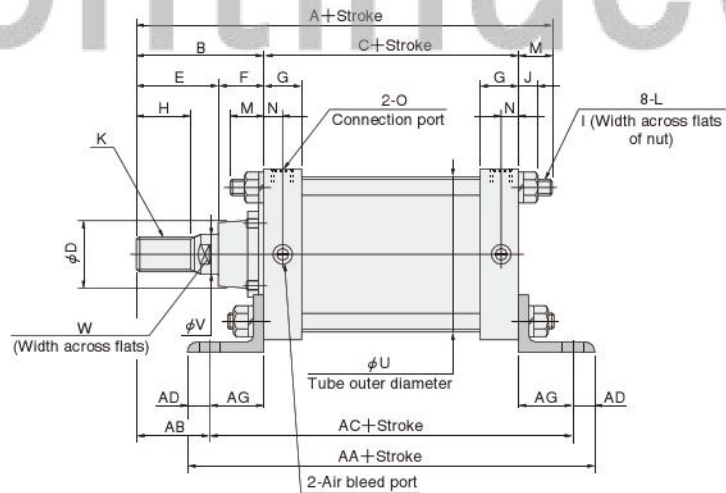
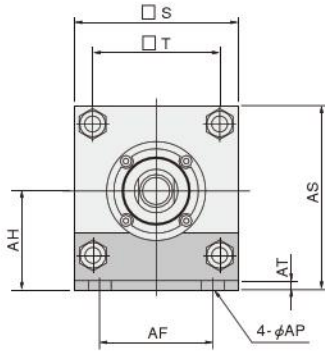

Bore mm [in.]	Code	A	B	C	D	E	F	G	H	I	J	K	L	M	N	O
125 [4.921]		235	110	98	60	72	38	35	50	22	14.5	M30×1.5	M14×1.5	27	16	Rc1/2
140 [5.512]		235	110	98	60	72	38	35	50	22	14.5	M30×1.5	M14×1.5	27	16	Rc1/2
160 [6.299]		256.5	120	106	60	82	38	39	56	24	17	M36×1.5	M16×1.5	30.5	18.5	Rc3/4
180 [7.087]		281	135	111	70	95	40	39	63	27	19.6	M40×1.5	M18×1.5	35	18.5	Rc3/4
200 [7.874]		281	135	111	70	95	40	39	63	30	21.1	M45×1.5	M20×1.5	35	18.5	Rc3/4

Bore mm [in.]	Code	S	T	U	V	W	AA	AB	AC	AD	AF	AG	AH	AP	AS	AT
125 [4.921]		145	115	134	35	32	228	65	188	20	100	45	85	19	157.5	8
140 [5.512]		160	128	150	35	32	248	65	188	30	112	45	100	19	180	9
160 [6.299]		182	144	170	40	36	256	70	206	25	118	50	106	19	197	9
180 [7.087]		204	162	193	45	41	291	75	231	30	132	60	125	24	227	10
200 [7.874]		226	182	213	50	46	291	75	231	30	150	60	132	24	245	10

Dimensions of Rod Side Flange Mounting Type (mm)

KA3SDH Bore size X Stroke

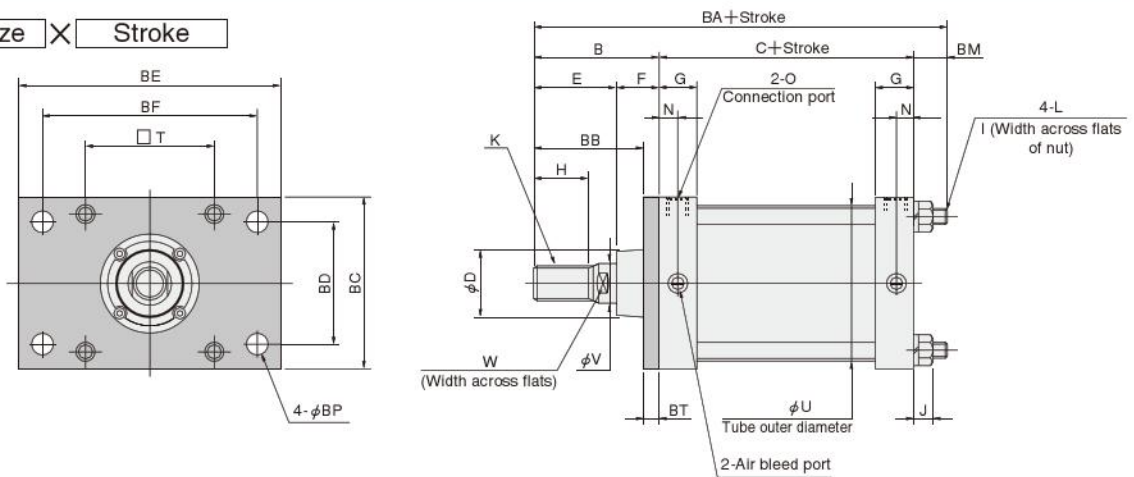

Bore mm [in.]	Code	B	C	D	E	F	G	H	I	J	K	L	N
125	[4.921]	110	98	60	72	38	35	50	22	14.5	M30×1.5	M14×1.5	16
140	[5.512]	110	98	60	72	38	35	50	22	14.5	M30×1.5	M14×1.5	16
160	[6.299]	120	106	60	82	38	39	56	24	17	M36×1.5	M16×1.5	18.5
180	[7.087]	135	111	70	95	40	39	63	27	19.6	M40×1.5	M18×1.5	18.5
200	[7.874]	135	111	70	95	40	39	63	30	21.1	M45×1.5	M20×1.5	18.5

Bore mm [in.]	Code	O	T	U	V	W	BA	BB	BC	BD	BE	BF	BM	BP	BT
125	[4.921]	Rc1/2	115	134	35	32	231	96	145	100	230	190	23	19	14
140	[5.512]	Rc1/2	128	150	35	32	225	90	160	112	255	212	17	19	20
160	[6.299]	Rc3/4	144	170	40	36	246	100	182	118	275	236	20	19	20
180	[7.087]	Rc3/4	162	193	45	41	269	110	204	132	320	265	23	24	25
200	[7.874]	Rc3/4	182	213	50	46	271	110	226	150	335	280	25	24	25

Dimensions of Head Side Flange Mounting Type (mm)

KA5SDH Bore size X Stroke

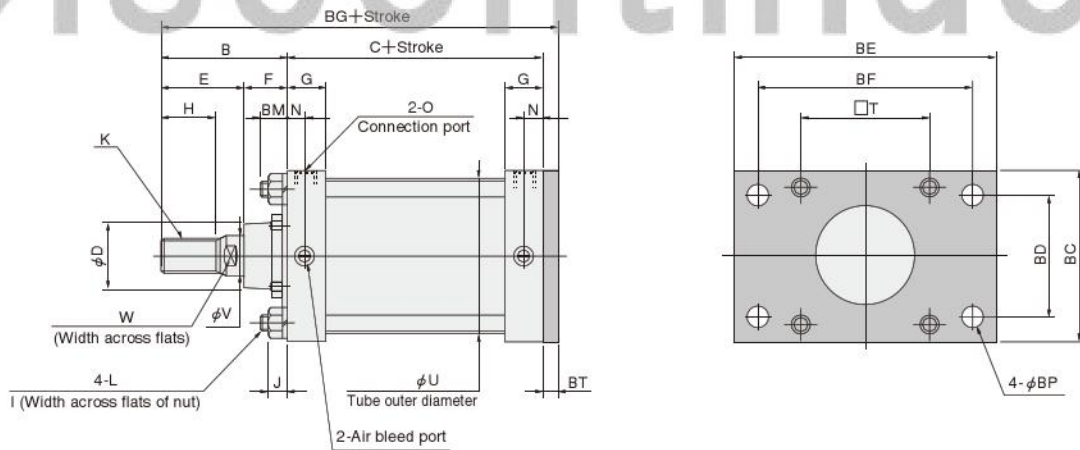

Bore mm [in.]	Code	B	C	D	E	F	G	H	I	J	K	L	N
125	[4.921]	110	98	60	72	38	35	50	22	14.5	M30×1.5	M14×1.5	16
140	[5.512]	110	98	60	72	38	35	50	22	14.5	M30×1.5	M14×1.5	16
160	[6.299]	120	106	60	82	38	39	56	24	17	M36×1.5	M16×1.5	18.5
180	[7.087]	135	111	70	95	40	39	63	27	19.6	M40×1.5	M18×1.5	18.5
200	[7.874]	135	111	70	95	40	39	63	30	21.1	M45×1.5	M20×1.5	18.5

Bore mm [in.]	Code	O	T	U	V	W	BC	BD	BE	BF	BG	BM	BP	BT
125	[4.921]	Rc1/2	115	134	35	32	145	100	230	190	222	23	19	14
140	[5.512]	Rc1/2	128	150	35	32	160	112	255	212	228	17	19	20
160	[6.299]	Rc3/4	144	170	40	36	182	118	275	236	246	20	19	20
180	[7.087]	Rc3/4	162	193	45	41	204	132	320	265	271	23	24	25
200	[7.874]	Rc3/4	182	213	50	46	226	150	335	280	271	25	24	25

Dimensions of Clevis Mounting Type (mm)

KA7SDH Bore size × Stroke

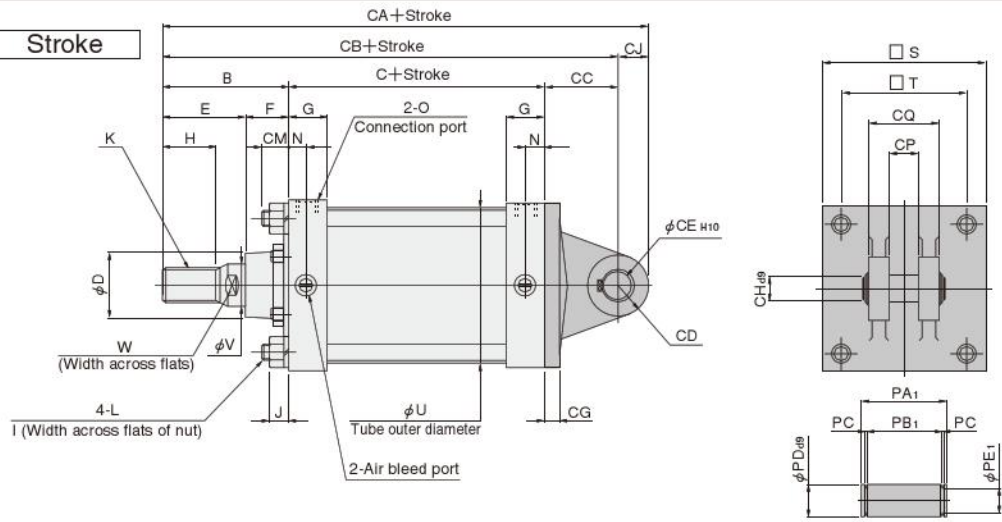

Bore mm [in.]	Code	B	C	D	E	F	G	H	I	J	K	L	N	O	S	T	U
125 [4.921]		110	98	60	72	38	35	50	22	14.5	M30×1.5	M14×1.5	16	Rc1/2	145	115	134
140 [5.512]		110	98	60	72	38	35	50	22	14.5	M30×1.5	M14×1.5	16	Rc1/2	160	128	150
160 [6.299]		120	106	60	82	38	39	56	24	17	M36×1.5	M16×1.5	18.5	Rc3/4	182	144	170
180 [7.087]		135	111	70	95	40	39	63	27	19.6	M40×1.5	M18×1.5	18.5	Rc3/4	204	162	193
200 [7.874]		135	111	70	95	40	39	63	30	21.1	M45×1.5	M20×1.5	18.5	Rc3/4	226	182	213

Bore mm [in.]	Code	V	W	CA	CB	CC	CD	CE	CG	CH	CJ	CM	CP	CQ	PA ₁	PB ₁	PC	PD	PE ₁
125 [4.921]		35	32	301	273	65	R28	25 ^{+0.084} ₀	18	25 ^{-0.065} _{-0.117}	28	19	32 ^{+0.4} _{+0.1}	64 ^{-0.1} _{-0.4}	73	65 ±0.5	1.35 ^{+0.14} ₀	25 ^{-0.065} _{-0.117}	23.9 ⁰ _{-0.21}
140 [5.512]		35	32	315	283	75	R32	28 ^{+0.084} ₀	20	28 ^{-0.065} _{-0.117}	32	17	36 ^{+0.4} _{+0.1}	72 ^{-0.1} _{-0.4}	82	73 ±0.5	1.65 ^{+0.14} ₀	28 ^{-0.065} _{-0.117}	26.6 ⁰ _{-0.21}
160 [6.299]		40	36	342	306	80	R36	32 ^{+0.100} ₀	20	32 ^{-0.080} _{-0.142}	36	20	40 ^{+0.4} _{+0.1}	80 ^{-0.1} _{-0.4}	90	81 ±0.5	1.65 ^{+0.14} ₀	32 ^{-0.080} _{-0.142}	30.3 ⁰ _{-0.25}
180 [7.087]		45	41	379	336	90	R43	40 ^{+0.100} ₀	25	40 ^{-0.080} _{-0.142}	43	23	50 ^{+0.4} _{+0.1}	100 ^{-0.1} _{-0.4}	113	101.5 ±0.5	1.9 ^{+0.14} ₀	40 ^{-0.080} _{-0.142}	38 ⁰ _{-0.25}
200 [7.874]		50	46	381	336	90	R45	40 ^{+0.100} ₀	25	40 ^{-0.080} _{-0.142}	45	25	50 ^{+0.4} _{+0.1}	100 ^{-0.1} _{-0.4}	113	101.5 ±0.5	1.9 ^{+0.14} ₀	40 ^{-0.080} _{-0.142}	38 ⁰ _{-0.25}

Dimensions of Pivot Mounting Type (mm)

KA8SDH Bore size × Stroke

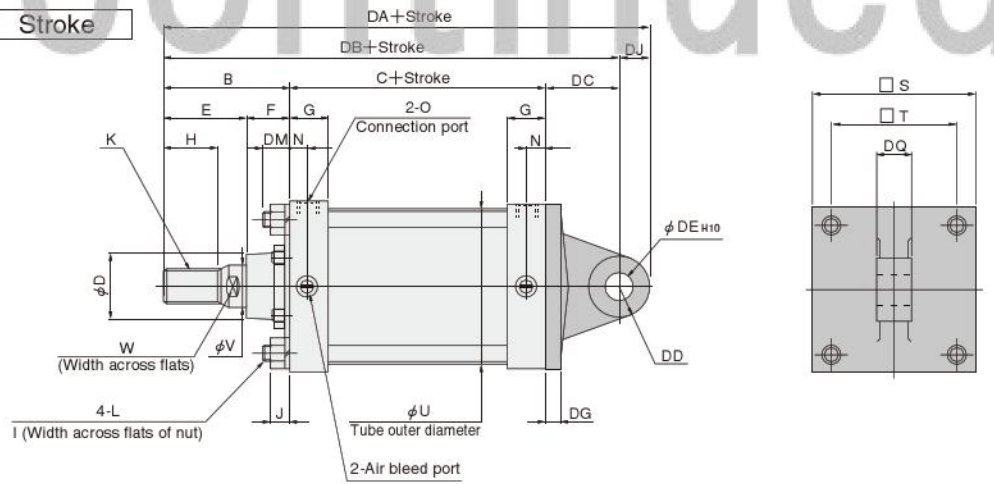

Bore mm [in.]	Code	B	C	D	E	F	G	H	I	J	K	L	N	O
125 [4.921]		110	98	60	72	38	35	50	22	14.5	M30×1.5	M14×1.5	16	Rc1/2
140 [5.512]		110	98	60	72	38	35	50	22	14.5	M30×1.5	M14×1.5	16	Rc1/2
160 [6.299]		120	106	60	82	38	39	56	24	17	M36×1.5	M16×1.5	18.5	Rc3/4
180 [7.087]		135	111	70	95	40	39	63	27	19.6	M40×1.5	M18×1.5	18.5	Rc3/4
200 [7.874]		135	111	70	95	40	39	63	30	21.1	M45×1.5	M20×1.5	18.5	Rc3/4

Bore mm [in.]	Code	S	T	U	V	W	DA	DB	DC	DD	DE	DG	DJ	DM	DQ
125 [4.921]		145	115	134	35	32	301	273	65	R28	25 ^{+0.084} ₀	18	28	19	32 ^{-0.1} _{-0.4}
140 [5.512]		160	128	150	35	32	315	283	75	R32	28 ^{+0.084} ₀	20	32	17	36 ^{-0.1} _{-0.4}
160 [6.299]		182	144	170	40	36	342	306	80	R36	32 ^{+0.100} ₀	20	36	20	40 ^{-0.1} _{-0.4}
180 [7.087]		204	162	193	45	41	379	336	90	R43	40 ^{+0.100} ₀	25	43	23	50 ^{-0.1} _{-0.4}
200 [7.874]		226	182	213	50	46	381	336	90	R45	40 ^{+0.100} ₀	25	45	25	50 ^{-0.1} _{-0.4}

Dimensions of Trunnion Mounting Type (mm)

KA11SDH Bore size X Stroke

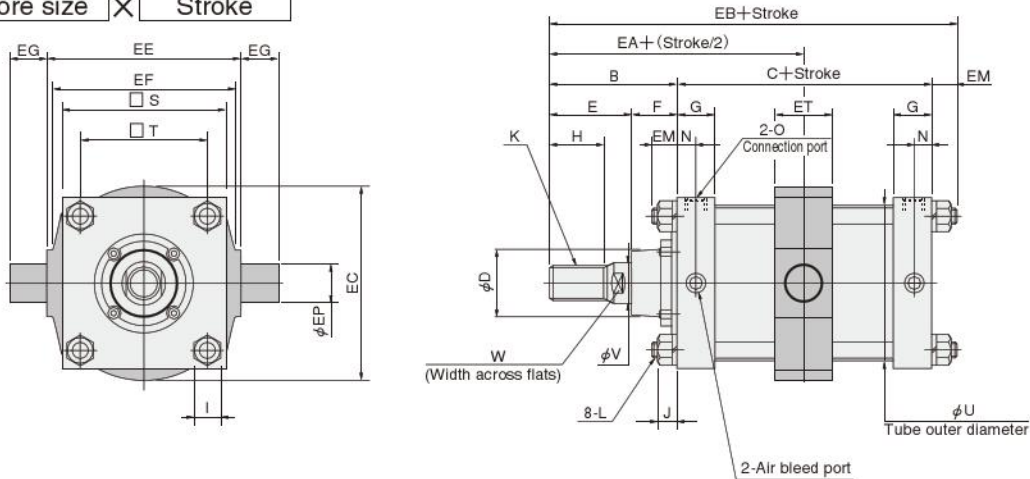

Bore mm [in.]	Code	B	C	D	E	F	G	H	I	J	K	L	N	O
	125 [4.921]	110	98	60	72	38	35	50	22	14.5	M30×1.5	M14×1.5	16	Rc1/2
	140 [5.512]	110	98	60	72	38	35	50	22	14.5	M30×1.5	M14×1.5	16	Rc1/2
	160 [6.299]	120	106	60	82	38	39	56	24	17	M36×1.5	M16×1.5	18.5	Rc3/4
	180 [7.087]	135	111	70	95	40	39	63	27	19.6	M40×1.5	M18×1.5	18.5	Rc3/4
	200 [7.874]	135	111	70	95	40	39	63	30	21.1	M45×1.5	M20×1.5	18.5	Rc3/4

Bore mm [in.]	Code	S	T	U	V	W	EA	EB	EC	EE	EF	EG	EM	EP	ET
	125 [4.921]	145	115	134	35	32	159	226	164	170 ^{-0.1} _{-0.4}	160	32	18	32 ^{-0.050} _{-0.089}	50
	140 [5.512]	160	128	150	35	32	159	226	184	190 ^{-0.1} _{-0.4}	180	36	18	36 ^{-0.050} _{-0.089}	55
	160 [6.299]	182	144	170	40	36	173	245.5	208	212 ^{-0.1} _{-0.4}	200	40	19.5	40 ^{-0.050} _{-0.089}	60
	180 [7.087]	204	162	193	45	41	190.5	269.5	225	236 ^{-0.1} _{-0.6}	225	45	23.5	45 ^{-0.050} _{-0.089}	62
	200 [7.874]	226	182	213	50	46	190.5	270.5	255	265 ^{-0.1} _{-0.6}	255	45	24.5	45 ^{-0.050} _{-0.089}	67

Discontinued

SENSOR SWITCHES

Solid State Type, Reed Switch Type

Symbol

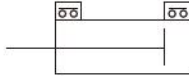

Order Codes

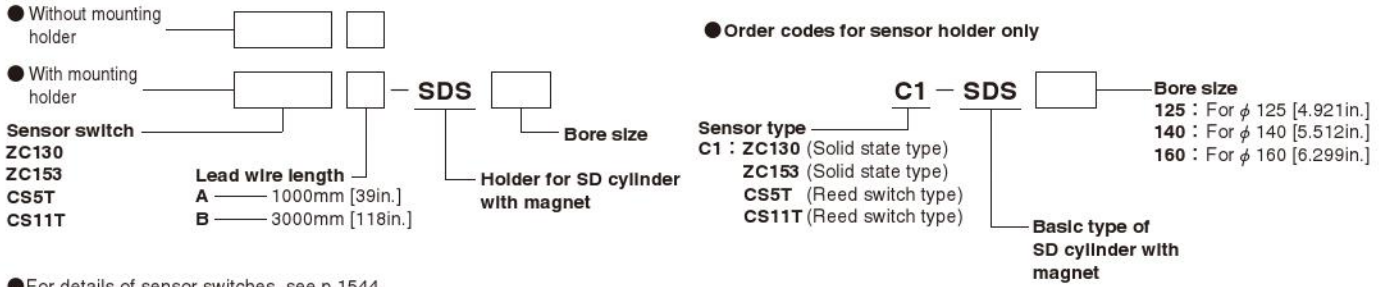

Minimum Cylinder Strokes When Using Sensor Switches

Sensor switch model		Bore size mm [in.]	2 pcs. mounting				1 pc. mounting	
			Mounting 2 pcs. on a tie rod		Mounting 1 pc. on each tie rod		Rod side	Head side
			In a straight line	In staggered positions	1-plane mounting	2-plane mounting		
Solid state type	ZC130	125 [4.921]	52(112)	42(112)	17(112)		17(112)	
	ZC153	140 [5.512]	52(117)	42(117)	17(117)		17(117)	
		160 [6.299]	52(122)	42(122)	17(122)		17(122)	
Reed switch type	CS5T	125 [4.921]	55(115)	45(115)	19(115)	19(115)		
		140 [5.512]	55(120)	45(120)	19(120)	19(120)		
		160 [6.299]	55(125)	45(125)	19(125)	19(125)		
	CS11T	125 [4.921]	48(108)	38(108)	15(108)		15(108)	
		140 [5.512]	48(113)	38(113)	15(113)		15(113)	
		160 [6.299]	48(118)	38(118)	15(118)		15(118)	

Note: Figures in parentheses () are for trunnion mounting type.

- When mounting 2 sensors on a tie rod ● When mounting 1 sensor on each tie rod ● Trunnion mounting type



Sensor Switch Operating Range, Response Differential, and Maximum Sensing Location

● **Operating range: ℓ**

The distance the piston travels in one direction, while the switch is in the ON position.

● **Response differential: C**

The distance between the point where the piston turns the switch ON and the point where the switch is turned OFF as the piston travels in the opposite direction.

Sensor switch model	Solid state type		Reed switch type	
	ZC130, ZC153	CS5T	CS11T	
Operation range: ℓ	5 ± 1.5 [0.197 ± 0.059]	12.5 ± 3 [0.492 ± 0.118]		
Response differential: C	1 [0.039] MAX.	3 [0.118] MAX.		
Maximum sensing location ^{Note}	8.5 [0.335]	7 [0.276]	10.5 [0.413]	

Note: This is the length measured from the opposite end side of the indicator to the lead wire.

Remark: the above table shows reference values at normal temperature (25°C [77°F]).

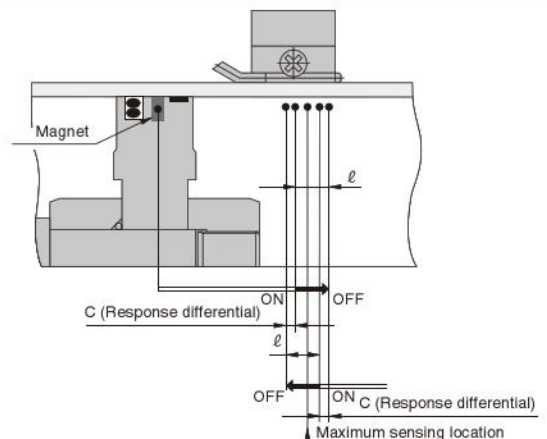

Mounting Location of Sensor Switch

When the sensor switch is mounted in the location shown in the diagram (figures in the tables are reference values), the magnet comes to the sensor switch's maximum sensing location at the end of the stroke.

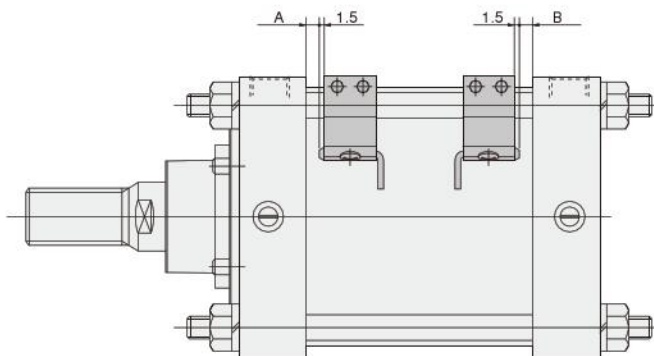

		mm [in.]			
Sensor switch model	Location	Bore size			
		φ 125	φ 140	φ 160	
Solid state type	ZC130	A	8 [0.315]	9 [0.354]	10.5 [0.413]
	ZC131	B	3 [0.118]	2 [0.079]	0.5 [0.020]
Reed switch type	CS5T	A	9.5 [0.374]	10.5 [0.413]	12 [0.472]
		B	4.5 [0.177]	3.5 [0.138]	2 [0.079]
	CS11T	A	6 [0.236]	7 [0.276]	8.5 [0.335]
		B	1 [0.039]	0 [0]	0 [0]

- Notes: 1. When a sensor switch is mounted with the lead wire facing on the outer side (opposite direction shown in the diagram), the maximum sensing location does not come at the end of the stroke.
2. For the trunnion mounting type, set the maximum sensing location at least 15mm [0.591in.] away from the trunnion bracket end surface.

Dimensions of Sensor Switch (mm)

Caution at mounting

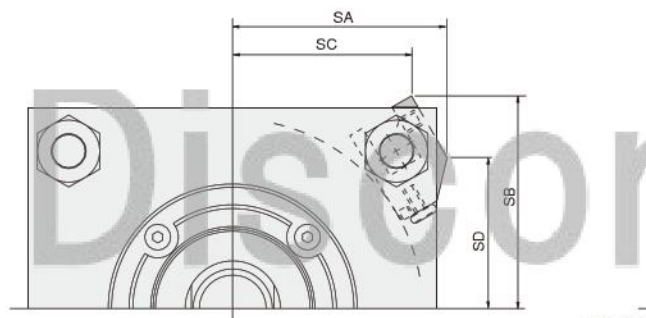
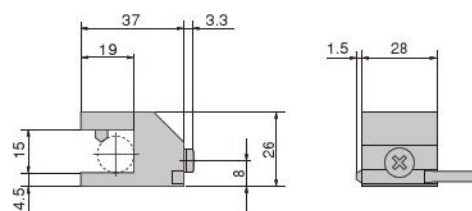
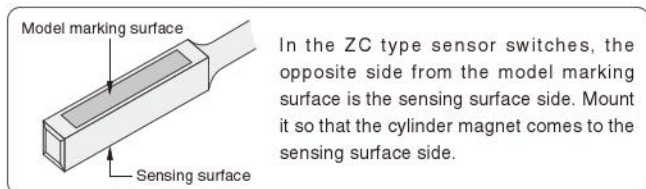

Bore size	Code	SA	SB	SC	SD
φ 125 [4.921]		76.7 [3.020]	75.8 [2.984]	64.4 [2.535]	54.1 [2.130]
φ 140 [5.512]		83 [3.268]	81.9 [3.224]	72 [2.835]	59.4 [2.339]
φ 160 [6.299]		90.6 [3.567]	88.7 [3.492]	79.3 [3.122]	66.4 [2.614]

Mounting and Moving Sensor Switch

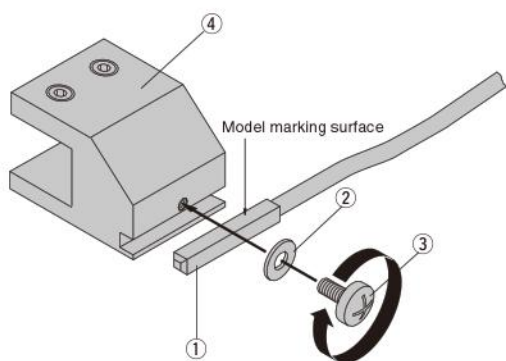

- As shown in the diagram, mount the sensor switch ① to the holder ④ with the washer ② and the screw ③, as the model marking surface facing upward. (Tightening torque: 70N·cm [6.2in·lbf])
At this time, mount so that only the sensor switch indicator lamp protrudes from the holder.
To protect the switch, however, make sure the switch body does not protrude from the holder.

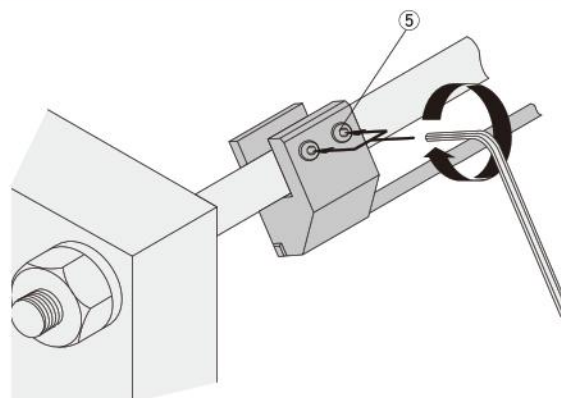

- Fit the holder onto the position for the SD cylinder tie rod, and use an Allen wrench (width across flats B=3) to secure the holder with the screw ⑤ in place. (Tightening torque: 200N·cm [17.7in·lbf])
At this time, mount the bottom of the holder comes in contact with the cylinder tube.
The holder can be mounted on either side of the sensor switch. Moreover, no matter which tie rod is used, the holder and sensor switch can be freely mounted in any direction.

ROD END ACCESSORIES, BELLOWS



Dimensions of Y Type Knuckle (mm)

● ϕ 125 [4.921in.]~200 [7.874in.]
(Standard type)

ϕ 125~ ϕ 160 :SD-Y1
 ϕ 180~ ϕ 200 :SD-Y2

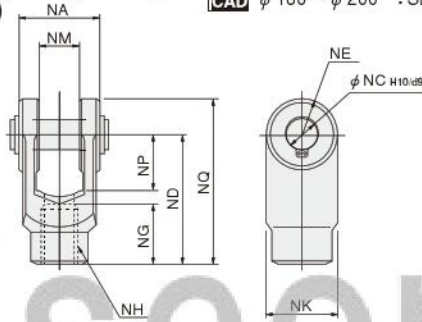

● ϕ 200
[7.874in.]
(Heavy duty rod type)

SD-Y2

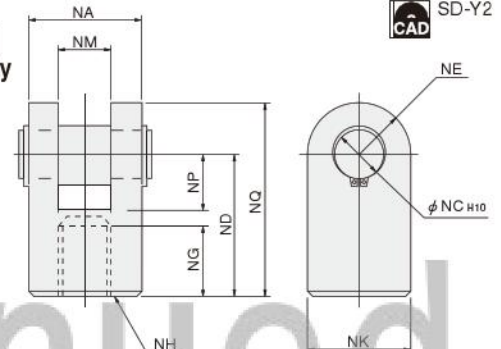

Order code <small>Note</small>	Applicable type		NA	NC	ND	NE	NG	NH	NK	NM	NP	NQ	Mass kg [lb.]
	Standard type	Heavy duty rod type											
Y-SD125	SD125	—	64 ^{+0.1} _{-0.4}	25	100	R27	45	M30×1.5	54	32 ^{+0.4} _{+0.1}	42	127	1.5 [3.3]
Y-SD140	SD140	—	72 ^{+0.1} _{-0.4}	28	105	R27	45	M30×1.5	54	36 ^{+0.4} _{+0.1}	45	132	1.6 [3.5]
Y-SD160	SD160	SDZ125, SDZ140	80 ^{+0.1} _{-0.4}	32	110	R30	48	M36×1.5	60	40 ^{+0.4} _{+0.1}	47	140	2.1 [4.6]
Y-SD180	SD180	SDZ160	100 ^{+0.1} _{-0.4}	40	125	R35	55	M40×1.5	70	50 ^{+0.4} _{+0.1}	54	160	3.9 [8.6]
Y-SD200	SD200	SDZ180	100 ^{+0.1} _{-0.4}	40	125	R35	55	M45×1.5	70	50 ^{+0.4} _{+0.1}	54	160	3.7 [8.2]
Y-SDZ200	—	SDZ200	100 ^{+0.1} _{-0.4}	40	125	R45	73	M56×2	90	50 ^{+0.4} _{+0.1}	50	170	7.8 [17.2]

Note: Pin is included with Y type knuckles.

Dimensions of I Type Knuckle (mm)

ϕ 125~ ϕ 160 :SD-I1
 ϕ 180~ ϕ 200 :SD-I2
 ϕ 200
(Heavy duty rod) :SD-I2

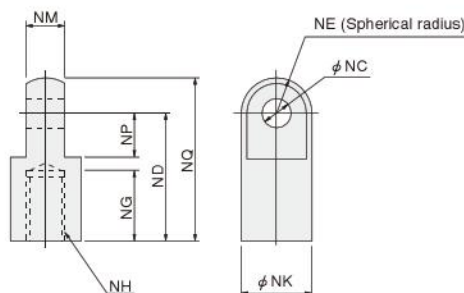

Order code	Applicable type		NC	ND	NE	NG	NH	NK	NM	NP	NQ	Mass kg [lb.]
	Standard type	Heavy duty rod type										
I-SD125	SD125	—	25	100	R27.5	55	M30×1.5	55	32 ^{+0.1} _{-0.4}	35	127.5	1.5 [3.3]
I-SD140	SD140	—	28	105	R30	55	M30×1.5	60	36 ^{+0.1} _{-0.4}	40	135	1.9 [4.2]
I-SD160	SD160	SDZ125, SDZ140	32	110	R35	58	M36×1.5	70	40 ^{+0.1} _{-0.4}	45	145	2.8 [6.2]
I-SD180	SD180	SDZ160	40	125	R40	65	M40×1.5	80	50 ^{+0.1} _{-0.4}	50	165	3.9 [8.6]
I-SD200	SD200	SDZ180	40	125	R40	65	M45×1.5	80	50 ^{+0.1} _{-0.4}	50	165	4.0 [8.8]
I-SDZ200	—	SDZ200	40	125	R40	46	M56×2	80	50 ^{+0.1} _{-0.4}	50	165	4.0 [8.8]

Dimensions of Pin for Knuckles and Clevis (mm)

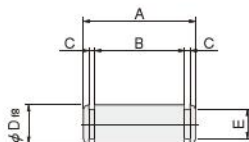

Caution The clevis pin for the heavy duty rod type is the same as the standard type. When placing orders, use the order code that corresponds to the standard type for the targeted model.
 (Example) Clevis pin for heavy duty rod type
 φ 125
 Code **P-SD125**

Order code	Applicable type		A	B	C	D	E	Mass kg [lb.]	Snap ring nominal size	
	Standard type	Heavy duty rod type							Standard type	Heavy duty rod type
P-SD125	SD125	—	75	66.3 ±0.5	1.35 ^{+0.14} ₀	25 ^{-0.020} _{-0.053}	23.9 ⁰ _{-0.21}	0.3 [0.7]	25 (External)	—
P-SD140	SD140	—	84	74.7 ±0.5	1.65 ^{+0.14} ₀	28 ^{-0.020} _{-0.053}	26.6 ⁰ _{-0.21}	0.4 [0.9]	28 (External)	—
P-SD160	SD160	SDZ125, SDZ140	92	82.7 ±0.5	1.65 ^{+0.14} ₀	32 ^{-0.025} _{-0.064}	30.3 ⁰ _{-0.25}	0.6 [1.3]	32 (External)	32 (External)
P-SD180	SD180, SD200	SDZ160, SDZ180, SDZ200	115	103.2 ±0.5	1.9 ^{+0.14} ₀	40 ^{-0.025} _{-0.064}	38 ⁰ _{-0.25}	1.1 [2.4]	40 (External)	40 (External)

Dimensions of Rod End Nut (mm)

SD-NUT

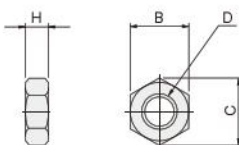

Order code	Applicable type		B	C	D	H	Mass kg [lb.]
	Standard type	Heavy duty rod type					
N-SD125	SD125, SD140	—	46	53.1	M30×1.5	18	0.2 [0.4]
N-SD160	SD160	SDZ125, SDZ140	55	63.5	M36×1.5	21	0.3 [0.7]
N-SD180	SD180	SDZ160	60	69.3	M40×1.5	23	0.4 [0.9]
N-SD200	SD200	SDZ180	70	80.8	M45×1.5	27	0.6 [1.3]
N-SDZ200	—	SDZ200	85	98.1	M56×2	34	1.0 [2.2]

Dimensions of Bellows (mm)

φ 125, φ 140 :SD-J1
 φ 160, φ 180 :SD-J2
 φ 200 :SD-J3

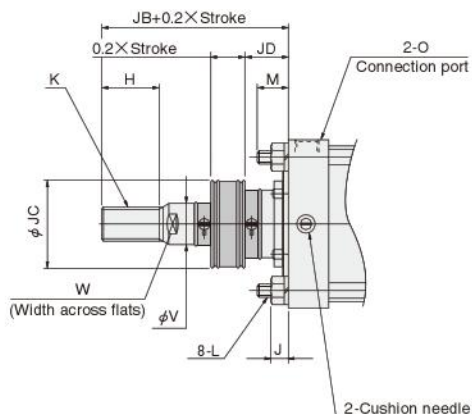

Code	D	H	K	L	M	V	W	J	JB	JC	JD
125 [4.921]	60	50	M30×1.5	M14×1.5	27	35	32	14.5	133	75	38
140 [5.512]	60	50	M30×1.5	M14×1.5	27	35	32	14.5	133	75	38
160 [6.299]	60	56	M36×1.5	M16×1.5	30.5	40	36	17	141	75	38
180 [7.087]	70	63	M40×1.5	M18×1.5	35	45	41	19.6	153	85	40
200 [7.874]	70	63	M45×1.5	M20×1.5	35	50	46	21.1	153	85	40

Discontinued