

## Swing CYLINDERS

***From a creative idea comes simple, integrated, linear and swing motions.***

The swing cylinders can provide linear and swing motions alternatively or simultaneously.

While such multiple action has until now required separate units, the swing cylinders integrate these motions for ease of use.

Cylinder bore sizes are  $\phi 25$  [0.984in.] and  $\phi 40$  [1.575in.], while the swing angles are 45°, 90°, 135°, and 180°.

### ***Features***

- 1. Greatly reduces design hours compared with that required for use of separate units for linear and swing operations.**
- 2. A fine adjusting mechanism for swing angles allows any angle settings.**
- 3. A spherical bearing is built into the piston, to obtain light and smooth swing motion.**
- 4. Sensor switches can be mounted on both the cylinder and swing portions, for exceptionally easy control.**

# Configuration

## Basic type



## Flange mounting type



## Square rod end type



Bore size  $\phi 25, \phi 40$   
Swing angle  $45^\circ, 90^\circ, 135^\circ, 180^\circ$

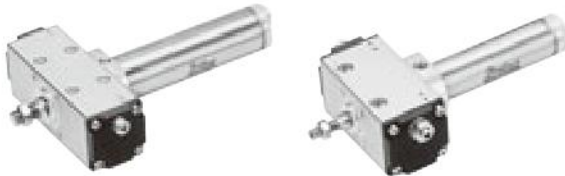

## Cylinder with magnet



## Effective Torque of Swing Portion

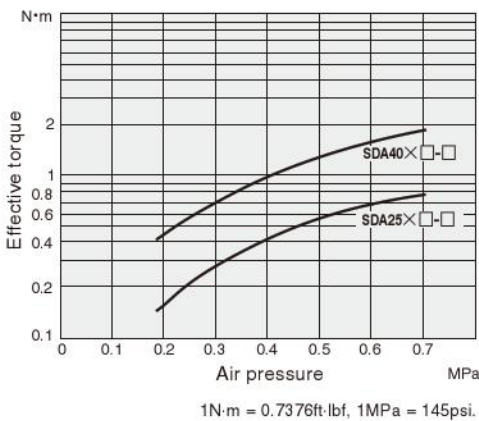

Model	Air pressure MPa [psi.]					
	0.2 [29]	0.3 [44]	0.4 [58]	0.5 [73]	0.6 [87]	0.7 [102]
SDA25×□-□	0.167 [0.123]	0.294 [0.217]	0.422 [0.311]	0.549 [0.405]	0.667 [0.492]	0.794 [0.586]
SDA40×□-□	0.461 [0.340]	0.735 [0.542]	1.01 [0.745]	1.294 [0.954]	1.559 [1.150]	1.834 [1.353]

## Air Consumption

### ● Cylinder portion

Model	Air pressure MPa [psi.]					
	0.2 [29]	0.3 [44]	0.4 [58]	0.5 [73]	0.6 [87]	0.7 [102]
SDA25×15-□	44 [2.69]	58 [3.54]	72 [4.39]	87 [5.31]	101 [6.16]	116 [7.08]
SDA25×25-□	73 [4.45]	96 [5.86]	120 [7.32]	144 [8.79]	168 [10.25]	192 [11.72]
SDA25×50-□	145 [8.85]	192 [11.72]	240 [14.65]	288 [17.57]	336 [20.50]	384 [23.43]
SDA40×15-□	111 [6.77]	148 [9.03]	184 [11.23]	221 [13.49]	258 [15.74]	294 [17.94]
SDA40×25-□	185 [11.29]	246 [15.01]	307 [18.73]	368 [22.46]	429 [26.18]	490 [29.90]
SDA40×50-□	370 [22.58]	492 [30.02]	613 [37.41]	735 [44.85]	858 [52.36]	980 [59.80]
SDA40×75-□	555 [33.87]	738 [45.04]	920 [56.14]	1110 [67.74]	1290 [78.72]	1470 [89.71]
SDA40×100-□	740 [45.16]	983 [59.99]	1230 [75.06]	1470 [89.71]	1720 [105.0]	1960 [119.6]

### ● Swing portion

Model	Air pressure MPa [psi.]					
	0.2 [29]	0.3 [44]	0.4 [58]	0.5 [73]	0.6 [87]	0.7 [102]
SDA25×□-45	7.5 [0.458]	9.9 [0.604]	12.4 [0.757]	14.9 [0.909]	17.3 [1.056]	19.8 [1.208]
SDA25×□-90	14.9 [0.909]	19.9 [1.214]	24.8 [1.513]	29.7 [1.812]	34.6 [2.111]	39.5 [2.410]
SDA25×□-135	22.4 [1.367]	29.8 [1.819]	37.1 [2.264]	44.5 [2.716]	51.6 [3.149]	59.3 [3.619]
SDA25×□-180	29.8 [1.819]	39.7 [2.423]	49.5 [3.021]	59.3 [3.619]	69.2 [4.223]	79 [4.821]
SDA40×□-45	17.4 [1.062]	23.1 [1.410]	28.9 [1.764]	34.6 [2.111]	40.3 [2.459]	45.1 [2.752]
SDA40×□-90	34.8 [2.124]	46.2 [2.819]	57.7 [3.521]	69.2 [4.223]	80.6 [4.919]	92.1 [5.620]
SDA40×□-135	52.3 [3.192]	69.6 [4.247]	86.8 [5.297]	104.1 [6.353]	121.3 [7.402]	138.6 [8.458]
SDA40×□-180	69.7 [4.253]	92.7 [5.657]	115.7 [7.060]	138.6 [8.458]	161.6 [9.861]	184.6 [11.265]

## Cylinder Thrust

Select a suitable cylinder bore size considering the load and air pressure to obtain the required thrust.

Since the figures in the table are calculated values, select a bore size that results in a load ratio (load ratio =  $\frac{\text{Load}}{\text{Calculated value}}$ ) of 70% or less (50% or less for high speed application).

Model	Piston rod size mm [in.]	Operation	Pressure area mm <sup>2</sup> [in. <sup>2</sup> ]	Air pressure MPa [psi.]								
				0.1 [15]	0.2 [29]	0.3 [44]	0.4 [58]	0.5 [73]	0.6 [87]	0.7 [102]	0.8 [116]	0.9 [131]
SDA25×□-□	□7.4 [0.291]	Push side	490 [0.760]	49 [11]	98 [22]	147 [33]	196 [44]	245 [55]	294 [66]	343 [77]	392 [88]	441 [99]
		Pull side	436 [0.676]	43.6 [9.8]	87.2 [19.6]	130.8 [29.4]	174.4 [39.2]	218 [49.0]	261.6 [58.8]	305.2 [68.6]	348.8 [78.4]	392.4 [88.2]
SDA40×□-□	□13 [0.512]	Push side	1250 [1.938]	125 [28]	250 [56]	375 [84]	500 [112]	625 [141]	750 [169]	875 [197]	1000 [225]	1125 [253]
		Pull side	1087 [1.685]	108.7 [24.4]	217.4 [48.9]	326.1 [73.3]	434.8 [97.7]	543.5 [122.2]	652.2 [146.6]	760.9 [171.1]	869.6 [195.5]	978.3 [219.9]

# Swing CYLINDERS



## Specifications

Type Item	Basic type Specification angle	SDA25×□				SDA40×□				
		-45	-90	-135	-180	-45	-90	-135	-180	
Media		Air								
Operating pressure range	MPa [psi.]	0.2~0.7 [29~102]								
Proof pressure	MPa [psi.]	1.03 [149]								
Operating temperature range	°C [°F]	0~60 [32~140]								
Lubrication		Not required								
Cylinder portion	Operation type	Double acting type								
	Operating speed range	mm/s [in./sec.] 50~500 [2.0~19.7]								
	Cushion	On both sides (Rubber bumper)								
	Port size	Rc 1/8								
	Stroke tolerance	mm [in.] +1 [+0.039] 0 0								
Swing portion	Operation type	Double acting piston type with swing angle adjustment (Rack and pinion type)								
	Effective torque (at 0.5MPa [73psi.])	N·m [ft·lbf] 0.549 [0.405]				1.294 [0.954]				
	Swing angle range	20°~105°	45°~105°	100°~195°	135°~195°	20°~100°	80°~100°	100°~190°	170°~190°	
	Backlash	3.5°				2.5°				
	Swing time <sup>Note1</sup> (at 0.5MPa [73psi.] without load)	s	0.2~0.5	0.2~0.5	0.4~0.8	0.4~1.0	0.2~1.0	0.2~1.2	0.4~1.8	0.4~2.5
	Cushion	None								
	Bore size X stroke <sup>Note1</sup>	mm [in.]	16X6.3 [0.630X0.249]	16X12.6 [0.630X0.496]	16X18.9 [0.630X0.744]	16X25.2 [0.630X0.992]	20X9.4 [0.787X0.370]	20X18.8 [0.787X0.740]	20X28.3 [0.787X1.114]	20X37.7 [0.787X1.484]
	Allowable energy <sup>Note2</sup>	J [in·lbf]	0.002 (0.006) [0.018 (0.053)]				0.006 (0.02) [0.053 (0.18)]			
Port size	Rc	1/8								

Notes: 1. For the specification angle.

2. The allowable energy in ( ) is obtained when the rod end specification is square.

## Order Codes

**SDA** **25×50** - □ - □ - □ - □ - □ - □ - □ - □ - □

**Bore size X Stroke**

**Rod end specification**  
Blank — Male thread  
N — Square (with female thread)

**Swing cylinder**      **Swing angle**  
45 : 45°  
90 : 90°  
135 : 135°  
180 : 180°

**Mounting bracket**  
Blank — No mounting bracket  
3 — With flange mounting bracket  
● Mounting bracket is included at shipping.

**Number of sensor switches**  
1 — With 1 sensor switch  
2 — With 2 sensor switches

**Lead wire length**  
A : 1000mm [39in.]  
B : 3000mm [118in.]

**Sensor switch**  
● **Swing portion mounting**  
Blank — No sensor switch  
ZC130 — Solid state type 2-lead wire with indicator lamp DC10~28V  
ZC153 — Solid state type 3-lead wire with indicator lamp DC4.5~28V  
CS5T — Reed switch type 2-lead wire without indicator lamp DC5~28V AC85~115V  
CS11T — Reed switch type 2-lead wire with indicator lamp DC10~28V

**Number of sensor switches**  
1 — With 1 sensor switch  
2 — With 2 sensor switches  
3 — With 3 sensor switches  
: :  
: :

**Lead wire length**  
(Excluding CS□F)  
A : 1000mm [39in.]  
B : 3000mm [118in.]

**Sensor switch**  
● **Cylinder portion mounting**  
Blank — No sensor switch  
ZG530 — Solid state type 2-lead wire with indicator lamp DC10~28V  
ZG553 — Solid state type 3-lead wire with indicator lamp DC4.5~28V  
CS3M — Reed switch type 2-lead wire with indicator lamp DC10~30V AC85~230V  
CS4M — Reed switch type 2-lead wire with indicator lamp DC10~30V AC85~115V  
CS5M — Reed switch type 2-lead wire without indicator lamp DC3~30V AC85~115V  
CS2F — Reed switch type with indicator lamp AC85~230V  
CS3F — Reed switch type with indicator lamp DC10~30V  
CS4F — Reed switch type with indicator lamp DC10~30V  
CS5F — Reed switch type without indicator lamp DC3~30V

- Since all Swing cylinders are equipped with magnets beforehand, they can be used as cylinders with magnets only by mounting a sensor switch.
- CS□F comes with a DIN connector.
- All others are grommet type.
- For details of sensor switches, see p.1544.

## Inner Construction and Major Parts

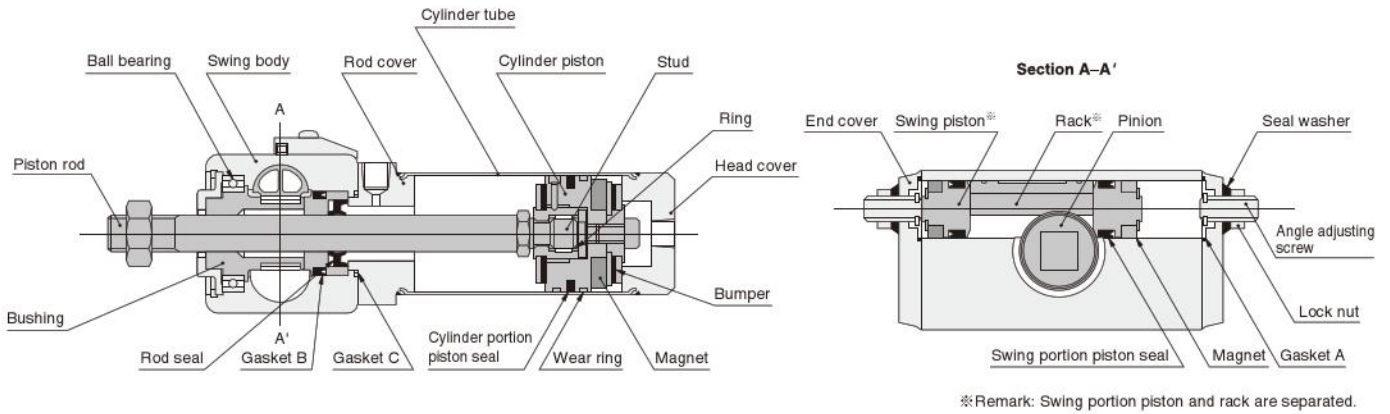

## Major Parts and Materials

### ● Cylinder portion

Parts	Materials
Cylinder tube	Stainless steel
Cylinder piston	Aluminum alloy (anodized)
Piston rod	Steel (hard chrome plated)
Rod cover	Aluminum alloy (anodized)
Head cover	
Stud	Steel (nickel plated )
Ring	Special steel (Plastic for <b>SDA25</b> )
Wear ring	Plastic
Seal	Synthetic rubber
Bumper	
Magnet	Plastic magnet

### ● Swing portion

Parts	Materials
Swing body	Aluminum alloy (anodized)
End cover	
Pinion bushing	Plastic
Rack	
Ball bearing	Bearing steel
Seal	Synthetic rubber
Magnet	Plastic magnet

## Bore Size and Stroke

Model	Standard strokes	mm
		Maximum available stroke
<b>SDA25</b> × □ - □	15 25 50	150
<b>SDA40</b> × □ - □	15 25 50 75 100	300

## Mass

Item	Model	kg [lb.]			
		<b>SDA25</b> × □ - <b>45, 90</b>	<b>SDA25</b> × □ - <b>135, 180</b>	<b>SDA40</b> × □ - <b>45, 90</b>	<b>SDA40</b> × □ - <b>135, 180</b>
Zero stroke mass		0.55 [1.21]	0.71 [1.57]	1.10 [2.43]	1.34 [2.95]
Additional mass for each 1mm [0.0394in.] stroke		0.0009 [0.0020]		0.0021 [0.0046]	
Mass of flange mounting bracket		0.17 [0.37]		0.23 [0.51]	
Mass of cylinder portion sensor switch	<b>ZG5</b> □ □, <b>CS</b> □ <b>M</b>	0.030 [0.066]			
	<b>CS</b> □ <b>F</b>	0.060 [0.132]			
Mass of swing portion sensor switch	<b>ZC1</b> □ □	0.022 [0.049]			
	<b>CS5T</b>	0.022 [0.049]			
	<b>CS11T</b>	0.022 [0.049]			

\* The sensor switch mass is the mass of 1 sensor switch including a holder.

Calculation example: Mass of **SDA25** × 50-90 with a flange mounting bracket and sensor switches (ZG530: 2 pcs., ZC130: 2 pcs.),  
 $0.55 + (0.0009 \times 50) + 0.17 + (0.030 \times 2) + (0.022 \times 2) = 0.869\text{kg} [1.916\text{lb.}]$

# Dimensions (mm)

## Basic type

CAD Swing angle 45°, 90° : SDA Bore size -1  
 Swing angle 135°, 180° : SDA Bore size -2

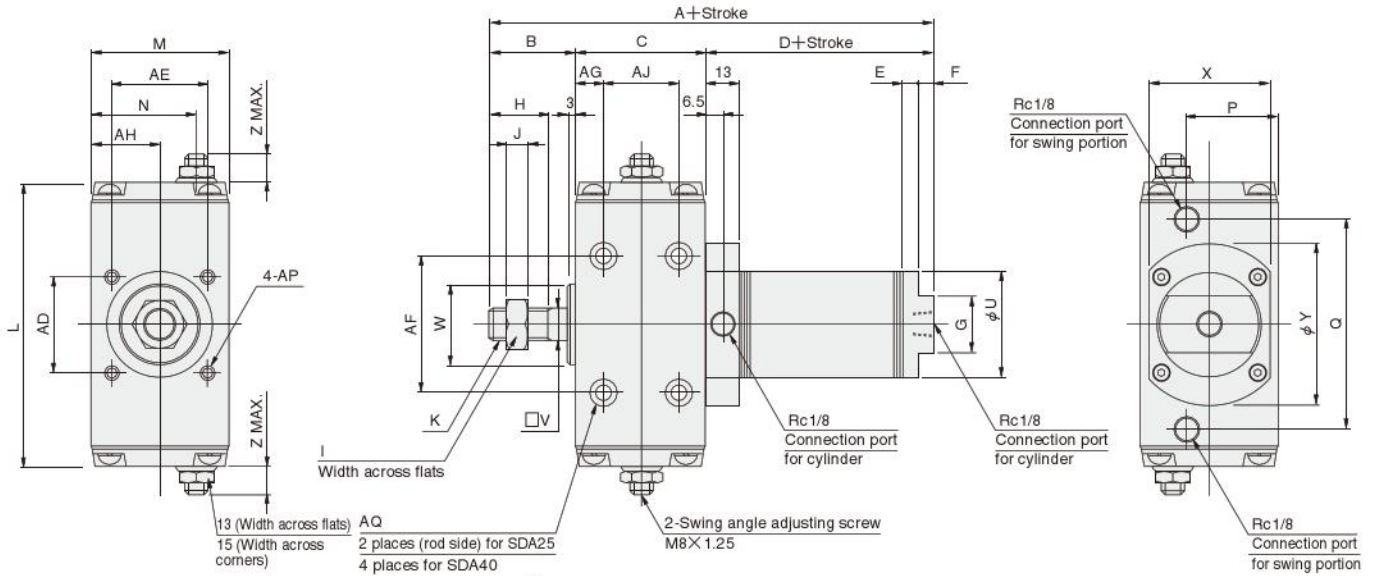

## Square rod end specification (-N)

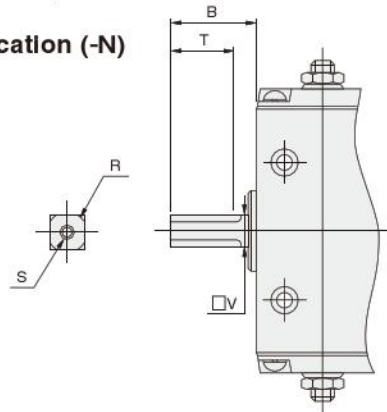

Note: Drawings show SDA40.

Model	Code	A	B	C	D	E	F	G	H	I	J	K	L	M	N
SDA25×□-45, SDA25×□-90		133	29	44	60	4	5	19	18	12	5	M8×1	90	44	34
SDA25×□-135, SDA25×□-180		133	29	44	60	4	5	19	18	12	5	M8×1	115	44	34
SDA40×□-45, SDA40×□-90		154	34	52	68	6	6	22	23	19	8	M14×1.5	112	54	41.5
SDA40×□-135, SDA40×□-180		154	34	52	68	6	6	22	23	19	8	M14×1.5	150	54	41.5

Model	Code	P	Q	R	S	T	U	V	W	X	Y	Z <sup>Note</sup>
SDA25×□-45, SDA25×□-90		30	63	φ 8 <sup>0</sup> <sub>-0.022</sub>	M4×0.7 Depth6	18	26.4	7.4	20	38	45	11.6 (18.6)
SDA25×□-135, SDA25×□-180		30	88	φ 8 <sup>0</sup> <sub>-0.022</sub>	M4×0.7 Depth6	18	26.4	7.4	20	38	45	11.6 (18.6)
SDA40×□-45, SDA40×□-90		36	83	φ 15 <sup>0</sup> <sub>-0.027</sub>	M6×1 Depth8	25	41.6	13	32	48	64	11.2 (18.2)
SDA40×□-135, SDA40×□-180		36	121	φ 15 <sup>0</sup> <sub>-0.027</sub>	M6×1 Depth8	25	41.6	13	32	48	64	11.2 (18.2)

Model	Code	AD	AE	AF	AG	AH	AJ	AP	AQ
SDA25×□-45, SDA25×□-90		25	25	42	8	22	—	M5×0.8 Depth10	φ 6.6 Counterbore φ 11 Depth6.3
SDA25×□-135, SDA25×□-180		25	25	42	8	22	—	M5×0.8 Depth10	φ 6.6 Counterbore φ 11 Depth6.3
SDA40×□-45, SDA40×□-90		38	38	54	11	27	30	M6×1 Depth10	φ 6.6 Counterbore φ 11 Depth6.3
SDA40×□-135, SDA40×□-180		38	38	54	11	27	30	M6×1 Depth10	φ 6.6 Counterbore φ 11 Depth6.3

Note : Figures in parentheses ( ) are for -45 and -135 models.

# Dimensions (mm)

## ● With flange mounting bracket

CAD Swing angle 45°, 90° : SDA Bore size -1  
 Swing angle 135°, 180° : SDA Bore size -2

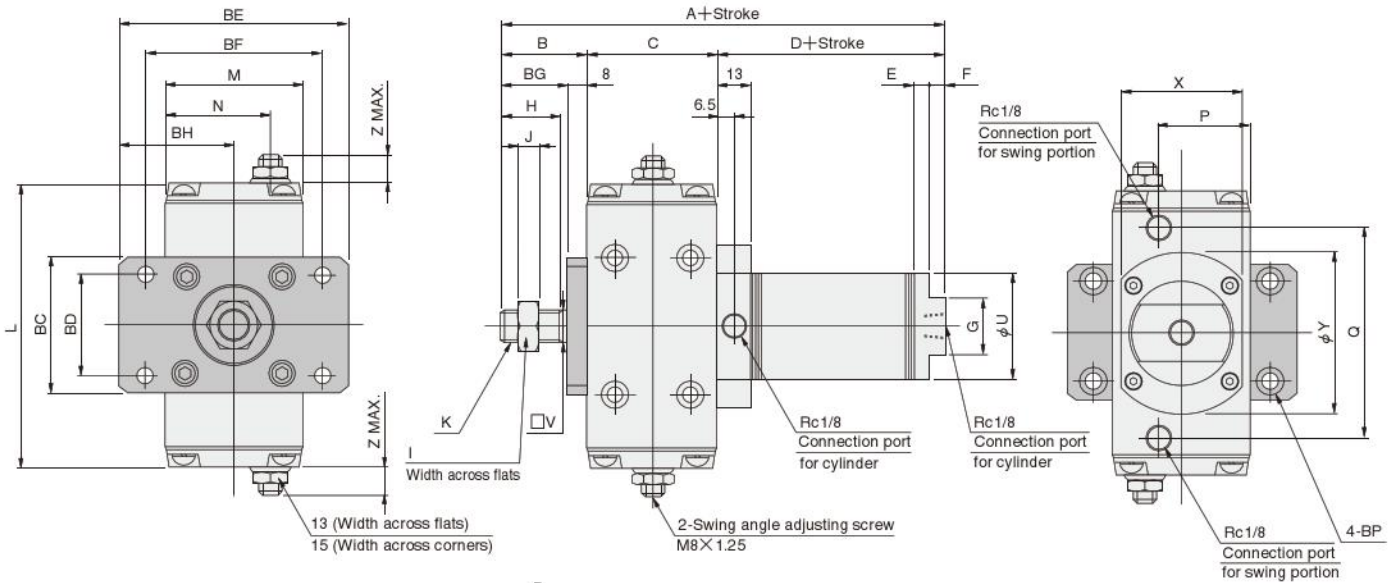

## ● Square rod end specification (-N)

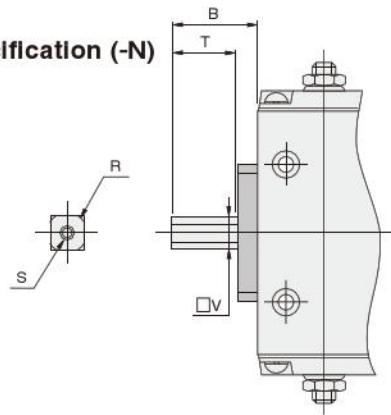

Note: Drawings show SDA40.

Model	Code	A	B	C	D	E	F	G	H	I	J	K	L	M	N
SDA25×□-45, SDA25×□-90		133	29	44	60	4	5	19	18	12	5	M8×1	90	44	34
SDA25×□-135, SDA25×□-180		133	29	44	60	4	5	19	18	12	5	M8×1	115	44	34
SDA40×□-45, SDA40×□-90		154	34	52	68	6	6	22	23	19	8	M14×1.5	112	54	41.5
SDA40×□-135, SDA40×□-180		154	34	52	68	6	6	22	23	19	8	M14×1.5	150	54	41.5

Model	Code	P	Q	R	S	T	U	V	X	Y	Z <sup>Note</sup>
SDA25×□-45, SDA25×□-90		30	63	$\phi 8_{-0.022}^0$	M4×0.7 Depth6	18	26.4	7.4	38	45	11.6 (18.6)
SDA25×□-135, SDA25×□-180		30	88	$\phi 8_{-0.022}^0$	M4×0.7 Depth6	18	26.4	7.4	38	45	11.6 (18.6)
SDA40×□-45, SDA40×□-90		36	83	$\phi 15_{-0.027}^0$	M6×1 Depth8	25	41.6	13	48	64	11.2 (18.2)
SDA40×□-135, SDA40×□-180		36	121	$\phi 15_{-0.027}^0$	M6×1 Depth8	25	41.6	13	48	64	11.2 (18.2)

Model	Code	BC	BD	BE	BF	BG	BH	BP
SDA25×□-45, SDA25×□-90		44	30	75	60	21	37.5	$\phi 5.5$ Counterbore $\phi 9.5$ Depth5.4
SDA25×□-135, SDA25×□-180		44	30	75	60	21	37.5	$\phi 5.5$ Counterbore $\phi 9.5$ Depth5.4
SDA40×□-45, SDA40×□-90		54	40	90	70	26	45	$\phi 6.5$ Counterbore $\phi 11$ Depth6.5
SDA40×□-135, SDA40×□-180		54	40	90	70	26	45	$\phi 6.5$ Counterbore $\phi 11$ Depth6.5

Note : Figures in parentheses ( ) are for -45 and -135 models.

# SENSOR SWITCHES

Solid State Type, Reed Switch Type

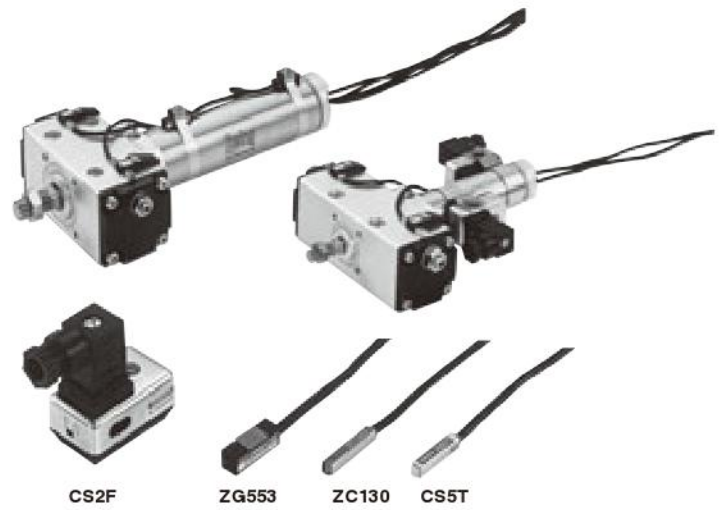

## Minimum Cylinder Stroke When Mounting Sensor Switches

### Minimum cylinder stroke for sensor switch mounting

Sensor switch model	Mounting 2 pcs.		Mounting 1 pc.
	On straight line	When position is staggered	
ZG530 ZG553	20	15	15
CS□M	20	15	15
CS□F	44	21	15

### ● Mounting 1 pc.

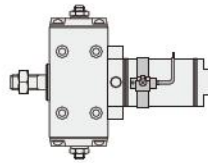

### ● Mounting 2 pcs.

#### ● When mounting straight

#### ● When mounting on the staggered position

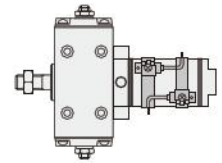
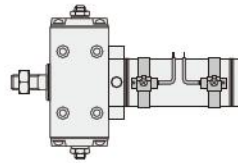

## Order Codes for Sensor Switches

### ■ Swing portion (with mounting bracket)

			Sensor switch model	Lead wire length	Basic type	Bore size
Solid state type 2-lead wire	with indicator lamp	DC10~28V	ZC130	A B	-SDA	25 [0.984in.]
Solid state type 3-lead wire	with indicator lamp	DC4.5~28V	ZC153			
Reed switch type 2-lead wire	without indicator lamp	DC5~28V AC85~115V	CS5T	A B	-SDA	40 [1.575in.]
Reed switch type 2-lead wire	with indicator lamp	DC10~28V	CS11T			

### ■ Cylinder portion (with mounting bracket)

			Sensor switch model	Lead wire length	Basic type	Bore size
Solid state type 2-lead wire	with indicator lamp	DC10~28V	ZG530	A B	-SDA	25 [0.984in.]
Solid state type 3-lead wire	with indicator lamp	DC4.5~28V	ZG553			
Reed switch type 2-lead wire	with indicator lamp	DC10~30V AC85~230V	CS3M	A B	-SDA	25 [0.984in.]
Reed switch type 2-lead wire	with indicator lamp	DC10~28V AC85~115V	CS4M			
Reed switch type 2-lead wire	with indicator lamp	DC3~30V AC85~115V	CS5M	A B	-S	40 [1.575in.]
Reed switch type	with indicator lamp	AC85~230V	CS2F			
Reed switch type	with indicator lamp	DC10~30V	CS3F	A B	-S	40 [1.575in.]
Reed switch type	with indicator lamp	DC10~30V	CS4F			
Reed switch type	without indicator lamp	DC3~30V	CS5F	A B	-S	40 [1.575in.]

### ● Order codes for mounting bracket only (Swing portion)

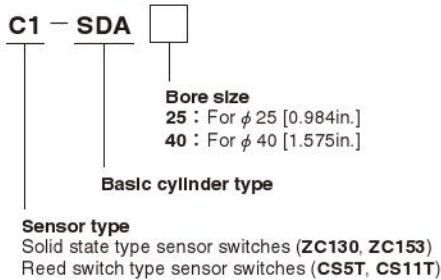

### ● Order codes for mounting strap only (Cylinder portion)

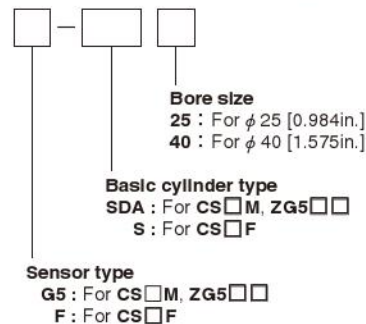

# Sensor Switch Operating Range, Response Differential, and Maximum Sensing Location

## ● Operating range: $\ell$

The distance the piston travels in one direction, while the switch is in the ON position.

## ● Response differential: C

The distance between the point where the piston turns the switch ON and the point where the switch is turned OFF as the piston travels in the opposite direction.

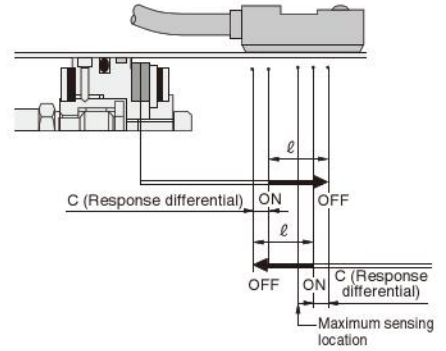

## ● Cylinder portion

Sensor switch model	CS□M	ZG5□□	CS□F
Operating range : $\ell$	7~10.5 [0.276~0.413]	2.5~4.2 [0.098~0.165]	8~12 [0.315~0.472]
Response differential : C	1 [0.039] MAX.	0.7 [0.028] MAX.	1.5 [0.059] MAX.
Maximum sensing location	11 [0.433] <sup>Note1</sup>	11 [0.433] <sup>Note1</sup>	16 [0.630] <sup>Note2</sup>

Notes: 1. This is the length measured from the switch's opposite end side to the lead wire.  
2. This is the length measured from the connector side end surface.

## ● Swing portion

Sensor switch model	CS5T	CS11T	ZC1□□
Operating range : $\ell$	7~9.5 [0.276~0.374]	2.5~4 [0.098~0.157]	2.5~4 [0.098~0.157]
Response differential : C	1.5 [0.059] MAX.	0.2 [0.008] MAX.	0.2 [0.008] MAX.
Maximum sensing location <sup>Note</sup>	7 [0.276]	10.5 [0.413]	8.5 [0.335]

Note: This is the length measured from the switch's opposite end side to the lead wire.

## Dimensions (mm)

### ● Cylinder portion

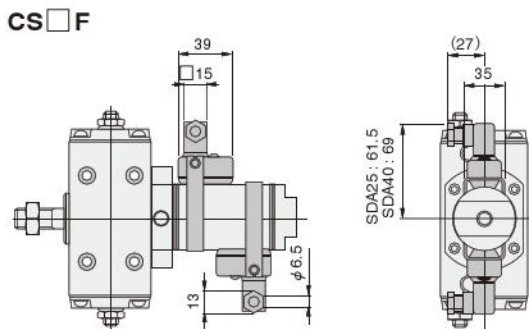
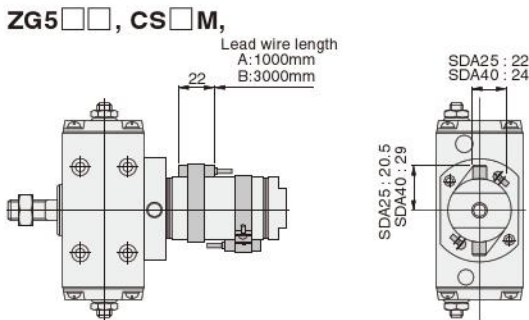

### ● Swing portion

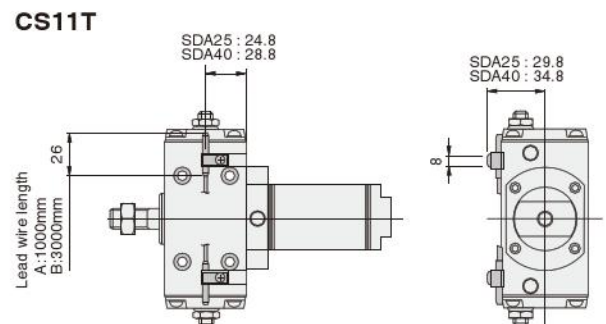
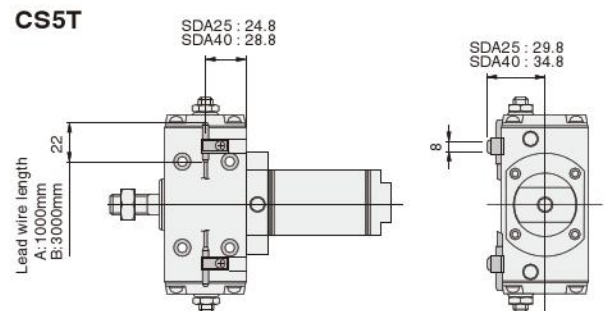
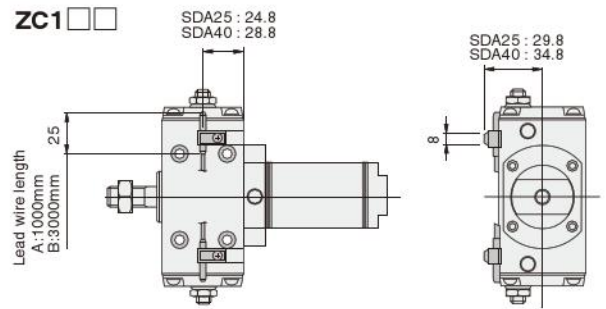



## Selection and swing angle

### Selection

1. Allow plenty of margin for swing output (torque). Select a model so that the required torque is 80% or less (50% or less for fluctuating loads) of the effective torque. The inertia load in swing operation becomes larger when the load mass is large, or during fast operating speeds, and it may exceed the allowable kinetic energy. In this case, install a shock absorber to prevent the Swing cylinder from being directly applied to inertia force.
2. Swing cylinders can have swing angles of 45°, 90°, 135°, or 180°, and swing angle adjustment is allowed within the ranges shown in the table below.

Model	Swing angle range
SDA25 X□-45	20°~105°
SDA25 X□-90	45°~105°
SDA25 X□-135	100°~195°
SDA25 X□-180	135°~195°
SDA40 X□-45	20°~100°
SDA40 X□-90	80°~100°
SDA40 X□-135	100°~190°
SDA40 X□-180	170°~190°

- Cautions:**
1. The cylinder may be damaged if the kinetic energy is too large. Always use it under the maximum allowable energy.
  2. For details concerning kinetic energy, see the separate literature "Rotary Actuator Selection Materials."

### Mounting

Although there is no particular restriction on mounting direction, ensure in vertical mountings that the piston rod and the load's applying point are aligned, and avoid applying off centered load. In addition, lateral loads on the piston rod should be at or below the values in the table below.

#### Allowable lateral load

N [lbf.]

Model	Stroke mm				
	15	25	50	75	100
SDA25	6.9 [1.55]	5.9 [1.33]	4.9 [1.10]	—	—
SDA40	16.7 [3.75]	15.7 [3.53]	13.7 [3.08]	11.8 [2.65]	9.8 [2.20]

- Cautions:**
1. Since a large radial load, moment, eccentricity of rotating rod, or an excessive inertia load, could cause inaccurate operation, or damage to the swing cylinder, always take appropriate countermeasures.
  2. There is a certain amount of backlash between the piston rod and bushing, which could result in deflection during swings. Note that deflection will increase at longer strokes or when lateral loads are applied.

### Swing angle adjustment and swing time

1. The flat surface of the piston rod has been adjusted as follows at shipping.

[90° and 180° specifications]

The flat surface of the piston rod at both swing ends is parallel to the plane of the swing portion's mounting surface.

[45° and 135° specifications]

Locate the mounting surface of the swing portion's sensor switch faces up, and set as shown in the diagrams below when it is at the left swing end, as viewed from the piston rod.

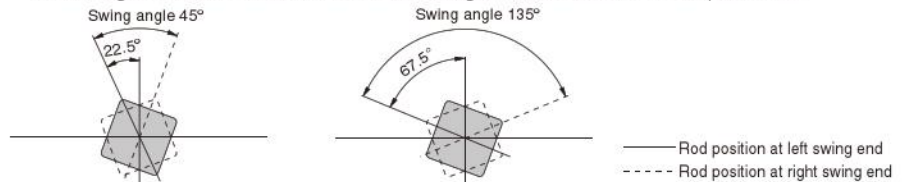

Remark: To designate piston rod position relationships at swing angles or swing ends other than those diagrams above, consult us.

2. The swing angle is easily adjustable on the Swing cylinders. Loosening the lock nut and turning the adjusting screw to the right (clockwise) makes the swing angle smaller, while turning it to the left (counterclockwise) makes the swing angle larger.

#### SDA25

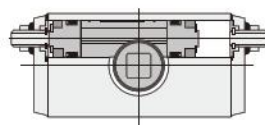

90° specification (45°~105°)

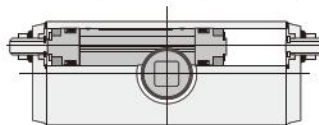

180° specification (135°~195°)

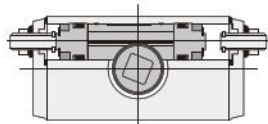

45° specification (20°~105°)

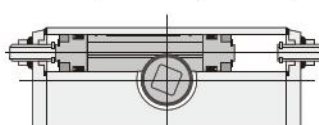

135° specification (100°~195°)

#### SDA40

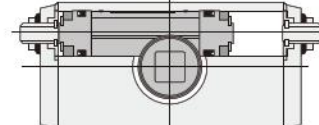

90° specification (80°~100°)

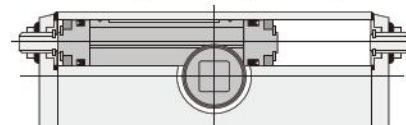

180° specification (170°~190°)

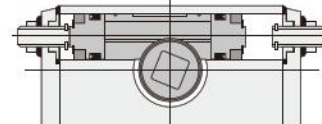

45° specification (20°~100°)

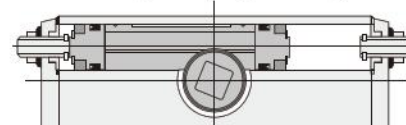

135° specification (100°~190°)

Remark: The above diagrams show the state with the swing portion at the left swing end (as adjusted at shipping).

Note: The swing angle ranges in parentheses show the minimum and maximum angles at which the angle can be adjusted with the swing angle adjusting screw. Care must be exercised, however, that the swing angle adjusting screw will protrude far from the body when adjusted to the maximum swing angle. Use close to the specification angle as much as possible.

In adjusting the swing angle to increase, however, do not let the adjusting screw protrude farther from the end surface of the swing portion shown in the table below.

Model	mm [in.]	
	45°, 135°	90°, 180°
SDA25	18.6 [0.732]	11.6 [0.457]
SDA40	18.2 [0.717]	11.2 [0.441]

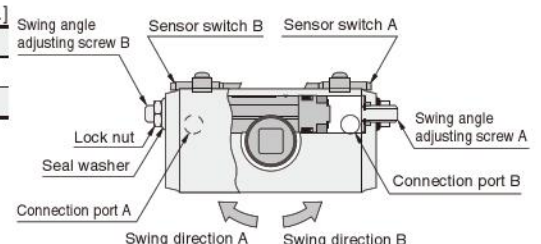

Supplying air to connection port A swings it to the direction A, and turns ON sensor switch A. On the other hand, supplying air to connection port B swings it to the direction B, and turns ON sensor switch B.



## Sensor switches



## General precautions

- Use the table below as a guide for the swing time (the time from the start of the swing to the end of the swing).

Swing time at 0.5MPa air pressure without load  $s$

Model	Swing time			
	45°	90°	135°	180°
SDA25	0.2~0.5	0.2~0.5	0.4~0.8	0.4~1.0
SDA40	0.2~1.0	0.2~1.2	0.4~1.8	0.4~2.5

- Cautions:**
- The swing cylinder has a maximum backlash (play at swing end) of 3.5° for SDA25 and 2.5° for SDA40. For cases requiring precise positioning, install an external stopper, etc.
  - The recommended tightening torque for the lock nut is about 392N·cm [34.7in·lbf]. For tightening, use a 13mm [0.512in.] standard wrench. Avoid using monkey wrenches, etc. The end cover may be damaged if excessively tightened.
  - When using reed type sensor switches on a swing portion, the sensor switch may malfunction during long swing time application. For low speed operations, use a solid state type sensor switch.

**Remarks:** In addition to the standard specifications, the Swing cylinders series in the following specifications are available.

- No-backlash at swing end type
  - Double swing torque type (no-backlash at swing end)
- For details, consult us.

### Mounting location and moving

#### ● Cylinder portion

When a sensor switch is mounted in the locations shown below, the magnet comes to the maximum sensing location of the sensor switch at the end of the stroke. By loosening the mounting screw, the sensor switch can be moved freely, along with the strap, in either the axial or circumferential directions. Cannot move the sensor switch alone.

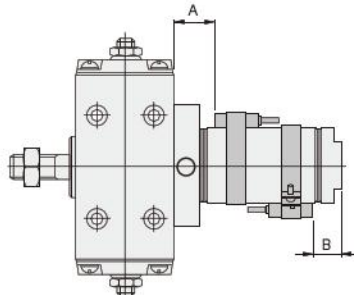

Mounting location of end of stroke detection sensor switch: A, B

Cylinder type	Sensor switch type			
	ZG5□□,CS□M		CS□F	
	A	B	A	B
SDA25 X□□	27 [1.06]	12 [0.47]	21 [0.83]	7 [0.28]
SDA40 X□□	31 [1.22]	16 [0.63]	25 [0.98]	11 [0.43]

**Caution:** For the sensor switch tightening torques, use the values listed below.  
 ZG5□□,CS□M — 49N·cm [4.3in·lbf]  
 CS□F — 68.6N·cm [6.1in·lbf]

#### ● Swing portion

When a sensor switch is mounted in the locations shown below, the magnet comes to the maximum sensing location of the sensor switch at the swing end.

To move the sensor switch, loosen the holder setscrew.

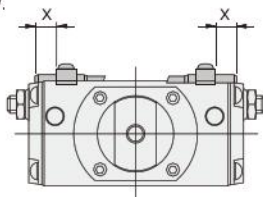

(The diagram shows a view from the head cover side)

Mounting location of sensor switch for specified angle detection: X

Cylinder model	Sensor switch type		
	CS5T	CS11T	ZC1□□
SDA25 X□-45, 135	6 [0.236]	9.5 [0.374]	7.5 [0.295]
SDA25 X□-90, 180	9 [0.354]	12.5 [0.492]	10.5 [0.413]
SDA40 X□-45, 135	4.5 [0.177]	8 [0.315]	6 [0.236]
SDA40 X□-90, 180	9.5 [0.374]	13 [0.512]	11 [0.433]

**Cautions:**

- Set the holder mounting screw's tightening torque to 29.4N·cm [2.6in·lbf], as follows.  
 When the swing angle is adjusted to 60° or less, the left and right sensor switches may detect (turn on) at the same time, due to relationships of the sensor switch operating range and response differential. To prevent this, take one of the following measures.

- Set just one of either the left or right sensor switches.

### Piping

Always thoroughly blow off (use compressed air) the tubing before connecting it to the Swing cylinder. Entering metal chips, sealing tape, rust, etc., generated during piping work could result in air leaks or other defective operation.

### Atmosphere

- If using in locations subject to dripping water, dripping oil, etc., or to large amounts of dust, use a cover to protect the unit.
- The product cannot be used when the media or ambient atmosphere contains any of the substances listed below.  
 Organic solvents, phosphate ester type hydraulic oil, sulphur dioxide, chlorine gas, or acids, etc.

### Lubrication

The product can be used without lubrication, if lubrication is required, use Turbine Oil Class 1 (ISO VG32) or equivalent.

Avoid using spindle oil or machine oil.

### Media

- Use air for the media. For the use of any other media, consult us.
- Air used for the Swing cylinder should be clean air that contains no deteriorated compressor oil, etc. Install an air filter (filtration of a minimum 40 μm) near the Swing cylinder or valve to remove collected liquid or dust. In addition, drain the air filter periodically.

- Set the sensor switch to a location just off of the maximum sensing location (but still within the operating range) for detection.

- The small piston strokes in the swing portion can make it impossible to accurately detect the swing angle.

If precise angle detection is required, use an external limit switch, etc., for detection.

- Since the rack and piston (magnet) are separate parts, moving the piston rod without applying air pressure may cause the sensor switches at both swing ends to enter the ON state. When checking operation of the swing portion sensor switches, always apply air pressure to check.

- If an external stopper, etc., is limiting the swing angle, care must be exercised that sensor switches in the above adjusting ranges may fail to operate.

#### ● Caution when installing a sensor switch on the cylinder

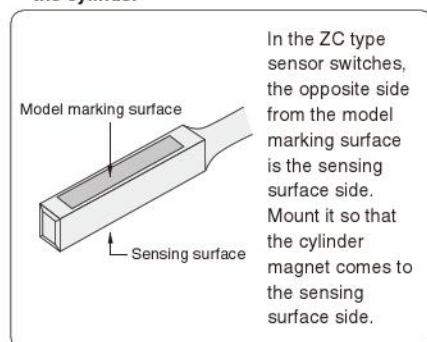

In the ZC type sensor switches, the opposite side from the model marking surface is the sensing surface side. Mount it so that the cylinder magnet comes to the sensing surface side.