

SPEED CONTROLLERS SC SERIES

M5×0.8, Rc1/8

- Compact and lightweight, optimum for Pen Cylinders, Jig Cylinders, and Slim Cylinders.
- Straight type and L type offer mounting in any direction.
- Union type allows piping and needle setting in any direction.

Symbol

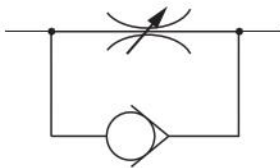

Specifications

Item	Model	SC0	SC0-F	SC0-US	SC0-UL	SC1	SC2
Piping type		Female thread	Male thread	Union male thread Straight Elbow		Female thread	
Port size		M5×0.8					Rc1/8
Operating pressure range	MPa [psi.]	0~0.9 [0~131]					
Proof pressure	MPa [psi.]	1.32 [191]					
Cracking pressure	MPa [psi.]	0.05 [7.3]				0.04 [5.8]	0.03 [4.4]
Operating temperature range	°C [°F]	5~60 [41~140]					
Mass	g [oz.]	30 [1.06]	35 [1.23]	36 [1.27]	88 [3.10]	55 [1.94]	

Order Codes

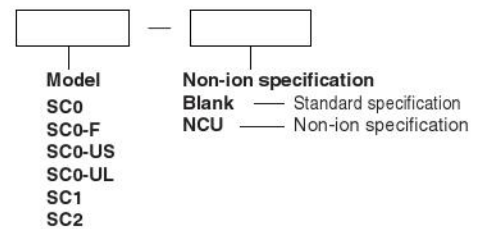

Inner Construction and Major Parts

● SC0

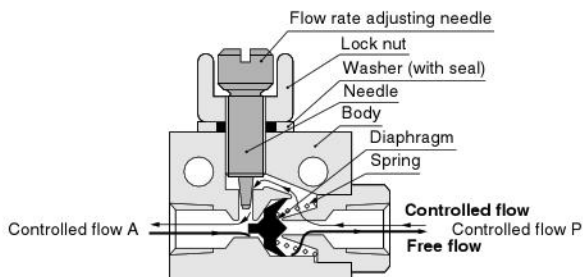

● SC1

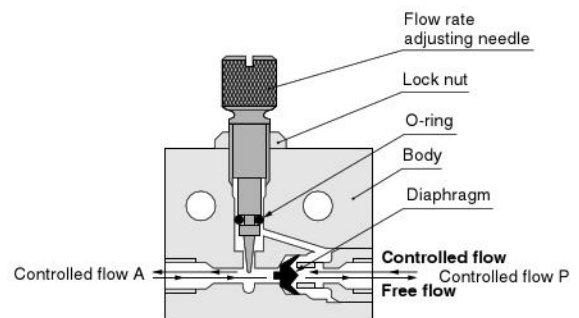

● SC2

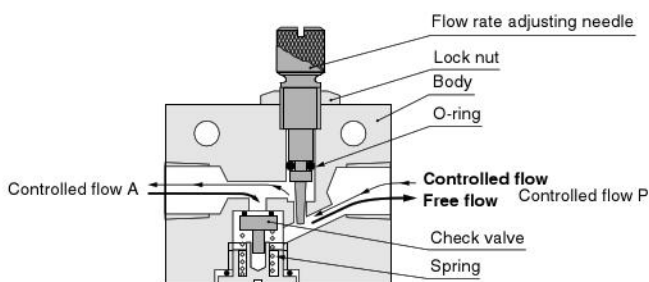

Major Parts and Materials

Parts	Materials
Body	Brass (nickel plated) ^{*)}
Needle	Stainless steel
Lock nut	Brass (nickel plated)
Check valve	Synthetic rubber (NBR)
O-ring	
Flow rate adjusting needle	Brass (nickel plated)

Note :SC2 is made of aluminum alloy (anodized).

Dimensions (mm)

● SC0

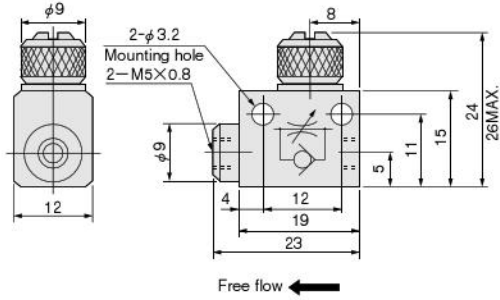

● SC0-US

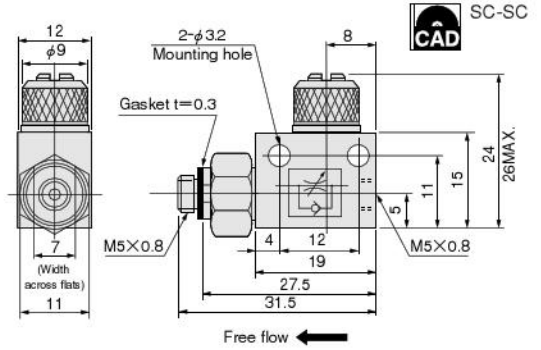

● SC0-F

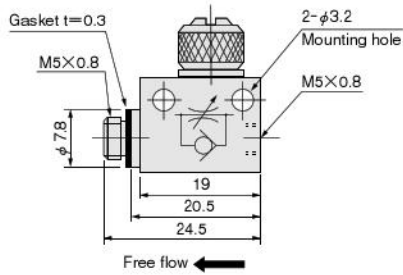

● SC0-UL

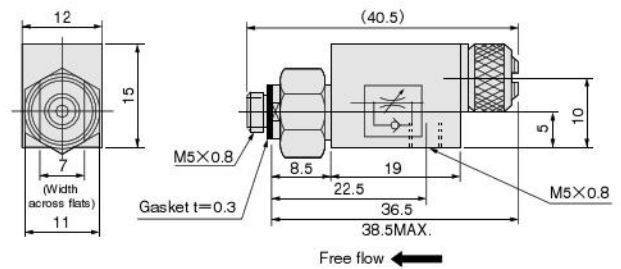

● SC1

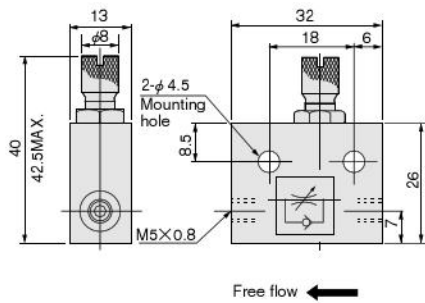

● SC2

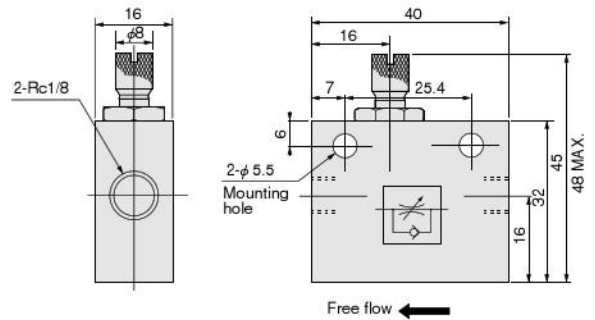

Flow Rate Characteristics

● SC0

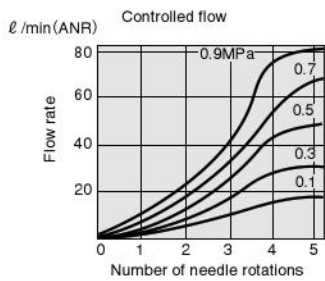

● SC1

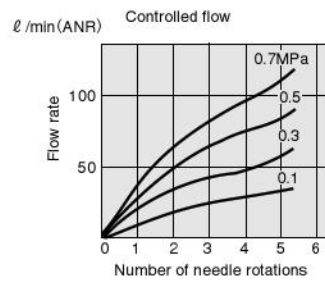

● SC2

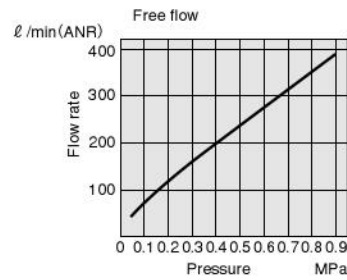
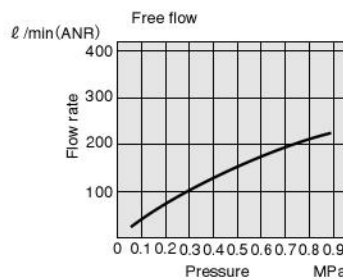
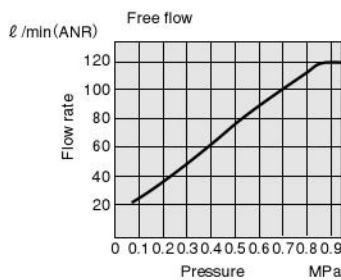
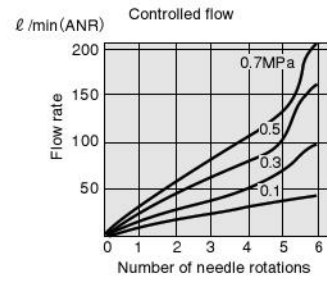

1MPa = 145psi.
1 ℓ/min = 0.0353ft³/min.