

KOGANEI

ACCESSORIES GENERAL CATALOG

AIR TREATMENT, AUXILIARY, VACUUM,
AND FLUORORESIN PRODUCTS

REGULATORS WITH QUICK FITTINGS CONTENTS



Specifications, Order Codes, Size Table	457
Dimensions	458
Flow Rate Characteristics, Pressure Characteristics (Straight, Elbow)	460
Flow Rate Characteristics, Pressure Characteristics (Elbow with Pressure Gauge)	462
NCU Specification Order Codes, Model Table	464
Safety Precautions, Handling Instructions and Precautions	465

REGULATORS WITH QUICK FITTINGS

 **Caution** Before use, be sure to read the "Safety Precautions" on p. 49.

REGULATORS WITH QUICK FITTINGS

Standard Type Pressure Gauge Type

- Reduce media pressure, and supply media from the fitting port.
- Convenient built-in quick fittings offer compact design.
- Also available with pressure gauge for quick pressure confirmation.

Symbols

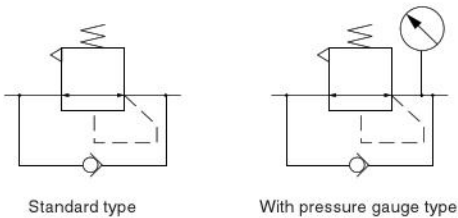

Specifications

Media	Air
Operating pressure range	0~0.9MPa [0~131psi.]
Pressure setting range	0.1~0.8MPa [14.5~116psi.]
Indication pressure range	0~0.8MPa [0~116psi.]
Accuracy (Pressure gauge)	±5% (full-scale)
Operating temperature range	0~60°C [32~140°F]
Recommended tube	Nylon tube, urethane tube
Sales unit	1 pc.

Remark: Supplied with a gasket or sealant coated.

Inner Construction, Major Parts and Materials

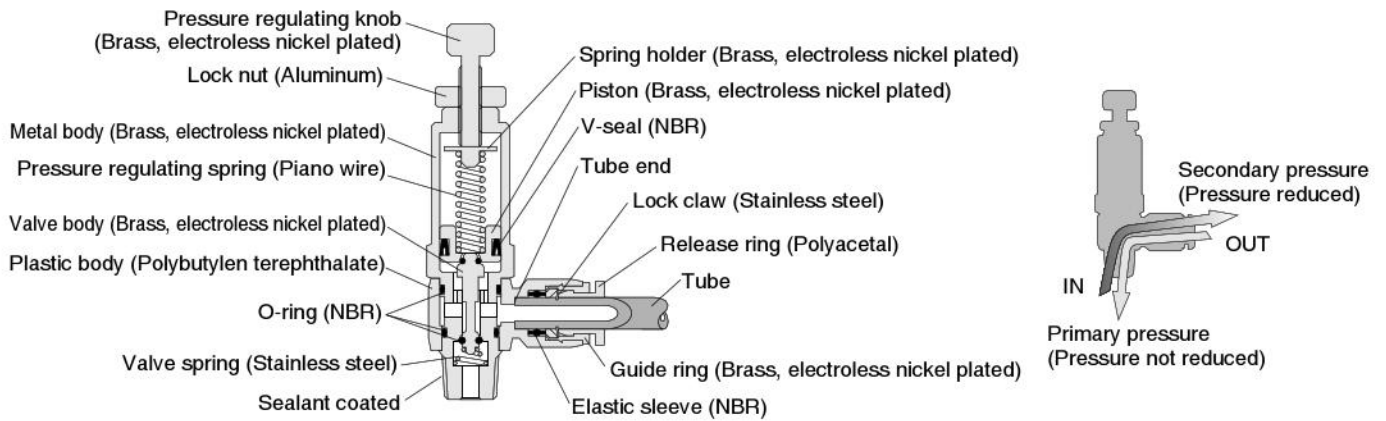

Order Codes

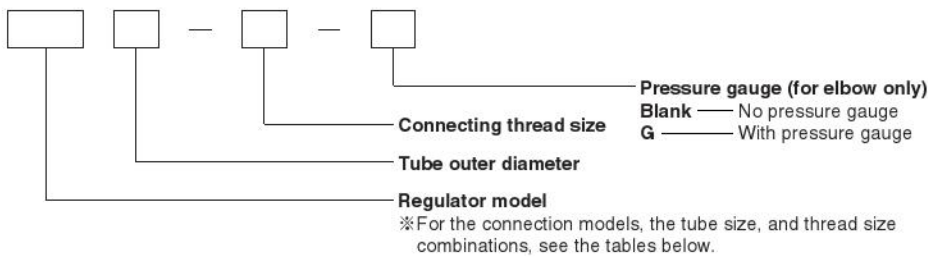

● For the NCU specification, see p.464.

● RTS Straight 458



Tube size	Thread size		
	M5×0.8	R1/8	R1/4
4	M5	01	—
6	M5	01	02
8	—	01	02

● RTL Elbow 458



Tube size	Thread size		
	M5×0.8	R1/8	R1/4
4	M5	01	—
6	M5	01	02
8	—	01	02

● RTL-G

Elbow with pressure gauge 459



Tube size	Thread size		
	M5×0.8	R1/8	R1/4
4	M5	01	—
6	M5	01	02
8	—	01	02

Dimensions (mm)

Straight RTS

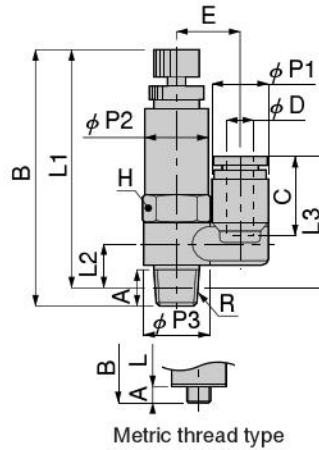

Model	Tube outer diameter ϕD	R	A	B		L1 ^{Note}		L2 ^{Note}	L3 ^{Note}	$\phi P1$	$\phi P2$	$\phi P3$	C	E	Width across flats H	Mass (g) [oz.]
				MAX	MIN	MAX	MIN									
RTS4-M5	4	M5X0.8	2.9	48.7	44.6	45.8	41.7	7.7	24.8	10.2	10	9.8	14.9	10.5	10	18 [0.63]
RTS4-01		R1/8	7.8	60	56	56	52	10.7	28.7		14	14.4		13	14	37 [1.31]
RTS6-M5	6	M5X0.8	2.9	48.7	44.6	45.8	41.7	7.7	26.9	12.6	10	9.8	17	12.2	10	18 [0.63]
RTS6-01		R1/8	7.8	60	56	56	52	10.7	30.8		14	14.4		14.2	14	38 [1.34]
RTS6-02		R1/4	11.3	64.8	60.8	58.8	54.8	12	32.1		17	18.4		17.2	17	60 [2.12]
RTS8-01	8	R1/8	7.8	60	56	56	52	10.7	32.2	14.6	14	14.4	18.1	15.2	14	39 [1.38]
RTS8-02		R1/4	11.3	64.8	60.8	58.8	54.8	12	33.6		17	18.4		18.2	17	62 [2.19]

Note: The L1, L2 and L3 dimensions for the taper thread type are the reference dimensions after the fittings are assembled.

Elbow RTL

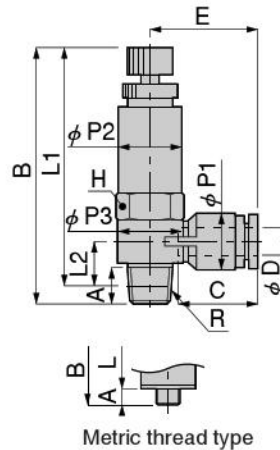

Model	Tube outer diameter ϕD	R	A	B		L1 ^{Note}		L2 ^{Note}	$\phi P1$	$\phi P2$	$\phi P3$	C	E	Width across flats H	Mass (g) [oz.]
				MAX	MIN	MAX	MIN								
RTL4-M5	4	M5X0.8	2.9	48.7	44.6	45.8	41.7	7.6	8	10	9.8	11	15.4	10	16 [0.56]
RTL4-01		R1/8	7.8	60	56	56	52	10.5	10	14	14.4	14.9	21.4	14	36 [1.27]
RTL6-M5	6	M5X0.8	2.9	48.7	44.6	45.8	41.7	8.4	10.5	10	9.8	11.6	17.5	10	16 [0.56]
RTL6-01		R1/8	7.8	60	56	56	52	10.7	12.4	14	14.4	17	23.5	14	36 [1.27]
RTL6-02		R1/4	11.3	64.8	60.8	58.8	54.8	12.2		17	18.4		25.5	17	59 [2.08]
RTL8-01	8	R1/8	7.8	60	56	56	52	11.7	14.4	14	14.4	18.1	26.9	14	38 [1.34]
RTL8-02		R1/4	11.3	64.8	60.8	58.8	54.8	13.2		17	18.4		28.4	17	60 [2.12]

Note: The L1 and L2 dimensions for the taper thread type are the reference dimensions after the fittings are assembled.

Dimensions (mm)

Elbow with pressure gauge RTL-G

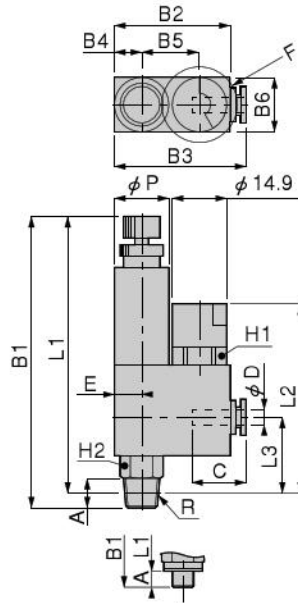

Metric thread type

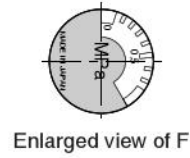

Model	Tube outer diameter ϕD	R	A	B1		B2	B3	B4	B5	B6	L1 ^{Note}		L2 ^{Note}	L3 ^{Note}	C	E	ϕP	Width across flats H1	Width across flats H2	Mass (g) [oz.]
				MAX	MIN						MAX	MIN								
RTL4-M5-G	4	M5X0.8	3	60.6	56.6	24.8	27.4	5.8	13.7	15.1	57.6	53.6	42.8	11.8	11	4.7	11	14	8	28 [0.99]
RTL4-01-G		R1/8	7.8	81.8	77.4	32	36.2	7.8	15.8	15	77.8	73.4	51.6	18.6	15.9	7.3	15.2		12	55 [1.94]
RTL6-M5-G	6	M5X0.8	3	60.6	56.6	24.8	27.8	5.8	13.7	15.1	57.6	53.6	42.8	11.8	11.6	4.7	11	14	8	28 [0.99]
RTL6-01-G		R1/8	7.8	81.8	77.4	32	36.8	7.8	15.8	15	77.8	73.4	51.6	18.6	17	7.3	15.2		12	56 [1.98]
RTL6-02-G		R1/4	11.3	90	85.7	35.1	39.9	9.9	17.7	19.1	84	79.7	57.3	22.8		8.7	19.1		16	16
RTL8-01-G	8	R1/8	7.8	81.8	77.4	32	36.7	7.8	15.8	15	77.8	73.4	51.6	18.6	18.1	7.3	15.2	14	12	56 [1.98]
RTL8-02-G		R1/4	11.3	90	85.7	35.1	39.8	9.9	17.7	19.1	84	79.7	57.3	22.8		8.7	19.1	12	16	85 [3.00]

Note: The L1, L2 and L3 dimensions for the taper thread type are the reference dimensions after the fittings are assembled.

Flow Rate Characteristics, Pressure Characteristics (Straight, Elbow)

RTS4-M5 RTL4-M5
 RTS6-M5 RTL6-M5

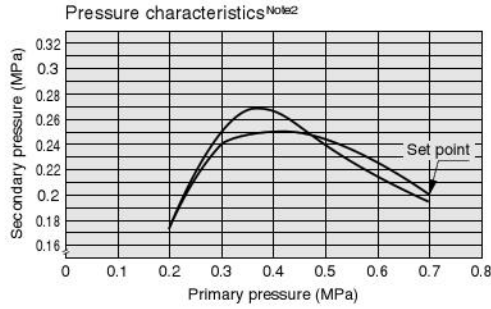
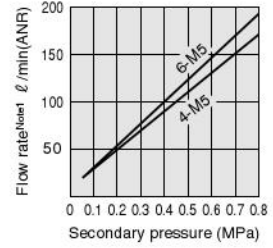
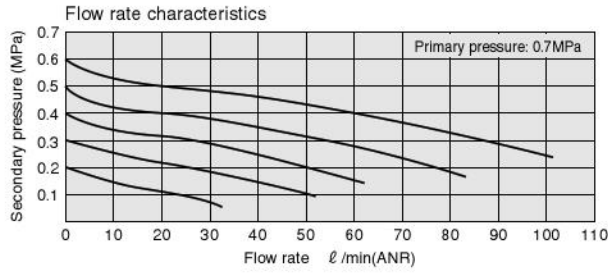

Notes: 1. Flow rate comes from secondary to primary pressure flow.
 2. Primary pressure changes from 0.7MPa to 0.2MPa to 0.7MPa.

1MPa = 145psi. 1 l/min = 0.0353ft³/min.

RTS4-01 RTL4-01
 RTS6-01 RTL6-01
 RTS8-01 RTL8-01

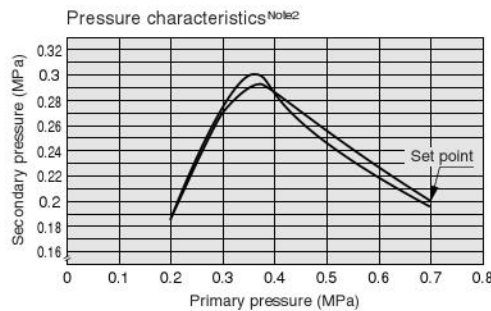
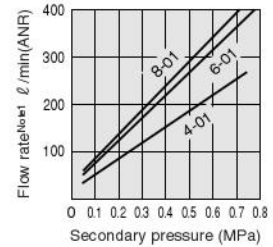
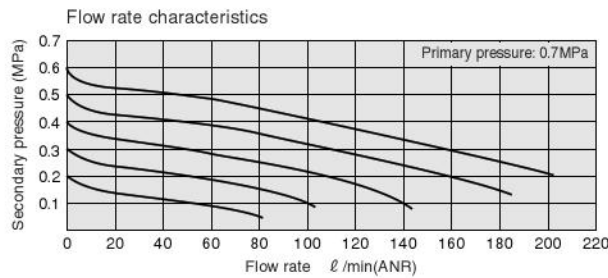

Notes: 1. Flow rate comes from secondary to primary pressure flow.
 2. Primary pressure changes from 0.7MPa to 0.2MPa to 0.7MPa.

1MPa = 145psi. 1 l/min = 0.0353ft³/min.

Flow Rate Characteristics, Pressure Characteristics (Straight, Elbow)

RTS6-02 RTL6-02
 RTS8-02 RTL8-02

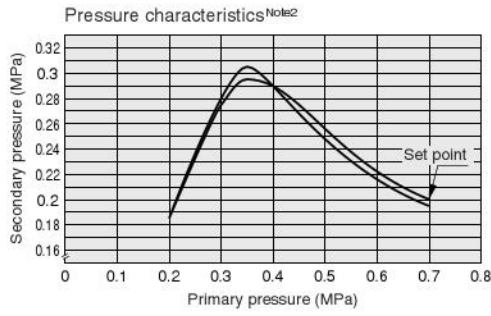
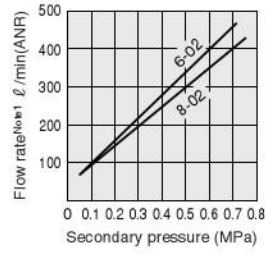
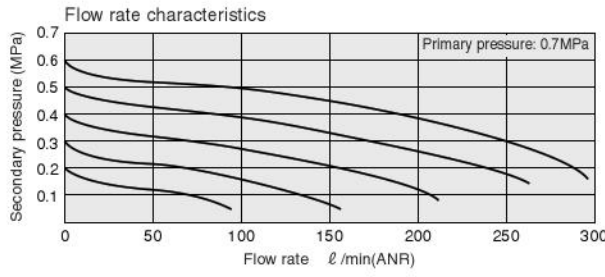

Notes: 1. Flow rate comes from secondary to primary pressure flow.
 2. Primary pressure changes from 0.7MPa to 0.2MPa to 0.7MPa.

1MPa = 145psi. 1 ℓ /min = 0.0353ft³/min.

Flow Rate Characteristics, Pressure Characteristics (Elbow with Pressure Gauge)

RTL4-M5-G RTL6-M5-G

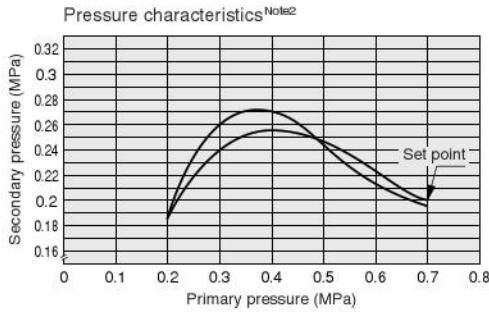
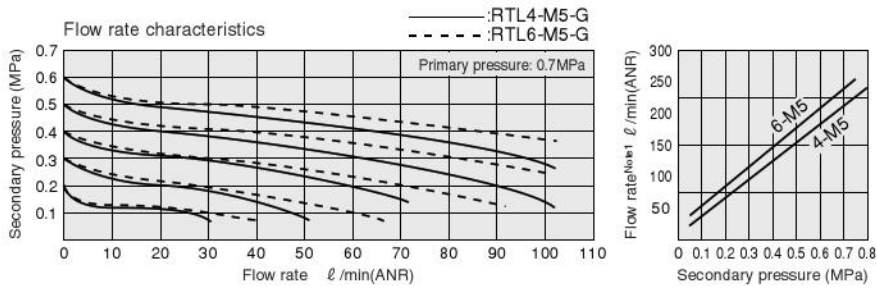

Notes: 1. Flow rate comes from secondary to primary pressure flow.
2. Primary pressure changes from 0.7MPa to 0.2MPa to 0.7MPa.

1MPa = 145psi. 1 ℓ /min = 0.0353ft³/min.

RTL4-01-G RTL6-01-G RTL8-01-G

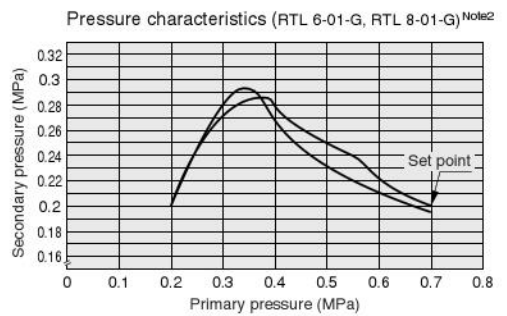
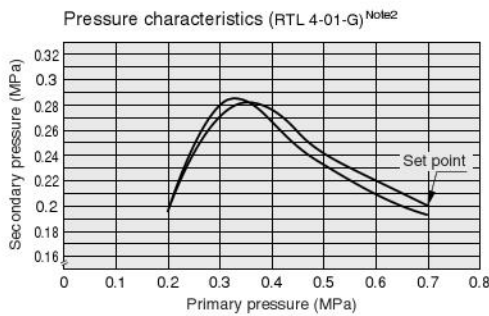
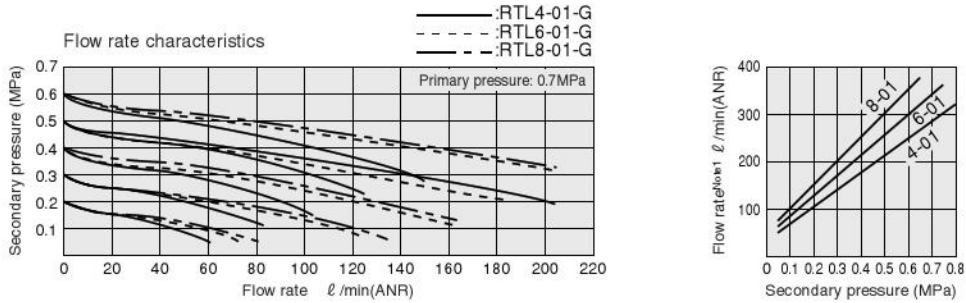

Notes: 1. Flow rate comes from secondary to primary pressure flow.
2. Primary pressure changes from 0.7MPa to 0.2MPa to 0.7MPa.

1MPa = 145psi. 1 ℓ /min = 0.0353ft³/min.

Flow Rate Characteristics, Pressure Characteristics (Elbow with Pressure Gauge)

RTL6-02-G
RTL8-02-G

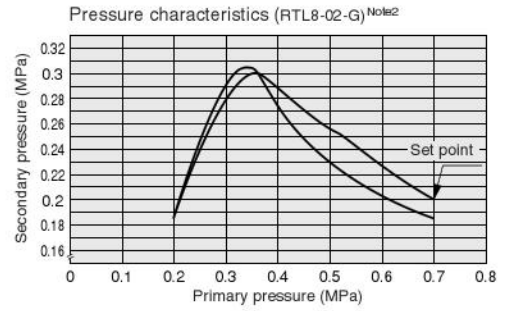
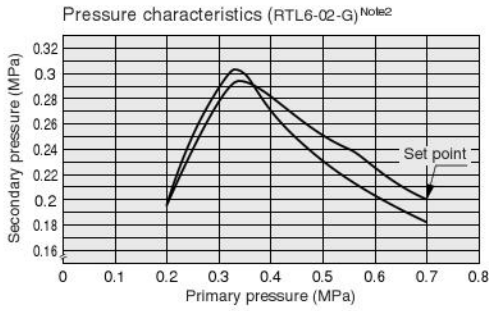
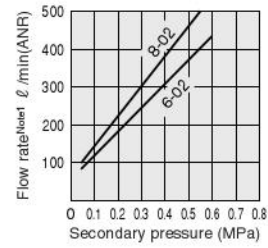
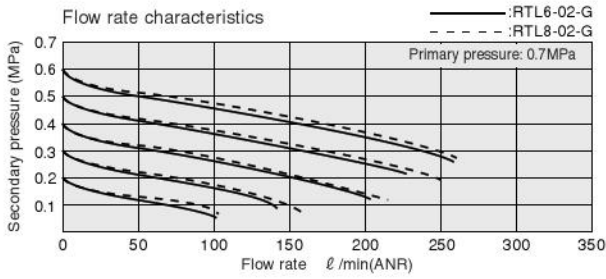

Notes: 1. Flow rate comes from secondary to primary pressure flow.
2. Primary pressure changes from 0.7MPa to 0.2MPa to 0.7MPa.

1MPa = 145psi. 1 ℓ/min = 0.0353ft³/min.

REGULATORS WITH QUICK FITTINGS

NCU Specification

- For specifications, see p.457.
- The dimensions, inner construction, major parts and materials for the **NCU** specification shown below are the same as the standard type. See inner construction, major parts and materials on p.457 and dimensions on p.458~459. The sealant is not applied to the R taper thread portion of the **NCU** specification fittings.

Caution: For delivery, consult us.

NCU Specification

● Order Codes

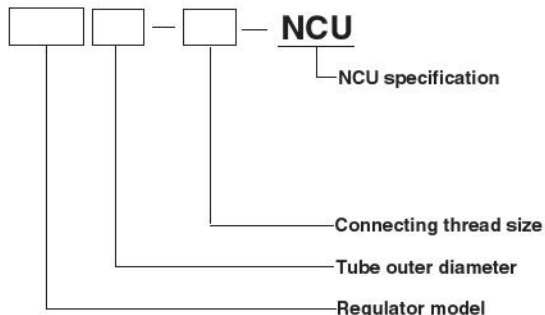

※For the fitting models, the tube size and thread combinations, see the table below. Columns showing the “←” symbol indicate that standard products can be used as the NCU specification. In these cases, place orders for the standard products.

● Model Table (NCU Specification)

Type	Tube outer diameter	Thread	Standard type model (reference)	NCU specification model
Straight RTS	4	M5×0.8	RTS4-M5	←
		R1/8	RTS4-01	RTS4-01-NCU
	6	M5×0.8	RTS6-M5	←
		R1/8	RTS6-01	RTS6-01-NCU
	8	R1/8	RTS8-01	RTS8-01-NCU
		R1/4	RTS8-02	RTS8-02-NCU
Elbow RTL	4	M5×0.8	RTL4-M5	←
		R1/8	RTL4-01	RTL4-01-NCU
	6	M5×0.8	RTL6-M5	←
		R1/8	RTL6-01	RTL6-01-NCU
	8	R1/4	RTL6-02	RTL6-02-NCU
		R1/8	RTL8-01	RTL8-01-NCU
	8	R1/4	RTL8-02	RTL8-02-NCU

Safety Precautions (Regulators with Quick Fittings)

The following is a safety precaution to Regulators with Quick Fittings. For other safety precautions, be sure to read the precautions on p.49.

Warning

- Do not force the product to rotate or swing even if the plastic body is rotatable. Such application could cause damage or leakage in the body.
- Do not use in situations where the secondary pressure fluctuation is so large that pressure exceeds the set value. The valve was not designed to be used as a relief valve, and such use could result in damage to equipment or in defective operation. In such cases, install a safety device for use.
- Do not use a mechanical tool to tighten the lock nut; instead, manually tighten the lock nut firmly in place. Using a mechanical tool to tighten could result in damage to the lock nut or the body. Also, if the lock nut is not firmly tightened, it could become loose, causing the initial setting to shift the position.

Handling Instructions and Precautions

● Mounting

Precautions for mounting the body

1. To mount the body, use a suitable tool to tighten it to the outer hexagonal sections of the body.
2. When tightening body thread, tighten to the recommended tightening torque shown in the table below. Tightening to more than the recommended torque could result in broken thread sections or air leaks due to deformed gaskets. Tightening to less than the recommended torque could lead to loose body thread or air leaks.

Recommended tightening torque

Thread type	Thread	Tightening torque
Metric thread	M5×0.8	1.5~1.9N·m [1.11~1.40ft·lbf]
Taper pipe thread	R1/8	7~9N·m [5.2~6.6ft·lbf]
	R1/4	12~14N·m [8.9~10.3ft·lbf]

Precautions for disconnecting the body

1. To disconnect the body, use a suitable tool to loosen it from the outer hexagonal section of the body.
2. Clean off the sealant coating on the thread of the removed mating part. The coated sealant could enter other relating parts, and cause breakdowns.

Method for tightening body thread

1. Tightening body thread

For tightening body thread, use a wrench on outer hexagonal section.

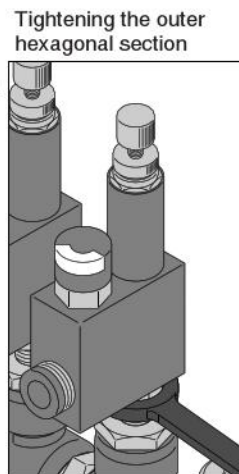

● Tube connection and disconnection

Precautions for connecting the tube

1. Check that the cut section of the tube has been cut at straight angle, that the outer surface of the tube is not scratched, and that the tube has not become oval shaped.
2. When connecting a tube, failure to insert the tube all the way to the end could result in air leaks.

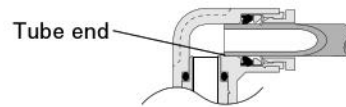

3. After connection, pull the tube to check that it will not disconnect.

Precautions for disconnecting the tube

1. Before disconnecting a tube, check that the pressure inside the tube is down to zero.
2. Push the release ring evenly all the way to the end, and then pull the tube out. An insufficient push could make it impossible to pull the tube out, or could scratch the tube, leaving scratched tube material inside the fitting.

Tube connection and disconnection method

1. Tube connection

The Regulator with Quick Fittings is equipped with a lock claw that holds the tube in place when it has been pushed all the way to the end, and with an elastic sleeve for sealing the tube periphery.

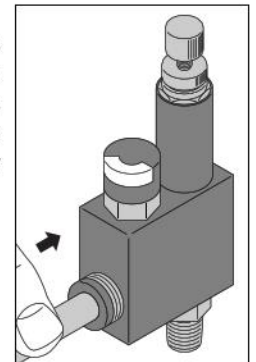

2. Tube disconnection

To disconnect the tube, first push on the release ring, releasing the lock claw, and then pull the tube out.

Always stop the air supply before removing the tube.

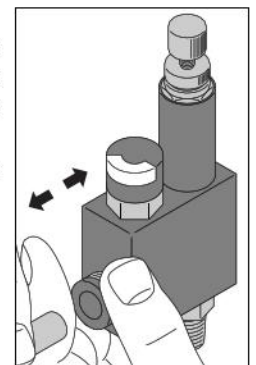

Handling Instructions and Precautions

For cases where tight or cramped piping spaces hinder tube removal operations, a special tool is available. Consult us for details.

Special tool for tube removal

For ϕ 3 [0.118in.], ϕ 4 [0.157in.] and ϕ 6 [0.236in.] tubes
Order code : **UJ-1**



For ϕ 6 [0.236in.], ϕ 8 [0.315in.],
 ϕ 10 [0.394in.] and ϕ 12 [0.472in.] tubes
Order code : **UJ-2**



● Usable tubes

Either nylon or urethane tubes can be used. The tube outer diameter accuracy should be, for nylon tubes, within $\pm 0.1\text{mm}$ [$\pm 0.004\text{in.}$] of the nominal dimensions, and for urethane tubes, within $\pm 0.15\text{mm}$ [$\pm 0.006\text{in.}$] of the nominal dimensions, while the ovalness (difference between long diameter and short diameter) should be within 0.2mm [0.008in.].

- Cautions:**
1. Use tubes with no visible scratches on the outer surface. If a scratch is made during repeated use, cut off the scratched portion.
 2. Do not bend or twist the tube too much near the connection to the fitting. It could result in air leaks. The minimum bending radius for nylon tubes is as shown in the table below.

mm [in.]	
Tube size	Minimum bending radius
ϕ 4 [0.157]	20 [0.8]
ϕ 6 [0.236]	30 [1.2]
ϕ 8 [0.315]	50 [2.0]

● Pressure gauge's mounting direction setting (for units with pressure gauge)

The gauge part can be rotated and set in the desired direction. To rotate the gauge part, always use a wrench, etc., on the hexagonal section of the pressure gauge cover. Rotating the cover by hand will rotate the pressure gauge's cover only, and could cause the needle to shift the position.

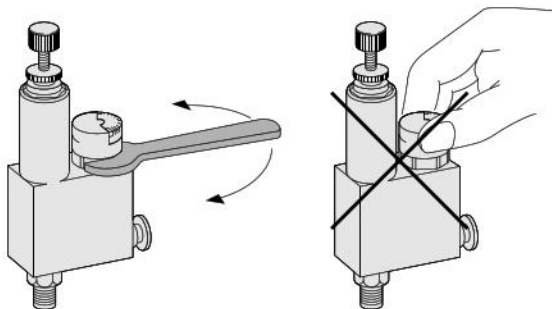

● Regulating pressure

1. When increasing pressure
From the fully open position, turning the regulator's pressure regulating knob in the clockwise direction raises the pressure. When the desired pressure is attained, be sure to tighten the lock nut to ensure that the pressure setting does not shift the position.

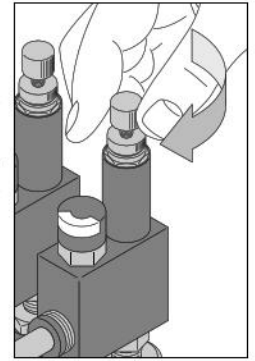

2. When reducing pressure
If the regulator's pressure regulating knob has been turned too far (the pressure has risen too high), turning it in the counterclockwise direction lowers the pressure. When the desired pressure is attained, be sure to tighten the lock nut to ensure that the pressure setting does not shift the position.

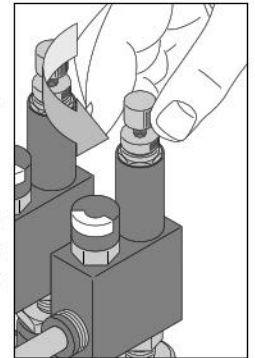

- Cautions:**
1. To set the pressure, turn the knob in the pressure increasing direction (clockwise rotation). The pressure reducing direction (counterclockwise rotation) cannot be used to obtain accurate settings.
 2. The gauge accuracy of the regulator with pressure gauge is $\pm 5\%$ FS (full-scale). For applications requiring finer accuracy, check the pressure using a gauge of suitable precision.