



Presenting our CAD
drawing data catalog



KOGANEI

ACTUATORS GENERAL CATALOG

ROTARY ACTUATORS VANE TYPE **RAK SERIES** INDEX

Domestic sales only.

Basic Types and Configurations	959
Specifications List	961
Inner Construction, Major Parts and Materials	964
Order Code	965
Dimensions	967

Sensor Switches	970
-----------------	-----

Shock Absorber Units	
Specifications	972
Dimensions of Shock Absorber Unit Levers	973

Parts Composition, and Assembly Methods	975
Handling Instructions, and Precautions	977

Discontinued

Medium to large series ranges brings easy application and easy selection.
Rotary actuator vane type demonstrates superior performance even at low pressure and low speeds.

RAK Series

■ **The medium and large sized rotary actuators come in single vane and double vane types.**

Achieves an effective high torque of 470N·cm~20152N·cm, with a line-up of three swing angles, 90°, 180°, and 270°. Moreover, sensor switches, shock absorbers, and other sub-units enable diversified equipment design through easy application and easy selection.

■ **Assures stable operation and high durability.**
 A highly rigid vane shaft and damper mechanism is built in. Moreover, the superior sealing mechanism demonstrates durability and achieves low friction with low leakage. And mounting a shock absorber unit makes it possible to drive even larger loads.

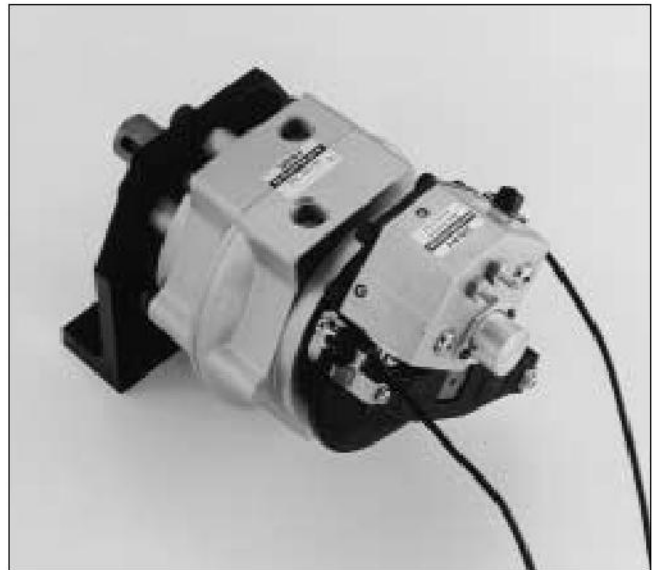

Basic Type and Configurations

Rotary actuator, single vane type RAK Series	Rotary actuator, double vane type RAKD Series	● With sensor switch unit
RAK50 Nominal torque 470N·cm RAK150 Nominal torque 1470N·cm RAK300 Nominal torque 2794N·cm RAK800 Nominal torque 10032N·cm	RAKD50 Nominal torque 1019N·cm RAKD150 Nominal torque 3432N·cm RAKD300 Nominal torque 6668N·cm RAKD800 Nominal torque 20152N·cm	

Relationship between Swing Angle and Key Groove Location (Starting Point of Swing 45°)

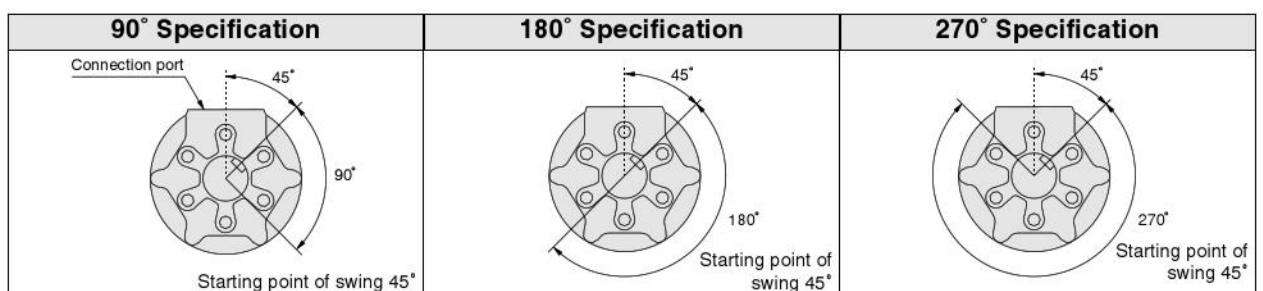

The RAK series responds to system design with flexible applications.

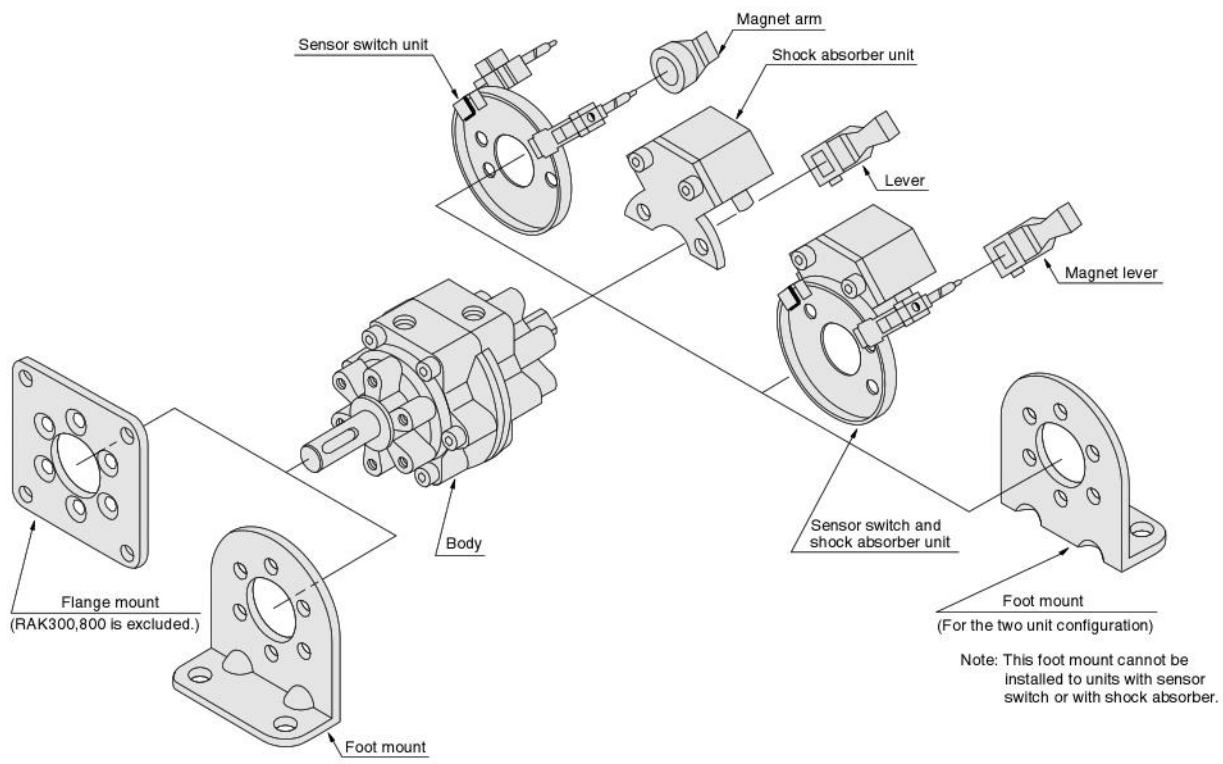

Mounting Type

Discontinued

■ Nose mount (direct front mounting)



■ Foot mount (use foot mounting brackets)



■ Flange mount (use flange mounting brackets)



ROTARY ACTUATORS

Specifications List



Specifications

● Single vane type

Item	Basic model	RAK50	RAK150	RAK300	RAK800
Operating type		Double acting single vane type			
Effective torque ^{Nkt01}	N·cm {kgf·cm}	470 {48}	1470 {150}	2794 {285}	10032 {1023}
Swing angle (Tolerance $\pm\frac{3}{0}$)		90° · 180° · 270°			
Media		Air			
Port size		Rc1/8	Rc1/4	Rc3/8	Rc1/2
Operating pressure range	MPa {kgf/cm ² }	0.2~1 {2~10.2}			
Proof pressure	MPa {kgf/cm ² }	1.5 {15.3}			
Operating temperature range (Ambient atmosphere or media)	°C	5~60			
Inner volume ^{Nkt02}	cm ³	51 {61}	146 {179}	244 {352}	754 {1036}
Allowable energy	mJ {kgf·cm}	49 {0.5}	225.4 {2.3}	1078 {11}	3920 {40}
Allowable radial load	N {kgf}	588 {60}	1176 {120}	1960 {200}	4900 {500}
Allowable thrust load ^{Nkt03}	N {kgf}	44.1 {4.5}	88.2 {9}	147 {15}	490 {50}
Lubrication		Not required			
Sensor switches ^{Nkt04}		Adaptive sensor switch : ZG530□, ZG553□, CS3M□, CS4M□, CS5M□			

● Double vane type

Item	Basic model	RAKD50	RAKD150	RAKD300	RAKD800
Operating type		Double acting double vane type			
Effective torque ^{Nkt01}	N·cm {kgf·cm}	1019 {104}	3432 {350}	6668 {680}	20152 {2055}
Swing angle (Tolerance $\pm\frac{3}{0}$)		90°			
Media		Air			
Port size		Rc1/8	Rc1/4	Rc3/8	Rc1/2
Operating pressure range	MPa {kgf/cm ² }	0.2~1 {2~10.2}			
Proof pressure	MPa {kgf/cm ² }	1.5 {15.3}			
Operating temperature range (Ambient atmosphere or media)	°C	5~60			
Inner volume ^{Nkt02}	cm ³	42	127	244	754
Allowable energy	mJ {kgf·cm}	49 {0.5}	225.4 {2.3}	1078 {11}	3920 {40}
Allowable radial load	N {kgf}	588 {60}	1176 {120}	1960 {200}	4900 {500}
Allowable thrust load ^{Nkt03}	N {kgf}	44.1 {4.5}	88.2 {9}	147 {15}	490 {50}
Lubrication		Not required			
Sensor switches ^{Nkt04}		Adaptive sensor switch : ZG530□, ZG553□, CS3M□, CS4M□, CS5M□			

Notes 1: Value when the air pressure is 0.49 MPa {5kgf/cm²}. 2: Value when the swing angle is 90°. The value in parentheses () is the value of the swing angle at maximum use. 3: Numerical values are reference values, not guaranteed values. For details, see page 977. 4: For details, see page 1096.

Mass

Basic type and swing angle		Body mass		Additional mass			
		Mounting type		Mounting bracket		Sensor switch unit	Sensor switch and shock absorber unit
		Nose mount		Foot mount	Flange mount		
RAK50	90°	0.82		0.254	0.186	0.08	0.375
	180°	0.79					0.375
	270°	0.73					0.35
RAK150	90°	2.0		1.1	0.475	0.127	0.68
	180°	1.9					0.675
	270°	1.7					0.64
RAK300	90°	3.7		1.93	—	0.205	1.285
	180°	3.7					1.295
	270°	3.7					1.195
RAK800	90°	12.7		4.47	—	0.292	2.975
	180°	12.2					2.985
	270°	11.2					2.735
RAKD50	90°	0.82		0.254	0.186	0.08	0.375
RAKD150	90°	2.0		1.1	0.475	0.127	0.68
RAKD300	90°	4.3		1.93	—	0.205	1.285
RAKD800	90°	12.7		4.47	—	0.292	2.975

Output Characteristics

● RAK50

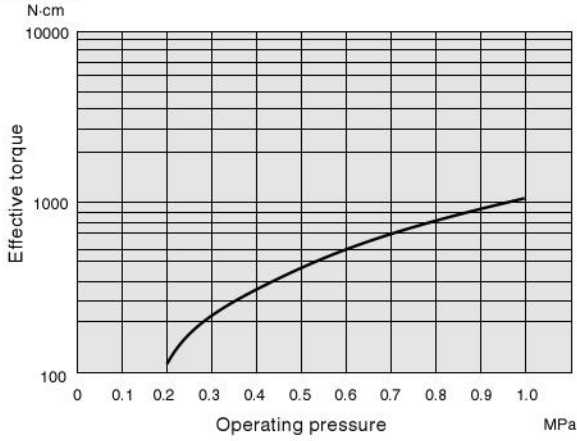

● RAKD50

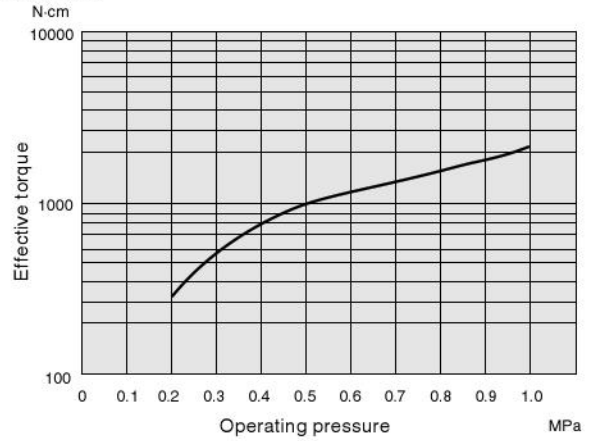

● RAK150

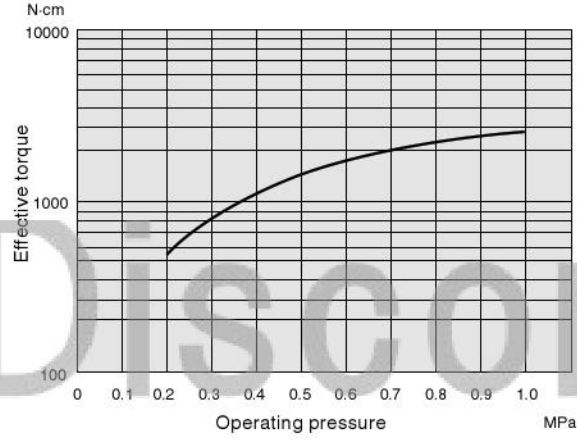

● RAKD150

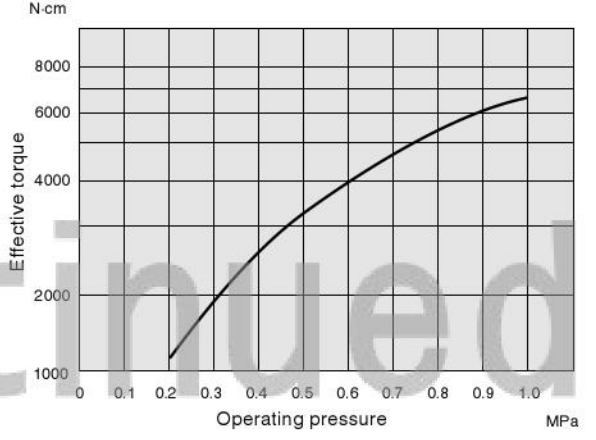

● RAK300

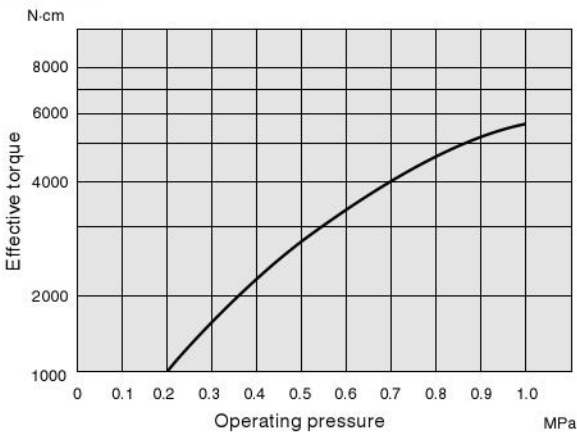

● RAKD300

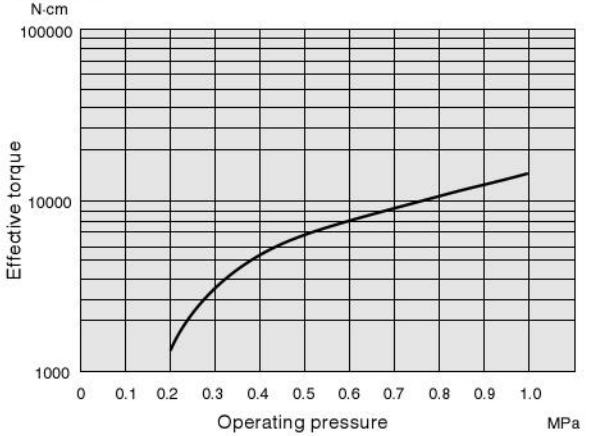

● RAK800

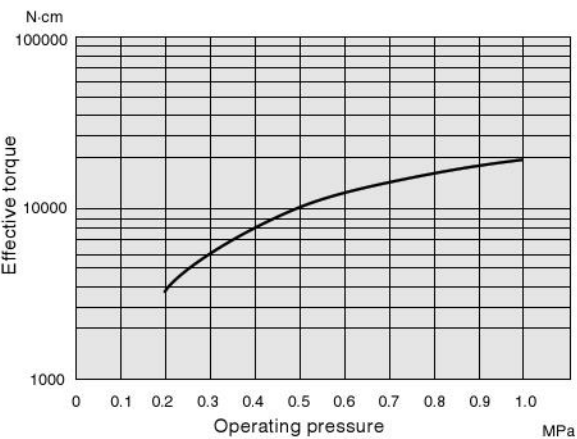

● RAKD800

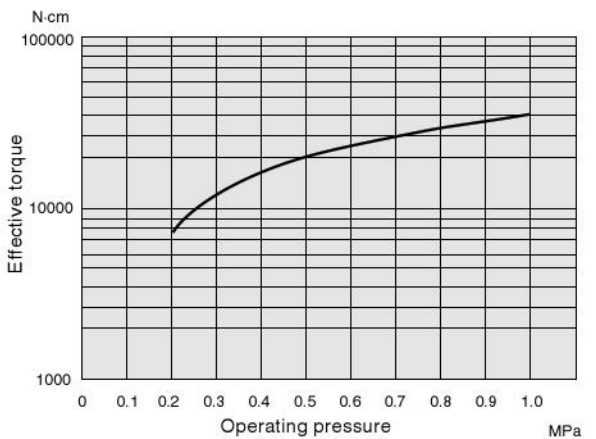

Air Consumption

SI unit conversion/1MPa \approx 10.2kgf/cm²

●RAK50

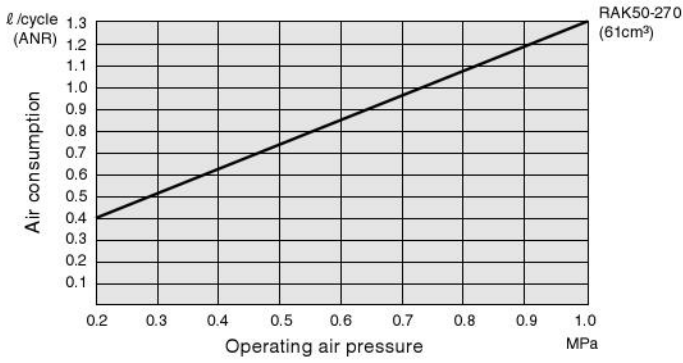

●RAKD50

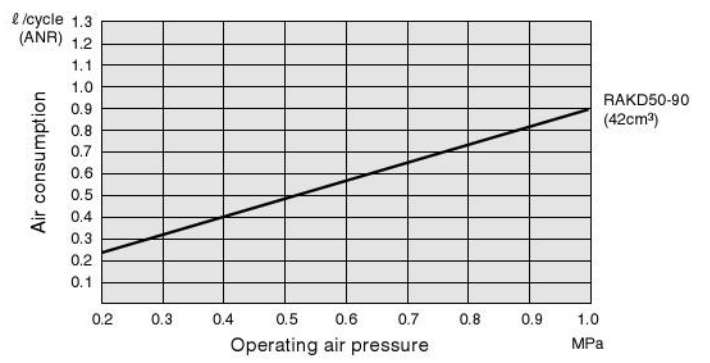

●RAK150

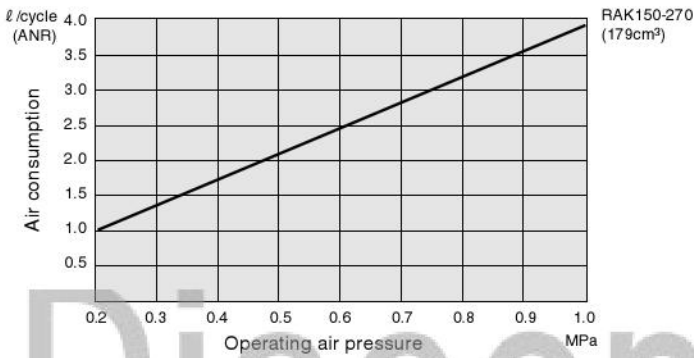

●RAKD150

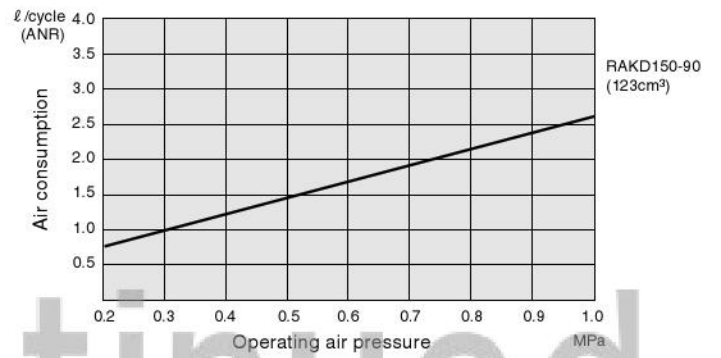

●RAK300

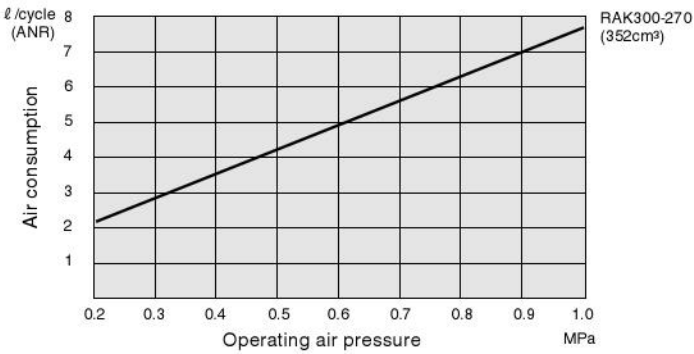

●RAKD300

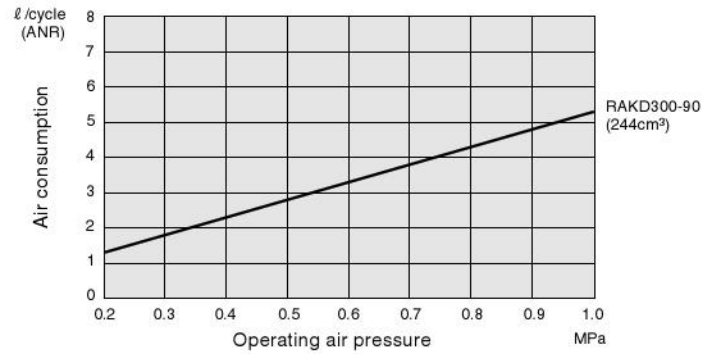

●RAK800

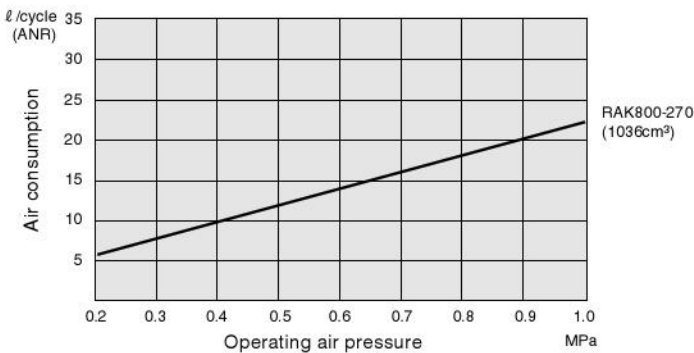

●RAKD800

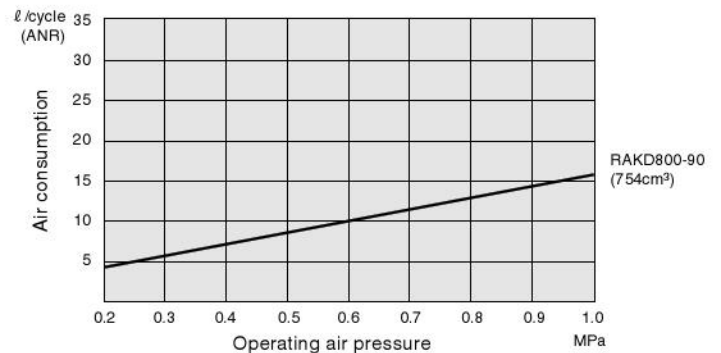

Inner Construction, Major Parts and Materials

●RAK single vane type

RAK50·150·300

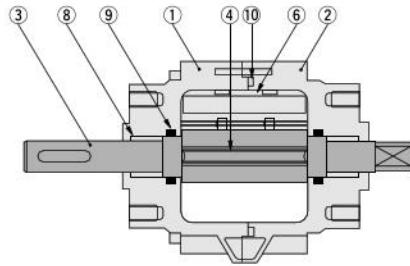
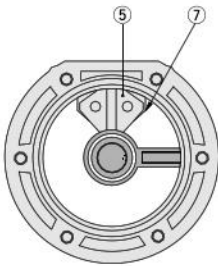

No.	Parts	Materials
①	Main body A	ADC (For 300, AC)
②	Main body B	ADC (For 300, AC)
③	Vane shaft	SCM
④	Vane seal	Synthetic rubber (NBR)
⑤	Shoe	ZDC
⑥	Shoe seal	Synthetic rubber (NBR)
⑦	Damper	Urethane
⑧	Bearing	Oil-permeated sintered alloy
⑨	O-ring	Synthetic rubber (NBR)
⑩	O-ring	Synthetic rubber (NBR)

RAK800

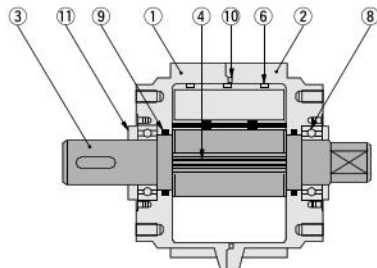
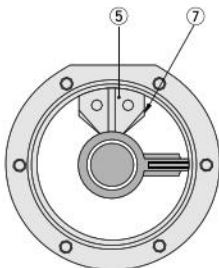

No.	Parts	Materials
①	Main body A	AC
②	Main body B	AC
③	Vane shaft	SCM
④	Vane seal	Synthetic rubber (NBR)
⑤	Shoe	ZDC
⑥	Shoe seal	Synthetic rubber (NBR)
⑦	Damper	Urethane
⑧	Bearing	Hard steel
⑨	O-ring	Synthetic rubber (NBR)
⑩	O-ring	Synthetic rubber (NBR)
⑪	Cover plate	Hard steel

●RAKD double vane type

RAKD50·150·300

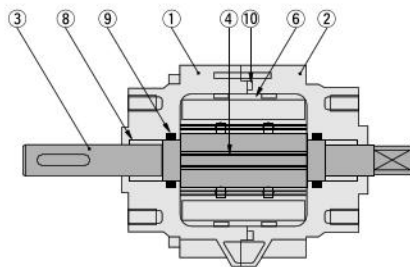
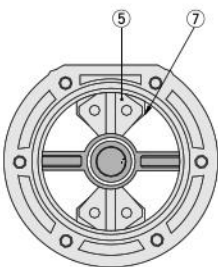

No.	Parts	Materials
①	Main body A	ADC (For 300, AC)
②	Main body B	ADC (For 300, AC)
③	Vane shaft	SCM
④	Vane seal	Synthetic rubber (NBR)
⑤	Shoe	ZDC
⑥	Shoe seal	Synthetic rubber (NBR)
⑦	Damper	Urethane
⑧	Bearing	Oil-permeated sintered alloy
⑨	O-ring	Synthetic rubber (NBR)
⑩	O-ring	Synthetic rubber (NBR)

RAKD800

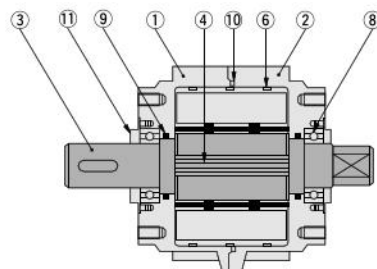
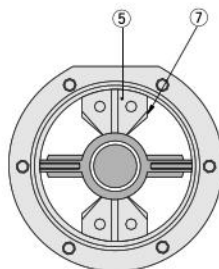

No.	Parts	Materials
①	Main body A	AC
②	Main body B	AC
③	Vane shaft	SCM
④	Vane seal	Synthetic rubber (NBR)
⑤	Shoe	ZDC
⑥	Shoe seal	Synthetic rubber (NBR)
⑦	Damper	Urethane
⑧	Bearing	Hard steel
⑨	O-ring	Synthetic rubber (NBR)
⑩	O-ring	Synthetic rubber (NBR)
⑪	Cover plate	Hard steel

Discontinued

Order Code

Type of vane	Swing angle	Mounting type	Number of mounting bracket	Type of sub-unit	Sensor switch (Model, lead wire length, number)				
Single vane type Blank	90° ● Starting point of swing : 45°	Nose mount Blank	Without mounting bracket Blank	Without sub-unit Blank	Without sensor switch Blank				
Double vane type D	180° ● Starting point of swing : 45°	Foot mount -1A	With one mounting bracket 1	With shock absorber unit -UK	ZG530 -ZG530 ● Solid state type with indicator lamp 2-lead wire DC10~28V				
	270° ● Starting point of swing : 45°	Flange mount -3A	With two mounting brackets 2	With sensor switch unit -US	ZG553 -ZG553 ● Solid state type with indicator lamp 3-lead wire DC4.5~28V				
	● Double vane type available for 90° only.	● For the order code for mounting brackets only, see page 966.	● For the foot mount only.	● For the order code for sub-units only, see page 966.	CS3M -CS3M ● Reed switch type with indicator lamp DC10~30V AC85~230V				
				With sensor switch and shock absorber unit -USK	CS4M -CS4M ● Reed switch type with indicator lamp DC10~30V AC85~115V				
					CS5M -CS5M ● Reed switch type without indicator lamp DC3~30V AC85~115V				
Basic type	Type								
RAK	D	50 150 300 800	-90 -180 -270	-1A -3A	1 2	-UK -US -USK	-ZG530 -ZG553 -CS3M -CS4M -CS5M	A B	1 2

- Lead wire length
A : 1000mm
B : 3000mm
- Number
1 : With one sensor switch
2 : With two sensor switches

Caution: All mounting brackets, sub-units, and sensor switches are included at time of delivery. For the sub-unit mounting type, see pages 975-976 for mounting. Note that a "Handling Manual" containing an explanation of the mounting type is included with the sub-unit.

● The code -US, -USK come with two sensor brackets and sensor holders.

Order Code for Additional Parts (Sold Separately)

● Order code for shock absorber units (With lever)

UK-RAK -

Type	Swing angle
50	90 : 90°
150	180 : 180°
300	270 : 270°
800	

● Order code for shock absorbers only (without lever)

UKN-RAK

Type
50
150
300
800

● Order code for shock absorber unit levers only

UKT-RAK -

Type	Swing angle
50	90 : 90°
150	180 : 180°
300	270 : 270°
800	

● Order code for sensor units

US-RAK

Type
50
150
300
800

Remarks 1: With two sensor brackets and sensor holders
2: Place a separate order for the sensor switches.

● Order code for base brackets only

USB-RAK

Type
50
150
300
800

(RAK800 comes with sensor bracket)

● Order code for magnet arms only

USA-RAK

Type
50
150
300
800

● Order code for sensor switch brackets only

G5-RAK

Type
50
150
300

Remark : With sensor holder

● Order code for sensor switches and shock absorber units (with lever)

USK-RAK -

Type	Swing angle
50	90 : 90°
150	180 : 180°
300	270 : 270°
800	

Remarks 1: With two sensor brackets and sensor holders
2: Place a separate order for the sensor switches.

● Order code for magnet levers only

USA-RAK - - USK

Type	Swing angle
50	90 : 90°
150	180 : 180°
300	270 : 270°
800	

● Order code for base brackets only

USB-RAK

Type
50
150
300

Remark : Not available in RAK800.

● Order code for sensor switch brackets only

G5-RAK -USK

Type
50
150
300

Remark : With sensor holder

● Order code for mounting brackets only

- RAK

Types of mounting bracket	Type
1A : Foot mounting type	50
3A : Flange mounting type	150
(For RAK50, 150 only)	300
	800

Discontinued

**Nose mount
(Direct front mounting)**

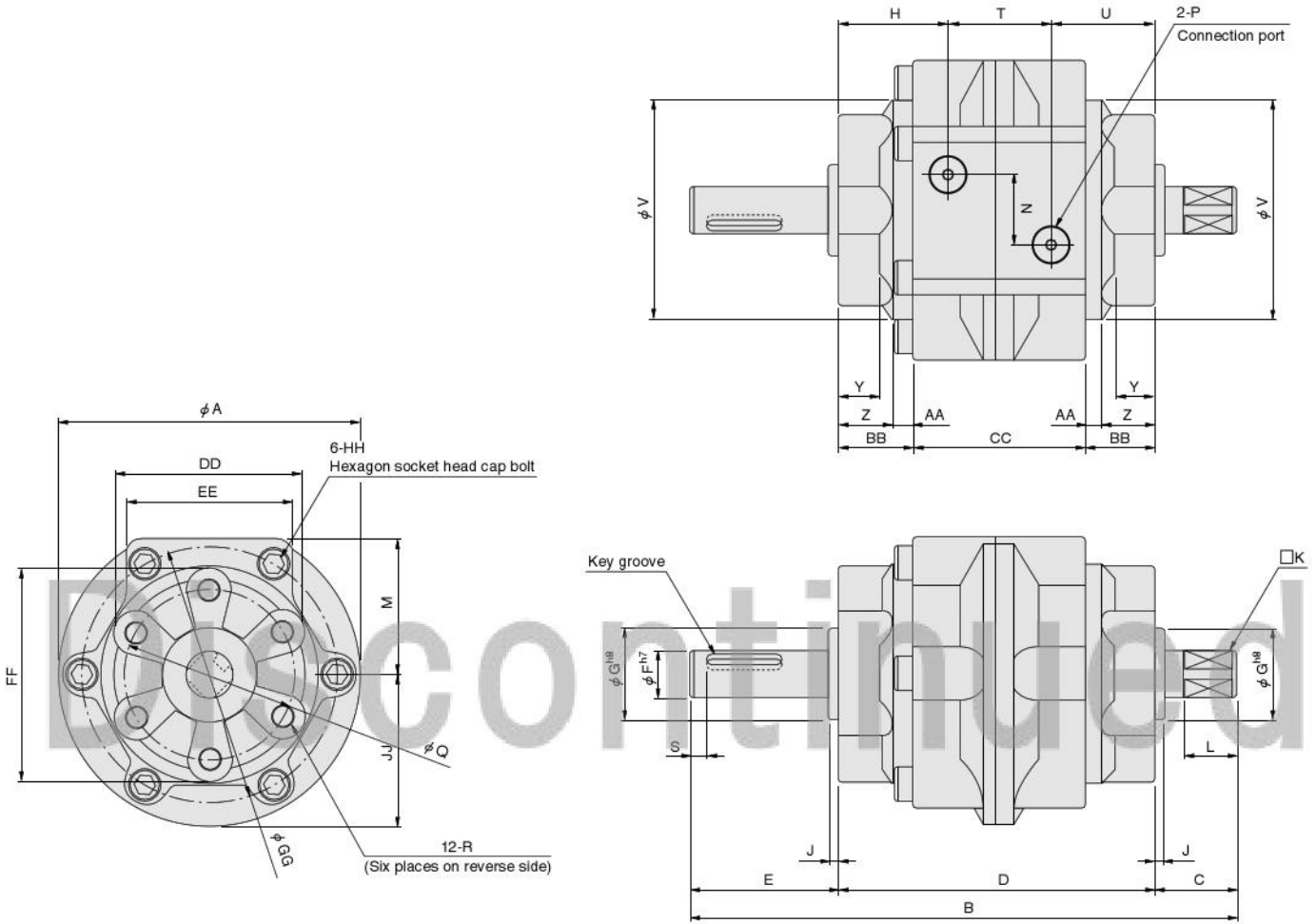

Model	Code	A	B	C	D	E	F	G	H	J	K	L	M	N	P	Q	R	S	T
RAK50		79	145	19.5	86	39.5	12	25	29	2.5	10	13	36	16	Rc1/8	45	M6X1 Depth9	5	28
RAK150		110	180	23.5	103	53.5	17	30	34.5	3	13	16	51	24	Rc1/4	70	M8X1.25 Depth12	5	34
RAK300		141.5	220	30	125	65	25	45	41.5	3.5	19	22	66	32	Rc3/8	80	M10X1.5 Depth15	5	42
RAK800		196	285	44.5	171	69.5	40	70	53.5	4.5	32	35	90	44	Rc1/2	120	M12X1.75 Depth18	10	64

Model	Code	U	V	Y	Z	AA	BB	CC	DD	EE	FF	GG	HH	JJ	Key groove	WidthXDepthXLength
RAK50		29	58	11	14	6	20	46	51	44	57	68	M5X30 ℓ	39.5	4 ⁰ _{-0.03} X2.5 ^{+0.1} ₀ X20	
RAK150		34.5	85.2	10.5	15.5	8	23.5	56	75	61	85	97	M6X35 ℓ	55	5 ⁰ _{-0.03} X3 ^{+0.1} ₀ X36	
RAK300		41.5	110	13	17.5	10	27.5	70	88.5	78	98.5	125	M8X45 ℓ	70.5	7 ⁰ _{-0.036} X4 ^{+0.2} ₀ X40	
RAK800		53.5	152	14.5	21.1	11.4	32.5	106	130	110	145	173	M12X70 ℓ	98	12 ⁰ _{-0.043} X5 ^{+0.2} ₀ X40	

**Foot mount -1A
(Foot mounting brackets)**

RAK150·300·800

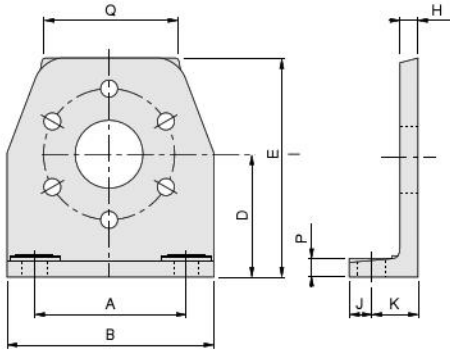

RAK50

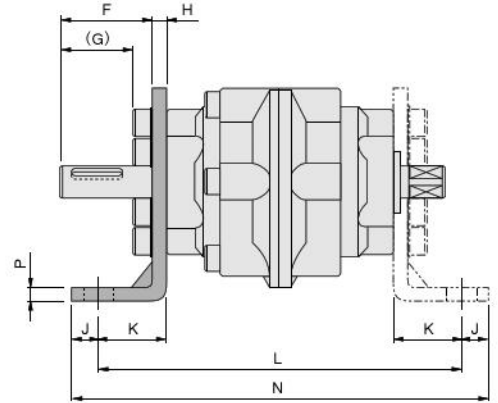
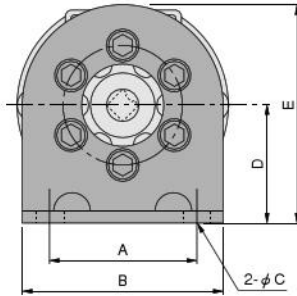

Model	Code	A	B	C	D	E	F	G	H	J	K	L	N	P	Q
RAK50		55	75	11	45	82.5	35	27.5	4.5	10	25	136	156	4.5	—
RAK150		80	110	13	65	115	43.5	33.5	10	12	28	159	183	10.5	70
RAK300		100	140	15	80	135	53	40.5	12	13	32	189	215	12	80
RAK800		140	200	15	110	185	54.5	39.5	15	15	35	241	271	15	120

Remarks 1: Foot mounting brackets can be mounted every 60° of rotation.
2: The square shaft side is used only with two foot mounting brackets.

**Flange mount-3A
(Flange mounting brackets)**

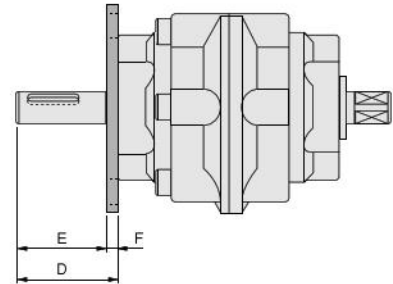
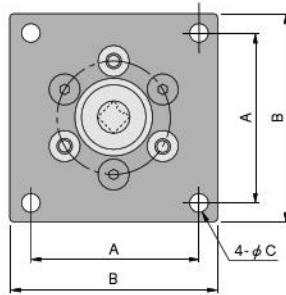

Model	Code	A	B	C	D	E	F
RAK50		64	80	7	39.5	35	4.5
RAK150		88	110	9	53.5	47.5	6

Remark : Flange mounting brackets can be mounted every 60° of rotation.

Discontinued

With shock absorber unit-UK

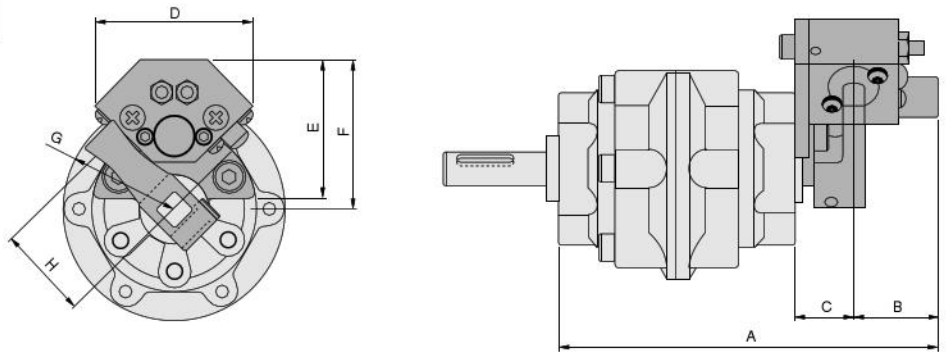

Model	Code	A	B	C	D	E	F	G	H
RAK50		136.5	30	20.5	56	50	54	R38	34
RAK150		159.5	34	22.5	80	62	71.5	R51	46
RAK300		187.5	37	25.5	95	87	96	R68	62
RAK800		244	42	31	130	118	135	R78	90

With sensor switch unit-US

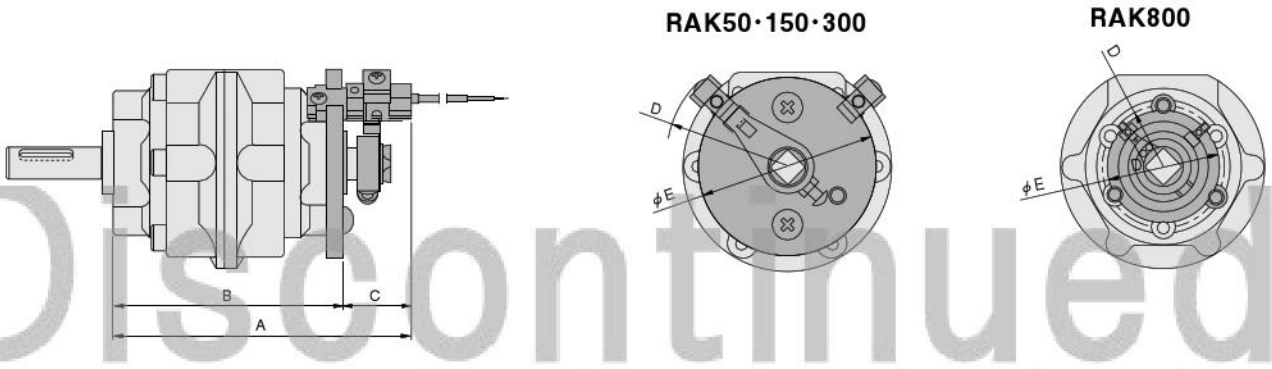

Model	Code	A	B	C	D	E
RAK50		110.7	87.2	23.5	R47	69
RAK150		127.7	104.2	23.5	R61	97
RAK300		159.7	126.2	33.5	R69	113
RAK800		213.2	174.2	39.0	R60	108

With sensor switch and shock absorber unit-USK

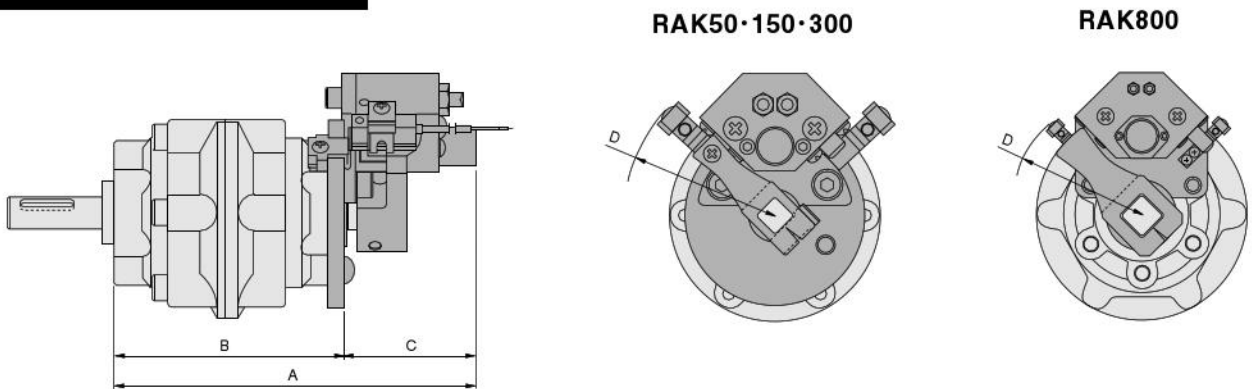

Model	Code	A	B	C	D
RAK50		137.7	87.2	50.5	R58.2
RAK150		160.7	104.2	56.5	R72.2
RAK300		188.7	126.2	62.5	R88.2
RAK800		244	174.2	69.8	R118.5

SENSOR SWITCHES

Solid State Type · Reed Switch Type



Order code for sensor switches only

				Sensor switch model	Lead wire length
Solid state type	2-lead wire	With indicator lamp	DC10~28V	ZG530	A B
Solid state type	3-lead wire	With indicator lamp	DC4.5~28V	ZG553	
Reed switch type	2-lead wire	With indicator lamp	DC10~30V AC85~230V	CS3M	A B
Reed switch type	2-lead wire	With indicator lamp	DC10~28V AC85~115V	CS4M	
Reed switch type	2-lead wire	Without indicator lamp	DC 3~30V AC85~115V	CS5M	

● For details of sensor switches, see page 1096.

● A : 1000mm
B : 3000mm

Sensor Switch Operating Range · Response Differential · Maximum Sensing Location

● Operating range : ℓ

The switch turns ON when the vane shaft rotates in the \Rightarrow direction, and the magnet comes to position A. The operating range is movement in the A-B interval while the switch is ON.

● Response differential : C

When the magnet comes to position A to turn the switch ON, and then rotates in the opposite direction \Leftarrow , the switch remains ON until the magnet reaches position C. This A-C interval is the response differential.

Model		ZG530□, ZG553□		CS3M□, CS4M□, CS5M□	
		Operating range : ℓ	Response differential : C	Operating range : ℓ	Response differential : C
RAK50	Basic type	About 25°	About 1°	About 29°	About 4°
	With shock absorber	About 19°	About 1°	About 21°	About 3°
RAK150	Basic type	About 17°	About 1°	About 19°	About 3°
	With shock absorber	About 14°	About 1°	About 16°	About 2°
RAK300	Basic type	About 14°	About 1°	About 16°	About 2°
	With shock absorber	About 11°	About 1°	About 12°	About 2°
RAK800	Basic type	About 18°	About 1°	About 20°	About 3°
	With shock absorber	About 7°	About 1°	About 8°	About 1°

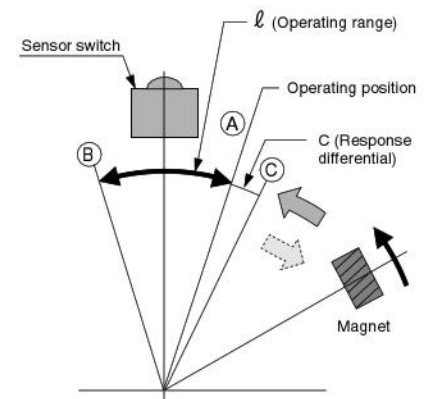

Moving and Adjusting Sensor Switch

Since the maximum sensing location for the sensor switches is different for each type, see the following instructions for movement and adjustment during mounting.

- When mounting the sensor switch, install the magnet arm and magnet lever as shown in the diagram below.

●When shock absorber unit is not included

Bring the magnet to position X.

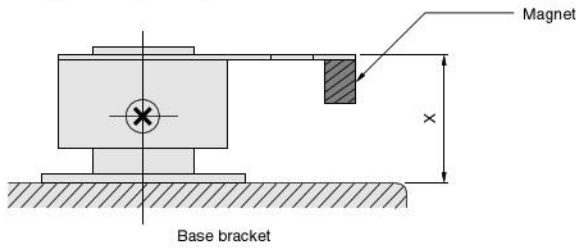

Model	X (mm)
RAK50	16.5
RAK150	16.5
RAK300	26.5
RAK800	30.0

●When shock absorber unit is included

Insert the magnet lever until it comes up against the base bracket side.

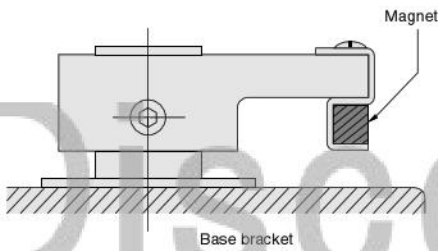

- When mounting a sensor switch on the sensor bracket, install according to the following instructions.

●RAK50·150

- Use a bracket to temporarily hold the sensor switch, and set the magnet directly underneath the sensor switch.
- Push the sensor switch against the deep end of the bracket, and confirm the point where it turns ON. After confirmation, fix the bracket in place.

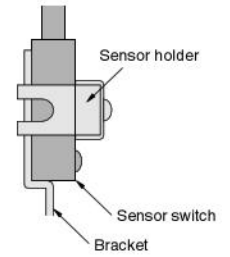

●RAK300·800

- Use a bracket to temporarily hold the sensor switch, and set the magnet directly underneath the sensor switch.
- Set the distance between the bracket end and the case end of the sensor switch (lead wire side) to the ℓ value shown in the diagram.

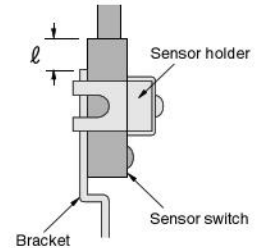

Model		ℓ (mm)
RAK50	Basic type	—
	With shock absorber	0
RAK150	Basic type	—
	With shock absorber	1.5
RAK300	Basic type	3.0
	With shock absorber	1
RAK800	Basic type	-2.0 ^{Note}
	With shock absorber	6.0

Note: ℓ minus sign on one value means that the sensor switch should be pulled back from the bracket end point.

- When mounting the sensor switch, adjust the bracket with a certain amount of bending until the gap between the sensor switch and the bracket is within the dimensions (1-2mm) shown in the diagram below.

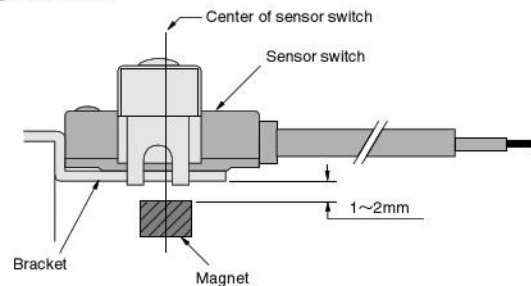

SHOCK ABSORBER UNITS



Specifications

Item	Basic model	UKN-RAK50	UKN-RAK150	UKN-RAK300	UKN-RAK800
Load range	kg·cm ² {kgf·cm·s ⁻² }	981 {1} or less	2942 {3} or less	5884 {6} or less	19613 {20} or less
Maximum energy absorption	mJ {kgf·cm}	2942 {30}	9807 {100}	19613 {200}	58840 {600}
Maximum impact angle velocity	Degrees/s	850	750	650	550
Maximum energy absorption per minute	mJ/min {kgf·cm/min}	19613 {200}	70608 {720}	137293 {1400}	353039 {3600}
Ambient temperature range	°C	5~50			
Absorption angle (One side)	Degrees	11	12	14	15
Mass	g	240	420	780	1620

Remarks 1: Energy capacity per minute = Absorbed energy × 2N [N : Operating frequency (cycles/min)]

2: When using with a shock absorber, set the rotary actuator pressure to 0.29MPa {3kgf/cm²} or higher.

Operating Principle

When the lever installed on the rotary actuator's vane shaft collides against the piston, collided energy is converted into pressure (hydraulic pressure) on the back side of the piston. This pressure energy turns into heat energy when it passes through gaps between the piston and the inner surface of the cylinder, and also through the adjusting needle, and is completely consumed by the time the piston stops at the stroke end. The piston in the opposite side remains at the original point by hydraulic pressure caused by spring force.

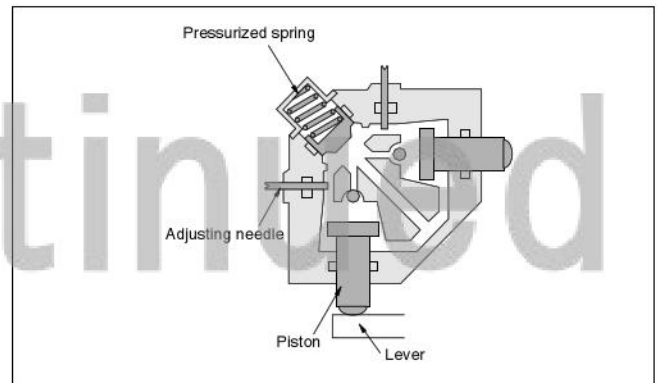

Dimensions of Shock Absorber (Unit mm)

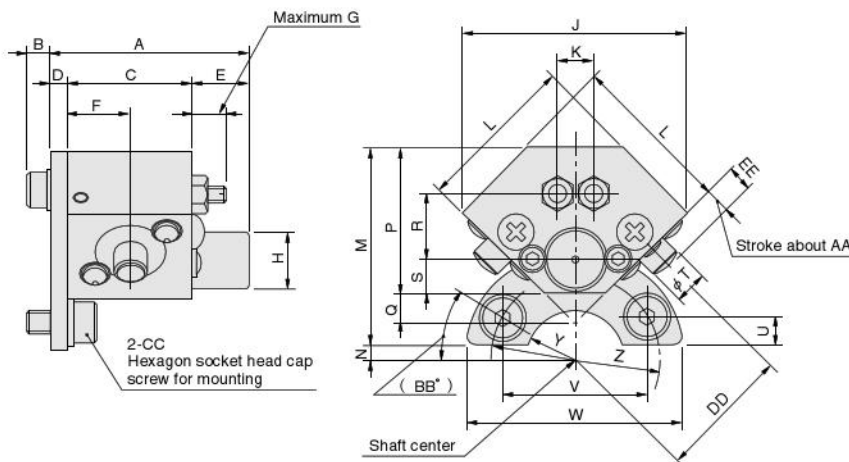

Model Code	A	B	C	D	E	F	G	H	J	K	L	M	N	P	Q	R	S	T	U	V	W	Y	Z	AA	BB	CC	DD	EE
UKN-50	50.5	6	32	4.5	14	16	8.5	14.4	56.6	9.9	40	50	4	37	7.1	17	9.2	8	7.2	39	56	R12.5	R45	6.5	30	M4×12 ℓ	34	8
UKN-150	56.5	7.2	36	4.5	16	18	8.5	18.4	70.7	11.3	50	62	9.5	49	8.4	25.5	11.4	10	8	60.6	80	R15	R70	10	30	M8×16 ℓ	46	12
UKN-300	62.5	7.2	42	4.5	16	21	12	22.5	91.9	12.7	65	87	8	61	14.2	33.2	14.1	12	12	69.2	95	R22.5	R80	15	30	M10×20 ℓ	62	18
UKN-800	73	7.2	50	6	17	25	12	32.5	127	14.2	90	118	17	82	24.7	46.7	20.6	16	13	103.9	130	R35	R120	24	30	M12×20 ℓ	90	27.5

Dimensions of Shock Absorber Unit Lever (Unit mm)

● For swing angle 90°

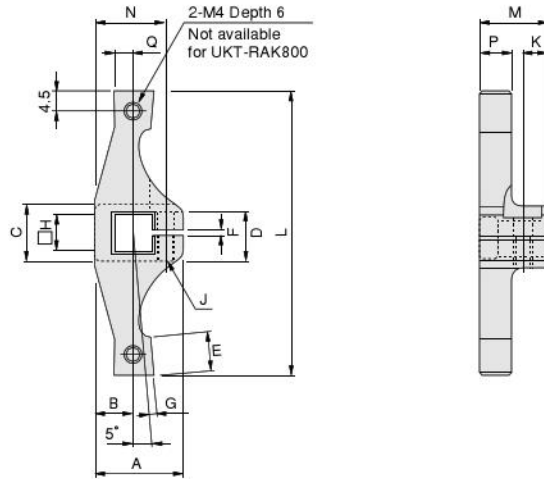

Model	Code	A	B	C	D	E	F	G	H	J	K	L	M	N	P	Q
UKT-RAK50-90		23	10	16	13.7	10	1.2	2.5	10	M5	7	76	18	18.5	8	5
UKT-RAK150-90		28	12	24	19.5	12	1.2	4	13	M6	7.5	102	20	23	10	5
UKT-RAK300-90		40	18	35	30.5	14	1.2	5.4	19	M8	9	136	23.5	33.5	12	9
UKT-RAK800-90		63	29	58	49	18	1.2	8	32	M10	14.5	196	29.5	55	16	14

● For swing angle 180°

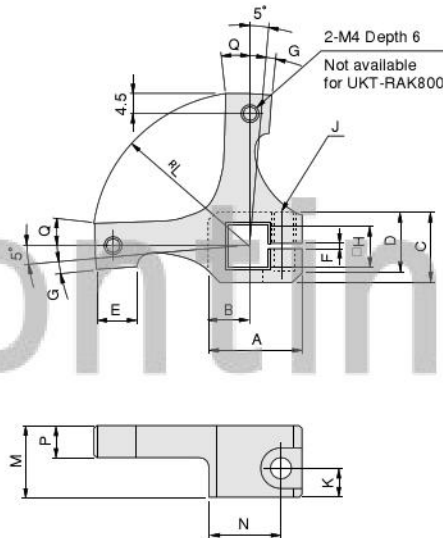

Model	Code	A	B	C	D	E	F	G	H	J	K	L	M	N	P	Q
UKT-RAK50-180		23	10	16	13.7	10	1.2	2.5	10	M5	7	38	18	18.5	8	5
UKT-RAK150-180		28	12	24	19.5	12	1.2	4	13	M6	9	51	20	23	10	5
UKT-RAK300-180		40	18	35	30.5	14	1.2	5.4	19	M8	11	68	23.5	33.5	12	9
UKT-RAK800-180		63	29	58	49	18	1.2	8	32	M10	14.5	98	29.5	55	16	14

● For swing angle 270°

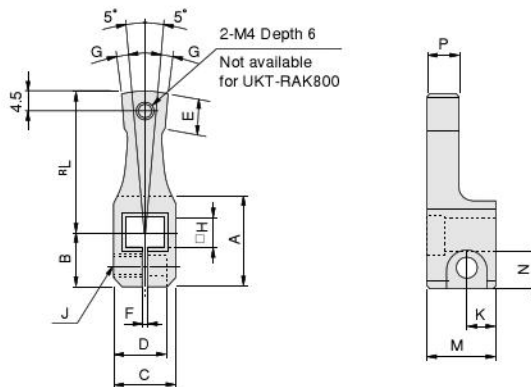

Model	Code	A	B	C	D	E	F	G	H	J	K	L	M	N	P
UKT-RAK50-270		23	13	16	13.7	10	1.2	2.6	10	M5	7	38	18	4.5	8
UKT-RAK150-270		28	16	24	19.5	12	1.2	4.1	13	M6	9	51	20	5	10
UKT-RAK300-270		40	22	35	30.5	14	1.2	5.5	19	M8	11	68	23.5	6.5	12
UKT-RAK800-270		63	34	58	49	18	1.2	8	32	M10	14.5	98	29.5	8	16

Dimensions of Key for RAK (Unit mm)

The **RAK** series is equipped with the following keys at time of delivery.

JIS B 1301 Parallel keys B×H×L Crossing S50C

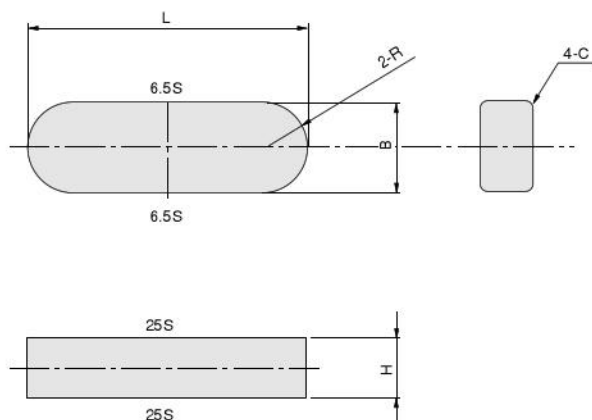

Model	Nominal key	B	H	L	C	R
RAK50 RAKD50	4×4×20	4 ⁰ _{-0.03}	4 ⁰ _{-0.03}	20 ⁰ _{-0.21}	0.16~0.25 (R0.16~0.25)	2
RAK150 RAKD150	5×5×36	5 ⁰ _{-0.03}	5 ⁰ _{-0.03}	36 ⁰ _{-0.25}	0.25~0.40 (R0.25~0.40)	2.5
RAK300 RAKD300	7×7×40	7 ⁰ _{-0.036}	7 ⁰ _{-0.036}	40 ⁰ _{-0.25}	0.25~0.40 (R0.25~0.40)	3.5
RAK800 RAKD800	12×8×40	12 ⁰ _{-0.043}	8 ⁰ _{-0.09}	40 ⁰ _{-0.25}	0.40~0.60 (R0.40~0.60)	6

Discontinued

Parts Composition and Assembly Methods

Sensor Switch Unit

● Subject models : RAK(D)50-150-300

- ① Mount the base bracket on the square shaft side of the rotary actuator by using two mounting screws.
- ② Attach the magnet arm by using a magnet arm fixing screw. At this time, confirm that the vane shaft of the rotary actuator is at the swing start position.
- ③ Mount sensor switch brackets on the swing start position and the opposite swing end position. (See the diagram on page 959 "Relationship between Swing Angle and Key Groove Location.")
- ④ For sensor switch mounting, moving, and adjusting, and for magnet arm mounting and adjusting, see "Moving and Adjusting Sensor Switch."

Note : In locations exposed to strong magnetic fields nearby, use a steel plate, etc., to serve as a magnetic shield.
In addition, do not bring strong magnetic objects (iron, etc.) close to the rotary actuator body and the sensor switch (within about 20mm).

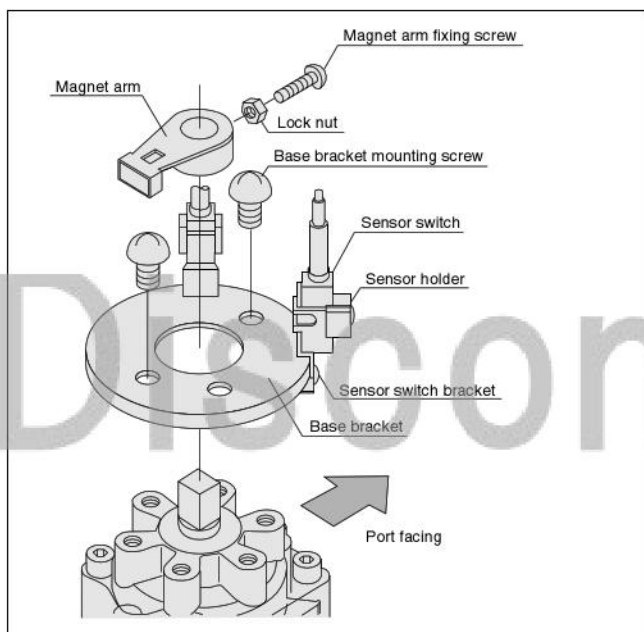

● Subject models : RAK(D)800

- ① Temporarily set two base brackets on the square shaft side of the rotary actuator by using three mounting bolts.
- ② Attach the magnet arm by using a magnet arm fixing screw. At this time, confirm that the vane shaft of the rotary actuator is at the swing start position.
- ③ Rotate and move the base brackets so that the sensor switch brackets come to the swing start position and the opposite swing end position. (See the diagram on page 959 "Relationship between Swing Angle and Key Groove Location.") Once the position has been determined, firmly mount with the three mounting bolts.
- ④ For sensor switch mounting, moving, and adjusting, and for magnet arm mounting and adjusting, see "Moving and Adjusting of Sensor Switches."

Note : In locations exposed to strong magnetic fields nearby, use a steel plate, etc., to serve as a magnetic shield.
In addition, do not bring strong magnetic objects (iron, etc.) close to the rotary actuator body and the sensor switch (within about 20mm).

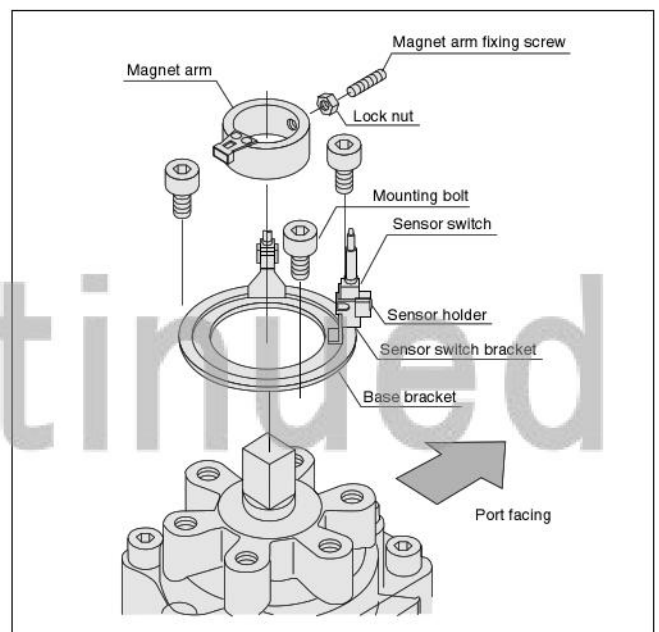

Shock Absorber Unit

● Subject models : RAK50,150,300,800

- ① Mount the shock absorber unit on the square shaft side of the rotary actuator by using mounting holes on the shock absorber body.
- ② For the mounting position, install the shock absorber body above the connection port of the rotary actuator, as shown in the diagram.
- ③ Attach the shock absorber lever by using a hexagon socket head cap mounting bolt (small). At this time, confirm that the vane shaft of the rotary actuator is at the swing start position. (See the position on page 959 "Relationship between Swing Angle and Key Groove Location.")
- ④ The shock absorber lever cannot be inserted at the swing start position since it bumps against the piston on the shock absorber body. Rotate the vane shaft in a counterclockwise direction until it reaches a position where the lever can be inserted.
- ⑤ Do not use the shock absorber as a stopper.

Note : Do not use the shock absorber as a stopper.
For intermediate position stops, always use an external stopper.

Handling precautions

- ① Do not loosen or disassemble any part other than the adjusting needle. Such action could cause oil leakage.
- ② Do not turn the adjusting needle's hexagonal nut, since it is not a lock nut. It could cause oil leakage.
- ③ Avoid use in locations exposed to dust or metal chips, or to fluids such as water or oil. It could result in decreased durability, and/or malfunctions.

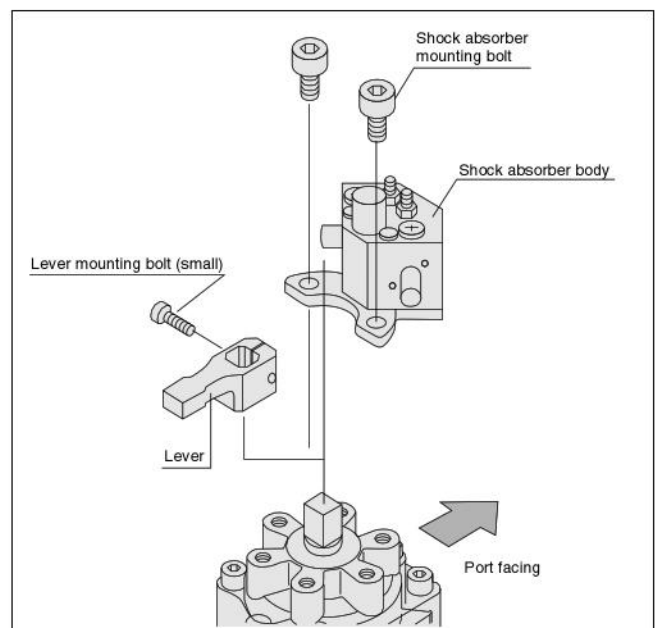

Sensor switch and shock absorber unit

● Subject models : RAK(D)50-150-300

- ① Mount a base bracket and shock absorber, in that order, on the square shaft side of the rotary actuator by using two hexagon socket head cap mounting bolts (large).
- ② For the mounting position, mount the shock absorber body so that it faces in the same direction as the connection port of the rotary actuator, as shown in the diagram.
- ③ Attach the magnet lever by using a hexagon socket head cap mounting bolt (small). At this time, confirm that the vane shaft of the rotary actuator is at the swing start position.
- ④ The shock absorber lever cannot be inserted at the swing start position since it bumps against the piston on the shock absorber body. Rotate the vane shaft in a counterclockwise direction until it reaches a position where the lever can be inserted.
- ⑤ Mount sensor switch brackets on the swing start position and the opposite swing end position. (See the diagram on page 959 "Relationship between Swing Angle and Key Groove Location.")
- ⑥ For sensor switch mounting, moving, and adjusting, and for magnet arm mounting and adjusting, see "Moving and Adjusting Sensor Switch."

Note : Do not use the shock absorber as a stopper. For intermediate position stops, always use an external stopper.

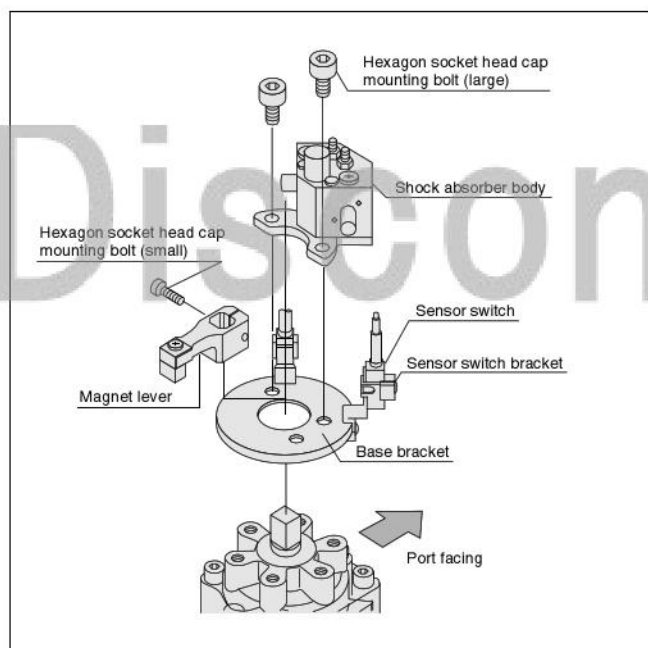

● Subject models : RAK(D)800

- ① Mount a shock absorber on the square shaft side of the rotary actuator by using two hexagon socket head cap mounting bolts (large).
- ② For the mounting position, mount the shock absorber body so that it faces in the same direction as the connection port of the rotary actuator, as shown in the diagram.
- ③ Attach the magnet lever by using a hexagon socket head cap mounting bolt (small). At this time, confirm that the vane shaft of the rotary actuator is at the swing start position. (See the diagram on page 959 "Relationship between Swing Angle and Key Groove Location.")
- ④ The magnet lever cannot be inserted at the swing start position since it bumps against the piston on the shock absorber body. Rotate the vane shaft in a counterclockwise direction until it reaches a position where the lever can be inserted.
- ⑤ The sensor switch brackets should be mounted on the swing start position and the opposite swing end position.
- ⑥ For sensor switch mounting, moving, and adjusting, and for magnet arm mounting and adjusting, see "Moving and Adjusting Sensor Switch."

Note : Do not use the shock absorber as a stopper. For intermediate position stops, always use an external stopper.

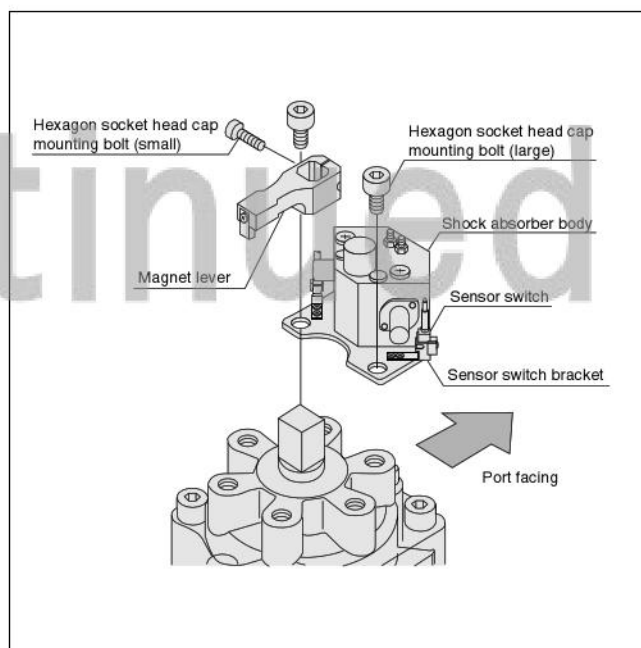

Handling Instructions, and Precautions



Mounting

Shock absorber

1. Do not loosen or disassemble any part other than the adjusting needle. Such action could cause oil leakage.
2. Do not turn the adjusting needle's hexagonal nut, since it is not a lock nut. It could cause oil leakage.
3. Install a cover, etc., or appropriate protective devices when operating in locations near or exposed to excessive dripping water, dripping oil, etc., or large amounts of dust.

Impact energy

1. Find the inertia moment from the size of the load, and confirm whether it is within the load range.
2. Confirm whether it is within the impact angle velocity range.

$$\omega_0 \div 1.2 \omega$$

$$\omega_0$$
 : impact angle velocity (degrees/s)

$$\omega$$
 : Average angle velocity (degrees/s)
3. Find the impact energy from the load and impact angle velocity.

$$E1 = 1/2 J \omega_0^2 \times 10^{-1} (\text{mJ})$$

$$J$$
 : Inertia moment (kg·cm²)

$$\omega_0$$
 : impact angle velocity (rads/s)
4. Find the energy from the rotary actuator torque.

$$E2 = 1/2 T \theta \times 10 (\text{mJ})$$

$$T$$
 : Rotary actuator torque (N·cm)

$$\theta$$
 : Absorption angle (one side) (rads)
5. Confirm that $E1 + E2$ is at or below the maximum energy.
6. Find the energy per minute from the frequency.

$$Em = 2N (E1 + E2)$$

$$N$$
 : Operating frequency (cycles/min)
 Confirm that Em is at or below the maximum energy capacity per minute.
7. In calculating the energy, convert the "degrees" in the impact angle velocity and absorption angle into "rads."

$$1^\circ = 0.0174 \text{ rad}$$

Precautions concerning the load direction

1. Since thrust loads in the axial direction of the vane type rotary actuator could be the cause of improper operations or of reductions in durability, be particularly careful during mounting and use. Although this catalog lists maximum thrust loads, these are reference values, not guaranteed values.
2. While radial loads placed perpendicularly to the axis can be applied as static loads up to the specification values, dynamic loads are limited to within the load of the maximum energy value. Moreover, since eccentric loads placed perpendicular to the axis can result in abnormal friction and damage to the bearings, use flexible couplings wherever possible for connections.
3. In mounting, select loads and couplings that do not place stress or loads on the body.

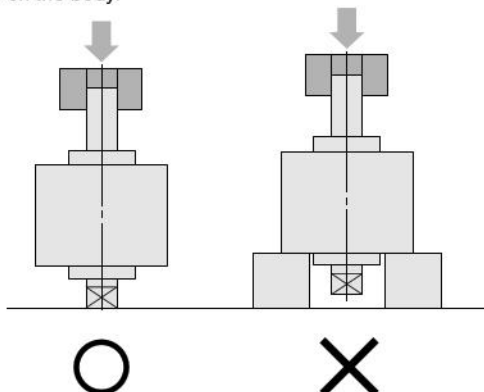

Selection

Selection of swing time

1. Use a swing time that is within the range in the table below. Smooth operation cannot be obtained when used outside of this range.
2. Consult us if a swing time over the range in the table below must be used.

Type	Swing angle		
	90°	180°	270°
RAK50	0.08~0.8	0.16~1.6	0.24~2.4
RAK150	0.12~1.2	0.24~2.4	0.36~3.6
RAK300	0.16~1.6	0.32~3.2	0.48~4.8
RAK800	0.22~2.2	0.44~4.4	0.66~6.6

Remark: The swing time in the above table is the time from the beginning of movement until the swing end.



General precautions

1. Always thoroughly flush out (blowing compressed air) the piping before connecting. Entering of metal chips, sealing tape, rust, etc., generated during plumbing could cause air leakage or other improper operation.
2. Use air for media. Consult us for the use of other media.
3. Do not use when the media or ambient atmosphere contains any of the following substances: organic solvents, phosphorus acid ester type hydraulic oil, sulfurous acid gas, chlorine gas, or acids.
4. Use a cover, etc., for protection when using in locations exposed to dripping water, dripping oil, etc., or to large amounts of dust.