

Rotary Actuators Vane Type

RAG Series

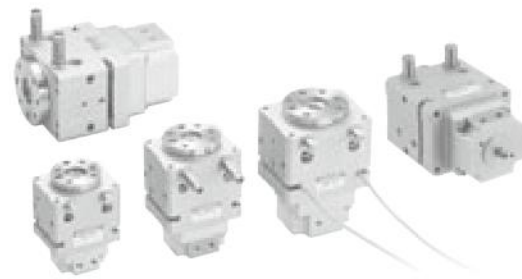

Uses angular bearings (except for RAG1), to achieve high precision and high rigidity.

Two different swing angle types are available, **90°** and **180°**.
 ±5° adjustment at the end of the swing stroke is possible by adjusting the screwed length of the rubber stopper or shock absorber.
 Four different rated torque types are available,
0.1, 0.3, 0.8 and 2.0 N·m [0.07, 0.2, 0.6, 1.5ft·lbf].

Note
 Note: At an operating pressure of 0.5MPa [73psi.]

Demonstrates superior load capacity.

Allowable load

Item	Model	RAG□1	RAG□3	RAG□8	RAG□20
Allowable thrust load W_s	N [lbf]	20[4.5]	60[13.5]	120[27.0]	160[36.0]
Allowable radial load W_R	N [lbf]	20[4.5]	80[18.0]	100[22.5]	120[27.0]
Allowable moment M	N·m [ft·lbf]	0.4[0.30]	0.9[0.66]	1.3[0.96]	3.5[2.58]

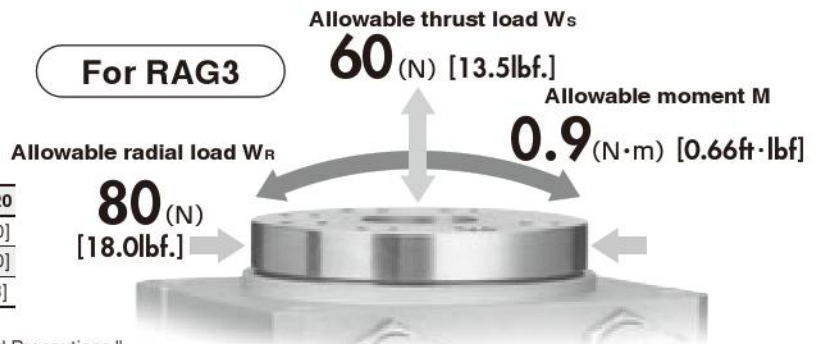

※For details of the allowable load, see p.1308, "Handling Instructions and Precautions."

Four Types of Cushion Mechanisms

Since the rubber stopper and shock absorber use the same sized mounting screw, they are interchangeable (RAG□1 is available with rubber stopper only).



With shock absorbers on both sides With shock absorber on the right side With shock absorber on the left side With rubber stoppers on both sides
 (Mounted at the clockwise rotation end) (Mounted at the counterclockwise rotation end)

Locating dowel pin holes are available on the table top and main body (3 surfaces).

The locating dowel pin and mounting holes are common between 90° and 180° types.

※ For dimension details, see the Dimensions on p.1321 ~ 1324.

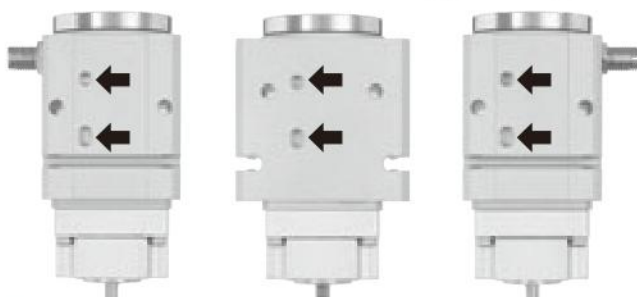
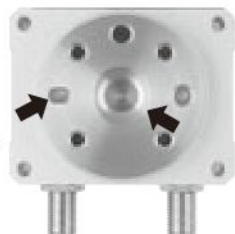

Piping and swing angle adjustment are possible on one surface.

Piping and swing angle adjustment are possible on one surface in all models. By using a vertical lead wire sensor switch, even lead wires can be run out on the same surface.

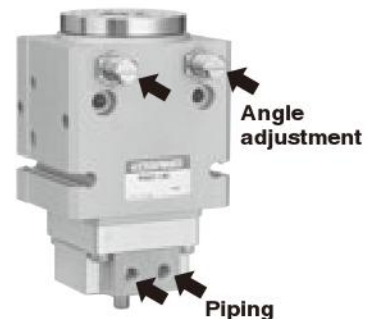

Embedded type sensor switches are available.



- Employs bearings to reduce vibration and deflection, for high precision and high rigidity.
- Easy-to-use table type facilitates workpiece mounting.
- Compatible with embedded type sensor switches.

90° type



180° type



Application example 1

The vacuum pad lifts a workpiece, while the arm enables offset rotation into place.

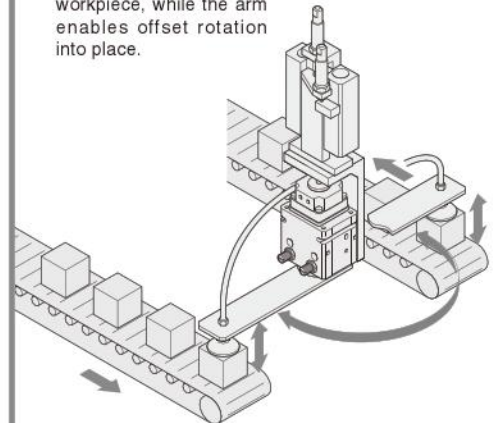

Application example 2

Rotating the workpiece, or tightening the screw (applying a thrust load).

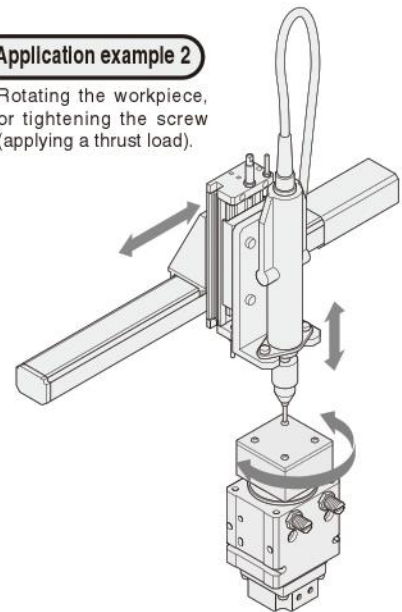

Handling Instructions and Precautions



General precautions

Media

1. Use air for the media. For the use of any other media, consult us.
2. Air used for the rotary actuator should be clean air that contains no deteriorated compressor oil, etc. Install an air filter (filtration of a minimum 40 µm) near the rotary actuator or valve to remove collected liquid or dust. In addition, drain the air filter periodically.

Piping

1. In piping connection with the rotary actuators, flush the tube completely (by blowing compressed air) before piping. Intrusion of machining chips, sealing tape, rust, etc., generated during plumbing could result in air leaks and other defective operations.
2. When screwing in piping or fittings to the actuator, tighten to the appropriate tightening torque shown below.

Connecting thread	Tightening torque N·cm [in·lbf]
M5×0.8	157 [13.9]

Lubrication

The product can be used without lubrication, if lubrication is required, use Turbine Oil Class 1 (ISO VG32) or equivalent. Avoid using spindle oil or machine oil.

Atmosphere

When using in locations subject to dripping water, dripping oil, etc., use a cover to protect the unit.

Start-up

When starting up operations of a device and the rotary actuator by supplying compressed air rapidly, it could not control the speed due to the construction of the rotary actuator, resulting in damage to the device and rotary actuator. When supplying compressed air to the device and rotary actuator where the air has been exhausted, always ensure that the table is in a secure position and cannot be moved further, paying attention to safety, and then apply air pressure from the connection port of not making move the table, first. For the piping port location and swing direction, see p.1320.



Mounting

Mounting

1. The mounting surface should be always flat. Twisting or bending during the mounting could result in air leaks or improper operation.
2. Care should be taken that scratches or dents on the rotary actuator's mounting surface may damage its flatness.
3. Take some locking measures when shocks or vibrations might loosen the bolts.
4. For a workpiece mounting, female threads are available for installing the workpiece in place on the table. Always use bolts so that the screw length is less than the depth of the female thread. When mounting the workpiece, tighten the bolts within the range of the tightening torque.
5. Do not let machining chips or dust enter the product through mounting threads in the table-top surface. Machining chips or dust adhering to the internal bearings could lead to defective operation.

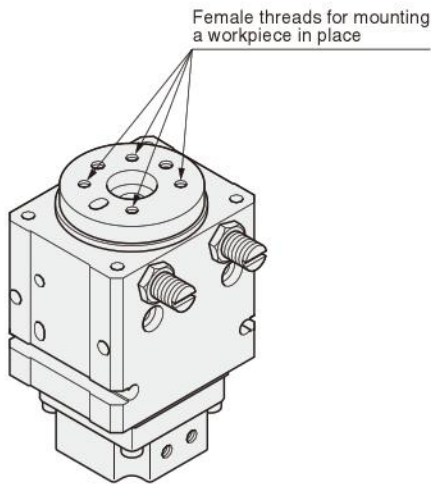

Model	Thread size	Thread depth L mm [in.]	Max. tightening torque N·m [ft·lbf]
RAG□1	M4×0.7	6 [0.236]	2.7 [2.0]
RAG□3			
RAG□8	M5×0.8	8 [0.315]	5.4 [4.0]
RAG□20			

Caution: When using bolts to mount a workpiece in place on the table, hold either the table or workpiece in place during the operation. Holding the body for tightening will apply excessive moment to the stopper, rubber stopper, and shock absorber, resulting in a change of angle.

6. The rotary actuator RAG series can be mounted in either of the ways shown below. When mounting, ensure that the tightening torque is within the range of allowable torque.

Mounting using the through holes on the body (pattern A)

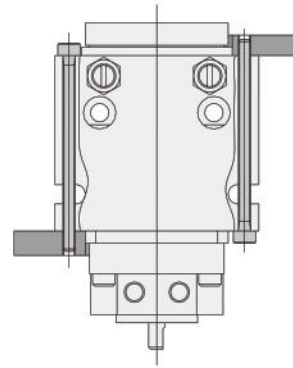

Mounting using the through holes on the body (pattern B)

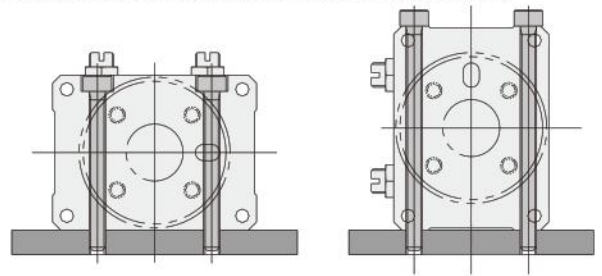

Mounting using the tapped holes on the body

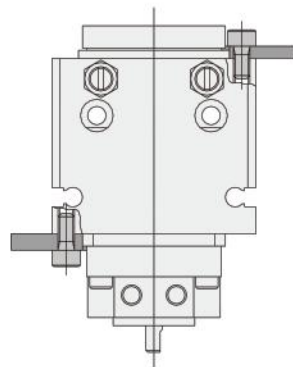

Model	Mounting method	Thread size	Maximum tightening torque N·m [ft·lbf]
RAG□1 RAG□3	Through hole (pattern A)	M3×0.5	1.14 [0.84]
	Through hole (pattern B)	M4×0.7	2.7 [2.0]
	Main body tapped hole	M4×0.7	1.5 [1.1]
RAG□8	Through hole (pattern A)	M4×0.7	1.5 [1.1]
	Through hole (pattern B)	M5×0.8	5.4 [4.0]
	Main body tapped hole	M5×0.8	3.0 [2.2]
RAG□20	Through hole (pattern A)	M5×0.8	5.4 [4.0]
	Through hole (pattern B)	M6×1.0	9.2 [6.8]
	Main body tapped hole	M6×1.0	5.2 [3.8]

Handling Instructions and Precautions

Rubber stopper and shock absorber replacement instructions

- When replacing the rubber stopper or shock absorber, refer to the Swing Angle Range and Swing Direction on p.1320 to perform mounting. If the stopper under the table is not in the correct position, it could result in incorrect swing angle or damage. Moreover, never use the rotary actuator with the rubber stopper or shock absorber removed. As noted above, it could lead to incorrect swing angle and will be unable to absorb kinetic energy, resulting in damage to the rotary actuator.
- Loosen and remove the mounting nut of the rubber stopper or shock absorber. Screw the new rubber stopper or shock absorber into the proper position, and then tighten the mounting nut and secure it in place. When tightening the nut, ensure that the tightening torque is within the range of setting values.

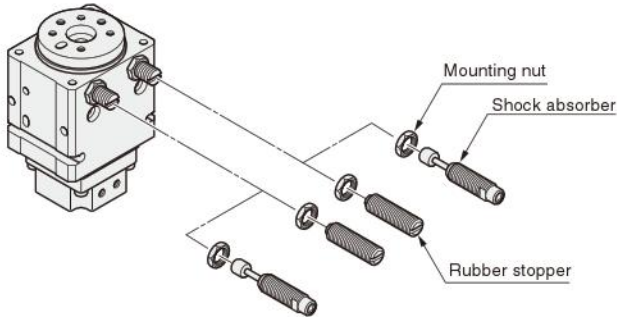

Swing angle adjustment

- The rotary actuators RAG series uses rubber stoppers or shock absorbers for angle adjustment, in the ranges shown on p.1320. For both clockwise and counterclockwise rotation, rotating the rubber stopper or shock absorber to the right (clockwise) will reduce the swing angle. After completing angle adjustment, tighten the nut and secure the rubber stopper or shock absorber in place.
- Always keep the swing angle within the specified range for use. For the shock absorber, in particular, when the angle between the applied load direction and the center line of the shock absorber exceeds the allowable angle variation, the product could be damaged.
- The rubber stoppers or shock absorbers are only temporarily tightened at shipping. For actual use, always tighten the nuts to secure the rubber stoppers or shock absorbers in place.
- When tightening the nut, ensure that the tightening torque is within the range shown below.

Model	Nut size	Maximum tightening torque N·m [ft·lbf]
RAG□1	M6×0.75	0.85 [0.63]
RAG□3	M8×0.75	2.45 [1.81]
RAG□8		
RAG□20	M10×1.0	6.37 [4.70]

Air Consumption

● RAG□1

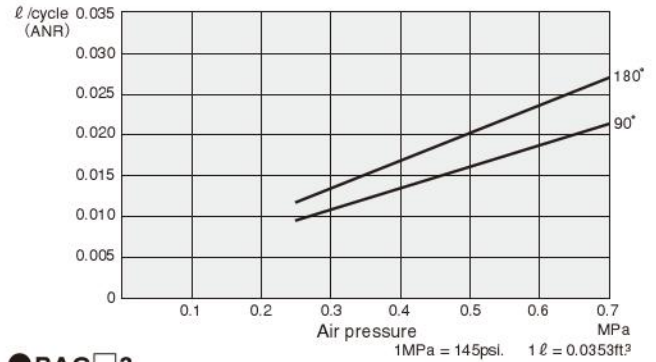

● RAG□3

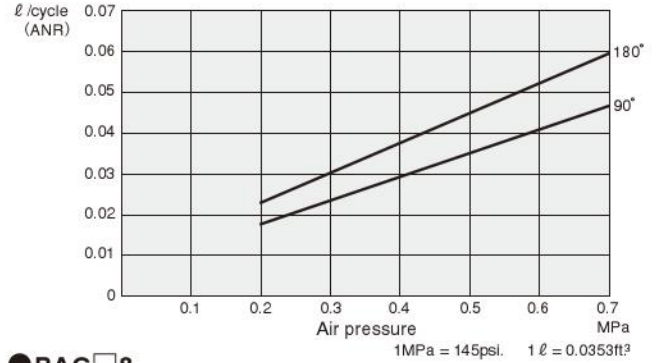

● RAG□8

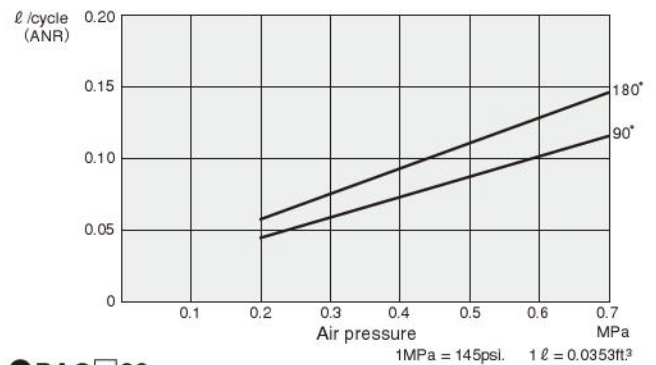

● RAG□20

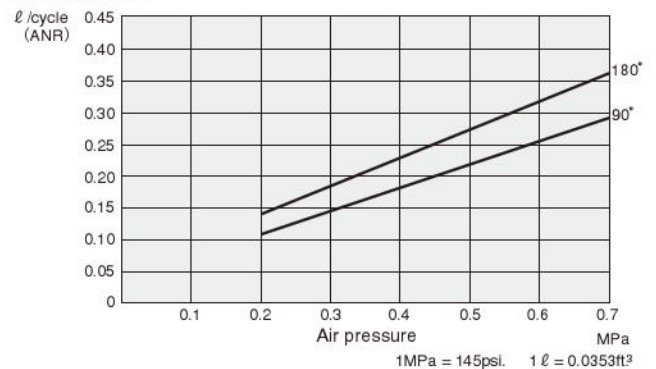

Air consumption per 1 cycle of the rotary actuator can be found by the following equation.

$$Q = 2 \times V \times 10^{-3} \times \frac{P + 0.1013}{0.1013}$$

Q : Air consumption per cycle [l /cycle(ANR)]

V : Internal volume (cm³)

P : Air pressure (MPa)

1 l = 0.0353 ft³, 1cm³ = 0.061 in³, 1MPa = 145psi.
cm³ [in³]

Model	Internal volume	
	90°	180°
RAG□1	1.4 [0.085]	1.7 [0.104]
RAG□3	3.0 [0.183]	3.8 [0.232]
RAG□8	7.4 [0.451]	9.2 [0.561]
RAG□20	18.1 [1.104]	22.7 [1.385]

Handling Instructions and Precautions

● Allowable load

Item	Model	RAG□1	RAG□3	RAG□8	RAG□20
Allowable thrust load W_s	N [lbf]	20[4.5]	60 [13.5]	120 [27.0]	160 [36.0]
Allowable radial load W_R	N [lbf]	20[4.5]	80 [18.0]	100 [22.5]	120 [27.0]
Allowable moment M	N·m [ft·lbf]	0.4[0.30]	0.9 [0.66]	1.3 [0.96]	3.5 [2.58]

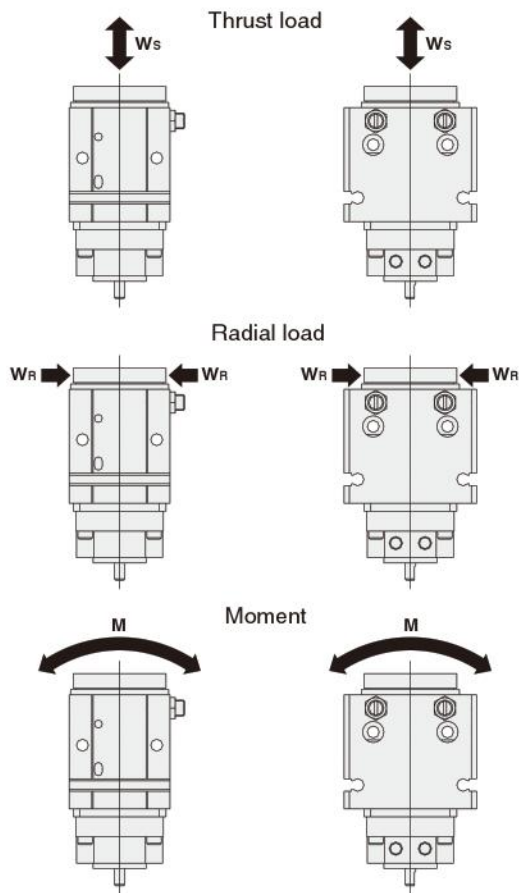

● Effective torque

RAG□1

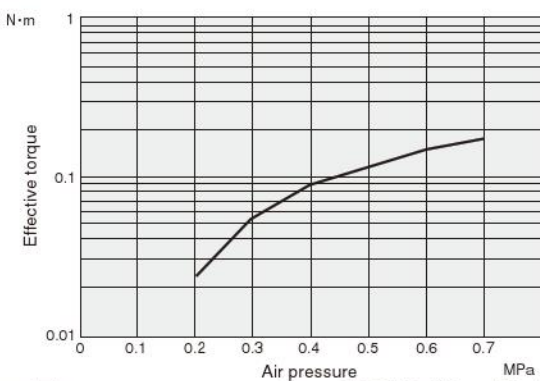

RAG□3

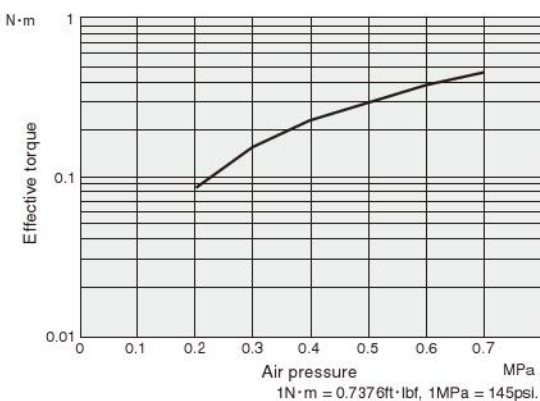

RAG□8

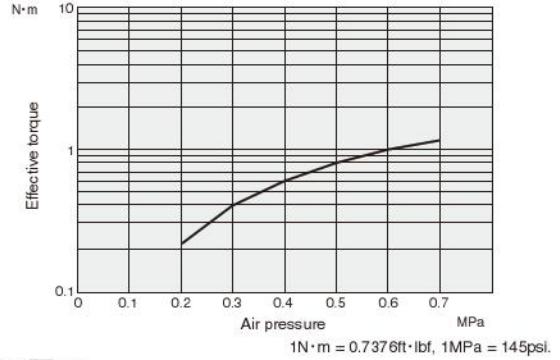

RAG□20

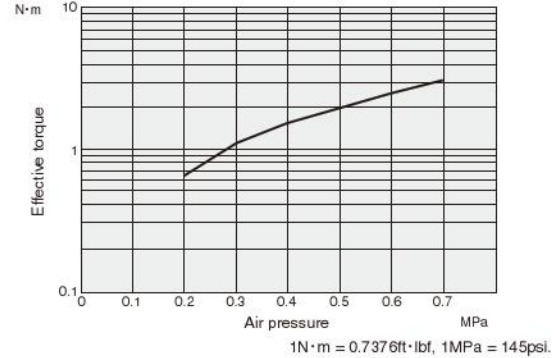

● Table displacement caused by moment

In the rotary actuators RAG series, mounting a plate and applying moment on it, and then measure the displacement at 100mm [3.94in.] position from the rotation center.

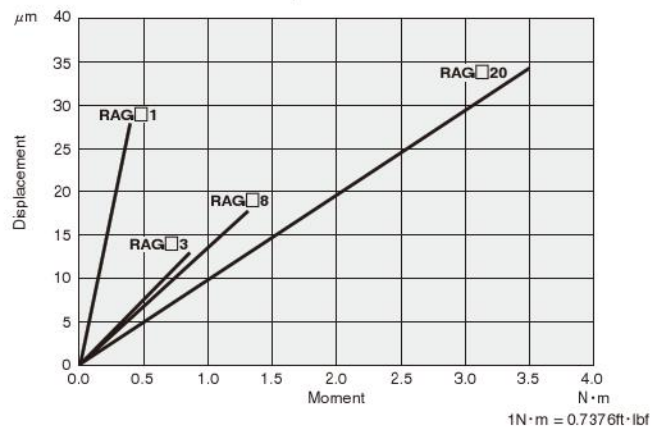
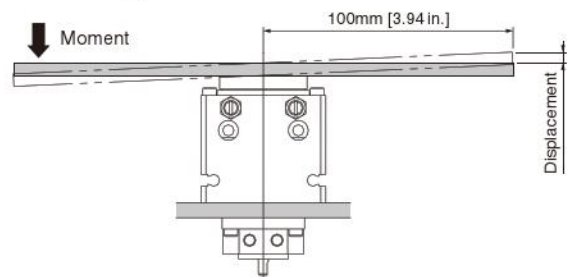

● Deflection accuracy : Table displacement on 180° swing

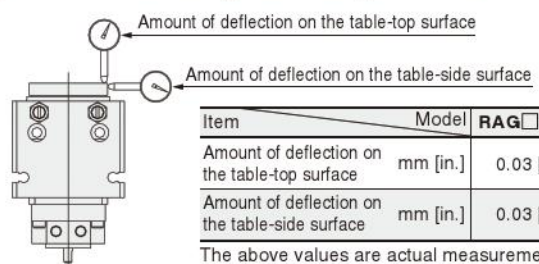

Item	Model	RAG□1, 3, 8, 20
Amount of deflection on the table-top surface	mm [in.]	0.03 [0.0012]
Amount of deflection on the table-side surface	mm [in.]	0.03 [0.0012]

The above values are actual measurement values, and are not intended to be guaranteed values.

Selection

Caution: For the load and swing time, follow the below "Model selection procedure" to select within the range of specified values. Moreover, about 80% of the allowable values is recommended to use in applications. By using these values, adverse effects on cylinders and guides can be a minimum.

● Model selection procedure

1. Check the application conditions

Check the following items ①~④

- ① Swing angle (90° or 180°)
- ② Swing time (s)
- ③ Applied pressure (MPa)
- ④ Workpiece shape and materials
- ⑤ Mounting direction

2. Check the swing time

Check the swing time in 1—② is within the swing time adjustment range in the specification.

Angle	Swing time (s)			
	RAG□1	RAG□3	RAG□8	RAG□20
90°	0.05~0.25	0.05~0.4	0.05~0.5	0.06~0.6
180°	0.1~0.5	0.1~0.8	0.1~1.0	0.12~1.2

Note: The swing time is obtained when using the rubber stopper with no load at 0.5MPa condition.

3. Select torque size (select model)

Find the torque T_A required for rotating the workpiece.

$$T_A = I \dot{\omega} K$$

T_A : Torque (N·m)
 I : Mass moment of inertia (kg·m²)
 Use the equations on p.1311~1314 to find.
 $\dot{\omega}$: Uniform angular acceleration (rad/s²)
 K : Marginal coefficient 5
 θ : Swing angle (rad)
 90°→1.57rad
 180°→3.14rad
 t : Swing time (s)

$$\dot{\omega} = \frac{2\theta}{t^2}$$

Select the model secures the required torque T_A by using the applied pressure checked in 1—③, from among the effective torque graph on p.1308.

4. Check the kinetic energy

If kinetic energy exceeds the allowable energy, the actuator could be damaged. Always select a model so that the energy lies within the allowable energy range. When the kinetic energy is large, use a model with shock absorber (-SS2, -SSR, or -SSL). For the allowable kinetic energy, see Table 1.

Find the kinetic energy.

● With rubber stopper

$$E = \frac{1}{2} \times I \times \omega^2$$

E : Kinetic energy (J)
 I : Mass moment of inertia (kg·m²)
 Use the equations on p.1311~1314 to find.
 ω : Angular velocity (rad/s)
 θ : Swing angle (rad)
 90°→1.57rad
 180°→3.14rad
 t : Swing time (s)
 E_a : Allowable energy with rubber stopper
 ... See Table 1.

$$\omega = \frac{2\theta}{t}$$

$$E < E_a$$

● Model selection procedure

1. Check the application conditions

Check the following items ①~④

- ① Swing angle (90° or 180°)
- ② Swing time [sec.]
- ③ Applied pressure [psi.]
- ④ Workpiece shape and materials
- ⑤ Mounting direction

2. Check the swing time

Check the swing time in 1—② is within the swing time adjustment range in the specification.

Angle	Swing time [sec.]			
	RAG□1	RAG□3	RAG□8	RAG□20
90°	0.05~0.25	0.05~0.4	0.05~0.5	0.06~0.6
180°	0.1~0.5	0.1~0.8	0.1~1.0	0.12~1.2

Note: The swing time is obtained when using the rubber stopper with no load at 73psi. condition.

3. Select torque size (select model)

Find the torque T'_A required for rotating the workpiece.

$$T'_A = I' \dot{\omega}$$

T'_A : Torque [ft·lbf]
 I' : Mass moment of inertia [lbf·ft·sec.²]
 Use the equations on p.1311~1314 to find.
 $\dot{\omega}$: Uniform angular acceleration [rad/sec.²]
 K : Marginal coefficient 5
 θ : Swing angle [rad]
 90°→1.57rad
 180°→3.14rad
 t : Swing time [sec.]

$$\dot{\omega} = \frac{2\theta}{t^2}$$

Select the model secures the required torque T'_A by using the applied pressure checked in 1—③, from among the effective torque graph on p.1308.

4. Check the kinetic energy

If kinetic energy exceeds the allowable energy, the actuator could be damaged. Always select a model so that the energy lies within the allowable energy range. When the kinetic energy is large, use a model with shock absorber (-SS2, -SSR, or -SSL). For the allowable kinetic energy, see Table 1.

Find the kinetic energy.

● With rubber stopper

$$E' = \frac{1}{2} \times I' \times \omega^2$$

E' : Kinetic energy [ft·lbf]
 I' : Mass moment of inertia [lbf·ft·sec.²]
 Use the equations on p.1311~1314 to find.
 ω : Angular velocity [rad/sec.]
 θ : Swing angle [rad]
 90°→1.57rad
 180°→3.14rad
 t : Swing time [sec.]
 E'_a : Allowable energy with rubber stopper
 ... See Table 1.

$$\omega = \frac{2\theta}{t}$$

$$E' < E'_a$$

●With shock absorber

① Find the equivalent mass m_1 .

$$m_1 = \frac{I}{R^2}$$

m_1 : Equivalent mass (kg)
 I : Mass moment of inertia (kg·m²)

② Find the equivalent mass m_2 .

$$m_2 = \frac{2 \times T \times L}{R^3 \times \omega^2}$$

Use the equations on p.1311~1314 to find.
 R : Distance from the rotation center to the impact point (m) ... See Fig.1 and Table 2.

m_2 : Equivalent mass (kg)

T : Effective torque (N·m)

Use the effective torque graph to find.

L : Shock absorber stroke (m) ... See Table 2.

ω : Angular velocity (rad/s)

θ : Swing angle (rad)

90°→1.57rad

180°→3.14rad

t : Swing time (s)

m : Total mass (kg)

V : Impact velocity (m/s)

E : Kinetic energy (J)

E_a : Allowable energy with shock absorber ... See Table 1.

$$\omega = \frac{2\theta}{t}$$

③ Find the total mass m .

$$m = m_1 + m_2$$

④ Find the impact velocity.

$$V = R \times \omega$$

⑤ Find the kinetic energy.

$$E = \frac{1}{2} \times m \times V^2$$

$$E < E_a$$

Table 1. Allowable energy E_a

Model	Allowable energy with rubber stopper (J)	Allowable energy with shock absorber (J)
RAG□1	0.003	—
RAG□3	0.005	0.30
RAG□8	0.008	0.53
RAG□20	0.030	1.14

Fig.1 R: Distance from the rotation center to the impact point

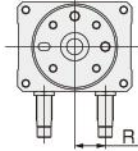

Table 2.

Model	Distance R from the rotation center to the impact point (m)	Shock absorber stroke L (m)	Shock absorber model
RAG□3	0.015	0.005	KSHAR5×5-D
RAG□8	0.018	0.005	KSHAR5×5-E
RAG□20	0.021	0.008	KSHAR6×8-F

5. Check the load ratio

Check that the total sum of the load ratio does not exceed 1.

For the allowable load, see Table 3 (For the load direction, see the allowable load on p.1308.)

$$\frac{W_s}{W_{s \text{ MAX}}} + \frac{W_R}{W_{R \text{ MAX}}} + \frac{M}{M_{\text{MAX}}} \leq 1$$

Table 3. Allowable load

Model	Thrust load $W_{s \text{ MAX}}$ (N)	Radial load $W_{R \text{ MAX}}$ (N)	Moment M_{MAX} (N·m)
RAG□1	20	20	0.4
RAG□3	60	80	0.9
RAG□8	120	100	1.3
RAG□20	160	120	3.5

6. Judgement whether the unit is usable or not

The unit is usable if it satisfies both 4. Kinetic energy and 5. Load ratio.

$$E < E_a$$

$$\text{Total sum of load ratio} \leq 1$$

●With shock absorber

① Find the equivalent weight w_1 .

$$w_1 = \frac{I'}{R'^2} \times 32.2$$

w_1 : Equivalent weight [lbf.]
 I' : Mass moment of inertia [lbf·ft·sec²]

② Find the equivalent weight w_2 .

$$w_2 = \frac{2 \times T' \times L' \times 32.2}{R'^3 \times \omega'^2}$$

Use the equations on p.1311~1314 to find.
 R' : Distance from the rotation center to the impact point [ft] ... See Fig.1 and Table 2.

w_2 : Equivalent weight [lbf.]

T' : Effective torque [ft·lbf]

Use the effective torque graph to find.

L' : Shock absorber stroke [ft.] ... See Table 2.

ω' : Angular velocity [rad/sec.]

θ : Swing angle [rad]

90°→1.57rad

180°→3.14rad

t : Swing time [sec.]

w : Total weight [lbf.]

V' : Impact velocity [ft./sec.]

E' : Kinetic energy [ft·lbf]

E'_a : Allowable energy with shock absorber ... See Table 1.

$$\omega = \frac{2\theta}{t}$$

③ Find the total weight w .

$$w = w_1 + w_2$$

④ Find the impact velocity.

$$V' = R' \times \omega'$$

⑤ Find the kinetic energy.

$$E' = \frac{1}{2} \times \frac{w}{32.2} \times V'^2$$

$$E' < E'_a$$

Table 1. Allowable energy E'_a

Model	Allowable energy with rubber stopper [ft·lbf]	Allowable energy with shock absorber [ft·lbf]
RAG□1	0.002	—
RAG□3	0.004	0.22
RAG□8	0.006	0.39
RAG□20	0.022	0.84

Fig.1 R': Distance from the rotation center to the impact point

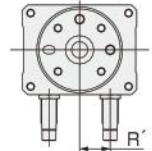

Table 2.

Model	Distance R' from the rotation center to the impact point [in.]	Shock absorber stroke L' [in.]	Shock absorber model
RAG□3	0.59	0.20	KSHAR5×5-D
RAG□8	0.71	0.20	KSHAR5×5-E
RAG□20	0.83	0.31	KSHAR6×8-F

5. Check the load ratio

Check that the total sum of the load ratio does not exceed 1.

For the allowable load, see Table 3 (For the load direction, see the allowable load on p.1308.)

$$\frac{W'_s}{W'_{s \text{ MAX}}} + \frac{W'_R}{W'_{R \text{ MAX}}} + \frac{M'}{M'_{\text{MAX}}} \leq 1$$

Table 3. Allowable load

Model	Thrust load $W'_{s \text{ MAX}}$ [lbf.]	Radial load $W'_{R \text{ MAX}}$ [lbf.]	Moment M'_{MAX} [ft·lbf]
RAG□1	4.5	4.5	0.30
RAG□3	13.5	18.0	0.66
RAG□8	27.0	22.5	0.96
RAG□20	36.0	27.0	2.58

6. Judgement whether the unit is usable or not

The unit is usable if it satisfies both 4. Kinetic energy and 5. Load ratio.

$$E' < E'_a$$

$$\text{Total sum of load ratio} \leq 1$$

Diagram for calculating mass moment of inertia

[When the rotation axis passes through the workpiece]

● Disk

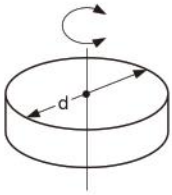

● Diameter	d (m)	■ Mass moment of inertia I (kg·m ²)	■ Rotating radius
● Mass	m (kg)	$I = \frac{md^2}{8}$	$\frac{d^2}{8}$
● Diameter	d [ft.]	■ Mass moment of inertia I' [lbf·ft·sec ²]	■ Rotating radius
● Weight	w [lbf.]	$I' = \frac{wd^2}{8 \times 32.2}$	$\frac{d^2}{8}$

Remark: No particular mounting direction.
Consider separately for sliding use.

● Stepped disk

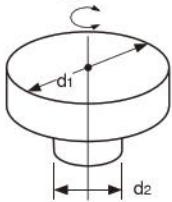

● Diameter	d ₁ (m) d ₂ (m)	■ Mass moment of inertia I (kg·m ²)	■ Rotating radius
● Mass	d ₁ portion m ₁ (kg) d ₂ portion m ₂ (kg)	$I = \frac{1}{8}(m_1d_1^2 + m_2d_2^2)$	$\frac{d_1^2 + d_2^2}{8}$
● Diameter	d ₁ [ft.] d ₂ [ft.]	■ Mass moment of inertia I' [lbf·ft·sec ²]	■ Rotating radius
● Weight	d ₁ portion w ₁ [lbf.] d ₂ portion w ₂ [lbf.]	$I' = \frac{1}{8 \times 32.2} \times (w_1d_1^2 + w_2d_2^2)$	$\frac{d_1^2 + d_2^2}{8}$

Remark: The d₂ portion can be negligible when it is much smaller than the d₁ portion.

● Bar (when the rotation center passes through the edge)

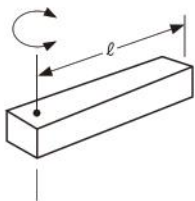

● Bar length	l (m)	■ Mass moment of inertia I (kg·m ²)	■ Rotating radius
● Mass	m (kg)	$I = \frac{m l^2}{3}$	$\frac{l^2}{3}$
● Bar length	l [ft.]	■ Mass moment of inertia I' [lbf·ft·sec ²]	■ Rotating radius
● Weight	w [lbf.]	$I' = \frac{w l^2}{3 \times 32.2}$	$\frac{l^2}{3}$

Remark: Mounting direction is horizontal.
If the mounting direction is vertical, the swing time will change.

● Slender rod

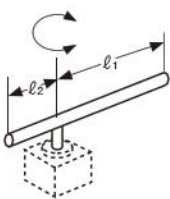

● Rod length	l ₁ (m) l ₂ (m)	■ Mass moment of inertia I (kg·m ²)	■ Rotating radius
● Mass	m ₁ (kg) m ₂ (kg)	$I = \frac{m_1 l_1^2}{3} + \frac{m_2 l_2^2}{3}$	$\frac{l_1^2 + l_2^2}{3}$
● Rod length	l ₁ [ft.] l ₂ [ft.]	■ Mass moment of inertia I' [lbf·ft·sec ²]	■ Rotating radius
● Weight	w ₁ [lbf.] w ₂ [lbf.]	$I' = \frac{w_1 l_1^2}{3 \times 32.2} + \frac{w_2 l_2^2}{3 \times 32.2}$	$\frac{l_1^2 + l_2^2}{3}$

Remark: Mounting direction is horizontal.
If the mounting direction is vertical, the swing time will change.

● Bar (when the rotation center passes through the center of gravity)

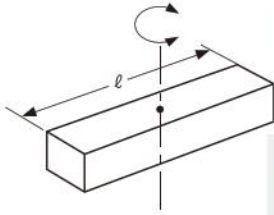

● Bar length	l (m)	■ Mass moment of inertia I ($\text{kg}\cdot\text{m}^2$)	■ Rotating radius
● Mass	m (kg)	$I = \frac{m l^2}{12}$	$\frac{l^2}{12}$
● Bar length	l [ft.]	■ Mass moment of inertia I' [$\text{lb}\cdot\text{ft}\cdot\text{sec}^2$]	■ Rotating radius
● Weight	w [lbf.]	$I' = \frac{w l^2}{12 \times 32.2}$	$\frac{l^2}{12}$

Remark: No particular mounting direction.

● Thin rectangular plate (rectangular solid)

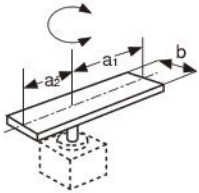

● Plate length	a_1 (m) a_2 (m)	■ Mass moment of inertia I ($\text{kg}\cdot\text{m}^2$)	■ Rotating radius
● Length of side	b (m)	$I = \frac{m_1}{12} (4a_1^2 + b^2) + \frac{m_2}{12} (4a_2^2 + b^2)$	$\frac{(4a_1^2 + b^2) + (4a_2^2 + b^2)}{12}$
● Mass	m_1 (kg) m_2 (kg)		
● Plate length	a_1 [ft.] a_2 [ft.]	■ Mass moment of inertia I' [$\text{lb}\cdot\text{ft}\cdot\text{sec}^2$]	■ Rotating radius
● Length of side	b [ft.]	$I' = \frac{w_1}{12 \times 32.2} (4a_1^2 + b^2) + \frac{w_2}{12 \times 32.2} (4a_2^2 + b^2)$	$\frac{(4a_1^2 + b^2) + (4a_2^2 + b^2)}{12}$
● Weight	w_1 [lbf.] w_2 [lbf.]		

Remark: Mounting direction is horizontal.
If the mounting direction is vertical, the swing time will change.

● Rectangular parallelepiped

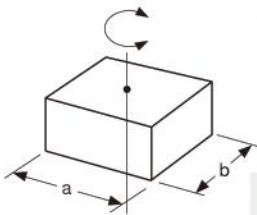

● Length of sides	a (m) b (m)	■ Mass moment of inertia I ($\text{kg}\cdot\text{m}^2$)	■ Rotating radius
● Mass	m (kg)	$I = \frac{m}{12} (a^2 + b^2)$	$\frac{a^2 + b^2}{12}$
● Length of sides	a [ft.] b [ft.]	■ Mass moment inertia I' [$\text{lb}\cdot\text{ft}\cdot\text{sec}^2$]	■ Rotating radius
● Weight	w [lbf.]	$I' = \frac{w}{12 \times 32.2} (a^2 + b^2)$	$\frac{a^2 + b^2}{12}$

Remark: No particular mounting direction.
Consider separately for sliding use.

● **Concentrated load**

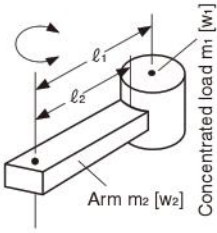

- Shape of concentrated load
- Distance to center of gravity of concentrated load l_1 (m)
- Length of arm l_2 (m)
- Mass of concentrated load m_1 (kg)
- Mass of arm m_2 (kg)

■ Mass moment of inertia I ($\text{kg}\cdot\text{m}^2$)

$$I = m_1 k^2 + m_1 l_1^2 + \frac{m_2 l_2^2}{3}$$

Rotating radius: k^2 is calculated according to shape of the concentrated load.
 Remark: Mounting direction is horizontal. When m_2 is much smaller than m_1 , calculate as $m_2 = 0$.

- Shape of concentrated load
- Distance to center of gravity of concentrated load l_1 [ft.]
- Length of arm l_2 [ft.]
- Weight of concentrated load w_1 [lbf.]
- Weight of arm w_2 [lbf.]

■ Mass moment of inertia I' [$\text{lbf}\cdot\text{ft}\cdot\text{sec}^2$]

$$I' = \frac{w_1 k^2}{32.2} + \frac{w_1 l_1^2}{32.2} + \frac{w_2 l_2^2}{32.2 \times 3}$$

Rotating radius: k^2 is calculated according to shape of the concentrated load.
 Remark: Mounting direction is horizontal. When w_2 is much smaller than w_1 , calculate as $w_2 = 0$.

● **Gear** Equation for calculating the load J_L with respect to rotary actuator axis when transmitted by gears

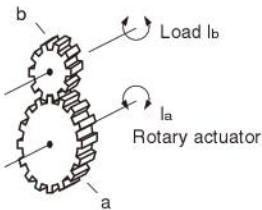

- Gear Rotary actuator side a
Load side b
- Inertia moment of load $N\cdot m$

■ Mass moment of inertia I ($\text{kg}\cdot\text{m}^2$)

Mass moment of inertia of load with respect to rotary actuator axis

$$I_a = \left(\frac{a}{b}\right)^2 I_b$$

- Gear Rotary actuator side a
Load side b
- Inertia moment of load $\text{ft}\cdot\text{lbf}$

■ Mass moment of inertia I' [$\text{lbf}\cdot\text{ft}\cdot\text{sec}^2$]

Mass moment of inertia of load with respect to rotary actuator axis

$$I_a = \left(\frac{a}{b}\right)^2 I_b$$

Remark: If the shapes of the gears are too large, the mass moment of inertia of the gears must be also taken into consideration.

[When the rotation axis is offset from the workpiece]

● Rectangular parallelepiped

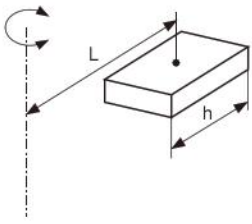

- Length of side h (m)
- Distance from rotation axis to the center of load L (m)
- Mass m (kg)

■ Mass moment of inertia I (kg·m²)

$$I = \frac{mh^2}{12} + mL^2$$

- Length of side h [ft.]
- Distance from rotation axis to the center of load L [ft.]
- Weight w [lbf.]

■ Mass moment of inertia I' [lbf·ft·sec²]

$$I' = \frac{wh^2}{32.2 \times 12} + \frac{wL^2}{32.2}$$

Remark: Same for cube.

● Hollow rectangular parallelepiped

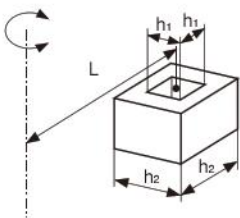

- Length of side h₁ (m)
- h₂ (m)
- Distance from rotation axis to the center of load L (m)
- Mass m (kg)

■ Mass moment of inertia I (kg·m²)

$$I = \frac{m}{12} (h_2^2 + h_1^2) + mL^2$$

- Length of side h₁ [ft.]
- h₂ [ft.]
- Distance from rotation axis to the center of load L [ft.]
- Weight w [lbf.]

■ Mass moment of inertia I' [lbf·ft·sec²]

$$I' = \frac{w(h_2^2 + h_1^2)}{32.2 \times 12} + \frac{wL^2}{32.2}$$

Remark: Cross-section is square only.

● Circular cylinder

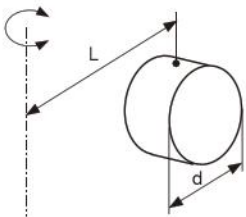

- Diameter d (m)
- Distance from rotation axis to the center of load L (m)
- Mass m (kg)

■ Mass moment of inertia I (kg·m²)

$$I = \frac{md^2}{16} + mL^2$$

- Diameter d [ft.]
- Distance from rotation axis to the center of load L [ft.]
- Weight w [lbf.]

■ Mass moment of inertia I' [lbf·ft·sec²]

$$I' = \frac{wd^2}{32.2 \times 16} + \frac{wL^2}{32.2}$$

● Hollow circular cylinder

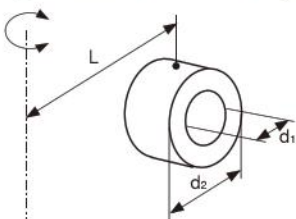

- Diameter d₁ (m)
- d₂ (m)
- Distance from rotation axis to the center of load L (m)
- Mass m (kg)

■ Mass moment of inertia I (kg·m²)

$$I = \frac{m}{16} (d_2^2 + d_1^2) + mL^2$$

- Diameter d₁ [ft.]
- d₂ [ft.]
- Distance from rotation axis to the center of load L [ft.]
- Weight w [lbf.]

■ Mass moment of inertia I' [lbf·ft·sec²]

$$I' = \frac{w(d_2^2 + d_1^2)}{32.2 \times 16} + \frac{wL^2}{32.2}$$

● Calculation example

When the workpiece is a cube on a rectangular plate (mm)

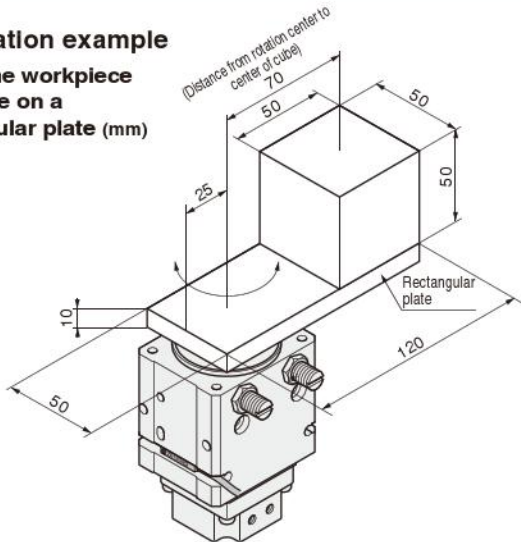

1. Check the application conditions

- ① Swing angle : 90°
- ② Swing time : 0.4(s)
- ③ Applied pressure : 0.5 (MPa)
- ④ Workpiece shape: Shown in the above
Workpiece material
Rectangular plate : Aluminum alloy (Specific gravity = 2.68×10³ kg/m³)
Cube : Steel (Specific gravity = 7.85×10³ kg/m³)
- ⑤ Mounting direction : Horizontal

2. Check the swing time

The swing time is 0.5s/90°, which means there is no problem in the models larger than RAG□3.

3. Select torque size

Firstly calculate the mass moment of inertia.

Rectangular plate

$$m_1 = 0.05 \times (0.12 - 0.025) \times 0.01 \times 2.68 \times 10^3 = 0.127 \text{ (kg)}$$

$$m_2 = 0.05 \times 0.025 \times 0.01 \times 2.68 \times 10^3 = 0.034 \text{ (kg)}$$

$$I_1 = \frac{0.127}{12} \{4 \times (0.12 - 0.025)^2 + 0.05^2\} + \frac{0.034}{12} \{4 \times 0.025^2 + 0.05^2\}$$

$$= 0.42 \times 10^{-3} \text{ (kg} \cdot \text{m}^2) \dots \text{①}$$

Cube

$$m_3 = 0.05 \times 0.05 \times 0.05 \times 7.85 \times 10^3 = 0.981 \text{ (kg)}$$

$$I_2 = \frac{0.981 \times 0.05^2}{12} + 0.981 \times 0.07^2$$

$$= 5.01 \times 10^{-3} \text{ (kg} \cdot \text{m}^2) \dots \text{②}$$

From ① and ②, the total mass moment of inertia I is

$$I = I_1 + I_2$$

$$= 0.42 \times 10^{-3} + 5.01 \times 10^{-3}$$

$$= 5.43 \times 10^{-3} \text{ (kg} \cdot \text{m}^2) \dots \text{③}$$

According to the given conditions, $\theta = 90^\circ$, $t = 0.4$ (s) therefore, the uniform angular acceleration $\dot{\omega}$ is

$$\dot{\omega} = \frac{2 \times 1.57}{0.4^2} = 19.625 \text{ (rad/s}^2) \dots \text{④}$$

From ③ and ④, the required torque T_A is

$$T_A = 5.43 \times 10^{-3} \times 19.625 \times 5$$

$$= 0.533 \text{ (N} \cdot \text{m)} \dots \text{⑤}$$

From the Effective torque graph on p.1308, select a model where the torque is more than 0.533 (N·m) at 0.5 MPa.

● Calculation example

When the workpiece is a cube on a rectangular plate [In.]

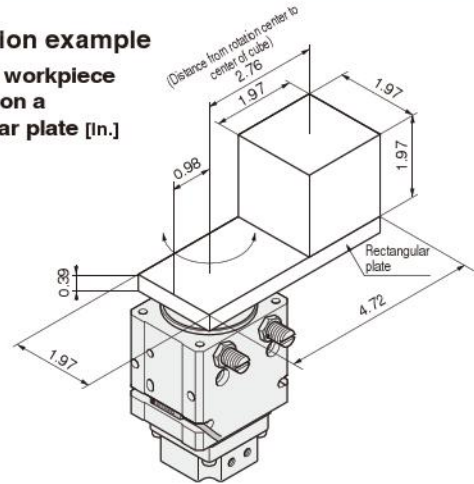

1. Check the application conditions

- ① Swing angle : 90°
- ② Swing time : 0.4[sec.]
- ③ Applied pressure : 73 [psi.]
- ④ Workpiece shape: Shown in the above
Workpiece material
Rectangular plate: Aluminum alloy (Specific gravity = 167 lbf/ft³)
Cube: Steel (Specific gravity = 490 lbf/ft³)
- ⑤ Mounting direction : Horizontal

2. Check the swing time

The swing time is 0.5sec./90°, which means there is no problem in the models larger than RAG□3.

3. Select torque size

Firstly calculate the mass moment of inertia.

Rectangular plate

$$w_1 = \frac{1.97}{12} \times \frac{(4.72 - 0.98)}{12} \times \frac{0.39}{12} \times 167 = 0.278 \text{ [lbf.]}$$

$$w_2 = \frac{1.97}{12} \times \frac{0.98}{12} \times \frac{0.39}{12} \times 167 = 0.073 \text{ [lbf.]}$$

$$I'_1 = \frac{0.278}{12 \times 32.2} \{4 \times \left(\frac{4.72 - 0.98}{12}\right)^2 + \left(\frac{1.97}{12}\right)^2\} + \frac{0.073}{12 \times 32.2} \{4 \times \left(\frac{0.98}{12}\right)^2 + \left(\frac{1.97}{12}\right)^2\}$$

$$= 0.31 \times 10^{-3} \text{ [lbf} \cdot \text{ft} \cdot \text{sec}^2] \dots \text{①}$$

Cube

$$w_3 = \frac{1.97}{12} \times \frac{1.97}{12} \times \frac{1.97}{12} \times 490 = 2.17 \text{ [lbf.]}$$

$$I'_2 = \frac{2.17}{12 \times 32.2} \times \left(\frac{1.97}{12}\right)^2 + \frac{2.17}{32.2} \times \left(\frac{2.76}{12}\right)^2$$

$$= 3.71 \times 10^{-3} \text{ [lbf} \cdot \text{ft} \cdot \text{sec}^2] \dots \text{②}$$

From ① and ②, the total mass moment of inertia I' is

$$I' = I'_1 + I'_2$$

$$= 0.31 \times 10^{-3} + 3.71 \times 10^{-3}$$

$$= 4.02 \times 10^{-3} \text{ [lbf} \cdot \text{ft} \cdot \text{sec}^2] \dots \text{③}$$

According to the given conditions, $\theta = 90^\circ$, $t = 0.4$ [sec.] therefore, the uniform angular acceleration $\dot{\omega}$ is

$$\dot{\omega} = \frac{2 \times 1.57}{0.4^2} = 19.625 \text{ [rad/sec}^2] \dots \text{④}$$

From ③ and ④, the required torque T'_A is

$$T'_A = 4.02 \times 10^{-3} \times 19.625 \times 5$$

$$= 0.394 \text{ [ft} \cdot \text{lbf)} \dots \text{⑤}$$

From the Effective torque graph on p.1308, select a model where the torque is more than 0.394 [ft·lbf] at 73 psi.

4. Check the kinetic energy

With rubber stopper

According to the given conditions, $\theta=90^\circ$, $t=0.4(\text{s})$ therefore,

$$\omega = \frac{2 \times 1.57}{0.4} = 7.85 \text{ (rad/s)} \cdots \textcircled{1}$$

From ①, the kinetic energy E is

$$E = \frac{1}{2} \times 5.43 \times 10^{-3} \times 7.85^2 = 0.167 \text{ (J)} \cdots \textcircled{2}$$

$0.167 > 0.008$, which means the rubber stopper is not sufficient. Therefore, recalculate a case with shock absorber.

With shock absorber

$$m_1 = \frac{5.43 \times 10^{-3}}{0.018^2} = 16.76 \text{ (kg)} \cdots \textcircled{3}$$

$$m_2 = \frac{2 \times 0.785 \times 0.005}{0.018^3 \times 7.85^2} = 21.84 \text{ (kg)} \cdots \textcircled{4}$$

From ③ and ④,

$$m = 16.76 + 21.84 = 38.60 \text{ (kg)} \cdots \textcircled{5}$$

$$V = 0.018 \times 7.85 = 0.141 \cdots \textcircled{6}$$

From ⑤ and ⑥, find the kinetic energy.

$$E = \frac{1}{2} \times 38.6 \times 0.141^2 = 0.384 \text{ (J)}$$

$0.384 < 0.53$, which means there is no problem in the application with shock absorber.

5. Check the load ratio

[Thrust load]

The total mass is

$$0.034 + 0.127 + 0.981 = 1.142 \text{ (kg)}$$

Therefore,

$$W_s = 1.142 \times 9.8 = 11.192 \text{ (N)} \cdots \textcircled{1}$$

[Radial load]

Since no radial load is applied,

$$W_R = 0 \text{ (N)} \cdots \textcircled{2}$$

[Moment]

The moment M_1 by the rectangular plate is

$$M_1 = (0.034 + 0.127) \times 9.8 \times \left(\frac{0.12}{2} - 0.025 \right) = 0.055 \text{ (N}\cdot\text{m)} \cdots \textcircled{3}$$

The moment M_2 by the cube is

$$M_2 = 0.981 \times 9.8 \times 0.07 = 0.673 \text{ (N}\cdot\text{m)} \cdots \textcircled{4}$$

From ③ and ④, the total moment is

$$M = 0.055 + 0.673 = 0.728 \text{ (N}\cdot\text{m)} \cdots \textcircled{5}$$

From ①, ②, and ⑤, find the load ratio

$$\frac{W_s}{W_{s \text{ MAX}}} + \frac{W_R}{W_{R \text{ MAX}}} + \frac{M}{M_{\text{MAX}}} = \frac{11.192}{120} + \frac{0}{100} + \frac{0.728}{1.3} = 0.65 < 1.0$$

the load ratio is less than 1.0, and satisfactory.

6. Check the unit specifications

Selection of **RAG□8-90-SS2** satisfies both the kinetic energy and load ratio requirements.

4. Check the kinetic energy

With rubber stopper

According to the given conditions, $\theta=90^\circ$, $t=0.4[\text{sec.}]$ therefore,

$$\omega = \frac{2 \times 1.57}{0.4} = 7.85 \text{ [rad/sec.]} \cdots \textcircled{1}$$

From ①, the kinetic energy E' is

$$E' = \frac{1}{2} \times 4.02 \times 10^{-3} \times 7.85^2 = 0.124 \text{ [ft}\cdot\text{lb]} \cdots \textcircled{2}$$

$0.124 > 0.006$, which means the rubber stopper is not sufficient. Therefore, recalculate a case with shock absorber.

With shock absorber

$$w_1 = \frac{4.02 \times 10^{-3} \times 32.2}{\left(\frac{0.71}{12}\right)^2} = 36.98 \text{ [lb]} \cdots \textcircled{3}$$

$$w_2 = \frac{2 \times 0.579 \times \frac{0.2}{12} \times 32.2}{\left(\frac{0.71}{12}\right)^3 \times 7.85^2} = 48.69 \text{ [lb]} \cdots \textcircled{4}$$

From ③ and ④,

$$w = 36.98 + 48.69 = 85.67 \text{ [lb]} \cdots \textcircled{5}$$

$$V' = \frac{0.71}{12} \times 7.85 = 0.464 \cdots \textcircled{6}$$

From ⑤ and ⑥, find the kinetic energy.

$$E' = \frac{85.67 \times 0.464^2}{2 \times 32.2} = 0.286 \text{ [ft}\cdot\text{lb]}$$

$0.286 < 0.39$, which means there is no problem in the application with shock absorber.

5. Check the load ratio

[Thrust load]

The total weight is

$$0.073 + 0.278 + 2.17 = 2.52 \text{ [lb.]}$$

Therefore,

$$W'_s = 2.52 \text{ [lb.]} \cdots \textcircled{1}$$

[Radial load]

Since no radial load is applied,

$$W'_R = 0 \text{ [lb.]} \cdots \textcircled{2}$$

[Moment]

The moment M'_1 by the rectangular plate is

$$M'_1 = (0.073 + 0.278) \times \left(\frac{1}{2} \times \frac{4.72}{12} - \frac{0.98}{12} \right) = 0.040 \text{ [ft}\cdot\text{lb]} \cdots \textcircled{3}$$

The moment M'_2 by the cube is

$$M'_2 = 2.17 \times \frac{2.76}{12} = 0.499 \text{ [ft}\cdot\text{lb]} \cdots \textcircled{4}$$

From ③ and ④, the total moment is

$$M' = 0.040 + 0.499 = 0.539 \text{ [ft}\cdot\text{lb]} \cdots \textcircled{5}$$

From ①, ②, and ⑤, find the load ratio

$$\frac{W'_s}{W'_{s \text{ MAX}}} + \frac{W'_R}{W'_{R \text{ MAX}}} + \frac{M'}{M'_{\text{MAX}}} = \frac{2.52}{27.0} + \frac{0}{22.5} + \frac{0.539}{0.96} = 0.65 < 1.0$$

the load ratio is less than 1.0, and satisfactory.

6. Check the unit specifications

Selection of **RAG□8-90-SS2** satisfies both the kinetic energy and load ratio requirements.

ROTARY ACTUATORS

RAG Series

Symbol

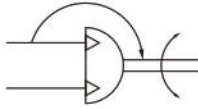

Specifications

Item		Model	RAG□1	RAG□3	RAG□8	RAG□20
Operation type			Double acting single vane type			
Effective torque ^{Note 1}		N·m [ft·lbf]	0.118 [0.087]	0.294 [0.217]	0.785 [0.579]	1.96 [1.45]
Media			Air			
Operating pressure range	MPa [psi.]	With rubber stopper	0.25~0.7 [36.3~102]		0.2~0.7 [29~102]	
		With shock absorber	—	0.32~0.7 [46.4~102]	0.2~0.7 [29~102]	
Proof pressure		MPa [psi.]	1.03 [149]			
Operating temperature range		°C [°F]	5~60 [41~140]			
Cushion		With rubber stopper	Rubber bumper			
		With shock absorber	—	Shock absorber		
Swing angle range		90° type	-5°~95°			
		180° type	-5°~185°			
Swing angle adjustment range ^{Note 2}		90° type	Clockwise rotation end: ±5° referred to 0° position/Counterclockwise rotation end: ±5° referred to 90° position			
		180° type	Clockwise rotation end: ±5° referred to 0° position/Counterclockwise rotation end: ±5° referred to 180° position			
Swing time adjustment range ^{Note 3}		s/90°	0.05~0.25	0.05~0.4	0.05~0.5	0.06~0.6
Allowable energy	J [ft·lbf]	With rubber stopper	0.003 [0.002]	0.005 [0.004]	0.008 [0.006]	0.03 [0.02]
		With shock absorber	—	0.3 [0.22]	0.53 [0.39]	1.14 [0.84]
Allowable thrust load		N [lbf.]	20 [4.5]	60 [13.5]	120 [27.0]	160 [36.0]
Allowable radial load		N [lbf.]	20 [4.5]	80 [18.0]	100 [22.5]	120 [27.0]
Allowable moment		N·m [ft·lbf]	0.4 [0.3]	0.9 [0.7]	1.3 [1.0]	3.5 [2.6]
Deflection accuracy ^{Note 4}	mm[in.]	Table-top surface	0.03 [0.0012]			
		Table-side surface				
Lubrication			Not required (If lubrication is required, use Turbine Oil Class 1 [ISO VG32] or equivalent.)			
Port size			M5×0.8			

Notes: 1. Effective torque is the value when the operating pressure is 0.5 MPa [73 psi.].

2. For the swing end position, see p.1320.

3. The swing time adjustment range is the value by using the rubber stopper option, with no load at air pressure of 0.5 MPa [73 psi.]. (reference value)

4. The deflection accuracy is an actual measurement value, and is not intended to be a guaranteed value.

Shock Absorber Specifications

Item		Model	KSHAR5X5-D	KSHAR5X5-E	KSHAR6X8-F
Applicable model			RAG□3	RAG□8	RAG□20
Maximum absorption		J [ft·lbf]	1.0 [0.74]	2.0 [1.5]	3.0 [2.2]
Absorption stroke		mm [in.]	5 [0.20]		8 [0.31]
Maximum operating frequency		cycle/min	60		30
Maximum impact speed		mm/s[in./sec.]	300 [11.8]		
Angle variation			8° or less		12° or less
Operating temperature range		°C [°F]	0~60 [32~140]		

Caution: Even if the application is within the shock absorber absorption range, follow also within the rotary actuator RAG series swing time adjustment and allowable energy range.

Remarks: 1. Do not loosen or remove the small screw on the rear end of the shock absorber. The oil inside will leak out which will fail the function of the shock absorber.

2. The life of the shock absorber may vary from the rotary actuator RAG series depending on its operating conditions.

Order Codes

RAG [] [] - [] - [] - [] [] []

Number of sensor switches
 1 : With 1 sensor switch
 2 : With 2 sensor switches

Lead wire length
 A : 1000mm [39 in.]
 B : 3000mm [118 in.]

Sensor switch ^{Note 4}
Blank : No sensor switch
ZE101 : Reed switch type, without indicator lamp
ZE102 : Reed switch type, with indicator lamp
ZE201 : Reed switch type, without indicator lamp
ZE202 : Reed switch type, with indicator lamp
ZE135 : 2-lead wires solid state type, with indicator lamp
ZE155 : 3-lead wires solid state type, with indicator lamp
ZE235 : 2-lead wires solid state type, with indicator lamp
ZE255 : 3-lead wires solid state type, with indicator lamp
 ● For details of sensor switches, see p. 1325.

Angle adjustment ^{Note 1}
Blank : With rubber stoppers on both sides
SS2 : With shock absorbers on both sides
SSR : With shock absorber on the right side (Clockwise rotation end side) ^{Note 2}
SSL : With shock absorber on the left side (Counterclockwise rotation end side) ^{Note 2}

Swing angle
 90 : 90°
 180 : 180°

Nominal torque
 1 : 0.118N·m [0.087 ft·lbf]
 3 : 0.294N·m [0.217 ft·lbf]
 8 : 0.785N·m [0.579 ft·lbf]
 20 : 1.96N·m [1.45 ft·lbf]

Magnet ^{Note 4}
Blank : No magnet
S : With magnet

Basic model
 Rotary actuator RAG series

Horizontal lead wire DC5~28V, AC85~115V
 Horizontal lead wire DC10~28V, AC85~115V
 Vertical lead wire ^{Note 3} DC5~28V, AC85~115V
 Vertical lead wire ^{Note 3} DC10~28V, AC85~115V
 Horizontal lead wire DC10~28V
 Horizontal lead wire DC4.5~28V
 Vertical lead wire ^{Note 3} DC10~28V
 Vertical lead wire ^{Note 3} DC4.5~28V

Notes: 1. Nominal torque 1 is not available with shock absorber types (SS2, SSR, or SSL). It is available only with the rubber stopper on both sides type (blank).
 2. The opposite side of the shock absorber (SSR or SSL) comes with the rubber stopper.
 3. In vertical lead wire type, the lead wire protrudes from the sensor switch at right angles. In addition, when the mounting method for RAGS1 or 3 is as shown in Figure 1, use the vertical lead wire type.
 4. When mounting a sensor switch, select the type with a magnet.

Additional Parts

● Rubber stopper

CRK []

- 570 : For RAG [] 1- []
- 588 : For RAG [] 3- [], and RAG [] 8- []
- 589 : For RAG [] 20- []

● Shock absorber

KSHAR []

- 5×5-D : For RAG [] 3- []
- 5×5-E : For RAG [] 8- []
- 6×8-F : For RAG [] 20- []

Remark: The shock absorber or rubber stopper comes as a set consisting of its body and 1 mounting nut.

Mass

Model	Mass	
	No magnet	With magnet
RAG [] 1-90	290 [10.23]	292 [10.30]
RAG [] 1-180	287 [10.12]	288 [10.16]
RAG [] 3-90	451 [15.91]	453 [15.98]
RAG [] 3-90-SS2	451 [15.91]	453 [15.98]
RAG [] 3-90-SSR (L)	451 [15.91]	453 [15.98]
RAG [] 3-180	448 [15.80]	449 [15.84]
RAG [] 3-180-SS2	448 [15.80]	449 [15.84]
RAG [] 3-180-SSR (L)	448 [15.80]	449 [15.84]
RAG [] 8-90	641 [22.61]	643 [22.68]
RAG [] 8-90-SS2	641 [22.61]	643 [22.68]
RAG [] 8-90-SSR (L)	641 [22.61]	643 [22.68]
RAG [] 8-180	638 [22.50]	639 [22.54]
RAG [] 8-180-SS2	638 [22.50]	639 [22.54]
RAG [] 8-180-SSR (L)	638 [22.50]	639 [22.54]
RAG [] 20-90	1026 [36.19]	1028 [36.26]
RAG [] 20-90-SS2	1030 [36.33]	1032 [36.40]
RAG [] 20-90-SSR (L)	1028 [36.26]	1030 [36.33]
RAG [] 20-180	1022 [36.05]	1023 [36.08]
RAG [] 20-180-SS2	1026 [36.19]	1027 [36.23]
RAG [] 20-180-SSR (L)	1024 [36.12]	1025 [36.16]
CRK570	4 [0.14]	
CRK588	10 [0.35]	
CRK589	20 [0.71]	
KSHAR5×5-D	10 [0.35]	
KSHAR5×5-E	10 [0.35]	
KSHAR6×8-F	22 [0.78]	

Sensor switch		g [oz.]
One sensor switch	Lead wire length A	15 [0.53]
	Lead wire length B	35 [1.23]

Inner Construction

RAG□1, 3, 8, 20

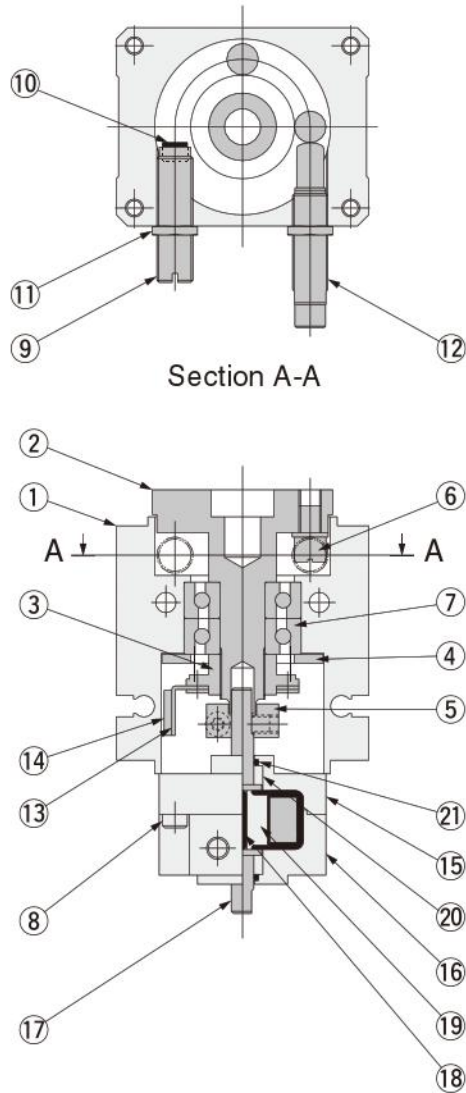

Major Parts and Materials

No.	Parts	Materials	Remarks
①	Body	Aluminum alloy (anodized)	
②	Table	Stainless steel	
③	Nut	Aluminum alloy (anodized)	
④	Cover	Aluminum alloy (anodized)	
⑤	Bracket	Stainless steel	
⑥	Stopper	Special steel	
⑦	Bearing	Steel	RAG□1: Special bearing RAG□3~20: Angular bearing
⑧	Bolt	Stainless steel	
⑨	Adjusting bolt	Steel (nickel plated)	
⑩	Bumper	Synthetic rubber (NBR)	
⑪	Hexagon nut	Mild steel (zinc plated)	
⑫	Shock absorber	—	Applied only for -SS□
⑬	Magnet holder	Aluminum alloy (anodized)	Applied only for RAGS□
⑭	Magnet	Plastic magnet	Applied only for RAGS□
⑮	Body A	Aluminum alloy (anodized)	
⑯	Body B	Aluminum alloy (anodized)	
⑰	Vane axis (shaft portion)	Steel (nitrided)	
	Vane axis (rotor portion)	Molded plastic	
	Vane axis (sealing portion)	Synthetic rubber (NBR)	
⑱	Shoe seal	Synthetic rubber (NBR)	
⑲	Shoe	Molded plastic	
⑳	Bearing	Sintered oil impregnated alloy	
㉑	O-ring	Synthetic rubber (NBR)	

Swing Angle Range and Swing Direction

● 90° type

Remark: The diagrams show when air is supplied to connection port A for the clockwise rotation, and the table has completed the rotation in the clockwise direction (0° position).

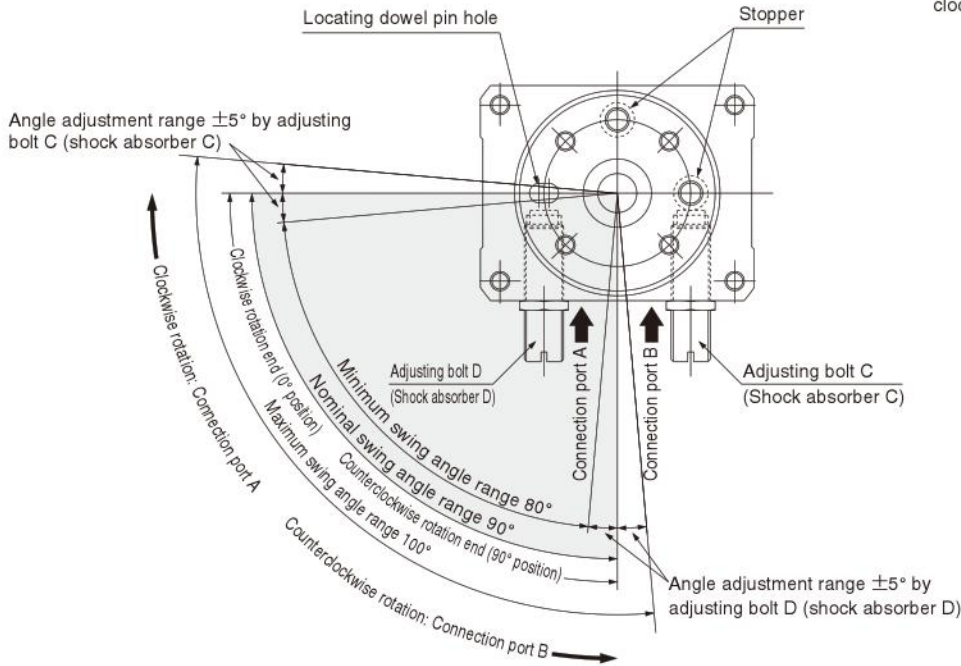

● 180° type

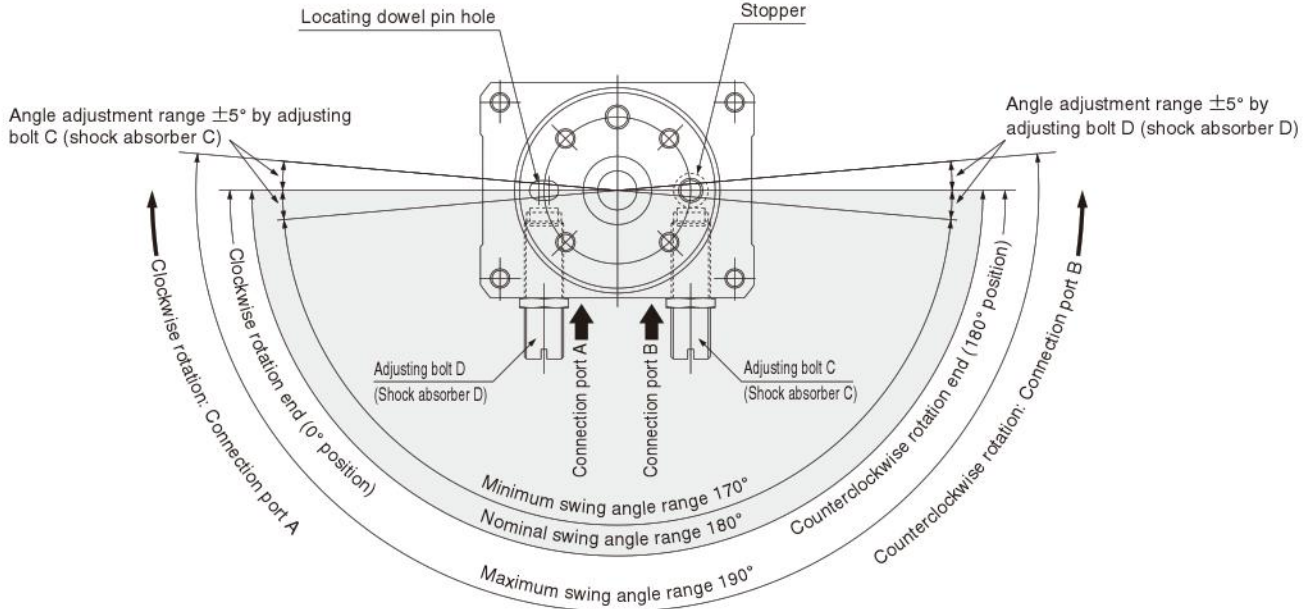

Dimensions mm [in.]

RAG 1-90
RAG 1-180

Remark: The drawings show when air is supplied to the connection port for the clockwise rotation, and the table has completed the rotation in the clockwise direction (0° position).

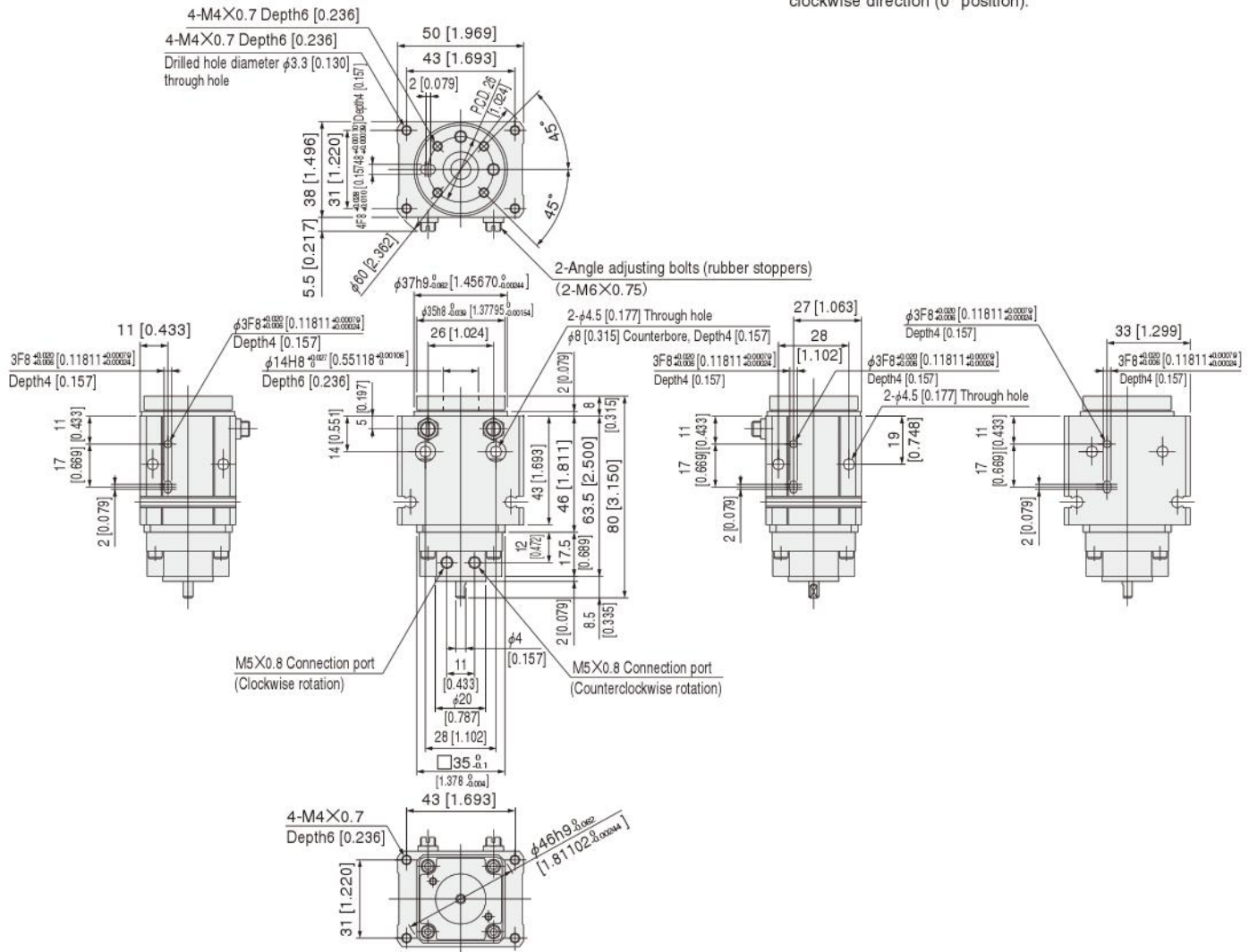

Dimensions of Shock Absorber mm [in.]

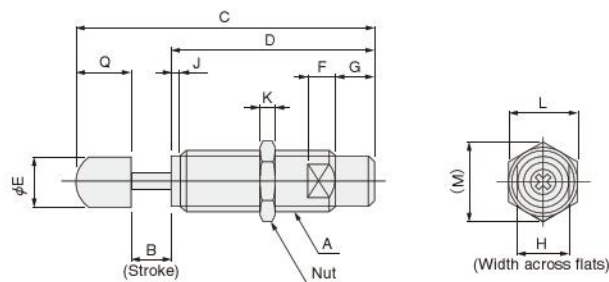

Model	A	B	C	D	E	F	G	H	J	K	L	M	Q
KSHAR5X5-D	M8X0.75	5[0.197]	46[1.811]	31[1.220]	6[0.236]	3[0.118]	5[0.197]	7[0.276]	1.2[0.047]	2[0.079]	10[0.394]	11.5[0.453]	10[0.394]
KSHAR5X5-E	M8X0.75	5[0.197]	46[1.811]	31[1.220]	6[0.236]	3[0.118]	5[0.197]	7[0.276]	1.2[0.047]	2[0.079]	10[0.394]	11.5[0.453]	10[0.394]
KSHAR6X8-F	M10X1	8[0.315]	61[2.402]	45[1.772]	8[0.315]	4[0.157]	5[0.197]	9[0.354]	2[0.079]	3[0.118]	12[0.472]	13.9[0.547]	8[0.315]

Dimensions mm [in.]

RAG □ 3-90
RAG □ 3-180

Remark: The drawings show when air is supplied to the connection port for the clockwise rotation, and the table has completed the rotation in the clockwise direction (0° position).

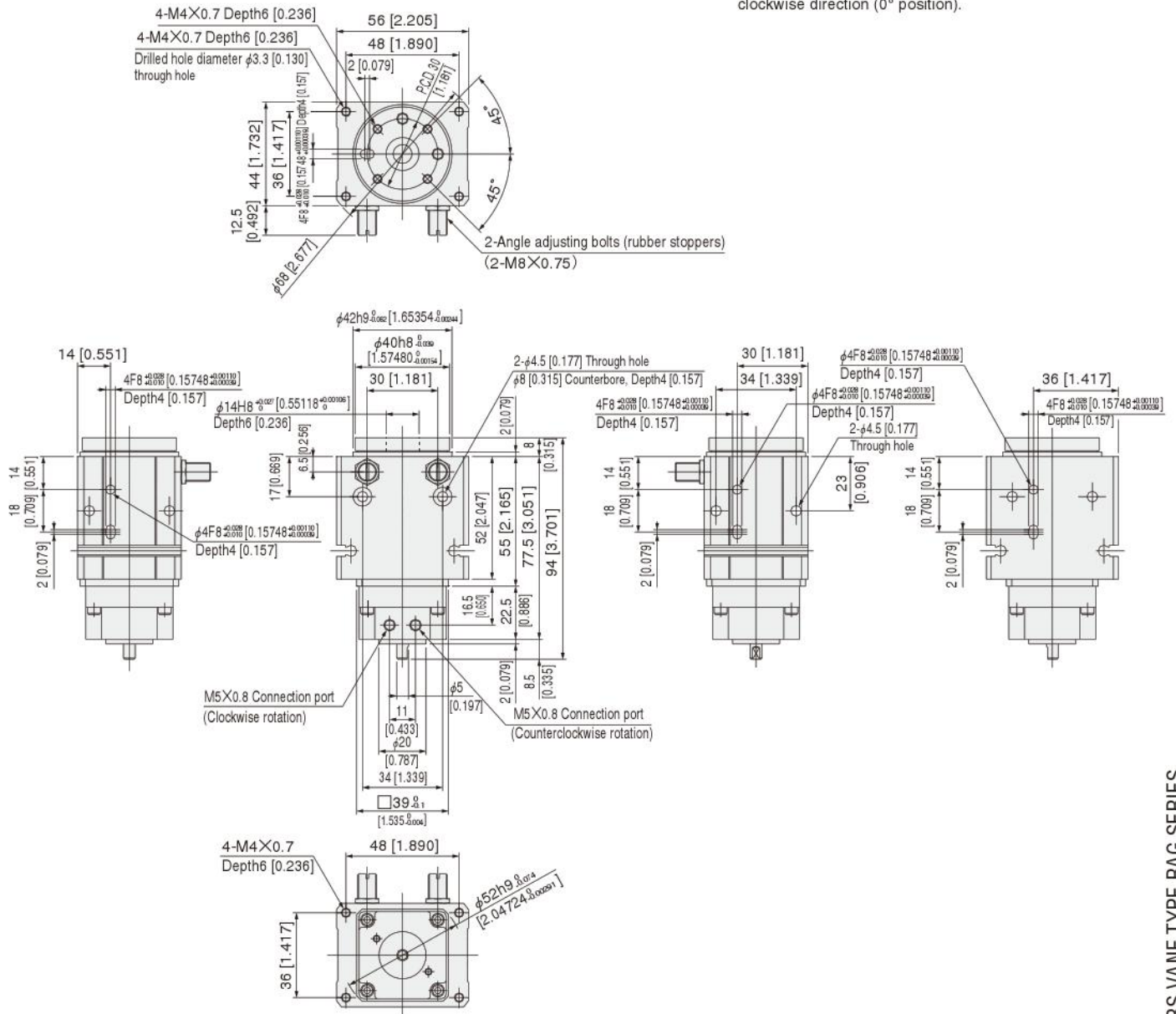

RAG □ 3-90-SS2
RAG □ 3-180-SS2

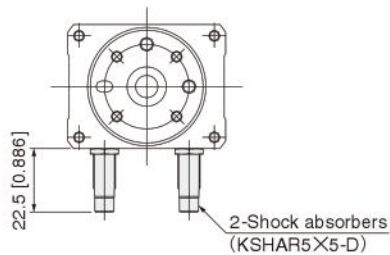

RAG □ 3-90-SSR
RAG □ 3-180-SSR

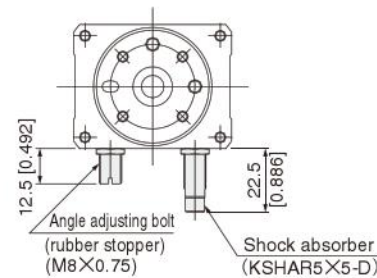

RAG □ 3-90-SSL
RAG □ 3-180-SSL

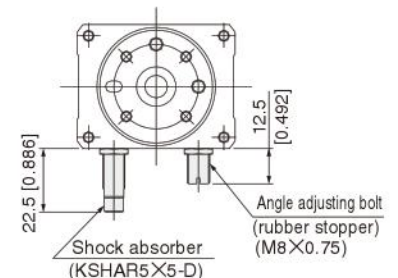

ROTARY ACTUATORS VANE TYPE RAG SERIES

RAG **20-90**
RAG **20-180**

Remark: The drawings show when air is supplied to the connection port for the clockwise rotation, and the table has completed the rotation in the clockwise direction (0° position).

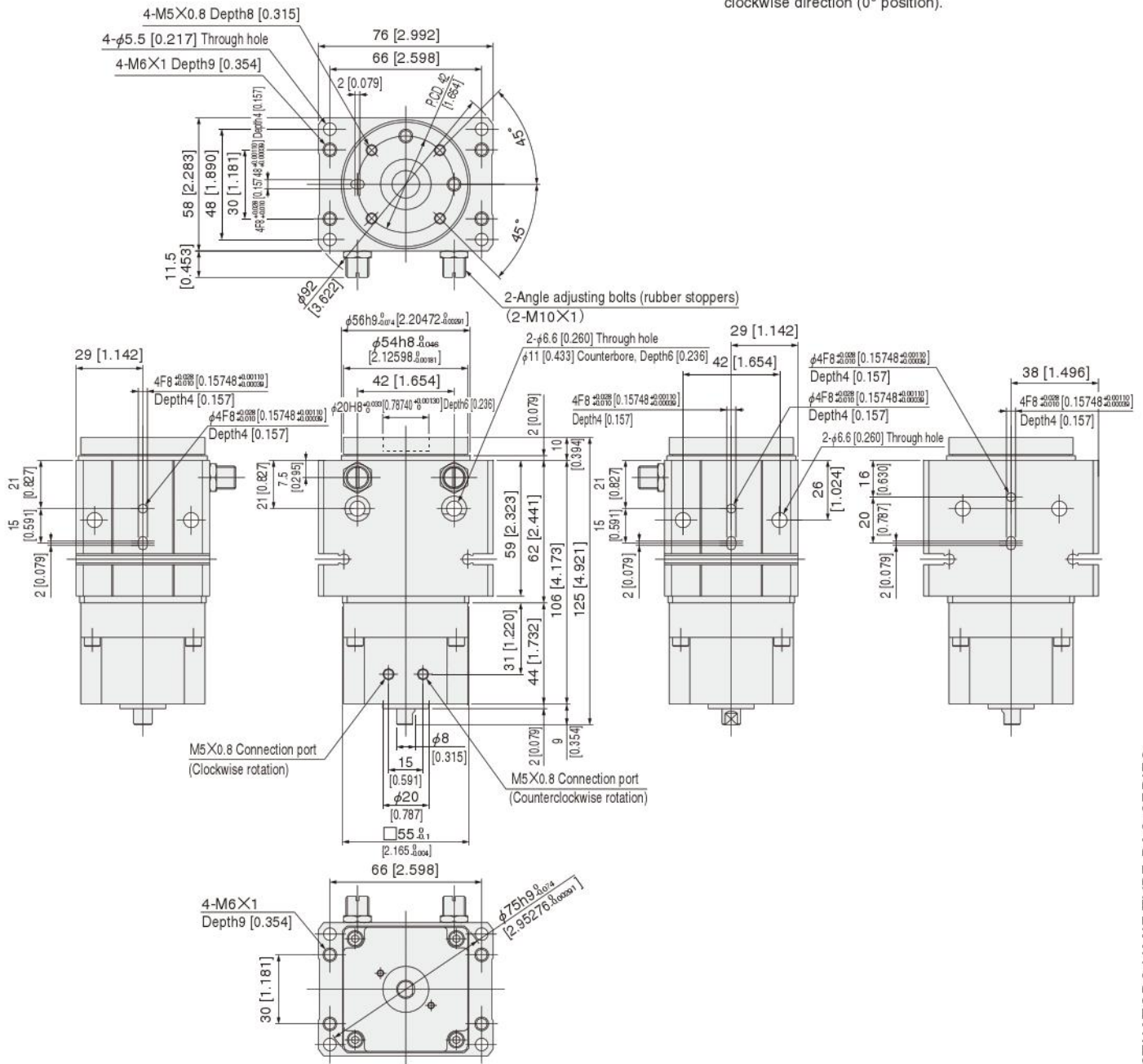

RAG **20-90-SS2**
RAG **20-180-SS2**

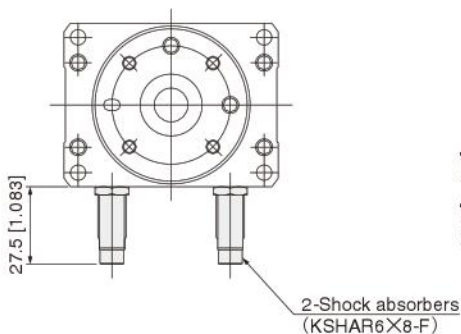

RAG **20-90-SSR**
RAG **20-180-SSR**

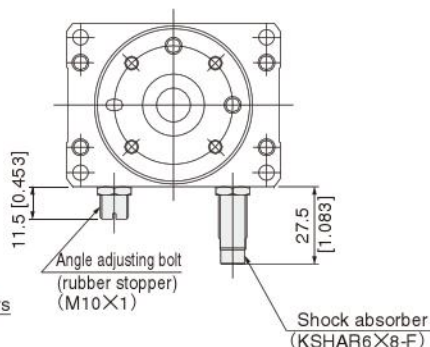

RAG **20-90-SSL**
RAG **20-180-SSL**

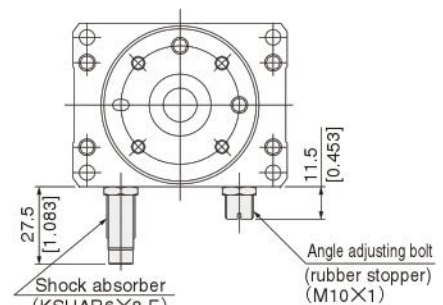

SENSOR SWITCHES

Solid State Type, Reed Switch Type

Order Codes

 - **RAGS**

Lead wire length

- A** — 1000mm [39in.]
- B** — 3000mm [118in.]

Series

RAGS : Rotary actuators RAG series

Sensor switch

ZE135 — Solid state type with indicator lamp	DC10~28V	Horizontal lead wire	ZE155 — Solid state type with indicator lamp	DC4.5~28V	Horizontal lead wire
ZE235 — Solid state type with indicator lamp	DC10~28V	Vertical lead wire	ZE255 — Solid state type with indicator lamp	DC4.5~28V	Vertical lead wire
ZE101 — Reed switch type without indicator lamp	DC5~28V	Horizontal lead wire	ZE102 — Reed switch type with indicator lamp	DC10~28V	Horizontal lead wire
	AC85~115V			AC85~115V	
ZE201 — Reed switch type without indicator lamp	DC5~28V	Vertical lead wire	ZE202 — Reed switch type with indicator lamp	DC10~28V	Vertical lead wire
	AC85~115V			AC85~115V	

●For details of sensor switches, see p.1544.

Moving Sensor Switch

- Loosening the mounting screw allows the sensor switch to be moved along the switch mounting groove on the rotary actuator.
- Tighten the mounting screw with a tightening torque of 0.1~0.2N·m [0.9~1.8in·lbf].

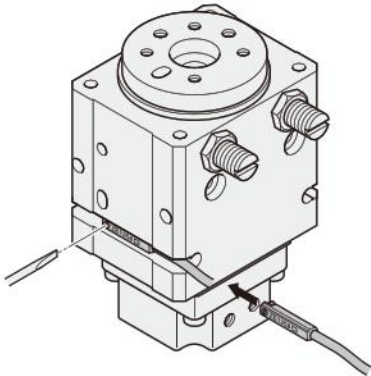

When Mounting the Actuators with Sensor Switches in Close Proximity

When mounting the actuators in close proximity, use them at the values shown in the table below, or larger.

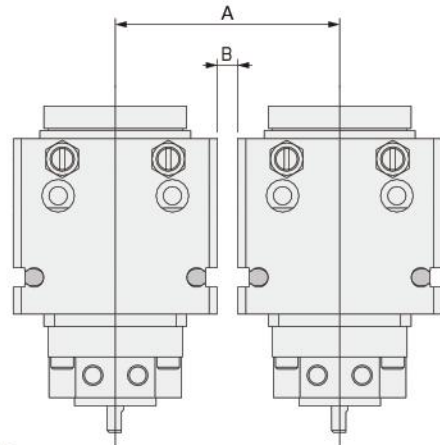

● Solid State Type mm [in.]

Model	A	B
RAGS1	52 [2.047]	2 [0.079]
RAGS3	58 [2.283]	
RAGS8	66 [2.598]	0 [0]
RAGS20	76 [2.992]	

● Reed Switch Type mm [in.]

Model	A	B
RAGS1	50 [1.969]	0 [0]
RAGS3	56 [2.205]	
RAGS8	66 [2.598]	
RAGS20	76 [2.992]	

Sensor Switch Operating Range, Response Differential, and Maximum Sensing Location

- **Operating range: ℓ**
Refers to the range of angles as the magnet moves with the vane to switch ON the sensor, and as the magnet moves further in the same direction until the sensor goes OFF again.
- **Response Differential: C**
Refers to the angle between the point where the sensor is switched ON as the magnet moves with the vane, and the point where the sensor is turned OFF as the magnet moves in the opposite direction.

● Solid state type

Item	Model	RAGS1	RAGS3	RAGS8	RAGS20
Operating range: ℓ		6°~10°	5°~9°	5°~9°	4°~8°
Response differential: C		0.5° or less			
Maximum sensing location ^{Note}		6mm [0.236in.]			

Remark: The above table shows reference values.

Note: This is the length measured from the switch's opposite end side to the lead wire.

● Reed switch type

Item	Model	RAGS1	RAGS3	RAGS8	RAGS20
Operating range: ℓ		13°~20°	12°~18°	11°~17°	8°~15°
Response differential: C		3° or less			
Maximum sensing location ^{Note}		10mm [0.394in.]			

Remark: The above table shows reference values.

Note: This is the length measured from the switch's opposite end side to the lead wire.

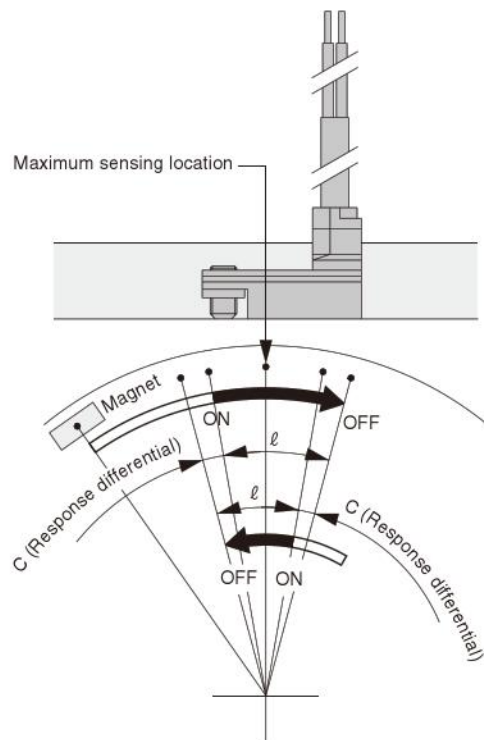

Mounting Location of Swing End Detection Sensor Switch

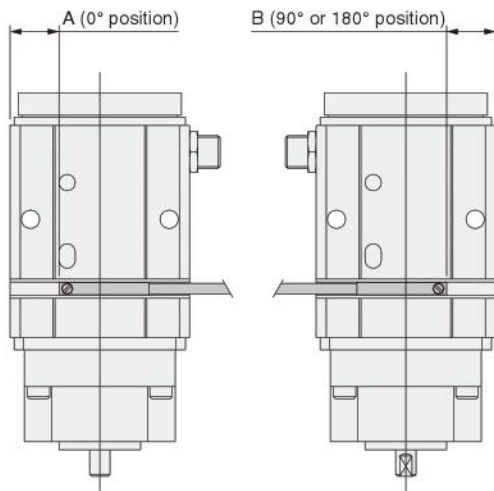

Remark: For the table's 0°, 90°, and 180° positions, see p.1320.

● Solid State Type

mm [in.]

Model	90° and 180° types	
	A	B
RAGS1	13 [0.512]	
RAGS3	16 [0.630]	
RAGS8	19 [0.748]	
RAGS20	23 [0.906]	

● Reed Switch Type

mm [in.]

Model	90° and 180° types	
	A	B
RAGS1	9 [0.354]	
RAGS3	12 [0.472]	
RAGS8	15 [0.591]	
RAGS20	19 [0.748]	