



# Rotary Actuators Piston Type Flat Rotary Actuators



Koganei Brand

All Products Are **RoHS** Compliant



**RAF**

Uses cross roller bearings  
High precision, high rigidity, and lightweight

# Rotary Actuators Piston Type

## Flat Rotary Actuators

 Environmentally friendly **RoHS** compliant products!

**Rotary actuator uses cross roller bearings to achieve high precision and rigidity**

# RAF

 Six types of torque, 1.0, 2.0, 2.5, 3.0, 5.0, and 7.0 N·m [0.74, 1.48, 1.84, 2.21, 3.69, and 5.16 ft·lbf.] <sup>Note</sup> (Nominal) are available. Note: At operating pressure of 0.5 MPa [73 psi]

 Uses cross roller bearings to achieve high precision and rigidity

 Smooth operation from low to high speeds 0.2 to 7.0 s/90°

 Workpiece can be mounted directly to bearing.

 Additional parts for mounting are available. Can handle a variety of mounting formats.

 Thin construction for installation in narrow spaces.

 Large diameter hollow shaft makes piping and wiring easy.

 Equipped with newly developed pressure-resistant shock absorber. Allows smooth control at the end of stroke.

Using cross roller bearings achieves high precision and rigidity

Locating pins (additional parts) make mounting easy

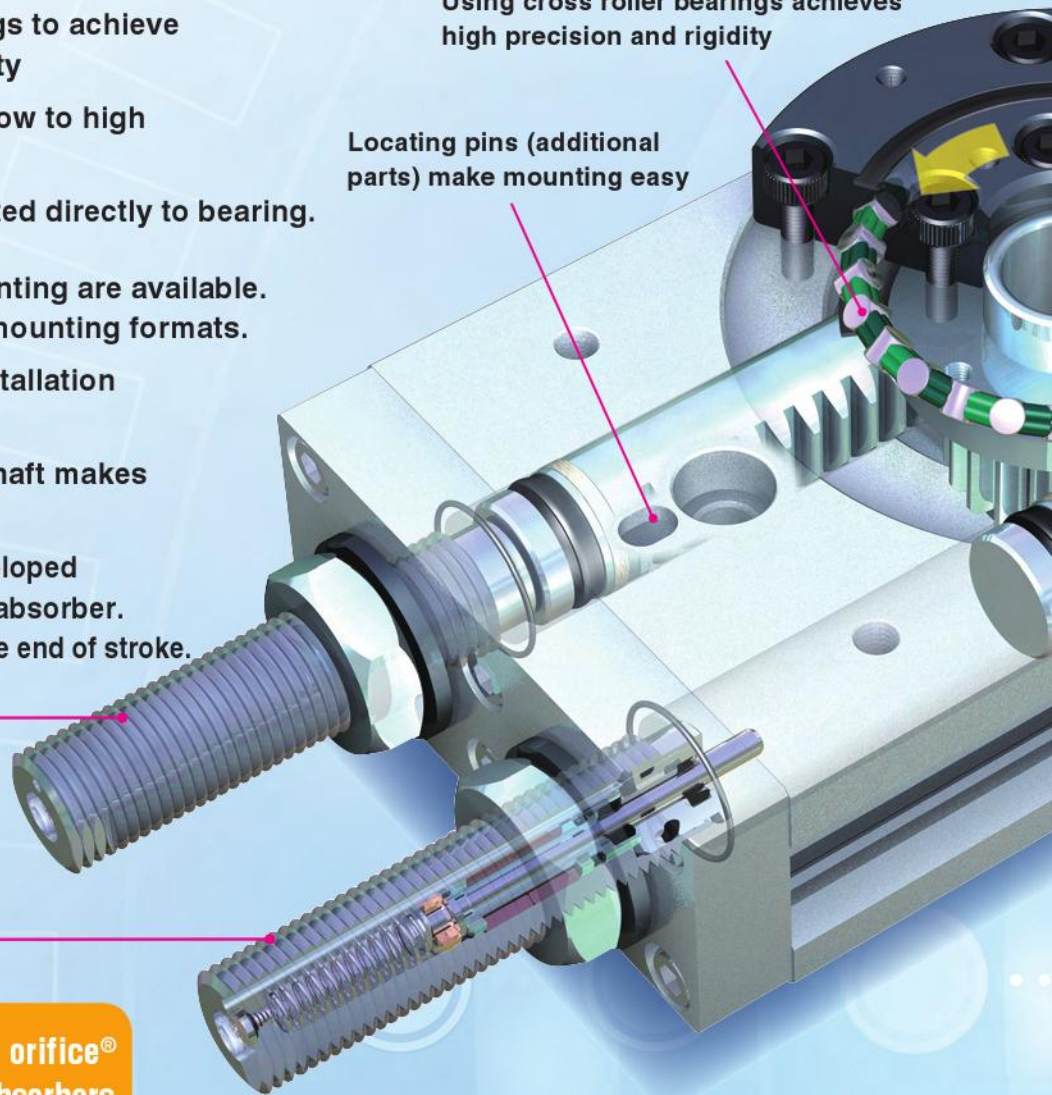

Newly developed

Uses **KSHK series linear orifice®** pressure-resistant shock absorbers

“Linear orifice” is a registered trademark of Koganei Corporation.

### Torque Variation

1.0 N·m [0.74 ft·lbf.]



RAF10-180-□

2.0 N·m [1.48 ft·lbf.]



RAF20-180-□

2.5 N·m [1.84 ft·lbf.]



RAF25-180-□

3.0 N·m [2.21 ft·lbf.]



RAF30-180-□

**CAUTION** Before use, be sure to read the "Safety Precautions" on page 3.

Various mounting methods including body or outer ring mounting

**Large diameter hollow shaft**

Wiring and piping fit easily. Also, spacers (additional parts) makes mounting brackets simple.

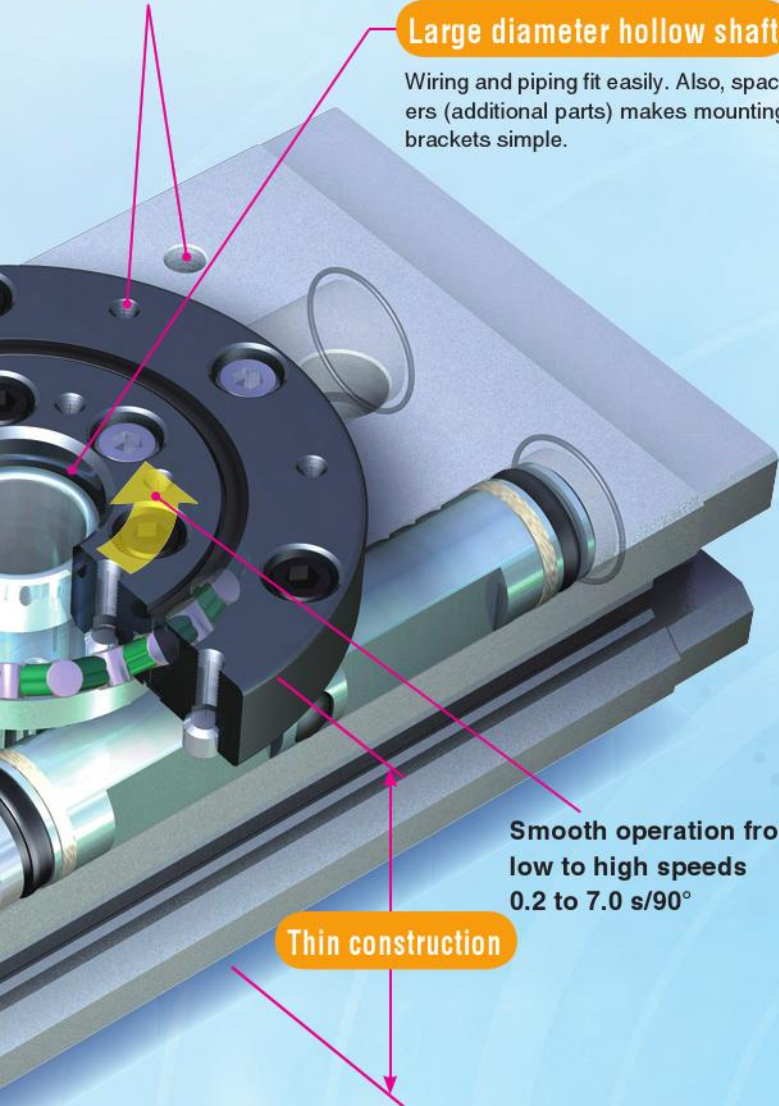

Smooth operation from low to high speeds  
0.2 to 7.0 s/90°

**Thin construction**

**Application example**

●Supply and remove workpieces

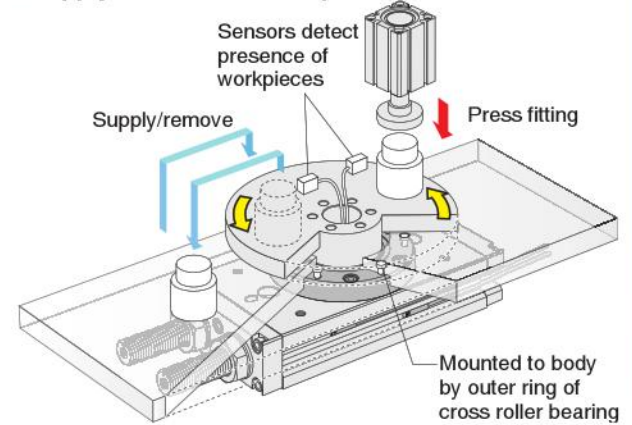

●Manufacturing process for discs etc.

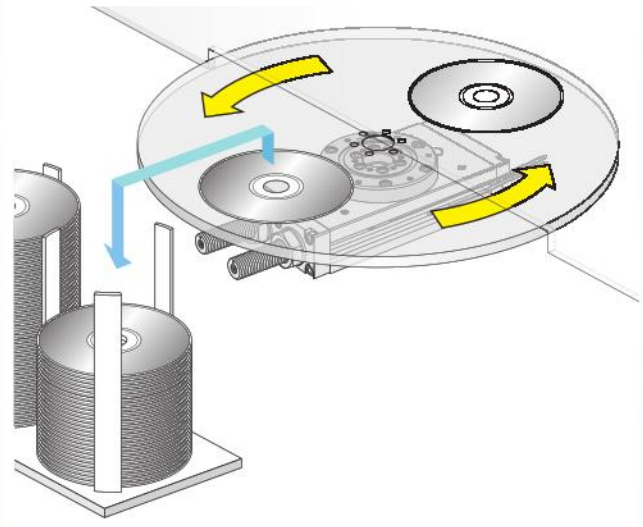

**Additional Parts**

●Locating pin for body  
**P1-RAF** □



●Locating ring for bottom of body  
**R-RAF** □



●Locating pin for cross roller bearing  
**P2-RAF** □



●Spacer for cross roller bearing  
**SP-RAF** □



●Shock absorber  
**KSHK** □ × □-01



5.0 N·m [3.69 ft.·lbf.]

7.0 N·m [5.16 ft.·lbf.]



**RAF50-180**-□





**RAF70-180**-□

**Contents**

|   |    |
|---|----|
| Features .....                              | 1  |
| Safety Precautions .....                    | 3  |
| Handling Instructions and Precautions ..... | 6  |
| Selection .....                             | 12 |
| Specifications .....                        | 21 |
| Order Codes .....                           | 22 |
| Inner Construction .....                    | 23 |
| Dimensions .....                            | 25 |
| Sensor Switches .....                       | 30 |

Before selecting and using the products, please read all the Safety Precautions carefully to ensure proper product use. The Safety Precautions shown below are to help you use the product safely and correctly, and to prevent injury or damage to you, other people, and assets beforehand. Follow the Safety Precautions for: ISO4414 (Pneumatic fluid power—Recommendations for the application of equipment to transmission and control systems), JIS B 8370 (Pneumatic system regulations)

**The directions are ranked according to degree of potential danger or damage: “DANGER!”, “WARNING!”, “CAUTION!”, and “ATTENTION!”**

|  |   |
|--|---|
|  <b>DANGER</b>    | Expresses situations that can be clearly predicted as dangerous. If the noted danger is not avoided, it could result in death or serious injury. It could also result in damage or destruction of assets.                         |
|  <b>WARNING</b>   | Expresses situations that, while not immediately dangerous, could become dangerous. If the noted danger is not avoided, it could result in death or serious injury. It could also result in damage or destruction of assets.      |
|  <b>CAUTION</b>   | Expresses situations that, while not immediately dangerous, could become dangerous. If the noted danger is not avoided, it could result in light or semi-serious injury. It could also result in damage or destruction of assets. |
|  <b>ATTENTION</b> | While there is little chance of injury, this content refers to points that should be observed for appropriate use of the product.   |

- **This product was designed and manufactured as parts for use in General Industrial Machinery.**
- In the selection and handling of the equipment, the system designer or other person with fully adequate knowledge and experience should always read the Safety Precautions, Catalog, Owner’s Manual and other literature before commencing operation. Making mistakes in handling is dangerous.
- After reading the Owner’s Manual, Catalog, etc., always place them where they can be easily available for reference to users of this product.
- If transferring or lending the product to another person, always attach the Owner’s Manual, Catalog, etc., to the product where they are easily visible, to ensure that the new user can use the product safely and properly.
- The danger, warning, and caution items listed under these “Safety Precautions” do not cover all possible cases. Read the Catalog and Owner’s Manual carefully, and always keep safety first.

 **DANGER**

- Do not use the product for the purposes listed below:
  1. Medical equipment related to maintenance or management of human lives or bodies.
  2. Machines or equipment designed for the purpose of moving or transporting people.
  3. Critical safety components in mechanical devices.
 This product has not been planned or designed for purposes that require advanced levels of safety. Using it in this way may result in loss of human life.
- Do not use the product in locations with or near dangerous substances such as flammable or ignitable substances. This product is not explosion-proof. It could ignite or burst into flames.
- When mounting the product and workpiece, always firmly support and secure them in place. Falling, dropping, or abnormal operation etc. of the product, may result in injury.
- Persons who use a pacemaker, etc., should keep a distance of at least one meter [3.28 ft] away from the product. There is a possibility that the pacemaker will malfunction due to the strong magnet built into the product.
- Never attempt to modify the product. It could result in abnormal operation leading to injury, electric shocks, fire, etc.
- Never attempt inappropriate disassembly, assembly, or repair of the product relating to basic construction, or to its performance or functions. It could result in injury, electric shocks, fire, etc.
- Do not splash water on the product. Spraying it with water, washing it, or using it under water could result in malfunction of the product leading to injury, electric shocks, fire, etc.
- While the product is in operation, avoid touching it with your hands or otherwise approaching too close. In addition, do not make any adjustments to the interior or to the attached mechanisms (sensor switch mounting location, disconnection of piping tubes or plugs, etc.). The actuator may move suddenly, possibly resulting in injury.
- When operating the product, always install speed controllers, and gradually loosen the needle valve from a choked state to adjust the increase in speed. Failure to make this adjustment could result in sudden movements, putting human lives at risk.

 **WARNING**

- Do not use the product in excess of its specification range. Such use could result in product breakdowns, function stops, or damage. It could also drastically reduce the product’s operating life.
- Before supplying air or electricity to the device and before starting operation, always conduct a safety check of the area where the machine is operating. Unintentional supply of air or electricity could possibly result in electric shocks, or in injury caused by contact with moving parts.
- Do not touch the terminals and the miscellaneous switches, etc., while the device is turned on. There is a possibility of electric shocks and abnormal operation.
- Do not allow the product to be thrown into fire. The product could explode and/or release toxic gases.
- Do not sit on the product, place your foot on it, or place other objects on it. Dropping the product may result in injury, damage or breakage to the product resulting in abnormal, erratic, or runaway operation, etc.
- When conducting operations, such as maintenance, inspection, repair, or replacement on the product, always turn off the air supply completely and confirm that residual pressure inside the product or in piping connected to the product is zero before proceeding. In particular, be aware that residual air will still be in the air compressor or air storage tank. The actuator could abruptly move if residual air pressure remains inside the piping, causing injury.
- Do not use the actuator for equipment whose purpose is absorbing the shocks and vibrations of mechanical devices. It could break and possibly result in injury or in damage to mechanical devices.
- Avoid scratching the cords for the sensor switch lead wires, etc. Subjecting the cords to scratching, excessive bending, pulling, rolling up, placing them under heavy objects, or squeezing them between two objects may result in current leaks or defective continuity that lead to fires, electric shocks, or abnormal operation.
- Do not subject sensor switches to an external magnetic field during actuator operation. Unintended movements could result in damage to the equipment or in personal injury.

- Use within the recommended load and operating frequency specifications. Attempting to use beyond the recommended load and operating frequency specifications could damage the table, etc., which could result in damage to the equipment or personal injury. It could also drastically reduce the product's operating life.
- Use safety circuits or create system designs that prevent damage to machinery or injury to personnel when the machine is shut down due to an emergency stop or electrical power failure.
- Install relief valves, etc., to ensure that the actuator does not exceed its rated pressure when such pressure is rising due to external forces on the actuator. Excessive operating pressure could lead to a breakdown and damage.
- Do not use the actuator at the beach, in direct sunlight, near mercury lamp, or near equipment that generates ozone. Ozone causes rubber components to deteriorate resulting in reduced performance, or a limitation or stop of functions.
- When the device has been idle for over 48 hours or has been in storage, it is possible that the contacting parts may have become stuck leading to operating delays or sudden movements. Before these initial operations, always run a test to check that operating performance is normal.
- When loosening the shock absorber to adjust the angle, do not loosen it beyond the adjustment range. If it is loosened beyond the adjustment range, it may come off and cause injury.



## CAUTION

- Be sure to wash your hands thoroughly after touching the oil used in the shock absorber or the grease used in the flat rotary actuator. There is a danger that oil or grease transferred from your hands to a cigarette may catch fire and release toxic gases.
- Do not lubricate the flat rotary actuator. Doing so may reduce the operability of the flat rotary actuator, causing the physical properties of the materials used in the shock absorber to change or deteriorate, and may cause a reduction in functionality.
- Do not use in locations that are subject to direct sunlight (ultraviolet rays), dust, salt, iron powder, humidity, or in fluids and/or ambient atmospheres that include organic solvents, phosphate ester type hydraulic oil, sulfur dioxide, chlorine gas, acids, etc. It could lead to early shutdown of some functions or a sudden degradation of performance, and result in a reduced operating life. For information about materials, see Major Parts and Materials.
- When adjusting swing angle range for the shock absorber in the flat rotary actuator, do it at the minimum operating pressure of 0.2 MPa [29 psi]. Also, be sure to read "Swing angle adjustment using shock absorber" on page 8, and when working, be very careful not to extend the shock absorber past its limit.
- When mounting the product, leave room for adequate working space around it. Failure to ensure adequate working space will make it more difficult to conduct daily inspections or maintenance, which could eventually lead to system shutdown or damage to the product.
- Do not bring any magnetic media or memory within one meter [3.28 ft] of the product. There is a possibility that the data on the magnetic media may be destroyed due to the magnetic field of the magnet.
- Do not use the sensor switch in locations subject to large electrical currents or strong magnetic fields. Doing so may cause erratic operation.  
In addition, do not use magnetized materials for the mounting bracket. The magnetic field from these materials could cause erratic operation.
- Do not bring the product too close to magnetic materials. Bringing it near magnetic materials or a strong magnetic field may magnetize the body and table, cause erratic operation of sensor switches, or accretion of iron powder causing failure.
- Never use sensor switches from another company with these products. It could possibly cause error or accidental operation.

- Do not scratch, dent, or deform the actuator by climbing on the product, using it as a scaffold, or placing objects on top of it. It could lead to damaged or broken products that result in operation shutdown or degraded performance.
- Always post an "operations in progress" sign for installations, adjustments, or other operations, to avoid unintentional supplying of air or electrical power, etc. Such accidental activations may cause electrical shocks, or sudden activation of the actuator that could result in physical injury.
- The lead wires, etc., of the sensor switches mounted on the actuators, should not be pulled on, used for lifting, or have heavy objects or excessive loads placed on them. Such action could result in current leaks or defective continuity that lead to fire, electric shocks, or abnormal operation.



## ATTENTION

- When considering the possibility of using this product in situations or environments not specifically noted in the catalog or Owner's Manual, or in applications where safety is an important requirement such as in an airplane facility, combustion equipment, leisure equipment, safety equipment, and other places where human life or assets may be greatly affected, take adequate safety precautions such as the application with enough margins for ratings and performance, or fail-safe measures.  
Be sure to consult us about such applications.
- Always check the catalog and other reference materials for product wiring and piping.
- Use a protective cover, etc., to ensure that operating parts of mechanical devices, etc., are isolated and do not come into direct contact with human bodies.
- Do not control the actuator in a way that could cause workpieces to fall during a power failure.  
Control the actuator so as to prevent the table or workpieces, etc. from falling during a power failure or emergency stop of the mechanical devices.
- When handling the product, wear protective gloves, safety glasses, safety shoes, etc. for protection.
- When the product can no longer be used, or is no longer necessary, dispose of it appropriately, according to the "Waste Management and Public Cleansing Law" or other local governmental rules and regulations, as industrial waste. When the grease in the flat rotary actuator and the special oil inside the shock absorber are incinerated, corrosive and toxic fluorine (HF) is released. Dispose of the oil and grease at a facility that uses a corrosive resistant incinerator. For large amounts, use a registered waste-disposal company.
- Pneumatic equipment can exhibit degraded performance and function over its operating life. Always conduct daily inspections of the pneumatic equipment, and confirm that all requisite system functions are satisfied, to prevent accidents from happening.
- For inquiries about the product, consult your nearest Koganei sales office or Koganei overseas department. The address and telephone number are shown on the back cover of this catalog.



## Other

- Always observe the following items.
  1. When using this product in pneumatic systems, always use genuine KOGANEI parts or compatible parts (recommended parts). When conducting maintenance and repairs, always use genuine KOGANEI parts or compatible parts (recommended parts). Always observe the required methods and procedures.
  2. Never attempt inappropriate disassembly or assembly of the product relating to basic configurations, or its performance or functions.

Koganei is not responsible if these items are not properly observed.



**Design and selection**

**WARNING**

**1. Check the specifications.**

Read the specifications carefully to ensure correct use within the product's specified voltage, current, temperature, and maximum impact. Otherwise it could result in a breakdown or defective operation.

**2. Avoid mounting actuators in close proximity to each other.**

Mounting two or more actuators with sensor switches in close proximity may result in erratic operation of the sensor switches due to magnetic field interference.

**3. Be careful of how long the sensor switch is ON when detecting the position in mid-stroke.**

When setting the sensor switch at an intermediate position of the actuator stroke, be aware that it is possible that if the actuator's speed is too fast during detection of piston travel, the sensor switch's operation time will decrease and the load (programmable controller, etc.) may not activate.

The maximum cylinder speed that can be detected is calculated using the formula below.

$$V \text{ [mm/s]} = \frac{\text{Sensor switch operating range [mm]}}{\text{Time required to activate load [ms]}} \times 1000$$

**4. Keep wiring as short as possible.**

Lead wires for solid state sensor switches should be within 30 m [98 ft.] as stipulated by EN standards. For the reed sensor switch, if the lead wire is too long (10 m [33 ft.] or more), capacitive surges will shorten the operating life of the sensor switch. If long wiring is needed, install the protection circuit mentioned in the catalog.

If the load is inductive or capacitive, also install the protection circuit mentioned in the catalog.

**5. Avoid repeated or excessive bending or pulling of lead wires.**

Applying repeated bending stress or tension force on the lead wires could break them.

**6. Check for current leakage.**

2-lead wire solid state sensor switches produce current leakage to activate their internal circuits and the current passes through the load even when turned-off. Ensure that they satisfy the following inequality:

$$\text{Input off current of programmable controller} > \text{Leakage current}$$

If the above inequality cannot be satisfied, select a 3-lead wire solid state sensor switch instead. Also note that parallel installation of a total of n sensor switches will multiply the amount of current leakage by n times.

**CAUTION**

**1. Check for sensor switch internal voltage drop.**

Series connection of reed sensor switches with indicator lamps or 2-lead wire solid state sensor switches causes increasing internal voltage drop and the load may fail to activate. A total number of n sensor switches will lead to n times the internal voltage drop.

Ensure that the system satisfies the following inequality:

$$\text{Supply voltage} - \text{Internal voltage drop} \times n > \text{Minimum operating voltage for load}$$

In relays with a rated voltage of less than 24VDC, check to see whether the above inequality is satisfied, even in the case of n=1.

If the above inequality cannot be satisfied, select a reed sensor switch without an indicator lamp.

**2. Do not use KOGANEI sensor switches with actuators from another company.**

The sensor switches are designed for use with KOGANEI actuators only. Use with actuators from another company may lead to malfunction.



**Installation and adjustment**

**WARNING**

**1. During actuator operation, do not subject sensor switches to an external magnetic field.**

Unintended movements could result in damage to the equipment or in personal injury.

**CAUTION**

**1. Ensure a safe installation environment for the actuators with sensors.**

Do not use the sensor switch in locations subject to large electrical currents or strong magnetic fields. It could result in erratic operation. In addition, do not use magnetized materials for the mounting bracket. Doing so may cause erratic operation.

**2. Install sensor switches in the center of their operating range.**

Adjust the mounting position of a sensor switch so that the piston stops in the center of its operating range (the range while the sensor is ON). Operations will be unstable if mounted at the end of the operating range (at the boundary near ON and OFF). Also be aware that the operating range will vary with changes in temperature.

**3. Follow the tightening torque guidelines for mounting sensor switches.**

Over-tightening beyond the allowed tightening torque may damage the mounting threads, mounting brackets, sensor switches and other components. However, insufficient tightening torque may cause the sensor switch position to change, resulting in unstable operation. Follow the instructions on p. 33 concerning the tightening torque.

**4. Do not carry the actuator by the sensor switch lead wires.**

After mounting a sensor switch to an actuator, do not grab the lead wires to carry the actuator. It may not only break the lead wires, but it will apply stress to the interior of the sensor switch causing the internal electronic elements to break.

**5. Do not drop or bump sensor switches.**

While handling sensor switches, do not subject them to excessive shock (294.2 m/s<sup>2</sup> [30G]) by hitting, dropping or bumping them. For reed sensor switches, the contact reed may be activated unintentionally, causing it to send or break signals suddenly. This may cause contact interval changes that will affect sensor switch sensitivity and result in erratic operation. Even if the sensor switch case is undamaged, the internal electronic elements of the sensor switch may be damaged resulting in erratic operations.



## Wiring

### DANGER

#### 1. Prevent nearby moving objects from coming into contact with the sensor switches.

When actuators equipped with sensor switches are moving or when moving objects are nearby, do not let them come into contact. In particular, lead wires may become worn or damaged causing unstable operation of the sensor switch. In the worst case, this may result in current leaks or electrical shock.

#### 2. Always turn off the power supply before performing wiring work.

Performing wiring work while the power is on may result in electrical shock. Also, incorrect wiring could damage sensor switches in an instant. Turn on the power only after the wiring work is complete.

### WARNING

#### 1. Check the catalog and other materials to ensure that the sensor switch is wired correctly.

Incorrect wiring may result in abnormal operation.

#### 2. Do not share wiring with power or high voltage lines.

Avoid sharing or wiring parallel to power or high voltage lines. Noise from these lines may cause the sensor switch and control circuit to malfunction.

#### 3. Avoid repeated or excessive bending or pulling of lead wires.

Applying repeated bending stress or tension force on the lead wires could break them.

#### 4. Check the wiring polarity.

Be sure that the wiring connections are correct for sensor switches that specify polarity (+, -, output). Incorrect polarity could result in damage to sensor switches.

### CAUTION

#### 1. Avoid short-circuiting loads.

Turning a sensor switch ON while the load is short-circuited causes an overcurrent that will instantly damage the sensor switch.

An example of a short-circuited load: The sensor switch's output lead wire is directly connected to the power supply.

## Handling Instructions and Precautions



## General Precautions

### Air supply

1. Use air as the medium. For the use of any other medium, consult KOGANEI.
2. Air used for the flat rotary actuator should be clean air that contains no degraded compressor oil, etc. Install an air filter (filtration of 40  $\mu\text{m}$  or less) near the flat rotary actuator or valve to remove dust or accumulated liquid. Also drain the air filter periodically.

### Piping

1. Before installing piping for the flat rotary actuator, always flush the tube completely by blowing compressed air through it. Machining chips, sealing tape, rust and other debris remaining from the piping work may result in air leaks and malfunctions.
2. When screwing pipes or fittings into the flat rotary actuator, use the appropriate tightening torque shown below:

| Connecting thread | Tightening torque N·m [ft.·lbf.] |
|-------------------|----------------------------------|
| M5 × 0.8          | 1.0~1.5 [0.74~1.11]              |
| Rc 1/8            | 7~9 [5.2~6.6]                    |

### Lubrication

Do not lubricate the flat rotary actuator. Doing so may reduce the operability of the flat rotary actuator, causing the physical properties of the materials used in the shock absorber to change or deteriorate, and may cause a reduction in functionality.

### Atmosphere

Protect the actuator with a cover if it is being used where it may be splashed with water or oil.

### When in use

Due to the way the flat rotary actuator is built, a sudden application of compressed air at initial operation may disable speed control resulting in damage to the equipment or the actuator. When applying pressure to flat rotary actuators and equipment that are not pressurized, make sure the table is turned all the way to one side and apply pressure through the piping connection port that does not move the table. See page 24 for information about port location and swing direction.

Or, if the mass moment of inertia of the workpiece is particularly large, use a 5-port, 3-position pressure center solenoid valve to start at the pressure center position. However, do not cause it to hold in a stop location. The location may shift due to air leaks etc.

### Holding torque

When the internal rack contacts and stops against the shock absorber in the flat rotary actuator (double acting double piston type) with shock absorber, the holding torque at the swing end is half of the effective torque.

# Handling Instructions and Precautions



## Mounting

### Body mounting

The flat rotary actuator can be mounted in the following four ways. Tighten mounting screws to a torque within the range limits.

#### ① Mounting using the through holes on the body

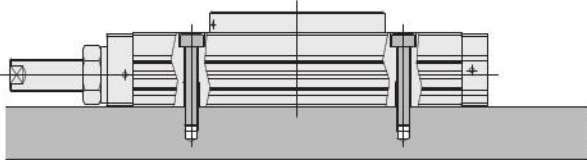

#### ② Mounting by the bottom of the body

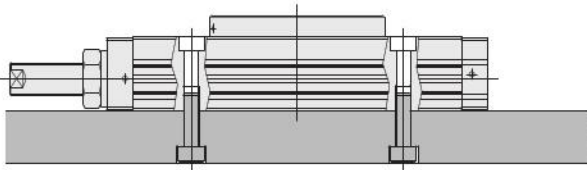

#### ③ Mounting by the top of the body

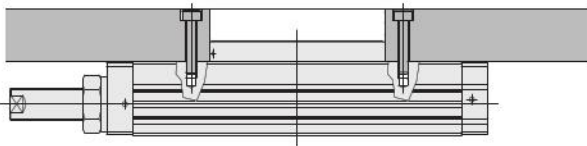

| Model       | ① Mounting using the through holes on the body |  | ② Mounting by the bottom of the body |  | ③ Mounting by the top of the body |  |
|-------------|--|--|--------------------------------------|--|-----------------------------------|--|
|             | Screw size                                     | Maximum tightening torque N·m [ft.-lbf.] | Screw size                           | Maximum tightening torque N·m [ft.-lbf.] | Screw size                        | Maximum tightening torque N·m [ft.-lbf.] |
| RAF10-180-□ | M5 × 0.8                                       | 3.0                                      | M6 × 1                               | 5.2                                      | M4 × 0.7                          | 1.5                                      |
| RAF20-180-□ |  | [2.21]                                   |                                      | [3.84]                                   |                                   | [1.11]                                   |
| RAF25-180-□ | M6 × 1   | 5.2                                      | M8 × 0.25                            | 12.5                                     | M5 × 0.8                          | 3.0                                      |
| RAF30-180-□ |  | [3.84]                                   |                                      | [9.22]                                   |                                   | [2.21]                                   |
| RAF50-180-□ | M8 × 1.25                                      | 12.5                                     | M10 × 1.5                            | 24.5                                     | M6 × 1                            | 5.2                                      |
| RAF70-180-□ |  | [9.22]                                   |                                      | [18.07]                                  |                                   | [3.84]                                   |

#### ④ Mounting using outer ring of cross roller bearing

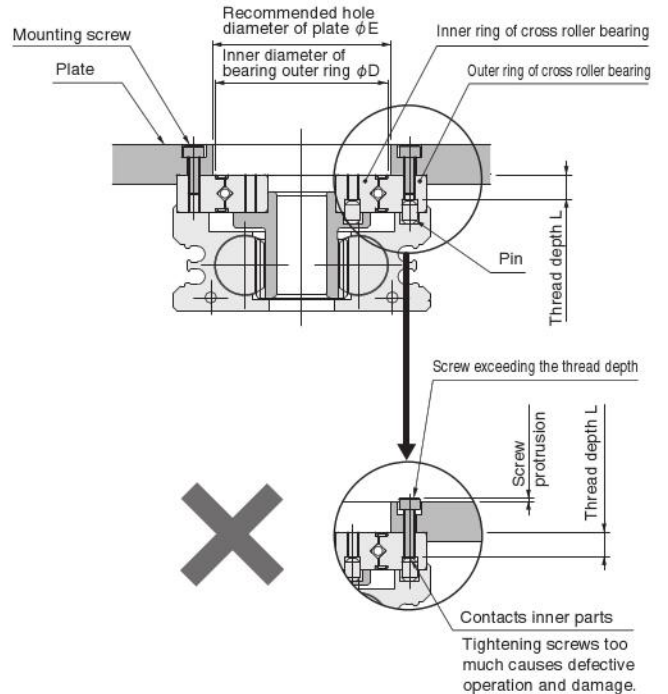

| Model       | Inner diameter of bearing outer ring φD mm [in.] | Recommended hole dia. of plate φE mm [in.] | Screw size | Thread depth L mm [in.] | Maximum tightening torque N·m [ft.-lbf.] |
|-------------|--|--|------------|-------------------------|--|
| RAF10-180-□ | 35.5 [1.398]                                     | 36.0 [1.417]                               | M3 × 0.5   | 6<br>[0.236]            | 1.1 [0.81]                               |
| RAF20-180-□ | 47.0 [1.850]                                     | 47.5 [1.870]                               | M4 × 0.7   | 8<br>[0.315]            | 2.7 [1.99]                               |
| RAF25-180-□ | 51.5 [2.028]                                     | 52.0 [2.047]                               | M5 × 0.8   | 10<br>[0.394]           | 5.4 [3.98]                               |
| RAF30-180-□ | 57.5 [2.264]                                     | 58.0 [2.283]                               | M5 × 0.8   | 11<br>[0.433]           | 5.4 [3.98]                               |

**Note** When using the mounting holes in the outer ring of the cross roller bearings, be sure to use screws that are shorter than the thread depth. Screws that are longer than the thread depth will contact the inner parts, and cause defective operations and damage.

Also, the inner and outer rings of the cross roller bearing are the same height, so there must be a difference in level when mounted and designed so the inner ring does not touch the plate mounted on the outer ring. The recommended dimensions are shown in the table above.

### Handling instructions and precautions for shock absorbers

1. The shock absorber is temporarily tightened before shipping. Before using the actuator be sure to tighten the hexagon nuts and secure them in place.
2. When tightening hexagon nuts, ensure that the tightening torque is within the maximum range. Tightening using excessive force may result in damage.

N·m [ft.·lbf.]

| Model         | Maximum tightening torque |
|---------------|---------------------------|
| RAF10-180-SS2 | 6.5 [4.79]                |
| RAF20-180-SS2 | 6.5 [4.79]                |
| RAF25-180-SS2 | 12.0 [8.85]               |
| RAF30-180-SS2 | 20.0 [14.75]              |
| RAF50-180-SS2 | 25.0 [18.44]              |
| RAF70-180-SS2 | 30.0 [22.13]              |

3. The screw on the rear end of the shock absorber should never be loosened or removed. Oil may leak out of the shock absorber leading to a loss of functionality and resulting in damage to the equipment and accidents.
4. Do not block the air path port on the rear end of the shock absorber. Doing so applies air pressure on the inside of the shock absorber leading to a loss of functionality and resulting in damage to the equipment and accidents.
5. Be sure to insert the **KSHK18×9-01** seal washer in the orientation shown below. Inserting it in the opposite orientation causes air leaks. Also, keep the direction of motion to one direction. Moving it in the opposite direction damages the packing and causes air leaks.

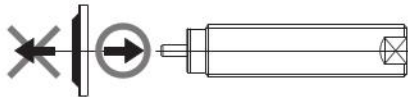

### Replacement procedure for the shock absorber

Before replacement, be sure to completely turn off the air supply, and check that the air pressure in the pipes and equipment is zero. Loosen the hexagon nut for the shock absorber and remove it. Screw in the new shock absorber into the correct position and then tighten it in place with the hexagon nut. Tighten the nut to within the maximum torque. Tightening using excessive torque may result in damage.

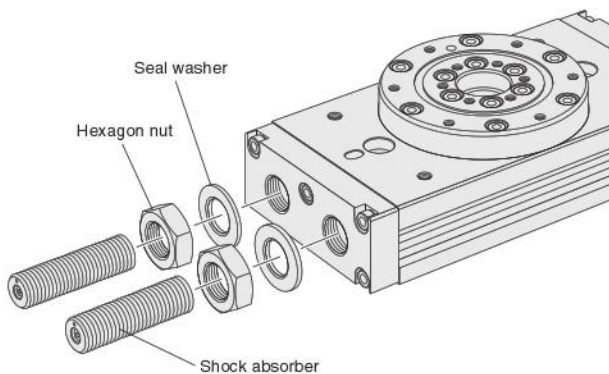

**Note** Replace shock absorbers only with those listed on page 24. Do not replace them with any other shock absorbers.

### Swing angle adjustment using shock absorber

1. The flat rotary actuator uses shock absorbers that can be adjusted in the range of angles shown on page 24. For both clockwise and counterclockwise rotation, screwing in the shock absorber reduces the swing angle. Set the air pressure at the minimum 0.2 MPa [29 psi] when adjusting the swing angle. After completing angle adjustment, tighten the hexagon nuts and secure them in place.
2. Always use a swing angle within the specified range. The dimension L shown in the table below indicates the protrusion of the shock absorber at the maximum swing angle. Do not exceed the L dimension. Using an excessive L dimension will cause the rack inside to touch the side plate, causing defective operations.

| Model         | Dimensions of shock absorber protrusion mm [in.] |
|---------------|--|
| RAF10-180-SS2 | 32.1 [1.264]                                     |
| RAF20-180-SS2 | 38.0 [1.496]                                     |
| RAF25-180-SS2 | 45.8 [1.803]                                     |
| RAF30-180-SS2 | 51.8 [2.039]                                     |
| RAF50-180-SS2 | 53.9 [2.122]                                     |
| RAF70-180-SS2 | 61.5 [2.421]                                     |

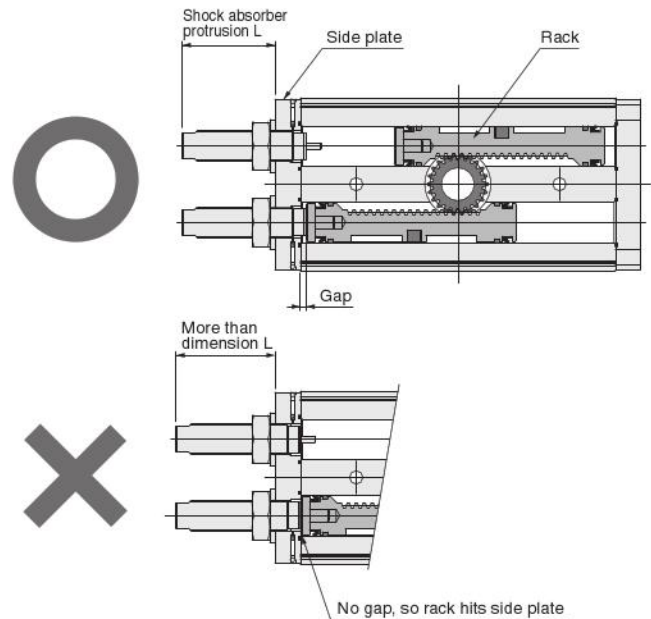

### Precautions when there is no angle adjustment mechanism

When the actuator does not have an angle adjustment mechanism (no shock absorbers), be sure to install an external shock absorber or stopper mechanism so the rack does not hit the plug. Absolutely, do not loosen or remove the plug. Doing so may cause air leaks, defective operation, or the plug may fly out.

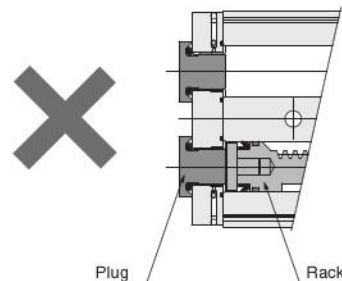

# Handling Instructions and Precautions

## Workpiece mounting

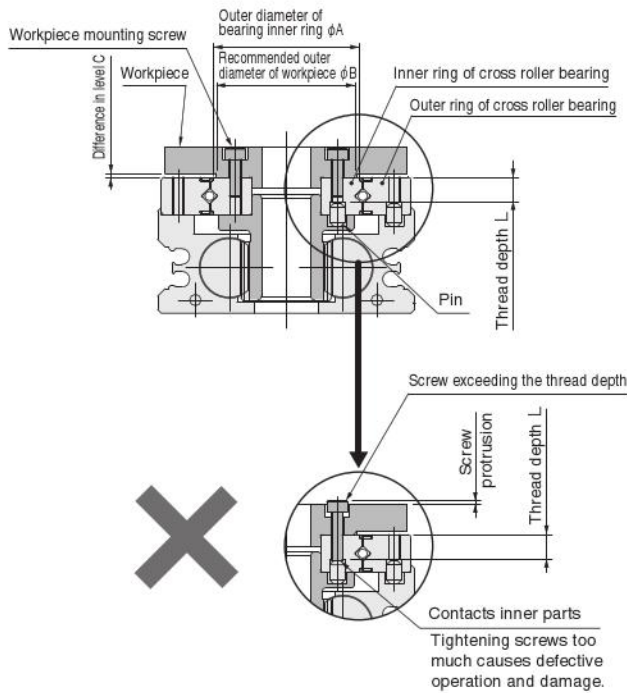

| Model       | Outer diameter of bearing inner ring φA mm [in.] | Recommended outer dia. of workpiece φB mm [in.] | Difference in level C mm [in.] | Screw size | Thread depth L mm [in.] | Maximum tightening torque N·m [ft·lbf.] |
|-------------|--|---|--------------------------------|------------|-------------------------|---|
| RAF10-180-□ | 28.5 [1.122]                                     | 28.0 [1.102]                                    | 0.5<br>[0.020]<br>or over      | M3×0.5     | 6<br>[0.236]            | 1.1 [0.81]                              |
| RAF20-180-□ | 37.0 [1.457]                                     | 36.5 [1.437]                                    |                                |            | 8<br>[0.315]            | 2.7 [1.99]                              |
| RAF25-180-□ | 41.0 [1.614]                                     | 40.5 [1.594]                                    |                                | M4×0.7     | 10<br>[0.394]           | 5.4 [3.98]                              |
| RAF30-180-□ | 47.5 [1.870]                                     | 47.0 [1.850]                                    |                                |            | 11<br>[0.433]           | 5.4 [3.98]                              |
| RAF50-180-□ | 51.0 [2.008]                                     | 50.5 [1.988]                                    |                                | M5×0.8     | 11<br>[0.433]           | 5.4 [3.98]                              |
| RAF70-180-□ | 57.4 [2.260]                                     | 57.0 [2.244]                                    |                                |            | 11<br>[0.433]           | 5.4 [3.98]                              |

When mounting the workpiece on the inner ring of the cross roller bearings, be sure to use screws that are shorter than the thread depth. Screws that are longer than the thread depth will contact the inner parts, and cause defective operations and damage. Also, the inner and outer rings of the cross roller bearing are the same height, so there must be a difference in level when mounted and designed so the inner ring does not touch the plate mounted on the outer ring. The recommended dimensions are shown in the table above.

## Recommended dimensions for locating ring

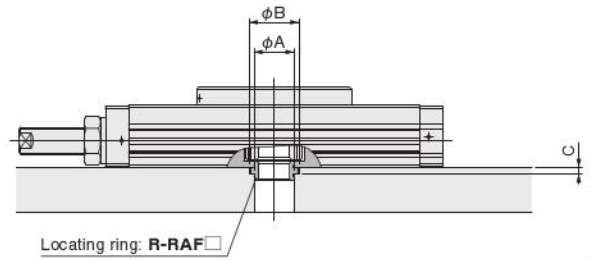

| Model       | Locating ring model | φA  | φB         | C         |
|-------------|---------------------|---|------------|-----------|
| RAF10-180-□ | R-RAF10             | 13H7<br>[0.51181 <sup>+0.00071</sup> <sub>0</sub> ] | 17 [0.669] | 3 [0.118] |
| RAF20-180-□ | R-RAF20             | 17H7<br>[0.66929 <sup>+0.00071</sup> <sub>0</sub> ] | 21 [0.827] |           |
| RAF25-180-□ | R-RAF25             | 19H7<br>[0.74803 <sup>+0.00083</sup> <sub>0</sub> ] | 23 [0.906] |           |
| RAF30-180-□ | R-RAF30             | 23H7<br>[0.90551 <sup>+0.00083</sup> <sub>0</sub> ] | 27 [1.063] |           |
| RAF50-180-□ | R-RAF50             | 26H7<br>[1.02362 <sup>+0.00083</sup> <sub>0</sub> ] | 30 [1.181] |           |
| RAF70-180-□ | R-RAF70             | 26H7<br>[1.02362 <sup>+0.00083</sup> <sub>0</sub> ] | 30 [1.181] |           |

## Air flow rate and air consumption

● Air consumption for 1 cycle cm<sup>3</sup>/cycle [in.<sup>3</sup>/cycle] (ANR)

| Model       | Air pressure MPa [psi] |                   |                   |                   |                   |                   |
|-------------|------------------------|-------------------|-------------------|-------------------|-------------------|-------------------|
|             | 0.2 [29]               | 0.3 [44]          | 0.4 [58]          | 0.5 [73]          | 0.6 [87]          | 0.7 [102]         |
| RAF10-180-□ | 37.1<br>[2.264]        | 49.4<br>[3.015]   | 61.8<br>[3.771]   | 74.1<br>[4.522]   | 86.4<br>[5.272]   | 98.7<br>[6.023]   |
| RAF20-180-□ | 82.5<br>[5.034]        | 109.9<br>[6.707]  | 137.2<br>[8.372]  | 164.6<br>[10.045] | 192.0<br>[11.717] | 219.4<br>[13.389] |
| RAF25-180-□ | 94.0<br>[5.736]        | 125.1<br>[7.634]  | 156.3<br>[9.538]  | 187.5<br>[11.442] | 218.7<br>[13.346] | 249.9<br>[15.250] |
| RAF30-180-□ | 142.5<br>[8.696]       | 189.8<br>[11.582] | 237.1<br>[14.469] | 284.4<br>[17.355] | 331.7<br>[20.242] | 379.0<br>[23.128] |
| RAF50-180-□ | 184.9<br>[11.283]      | 246.3<br>[15.030] | 307.7<br>[18.777] | 369.0<br>[22.518] | 430.4<br>[26.265] | 491.8<br>[30.012] |
| RAF70-180-□ | 255.4<br>[15.586]      | 340.2<br>[20.760] | 424.9<br>[25.929] | 509.7<br>[31.104] | 594.5<br>[36.279] | 679.2<br>[41.447] |

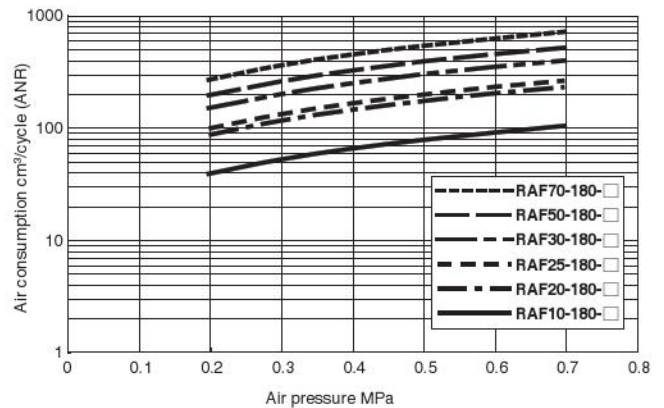

1 cm<sup>3</sup>/cycle = 0.061024 in.<sup>3</sup>/cycle  
1 MPa = 145 psi

**Calculation of air flow rate and air consumption**

The graph on the previous page shows the air consumption during 1 cycle of the flat rotary actuator used in a 180° swing angle. The actual air flow rate and consumption required can be found through the following calculations.

● Finding the air flow rate (for selecting F.R.L., valves, etc.)

$$Q_1 = \frac{\pi D^2}{4} \times L \times \frac{60}{t} \times \frac{P+0.1013}{0.1013} \times 10^{-6}$$

● Finding the air consumption

$$Q_2 = \frac{\pi D^2}{4} \times 2 \times L \times 2 \times n \times \frac{P+0.1013}{0.1013} \times 10^{-6}$$

- Q<sub>1</sub> : Air flow rate required for the cylinder ℓ /min (ANR)
- Q<sub>2</sub> : Cylinder air consumption ℓ /min (ANR)
- D : Cylinder tube inner diameter (bore size) mm
- L : Cylinder stroke mm
- t : Time required for cylinder to travel 1 stroke s
- n : Number of cylinder reciprocations per minute cycles/min
- P : Operating pressure MPa

● Bore size and stroke mm [in.]

| Model       | Cylinder bore size | Cylinder stroke |
|-------------|--------------------|-----------------|
| RAF10-180-□ | 12 [0.472]         | 27.6 [1.087]    |
| RAF20-180-□ | 16 [0.630]         | 34.5 [1.358]    |
| RAF25-180-□ | 16 [0.630]         | 39.3 [1.547]    |
| RAF30-180-□ | 18 [0.709]         | 47.1 [1.854]    |
| RAF50-180-□ | 20 [0.787]         | 49.5 [1.949]    |
| RAF70-180-□ | 22 [0.866]         | 56.5 [2.224]    |

● Static load rating for the cross roller bearing alone

| Item        | Model            | RAF10  | RAF20  | RAF25   | RAF30   | RAF50   | RAF70   |
|-------------|------------------|--------|--------|---------|---------|---------|---------|
| Thrust load |                  | 8700   | 12380  | 20720   | 24090   | 25680   | 47500   |
|             | Ws N [lbf.]      | [1956] | [2783] | [4658]  | [5415]  | [5773]  | [10678] |
| Radial load |                  | 3830   | 5450   | 9120    | 10600   | 11300   | 20900   |
|             | WR N [lbf.]      | [861]  | [1225] | [2050]  | [2383]  | [2540]  | [4698]  |
| Moment      |                  | 65     | 110    | 212     | 272     | 319     | 668     |
|             | M N·m [ft.·lbf.] | [47.9] | [81.1] | [156.4] | [200.6] | [235.3] | [492.7] |

Note: Apply 1/30th or less of the static load rating listed above during use. For details see "Selection" on page 10.

Thrust load

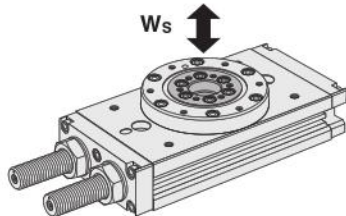

Radial load

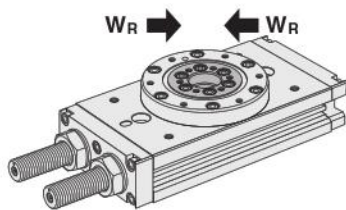

Moment

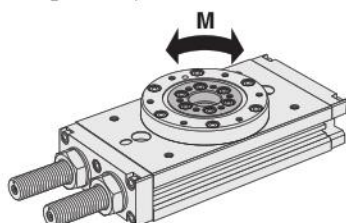

● Effective torque

N·m [ft.·lbf.]

| Model | Air pressure MPa [psi] |                 |                 |                 |                 |                 |                 |                 |                 |                 |                 |
|-------|------------------------|-----------------|-----------------|-----------------|-----------------|-----------------|-----------------|-----------------|-----------------|-----------------|-----------------|
|       | 0.2                    | 0.25            | 0.3             | 0.35            | 0.4             | 0.45            | 0.5             | 0.55            | 0.6             | 0.65            | 0.7             |
| RAF10 | 0.38<br>[0.281]        | 0.48<br>[0.354] | 0.57<br>[0.420] | 0.67<br>[0.494] | 0.77<br>[0.568] | 0.87<br>[0.642] | 0.96<br>[0.708] | 1.06<br>[0.782] | 1.16<br>[0.856] | 1.25<br>[0.922] | 1.35<br>[0.996] |
| RAF20 | 0.85<br>[0.627]        | 1.06<br>[0.782] | 1.28<br>[0.944] | 1.49<br>[1.099] | 1.71<br>[1.261] | 1.92<br>[1.416] | 2.13<br>[1.571] | 2.35<br>[1.733] | 2.56<br>[1.888] | 2.78<br>[2.051] | 2.99<br>[2.205] |
| RAF25 | 0.89<br>[0.656]        | 1.13<br>[0.833] | 1.37<br>[1.011] | 1.62<br>[1.195] | 1.86<br>[1.372] | 2.10<br>[1.549] | 2.34<br>[1.726] | 2.58<br>[1.903] | 2.83<br>[2.087] | 3.07<br>[2.264] | 3.31<br>[2.441] |
| RAF30 | 1.34<br>[0.988]        | 1.71<br>[1.261] | 2.08<br>[1.534] | 2.46<br>[1.814] | 2.83<br>[2.087] | 3.20<br>[2.360] | 3.57<br>[2.633] | 3.94<br>[2.906] | 4.31<br>[3.179] | 4.68<br>[3.452] | 5.06<br>[3.732] |
| RAF50 | 1.80<br>[1.328]        | 2.28<br>[1.682] | 2.77<br>[2.043] | 3.25<br>[2.397] | 3.74<br>[2.759] | 4.22<br>[3.113] | 4.70<br>[3.467] | 5.19<br>[3.828] | 5.67<br>[4.182] | 6.16<br>[4.544] | 6.64<br>[4.898] |
| RAF70 | 2.51<br>[1.851]        | 3.20<br>[2.360] | 3.89<br>[2.869] | 4.58<br>[3.378] | 5.27<br>[3.887] | 5.96<br>[4.396] | 6.65<br>[4.905] | 7.34<br>[5.414] | 8.03<br>[5.923] | 8.72<br>[6.432] | 9.40<br>[6.933] |

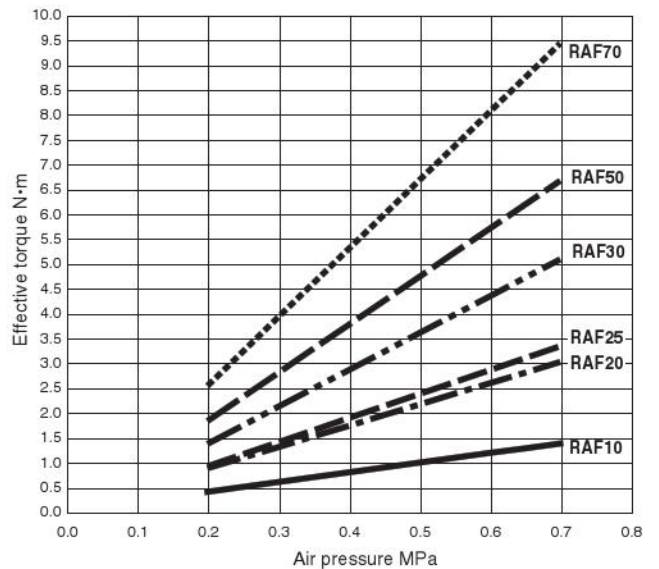

1 N·m = 0.7376 ft.·lbf.

1 MPa = 145 psi

Note: The above values are actual measured values, and are not guaranteed values.

# Handling Instructions and Precautions

- Displacement of inner ring of cross roller bearing due to moment (by load)  
Measured at a position 100 mm [3.94 in.] from the rotation center, with a load applied to a plate mounted on the flat rotary actuator.

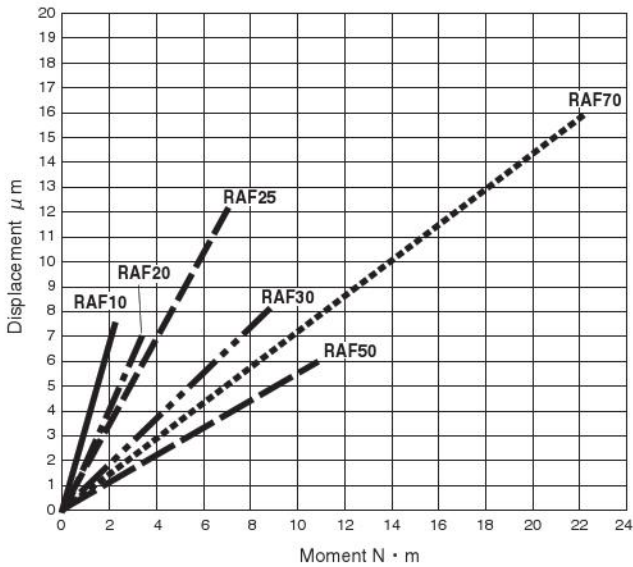
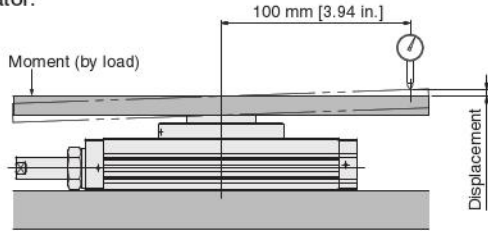

1 N·m = 0.7376 ft·lbf

Note: The above values are actual measured values, and are not guaranteed values.

- Deflection: Displacement of inner ring of cross roller bearing due to 180° swing

| Model       | Deflection of top surface of cross roller bearing |                                    |
|-------------|---|------------------------------------|
|             | Top surface deflection mm [in.]                   | Inside surface deflection mm [in.] |
| RAF10-180-□ | 0.015<br>[0.00059]                                | 0.015<br>[0.00059]                 |
| RAF20-180-□ |   |                                    |
| RAF25-180-□ |   |                                    |
| RAF30-180-□ |   |                                    |
| RAF50-180-□ |   |                                    |
| RAF70-180-□ |   |                                    |

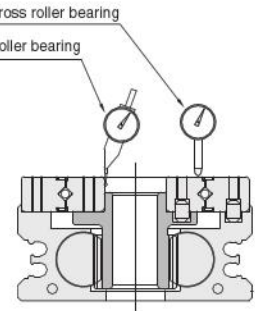

Note: The above values are initial values, and are not guaranteed values.

- Parallelism of cross roller bearing

| Model       | Parallelism A mm [in.]             |
|-------------|------------------------------------|
| RAF10-180-□ | 0.030 <sup>Note</sup><br>[0.00118] |
| RAF20-180-□ |                                    |
| RAF25-180-□ |                                    |
| RAF30-180-□ |                                    |
| RAF50-180-□ |                                    |
| RAF70-180-□ |                                    |

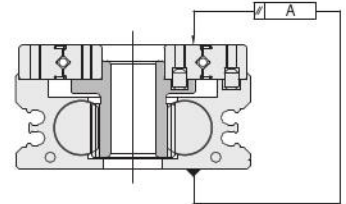

Note: The above values are actual measured values, and are not guaranteed values.

●How to select a model

1. Check operating conditions

- ① Swing angle
- ② Swing time (s)
- ③ Applied pressure (MPa)
- ④ Load shape and materials  
(Reference — Aluminum alloy: Specific gravity =  $2.68 \times 10^3 \text{kg/m}^3$   
Steel: Specific gravity =  $7.85 \times 10^3 \text{kg/m}^3$ )
- ⑤ Mounting direction

2. Check swing time

Check that the swing time in 1-② is within the swing time adjustment range in the specification.  
Swing time: 0.2~7.0 s/90°  
Note: The swing time is obtained with no load at 0.5 MPa.

3. Select torque size

Find the torque  $T_A$  required for rotating the workpiece.

$$T_A = I \dot{\omega} K$$

$$\dot{\omega} = \frac{2\theta}{t^2}$$

$T_A$  : Torque (N·m)  
 $I$  : Mass moment of inertia ( $\text{kg}\cdot\text{m}^2$ )  
 $\dot{\omega}$  : Uniform angular acceleration ( $\text{rad/s}^2$ )  
 $K$  : Marginal coefficient 5  
 $\theta$  : Swing angle (rad)  
     90°→1.57rad  
     180°→3.14rad  
 $t$  : Swing time (s)

Use the applied pressure checked in 1-③ to select an actuator that has the necessary torque  $T_A$  from the effective torque tables or graphs on page 10.

4. Check mass moment of inertia in relation to swing time (when using a shock absorber)

Select an actuator from the “Mass moment of inertia in relation to swing time limits” graphs.

- When swing angle is adjusted to 30° – 90° during use  
Refer to page 19 for the graphs for 90° swing angles.
- When swing angle is adjusted to 91° – 180° during use  
Refer to page 20 for the graphs for 180° swing angles.

●How to select a model

1. Check operating conditions

- ① Swing angle
- ② Swing time [sec.]
- ③ Applied pressure [psi]
- ④ Load shape and materials  
(Reference — Aluminum alloy: Specific gravity = 167 lbf./ft.<sup>3</sup>  
Steel: Specific gravity = 490 lbf./ft.<sup>3</sup>)
- ⑤ Mounting direction

2. Check swing time

Check that the swing time in 1-② is within the swing time adjustment range in the specification.  
Swing time: 0.2~7.0 sec./90°  
Note: The swing time is obtained with no load at 73 psi.

3. Select torque size

Find the torque  $T_A$  required for rotating the workpiece.

$$T_A = I \dot{\omega} K$$

$$\dot{\omega} = \frac{2\theta}{t^2}$$

$T_A$  : Torque [ft·lbf.]  
 $I$  : Mass moment of inertia [ $\text{lbf}\cdot\text{ft}\cdot\text{sec}^2$ ]  
 $\dot{\omega}$  : Uniform angular acceleration [ $\text{rad./sec}^2$ ]  
 $K$  : Marginal coefficient 5  
 $\theta$  : Swing angle [rad.]  
     90°→1.57rad.  
     180°→3.14rad.  
 $t$  : Swing time [sec.]

Use the applied pressure checked in 1-③ to select an actuator that has the necessary torque  $T_A$  from the effective torque tables or graphs on page 10.

4. Check mass moment of inertia in relation to swing time (when using a shock absorber)

Select an actuator from the “Mass moment of inertia in relation to swing time limits” graphs.

- When swing angle is adjusted to 30° – 90° during use  
Refer to page 19 for the graphs for 90° swing angles.
- When swing angle is adjusted to 91° – 180° during use  
Refer to page 20 for the graphs for 180° swing angles.

**5. Check load ratio**

Check that the loads do not exceed 1/30th of the static load rating on each cross roller bearing. Also, check that the total load ratio does not exceed 1/30th of the static load rating on each cross roller bearing. Refer to page 10 for static load ratings for each cross roller bearings.

$$\frac{W_s}{W_{s \text{ MAX}}} \leq \frac{1}{30}$$

$$\frac{W_r}{W_{r \text{ MAX}}} \leq \frac{1}{30}$$

$$\frac{M}{M_{\text{MAX}}} \leq \frac{1}{30}$$

$$\frac{W_s}{W_{s \text{ MAX}}} + \frac{W_r}{W_{r \text{ MAX}}} + \frac{M}{M_{\text{MAX}}} \leq \frac{1}{30}$$

**Precautions for mass moment of inertia in relation to swing time limits**

- 1: The values in the “Mass moment of inertia in relation to swing time limits” graphs are not guaranteed values. The values were measured using a shock absorber with average shock absorbing capacity. Shock absorbing capacity varied within tolerances of shock absorber parts. In addition, shock absorbing capacity and characteristics varied due to operating temperature. This causes the swing time to vary, so allow for leeway for actual usage.
- 2: The times in the “Mass moment of inertia in relation to swing time limits” graphs include shock absorber shock absorbing times.
- 3: Rebound phenomenon may occur even though it is within the range of the “Mass moment of inertia in relation to swing time limits” graphs. Use a speed controller to control the speed so rebound phenomenon does not occur.
- 4: The graphs on page 19 and 20 are based on data for a load (mass moment of inertia) applied to the top of a horizontally mounted actuator.

**5. Check load ratio**

Check that the loads do not exceed 1/30th of the static load rating on each cross roller bearing. Also, check that the total load ratio does not exceed 1/30th of the static load rating on each cross roller bearing. Refer to page 10 for static load ratings for each cross roller bearings.

$$\frac{W_s}{W_{s \text{ MAX}}} \leq \frac{1}{30}$$

$$\frac{W_r}{W_{r \text{ MAX}}} \leq \frac{1}{30}$$

$$\frac{M}{M_{\text{MAX}}} \leq \frac{1}{30}$$

$$\frac{W_s}{W_{s \text{ MAX}}} + \frac{W_r}{W_{r \text{ MAX}}} + \frac{M}{M_{\text{MAX}}} \leq \frac{1}{30}$$

**Precautions for mass moment of inertia in relation to swing time limits**

- 1: The values in the “Mass moment of inertia in relation to swing time limits” graphs are not guaranteed values. The values were measured using a shock absorber with average shock absorbing capacity. Shock absorbing capacity varied within tolerances of shock absorber parts. In addition, shock absorbing capacity and characteristics varied due to operating temperature. This causes the swing time to vary, so allow for leeway for actual usage.
- 2: The times in the “Mass moment of inertia in relation to swing time limits” graphs include shock absorber shock absorbing times.
- 3: Rebound phenomenon may occur even though it is within the range of the “Mass moment of inertia in relation to swing time limits” graphs. Use a speed controller to control the speed so rebound phenomenon does not occur.
- 4: The graphs on page 19 and 20 are based on data for a load (mass moment of inertia) applied to the top of a horizontally mounted actuator.

## ■ Mass moment of inertia calculation diagrams

[When the rotation axis passes through the workpiece]

### ● Disk

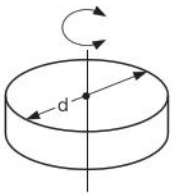

|            |          |   |                  |
|------------|----------|---|------------------|
| ● Diameter | d (m)    | ■ Mass moment of inertia I (kg·m <sup>2</sup> )         | ■ Turning radius |
| ● Mass     | m (kg)   | $I = \frac{md^2}{8}$                                    | $\frac{d^2}{8}$  |
| ● Diameter | d [ft.]  | ■ Mass moment of inertia I' [lbf·ft·sec. <sup>2</sup> ] | ■ Turning radius |
| ● Weight   | w [lbf.] | $I' = \frac{wd^2}{8 \times 32.2}$                       | $\frac{d^2}{8}$  |

Remark: No particular mounting direction.  
For sliding use, see separate materials.

### ● Stepped disk

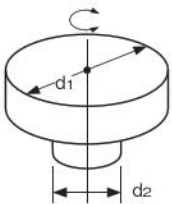

|            |  |   |                           |
|------------|--|---|---------------------------|
| ● Diameter | d <sub>1</sub> (m)                           | ■ Mass moment of inertia I (kg·m <sup>2</sup> )         | ■ Turning radius          |
| ● Mass     | d <sub>2</sub> (m)                           | $I = \frac{1}{8}(m_1d_1^2 + m_2d_2^2)$                  | $\frac{d_1^2 + d_2^2}{8}$ |
|            | d <sub>1</sub> portion m <sub>1</sub> (kg)   |   |                           |
|            | d <sub>2</sub> portion m <sub>2</sub> (kg)   |   |                           |
| ● Diameter | d <sub>1</sub> [ft.]                         | ■ Mass moment of inertia I' [lbf·ft·sec. <sup>2</sup> ] | ■ Turning radius          |
| ● Weight   | d <sub>2</sub> [ft.]                         | $I' = \frac{1}{8 \times 32.2}(w_1d_1^2 + w_2d_2^2)$     | $\frac{d_1^2 + d_2^2}{8}$ |
|            | d <sub>1</sub> portion w <sub>1</sub> [lbf.] |   |                           |
|            | d <sub>2</sub> portion w <sub>2</sub> [lbf.] |   |                           |

Remark: The d<sub>2</sub> portion can be negligible when it is much smaller than the d<sub>1</sub> portion.

### ● Bar (rotation center is at the edge)

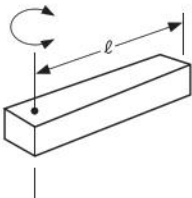

|              |          |   |                  |
|--------------|----------|---|------------------|
| ● Bar length | l (m)    | ■ Mass moment of inertia I (kg·m <sup>2</sup> )         | ■ Turning radius |
| ● Mass       | m (kg)   | $I = \frac{ml^2}{3}$                                    | $\frac{l^2}{3}$  |
| ● Bar length | l [ft.]  | ■ Mass moment of inertia I' [lbf·ft·sec. <sup>2</sup> ] | ■ Turning radius |
| ● Weight     | w [lbf.] | $I' = \frac{wl^2}{3 \times 32.2}$                       | $\frac{l^2}{3}$  |

Remark: Mounting direction is horizontal.  
If the mounting direction is vertical, the swing time will change.

### ● Slender rod

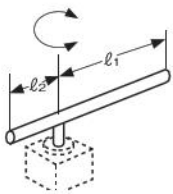

|              |                       |  |                           |
|--------------|-----------------------|--|---------------------------|
| ● Bar length | l <sub>1</sub> (m)    | ■ Mass moment of inertia I (kg·m <sup>2</sup> )                                      | ■ Turning radius          |
| ● Mass       | l <sub>2</sub> (m)    | $I = \frac{m_1 \cdot l_1^2}{3} + \frac{m_2 \cdot l_2^2}{3}$                          | $\frac{l_1^2 + l_2^2}{3}$ |
|              | m <sub>1</sub> (kg)   |  |                           |
|              | m <sub>2</sub> (kg)   |  |                           |
| ● Bar length | l <sub>1</sub> [ft.]  | ■ Mass moment of inertia I' [lbf·ft·sec. <sup>2</sup> ]                              | ■ Turning radius          |
| ● Weight     | l <sub>2</sub> [ft.]  | $I' = \frac{w_1 \cdot l_1^2}{3 \times 32.2} + \frac{w_2 \cdot l_2^2}{3 \times 32.2}$ | $\frac{l_1^2 + l_2^2}{3}$ |
|              | w <sub>1</sub> [lbf.] |  |                           |
|              | w <sub>2</sub> [lbf.] |  |                           |

Remark: Mounting direction is horizontal.  
If the mounting direction is vertical, the swing time will change.

### ● Bar (rotation center is through the center of gravity)

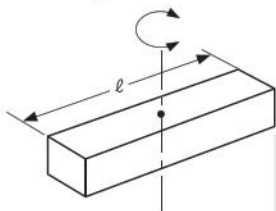

|              |          |   |                  |
|--------------|----------|---|------------------|
| ● Bar length | l (m)    | ■ Mass moment of inertia I (kg·m <sup>2</sup> )         | ■ Turning radius |
| ● Mass       | m (kg)   | $I = \frac{ml^2}{12}$                                   | $\frac{l^2}{12}$ |
| ● Bar length | l [ft.]  | ■ Mass moment of inertia I' [lbf·ft·sec. <sup>2</sup> ] | ■ Turning radius |
| ● Weight     | w [lbf.] | $I' = \frac{wl^2}{12 \times 32.2}$                      | $\frac{l^2}{12}$ |

Remark: No particular mounting direction.

●Thin rectangular plate (rectangular solid)

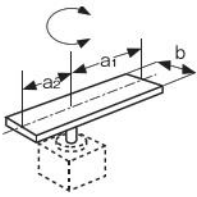

|                  |                       |  |  |
|------------------|-----------------------|--|--|
| ●Length of plate | a <sub>1</sub> (m)    | ■Mass moment of inertia I (kg·m <sup>2</sup> )   | ■Turning radius                              |
|                  | a <sub>2</sub> (m)    | $I = \frac{m_1}{12}(4a_1^2 + b^2) + \frac{m_2}{12}(4a_2^2 + b^2)$                          | $\frac{(4a_1^2 + b^2) + (4a_2^2 + b^2)}{12}$ |
| ●Length of side  | b (m)                 |  |  |
| ●Mass            | m <sub>1</sub> (kg)   |  |  |
|                  | m <sub>2</sub> (kg)   |  |  |
| ●Length of plate | a <sub>1</sub> [ft.]  | ■Mass moment of inertia I' [lbf·ft·sec. <sup>2</sup> ]                                     | ■Turning radius                              |
|                  | a <sub>2</sub> [ft.]  | $I' = \frac{m_1}{12 \times 32.2}(4a_1^2 + b^2) + \frac{m_2}{12 \times 32.2}(4a_2^2 + b^2)$ | $\frac{(4a_1^2 + b^2) + (4a_2^2 + b^2)}{12}$ |
| ●Length of side  | b [ft.]               |  |  |
| ●Weight          | w <sub>1</sub> [lbf.] |  |  |
|                  | w <sub>2</sub> [lbf.] |  |  |

Remark: Mounting direction is horizontal.  
If the mounting direction is vertical, the swing time will change.

●Rectangular solid

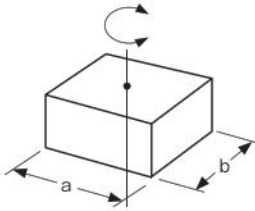

|                 |          |  |                        |
|-----------------|----------|--|------------------------|
| ●Length of side | a (m)    | ■Mass moment of inertia I (kg·m <sup>2</sup> )         | ■Turning radius        |
|                 | b (m)    | $I = \frac{m}{12}(a^2 + b^2)$                          | $\frac{a^2 + b^2}{12}$ |
| ●Mass           | m (kg)   |  |                        |
| ●Length of side | a [ft.]  | ■Mass moment of inertia I' [lbf·ft·sec. <sup>2</sup> ] | ■Turning radius        |
|                 | b [ft.]  | $I' = \frac{m}{12 \times 32.2}(a^2 + b^2)$             | $\frac{a^2 + b^2}{12}$ |
| ●Weight         | w [lbf.] |  |                        |

Remark: No particular mounting direction.  
For sliding use, see separate materials.

●Concentrated load

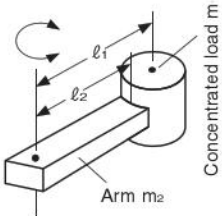

|   |                       |   |
|---|-----------------------|---|
| ●Shape of concentrated load                         |                       | ■Mass moment of inertia I (kg·m <sup>2</sup> )  |
| ●Distance to center of gravity of concentrated load | l <sub>1</sub> (m)    | $I = m_1 k^2 + m_1 l_1^2 + \frac{m_2 l_2^2}{3}$   |
| ●Length of arm                                      | l <sub>2</sub> (m)    |   |
| ●Mass of concentrated load                          | m <sub>1</sub> (kg)   | Rotating radius: k <sup>2</sup> is calculated in relation to shape of the concentrated load.  |
| ●Mass of arm  | m <sub>2</sub> (kg)   | Remark: Mounting direction is horizontal.<br>When m <sub>2</sub> is much smaller than m <sub>1</sub> , calculate as m <sub>2</sub> = 0. |
| ●Shape of concentrated load                         |                       | ■Mass moment of inertia I' [lbf·ft·sec. <sup>2</sup> ]  |
| ●Distance to center of gravity of concentrated load | l <sub>1</sub> [ft.]  | $I' = \frac{w_1 k^2}{32.2} + \frac{w_1 l_1^2}{32.2} + \frac{w_2 \times l_2^2}{32.2 \times 3}$   |
| ●Length of arm                                      | l <sub>2</sub> [ft.]  |   |
| ●Mass of concentrated load                          | w <sub>1</sub> [lbf.] | Rotating radius: k <sup>2</sup> is calculated in relation to shape of the concentrated load.  |
| ●Mass of arm  | w <sub>2</sub> [lbf.] | Remark: Mounting direction is horizontal.<br>When w <sub>2</sub> is much smaller than w <sub>1</sub> , calculate as w <sub>2</sub> = 0. |

●Gear Equation for calculating the load J<sub>L</sub> with respect to rotary actuator axis when transmitted by gears

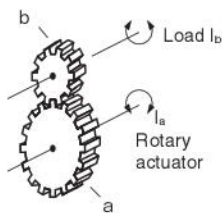

|                         |         |   |
|-------------------------|---------|---|
| ●Gear Rotary side       | a       | ■Mass moment of inertia I (kg·m <sup>2</sup> )                      |
| Load side               | b       | Mass moment of inertia of load with respect to rotary actuator axis |
| ●Inertia moment of load | N·m     | $I_a = \left(\frac{a}{b}\right)^2 I_b$                              |
| ●Gear Rotary side       | a       | ■Mass moment of inertia I' [lbf·ft·sec. <sup>2</sup> ]              |
| Load side               | b       | Mass moment of inertia of load with respect to rotary actuator axis |
| ●Inertia moment of load | ft·lbf. | $I'_a = \left(\frac{a}{b}\right)^2 I'_b$                            |

Remark: If the shapes of the gears are too large, the mass moment of inertia of the gears must be also taken into consideration.

[When the rotation axis is offset from the workpiece]

●Rectangular parallelepiped

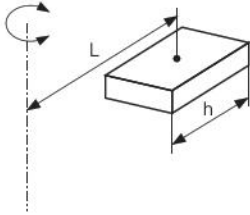

- Length of side h (m)
- Distance from rotation axis to the center of load L (m)
- Mass m (kg)

■Mass moment of inertia I (kg·m<sup>2</sup>)

$$I = \frac{mh^2}{12} + mL^2$$

- Length of side h [ft.]
- Distance from rotation axis to the center of load L [ft.]
- Weight w [lbf.]

■Mass moment of inertia I' [lbf·ft·sec.<sup>2</sup>]

$$I' = \frac{wh^2}{32.2 \times 12} + \frac{wL^2}{32.2}$$

Remark: Same for cube.

●Hollow rectangular parallelepiped

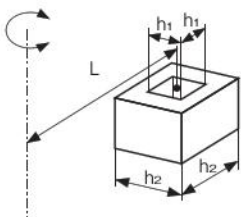

- Length of side h<sub>1</sub> (m)
- h<sub>2</sub> (m)
- Distance from rotation axis to the center of load L (m)
- Mass m (kg)

■Mass moment of inertia I (kg·m<sup>2</sup>)

$$I = \frac{m}{12} (h_2^2 + h_1^2) + mL^2$$

- Length of side h<sub>1</sub> [ft.]
- h<sub>2</sub> [ft.]
- Distance from rotation axis to the center of load L [ft.]
- Weight w [lbf.]

■Mass moment of inertia I' [lbf·ft·sec.<sup>2</sup>]

$$I' = \frac{w(h_2^2 + h_1^2)}{32.2 \times 12} + \frac{wL^2}{32.2}$$

Remark: Cross section is square only.

●Circular cylinder

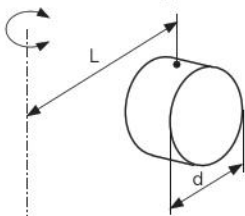

- Diameter d (m)
- Distance from rotation axis to the center of load L (m)
- Mass m (kg)

■Mass moment of inertia I (kg·m<sup>2</sup>)

$$I = \frac{md^2}{16} + mL^2$$

- Diameter d [ft.]
- Distance from rotation axis to the center of load L [ft.]
- Weight w [lbf.]

■Mass moment of inertia I' [lbf·ft·sec.<sup>2</sup>]

$$I' = \frac{wd^2}{32.2 \times 16} + \frac{wL^2}{32.2}$$

●Hollow circular cylinder

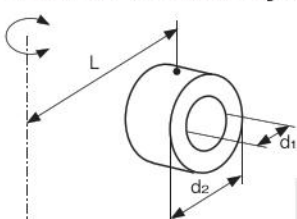

- Diameter d<sub>1</sub> (m)
- d<sub>2</sub> (m)
- Distance from rotation axis to the center of load L (m)
- Mass m (kg)

■Mass moment of inertia I (kg·m<sup>2</sup>)

$$I = \frac{m}{16} (d_2^2 + d_1^2) + mL^2$$

- Diameter d<sub>1</sub> [ft.]
- d<sub>2</sub> [ft.]
- Distance from rotation axis to the center of load L [ft.]
- Weight w [lbf.]

■Mass moment of inertia I' [lbf·ft·sec.<sup>2</sup>]

$$I' = \frac{w(d_2^2 + d_1^2)}{32.2 \times 16} + \frac{wL^2}{32.2}$$

●Calculation example

1. Check operating conditions

- ① Swing angle  $\theta$ : 3.14 (rad)←180°
- ② Swing time t: 1.5 (s)
- ③ Applied pressure P: 0.5 (MPa)
- ④ Load shape Disk  
Diameter d: 0.2 (m)  
Mass m: 10 (kg)

2. Check swing time

The swing time is expressed as 0.75 s/90° for 90°, which is within the range of 0.2 - 7.0 s/90°, and satisfactory.

3. Select by the torque

Find the mass moment of inertia I.

$$I = \frac{md^2}{8} = \frac{10 \times 0.2^2}{8}$$

$$= 0.05 \text{ (kg} \cdot \text{m}^2) \dots \text{①}$$

Find the uniform angular acceleration  $\dot{\omega}$ .

$$\dot{\omega} = \frac{2\theta}{t^2} = \frac{2 \times 3.14}{1.5^2}$$

$$= 2.79 \text{ (rad/s}^2) \dots \text{②}$$

From ① and ②, the necessary torque  $T_A$  is

$$T_A = I \dot{\omega} K = 0.05 \times 2.79 \times 5$$

$$= 0.698 \text{ (N} \cdot \text{m) } \dots \text{③}$$

From the Effective Torque Table (graph) on page 10, select a model where the torque is more than ③ 0.698 (N·m) at 0.5 MPa.

That is, **RAF10** ~ **RAF70**.

4. Check mass moment of inertia in relation to swing time

Use the graph on page 20 "Mass moment of inertia in relation to swing time limits (swing angle 180°)" to select an actuator with a swing angle for the following conditions.

■Conditions

- Applied pressure: 0.5 (MPa)
- Mass moment of inertia I: 0.05 (kg·m<sup>2</sup>)
- Swing time: 1.5 (s)/180°

For RAF10

Cannot be used because it is below the curve.

For RAF20

Can be used because it is above the curve, but there is little leeway.

For RAF25

Can be used because it is above the curve. There is approximately 0.5 (s) of leeway.

Select **RAF25** because there is little leeway when using the **RAF20**.

●Calculation example

1. Check operating conditions

- ① Swing angle  $\theta$ : 3.14 [rad.]←180°
- ② Swing time t: 1.5 [sec.]
- ③ Applied pressure P: 73 [psi]
- ④ Load shape Disk  
Diameter d: 0.656 [ft.]  
Weight w: 22.05 [lb.]

2. Check swing time

The swing time is expressed as 0.75 sec./90° for 90°, which is within the range of 0.2 - 7.0 sec./90°, and satisfactory.

3. Select by the torque

Find the mass moment of inertia I.

$$I = \frac{wd^2}{8 \times 32.2} = \frac{22.05 \times 0.656^2}{8 \times 32.2}$$

$$= 0.0368 \text{ [lb} \cdot \text{ft} \cdot \text{sec}^2] \dots \text{①}$$

Find the uniform angular acceleration  $\dot{\omega}$ .

$$\dot{\omega} = \frac{2\theta}{t^2} = \frac{2 \times 3.14}{1.5^2}$$

$$= 2.79 \text{ [rad./sec}^2] \dots \text{②}$$

From ① and ②, the necessary torque  $T_A$  is

$$T_A = I \dot{\omega} K = 0.0368 \times 2.79 \times 5$$

$$= 0.513 \text{ [lb} \cdot \text{ft.} ] \dots \text{③}$$

From the Effective Torque Table (graph) on page 10, select a model where the torque is more than ③ 0.513 [lb·ft.] at 73 psi.

That is, **RAF10** ~ **RAF70**.

4. Check mass moment of inertia in relation to swing time

Use the graph on page 20 "Mass moment of inertia in relation to swing time limits (swing angle 180°)" to select an actuator with a swing angle for the following conditions.

■Conditions

- Applied pressure: 73 [psi]
- Mass moment of inertia I: 0.0368 [lb·ft·sec<sup>2</sup>]
- Swing time: 1.5 sec./180°

For RAF10

Cannot be used because it is below the curve.

For RAF20

Can be used because it is above the curve, but there is little leeway.

For RAF25

Can be used because it is above the curve. There is approximately 0.5 [sec.] of leeway.

Select **RAF25** because there is little leeway when using the **RAF20**.

### 5. Check load ratio

[Thrust load]

$$W_s = 10 \times 9.8 = 98 \text{ (N)}$$

[Radial load]

Because radial load is not applied

$$W_R = 0 \text{ (N)}$$

[Moment]

Because moment is not applied

$$M = 0 \text{ (N}\cdot\text{m)}$$

The load ratios of each load and moment are:

$$\frac{W_s}{W_{s \text{ MAX}}} = \frac{98}{20720} = 0.005 < \frac{1}{30} \doteq 0.033$$

$$\frac{W_R}{W_{R \text{ MAX}}} = \frac{0}{9120} < \frac{1}{30} \doteq 0.033$$

$$\frac{M}{M_{\text{MAX}}} = \frac{0}{212} < \frac{1}{30} \doteq 0.033$$

So, it is satisfactory.

$$\begin{aligned} \text{Total load ratio} &= \frac{W_s}{W_{s \text{ MAX}}} + \frac{W_R}{W_{R \text{ MAX}}} + \frac{M}{M_{\text{MAX}}} \\ &= \frac{98}{20720} + \frac{0}{9120} + \frac{0}{212} \\ &= 0.005 < \frac{1}{30} \doteq 0.033 \end{aligned}$$

Total load ratio is below 0.033, so it is satisfactory.

### 6. Check the unit specifications

**RAF25-180-SS2** satisfies operating conditions if selected.

### 5. Check load ratio

[Thrust load]

$$W'_s = W = 22.05 \text{ [lbf.]}$$

[Radial load]

Because radial load is not applied

$$W'_R = 0 \text{ (N)}$$

[Moment]

Because moment is not applied

$$M = 0 \text{ [ft}\cdot\text{lbf.]}$$

The load ratios of each load and moment are:

$$\frac{W_s}{W_{s \text{ MAX}}} = \frac{22.05}{4658} = 0.0047 < \frac{1}{30} \doteq 0.033$$

$$\frac{W_R}{W_{R \text{ MAX}}} = \frac{0}{2050} < \frac{1}{30} \doteq 0.033$$

$$\frac{M}{M_{\text{MAX}}} = \frac{0}{156.4} < \frac{1}{30} \doteq 0.033$$

So, it is satisfactory.

$$\begin{aligned} \text{Total load ratio} &= \frac{W_s}{W_{s \text{ MAX}}} + \frac{W_R}{W_{R \text{ MAX}}} + \frac{M}{M_{\text{MAX}}} \\ &= \frac{22.05}{4658} + \frac{0}{2050} + \frac{0}{156.4} \\ &= 0.0047 < \frac{1}{30} \doteq 0.033 \end{aligned}$$

Total load ratio is below 0.033, so it is satisfactory.

### 6. Check the unit specifications

**RAF25-180-SS2** satisfies operating conditions if selected.

# Selection

## Mass moment of inertia in relation to swing time limits

### Swing angle (90°)

Can be used in the range that is above the curve in the graph.  
Be sure to refer to "Precautions for mass moment of inertia in relation to swing time limits" on page 19 when making a selection.

#### RAF10

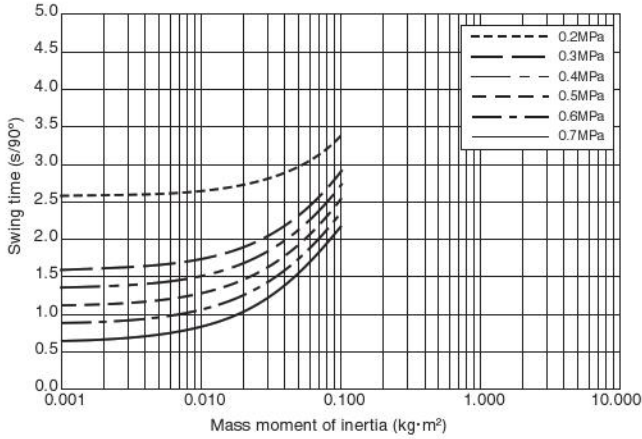

#### RAF20

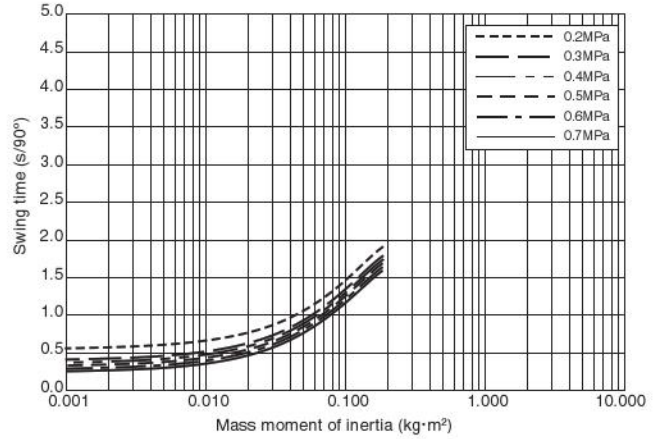

1 MPa = 145 psi 1 kg·m<sup>2</sup> = 0.7375 lbf·ft·sec.<sup>2</sup>

#### RAF25

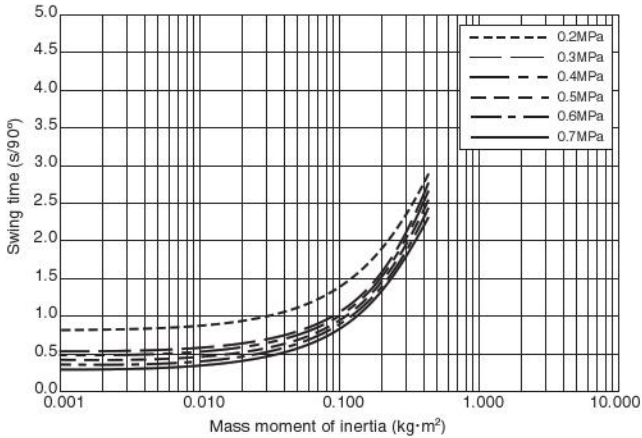

#### RAF30

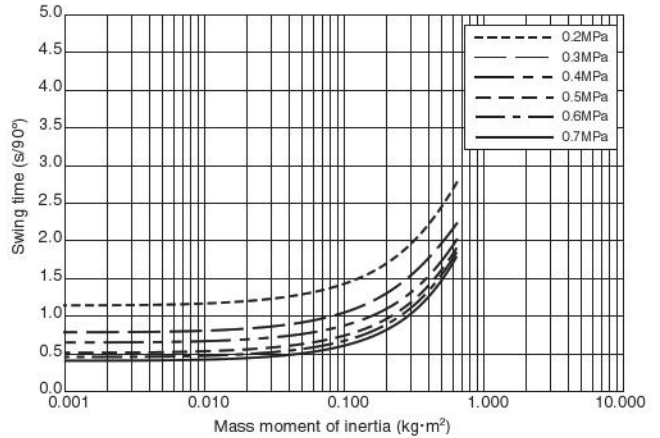

1 MPa = 145 psi 1 kg·m<sup>2</sup> = 0.7375 lbf·ft·sec.<sup>2</sup>

#### RAF50

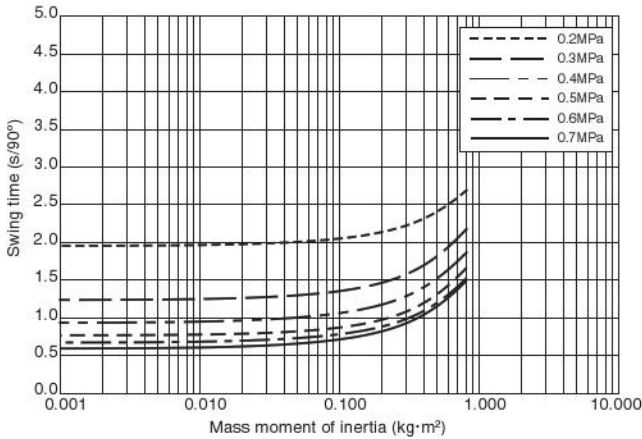

#### RAF70

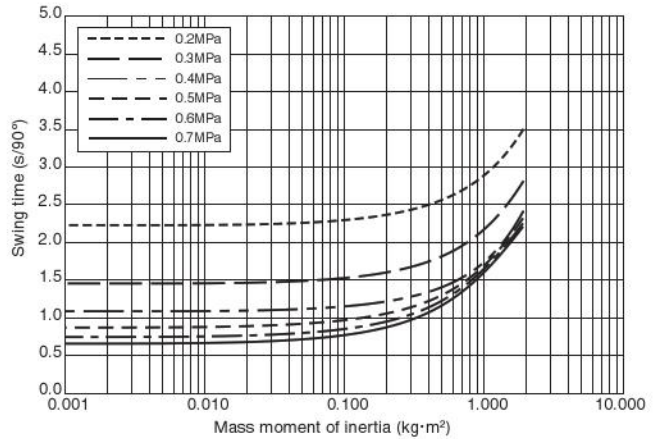

1 MPa = 145 psi 1 kg·m<sup>2</sup> = 0.7375 lbf·ft·sec.<sup>2</sup>

**Mass moment of inertia in relation to swing time limits**

**Swing angle (180°)**

Can be used in the range that is above the curve in the graph.  
Be sure to refer to "Precautions for mass moment of inertia in relation to swing time limits" on page 16 when making a selection.

**RAF10**

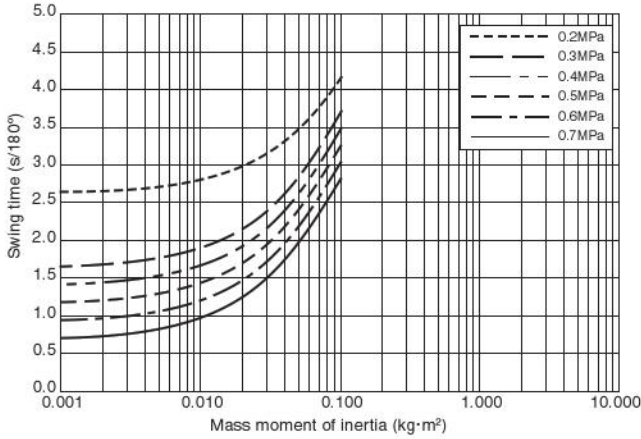

**RAF20**

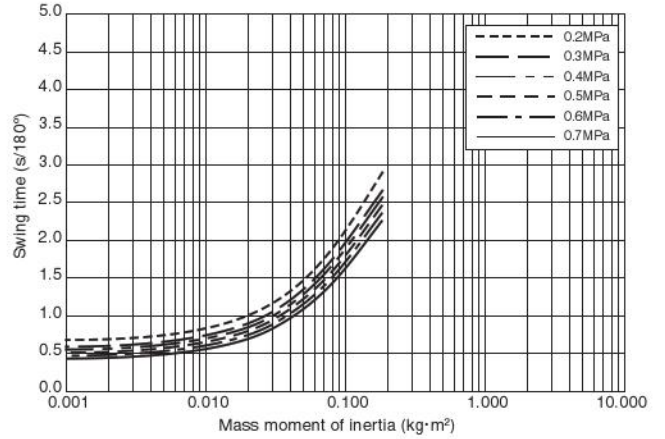

1 MPa = 145 psi 1 kg·m² = 0.7375 lbf·ft·sec.²

**RAF25**

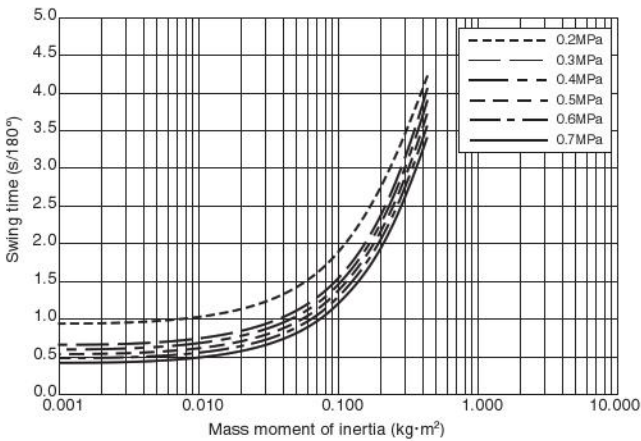

**RAF30**

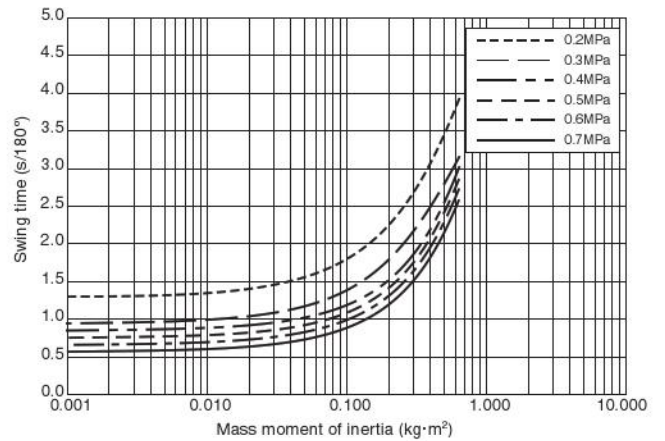

1 MPa = 145 psi 1 kg·m² = 0.7375 lbf·ft·sec.²

**RAF50**

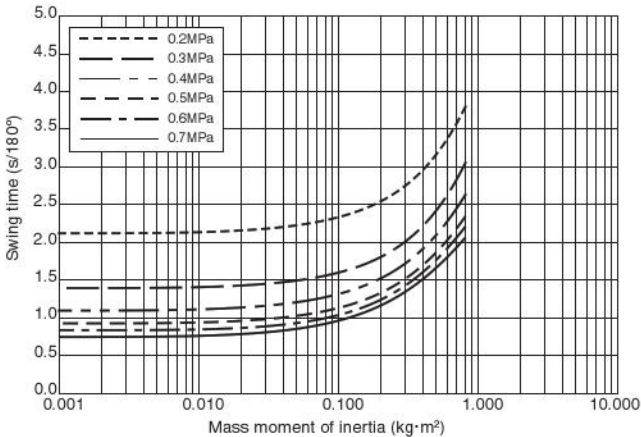

**RAF70**

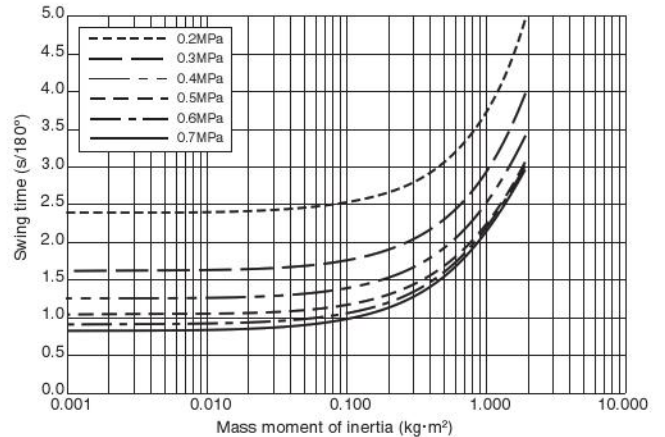

1 MPa = 145 psi 1 kg·m² = 0.7375 lbf·ft·sec.²

# Rotary Actuators Piston Type

## Flat Rotary Actuators

### Specifications

### Symbol

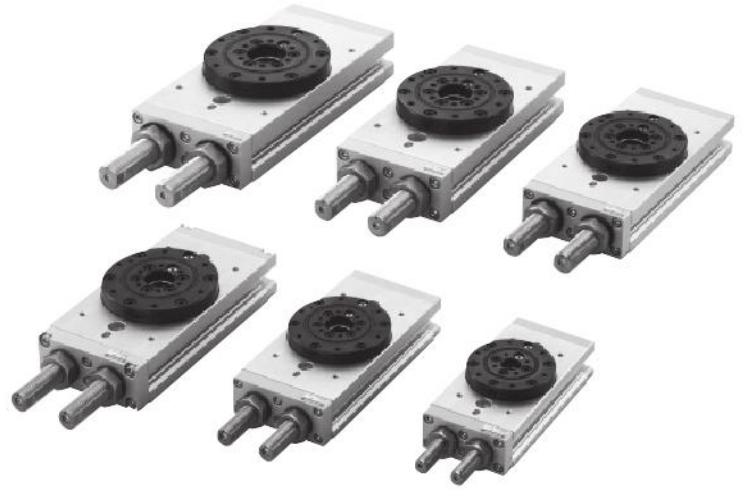
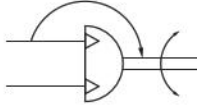

### Specifications

| Item  | Model  | RAF10-180-□  | RAF20-180-□    | RAF25-180-□    | RAF30-180-□    | RAF50-180-□    | RAF70-180-□    |               |
|---|--|--|----------------|----------------|----------------|----------------|----------------|---------------|
| Operating type  |  | Double acting double piston type<br>(Rack and pinion type) |                |                |                |                |                |               |
| Effective torque (at 0.5 MPa [73 psi]) <sup>Note 1</sup>                  | N·m [ft.·lbf.]                                       | 0.96 [0.708]   | 2.13 [1.571]   | 2.34 [1.726]   | 3.57 [2.633]   | 4.70 [3.467]   | 6.65 [4.905]   |               |
| Medium  |  | Air  |                |                |                |                |                |               |
| Operating pressure range  | MPa [psi]  | 0.2~0.7 [29~102]   |                |                |                |                |                |               |
| Proof pressure  | MPa [psi]  | 1.05 [152]   |                |                |                |                |                |               |
| Operating temperature range   | °C [°F]  | 0~60 [32~140]  |                |                |                |                |                |               |
| Cushion   | With shock absorber                                  | Shock absorber   |                |                |                |                |                |               |
|   | Without shock absorber (with plug) <sup>Note 2</sup> | None   |                |                |                |                |                |               |
| Swing angle range   |  | -5°~185°   |                |                |                |                |                |               |
| Swing angle adjustment range (only with shock absorber) <sup>Note 3</sup> |  | Clockwise rotation end: -5°~110°                           |                |                |                |                |                |               |
|   |  | Counterclockwise rotation end: 185°~70°                    |                |                |                |                |                |               |
| Swing time adjustment range <sup>Note 4</sup>                             | s/90°  | 0.2~7.0  |                |                |                |                |                |               |
| Bearing static load rating <sup>Note 5</sup>                              | Thrust load  | N [lbf.]   | 8700 [1956]    | 12380 [2783]   | 20720 [4658]   | 24090 [5415]   | 25680 [5773]   | 47500 [10678] |
|   | Radial load  | N [lbf.]   | 3830 [861]     | 5450 [1225]    | 9120 [2050]    | 10600 [2383]   | 11300 [2540]   | 20900 [4698]  |
|   | Moment   | N·m [ft.·lbf.]   | 65 [47.9]      | 110 [81.1]     | 212 [156.4]    | 272 [200.6]    | 319 [235.3]    | 668 [492.7]   |
| Lubrication   |  | Prohibited   |                |                |                |                |                |               |
| Port size   |  | M5×0.8   |                |                | Rc1/8          |                |                |               |
| Cylinder bore size  | mm [in.]   | φ 12 [0.472]×2   | φ 16 [0.630]×2 | φ 16 [0.630]×2 | φ 18 [0.709]×2 | φ 20 [0.787]×2 | φ 22 [0.866]×2 |               |
| Through hole diameter   | mm [in.]   | φ 10 [0.394]   | φ 13 [0.512]   | φ 15 [0.591]   | φ 19 [0.748]   | φ 19 [0.748]   | φ 22 [0.866]   |               |
| Mass  | g [oz.]  | With shock absorber  | 668 [23.56]    | 1018 [35.91]   | 1513 [53.37]   | 1924 [67.87]   | 2602 [91.78]   | 3445 [121.52] |
|   |  | Without shock absorber (with plug)                         | 632 [22.29]    | 953 [33.62]    | 1409 [49.70]   | 1766 [62.29]   | 2393 [84.41]   | 3144 [110.90] |

Note 1: Actual measured values, and are not guaranteed values.

2: When the actuator does not have shock absorbers, be sure to install an external shock absorber or stopper mechanism so the rack does not hit the plug.

3: For position of swing end, see page 24

4: Swing time at midpoint where shock absorbers do not affect operation, with no load at air pressure of 0.5 MPa [73 psi].

5: Apply 1/30th or less of the static load rating of the bearing during usage.

### Shock absorber specifications

| Applicable models                    |              | RAF10         | RAF20       | RAF25       | RAF30       | RAF50       | RAF70        |
|--------------------------------------|--------------|---------------|-------------|-------------|-------------|-------------|--------------|
| Item                                 | Model        | KSHK10×5-01   | KSHK12×6-01 | KSHK14×7-01 | KSHK16×8-01 | KSHK18×9-01 | KSHK20×10-01 |
| Maximum absorption <sup>Note 1</sup> | J [ft.·lbf.] | 0.4 [0.30]    | 0.8 [0.59]  | 1 [0.74]    | 1.6 [1.18]  | 2.5 [1.84]  | 5 [3.7]      |
| Absorption stroke                    | mm [in.]     | 5 [0.20]      | 6 [0.24]    | 7 [0.28]    | 8 [0.32]    | 9 [0.35]    | 10 [0.39]    |
| Max. operating frequency             | cycle/min    | 30            |             |             |             |             |              |
| Angle variation                      |              | 1° or less    |             |             |             |             | 3° or less   |
| Operating temperature range          | °C [°F]      | 0~60 [32~140] |             |             |             |             |              |
| Weight <sup>Note 2</sup>             | g [oz.]      | 31 [1.09]     | 49 [1.73]   | 76 [2.68]   | 110 [3.88]  | 149 [5.26]  | 207 [7.30]   |

Note 1: Values are for a normal temperature (20~25°C [68~77°F]). Be aware that performance and characteristics change depending on the operating temperature.

2: Weight includes seal washer and hexagon nut.

Remark 1: Never exceed the flat rotary actuator's swing time limits in relation to mass moment of inertia, even if it is within the shock absorbing capacity range.

2: The screw on the rear end of the shock absorber should never be loosened or removed. Oil may leak out of the shock absorber leading to a loss of functionality and resulting in damage to the equipment and accidents.

3: The life of a shock absorber may vary from the flat rotary actuator series depending on the operating conditions.

## Order Codes

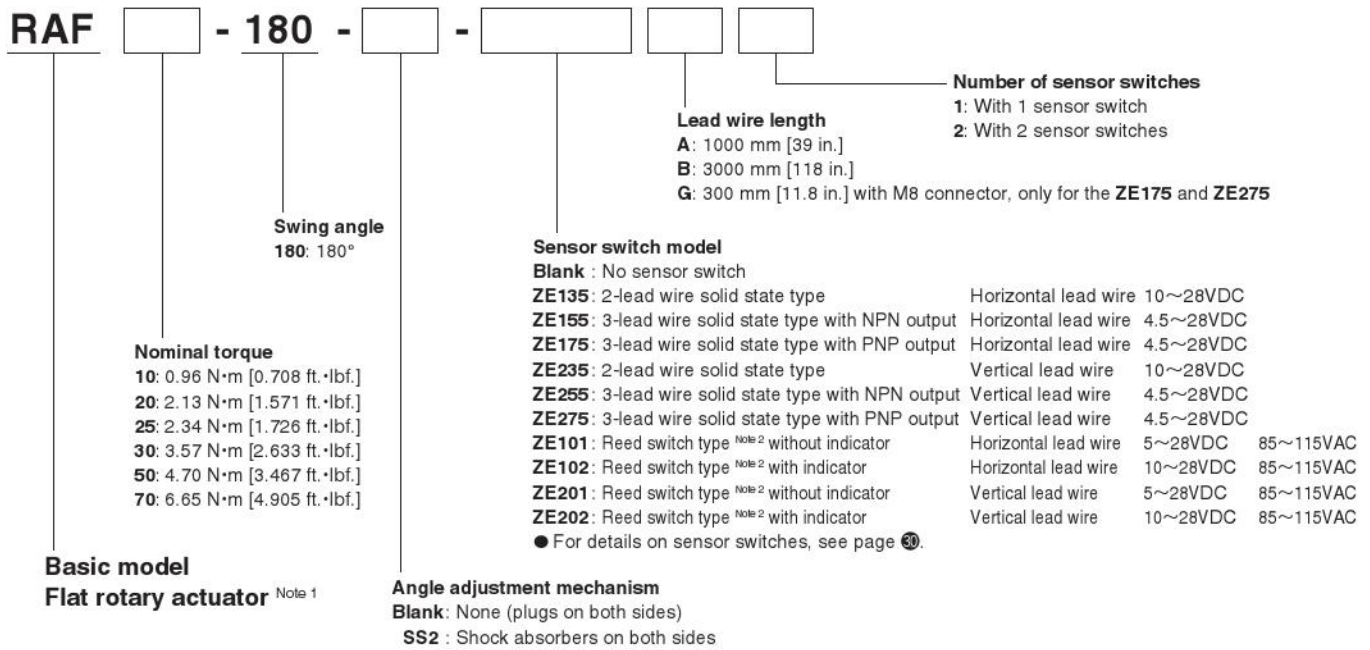

Note 1: The flat rotary actuator comes with magnets as standard.  
 Note 2: When using reed switch type, be careful of allowable swing time.  
 See page 30 for details.

## Additional parts

### ●Locating pin for body

**P1-RAF** [ ]

**1020:** For RAF10, 20  
**2530:** For RAF25, 30  
**5070:** For RAF50, 70

### ●Locating ring for bottom of body

**R-RAF** [ ]

**10:** For RAF10  
**20:** For RAF20  
**25:** For RAF25  
**30:** For RAF30  
**50:** For RAF50  
**70:** For RAF70

### ●Locating pin for cross roller bearing

**P2-RAF** [ ]

**1020:** For RAF10, 20  
**2530:** For RAF25, 30  
**5070:** For RAF50, 70

### ●Spacer for cross roller bearing

**SP-RAF** [ ]

**10:** For RAF10  
**20:** For RAF20  
**25:** For RAF25  
**30:** For RAF30  
**50:** For RAF50  
**70:** For RAF70

### ●Shock absorber (seal washer, hexagon nut included)

**KSHK10×5-01** (For RAF10)  
**KSHK12×6-01** (For RAF20)  
**KSHK14×7-01** (For RAF25)  
**KSHK16×8-01** (For RAF30)  
**KSHK18×9-01** (For RAF50)  
**KSHK20×10-01** (For RAF70)

Remark: If you do not need seal washers and hexagon nuts, write - **NN** at the end of the order code above.

### ●Seal washer and hexagon nut for shock absorber

**MK** [ ] - **KSHK** [ ]

#### Parts

**1:** Seal washer  
**2:** Hexagon nut  
**3:** Seal washer and hexagon nut

#### Thread size

**10:** M10×1  
**12:** M12×1  
**14:** M14×1.5  
**16:** M16×1.5  
**18:** M18×1.5  
**20:** M20×1.5

## Inner Construction

### ●With shock absorber

### ●Without angle adjustment mechanism (plug on both sides)

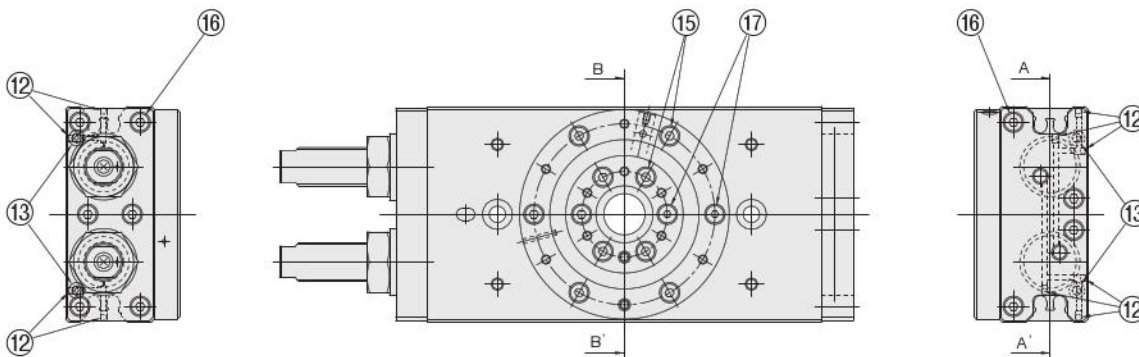
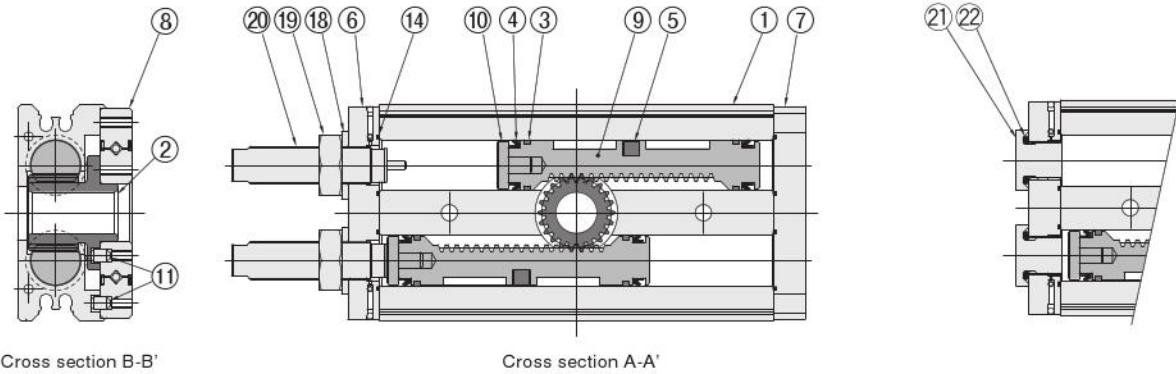

Diagrams are RAF20-180-SS2

## Major parts and materials

| No. | Parts                | Materials                           |       |       |       |  |                                     |
|-----|----------------------|-------------------------------------|-------|-------|-------|--|-------------------------------------|
|     |                      | RAF10                               | RAF20 | RAF25 | RAF30 | RAF50                                    | RAF70                               |
| ①   | Body                 | Aluminum alloy (anodized)           |       |       |       |  |                                     |
| ②   | Pinion               | Steel (nickel plated)               |       |       |       |  |                                     |
| ③   | Wear ring            | Plastic                             |       |       |       |  |                                     |
| ④   | Seal                 | Synthetic rubber (NBR)              |       |       |       |  |                                     |
| ⑤   | Magnet               | Plastic magnet                      |       |       |       |  |                                     |
| ⑥   | Side plate A         | Aluminum alloy (anodized)           |       |       |       |  |                                     |
| ⑦   | Side plate B         | Aluminum alloy (anodized)           |       |       |       |  |                                     |
| ⑧   | Cross roller bearing | Steel (plastic impregnated coating) |       |       |       |  |                                     |
| ⑨   | Rack                 | Stainless steel (nickel plated)     |       |       |       |  |                                     |
| ⑩   | Striker              | Special steel                       |       |       | Steel |  |                                     |
| ⑪   | Pin                  | Stainless steel                     |       |       |       |  |                                     |
| ⑫   | Steel ball           | Steel                               |       |       |       |  |                                     |
| ⑬   | O-ring               | Synthetic rubber (NBR)              |       |       |       |  |                                     |
| ⑭   | O-ring               | Synthetic rubber (NBR)              |       |       |       |  |                                     |
| ⑮   | Screw                | Steel (black oxide finish)          |       |       |       |  |                                     |
| ⑯   | Screw                | Stainless steel                     |       |       |       |  |                                     |
| ⑰   | Screw                | Steel (nickel plated)               |       |       |       |  |                                     |
| ⑱   | Seal washer          | Mild steel + synthetic rubber (NBR) |       |       |       | Stainless steel + synthetic rubber (NBR) | Mild steel + synthetic rubber (NBR) |
| ⑲   | Hexagon nut          | Stainless steel                     |       |       |       |  |                                     |
| ⑳   | Shock absorber       | —                                   |       |       |       |  |                                     |
| ㉑   | Plug                 | Stainless steel                     |       |       |       |  |                                     |
| ㉒   | O-ring               | Synthetic rubber (NBR)              |       |       |       |  |                                     |

## Swing angle range and swing direction

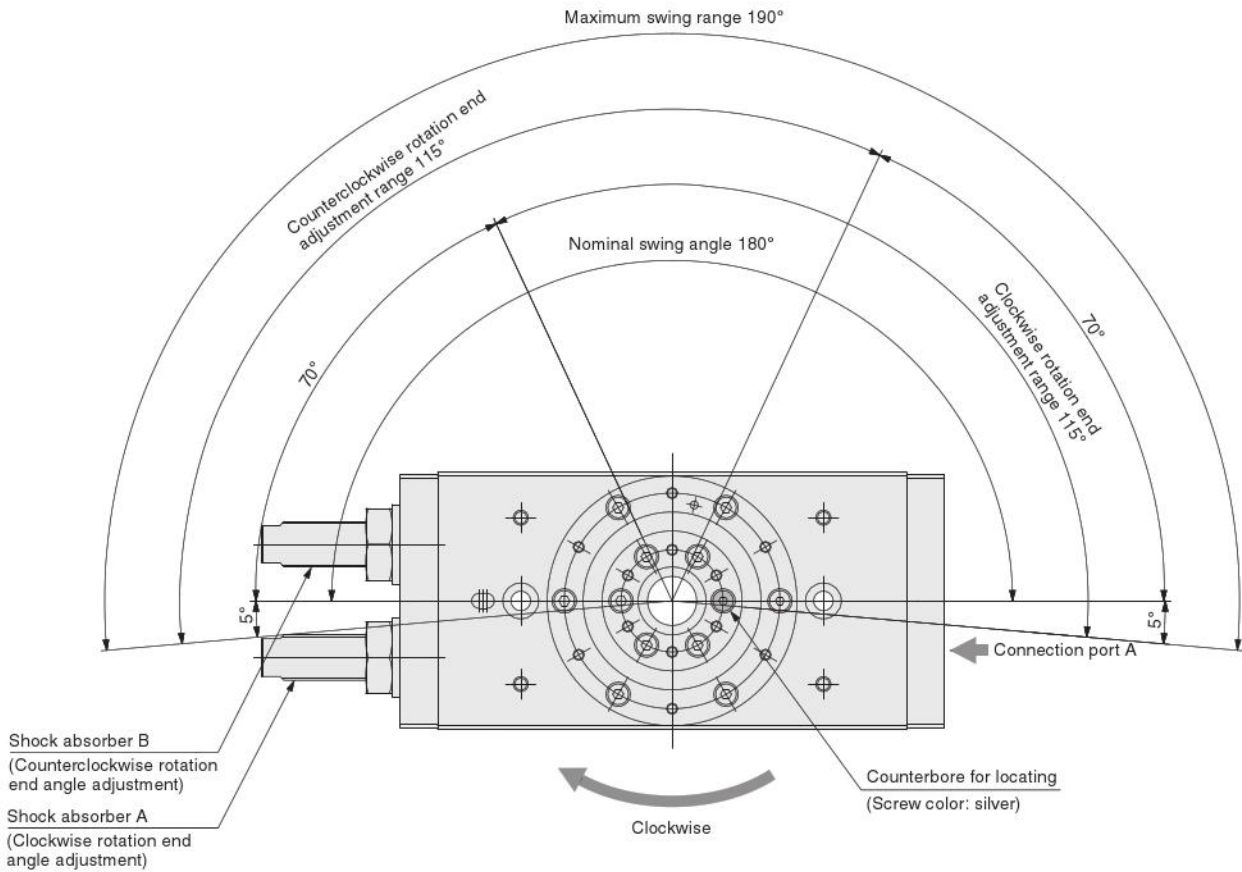

Note: It is possible to adjust the swing angle by how far the shock absorber is screwed in, but adjust it so the swing angle is 30° or more. The swing angle for one rotation of shock absorber is shown below.

| Model         | Shock absorber thread size A | Angle adjustment by one rotation of shock absorber <sup>Note</sup> |
|---------------|------------------------------|--|
| RAF10-180-SS2 | M10×1                        | 6.5°   |
| RAF20-180-SS2 | M12×1                        | 5.2°   |
| RAF25-180-SS2 | M14×1.5                      | 6.9°   |
| RAF30-180-SS2 | M16×1.5                      | 5.7°   |
| RAF50-180-SS2 | M18×1.5                      | 5.5°   |
| RAF70-180-SS2 | M20×1.5                      | 4.8°   |

Note: Values vary due to tolerances of parts. Use them as guidelines.

Remark: The diagram shows when air is supplied to connection port A on the clockwise rotation side, and the inner ring of the cross roller bearing has completed the rotation in the clockwise direction (0° location).

## Port location and swing direction

Inner ring of cross roller bearing rotates clockwise when air is supplied to port A, and rotates counterclockwise when air is supplied to port B.

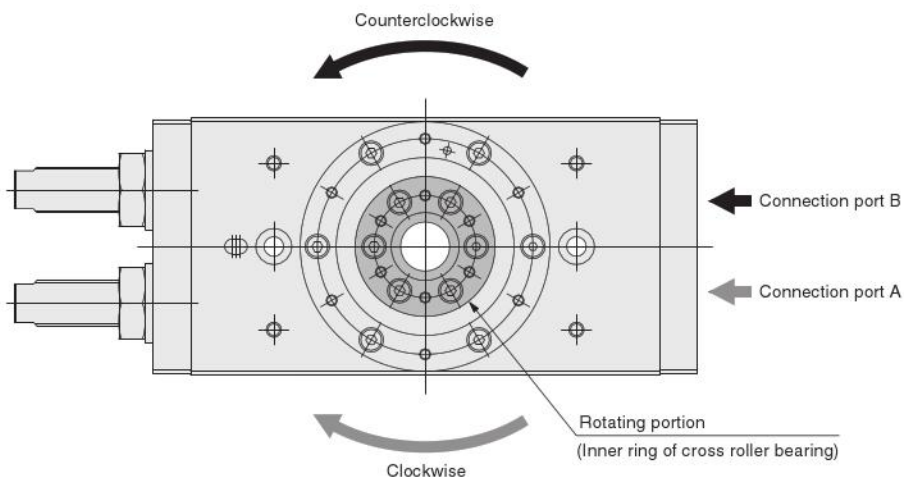

### RAF10-180-SS2 (with shock absorbers)

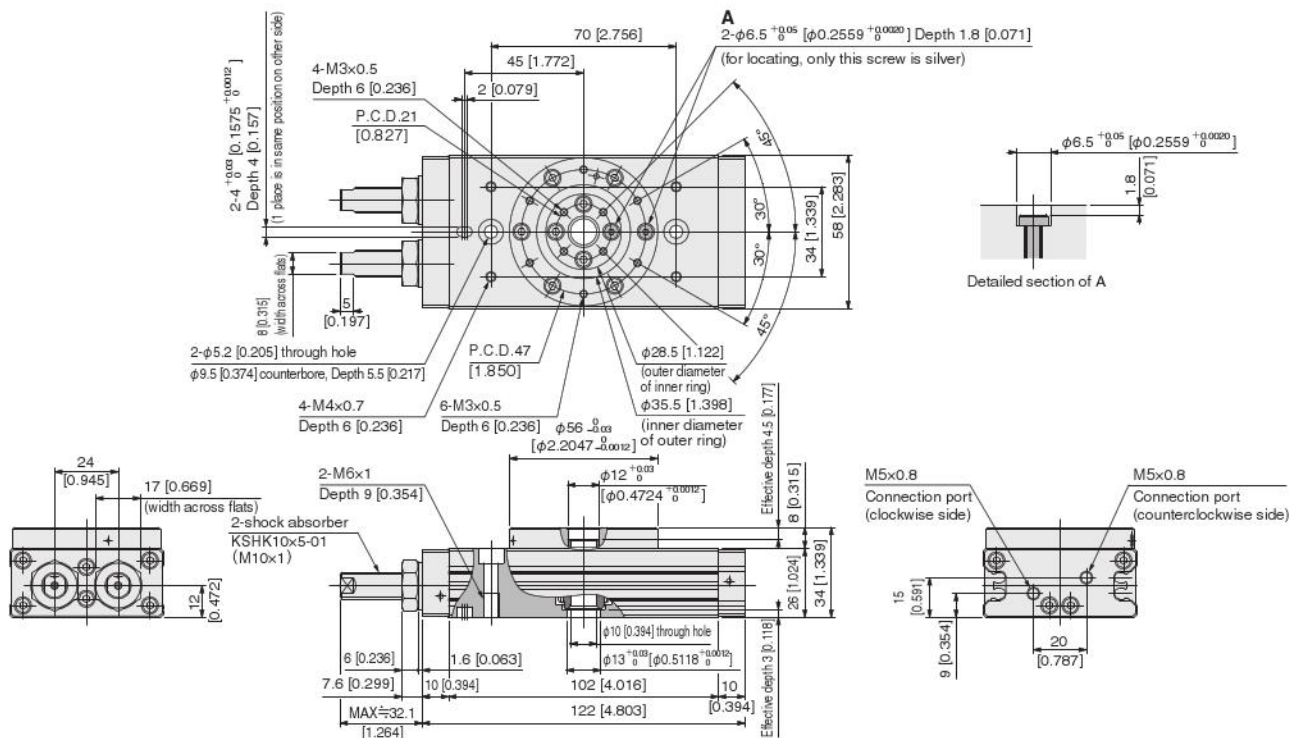

Remark: The diagrams show when air is supplied to connection port A on the clockwise rotation side, and the table has completed the rotation in the clockwise direction (0° location). See page 24 for information about swing direction.

### RAF10-180 (without angle adjustment mechanism)

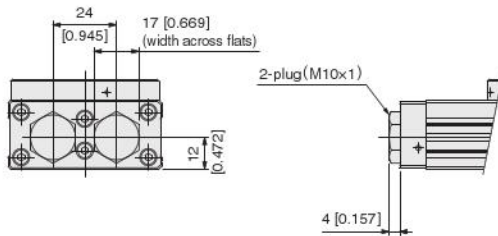

Note: Do not insert screws beyond the thread depth. Be sure to see "Mounting" under Handling Instructions and Precautions on page 7 when mounting the body or workpiece.

### Shock absorber dimensions mm [in.]

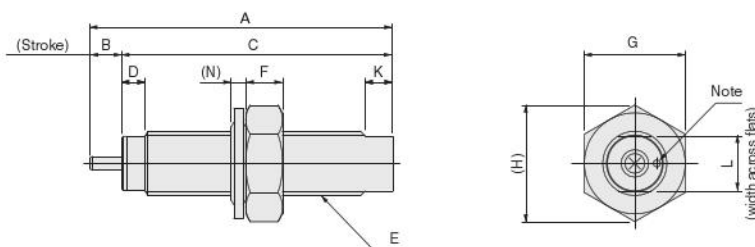

Note: Do not block the air path port.

| Model        | A          | B          | C          | D         | E       | F          | G          | H            | J           | K         | L          | N           |
|--------------|------------|------------|------------|-----------|---------|------------|------------|--------------|-------------|-----------|------------|-------------|
| KSHK10×5-01  | 48 [1.890] | 5 [0.197]  | 43 [1.693] | 5 [0.197] | M10×1   | 6 [0.236]  | 17 [0.669] | 19.6 [0.772] | 2 [0.079]   | 5 [0.197] | 8 [0.315]  | 1.6 [0.063] |
| KSHK12×6-01  | 55 [2.165] | 6 [0.236]  | 49 [1.929] | 5 [0.197] | M12×1   | 7 [0.276]  | 19 [0.748] | 21.9 [0.862] | 2.5 [0.098] | 5 [0.197] | 10 [0.394] | 2 [0.079]   |
| KSHK14×7-01  | 66 [2.598] | 7 [0.276]  | 59 [2.323] | 5 [0.197] | M14×1.5 | 8 [0.315]  | 22 [0.866] | 25.4 [1.000] | 3 [0.118]   | 6 [0.236] | 12 [0.472] | 2 [0.079]   |
| KSHK16×8-01  | 73 [2.874] | 8 [0.315]  | 65 [2.559] | 5 [0.197] | M16×1.5 | 10 [0.394] | 24 [0.945] | 27.7 [1.091] | 3 [0.118]   | 7 [0.276] | 13 [0.512] | 2 [0.079]   |
| KSHK18×9-01  | 79 [3.110] | 9 [0.354]  | 70 [2.756] | 5 [0.197] | M18×1.5 | 11 [0.433] | 27 [1.063] | 31.2 [1.228] | 4 [0.157]   | 7 [0.276] | 15 [0.591] | 2 [0.079]   |
| KSHK20×10-01 | 88 [3.465] | 10 [0.394] | 78 [3.071] | 5 [0.197] | M18×1.5 | 12 [0.472] | 30 [1.181] | 34.6 [1.362] | 4 [0.157]   | 8 [0.315] | 17 [0.669] | 2 [0.079]   |

### RAF20-180-SS2 (with shock absorbers)

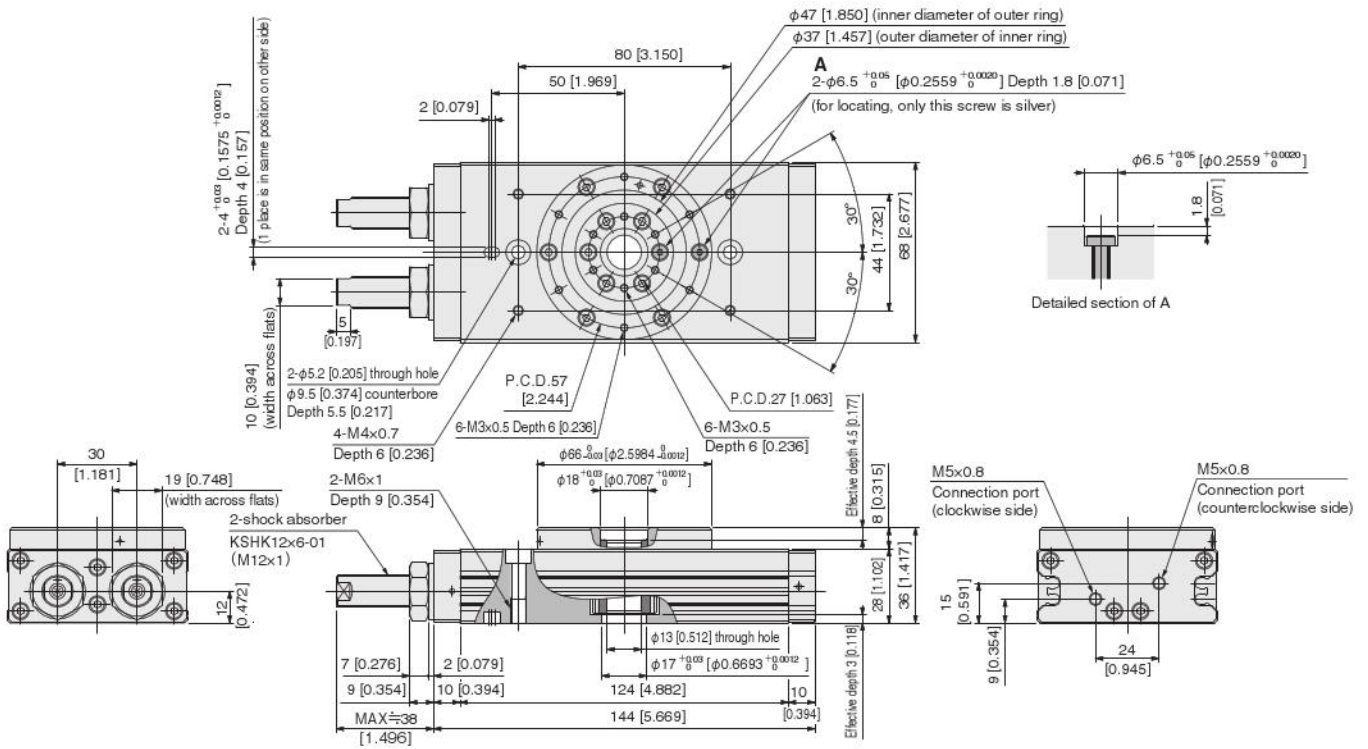

Remark: The diagrams show when air is supplied to connection port A on the clockwise rotation side, and the table has completed the rotation in the clockwise direction (0° location). See page 24 for information about swing direction.

### RAF20-180 (without angle adjustment mechanism)

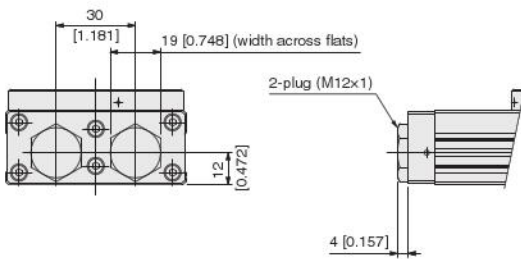

Note: Do not insert screws beyond the thread depth. Be sure to see "Mounting" under Handling Instructions and Precautions on page 7 when mounting the body or workpiece.

**RAF25-180-SS2 (with shock absorbers)**

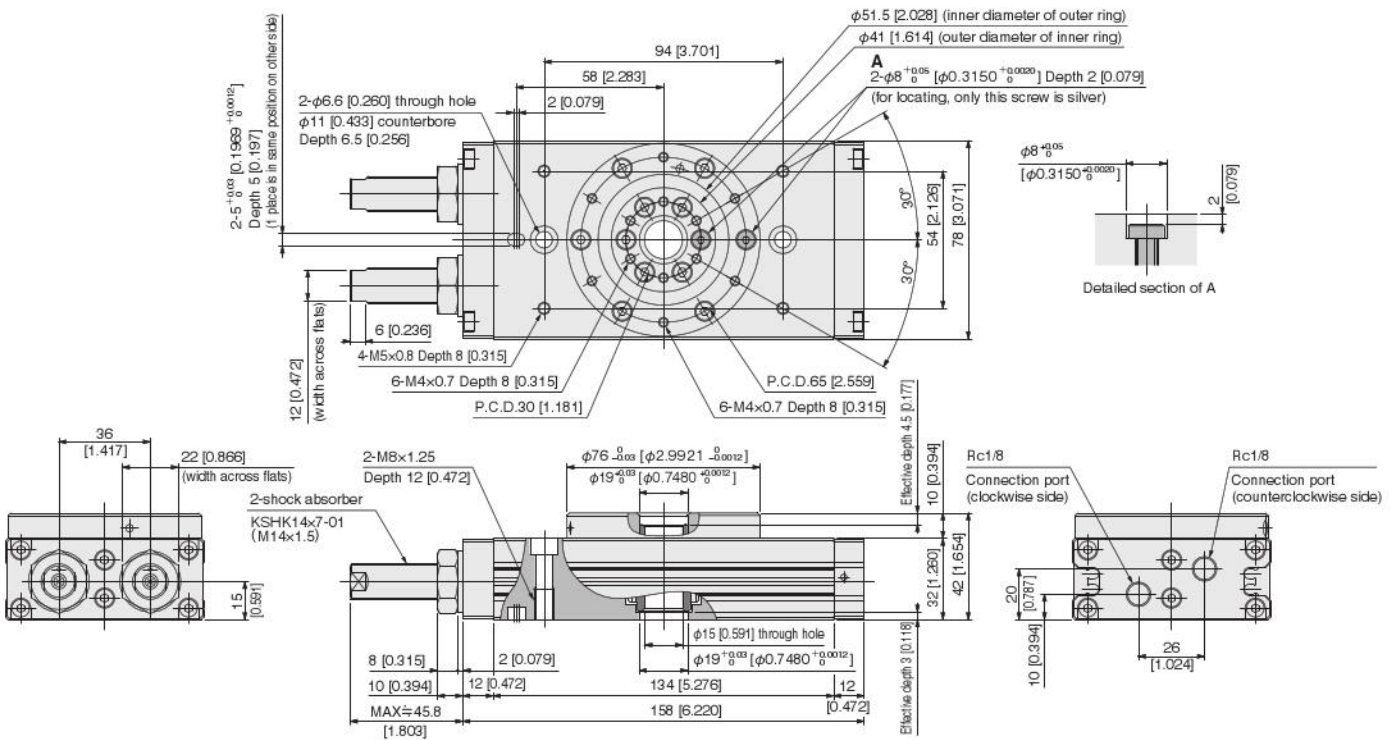

Remark: The diagrams show when air is supplied to connection port A on the clockwise rotation side, and the table has completed the rotation in the clockwise direction (0° location). See page 24 for information about swing direction.

**RAF25-180 (without angle adjustment mechanism)**

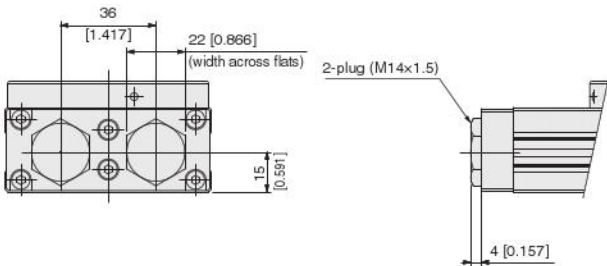

Note: Do not insert screws beyond the thread depth. Be sure to see "Mounting" under Handling Instructions and Precautions on page 7 when mounting the body or workpiece.

With shock absorbers

- RAF30-180-SS2
- RAF50-180-SS2
- RAF70-180-SS2

Remark: The diagrams show when air is supplied to connection port A on the clockwise rotation side, and the table has completed the rotation in the clockwise direction (0° location). See page 24 for information about swing direction.

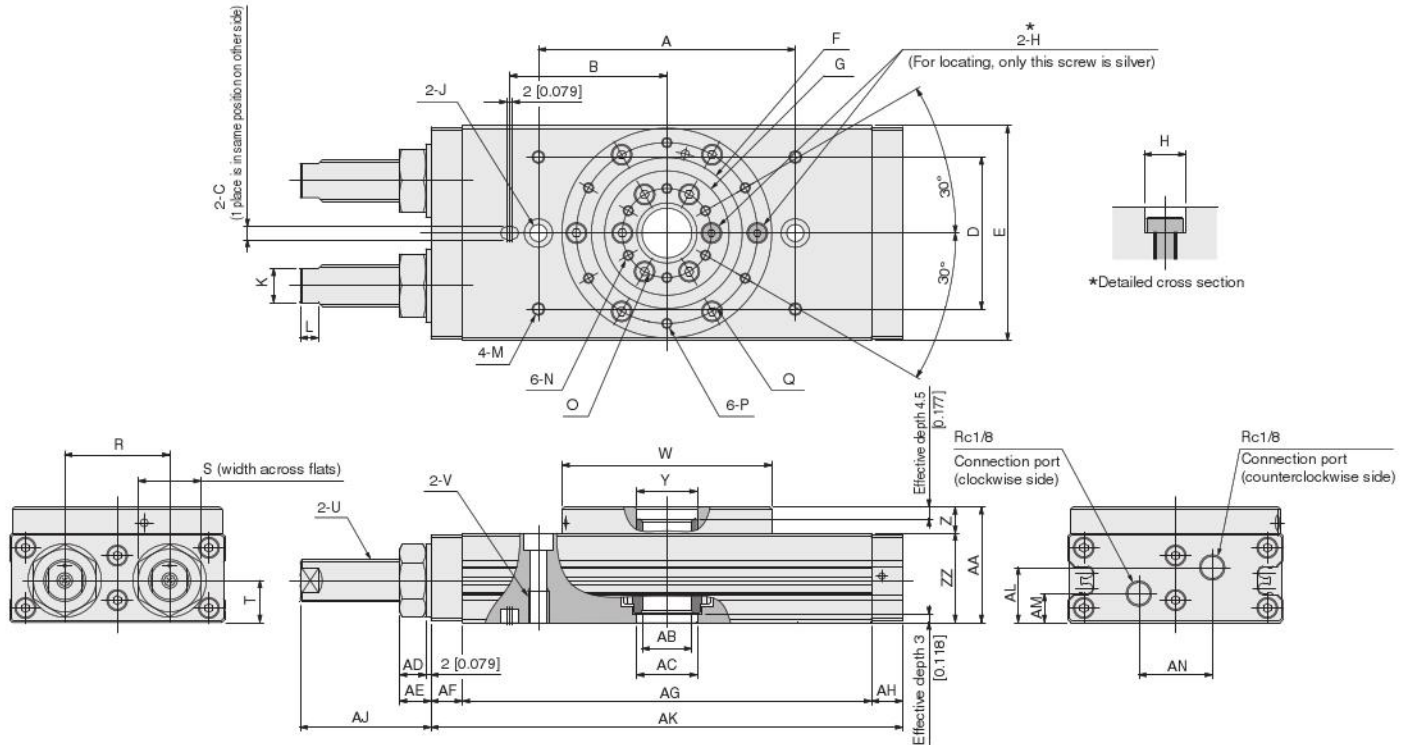

| Model         | A              | B             | C   | D             | E              | F                 | G                 | H   | J  | K             |
|---------------|----------------|---------------|---|---------------|----------------|-------------------|-------------------|---|--|---------------|
| RAF30-180-SS2 | 98<br>[3.858]  | 60<br>[2.362] | 5 <sup>+0.03</sup> <sub>0</sub> [0.1969 <sup>+0.0012</sup> ]<br>Depth 5 [0.197] | 58<br>[2.283] | 82<br>[3.228]  | φ57.5<br>[φ2.264] | φ47.5<br>[φ1.870] | φ8 <sup>+0.05</sup> <sub>0</sub> [φ0.3150 <sup>+0.0020</sup> ]<br>Depth 2 [0.079]     | φ6.6 [0.260] through hole, φ11 [0.433] counterbore,<br>Depth 6.5 [0.256] | 13<br>[0.512] |
| RAF50-180-SS2 | 110<br>[4.331] | 68<br>[2.677] | 6 <sup>+0.03</sup> <sub>0</sub> [0.2362 <sup>+0.0012</sup> ]<br>Depth 6 [0.236] | 68<br>[2.677] | 90<br>[3.543]  | φ61.5<br>[φ2.421] | φ51<br>[φ2.008]   | φ9.5 <sup>+0.05</sup> <sub>0</sub> [φ0.3740 <sup>+0.0020</sup> ]<br>Depth 2.2 [0.087] | φ8.6 [0.339] through hole, φ14 [0.551] counterbore,<br>Depth 8.6 [0.339] | 15<br>[0.591] |
| RAF70-180-SS2 | 120<br>[4.724] | 73<br>[2.874] | 6 <sup>+0.03</sup> <sub>0</sub> [0.2362 <sup>+0.0012</sup> ]<br>Depth 6 [0.236] | 78<br>[3.071] | 100<br>[3.937] | φ72<br>[φ2.835]   | φ57.4<br>[φ2.260] | φ9.5 <sup>+0.05</sup> <sub>0</sub> [φ0.3740 <sup>+0.0020</sup> ]<br>Depth 2.2 [0.087] | φ8.6 [0.339] through hole, φ14 [0.551] counterbore,<br>Depth 8.6 [0.339] | 17<br>[0.669] |

| Model         | L            | M                      | N                       | O                | P                       | Q                | R             | S             | T             | U            | V                        |
|---------------|--------------|------------------------|-------------------------|------------------|-------------------------|------------------|---------------|---------------|---------------|--------------|--------------------------|
| RAF30-180-SS2 | 7<br>[0.276] | M5×0.8 Depth 8 [0.315] | M4×0.7 Depth 8 [0.315]  | P.C.D.34 [1.339] | M4×0.7 Depth 8 [0.315]  | P.C.D.69 [2.717] | 40<br>[1.575] | 24<br>[0.945] | 16<br>[0.630] | KSHK16×8-01  | M8×1.25 Depth 12 [0.472] |
| RAF50-180-SS2 | 7<br>[0.276] | M6×1 Depth 9 [0.354]   | M5×0.8 Depth 10 [0.394] | P.C.D.38 [1.496] | M5×0.8 Depth 10 [0.394] | P.C.D.75 [2.953] | 44<br>[1.732] | 27<br>[1.063] | 18<br>[0.709] | KSHK18×9-01  | M10×1.5 Depth 15 [0.591] |
| RAF70-180-SS2 | 8<br>[0.315] | M6×1 Depth 9 [0.354]   | M5×0.8 Depth 11 [0.433] | P.C.D.42 [1.654] | M5×0.8 Depth 11 [0.433] | P.C.D.85 [3.346] | 50<br>[1.969] | 30<br>[1.181] | 18<br>[0.709] | KSHK20×10-01 | M10×1.5 Depth 15 [0.591] |

| Model         | W   | Y  | Z             | ZZ            | AA            | AB                          | AC   | AD            | AE            | AF            | AG             | AH            | AJ                  | AK             | AL            | AM            | AN            |
|---------------|---|--|---------------|---------------|---------------|-----------------------------|--|---------------|---------------|---------------|----------------|---------------|---------------------|----------------|---------------|---------------|---------------|
| RAF30-180-SS2 | φ80 <sup>0</sup> <sub>-0.03</sub><br>[φ3.1496 <sup>0</sup> <sub>-0.0012</sub> ] | φ23 <sup>+0.03</sup> <sub>0</sub><br>[φ0.9055 <sup>+0.0012</sup> ] | 10<br>[0.394] | 34<br>[1.339] | 44<br>[1.732] | φ19 [0.748]<br>through hole | φ23 <sup>+0.03</sup> <sub>0</sub><br>[φ0.9055 <sup>+0.0012</sup> ] | 10<br>[0.394] | 12<br>[0.472] | 12<br>[0.472] | 156<br>[6.142] | 12<br>[0.472] | MAX.51.8<br>[2.039] | 180<br>[7.087] | 21<br>[0.827] | 11<br>[0.433] | 28<br>[1.102] |
| RAF50-180-SS2 | φ88 <sup>0</sup> <sub>-0.03</sub><br>[φ3.4646 <sup>0</sup> <sub>-0.0012</sub> ] | φ25 <sup>+0.03</sup> <sub>0</sub><br>[φ0.9843 <sup>+0.0012</sup> ] | 12<br>[0.472] | 38<br>[1.496] | 50<br>[1.969] | φ19 [0.748]<br>through hole | φ23 <sup>+0.03</sup> <sub>0</sub><br>[φ0.9055 <sup>+0.0012</sup> ] | 11<br>[0.433] | 13<br>[0.512] | 15<br>[0.591] | 162<br>[6.378] | 15<br>[0.591] | MAX.53.9<br>[2.122] | 192<br>[7.559] | 23<br>[0.906] | 13<br>[0.512] | 30<br>[1.181] |
| RAF70-180-SS2 | φ98 <sup>0</sup> <sub>-0.03</sub><br>[φ3.8583 <sup>0</sup> <sub>-0.0012</sub> ] | φ29 <sup>+0.03</sup> <sub>0</sub><br>[φ1.1417 <sup>+0.0012</sup> ] | 13<br>[0.512] | 40<br>[1.575] | 53<br>[2.087] | φ22 [0.866]<br>through hole | φ26 <sup>+0.03</sup> <sub>0</sub><br>[φ1.0236 <sup>+0.0012</sup> ] | 12<br>[0.472] | 14<br>[0.551] | 15<br>[0.591] | 184<br>[7.244] | 15<br>[0.591] | MAX.61.5<br>[2.421] | 214<br>[8.425] | 23<br>[0.906] | 13<br>[0.512] | 34<br>[1.339] |

Without angle adjustment mechanism

- RAF30-180
- RAF50-180
- RAF70-180

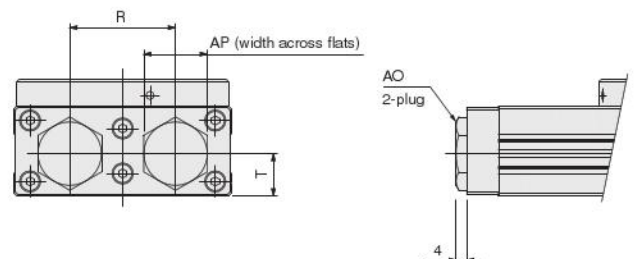

| Model     | AO      | AP         |
|-----------|---------|------------|
| RAF30-180 | M16×1.5 | 24 [0.945] |
| RAF50-180 | M18×1.5 | 27 [1.063] |
| RAF70-180 | M20×1.5 | 30 [1.181] |

Note: Do not insert screws beyond the thread depth. Be sure to see "Mounting" under Handling Instructions and Precautions on page 7 when mounting the body or workpiece.

●Locating pin for body

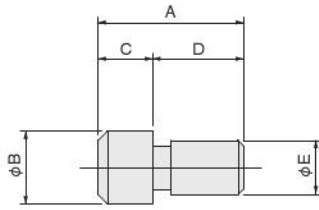

| Model             | A             | B  | C            | D            | E  | Mass g [oz.] |
|-------------------|---------------|--|--------------|--------------|--|--------------|
| <b>P1-RAF1020</b> | 8<br>[0.315]  | 4g6 $\begin{matrix} -0.004 \\ -0.012 \\ -0.00016 \\ -0.00047 \end{matrix}$ | 3<br>[0.118] | 5<br>[0.197] | 3g6 $\begin{matrix} -0.002 \\ -0.008 \\ -0.00008 \\ -0.00031 \end{matrix}$ | 1<br>[0.04]  |
| <b>P1-RAF2530</b> | 10<br>[0.394] | 5g6 $\begin{matrix} -0.004 \\ -0.012 \\ -0.00016 \\ -0.00047 \end{matrix}$ | 4<br>[0.157] | 6<br>[0.236] | 4g6 $\begin{matrix} -0.004 \\ -0.012 \\ -0.00016 \\ -0.00047 \end{matrix}$ | 2<br>[0.07]  |
| <b>P1-RAF5070</b> | 12<br>[0.472] | 6g6 $\begin{matrix} -0.004 \\ -0.012 \\ -0.00016 \\ -0.00047 \end{matrix}$ | 5<br>[0.197] | 7<br>[0.276] | 5g6 $\begin{matrix} -0.004 \\ -0.012 \\ -0.00016 \\ -0.00047 \end{matrix}$ | 3<br>[0.11]  |

●Locating pin for cross roller bearing

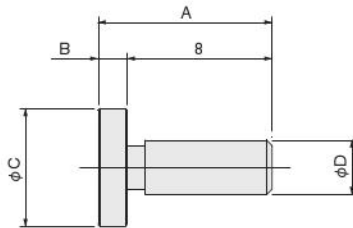

| Model             | A              | B              | C  | D  | Mass g [oz.] |
|-------------------|----------------|----------------|--|--|--------------|
| <b>P2-RAF1020</b> | 9.6<br>[0.378] | 1.6<br>[0.063] | 6.5g6 $\begin{matrix} -0.005 \\ -0.014 \\ -0.00020 \\ -0.00055 \end{matrix}$ | 3g6 $\begin{matrix} -0.002 \\ -0.008 \\ -0.00008 \\ -0.00031 \end{matrix}$ | 1<br>[0.04]  |
| <b>P2-RAF2530</b> | 9.8<br>[0.386] | 1.8<br>[0.071] | 8g6 $\begin{matrix} -0.005 \\ -0.014 \\ -0.00020 \\ -0.00055 \end{matrix}$   | 4g6 $\begin{matrix} -0.004 \\ -0.012 \\ -0.00016 \\ -0.00047 \end{matrix}$ | 2<br>[0.07]  |
| <b>P2-RAF5070</b> | 10<br>[0.394]  | 2<br>[0.079]   | 9.5g6 $\begin{matrix} -0.005 \\ -0.014 \\ -0.00020 \\ -0.00055 \end{matrix}$ | 5g6 $\begin{matrix} -0.004 \\ -0.012 \\ -0.00016 \\ -0.00047 \end{matrix}$ | 3<br>[0.11]  |

●Locating ring for bottom of body

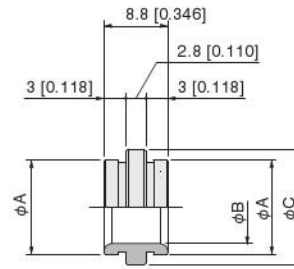

| Model          | A   | B             | C             | Mass g [oz.] |
|----------------|---|---------------|---------------|--------------|
| <b>R-RAF10</b> | 13g6 $\begin{matrix} -0.008 \\ -0.017 \\ -0.00024 \\ -0.00067 \end{matrix}$ | 10<br>[0.394] | 16<br>[0.630] | 5<br>[0.18]  |
| <b>R-RAF20</b> | 17g6 $\begin{matrix} -0.008 \\ -0.017 \\ -0.00024 \\ -0.00067 \end{matrix}$ | 13<br>[0.512] | 20<br>[0.787] | 8<br>[0.28]  |
| <b>R-RAF25</b> | 19g6 $\begin{matrix} -0.007 \\ -0.020 \\ -0.00028 \\ -0.00079 \end{matrix}$ | 15<br>[0.591] | 22<br>[0.866] | 9<br>[0.32]  |
| <b>R-RAF30</b> | 23g6 $\begin{matrix} -0.007 \\ -0.020 \\ -0.00028 \\ -0.00079 \end{matrix}$ | 19<br>[0.748] | 26<br>[1.024] | 11<br>[0.39] |
| <b>R-RAF50</b> | 23g6 $\begin{matrix} -0.007 \\ -0.020 \\ -0.00028 \\ -0.00079 \end{matrix}$ | 19<br>[0.748] | 26<br>[1.024] | 11<br>[0.39] |
| <b>R-RAF70</b> | 26g6 $\begin{matrix} -0.007 \\ -0.020 \\ -0.00028 \\ -0.00079 \end{matrix}$ | 22<br>[0.866] | 29<br>[1.142] | 13<br>[0.46] |

●Spacer for cross roller bearing

SP-RAF10 (Mass 18 g [0.63 oz])

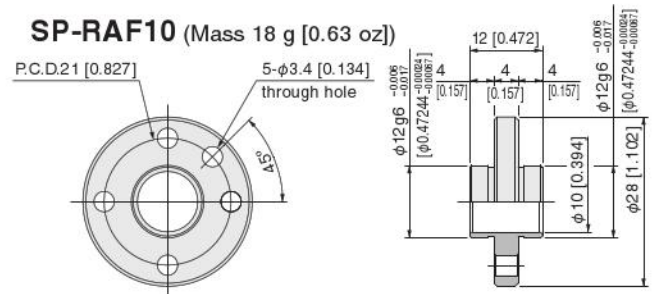

SP-RAF20, 25, 30, 50, 70

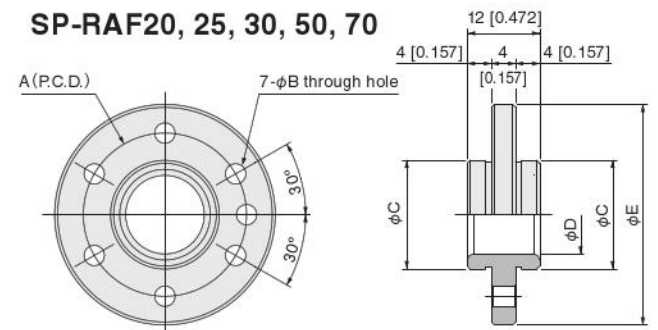

| Model           | A             | B              | C   | D             | E               | Mass g [oz.] |
|-----------------|---------------|----------------|---|---------------|-----------------|--------------|
| <b>SP-RAF20</b> | 27<br>[1.063] | 3.4<br>[0.134] | 18g6 $\begin{matrix} -0.008 \\ -0.017 \\ -0.00024 \\ -0.00067 \end{matrix}$ | 13<br>[0.512] | 36.5<br>[1.437] | 34<br>[1.20] |
| <b>SP-RAF25</b> | 30<br>[1.181] | 4.5<br>[0.177] | 19g6 $\begin{matrix} -0.007 \\ -0.020 \\ -0.00028 \\ -0.00079 \end{matrix}$ | 15<br>[0.591] | 40.5<br>[1.594] | 38<br>[1.34] |
| <b>SP-RAF30</b> | 34<br>[1.339] | 4.5<br>[0.177] | 23g6 $\begin{matrix} -0.007 \\ -0.020 \\ -0.00028 \\ -0.00079 \end{matrix}$ | 19<br>[0.748] | 47<br>[1.850]   | 50<br>[1.76] |
| <b>SP-RAF50</b> | 38<br>[1.496] | 5.5<br>[0.217] | 25g6 $\begin{matrix} -0.007 \\ -0.020 \\ -0.00028 \\ -0.00079 \end{matrix}$ | 19<br>[0.748] | 50.5<br>[1.988] | 61<br>[2.15] |
| <b>SP-RAF70</b> | 42<br>[1.654] | 5.5<br>[0.217] | 29g6 $\begin{matrix} -0.007 \\ -0.020 \\ -0.00028 \\ -0.00079 \end{matrix}$ | 22<br>[0.866] | 57<br>[2.244]   | 79<br>[2.79] |

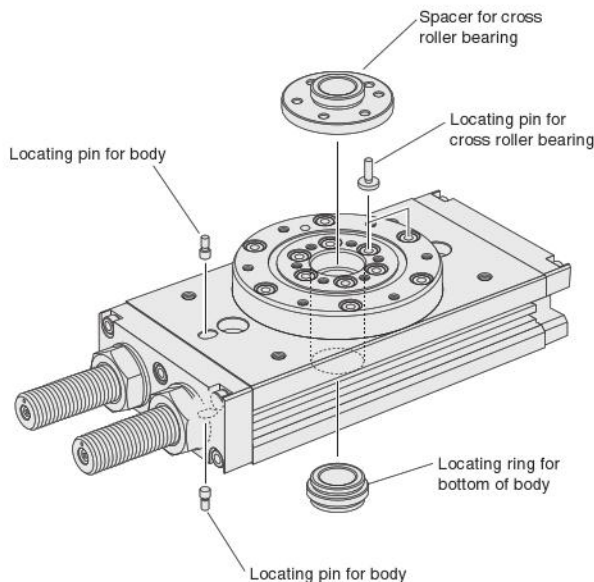

# Sensor Switches

Solid state type, Reed switch type

## Specifications

### ● Solid state type

| Item \ Model                            | ZE135□   | ZE155□   | ZE235□   | ZE255□   | ZE175□                           | ZE275□                |
|---|--|--|--|--|----------------------------------|-----------------------|
| Wiring type                             | 2-lead wire  | 3-lead wire with NPN output                        | 2-lead wire  | 3-lead wire with NPN output                        | 3-lead wire with PNP output      |                       |
| Lead wire direction                     | Horizontal   |  |  | Vertical   |                                  | Horizontal / Vertical |
| Power supply voltage                    | —  | 4.5~28VDC  | —  | 4.5~28VDC  |                                  |                       |
| Load voltage                            | 10~28VDC   | 4.5~28VDC  | 10~28VDC   | 4.5~28VDC  |                                  |                       |
| Load current                            | 4~20 mA at 25°C [77°F],<br>and 10 mA at 60°C [140°F]   | 50 mA MAX.   | 4~20 mA at 25°C [77°F],<br>and 10 mA at 60°C [140°F] | 50 mA MAX.   |                                  |                       |
| Consumption current                     | —  | 8 mA MAX. (24VDC)                                  | —  | 8 mA MAX. (24VDC)                                  | 10 mA MAX. (24VDC)               |                       |
| Internal voltage drop <sup>Note 1</sup> | 4V MAX.  | 0.5V MAX. (10V or less at 20 mA)                   | 4V MAX.  | 0.5V MAX. (10V or less at 20 mA)                   | 0.5V MAX. (10V or less at 20 mA) |                       |
| Leakage current                         | 0.7 mA MAX.<br>(24VDC, 25°C [77°F])  | 50 μA MAX. (24VDC)                                 | 0.7 mA MAX.<br>(24VDC, 25°C [77°F])                  | 50 μA MAX. (24VDC)                                 | 50 μA MAX. (24VDC)               |                       |
| Response time                           | 1 ms MAX   |  |  |  |                                  |                       |
| Insulation resistance                   | 100 MΩ MIN. (at 500VDC Megger, between case and lead wire terminal)  |  |  |  |                                  |                       |
| Dielectric strength                     | 500VAC (50/60 Hz) in 1 minute (between case and lead wire terminal)  |  |  |  |                                  |                       |
| Shock resistance <sup>Note 2</sup>      | 294.2 m/s <sup>2</sup> [30G] (non-repeated)  |  |  |  |                                  |                       |
| Vibration resistance <sup>Note 2</sup>  | 88.3 m/s <sup>2</sup> [9G] (total amplitude of 1.5 mm [0.059 in.], 10~55 Hz)   |  |  |  |                                  |                       |
| Environmental protection                | IEC IP67, JIS C0920 (watertight type)  |  |  |  |                                  |                       |
| Operating indicator                     | When ON, Red LED indicator lights up   |  |  |  |                                  |                       |
| Lead wire <sup>Note 3</sup>             | PCCV 0.2 SQ × 2-lead (brown and blue) × ℓ  | PCCV 0.15 SQ × 3-lead (brown, blue, and black) × ℓ | PCCV 0.2 SQ × 2-lead (brown and blue) × ℓ            | PCCV 0.15 SQ × 3-lead (brown, blue, and black) × ℓ |                                  |                       |
| Ambient temperature                     | 0°~60°C [32°~140°F]  |  |  |  |                                  |                       |
| Storage temperature range               | -10°~70°C [14°~158°F]  |  |  |  |                                  |                       |
| Weight                                  | 15 g [0.53 oz.] (for lead wire length A: 1000 mm [39 in.]), 35 g [1.23 oz.] (for lead wire length B: 3000 mm [118 in.]), 15 g [0.53 oz.] (for lead wire length G: 300 mm [11.8 in.] with M8 connector) |  |  |  |                                  |                       |

\*1: Internal voltage drop changes with the load current.

\*2: According to KOGANEI test standards.

\*3: Lead wire length ℓ : A; 1000 mm [39 in.], B; 3000 mm [118 in.], G; 300 mm [11.8 in.] with M8 connector only for the ZE175□ and ZE275□.

### ● Reed switch type

| Item \ Model                            | ZE101□  | ZE102□                               | ZE201□    | ZE202□                                  |
|---|---|--------------------------------------|-----------|---|
| Wiring type                             | 2-lead wire   |                                      |           |   |
| Lead wire direction                     | Horizontal  |                                      | Vertical  |   |
| Load voltage                            | 5~28VDC   | 85~115VAC (r.m.s.)                   | 10~28VDC  | 85~115VAC (r.m.s.)                      |
| Load current                            | 40 mA MAX.  | 20 mA MAX.                           | 5~40 mA   | 5~20 mA                                 |
| Internal voltage drop <sup>Note 1</sup> | 0.1V MAX. (at load current of DC 40 mA)   |                                      | 3.0V MAX. | 0.1V MAX. (at load current of DC 40 mA) |
| Leakage current                         | 0 mA  |                                      |           |   |
| Response time                           | 1 ms MAX.   |                                      |           |   |
| Insulation resistance                   | 100 MΩ MIN. (at 500VDC Megger, between case and lead wire terminal)   |                                      |           |   |
| Dielectric strength                     | 1500VAC (50/60 Hz) in 1 minute (between case and lead wire terminal)  |                                      |           |   |
| Shock resistance <sup>Note 2</sup>      | 294.2 m/s <sup>2</sup> [30G] (non-repeated)   |                                      |           |   |
| Vibration resistance <sup>Note 2</sup>  | 88.3 m/s <sup>2</sup> [9G] (total amplitude of 1.5 mm [0.059 in.], 10~55 Hz), resonance frequency 2750 ± 250 Hz         |                                      |           |   |
| Environmental protection                | IP67 (IEC standard), JIS C0920 (watertight type)  |                                      |           |   |
| Operating indicator                     | None  | When ON, Red LED indicator lights up | None      | When ON, Red LED indicator lights up    |
| Lead wire                               | PCCV 0.2 SQ × 2-lead (brown and blue) × ℓ <sup>Note 3</sup>   |                                      |           |   |
| Ambient temperature                     | 0°~60°C [32°~140°F]   |                                      |           |   |
| Storage temperature range               | -10°~70°C [14°~158°F]   |                                      |           |   |
| Contact protection measure              | Required (see page 20 under contact protection.)  |                                      |           |   |
| Weight                                  | 15 g [0.53 oz.] (for lead wire length A: 1000 mm [39 in.]), 35 g [1.23 oz.] (for lead wire length B: 3000 mm [118 in.]) |                                      |           |   |

\*1: Internal voltage drop changes with the load current.

\*2: According to KOGANEI test standards.

\*3: Lead wire length ℓ : A; 1000 mm [39 in.], B; 3000 mm [118 in.].

# Order codes for sensor switches only

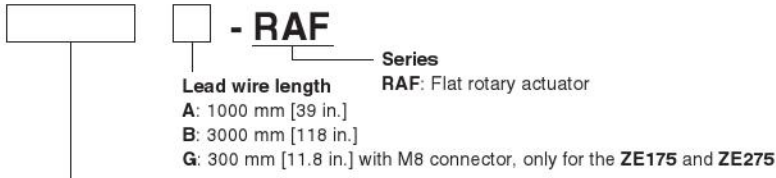

## Sensor switch model

|   |                          |                      |   |           |                      |
|---|--------------------------|----------------------|---|-----------|----------------------|
| <b>ZE135:</b> Solid state type, 2-lead wire                 | with indicator 10~28VDC  | Horizontal lead wire | <b>ZE101:</b> Reed switch type, without indicator | 5~28VDC   | Horizontal lead wire |
| <b>ZE155:</b> Solid state type, 3-lead wire with NPN output | with indicator 4.5~28VDC | Horizontal lead wire |   | 85~115VAC | Horizontal lead wire |
| <b>ZE175:</b> Solid state type, 3-lead wire with PNP output | with indicator 4.5~28VDC | Horizontal lead wire | <b>ZE102:</b> Reed switch type, with indicator    | 10~28VDC  | Horizontal lead wire |
| <b>ZE235:</b> Solid state type, 2-lead wire                 | with indicator 10~28VDC  | Vertical lead wire   |   | 85~115VAC | Horizontal lead wire |
| <b>ZE255:</b> Solid state type, 3-lead wire with NPN output | with indicator 4.5~28VDC | Vertical lead wire   | <b>ZE201:</b> Reed switch type, without indicator | 5~28VDC   | Vertical lead wire   |
| <b>ZE275:</b> Solid state type, 3-lead wire with PNP output | with indicator 4.5~28VDC | Vertical lead wire   |   | 85~115VAC | Vertical lead wire   |
|   |                          |                      | <b>ZE202:</b> Reed switch type, with indicator    | 10~28VDC  | Vertical lead wire   |
|   |                          |                      |   | 85~115VAC | Vertical lead wire   |

## Inner circuit diagrams

### ● Solid State Type

#### ●ZE135□, ZE235□ LED indicator

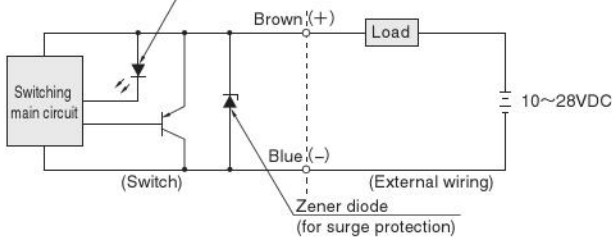

#### ●ZE155□, ZE255□

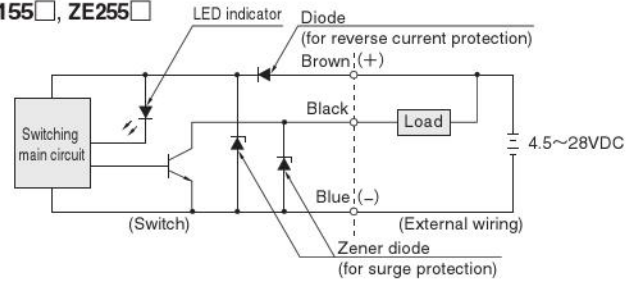

#### ●ZE175□, ZE275□

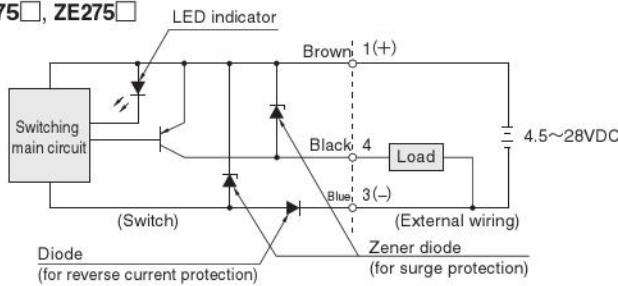

### ● Reed Switch Type

#### ●ZE101□, ZE201□

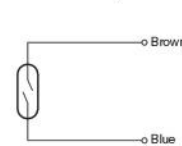

#### ●ZE102□, ZE202□

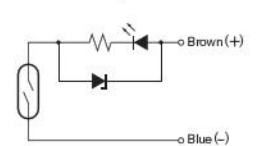

## Sensor switch dimensions mm [in.]

### ●Horizontal lead wire

#### ●Solid state (ZE135□, ZE155□, ZE175□)

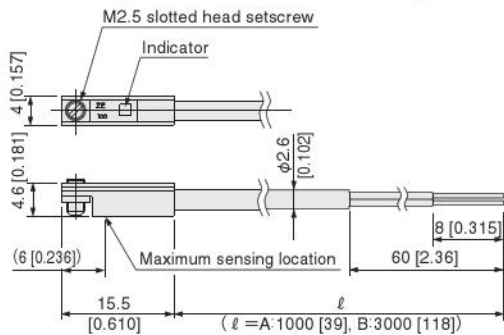

#### ●Reed switch type (ZE101□, ZE102□)

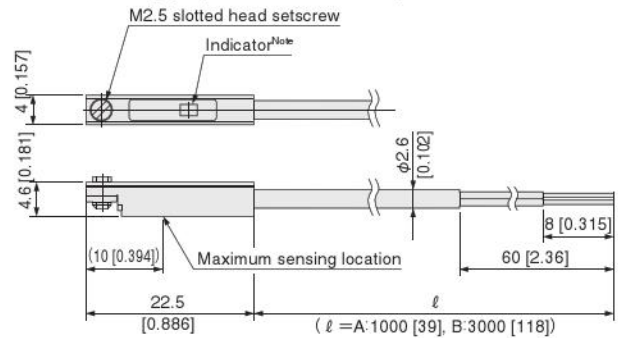

#### ●Solid state (ZE175G)

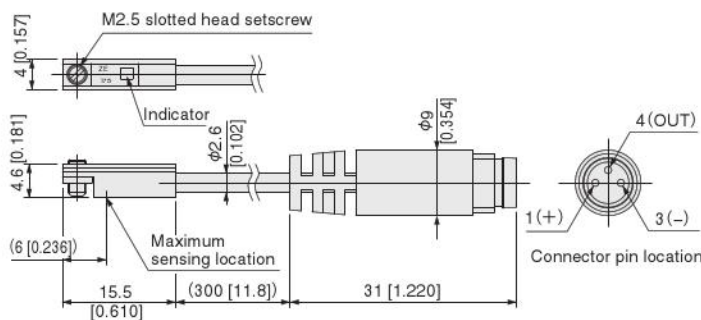

Note: Not available with the ZE101□.

●Vertical lead wire

●Solid state (ZE235□, ZE255□, ZE275□)

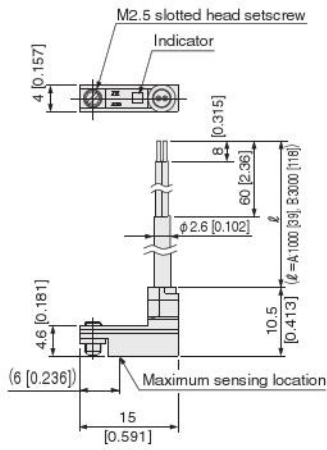

●Solid state (ZE275G)

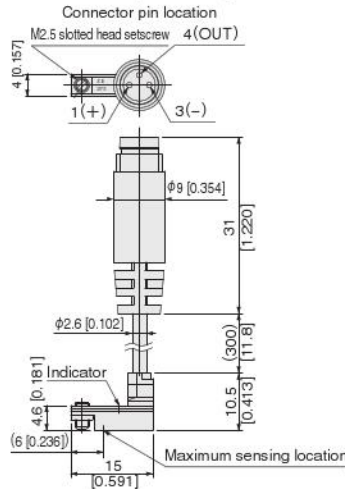

●Reed switch type (ZE201□, ZE202□)

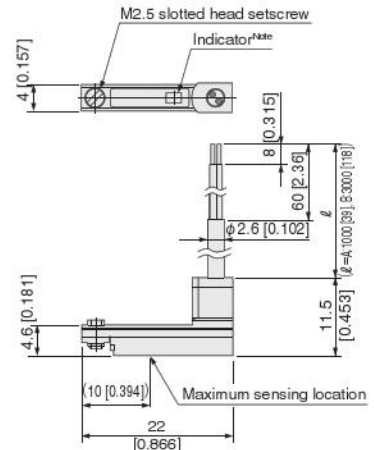

Note: Not available with the ZE201.

Wiring instructions for the solid state sensor switches

●2-lead wire type

●Basic connection

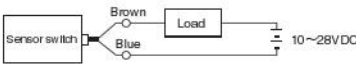

●Connecting with relays

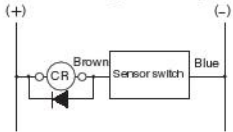

AND (series) connection and OR (parallel) connection

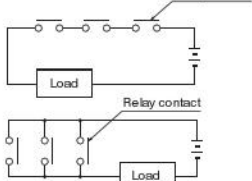
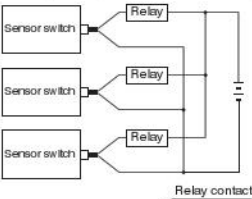

●Connecting with a solenoid valve

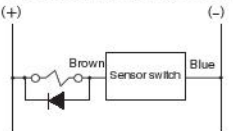

●Connecting with a programmable controller

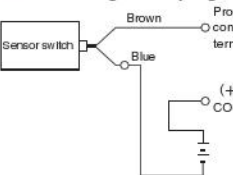

●3-lead wire with NPN output type

●Basic connection

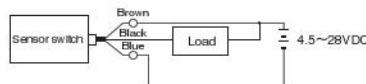

●Connecting with relays

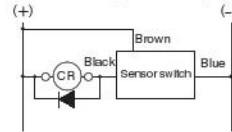

AND (series) connection and OR (parallel) connection

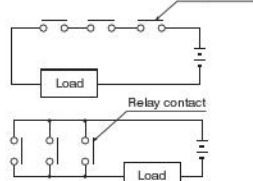
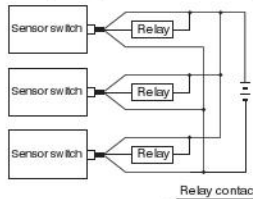

●Connecting with a solenoid valve

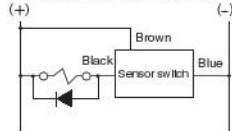

●Connecting with a programmable controller

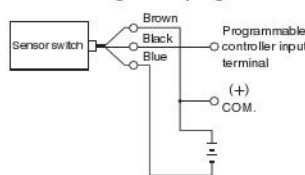

●3-lead wire with PNP output type

●Basic connection

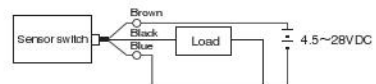

●Connecting with relays

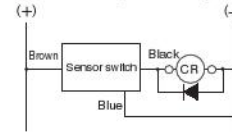

AND (series) connection and OR (parallel) connection

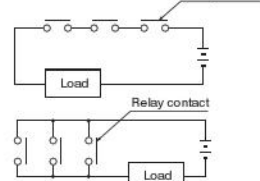
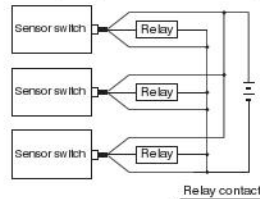

●Connecting with a solenoid valve

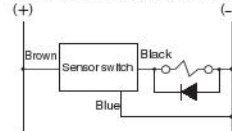

●Connecting with a programmable controller

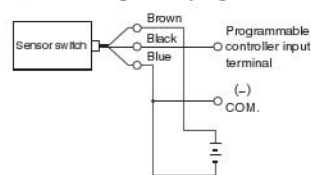

1. Connect the lead wires according to their color. Incorrect wiring will cause damage to the sensor switch since there is no overcurrent protection.
2. The use of a surge protection diode is recommended for the inductive load such as electromagnet relays.
3. Avoid the use of AND (series) connections because the circuit voltage will drop in proportion to the number of sensor switches.
4. When using an OR (parallel) connection, it is possible to connect sensor switch outputs directly (ex: connecting corresponding black lead wires). Be aware of load return errors since current leakage increases with the number of sensor switches.

5. Because the sensor switches are magnetically sensitive, avoid using them in locations subject to strong external magnetic fields or bringing them in close proximity to power lines and areas where large electric currents are present. In addition, do not use magnetized materials for the mounting bracket. Doing so may cause erratic operation.
6. Do not excessively pull on or bend the lead wires.
7. Avoid using the switches in environments where chemicals or gas are present.
8. Consult us for use in environments subject to water or oil.

## Contact protection for reed switch type sensor switch

In order to use the reed switch type sensor switch safely, take the contact protection measures listed below.

### ● For connecting an inductive load (electromagnetic relay etc.) ● For capacitive surges

(When the lead wire length exceeds 10 m [32.80 ft])

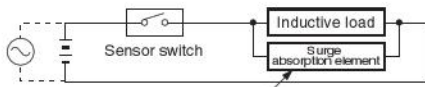

For DC ..... Diode or CR, etc.

For AC ..... CR etc.

Diode: Forward current should be more than the circuit current and the inverse voltage should be 10 times greater or more than the circuit voltage.

C: 0.01~0.1  $\mu$ F  
R: 1~4 k $\Omega$

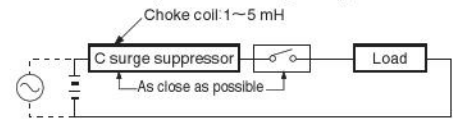

## Moving sensor switch

- Loosening the screw allows the sensor switch to be moved along the switch mounting groove of the flat rotary actuator.
- The tightening torque for the screws is 0.1 N·m~0.2 N·m [0.9 in·lbf~1.8 in·lbf].

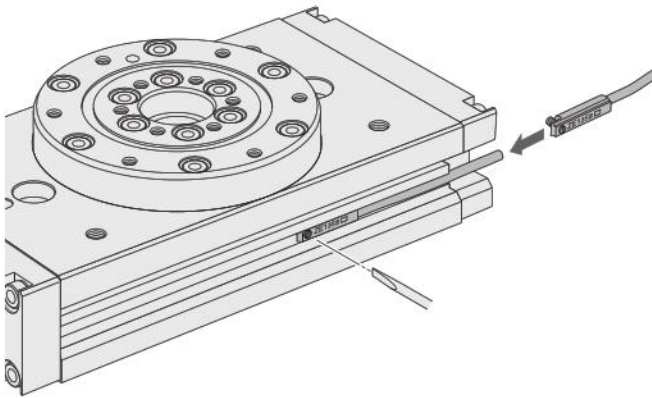

## When mounting the cylinders with sensor switches in close proximity

When mounting flat rotary actuators with sensor switches in close proximity or side by side, install them using a value greater than those shown in the table below.

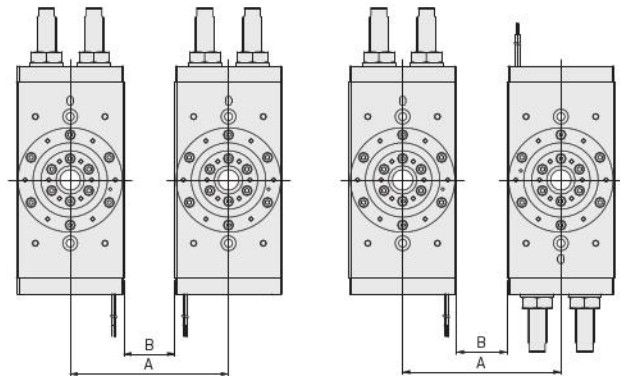

| Model       | Solid State Type |            | Reed Switch Type |            |
|-------------|------------------|------------|------------------|------------|
|             | A                | B          | A                | B          |
| RAF10-180-□ | 68 [2.678]       | 10 [0.394] | 68 [2.678]       | 10 [0.394] |
| RAF20-180-□ | 78 [3.071]       |            | 78 [3.071]       |            |
| RAF25-180-□ | 88 [3.465]       |            | 88 [3.465]       |            |
| RAF30-180-□ | 92 [3.622]       |            | 92 [3.622]       |            |
| RAF50-180-□ | 100 [3.937]      |            | 100 [3.937]      |            |
| RAF70-180-□ | 110 [4.331]      |            | 110 [4.331]      |            |

## Sensor switch operating range, response differential, and maximum sensing location

### ● Operating range: $\ell$

The distance the rack travels in one direction, while the sensor switch is ON.

### ● Response differential: C

The distance between the rack where the rack turns the switch ON and the point where the switch is turned OFF as the rack travels in the opposite direction.

### ● Solid state type

| Item                                     | Model | RAF10                 | RAF20 | RAF25 | RAF30 | RAF50 | RAF70 |
|--|-------|-----------------------|-------|-------|-------|-------|-------|
| Operating range: $\ell$                  |       | 2.0~6.0 [0.079~0.236] |       |       |       |       |       |
| Response differential: C                 |       | 1.0 [0.039] or less   |       |       |       |       |       |
| Maximum sensing location <sup>Note</sup> |       | 6 [0.236]             |       |       |       |       |       |

Remark: The values in the table above are reference values.

Note: The value from the opposite end to the lead wire.

### ● Reed switch type

| Item                                     | Model | RAF10                 | RAF20 | RAF25 | RAF30 | RAF50 | RAF70 |
|--|-------|-----------------------|-------|-------|-------|-------|-------|
| Operating range: $\ell$                  |       | 4.5~8.5 [0.177~0.335] |       |       |       |       |       |
| Response differential: C                 |       | 1.5 [0.059] or less   |       |       |       |       |       |
| Maximum sensing location <sup>Note</sup> |       | 10 [0.394]            |       |       |       |       |       |

Remark: The values in the table above are reference values.

Note: The value from the opposite end to the lead wire.

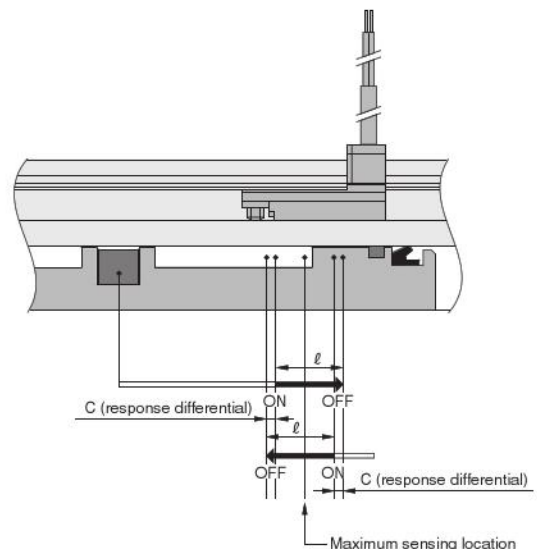

# Swinging end detection sensor switch mounting position

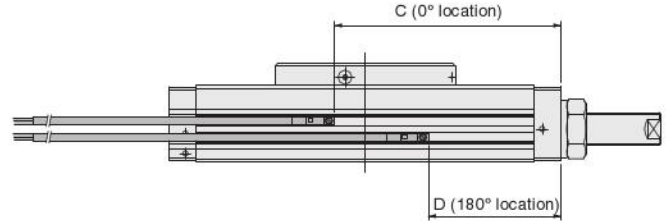
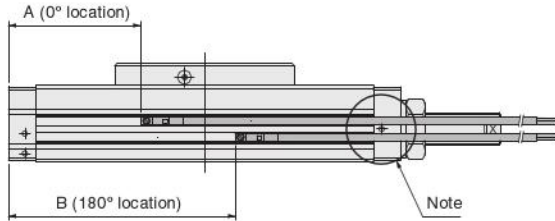
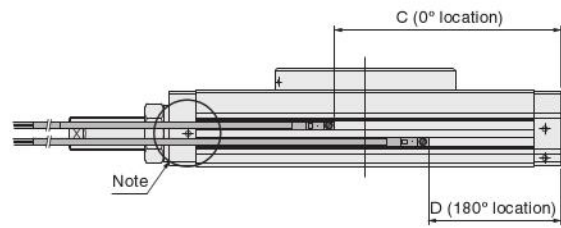
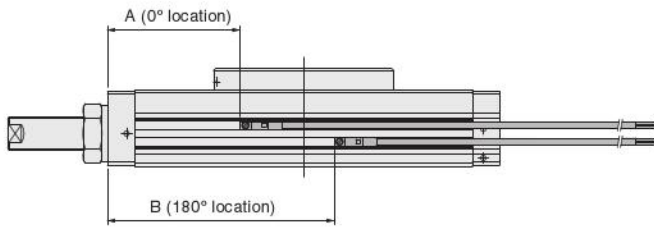

● **Solid state type (ZE135, ZE155, ZE175, ZE235, ZE255, ZE275)** mm [in.]

| Model       | A            | B             | C             | D            |
|-------------|--------------|---------------|---------------|--------------|
| RAF10-180-□ | 41.1 [1.618] | 68.9 [2.713]  | 68.9 [2.713]  | 41.1 [1.618] |
| RAF20-180-□ | 48.7 [1.917] | 83.3 [3.280]  | 83.3 [3.280]  | 48.7 [1.917] |
| RAF25-180-□ | 53.4 [2.102] | 92.6 [3.646]  | 92.6 [3.646]  | 53.4 [2.102] |
| RAF30-180-□ | 60.5 [2.382] | 107.5 [4.232] | 107.5 [4.232] | 60.5 [2.382] |
| RAF50-180-□ | 65.3 [2.571] | 114.7 [4.516] | 114.7 [4.516] | 65.3 [2.571] |
| RAF70-180-□ | 72.7 [2.862] | 129.3 [5.091] | 129.3 [5.091] | 72.7 [2.862] |

Note: Be aware that, for horizontal lead wire types as shown in the following diagram, the lead wire protrudes from the side of the body if the sensor switch's lead wire is run from the shock absorber side. If there is a possibility of the lead wire coming into contact with anything where it protrudes, use a design that allows the lead wires to come out on the piping side.

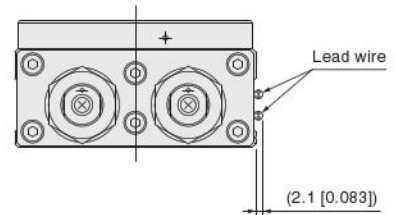

● **Reed switch type (ZE101, ZE102, ZE201, ZE202)** mm [in.]

| Model       | A            | B             | C             | D            |
|-------------|--------------|---------------|---------------|--------------|
| RAF10-180-□ | 37.1 [1.461] | 64.9 [2.555]  | 64.9 [2.555]  | 37.1 [1.461] |
| RAF20-180-□ | 44.7 [1.760] | 79.3 [3.122]  | 79.3 [3.122]  | 44.7 [1.760] |
| RAF25-180-□ | 49.4 [1.945] | 88.6 [3.488]  | 88.6 [3.488]  | 49.4 [1.945] |
| RAF30-180-□ | 56.5 [2.224] | 103.5 [4.075] | 103.5 [4.075] | 56.5 [2.224] |
| RAF50-180-□ | 61.3 [2.413] | 110.7 [4.358] | 110.7 [4.358] | 61.3 [2.413] |
| RAF70-180-□ | 68.7 [2.705] | 125.3 [4.933] | 125.3 [4.933] | 68.7 [2.705] |

## Reed switch type sensor switch allowable swing time

Use a solid state sensor switch for low speed applications. The allowable swing time when using a reed switch type sensor switch are shown below.

| Model       | Time    |
|-------------|---------|
| RAF10-180-□ | 0.2~0.4 |
| RAF20-180-□ | 0.2~0.5 |
| RAF25-180-□ | 0.2~0.6 |
| RAF30-180-□ | 0.2~0.7 |
| RAF50-180-□ | 0.2~0.8 |
| RAF70-180-□ | 0.2~0.9 |

s/90°

# Limited Warranty

KOGANEI CORP. warrants its products to be free from defects in material and workmanship subject to the following provisions.

**Warranty Period** The warranty period is 180 days from the date of delivery.

**Koganei Responsibility** If a defect in material or workmanship is found during the warranty period, KOGANEI CORP. will replace any part proved defective under normal use free of charge and will provide the service necessary to replace such a part.

**Limitations**

- This warranty is in lieu of all other warranties, expressed or implied, and is limited to the original cost of the product and shall not include any transportation fee, the cost of installation or any liability for direct, indirect or consequential damage or delay resulting from the defects.

- KOGANEI CORP. shall in no way be liable or responsible for injuries or damage to persons or property arising out of the use or operation of the manufacturer's product.

- This warranty shall be void if the engineered safety devices are removed, made inoperative or not periodically checked for proper functioning.

- Any operation beyond the rated capacity, any improper use or application, or any improper installation of the product, or any substitution upon it with parts not furnished or approved by KOGANEI CORP., shall void this warranty.

- This warranty covers only such items supplied by KOGANEI CORP. The products of other manufacturers are covered only by such warranties made by those original manufacturers, even though such items may have been included as the components.

The specifications are subject to change without notice.

ISO9001  
ISO14001



- ISO 9001 certified offices are Main Office, Tokyo Plant, Komagane Plant, and Sales Offices.

- ISO 14001 certified offices are Main Office, Tokyo Plant, and Komagane Plant.

URL <http://www.koganei.co.jp>

E-mail: [overseas@koganei.co.jp](mailto:overseas@koganei.co.jp)



## KOGANEI CORPORATION

### OVERSEAS DEPARTMENT

3-11-28, Midori-cho, Koganei City, Tokyo 184-8533, Japan  
Tel: 042-383-7271 Fax: 042-383-7276

### SHANGHAI KOGANEI INTERNATIONAL TRADING CORPORATION

Room 2606-2607, Tongda Venture Building No.1, Lane 600, Tianshan Road, Shanghai, 200051, China  
Tel: 021-6145-7313 Fax: 021-6145-7323

### KOGANEI-PORNCHAI CO., LTD.

89/174 Moo 3, Vibhavadee Rangsit Road, Talad Bangkhen, Laksi, Bangkok, 10210, Thailand  
Tel: 02-551-4025 Fax: 02-551-4015