

TS/ATS Straight

● Existing model TS

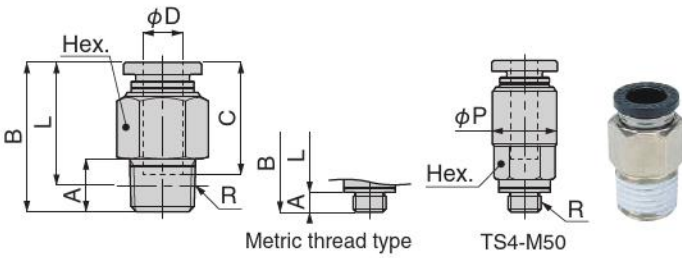

● New model ATS

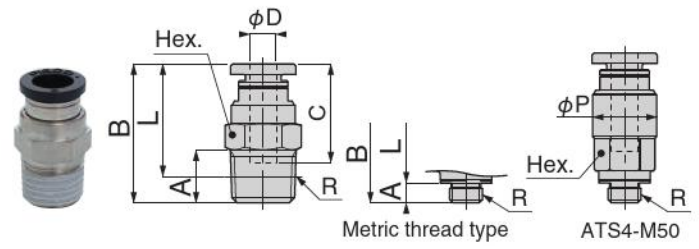

■ indicates portion of new models (new shapes) that have changed in dimension.

Unit: mm

Model	Tube outer diameter ϕD	R	A	B	L	C	Width across flats Hex.	ϕP	Orifice diameter (ϕ type)	Mass g [oz]
TS4-M5-D	4	M5×0.8	3	20	17	14.9	10	-	1.8	6.3 [0.22]
ATS4-M5-D			2.8	19.8					2.4	5.6 [0.2]
TS4-M50-□	4	M5×0.8	3	22.9	19.9	14.9	8	9.7	1.8	6.6 [0.23]
ATS4-M50-□			2.8	22.7					2.4	6.1 [0.22]
TS4-M6-D	4	M6×1	4	21	17	14.9	10	-	3	6.4 [0.23]
ATS4-M6-D			3.8	20.8					6	0.21
TS4-01-D	4	R1/8	8	21	17	14.9	10	-	3	8.3 [0.29]
ATS4-01-D			7.4	0.26						
TS4-02-□	4	R1/4	11	21	15	14.9	14	-	3	16 [0.56]
ATS4-02-□			22.5	16.5						
TS6-M5-D	6	M5×0.8	3	22.1	19.1	17	12	-	1.8	9.2 [0.32]
ATS6-M5-D			2.8	21.9					2.4	8.1 [0.29]
TS6-M6-D	6	M6×1	4	23.1	19.1	17	12	-	3	9.4 [0.33]
ATS6-M6-D			3.8	22.9					8.5	0.3
TS6-01-D	6	R1/8	8	22.6	18.6	17	12	-	4.6	9.3 [0.33]
ATS6-01-D			22.3	18.3	5				8.2 [0.29]	
TS6-02-□	6	R1/4	11	24.6	18.5	17	14	-	4.6	18 [0.63]
ATS6-02-□			23.7	17.6	5				15 [0.53]	
TS6-03-□	6	R3/8	12	23.6	17.2	17	17	-	4.6	28 [0.99]
ATS6-03-□			24.5	18.1	5					
TS8-01-□	8	R1/8	8	27.9	23.9	18.2	14	-	6	16 [0.56]
ATS8-01-□			14	0.49						
TS8-02-□	8	R1/4	11	26.6	20.6	18.2	14	-	7	16 [0.56]
ATS8-02-□			14	0.49						
TS8-03-□	8	R3/8	12	23.9	17.6	18.2	17	-	7	24 [0.85]
ATS8-03-□			25.5	19.2	25				0.88	
TS10-01-□	10	R1/8	8	30.3	26.3	20.7	17	-	6	24 [0.85]
ATS10-01-□			21	0.74						
TS10-02-□	10	R1/4	11	29.8	23.8	20.7	17	-	8.5	21 [0.74]
ATS10-02-□			19	0.67						
TS10-03-□	10	R3/8	12	29.3	23	20.7	17	-	8.5	27 [0.95]
ATS10-03-□			9	24 [0.85]						
TS10-04-□	10	R1/2	15	30.3	22.1	20.7	21	-	8.5	50 [1.76]
ATS10-04-□			30.4	22.2	9				46 [1.62]	
TS12-02-□	12	R1/4	11	35.9	29.9	23.3	21	-	8.5	44 [1.55]
ATS12-02-□			37	1.31						
TS12-03-□	12	R3/8	12	31.9	25.6	23.3	21	-	11	36 [1.27]
ATS12-03-□			30	1.06						
TS12-04-□	12	R1/2	15	33.9	25.7	23.3	21	-	11	50 [1.76]
ATS12-04-□			44	1.55						
TS16-03-□	16	R3/8	12	39.3	33	24.8	24	-	11	58 [2.05]
ATS16-03-□			54	1.9						
TS16-04-□	16	R1/2	15	41.3	33.1	24.8	24	-	13	66 [2.33]
ATS16-04-□			63	2.22						

* -D ⇒ Non-lubricant specification only. -□ ⇒ Select either blank (standard) or D (non-lubricant specification)

* The L dimension for the tapered thread types is a reference dimension when mated and tightened.

* Prices are the same.

TSH/ATSH Straight with hexagon socket

● Existing model **TSH**

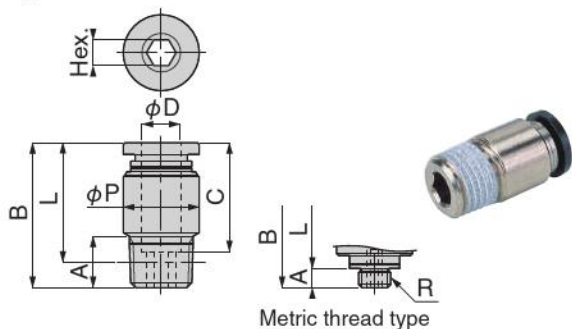

● New model **ATSH**

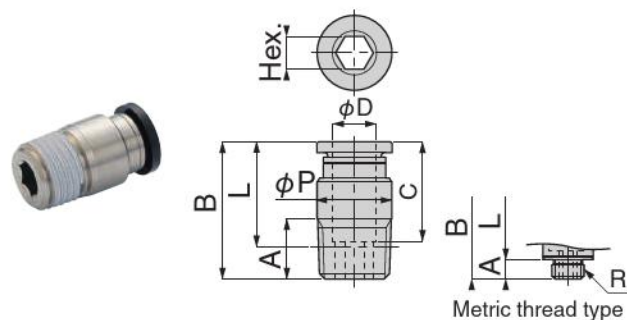

Unit: mm

Model	Tube outer diameter φD	R	A	B	L	C	Width across flats Hex.	φP	Orifice diameter (φ mm)	Mass g [oz]
TSH4-M5-D	4	M5 × 0.8	3	19.9	16.9	14.9	2	9.7	2	5.6 [0.2]
ATSH4-M5-D			2.8	19.7			2.6		4.6 [0.16]	
TSH4-M6-D	4	M6 × 1	4	20.9	16.9	14.9	3	9.7	3.1	5.9 [0.21]
ATSH4-M6-D			3.8	20.7			2.6		5.4 [0.19]	
TSH4-01-D	4	R1/8	8	21	17	14.9	2.5	9.7	2.6	7.6 [0.27]
ATSH4-01-D				20	16					6.6 [0.23]
TSH6-M5-D	6	M5 × 0.8	3	23	20	17	2	11.8	2	8.5 [0.3]
ATSH6-M5-D			2.8	21.3			18.5		2.6	5.6 [0.2]
TSH6-M6-D	6	M6 × 1	4	22.5	18.5	17	3	11.8	3.2	6.9 [0.24]
ATSH6-M6-D			3.8	22.3			18.5		3	6.3 [0.22]
TSH6-01-D	6	R1/8	8	22.6	18.6	17	4	11.8	4.2	8.1 [0.29]
ATSH6-01-D				22.1	18.1					7.6 [0.27]
TSH6-02-□	6	R1/4	11	22.6	16.5	17	4	14	4.2	15 [0.53]
ATSH6-02-□				21.3	15.2			13.7		13 [0.46]
TSH8-01-□	8	R1/8	8	27.9	23.9	18.2	5	13.7	5.3	14 [0.49]
ATSH8-01-□				25.9	21.9					8.8 [0.31]
TSH8-02-□	8	R1/4	11	26.6	20.6	18.2	6	13.7	6.3	15 [0.53]
ATSH8-02-□				25.1	19.1					13 [0.46]
TSH8-03-□	8	R3/8	12	23.9	17.6	18.2	6	16.8	6.3	23 [0.81]
ATSH8-03-□				22.2	15.9					19 [0.67]
TSH10-02-□	10	R1/4	11	29.8	23.8	20.7	6	17.7	6.3	23 [0.81]
ATSH10-02-□								17.5		20 [0.71]
TSH10-03-□	10	R3/8	12	29.3	23	20.7	6	17.7	6.3	28 [0.99]
ATSH10-03-□								17.5		26 [0.92]
TSH10-04-□	10	R1/2	15	30.3	22.1	20.7	6	20.8	6.3	49 [1.73]
ATSH10-04-□										45 [1.59]
TSH12-03-□	12	R3/8	12	31.9	25.6	23.3	8	20.8	8.4	34 [1.2]
ATSH12-03-□										31 [1.09]
TSH12-04-□	12	R1/2	15	33.9	25.7	23.3	8	20.8	8.4	49 [1.73]
ATSH12-04-□										45 [1.59]

Changed width across flats of inner diameter of hex nut and diameter of orifice to correct the problem of lock hook interference with hex wrench.

* -D ⇒ Non-lubricant specification only. -□ ⇒ Select either blank (standard) or D (non-lubricant specification)

* The L dimension for the tapered thread types is a reference dimension when mated and tightened.

* Prices are the same.

TSM/ATSM Female straight

● Existing model **TSM**

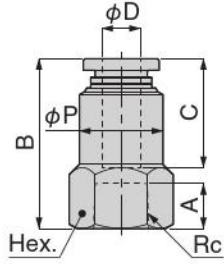

● New model **ATSM**

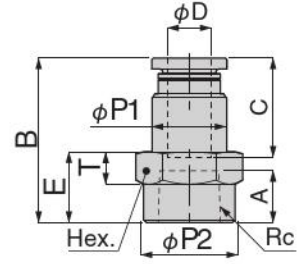

Unit: mm

Model	Tube outer diameter φ D	Rc	A	B	E	φ P1	φ P2	C	Width across flats Hex.	T	Orifice diameter (φ mm)	Mass g [oz]
TSM4-01-□	4	Rc1/8	7	24.4	-	11	-	14.9	14	-	3	16 [0.56]
ATSM4-01-□				23.9	10	9.7	13.8			5		13 [0.46]
TSM4-02-□	4	Rc1/4	9.5	27.4	-	12	-	14.9	17	-	3	24 [0.85]
ATSM4-02-□				26.9	13	9.7	16.8			6		19 [0.67]
TSM6-01-□	6	Rc1/8	7	26.5	-	13	-	17	14	-	4.6	18 [0.63]
ATSM6-01-□				26	10	11.8	13.8			5	5	15 [0.53]
TSM6-02-□	6	Rc1/4	9.5	29.5	-	13	-	17	17	-	4.6	25 [0.88]
ATSM6-02-□				29	13	11.8	16.8			6	5	21 [0.74]
TSM8-01-□	8	Rc1/8	7	28	-	14.5	-	18.2	14	-	6	20 [0.71]
ATSM8-01-□				27.2	10	13.7	13.8			5	7	16 [0.56]
TSM8-02-□	8	Rc1/4	9.5	31	-	15	-	18.2	17	-	6	27 [0.95]
ATSM8-02-□				30.2	13	13.7	16.8			6	7	22 [0.78]
TSM8-03-□	8	Rc3/8	10.5	32	-	15.5	-	18.2	21	-	6	37 [1.31]
ATSM8-03-□				31.2	14	13.7	20.8			6.5	7	30 [1.06]
TSM10-02-□	10	Rc1/4	9.5	33.7	-	17.5	-	20.7	17	-	8.5	33 [1.16]
ATSM10-02-□				32.7	13	17.5	16.8			6	9	28 [0.99]
TSM10-03-□	10	Rc3/8	10.5	34.7	-	17.5	-	20.7	21	-	8.5	42 [1.48]
ATSM10-03-□				33.7	14	17.5	20.8			6.5	9	37 [1.31]
TSM12-02-□	12	Rc1/4	9.5	35.8	-	20.8	-	23.3	21	-	11	57 [2.01]
ATSM12-02-□				34.8	13.5	20.8	16.8			6.5	11	42 [1.48]
TSM12-03-□	12	Rc3/8	10.5	36.8	-	20.8	-	23.3	21	-	11	51 [1.8]
ATSM12-03-□				36.3	14	20.8	20.8			6.5	11	44 [1.55]

* -□ ⇒ Select either blank (standard) or D (non-lubricant specification)

* Prices are the same.

UK/AUK Union for bulkhead

● Existing model **UK**

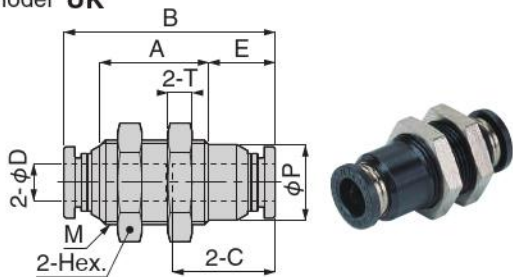

● New model **AUK**

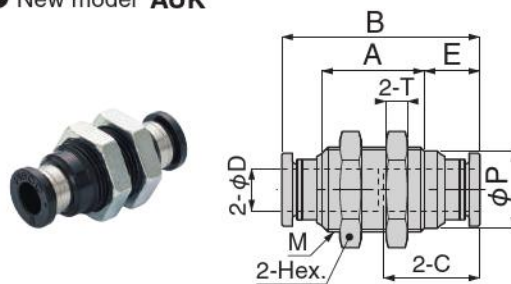

Unit: mm

Model	Tube outer diameter ϕD	M	B	E	A	ϕP	C	Width across flats Hex.	T	Orifice diameter (ϕ mm)	Mass g [oz]
UK4-D	4	M12×1	30.8	10.4	15	10.8	14.9	14	4	3	11 [0.39]
AUK4-D				9.5	14.8						
UK6-D	6	M14×1	34.9	11	18	12.5	17	17	4	4.6	16 [0.56]
AUK6-D				9.5	19					5	
UK8-□	8	M16×1	37.4	14.3	16.8	14.6	18.2	19	4	6	20 [0.71]
AUK8-□				10.5	19.4					7	
UK10-□	10	M20×1	42.4	12.7	23	18.5	20.7	24	5	8	39 [1.38]
AUK10-□				11.9	21.6					9	
UK12-□	12	M22×1	47.6	12.3	29	20.4	23.3	27	6	11	57 [2.01]
AUK12-□				13.2	24.2					11	

* -D ⇒ Non-lubricant specification only. -□ ⇒ Select either blank (standard) or D (non-lubricant specification)

* Prices are the same.

UKM/AUKM Female union for bulkhead

● Existing model **UKM**

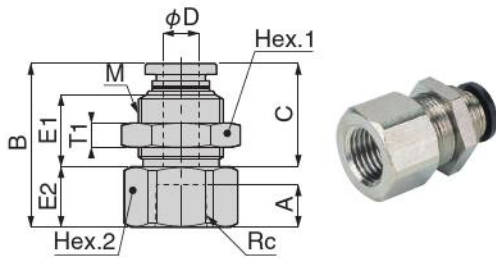

● New model **AUKM**

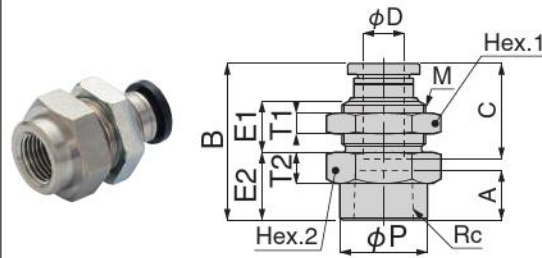

Unit: mm

Model	Tube outer diameter ϕD	Rc	M	B	E1	E2	A	C	ϕP	Width across flats Hex.1	Width across flats Hex.2	T1	T2	Orifice diameter (ϕ mm)	Mass g [oz]
UKM4-01-□	4	Rc1/8	M12×1	24.5	9.9	10	7	14.9	-	14	14	4	-	3	19 [0.67]
AUKM4-01-□				24.2	9	9			13.8				5		17 [0.6]
UKM6-01-□	6	Rc1/8	M14×1	27.1	11.9	10	7	17	-	17	17	4	-	4.6	29 [1.02]
AUKM6-01-□				26.4	10.2				13.8				6		5
UKM6-02-□	6	Rc1/4	M14×1	30.1	11.9	13	9.5	17	-	17	17	4	-	4.6	29 [1.02]
AUKM6-02-□				28.7	10.2	12.3			16.8				6		5
UKM8-01-□	8	Rc1/8	M16×1	29	13.5	10	7	18.2	-	19	19	4	-	6	39 [1.38]
AUKM8-01-□				27	9.8				13.8				6		7
UKM8-02-□	8	Rc1/4	M16×1	32	13.5	13	9.5	18.2	-	19	19	4	-	6	41 [1.45]
AUKM8-02-□				30	9.8				16.8				6		7
UKM8-03-□	8	Rc3/8	M16×1	33	13.5	14	10.5	18.2	-	19	19	4	-	6	35 [1.23]
AUKM8-03-□				31	9.8				19.5				6		7
UKM10-02-□	10	Rc1/4	M20×1	34.8	14.9	14	9.5	20.7	-	24	24	5	-	8.5	78 [2.75]
AUKM10-02-□				32.7	11.1	13			16.8				7		9
UKM10-03-□	10	Rc3/8	M20×1	35.8	14.9	15	10.5	20.7	-	24	24	5	-	8.5	73 [2.57]
AUKM10-03-□				33.7	11.1	14			20.8				7		9
UKM12-03-□	12	Rc3/8	M22×1	38.9	18.4	15	10.5	23.3	-	27	24	6	-	11	86 [3.03]
AUKM12-03-□				36.3	12.4	14			20.8				7		11
UKM12-04-□	12	Rc1/2	M22×1	41.9	18.4	18	13	23.3	-	27	24	6	-	11	80 [2.82]
AUKM12-04-□				39.3	12.4	17			25				7		11

* -□ ⇒ Select either blank (standard) or D (non-lubricant specification)

* Prices are the same.

TL/ATL Elbow

● Existing model **TL**

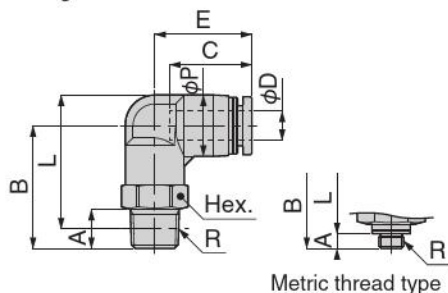

● New model **ATL**

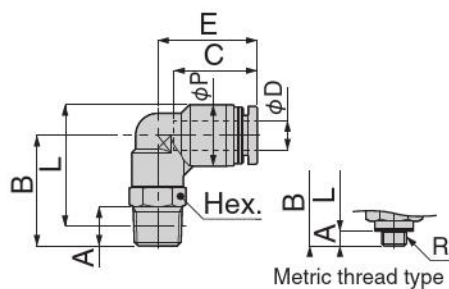

Unit: mm

Model	Tube outer diameter ϕ D	R	A	B	L	ϕ P	C	E	Width across flats Hex.	Orifice diameter (ϕ mm)	Mass g [oz]
TL4-M5-D	4	M5×0.8	3	20.3	22.3	10	14.9	18	10	1.8	8 [0.28]
ATL4-M5-D			2.8	16	18.2			17.7	8	2.4	5.7 [0.2]
TL4-M6-D	4	M6×1	4	21.3	22.3	10	14.9	18	10	2.4	8.3 [0.29]
ATL4-M6-D			3.8	20	21.2			18.7	8 [0.28]		
TL4-01-D	4	R1/8	8	23.3	24.3	10	14.9	18	10	2.8	11 [0.39]
ATL4-01-D			22	23	18.7			10 [0.35]			
TL4-02-□	4	R1/4	11	26.3	25.3	10	14.9	18	14	2.8	21 [0.74]
ATL4-02-□				29	28			20.7			18 [0.63]
TL6-M5-D	6	M5×0.8	3	22	25.3	12.5	16.8	19.8	12	1.8	13 [0.46]
ATL6-M5-D			2.8	19.5	23			17	20.3	10	2.4
TL6-M6-D	6	M6×1	4	23	25.3	12.5	16.8	19.8	12	3	13 [0.46]
ATL6-M6-D			3.8	20.5	23			17	20.3		10
TL6-01-D	6	R1/8	8	25	27.3	12.5	16.8	19.8	12	4.3	14 [0.49]
ATL6-01-D			22.5	24.8	17			20.3	10		11 [0.39]
TL6-02-□	6	R1/4	11	28	28.2	12.5	16.8	19.8	14	4.3	22 [0.78]
ATL6-02-□								17			21.8
TL6-03-□	6	R3/8	12	29.8	29.7	12.5	16.8	19.8	17	4.3	35 [1.23]
ATL6-03-□				31.5	31.4			17			23.8
TL8-01-□	8	R1/8	8	28	31.3	14.5	18.1	22.7	14	6	19 [0.67]
ATL8-01-□				24	27.3				12		14 [0.49]
TL8-02-□	8	R1/4	11	31	32.2	14.5	18.1	22.7	14	6	24 [0.85]
ATL8-02-□				28	29.2			23.7			6.7
TL8-03-□	8	R3/8	12	32.8	33.7	14.5	18.1	22.7	17	6	37 [1.31]
ATL8-03-□				31	31.9			24.7			6.7
TL10-01-□	10	R1/8	8	33	37.8	17.5	20.2	26.2	17	6	31 [1.09]
ATL10-01-□				25	29.8			25.5			12
TL10-02-□	10	R1/4	11	36	38.7	17.5	20.2	26.2	17	8	34 [1.2]
ATL10-02-□				28.5	31.2			26			14
TL10-03-□	10	R3/8	12	37	39.4	17.5	20.2	26.2	17	8	43 [1.52]
ATL10-03-□				32	34.4			27			17
TL10-04-□	10	R1/2	15	40	40.6	17.5	20.2	26.2	21	8	65 [2.29]
ATL10-04-□				36	36.6			27.5			21
TL12-02-□	12	R1/4	11	38	42.5	21	23.4	29.4	21	8	51 [1.8]
ATL12-02-□				29.8	34.2			29			14
TL12-03-□	12	R3/8	12	39	43.2	21	23.4	29.4	21	10	52 [1.83]
ATL12-03-□				32.5	36.7			29.7			17
TL12-04-□	12	R1/2	15	42	44.3	21	23.4	29.4	21	10	67 [2.36]
ATL12-04-□				36.5	38.8			30.7			21

* -D ⇒ Non-lubricant specification only. -□ ⇒ Select either blank (standard) or D (non-lubricant specification)

* The L dimension for the tapered thread types is a reference dimension when mated and tightened.

* Prices are the same.

TLL/ATLL Long elbow

● Existing model TLL

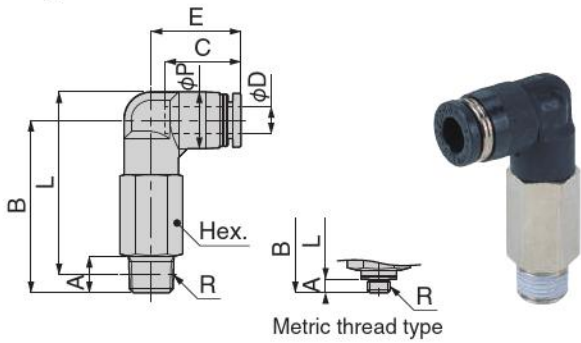

● New model ATLL

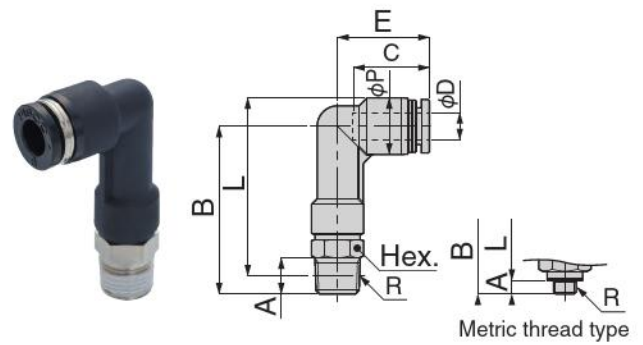

Unit: mm

Model	Tube outer diameter φD	R	A	B	L	φP	C	E	Width across flats Hex.	Orifice diameter (φ mm)	Mass g [oz]
TLL4-M5-D	4	M5×0.8	3	32.3	34.3	10	14.9	18	10	1.8	8.4 [0.3]
ATLL4-M5-D			2.8	28	30.2			18.7	8	2.4	6.4 [0.23]
TLL4-01-D	4	R1/8	8	35.3	36.3	10	14.9	18	10	2.8	17 [0.6]
ATLL4-01-D			34	35	18.7			11 [0.39]			
TLL6-01-D	6	R1/8	8	38	40.3	12.5	16.8	19.8	12	4.3	26 [0.92]
ATLL6-01-D				37	39.3		17	20.3			10
TLL6-02-□	6	R1/4	11	41	41.2	12.5	16.8	19.8	14	4.3	39 [1.38]
ATLL6-02-□				42.5	42.7		17	21.8			20 [0.71]
TLL6-03-□	6	R3/8	12	43.3	43.2	12.5	16.8	19.8	17	4.3	62 [2.19]
ATLL6-03-□				46	45.9		17	23.8			33 [1.16]
TLL8-01-□	8	R1/8	8	43.5	46.8	14.5	18.1	22.7	14	6	37 [1.31]
ATLL8-01-□				40.5	43.8			12			16 [0.56]
TLL8-02-□	8	R1/4	11	46.5	47.7	14.5	18.1	22.7	14	6	43 [1.52]
ATLL8-02-□				44.5	45.7		23.7	6.7		22 [0.78]	
TLL8-03-□	8	R3/8	12	48.3	49.2	14.5	18.1	22.7	17	6	66 [2.33]
ATLL8-03-□				47.5	48.4			24.7		6.7	35 [1.23]
TLL10-02-□	10	R1/4	11	54.5	57.2	17.5	20.2	26.2	17	8	65 [2.29]
ATLL10-02-□				48	50.7		26	14			26 [0.92]
TLL10-03-□	10	R3/8	12	55.5	57.9	17.5	20.2	26.2	17	8	74 [2.61]
ATLL10-03-□				51.5	53.9		27	8.3		38 [1.34]	
TLL10-04-□	10	R1/2	15	60	60.6	17.5	20.2	26.2	21	8	121 [4.27]
ATLL10-04-□				55.5	56.1		27	8.3		63 [2.22]	
TLL12-02-□	12	R1/4	11	60	64.5	21	23.4	29.4	21	8	112 [3.95]
ATLL12-02-□				52.8	57.2		29	14			30 [1.06]
TLL12-03-□	12	R3/8	12	61	65.2	21	23.4	29.4	21	10	107 [3.77]
ATLL12-03-□				55.5	59.7		29.7	17			42 [1.48]
TLL12-04-□	12	R1/2	15	64	66.3	21	23.4	29.4	21	10	123 [4.34]
ATLL12-04-□				59.5	61.8		29.7	10.3		68 [2.4]	

* -D ⇒ Non-lubricant specification only. -□ ⇒ Select either blank (standard) or D (non-lubricant specification)

* The L dimension for the tapered thread types is a reference dimension when mated and tightened.

* Prices are the same.

TT/ATT Tee

● Existing model **TT**

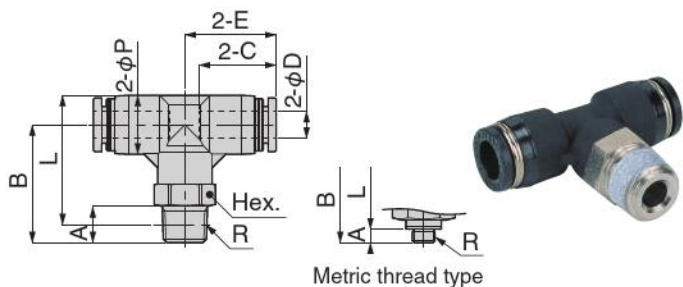

● New model **ATT**

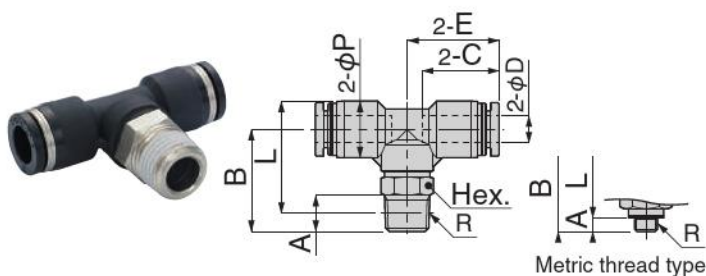

Unit: mm

Model	Tube outer diameter φ D	R	A	B	L	φ P	C	E	Width across flats Hex.	Orifice diameter (φ mm)	Mass g [oz]
TT4-M5-D	4	M5×0.8	3	20.2	22.2	10	14.9	16.9	10	1.8	11 [0.39]
ATT4-M5-D			2.8	16	18.2			17.7	8	2.4	8 [0.28]
TT4-M6-D	4	M6×1	4	21.2	22.2	10	14.9	16.9	10	2.4	11 [0.39]
ATT4-M6-D			3.8	20	21.2			18.7			
TT4-01-D	4	R1/8	8	23.2	24.2	10	14.9	16.9	10	2.8	14 [0.49]
ATT4-01-D				22	23			18.7			13 [0.46]
TT4-02-□	4	R1/4	11	26.2	25.2	10	14.9	16.9	14	2.8	23 [0.81]
ATT4-02-□				29	28			20.7			20 [0.71]
TT6-M5-D	6	M5×0.8	3	23	26.5	13	17	20.15	12	1.8	16 [0.56]
ATT6-M5-D			2.8	19.5	23			12.5	20.25	10	2.4
TT6-M6-D	6	M6×1	4	24	26.5	13	17	20.15	12	3	16 [0.56]
ATT6-M6-D			3.8	20.5	23			12.5	20.25		10
TT6-01-D	6	R1/8	8	26	28.5	13	17	20.15	12	4.3	18 [0.63]
ATT6-01-D				22.5	24.8			12.5	20.25		10
TT6-02-□	6	R1/4	11	29	29.5	13	17	20.15	14	4.3	26 [0.92]
ATT6-02-□				28	28.2			12.5			21.75
TT6-03-□	6	R3/8	12	30.8	31	13	17	20.15	17	4.3	39 [1.38]
ATT6-03-□				31.5	31.4			12.5			23.75
TT8-01-□	8	R1/8	8	26.3	29.8	15	18.1	22.4	14	5.8	23 [0.81]
ATT8-01-□				24	27.3			14.5	22.7	12	6
TT8-02-□	8	R1/4	11	29.3	30.8	15	18.1	22.4	14	5.8	29 [1.02]
ATT8-02-□				28	29.2			14.5			23.7
TT8-03-□	8	R3/8	12	31.1	32.3	15	18.1	22.4	17	5.8	42 [1.48]
ATT8-03-□				31	31.9			14.5			24.7
TT10-02-□	10	R1/4	11	36	38.7	17.5	20.2	25.2	17	8	42 [1.48]
ATT10-02-□				28.5	31.2			26	14		31 [1.09]
TT10-03-□	10	R3/8	12	37	39.4	17.5	20.2	25.2	17	8	50 [1.76]
ATT10-03-□				32	34.4			27			8.3
TT10-04-□	10	R1/2	15	40	40.6	17.5	20.2	25.2	21	8	72 [2.54]
ATT10-04-□				36	36.6			27.5			8.3
TT12-02-□	12	R1/4	11	38	42.5	21	22.9	28.4	21	8	61 [2.15]
ATT12-02-□				29.8	34.2			23.4	28.95		14
TT12-03-□	12	R3/8	12	39	43.2	21	22.9	28.4	21	10	62 [2.19]
ATT12-03-□				32.5	36.7			23.4	29.7		17
TT12-04-□	12	R1/2	15	42	44.3	21	22.9	28.4	21	10	78 [2.75]
ATT12-04-□				36.5	38.8			23.4			30.7

* -D ⇒ Non-lubricant specification only. -□ ⇒ Select either blank (standard) or D (non-lubricant specification)

* The L dimension for the tapered thread types is a reference dimension when mated and tightened.

* Prices are the same.

TB/ATB Branch tee

● Existing model TB

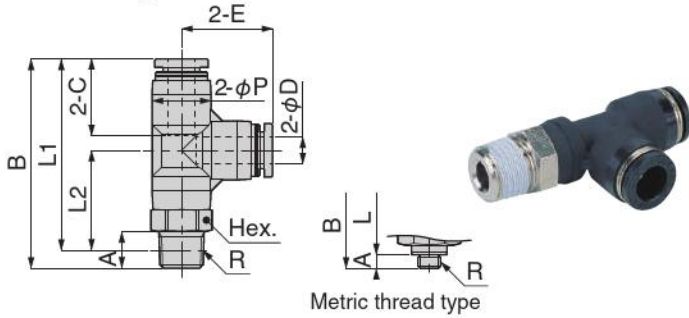

● New model ATB

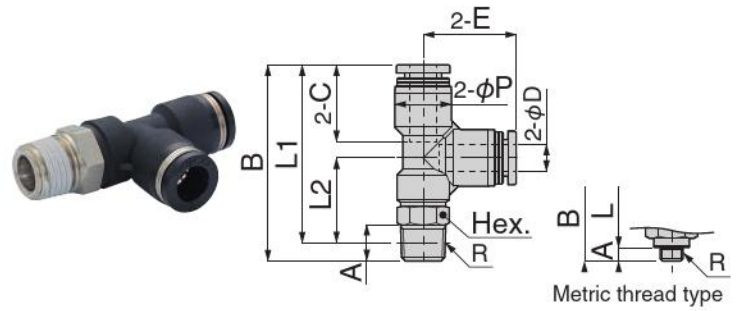

Unit: mm

Model	Tube outer diameter φ D	R	A	B	L1	L2	φ P	C	E	Width across flats Hex.	Orifice diameter (φ mm)	Mass g [oz]
TB4-M5-D	4	M5×0.8	3	37.1	34.1	17.2	10	14.9	16.9	10	1.8	11 [0.39]
ATB4-M5-D			2.8	33.7	30.9	13.7			17.2		8	2.4
TB4-M6-D	4	M6×1	4	38.1	34.1	17.2	10	14.9	16.9	10	2.4	11 [0.39]
ATB4-M6-D			3.8	38.2	34.4	17.2			17.2		10	2.4
TB4-01-D	4	R1/8	8	40.1	36.1	19.2	10	14.9	16.9	10	2.8	14 [0.49]
ATB4-01-D			40.2	36.2	19	17.2			17.2		2.8	13 [0.46]
TB4-02-□	4	R1/4	11	43.1	37.1	20.2	10	14.9	16.9	14	2.8	23 [0.81]
ATB4-02-□			46.2	40.2	23	19.2			19.2		2.8	20 [0.71]
TB6-M5-D	6	M5×0.8	3	43.2	40.2	20	13	17	20.1	12	1.8	16 [0.56]
ATB6-M5-D			2.8	40.3	37.5	17			12.5		20.5	10
TB6-M6-D	6	M6×1	4	44.2	40.2	20	13	17	20.1	12	3	17 [0.6]
ATB6-M6-D			3.8	41.3	37.5	17			12.5		20.5	10
TB6-01-D	6	R1/8	8	46.2	42.2	22	13	17	20.1	12	4.3	18 [0.63]
ATB6-01-D			43.3	39.3	18.8	12.5			20.5			10
TB6-02-□	6	R1/4	11	49.2	43.1	23	13	17	20.1	14	4.3	26 [0.92]
ATB6-02-□			48.8	42.7	22.2	12.5			20.5			14
TB6-03-□	6	R3/8	12	51	44.6	24.5	13	17	20.1	17	4.3	39 [1.38]
ATB6-03-□			52	45.7	25.2	12.5			21.5			17
TB8-01-□	8	R1/8	8	50.4	46.4	24.2	15	18.1	22.2	14	6	23 [0.81]
ATB8-01-□			46.9	42.9	20	14.5			22.9			12
TB8-02-□	8	R1/4	11	53.4	47.4	25.2	15	18.1	22.2	14	6	29 [1.02]
ATB8-02-□			51.7	45.7	22.8	14.5			22.9			14
TB8-03-□	8	R3/8	12	55.2	48.9	26.7	15	18.1	22.2	17	6	42 [1.48]
ATB8-03-□			55.4	49.1	26.2	14.5			22.9			17
TB10-02-□	10	R1/4	11	61.2	55.2	30	17.5	20.2	25.2	17	8	42 [1.48]
ATB10-02-□			54.7	48.7	22.5	17.5			26.2			14
TB10-03-□	10	R3/8	12	62.2	55.9	30.7	17.5	20.2	25.2	17	8	50 [1.76]
ATB10-03-□			58.2	51.9	25.7	17.5			26.2			17
TB10-04-□	10	R1/2	15	65.2	57	31.8	17.5	20.2	25.2	21	8	72 [2.54]
ATB10-04-□			62.2	54	27.8	17.5			27.3			21
TB12-02-□	12	R1/4	11	66.6	60.6	32.2	21	22.9	28.2	21	8	62 [2.19]
ATB12-02-□			60.3	54.2	23.7	21			23.4			30
TB12-03-□	12	R3/8	12	67.6	61.3	32.9	21	22.9	28.2	21	10	78 [2.75]
ATB12-03-□			63.5	57.2	26.7	21			23.4			30.5
TB12-04-□	12	R1/2	15	70.6	62.4	34	21	22.9	28.2	21	10	78 [2.75]
ATB12-04-□			67.5	59.3	28.8	21			23.4			30.7

* -D ⇒ Non-lubricant specification only. -□ ⇒ Select either blank (standard) or D (non-lubricant specification)

* The L dimension for the tapered thread types is a reference dimension when mated and tightened.

* Prices are the same.

TBY/ATBY Branch Y

● Existing model **TBY**

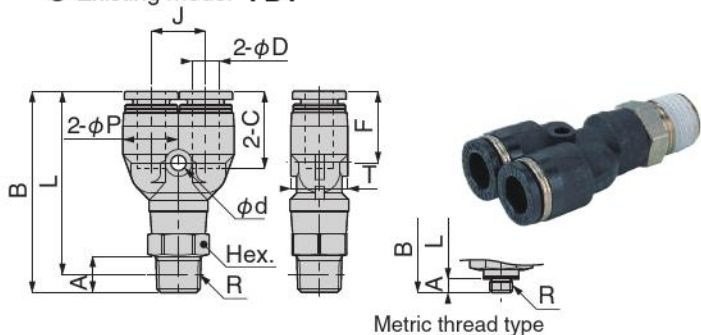

● New model **ATBY**

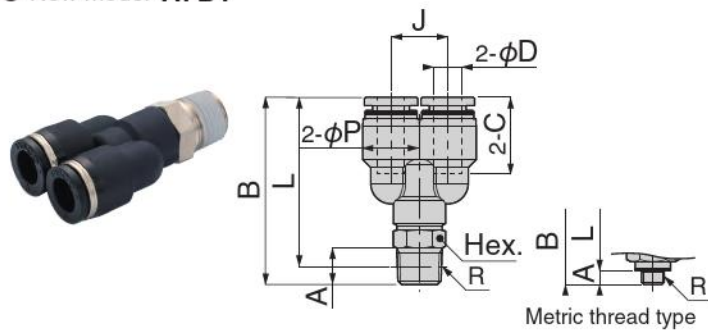

Metric thread type

Unit: mm

Model	Tube outer diameter φD	R	A	B	L	φP	C	J	φd	F	T	Width across flats Hex.	Orifice diameter (φ mm)	Mass g [oz]
TBY4-M5-□	4	M5×0.8	3	37.6	34.6	10	14.9	11	3.2	14.1	10.4	10	1.8	11 [0.39]
ATBY4-M5-□	4	M5×0.8	2.8	32.9	30.1	10	14.9	10.3	-	-	-	8	2.4	8 [0.28]
TBY4-01-□	4	R1/8	8	40.6	36.6	10	14.9	11	3.2	14.1	10.4	10	2.7	14 [0.49]
ATBY4-01-□	4	R1/8	8	38.4	34.4	10	14.9	10.3	-	-	-	10	2.8	13 [0.46]
TBY4-02-□	4	R1/4	11	43.6	37.6	10	14.9	11	3.2	14.1	10.4	14	2.7	23 [0.81]
ATBY4-02-□	4	R1/4	11	43.4	37.4	10	14.9	10.3	-	-	-	14	2.8	20 [0.71]
TBY6-M5-□	6	M5×0.8	3	41.4	38.4	12.5	17	12	3.4	15.8	13.5	12	1.8	16 [0.56]
ATBY6-M5-□	6	M5×0.8	2.8	38.3	35.5	12.5	17	12.5	-	-	-	10	2.4	13 [0.46]
TBY6-M6-□	6	M6×1	4	42.4	38.4	12.5	17	12	3.4	15.8	13.5	12	3	17 [0.6]
ATBY6-M6-□	6	M6×1	3.8	39.3	35.5	12.5	17	12.5	-	-	-	10	3	13 [0.46]
TBY6-01-□	6	R1/8	8	44.4	40.4	12.5	17	12	3.4	15.8	13.5	12	4.4	18 [0.63]
ATBY6-01-□	6	R1/8	8	41.3	37.3	12.5	17	12.5	-	-	-	10	4.3	15 [0.53]
TBY6-02-□	6	R1/4	11	47.4	41.3	12.5	17	12	3.4	15.8	13.5	14	4.4	26 [0.92]
ATBY6-02-□	6	R1/4	11	48.3	42.2	12.5	17	12.5	-	-	-	14	4.3	22 [0.78]
TBY6-03-□	6	R3/8	12	49.2	42.8	12.5	17	12	3.4	15.8	13.5	17	4.4	40 [1.41]
ATBY6-03-□	6	R3/8	12	51.3	44.9	12.5	17	12.5	-	-	-	17	4.3	33 [1.16]
TBY8-01-□	8	R1/8	8	48.7	44.7	14.5	18.1	14	3.4	17.2	15.1	14	5.9	24 [0.85]
ATBY8-01-□	8	R1/8	8	46.1	42.1	14.5	18.1	14.5	-	-	-	12	6	20 [0.71]
TBY8-02-□	8	R1/4	11	51.7	45.7	14.5	18.1	14	3.4	17.2	15.1	14	5.9	29 [1.02]
ATBY8-02-□	8	R1/4	11	49.3	43.3	14.5	18.1	14.5	-	-	-	14	6.7	25 [0.88]
TBY8-03-□	8	R3/8	12	53.5	47.2	14.5	18.1	14	3.4	17.2	15.1	17	5.9	43 [1.52]
ATBY8-03-□	8	R3/8	12	52.5	46.2	14.5	18.1	14.5	-	-	-	17	6.7	36 [1.27]
TBY10-02-□	10	R1/4	11	58.3	52.3	18	20.7	18	4.5	19.5	18	17	6.7	44 [1.55]
ATBY10-02-□	10	R1/4	11	53.6	47.6	17.5	20.2	17.5	-	-	-	14	8	32 [1.13]
TBY10-03-□	10	R3/8	12	59.3	53	18	20.7	18	4.5	19.5	18	17	6.7	52 [1.83]
ATBY10-03-□	10	R3/8	12	56.7	50.4	17.5	20.2	17.5	-	-	-	17	8.3	43 [1.52]
TBY10-04-□	10	R1/2	15	62.3	54.1	18	20.7	18	4.5	19.5	18	21	6.7	74 [2.61]
ATBY10-04-□	10	R1/2	15	60.2	52	17.5	20.2	17.5	-	-	-	21	8.3	66 [2.33]
TBY12-02-□	12	R1/4	11	63.5	57.5	21	23.4	20	4.2	22.2	21	21	8	64 [2.26]
ATBY12-02-□	12	R1/4	11	58.6	52.6	21	23.4	21	-	-	-	14	8	40 [1.41]
TBY12-03-□	12	R3/8	12	64.5	58.2	21	23.4	20	4.2	22.2	21	21	8	65 [2.29]
ATBY12-03-□	12	R3/8	12	60.6	54.3	21	23.4	21	-	-	-	17	10	51 [1.8]
TBY12-04-□	12	R1/2	15	67.5	59.3	21	23.4	20	4.2	22.2	21	21	8	81 [2.86]
ATBY12-04-□	12	R1/2	15	64.7	56.5	21	23.4	21	-	-	-	21	10.3	74 [2.61]

* -□ ⇒ Select either blank (standard) or D (non-lubricant specification)

* The L dimension for the tapered thread types is a reference dimension when mated and tightened.

* Prices are the same.

TBLY/ATBLY Branch elbow Y

● Existing model TBLY

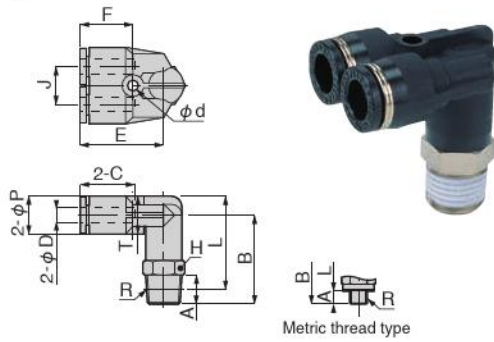

● New model ATBLY

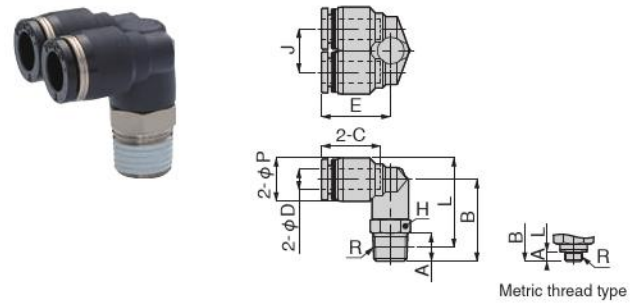

indicates portion of new models (new shapes) that have changed in dimension.

Unit: mm

Model	Tube outer diameter ϕD	R	A	B	L	ϕP	C	J	E	Width across flats Hex.	ϕd	F	T	Orifice diameter (ϕ mm)	Mass g [oz]
TBLY4-M5-□	4	M5×0.8	3	21.7	23.7	10	14.9	11	22.7	10	3.2	14.2	10	1.8	12 [0.423]
ATBLY4-M5-□			2.8	20	22.2			10.3	18.2						—
TBLY4-M6-□	4	M6×1	4	22.7	23.7	10	14.9	11	22.7	10	3.2	14.2	10	2.8	12 [0.423]
ATBLY4-M6-□			3.8	21	22.2			10.3	18.2						—
TBLY4-01-□	4	R1/8	8	24.7	25.7	10	14.9	11	22.7	10	3.2	14.2	10	2.8	15 [0.529]
ATBLY4-01-□			23	24	10.3			18.2	—						—
TBLY4-02-□	4	R1/4	11	27.7	26.7	10	14.9	11	22.7	14	3.2	14.2	10	2.8	24 [0.847]
ATBLY4-02-□			27	26	10.3			19.2	—						—
TBLY6-M5-□	6	M5×0.8	3	25	28.3	12.5	17	12	26.2	12	4.2	15.5	12.5	1.8	17 [0.600]
ATBLY6-M5-□			2.8	20.5	24			12.5	19.8						10
TBLY6-M6-□	6	M6×1	4	26	28.3	12.5	17	12	26.2	12	4.2	15.5	12.5	3	18 [0.635]
ATBLY6-M6-□			3.8	21.5	24			12.5	19.8						10
TBLY6-01-□	6	R1/8	8	28	30.3	12.5	17	12	26.2	12	4.2	15.5	12.5	4	19 [0.670]
ATBLY6-01-□			23.5	25.8	12.5			19.8	10						—
TBLY6-02-□	6	R1/4	11	31	31.2	12.5	17	12	26.2	14	4.2	15.5	12.5	4	27 [0.952]
ATBLY6-02-□			29	29.2	12.5			21.8	—						—
TBLY6-03-□	6	R3/8	12	32.8	32.7	12.5	17	12	26.2	17	4.2	15.5	12.5	4	40 [1.411]
ATBLY6-03-□			31.5	31.4	12.5			23.8	—						—
TBLY8-01-□	8	R1/8	8	31	34.3	14.5	18.1	14	29.4	14	4.2	16.9	14.5	4.1	25 [0.882]
ATBLY8-01-□			25	28.3	14.5			22.7	12						—
TBLY8-02-□	8	R1/4	11	34	35.2	14.5	18.1	14	29.4	14	4.2	16.9	14.5	4.1	31 [1.093]
ATBLY8-02-□			29	30.2	14.5			23.7	—						—
TBLY8-03-□	8	R3/8	12	35.8	36.7	14.5	18.1	14	29.4	17	4.2	16.9	14.5	4.1	44 [1.552]
ATBLY8-03-□			32	32.9	14.5			24.7	—						—
TBLY10-02-□	10	R1/4	11	37	39.7	17.5	20.2	18	33.5	17	4.2	18.5	17.5	7.5	46 [1.623]
ATBLY10-02-□			29.5	32.2	17.5			26	14						—
TBLY10-03-□	10	R3/8	12	38	40.4	17.5	20.2	18	33.5	17	4.2	18.5	17.5	7.5	54 [1.905]
ATBLY10-03-□			32.5	34.9	17.5			27	—						—
TBLY10-04-□	10	R1/2	15	41	41.6	17.5	20.2	18	33.5	21	4.2	18.5	17.5	7.5	76 [2.681]
ATBLY10-04-□			37	37.6	17.5			28	—						—
TBLY12-02-□	12	R1/4	11	41.2	45.7	21	23.4	20	35.2	21	4.2	20.4	21	8	67 [2.363]
ATBLY12-02-□			29.5	34	21			28.2	14						—
TBLY12-03-□	12	R3/8	12	42.2	46.4	21	23.4	20	35.2	21	4.2	20.4	21	9.8	68 [2.399]
ATBLY12-03-□			33.5	37.7	21			29.2	17						—
TBLY12-04-□	12	R1/2	15	45.2	47.5	21	23.4	20	35.2	21	4.2	20.4	21	9.8	83 [2.928]
ATBLY12-04-□			38	40.3	21			30.2	—						—

* - □ ⇒ Select either blank (standard) or D (non-lubricant specification)

* The L dimension for the tapered thread types is a reference dimension when mated and tightened.

* Prices are the same.

TBW/ATBW Branch double Y

● Existing model **TBW**

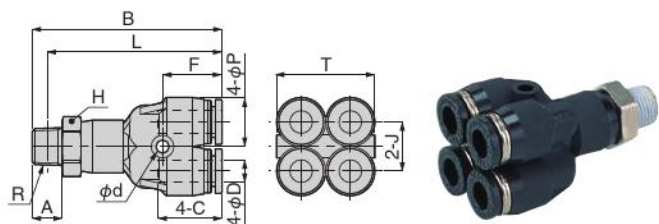

● New model **ATBW**

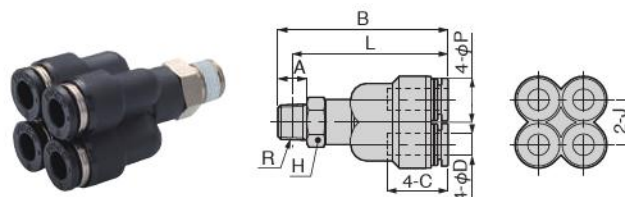

indicates portion of new models (new shapes) that have changed in dimension.

Unit: mm

Model	Tube outer diameter φD	R	A	B	L	φP	C	J	Width across flats Hex.	φd	F	T	Orifice diameter (φmm)	Mass g [oz]
TBW4-01-□	4	R1/8	8	45.7	41.7	10.5	14.9	10	12	3.2	14.2	20.5	2.1	22 [0.776]
ATBW4-01-□				38.9	34.9			10.3		—	—	—	2.6	16 [0.564]
TBW4-02-□	4	R1/4	11	48.7	42.7	10.5	14.9	10	14	3.2	14.2	20.5	2.1	30 [1.058]
ATBW4-02-□				42.4	36.4			10.3		—	—	—	2.6	21 [0.741]
TBW6-01-□	6	R1/8	8	50.3	46.3	13	17	13	14	3.5	15.8	26	4.3	29 [1.023]
ATBW6-01-□				47.2	43.2			12.5		12	—	—	—	5.2

* - □ ⇒ Select either blank (standard) or D (non-lubricant specification)

* The L dimension for the tapered thread types is a reference dimension when mated and tightened.

* Prices are the same.

TBE/ATBE Branch triple

● Existing model **TBE**

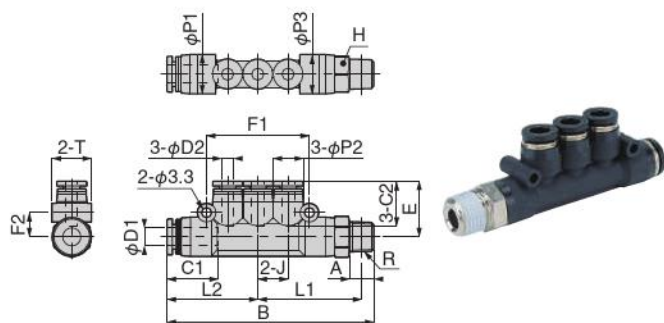

● New model **ATBE**

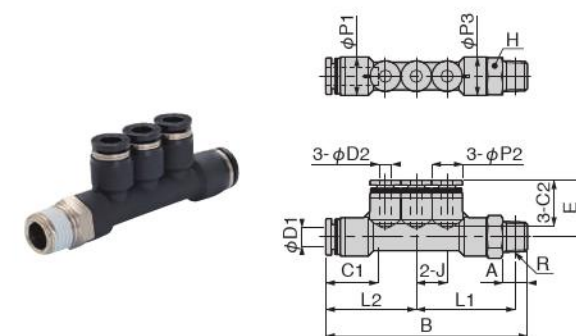

indicates portion of new models (new shapes) that have changed in dimension.

Unit: mm

Model	Tube outer diameter φD1	Tube outer diameter φD2	R	A	B	E	L1	L2	J	φP1	φP2	φP3	C1	C2	F1	F2	Width across flats Hex.	T	Orifice diameter (φmm)	Mass g [oz]
TBE6-4-01-□	6	4	R1/8	8	68.4	18.4	34.3	30.1	10	13	10	13	17	14.9	34	8	12	13	3	24 [0.847]
ATBE6-4-01-□					65.4		32.1	29.3		12.5		12.5			—	—		—		—
TBE8-4-02-□	8	4	R1/4	11	73.7	19.2	36.5	31.2	10	15	10	15	18.1	14.9	34	9.2	14	15	3	34 [1.199]
ATBE8-4-02-□					69.2		32	14.5		14.5		—			—	—		—		28 [0.988]
TBE8-6-02-□	8	6	R1/4	11	80.7	21.3	40	34.7	12	15	13	15	18.1	17	40.2	9	14	15	4.6	37 [1.305]
ATBE8-6-02-□					76.9		36.5	34.4		12.5		14.5			12.5	14.5		—		—
TBE10-8-03-□	10	8	R3/8	12	93	23.7	46.7	40	14	15	17.5	17.5	20.7	18.1	46.2	10.5	17	17.5	7	60 [2.116]
ATBE10-8-03-□					87.8		41.5	14.5		14.5		18			20.2	—		—		—

* - □ ⇒ Select either blank (standard) or D (non-lubricant specification)

* The L1 dimension for the tapered thread types is a reference dimension when mated and tightened.

* Prices are the same.

TBEW/ATBEW Branch triple double

Existing model TBEW

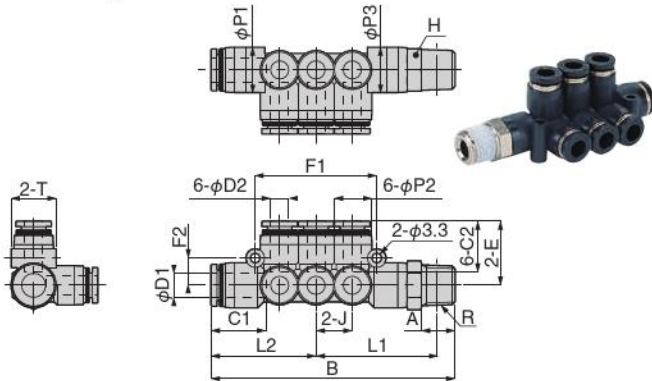

New model ATBEW

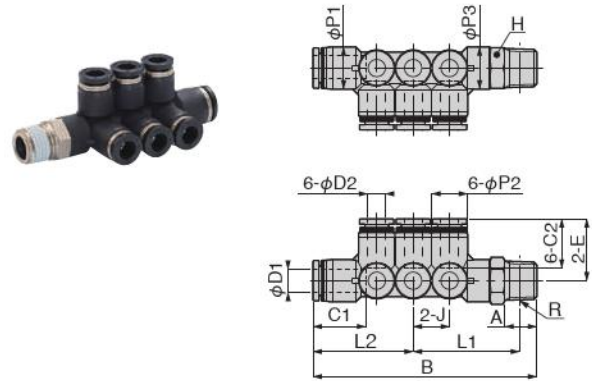

indicates portion of new models (new shapes) that have changed in dimension.

Unit: mm

Model	Tube outer diameter $\phi D1$	Tube outer diameter $\phi D2$	R	A	B	E	L1	L2	J	$\phi P1$	$\phi P2$	$\phi P3$	C1	C2	F1	F2	Width across flats Hex.	T	Orifice diameter (ϕ mm)	Mass g [oz]
TBEW8-4-02-□	8	4	R1/4	11	80.7	20.7	40	34.7	12	15	13	15	18.1	14.9	40.2	9	14	15	3	45 [1.587]
ATBEW8-4-02-□					69.2	19.2	32	31.2	10	14.5	10	14.5			—	—				—
TBEW8-4-03-□	8	4	R3/8	12	82.5	20.7	41.5	34.7	12	15	13	15	18.1	14.9	40.2	9	17	15	3	58 [2.046]
ATBEW8-4-03-□					72.2	19.2	34.7	31.2	10	14.5	10	18			—	—				—
TBEW8-6-02-□	8	6	R1/4	11	80.7	21.3	40	34.7	12	15	13	15	18.1	17	40.2	9	14	15	4.6	47 [1.658]
ATBEW8-6-02-□					76.9		36.5	34.4	12.5	14.5	12.5	14.5			—	—				—
TBEW8-6-03-□	8	6	R3/8	12	82.5	21.3	41.5	34.7	12	15	13	15	18.1	17	40.2	9	17	15	4.6	60 [2.116]
ATBEW8-6-03-□					80.7		39.9	34.4	12.5	14.5	12.5	18			—	—				—
TBEW10-6-03-□	10	6	R3/8	12	93	23.8	46.7	40	14	17.5	15	17.5	20.2	17	46.2	10.5	17	17.5	4.6	70 [2.469]
ATBEW10-6-03-□					81.5	22.3	38.2	37	12.5		12.5	18			—	—				—
TBEW10-6-04-□	10	6	R1/2	15	96	23.8	47.8	40	14	17.5	15	17.5	20.2	17	46.2	10.5	21	17.5	4.6	93 [3.280]
ATBEW10-6-04-□					85.5	22.3	40.3	37	12.5		12.5	20			—	—				—
TBEW10-8-03-□	10	8	R3/8	12	93	23.7	46.7	40	14	17.5	15	17.5	20.2	18.1	46.2	10.5	17	17.5	7	74 [2.610]
ATBEW10-8-03-□					87.8		41.5		14.5		14.5	18			—	—				—
TBEW10-8-04-□	10	8	R1/2	15	96	23.7	47.8	40	14	17.5	15	17.5	20.2	18.1	46.2	10.5	21	17.5	7	96 [3.386]
ATBEW10-8-04-□					91.8		43.6		14.5		14.5	20			—	—				—

* - □ ⇒ Select either blank (standard) or D (non-lubricant specification)

* The L1 dimension for the tapered thread types is a reference dimension when mated and tightened.

* Prices are the same.

TBZ/ATBZ Branch tetra

Existing model TBZ

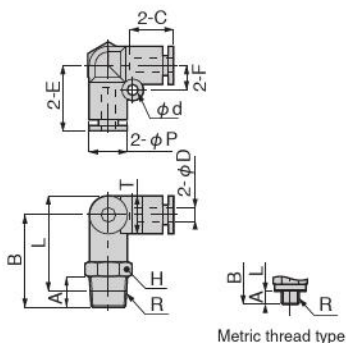

New model ATBZ

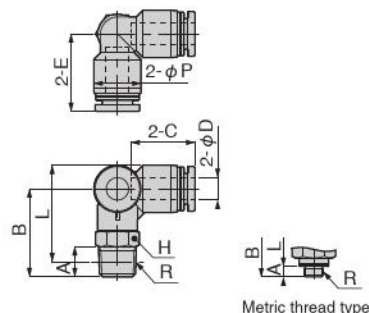

indicates portion of new models (new shapes) that have changed in dimension.

Unit: mm

Model	Tube outer diameter ϕD	R	A	B	L	ϕP	C	E	Width across flats Hex.	ϕd	F	T	Orifice diameter (ϕ mm)	Mass g [oz]
TBZ4-M5-□	4	M5×0.8	3	21.7	23.7	10	14.9	16.9	10	3.2	6.5	10	1.8	11 [0.388]
ATBZ4-M5-□			2.8	20.3	22.5			18.2						2.4
TBZ4-M6-□	4	M6×1	4	22.7	23.7	10	14.9	16.9	10	3.2	6.5	10	3	11 [0.388]
ATBZ4-M6-□			3.8	21.3	22.5			18.2						3
TBZ4-01-□	4	R1/8	8	24.7	25.7	10	14.9	16.9	10	3.2	6.5	10	3	14 [0.494]
ATBZ4-01-□				23.3	24.3			18.2						13 [0.459]
TBZ4-02-□	4	R1/4	11	27.7	26.7	10	14.9	16.9	14	3.2	6.5	10	3	23 [0.811]
ATBZ4-02-□				29	28			20.7						20 [0.705]
TBZ6-M5-□	6	M5×0.8	3	25.3	28.6	12.5	17	20.1	12	4.2	8	12.5	1.8	17 [0.600]
ATBZ6-M5-□			2.8	20.3	23.7			20.5						10
TBZ6-M6-□	6	M6×1	4	26.3	28.6	12.5	17	20.1	12	4.2	8	12.5	3	17 [0.600]
ATBZ6-M6-□			3.8	21.3	23.7			20.5						10
TBZ6-01-□	6	R1/8	8	28.3	30.6	12.5	17	20.1	12	4.2	8	12.5	4.6	18 [0.635]
ATBZ6-01-□				23.3	25.5			20.5						10
TBZ6-02-□	6	R1/4	11	31.3	31.5	12.5	17	20.1	14	4.2	8	12.5	4.6	26 [0.917]
ATBZ6-02-□				28	28.2			21.8						22 [0.776]
TBZ6-03-□	6	R3/8	12	33.1	33	12.5	17	20.1	17	4.2	8	12.5	4.6	39 [1.376]
ATBZ6-03-□				31.5	31.4			23.8						33 [1.164]
TBZ8-01-□	8	R1/8	8	30.4	33.7	14.5	18.1	22.1	14	4.2	10	14.5	6	24 [0.847]
ATBZ8-01-□				25	28.3			22.7						12
TBZ8-02-□	8	R1/4	11	33.4	34.6	14.5	18.1	22.1	14	4.2	10	14.5	6	30 [1.058]
ATBZ8-02-□				29	30.2			23.7						14
TBZ8-03-□	8	R3/8	12	35.2	36.1	14.5	18.1	22.1	17	4.2	10	14.5	6	42 [1.482]
ATBZ8-03-□				32	32.9			24.7						17
TBZ10-02-□	10	R1/4	11	38.2	40.9	17.5	20.2	26.2	17	4.2	12	17.5	8	44 [1.552]
ATBZ10-02-□				29.4	32.1			26						14
TBZ10-03-□	10	R3/8	12	39.2	41.6	17.5	20.2	26.2	17	4.2	12	17.5	8	52 [1.834]
ATBZ10-03-□				33	35.4			27						17
TBZ10-04-□	10	R1/2	15	42.2	42.8	17.5	20.2	26.2	21	4.2	12	17.5	8	74 [2.610]
ATBZ10-04-□				37	37.6			27.5						21
TBZ12-02-□	12	R1/4	11	41.2	45.7	21	23.4	29.4	21	4.2	14	21	8	64 [2.258]
ATBZ12-02-□				30.8	35.2			30.2						14
TBZ12-03-□	12	R3/8	12	42.2	46.4	21	23.4	29.4	21	4.2	14	21	10	65 [2.293]
ATBZ12-03-□				33.5	37.7			30.2						17
TBZ12-04-□	12	R1/2	15	45.2	47.5	21	23.4	29.4	21	4.2	14	21	10	81 [2.857]
ATBZ12-04-□				38	40.3			31.2						21

* - □ ⇒ Select either blank (standard) or D (non-lubricant specification)

* The L dimension for the tapered thread types is a reference dimension when mated and tightened.

* Prices are the same.

Supply joint

SKR/ASKR Reducer for bulkhead

● Existing model **SKR**

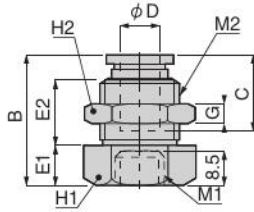

● New model **ASKR**

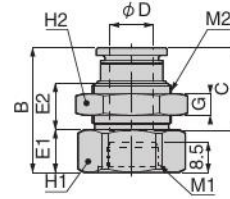

■ indicates portion of new models (new shapes) that have changed in dimension.

Unit: mm

Model	Tube outer diameter ϕD	M1	M2	B	E1	E2	C	G	H1	H2	Effective cross section area (mm ²)	Mass g [oz]
SKR8-4	4	M8×1	M12×1	26	8	13.4	14.9	4	14	14	5.6	19 [0.670]
ASKR8-4						11.8						18 [0.635]
SKR8-6	6	M8×1	M14×1	28.1	8	14.9	17	4	17	17	11.5	29 [1.023]
ASKR8-6						13.9						
SKR12-6	6	M12×1	M14×1	28.1	12	10.9	17	4	17	17	13.2	28 [0.988]
ASKR12-6						9.9						
SKR12-8	8	M12×1	M16×1	28.9	10	13.4	18.2	4	19	19	27.4	34 [1.199]
ASKR12-8						11.7						33 [1.164]
SKR12-10	10	M12×1	M20×1	32.3	10	16.4	20.7	5	22	24	34.8	60 [2.116]
ASKR12-10						13.7						57 [2.011]
SKR14-8	8	M14×1	M16×1	28.9	12	11.4	18.2	4	19	19	27.7	33 [1.164]
ASKR14-8						9.7						32 [1.129]
SKR14-10	10	M14×1	M20×1	32.3	10	16.4	20.7	5	24	24	41.7	64 [2.258]
ASKR14-10						13.7						60 [2.116]
SKR14-12	12	M14×1	M22×1	34.9	12	17.4	23.3	6	24	27	54.7	78 [2.751]
ASKR14-12						13						74 [2.610]
SKR18-12	12	M18×1	M22×1	34.9	12	17.4	23.3	6	27	27	66.7	83 [2.928]
ASKR18-12						13						79 [2.787]

* Prices are the same.

Supply joint (assembly side)



List of models and their specifications

* See the following table for combinations of models of fittings, tube size, and thread size.

Regarding NCU specifications, the "←" indicates that the standard model can be used as NCU specifications, so order the standard model.

- The dimension diagram for the following NCU specifications and the CS specifications are the same as the standard model or the non-lubricant specifications. Refer to the dimension diagrams on pages ① to ⑩.

● Table of models

Name	Tube outer diameter	Thread size	Standard model or non-lubricant specifications	NCU Specification	CS Specification	
Straight ATS	4	M5×0.8	ATS4-M5-D	—	CS-ATS4-M5	
			ATS4-M50-□	←	CS-ATS4-M50	
		M6×1	ATS4-M6-D	—	CS-ATS4-M6	
			R1/8	ATS4-01-D	NCU-ATS4-01	CS-ATS4-01
			R1/4	ATS4-02-□	NCU-ATS4-02	CS-ATS4-02
	6	M5×0.8	ATS6-M5-D	—	CS-ATS6-M5	
			ATS6-M6-D	—	CS-ATS6-M6	
		R1/8	ATS6-01-D	NCU-ATS6-01	CS-ATS6-01	
			R1/4	ATS6-02-□	NCU-ATS6-02	CS-ATS6-02
			R3/8	ATS6-03-□	NCU-ATS6-03	CS-ATS6-03
	8	R1/8	ATS8-01-□	NCU-ATS8-01	CS-ATS8-01	
		R1/4	ATS8-02-□	NCU-ATS8-02	CS-ATS8-02	
		R3/8	ATS8-03-□	NCU-ATS8-03	CS-ATS8-03	
	10	R1/8	ATS10-01-□	NCU-ATS10-01	CS-ATS10-01	
		R1/4	ATS10-02-□	NCU-ATS10-02	CS-ATS10-02	
		R3/8	ATS10-03-□	NCU-ATS10-03	CS-ATS10-03	
		R1/2	ATS10-04-□	NCU-ATS10-04	CS-ATS10-04	
	12	R1/4	ATS12-02-□	NCU-ATS12-02	CS-ATS12-02	
		R3/8	ATS12-03-□	NCU-ATS12-03	CS-ATS12-03	
		R1/2	ATS12-04-□	NCU-ATS12-04	CS-ATS12-04	
16	R3/8	ATS16-03-□	NCU-ATS16-03	CS-ATS16-03		
	R1/2	ATS16-04-□	NCU-ATS16-04	CS-ATS16-04		
Straight with hexagon socket ATSH	4	M5×0.8	ATSH4-M5-D	—	CS-ATSH4-M5	
			ATSH4-M6-D	—	CS-ATSH4-M6	
		R1/8	ATSH4-01-D	NCU-ATSH4-01	CS-ATSH4-01	
	6	M5×0.8	ATSH6-M5-D	—	CS-ATSH6-M5	
			ATSH6-M6-D	—	CS-ATSH6-M6	
		R1/8	ATSH6-01-D	NCU-ATSH6-01	CS-ATSH6-01	
	8	R1/4	ATSH6-02-□	NCU-ATSH6-02	CS-ATSH6-02	
		R1/8	ATSH8-01-□	NCU-ATSH8-01	CS-ATSH8-01	
		R1/4	ATSH8-02-□	NCU-ATSH8-02	CS-ATSH8-02	
		R3/8	ATSH8-03-□	NCU-ATSH8-03	CS-ATSH8-03	
	10	R1/4	ATSH10-02-□	NCU-ATSH10-02	CS-ATSH10-02	
		R3/8	ATSH10-03-□	NCU-ATSH10-03	CS-ATSH10-03	
		R1/2	ATSH10-04-□	NCU-ATSH10-04	CS-ATSH10-04	
	12	R3/8	ATSH12-03-□	NCU-ATSH12-03	CS-ATSH12-03	
		R1/2	ATSH12-04-□	NCU-ATSH12-04	CS-ATSH12-04	
	Female straight ATSM	4	Rc1/8	ATSM4-01-□	←	CS-ATSM4-01
Rc1/4			ATSM4-02-□	←	CS-ATSM4-02	
6		Rc1/8	ATSM6-01-□	←	CS-ATSM6-01	
		Rc1/4	ATSM6-02-□	←	CS-ATSM6-02	
8		Rc1/8	ATSM8-01-□	←	CS-ATSM8-01	
		Rc1/4	ATSM8-02-□	←	CS-ATSM8-02	
		Rc3/8	ATSM8-03-□	←	CS-ATSM8-03	
10		Rc1/4	ATSM10-02-□	←	CS-ATSM10-02	
		Rc3/8	ATSM10-03-□	←	CS-ATSM10-03	
12		Rc1/4	ATSM12-02-□	←	CS-ATSM12-02	
		Rc3/8	ATSM12-03-□	←	CS-ATSM12-03	

* -D ⇒ Non-lubricant specification only. -□ ⇒ Select either blank (standard) or D (non-lubricant specification)

Name	Tube outer diameter	Thread size	Standard model or non-lubricant specifications	NCU Specification	CS Specification	
Union for bulkhead AUK	4	—	AUK4-D	—	CS-AUK4	
	6	—	AUK6-D	—	CS-AUK6	
	8	—	AUK8-□	←	CS-AUK8	
	10	—	AUK10-□	←	CS-AUK10	
	12	—	AUK12-□	←	CS-AUK12	
Female union for bulkhead AUKM	4	Rc1/8	AUKM4-01-□	←	CS-AUKM4-01	
		Rc1/8	AUKM6-01-□	←	CS-AUKM6-01	
	6	Rc1/4	AUKM6-02-□	←	CS-AUKM6-02	
		Rc1/8	AUKM8-01-□	←	CS-AUKM8-01	
	8	Rc1/4	AUKM8-02-□	←	CS-AUKM8-02	
		Rc3/8	AUKM8-03-□	←	CS-AUKM8-03	
	10	Rc1/4	AUKM10-02-□	←	CS-AUKM10-02	
		Rc3/8	AUKM10-03-□	←	CS-AUKM10-03	
	12	Rc3/8	AUKM12-03-□	←	CS-AUKM12-03	
		Rc1/2	AUKM12-04-□	←	CS-AUKM12-04	
	Elbow ATL	4	M5×0.8	ATL4-M5-D	—	CS-ATL4-M5
				ATL4-M6-D	—	CS-ATL4-M6
R1/8			ATL4-01-D	NCU-ATL4-01	CS-ATL4-01	
6		M5×0.8	ATL6-M5-D	—	CS-ATL6-M5	
			ATL6-M6-D	—	CS-ATL6-M6	
		R1/8	ATL6-01-D	NCU-ATL6-01	CS-ATL6-01	
		R1/4	ATL6-02-□	NCU-ATL6-02	CS-ATL6-02	
8		R3/8	ATL6-03-□	NCU-ATL6-03	CS-ATL6-03	
		R1/8	ATL8-01-□	NCU-ATL8-01	CS-ATL8-01	
		R1/4	ATL8-02-□	NCU-ATL8-02	CS-ATL8-02	
10		R3/8	ATL8-03-□	NCU-ATL8-03	CS-ATL8-03	
		R1/8	ATL10-01-□	NCU-ATL10-01	CS-ATL10-01	
		R1/4	ATL10-02-□	NCU-ATL10-02	CS-ATL10-02	
		R3/8	ATL10-03-□	NCU-ATL10-03	CS-ATL10-03	
12		R1/2	ATL10-04-□	NCU-ATL10-04	CS-ATL10-04	
		R1/4	ATL12-02-□	NCU-ATL12-02	CS-ATL12-02	
	R3/8	ATL12-03-□	NCU-ATL12-03	CS-ATL12-03		
Long elbow ATLL	4	M5×0.8	ATLL4-M5-D	—	CS-ATLL4-M5	
			ATLL4-01-D	NCU-ATLL4-01	CS-ATLL4-01	
	6	R1/8	ATLL6-01-D	NCU-ATLL6-01	CS-ATLL6-01	
		R1/4	ATLL6-02-□	NCU-ATLL6-02	CS-ATLL6-02	
		R3/8	ATLL6-03-□	NCU-ATLL6-03	CS-ATLL6-03	
	8	R1/8	ATLL8-01-□	NCU-ATLL8-01	CS-ATLL8-01	
		R1/4	ATLL8-02-□	NCU-ATLL8-02	CS-ATLL8-02	
		R3/8	ATLL8-03-□	NCU-ATLL8-03	CS-ATLL8-03	
	10	R1/4	ATLL10-02-□	NCU-ATLL10-02	CS-ATLL10-02	
		R3/8	ATLL10-03-□	NCU-ATLL10-03	CS-ATLL10-03	
		R1/2	ATLL10-04-□	NCU-ATLL10-04	CS-ATLL10-04	
	12	R1/4	ATLL12-02-□	NCU-ATLL12-02	CS-ATLL12-02	
R3/8		ATLL12-03-□	NCU-ATLL12-03	CS-ATLL12-03		
R1/2		ATLL12-04-□	NCU-ATLL12-04	CS-ATLL12-04		

* -D ⇒ Non-lubricant specification only. -□ ⇒ Select either blank (standard) or D (non-lubricant specification)

List of models and their specifications

* See the following table for combinations of models of fittings, tube size, and thread size.

Regarding NCU specifications, the "←" indicates that the standard model can be used as NCU specifications, so order the standard model.

- The dimension diagram for the following NCU specifications and the CS specifications are the same as the standard model or the non-lubricant specifications. Refer to the dimension diagrams on pages ① to ⑩.

● Table of models

Name	Tube outer diameter	Thread size	Standard model or non-lubricant specifications	NCU Specification	CS Specification
Tee ATT	4	M5×0.8	ATT4-M5-D	—	CS-ATT4-M5
		M6×1	ATT4-M6-D	—	CS-ATT4-M6
		R1/8	ATT4-01-D	NCU-ATT4-01	CS-ATT4-01
		R1/4	ATT4-02-□	NCU-ATT4-02	CS-ATT4-02
	6	M5×0.8	ATT6-M5-D	—	CS-ATT6-M5
		M6×1	ATT6-M6-D	—	CS-ATT6-M6
		R1/8	ATT6-01-D	NCU-ATT6-01	CS-ATT6-01
		R1/4	ATT6-02-□	NCU-ATT6-02	CS-ATT6-02
		R3/8	ATT6-03-□	NCU-ATT6-03	CS-ATT6-03
		R1/8	ATT8-01-□	NCU-ATT8-01	CS-ATT8-01
	8	R1/4	ATT8-02-□	NCU-ATT8-02	CS-ATT8-02
		R3/8	ATT8-03-□	NCU-ATT8-03	CS-ATT8-03
		R1/4	ATT10-02-□	NCU-ATT10-02	CS-ATT10-02
	10	R3/8	ATT10-03-□	NCU-ATT10-03	CS-ATT10-03
		R1/2	ATT10-04-□	NCU-ATT10-04	CS-ATT10-04
		R1/4	ATT12-02-□	NCU-ATT12-02	CS-ATT12-02
	12	R3/8	ATT12-03-□	NCU-ATT12-03	CS-ATT12-03
		R1/2	ATT12-04-□	NCU-ATT12-04	CS-ATT12-04
		M5×0.8	ATB4-M5-D	—	CS-ATB4-M5
	4	M6×1	ATB4-M6-D	—	CS-ATB4-M6
R1/8		ATB4-01-D	NCU-ATB4-01	CS-ATB4-01	
R1/4		ATB4-02-□	NCU-ATB4-02	CS-ATB4-02	
M5×0.8		ATB6-M5-D	—	CS-ATB6-M5	
6	M6×1	ATB6-M6-D	—	CS-ATB6-M6	
	R1/8	ATB6-01-D	NCU-ATB6-01	CS-ATB6-01	
	R1/4	ATB6-02-□	NCU-ATB6-02	CS-ATB6-02	
	R3/8	ATB6-03-□	NCU-ATB6-03	CS-ATB6-03	
	R1/8	ATB8-01-□	NCU-ATB8-01	CS-ATB8-01	
8	R1/4	ATB8-02-□	NCU-ATB8-02	CS-ATB8-02	
	R3/8	ATB8-03-□	NCU-ATB8-03	CS-ATB8-03	
	R1/4	ATB10-02-□	NCU-ATB10-02	CS-ATB10-02	
10	R3/8	ATB10-03-□	NCU-ATB10-03	CS-ATB10-03	
	R1/2	ATB10-04-□	NCU-ATB10-04	CS-ATB10-04	
	R1/4	ATB12-02-□	NCU-ATB12-02	CS-ATB12-02	
12	R3/8	ATB12-03-□	NCU-ATB12-03	CS-ATB12-03	
	R1/2	ATB12-04-□	NCU-ATB12-04	CS-ATB12-04	
	M5×0.8	ATBY4-M5-□	←	CS-ATBY4-M5	
4	R1/8	ATBY4-01-□	NCU-ATBY4-01	CS-ATBY4-01	
	R1/4	ATBY4-02-□	NCU-ATBY4-02	CS-ATBY4-02	
	M5×0.8	ATBY6-M5-□	←	CS-ATBY6-M5	
6	M6×1	ATBY6-M6-□	←	CS-ATBY6-M6	
	R1/8	ATBY6-01-□	NCU-ATBY6-01	CS-ATBY6-01	
	R1/4	ATBY6-02-□	NCU-ATBY6-02	CS-ATBY6-02	
	R3/8	ATBY6-03-□	NCU-ATBY6-03	CS-ATBY6-03	
	R1/8	ATBY8-01-□	NCU-ATBY8-01	CS-ATBY8-01	
8	R1/4	ATBY8-02-□	NCU-ATBY8-02	CS-ATBY8-02	
	R3/8	ATBY8-03-□	NCU-ATBY8-03	CS-ATBY8-03	
	R1/4	ATBY10-02-□	NCU-ATBY10-02	CS-ATBY10-02	
10	R3/8	ATBY10-03-□	NCU-ATBY10-03	CS-ATBY10-03	
	R1/2	ATBY10-04-□	NCU-ATBY10-04	CS-ATBY10-04	
	R1/4	ATBY12-02-□	NCU-ATBY12-02	CS-ATBY12-02	
12	R3/8	ATBY12-03-□	NCU-ATBY12-03	CS-ATBY12-03	
	R1/2	ATBY12-04-□	NCU-ATBY12-04	CS-ATBY12-04	

* -D ⇒ Non-lubricant specification only. -□ ⇒ Select either blank (standard) or D (non-lubricant specification)

● Tightening torque (reference value), sealant color, and gasket material for targeted models

Thread type	Thread size	Tightening torque N·m [in·lbf]	Sealant color	Gasket material
Metric thread	M5 × 0.8	1 to 1.5 [8.85 to 13.28]	—	SUS304 NBR
	M6 × 1	2 to 2.7 [17.70 to 23.90]		
Tapered threads for pipes*	R1/8	4.5 to 6.5 [39.83 to 57.53]	White	—
	R1/4	7 to 9 [61.96 to 79.66]		
	R3/8	12.5 to 14.5 [110.64 to 128.34]		
	R1/2	20 to 22 [177.02 to 194.72]		

* The tightening torque is the same for all products with tapered threads for quick fitting pipes.

List of models and their specifications

* See the following table for combinations of models of fittings, tube size, and thread size.

Regarding NCU specifications, the "←" indicates that the standard model can be used as NCU specifications, so order the standard model.

● The dimension diagram for the following NCU specifications and the CS specifications are the same as the standard model or the non-lubricant specifications. Refer to the dimension diagrams on pages ① to ⑤.

● Standard type models of quick fittings

Name	Tube outer diameter	Thread size	Standard model or non-lubricant specifications	NCU Specification	CS Specification	
Branch elbow Y ATBLY	4	M5×0.8	ATBLY4-M5-□	←	CS-ATBLY4-M5	
		M6×1	ATBLY4-M6-□	←	CS-ATBLY4-M6	
		R1/8	ATBLY4-01-□	NCU-ATBLY4-01	CS-ATBLY4-01	
		R1/4	ATBLY4-02-□	NCU-ATBLY4-02	CS-ATBLY4-02	
	6	M5×0.8	ATBLY6-M5-□	←	CS-ATBLY6-M5	
		M6×1	ATBLY6-M6-□	←	CS-ATBLY6-M6	
		R1/8	ATBLY6-01-□	NCU-ATBLY6-01	CS-ATBLY6-01	
		R1/4	ATBLY6-02-□	NCU-ATBLY6-02	CS-ATBLY6-02	
		R3/8	ATBLY6-03-□	NCU-ATBLY6-03	CS-ATBLY6-03	
		R1/8	ATBLY8-01-□	NCU-ATBLY8-01	CS-ATBLY8-01	
	8	R1/4	ATBLY8-02-□	NCU-ATBLY8-02	CS-ATBLY8-02	
		R3/8	ATBLY8-03-□	NCU-ATBLY8-03	CS-ATBLY8-03	
		R1/4	ATBLY10-02-□	NCU-ATBLY10-02	CS-ATBLY10-02	
	10	R3/8	ATBLY10-03-□	NCU-ATBLY10-03	CS-ATBLY10-03	
		R1/2	ATBLY10-04-□	NCU-ATBLY10-04	CS-ATBLY10-04	
		R1/4	ATBLY12-02-□	NCU-ATBLY12-02	CS-ATBLY12-02	
	12	R3/8	ATBLY12-03-□	NCU-ATBLY12-03	CS-ATBLY12-03	
		R1/2	ATBLY12-04-□	NCU-ATBLY12-04	CS-ATBLY12-04	
		Branch triple ATBE	6-4	R1/8	ATBE6-4-01-□	NCU-ATBE6-4-01
	8-4		R1/4	ATBE8-4-02-□	NCU-ATBE8-4-02	CS-ATBE8-4-02
	8-6		R1/4	ATBE8-6-02-□	NCU-ATBE8-6-02	CS-ATBE8-6-02
	10-8		R3/8	ATBE10-8-03-□	NCU-ATBE10-8-03	CS-ATBE10-8-03
	Branch triple double ATBEW	8-4	R1/4	ATBEW8-4-02-□	NCU-ATBEW8-4-02	CS-ATBEW8-4-02
			R3/8	ATBEW8-4-03-□	NCU-ATBEW8-4-03	CS-ATBEW8-4-03
8-6		R1/4	ATBEW8-6-02-□	NCU-ATBEW8-6-02	CS-ATBEW8-6-02	
		R3/8	ATBEW8-6-03-□	NCU-ATBEW8-6-03	CS-ATBEW8-6-03	
10-6		R3/8	ATBEW10-6-03-□	NCU-ATBEW10-6-03	CS-ATBEW10-6-03	
		R1/2	ATBEW10-6-04-□	NCU-ATBEW10-6-04	CS-ATBEW10-6-04	
10-8		R3/8	ATBEW10-8-03-□	NCU-ATBEW10-8-03	CS-ATBEW10-8-03	
		R1/2	ATBEW10-8-04-□	NCU-ATBEW10-8-04	CS-ATBEW10-8-04	
Branch double Y ATBW	4	R1/8	ATBW4-01-□	NCU-ATBW4-01	CS-ATBW4-01	
		R1/4	ATBW4-02-□	NCU-ATBW4-02	CS-ATBW4-02	
	6	R1/8	ATBW6-01-□	NCU-ATBW6-01	CS-ATBW6-01	
Branch tetra ATBZ	4	M5×0.8	ATBZ4-M5-□	←	CS-ATBZ4-M5	
		M6×1	ATBZ4-M6-□	←	CS-ATBZ4-M6	
		R1/8	ATBZ4-01-□	NCU-ATBZ4-01	CS-ATBZ4-01	
		R1/4	ATBZ4-02-□	NCU-ATBZ4-02	CS-ATBZ4-02	
	6	M5×0.8	ATBZ6-M5-□	←	CS-ATBZ6-M5	
		M6×1	ATBZ6-M6-□	←	CS-ATBZ6-M6	
		R1/8	ATBZ6-01-□	NCU-ATBZ6-01	CS-ATBZ6-01	
		R1/4	ATBZ6-02-□	NCU-ATBZ6-02	CS-ATBZ6-02	
		R3/8	ATBZ6-03-□	NCU-ATBZ6-03	CS-ATBZ6-03	
		R1/8	ATBZ8-01-□	NCU-ATBZ8-01	CS-ATBZ8-01	
	8	R1/4	ATBZ8-02-□	NCU-ATBZ8-02	CS-ATBZ8-02	
		R3/8	ATBZ8-03-□	NCU-ATBZ8-03	CS-ATBZ8-03	
		R1/4	ATBZ10-02-□	NCU-ATBZ10-02	CS-ATBZ10-02	
	10	R3/8	ATBZ10-03-□	NCU-ATBZ10-03	CS-ATBZ10-03	
		R1/2	ATBZ10-04-□	NCU-ATBZ10-04	CS-ATBZ10-04	
		R1/4	ATBZ12-02-□	NCU-ATBZ12-02	CS-ATBZ12-02	
	12	R3/8	ATBZ12-03-□	NCU-ATBZ12-03	CS-ATBZ12-03	
		R1/2	ATBZ12-04-□	NCU-ATBZ12-04	CS-ATBZ12-04	

* - □ ⇒ Select either blank (standard) or D (non-lubricant specification)

● Models of supply joints

Name	Tube outer diameter	Thread size	Standard model or non-lubricant specifications	NCU Specification	CS Specification
Reducer for bulkhead ASKR	4	M8×1	ASKR8-4	←	CS-ASKR8-4
	6	M8×1	ASKR8-6	←	CS-ASKR8-6
	6	M12×1	ASKR12-6	←	CS-ASKR12-6
	8	M12×1	ASKR12-8	←	CS-ASKR12-8
	10	M12×1	ASKR12-10	←	CS-ASKR12-10
	8	M14×1	ASKR14-8	←	CS-ASKR14-8
	10	M14×1	ASKR14-10	←	CS-ASKR14-10
	12	M14×1	ASKR14-12	←	CS-ASKR14-12
	12	M18×1	ASKR18-12	←	CS-ASKR18-12

QUICK FITTINGS(Smart type)

Straight

●ATS



(1 bag, 10 pcs.)

in
Tube size
0.157
0.236
0.315
0.394
0.472
0.630

Straight with hexagon socket

●ATSH



(1 bag, 10 pcs.)

in
Tube size
0.157
0.236
0.315
0.394
0.472

Female straight

●ATSM



(1 bag, 10 pcs.)

in
Tube size
0.157
0.236
0.315
0.394
0.472

Union for bulkhead

●AUK



Main unit: Aluminum alloy (black almite)
Nut: Mild steel (zinc plated)
(1 bag, 10 pcs.)

in
Tube size
0.157
0.236
0.315
0.394
0.472

Female union for bulkhead

●AUKM



Nut: Mild steel (zinc plated)
(1 bag, 10 pcs.)

in
Tube size
0.157
0.236
0.315
0.394
0.472

Elbow

●ATL



(1 bag, 10 pcs.)

in
Tube size
0.157
0.236
0.315
0.394
0.472

Long elbow

●ATLL



(1 bag, 10 pcs.)

in
Tube size
0.157
0.236
0.315
0.394
0.472

Tee

●ATT



(1 bag, 10 pcs.)

in
Tube size
0.157
0.236
0.315
0.394
0.472

Branch tee

●ATB



(1 bag, 10 pcs.)

in
Tube size
0.157
0.236
0.315
0.394
0.472

Branch Y

●ATBY



(1 bag, 10 pcs.)

in
Tube size
0.157
0.236
0.315
0.394
0.472

Branch elbow Y

●ATBLY



(1 bag, 10 pcs.)

in
Tube size
0.157
0.236
0.315
0.394
0.472

Branch double Y

●ATBW



(1 bag, 10 pcs.)

in
Tube size
0.157
0.236

QUICK FITTINGS(Smart type)

Branch triple

●ATBE



(1 bag, 10 pcs.)

in	
Tube size	
0.236	0.157
0.315	0.157
0.315	0.236
0.394	0.315

Branch triple double

●ATBEW



(1 bag, 10 pcs.)

in	
Tube size	
0.315	0.157
0.315	0.236
0.394	0.236
0.394	0.315

Branch tetra

●ATBZ



(1 bag, 10 pcs.)

in	
Tube size	
0.157	
0.236	
0.315	
0.394	
0.472	

Reducer for bulkhead

●ASKR



Main side thread size	Sub-main side tube size				
	in				
M8×1 (8)	0.157	0.236	0.315	0.394	0.472
M12×1 (12)	0.315-0.157	0.315-0.236	—	—	—
M14×1 (14)	—	0.472-0.236	0.472-0.315	0.472-0.394	—
M18×1 (18)	—	—	0.551-0.315	0.551-0.394	0.551-0.472
	—	—	—	—	0.709-0.472

Straight

●ATS



(1 bag, 10 pcs.)

Tube size
0.157
0.236
0.315
0.394
0.472
0.630

Order codes

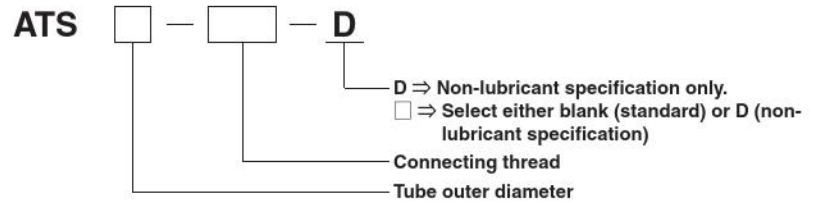

Dimensions in

Straight
ATS

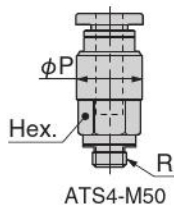
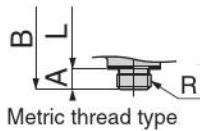
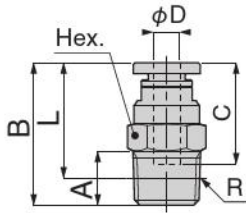

Model	Tube outer diameter φ D	R	A	B	L	C	Width across flats Hex.	φ P	Orifice diameter (φ in)	Mass oz
ATS4-M5-D	0.157	M5×0.8	0.110	0.780	0.669	0.587	0.394	-	0.094	0.198
ATS4-M50- <input type="checkbox"/>	0.157	M5×0.8	0.110	0.894	0.783	0.587	0.315	0.382	0.094	0.215
ATS4-M6-D	0.157	M6×1	0.150	0.819	0.669	0.587	0.394	-	0.118	0.212
ATS4-01-D	0.157	R1/8	0.315	0.827	0.669	0.587	0.394	-	0.118	0.261
ATS4-02- <input type="checkbox"/>	0.157	R1/4	0.433	0.886	0.650	0.587	0.551	-	0.118	0.564
ATS6-M5-D	0.236	M5×0.8	0.110	0.862	0.752	0.669	0.472	-	0.094	0.286
ATS6-M6-D	0.236	M6×1	0.150	0.902	0.752	0.669	0.472	-	0.118	0.300
ATS6-01-D	0.236	R1/8	0.315	0.878	0.720	0.669	0.472	-	0.197	0.289
ATS6-02- <input type="checkbox"/>	0.236	R1/4	0.433	0.933	0.693	0.669	0.551	-	0.197	0.529
ATS6-03- <input type="checkbox"/>	0.236	R3/8	0.472	0.965	0.713	0.669	0.669	-	0.197	0.988
ATS8-01- <input type="checkbox"/>	0.315	R1/8	0.315	1.098	0.941	0.717	0.551	-	0.236	0.494
ATS8-02- <input type="checkbox"/>	0.315	R1/4	0.433	1.047	0.811	0.717	0.551	-	0.276	0.494
ATS8-03- <input type="checkbox"/>	0.315	R3/8	0.472	1.004	0.756	0.717	0.669	-	0.276	0.882
ATS10-01- <input type="checkbox"/>	0.394	R1/8	0.315	1.193	1.035	0.815	0.669	-	0.236	0.741
ATS10-02- <input type="checkbox"/>	0.394	R1/4	0.433	1.173	0.937	0.815	0.669	-	0.335	0.670
ATS10-03- <input type="checkbox"/>	0.394	R3/8	0.472	1.154	0.906	0.815	0.669	-	0.354	0.847
ATS10-04- <input type="checkbox"/>	0.394	R1/2	0.591	1.197	0.874	0.815	0.827	-	0.354	1.623
ATS12-02- <input type="checkbox"/>	0.472	R1/4	0.433	1.413	1.177	0.917	0.827	-	0.335	1.305
ATS12-03- <input type="checkbox"/>	0.472	R3/8	0.472	1.256	1.008	0.917	0.827	-	0.433	1.058
ATS12-04- <input type="checkbox"/>	0.472	R1/2	0.591	1.335	1.012	0.917	0.827	-	0.433	1.552
ATS16-03- <input type="checkbox"/>	0.630	R3/8	0.472	1.547	1.299	0.976	0.945	-	0.433	1.905
ATS16-04- <input type="checkbox"/>	0.630	R1/2	0.591	1.626	1.303	0.976	0.945	-	0.512	2.222

* -D ⇒ Non-lubricant specification only. - ⇒ Select either blank (standard) or D (non-lubricant specification)

* The L dimension for the tapered thread types is a reference dimension when mated and tightened.

Straight with hexagon socket

● ATSH



(1 bag, 10 pcs.)

Tube size
0.157
0.236
0.315
0.394
0.472

Order codes

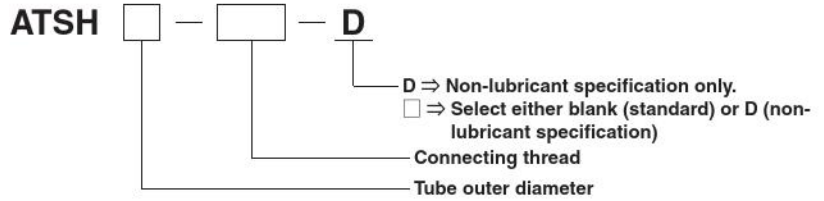

Dimensions in

Straight with hexagon socket
ATSH

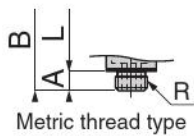
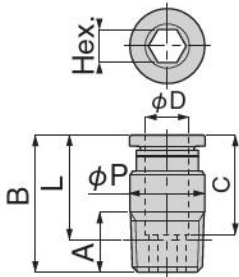

Model	Tube outer diameter φ D	R	A	B	L	C	Width across flats Hex.	φ P	Orifice diameter (φ in)	Mass oz
ATSH4-M5-D	0.157	M5×0.8	0.110	0.776	0.665	0.587	0.098	0.382	0.102	0.162
ATSH4-M6-D	0.157	M6×1	0.150	0.815	0.665	0.587	0.098	0.382	0.102	0.190
ATSH4-01-D	0.157	R1/8	0.315	0.787	0.630	0.587	0.098	0.382	0.102	0.233
ATSH6-M5-D	0.236	M5×0.8	0.110	0.839	0.728	0.669	0.098	0.465	0.102	0.198
ATSH6-M6-D	0.236	M6×1	0.150	0.878	0.728	0.669	0.118	0.465	0.126	0.222
ATSH6-01-D	0.236	R1/8	0.315	0.870	0.713	0.669	0.157	0.465	0.165	0.268
ATSH6-02-□	0.236	R1/4	0.433	0.839	0.598	0.669	0.157	0.539	0.165	0.459
ATSH8-01-□	0.315	R1/8	0.315	1.020	0.862	0.717	0.197	0.539	0.209	0.310
ATSH8-02-□	0.315	R1/4	0.433	0.988	0.752	0.717	0.236	0.539	0.248	0.459
ATSH8-03-□	0.315	R3/8	0.472	0.874	0.626	0.717	0.236	0.661	0.248	0.670
ATSH10-02-□	0.394	R1/4	0.433	1.173	0.937	0.815	0.236	0.689	0.248	0.705
ATSH10-03-□	0.394	R3/8	0.472	1.154	0.906	0.815	0.236	0.689	0.248	0.917
ATSH10-04-□	0.394	R1/2	0.591	1.193	0.870	0.815	0.236	0.819	0.248	1.587
ATSH12-03-□	0.472	R3/8	0.472	1.256	1.008	0.917	0.315	0.819	0.331	1.093
ATSH12-04-□	0.472	R1/2	0.591	1.335	1.012	0.917	0.315	0.819	0.331	1.587

* Changed width across flats of inner diameter of hex nut and diameter of orifice to correct the problem of lock hook interference with hex wrench.

* -D ⇒ Non-lubricant specification only. - □ ⇒ Select either blank (standard) or D (non-lubricant specification)

* The L dimension for the tapered thread types is a reference dimension when mated and tightened.

Female straight

● ATSM



(1 bag, 10 pcs.)

Tube size
0.157
0.236
0.315
0.394
0.472

Order codes

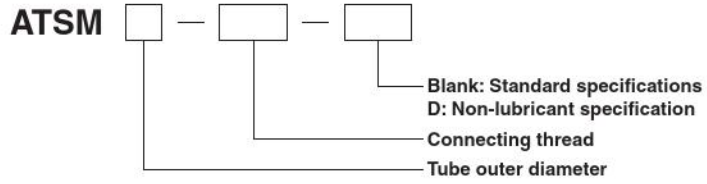

Dimensions in

Female straight
ATSM

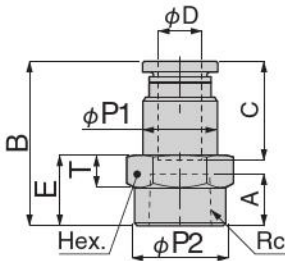

Model	Tube outer diameter ϕD	Rc	A	B	E	$\phi P1$	$\phi P2$	C	Width across flats Hex.	T	Orifice diameter (ϕ in)	Mass oz
ATSM4-01- <input type="checkbox"/>	0.157	Rc1/8	0.276	0.941	0.394	0.382	0.543	0.587	0.551	0.197	0.118	0.459
ATSM4-02- <input type="checkbox"/>	0.157	Rc1/4	0.374	1.059	0.512	0.382	0.661	0.587	0.669	0.236	0.118	0.670
ATSM6-01- <input type="checkbox"/>	0.236	Rc1/8	0.276	1.024	0.394	0.465	0.543	0.669	0.551	0.197	0.197	0.529
ATSM6-02- <input type="checkbox"/>	0.236	Rc1/4	0.374	1.142	0.512	0.465	0.661	0.669	0.669	0.236	0.197	0.741
ATSM8-01- <input type="checkbox"/>	0.315	Rc1/8	0.276	1.071	0.394	0.539	0.543	0.717	0.551	0.197	0.276	0.564
ATSM8-02- <input type="checkbox"/>	0.315	Rc1/4	0.374	1.189	0.512	0.539	0.661	0.717	0.669	0.236	0.276	0.776
ATSM8-03- <input type="checkbox"/>	0.315	Rc3/8	0.413	1.228	0.551	0.539	0.819	0.717	0.827	0.256	0.276	1.058
ATSM10-02- <input type="checkbox"/>	0.394	Rc1/4	0.374	1.287	0.512	0.689	0.661	0.815	0.669	0.236	0.354	0.988
ATSM10-03- <input type="checkbox"/>	0.394	Rc3/8	0.413	1.327	0.551	0.689	0.819	0.815	0.827	0.256	0.354	1.305
ATSM12-02- <input type="checkbox"/>	0.472	Rc1/4	0.374	1.370	0.531	0.819	0.661	0.917	0.827	0.256	0.433	1.482
ATSM12-03- <input type="checkbox"/>	0.472	Rc3/8	0.413	1.429	0.551	0.819	0.819	0.917	0.827	0.256	0.433	1.552

* - \Rightarrow Select either blank (standard) or D (non-lubricant specification)

● AUK



Main unit: Aluminum alloy (black almite)
 Nut: Mild steel (zinc plated)
 (1 bag, 10 pcs.)

Tube size
0.157
0.236
0.315
0.394
0.472

Order codes

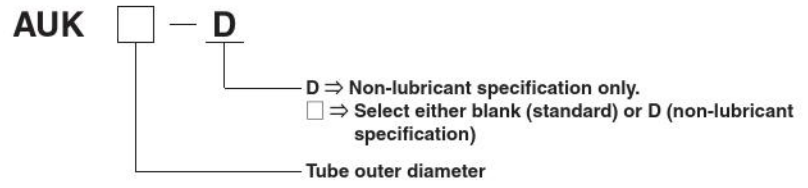

Dimensions in

Union for bulkhead
 AUK



Model	Tube outer diameter ϕD	M	B	E	A	ϕP	C	Width across flats Hex.	T	Orifice diameter (ϕ in)	Mass oz
AUK4-D	0.157	M12×1	1.213	0.374	0.583	0.425	0.587	0.551	0.157	0.118	0.388
AUK6-D	0.236	M14×1	1.374	0.374	0.748	0.492	0.669	0.669	0.157	0.197	0.564
AUK8- <input type="checkbox"/>	0.315	M16×1	1.472	0.413	0.764	0.575	0.717	0.748	0.157	0.276	0.670
AUK10- <input type="checkbox"/>	0.394	M20×1	1.669	0.469	0.850	0.728	0.815	0.945	0.197	0.354	1.235
AUK12- <input type="checkbox"/>	0.472	M22×1	1.874	0.520	0.953	0.803	0.917	1.063	0.236	0.433	1.834

* -D ⇒ Non-lubricant specification only. - ⇒ Select either blank (standard) or D (non-lubricant specification)

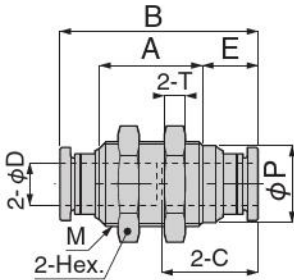

● AUKM



Nut: Mild steel (zinc plated)

(1 bag, 10 pcs.)

Tube size
0.157
0.236
0.315
0.394
0.472

Order codes

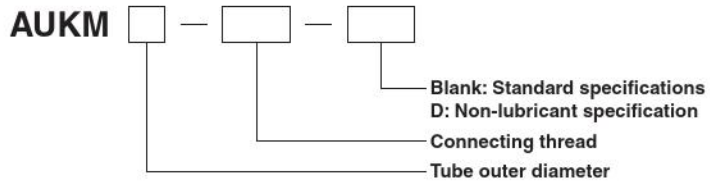

Dimensions in

Female union for bulkhead
 AUKM

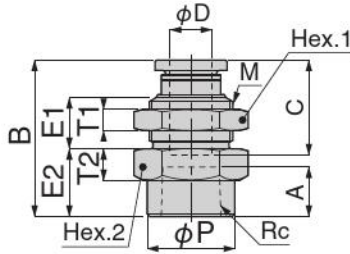

Model	Tube outer diameter ϕD	Rc	M	B	E1	E2	A	C	ϕP	Width across flats Hex.1	Width across flats Hex.2	T1	T2	Orifice diameter (ϕ in)	Mass oz
AUKM4-01- <input type="text"/>	0.157	Rc1/8	M12 × 1	0.953	0.354	0.354	0.276	0.587	0.543	0.551	0.551	0.157	0.197	0.118	0.600
AUKM6-01- <input type="text"/>	0.236	Rc1/8	M14 × 1	1.039	0.402	0.394	0.276	0.669	0.543	0.669	0.669	0.157	0.236	0.197	0.882
AUKM6-02- <input type="text"/>	0.236	Rc1/4	M14 × 1	1.130	0.402	0.484	0.374	0.669	0.661	0.669	0.669	0.157	0.236	0.197	0.917
AUKM8-01- <input type="text"/>	0.315	Rc1/8	M16 × 1	1.063	0.386	0.394	0.276	0.717	0.543	0.748	0.748	0.157	0.236	0.276	1.058
AUKM8-02- <input type="text"/>	0.315	Rc1/4	M16 × 1	1.181	0.386	0.512	0.374	0.717	0.661	0.748	0.748	0.157	0.236	0.276	1.129
AUKM8-03- <input type="text"/>	0.315	Rc3/8	M16 × 1	1.220	0.386	0.551	0.413	0.717	0.768	0.748	0.748	0.157	0.236	0.276	1.058
AUKM10-02- <input type="text"/>	0.394	Rc1/4	M20 × 1	1.287	0.437	0.512	0.374	0.815	0.661	0.945	0.945	0.197	0.276	0.354	1.940
AUKM10-03- <input type="text"/>	0.394	Rc3/8	M20 × 1	1.327	0.437	0.551	0.413	0.815	0.819	0.945	0.945	0.197	0.276	0.354	1.975
AUKM12-03- <input type="text"/>	0.472	Rc3/8	M22 × 1	1.429	0.488	0.551	0.413	0.917	0.819	1.063	0.945	0.236	0.276	0.433	2.293
AUKM12-04- <input type="text"/>	0.472	Rc1/2	M22 × 1	1.547	0.488	0.669	0.512	0.917	0.984	1.063	0.945	0.236	0.276	0.433	2.363

* - ⇒ Select either blank (standard) or D (non-lubricant specification)

●ATL



Tube size
0.157
0.236
0.315
0.394
0.472

(1 bag, 10 pcs.)

Order codes

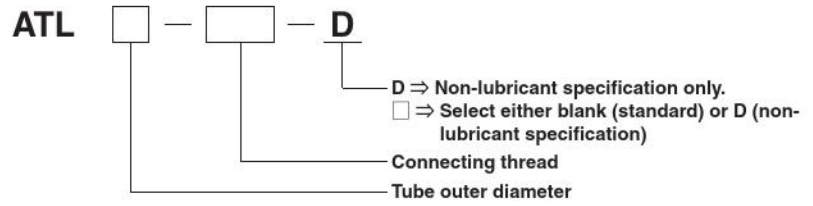

Dimensions in

Elbow
ATL

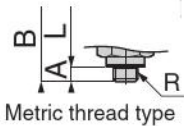
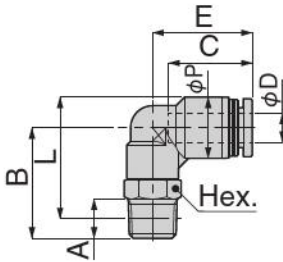

Model	Tube outer diameter φ D	R	A	B	L	φ P	C	E	Width across flats Hex.	Orifice diameter (φin)	Mass oz
ATL4-M5-D	0.157	M5×0.8	0.110	0.630	0.717	0.394	0.587	0.697	0.315	0.094	0.201
ATL4-M6-D	0.157	M6×1	0.150	0.787	0.835	0.394	0.587	0.736	0.394	0.094	0.282
ATL4-01-D	0.157	R1/8	0.315	0.866	0.906	0.394	0.587	0.736	0.394	0.110	0.353
ATL4-02- <input type="checkbox"/>	0.157	R1/4	0.433	1.142	1.102	0.394	0.587	0.815	0.551	0.110	0.635
ATL6-M5-D	0.236	M5×0.8	0.110	0.768	0.906	0.492	0.669	0.799	0.394	0.094	0.314
ATL6-M6-D	0.236	M6×1	0.150	0.807	0.906	0.492	0.669	0.799	0.394	0.118	0.282
ATL6-01-D	0.236	R1/8	0.315	0.886	0.976	0.492	0.669	0.799	0.394	0.169	0.388
ATL6-02- <input type="checkbox"/>	0.236	R1/4	0.433	1.102	1.110	0.492	0.669	0.858	0.551	0.169	0.670
ATL6-03- <input type="checkbox"/>	0.236	R3/8	0.472	1.240	1.236	0.492	0.669	0.937	0.669	0.169	1.058
ATL8-01- <input type="checkbox"/>	0.315	R1/8	0.315	0.945	1.075	0.571	0.713	0.894	0.472	0.236	0.494
ATL8-02- <input type="checkbox"/>	0.315	R1/4	0.433	1.102	1.150	0.571	0.713	0.933	0.551	0.264	0.705
ATL8-03- <input type="checkbox"/>	0.315	R3/8	0.472	1.220	1.256	0.571	0.713	0.972	0.669	0.264	1.093
ATL10-01- <input type="checkbox"/>	0.394	R1/8	0.315	0.984	1.173	0.689	0.795	1.004	0.472	0.236	0.635
ATL10-02- <input type="checkbox"/>	0.394	R1/4	0.433	1.122	1.228	0.689	0.795	1.024	0.551	0.315	0.811
ATL10-03- <input type="checkbox"/>	0.394	R3/8	0.472	1.260	1.354	0.689	0.795	1.063	0.669	0.327	1.199
ATL10-04- <input type="checkbox"/>	0.394	R1/2	0.591	1.417	1.441	0.689	0.795	1.083	0.827	0.327	2.011
ATL12-02- <input type="checkbox"/>	0.472	R1/4	0.433	1.173	1.346	0.827	0.921	1.142	0.551	0.315	0.952
ATL12-03- <input type="checkbox"/>	0.472	R3/8	0.472	1.280	1.445	0.827	0.921	1.169	0.669	0.394	1.340
ATL12-04- <input type="checkbox"/>	0.472	R1/2	0.591	1.437	1.528	0.827	0.921	1.209	0.827	0.406	2.152

* -D ⇒ Non-lubricant specification only. - ⇒ Select either blank (standard) or D (non-lubricant specification)

* The L dimension for the tapered thread types is a reference dimension when mated and tightened.

Long elbow

● ATLL



Tube size
0.157
0.236
0.315
0.394
0.472

(1 bag, 10 pcs.)

Order codes

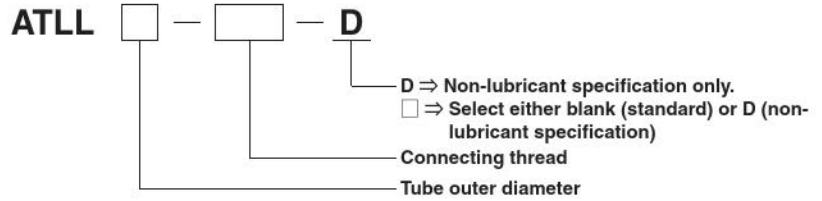

Dimensions in

Long elbow
ATLL

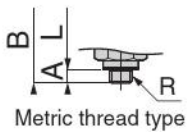
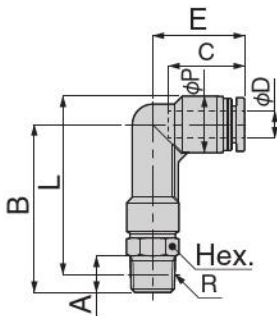

Model	Tube outer diameter φ D	R	A	B	L	φ P	C	E	Width across flats Hex.	Orifice diameter (φin)	Mass oz
ATLL4-M5-D	0.157	M5×0.8	0.110	1.102	1.189	0.394	0.587	0.736	0.315	0.094	0.226
ATLL4-01-D	0.157	R1/8	0.315	1.339	1.378	0.394	0.587	0.736	0.394	0.110	0.388
ATLL6-01-D	0.236	R1/8	0.315	1.457	1.547	0.492	0.669	0.799	0.394	0.169	0.459
ATLL6-02- <input type="checkbox"/>	0.236	R1/4	0.433	1.673	1.681	0.492	0.669	0.858	0.551	0.169	0.705
ATLL6-03- <input type="checkbox"/>	0.236	R3/8	0.472	1.811	1.807	0.492	0.669	0.937	0.669	0.169	1.164
ATLL8-01- <input type="checkbox"/>	0.315	R1/8	0.315	1.594	1.724	0.571	0.713	0.894	0.472	0.236	0.564
ATLL8-02- <input type="checkbox"/>	0.315	R1/4	0.433	1.752	1.799	0.571	0.713	0.933	0.551	0.264	0.776
ATLL8-03- <input type="checkbox"/>	0.315	R3/8	0.472	1.870	1.906	0.571	0.713	0.972	0.669	0.264	1.235
ATLL10-02- <input type="checkbox"/>	0.394	R1/4	0.433	1.890	1.996	0.689	0.795	1.024	0.551	0.315	0.917
ATLL10-03- <input type="checkbox"/>	0.394	R3/8	0.472	2.028	2.122	0.689	0.795	1.063	0.669	0.327	1.340
ATLL10-04- <input type="checkbox"/>	0.394	R1/2	0.591	2.185	2.209	0.689	0.795	1.063	0.827	0.327	2.222
ATLL12-02- <input type="checkbox"/>	0.472	R1/4	0.433	2.079	2.252	0.827	0.921	1.142	0.551	0.315	1.058
ATLL12-03- <input type="checkbox"/>	0.472	R3/8	0.472	2.185	2.350	0.827	0.921	1.169	0.669	0.394	1.482
ATLL12-04- <input type="checkbox"/>	0.472	R1/2	0.591	2.343	2.433	0.827	0.921	1.169	0.827	0.406	2.399

* -D ⇒ Non-lubricant specification only. - ⇒ Select either blank (standard) or D (non-lubricant specification)

* The L dimension for the tapered thread types is a reference dimension when mated and tightened.

Tee

●ATT



Tube size

0.157
0.236
0.315
0.394
0.472

(1 bag, 10 pcs.)

Order codes

ATT

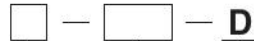

D ⇒ Non-lubricant specification only.

□ ⇒ Select either blank (standard) or D (non-lubricant specification)

Connecting thread

Tube outer diameter

Dimensions in

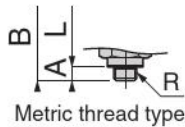
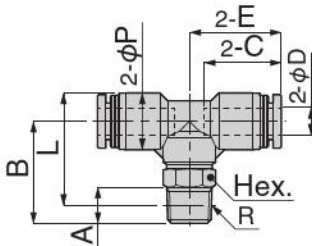
Tee
ATT

Metric thread type

Model	Tube outer diameter ϕD	R	A	B	L	ϕP	C	E	Width across flats Hex.	Orifice diameter (ϕ in)	Mass oz
ATT4-M5-D	0.157	M5×0.8	0.110	0.630	0.717	0.394	0.587	0.697	0.315	0.094	0.282
ATT4-M6-D	0.157	M6×1	0.150	0.787	0.835	0.394	0.587	0.736	0.394	0.094	0.388
ATT4-01-D	0.157	R1/8	0.315	0.866	0.906	0.394	0.587	0.736	0.394	0.110	0.459
ATT4-02-□	0.157	R1/4	0.433	1.142	1.102	0.394	0.587	0.815	0.551	0.110	0.705
ATT6-M5-D	0.236	M5×0.8	0.110	0.768	0.906	0.492	0.669	0.797	0.394	0.094	0.423
ATT6-M6-D	0.236	M6×1	0.150	0.807	0.906	0.492	0.669	0.797	0.394	0.118	0.459
ATT6-01-D	0.236	R1/8	0.315	0.886	0.976	0.492	0.669	0.797	0.394	0.169	0.494
ATT6-02-□	0.236	R1/4	0.433	1.102	1.110	0.492	0.669	0.856	0.551	0.169	0.776
ATT6-03-□	0.236	R3/8	0.472	1.240	1.236	0.492	0.669	0.935	0.669	0.169	1.164
ATT8-01-□	0.315	R1/8	0.315	0.945	1.075	0.571	0.713	0.894	0.472	0.236	0.670
ATT8-02-□	0.315	R1/4	0.433	1.102	1.150	0.571	0.713	0.933	0.551	0.264	0.882
ATT8-03-□	0.315	R3/8	0.472	1.220	1.256	0.571	0.713	0.972	0.669	0.264	1.235
ATT10-02-□	0.394	R1/4	0.433	1.122	1.228	0.689	0.795	1.024	0.551	0.315	1.093
ATT10-03-□	0.394	R3/8	0.472	1.260	1.354	0.689	0.795	1.063	0.669	0.327	1.482
ATT10-04-□	0.394	R1/2	0.591	1.417	1.441	0.689	0.795	1.083	0.827	0.327	2.293
ATT12-02-□	0.472	R1/4	0.433	1.173	1.346	0.827	0.921	1.140	0.551	0.315	1.340
ATT12-03-□	0.472	R3/8	0.472	1.280	1.445	0.827	0.921	1.169	0.669	0.394	1.693
ATT12-04-□	0.472	R1/2	0.591	1.437	1.528	0.827	0.921	1.209	0.827	0.406	2.540

* -D ⇒ Non-lubricant specification only. - □ ⇒ Select either blank (standard) or D (non-lubricant specification)

* The L dimension for the tapered thread types is a reference dimension when mated and tightened.

● **ATB**



(1 bag, 10 pcs.)

Tube size
0.157
0.236
0.315
0.394
0.472

Order codes

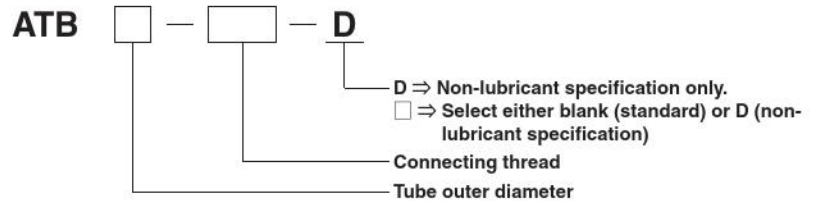

Dimensions in

Branch tee
ATB

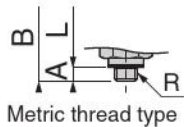
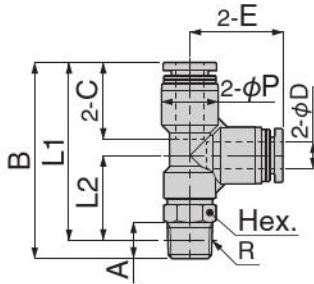

Model	Tube outer diameter φD	R	A	B	L1	L2	φP	C	E	Width across flats Hex.	Orifice diameter (φin)	Mass oz
ATB4-M5-D	0.157	M5×0.8	0.110	1.327	1.217	0.539	0.394	0.587	0.677	0.315	0.094	0.275
ATB4-M6-D	0.157	M6×1	0.150	1.504	1.354	0.677	0.394	0.587	0.677	0.394	0.094	0.388
ATB4-01-D	0.157	R1/8	0.315	1.583	1.425	0.748	0.394	0.587	0.677	0.394	0.110	0.459
ATB4-02- <input type="checkbox"/>	0.157	R1/4	0.433	1.819	1.583	0.906	0.394	0.587	0.756	0.551	0.110	0.705
ATB6-M5-D	0.236	M5×0.8	0.110	1.587	1.476	0.669	0.492	0.669	0.807	0.394	0.094	0.423
ATB6-M6-D	0.236	M6×1	0.150	1.626	1.476	0.669	0.492	0.669	0.807	0.394	0.118	0.423
ATB6-01-D	0.236	R1/8	0.315	1.705	1.547	0.740	0.492	0.669	0.807	0.394	0.169	0.494
ATB6-02- <input type="checkbox"/>	0.236	R1/4	0.433	1.921	1.681	0.874	0.492	0.669	0.807	0.551	0.169	0.776
ATB6-03- <input type="checkbox"/>	0.236	R3/8	0.472	2.047	1.799	0.992	0.492	0.669	0.846	0.669	0.169	1.129
ATB8-01- <input type="checkbox"/>	0.315	R1/8	0.315	1.846	1.689	0.787	0.571	0.713	0.902	0.472	0.236	0.670
ATB8-02- <input type="checkbox"/>	0.315	R1/4	0.433	2.035	1.799	0.898	0.571	0.713	0.902	0.551	0.264	0.882
ATB8-03- <input type="checkbox"/>	0.315	R3/8	0.472	2.181	1.933	1.031	0.571	0.713	0.902	0.669	0.264	1.235
ATB10-02- <input type="checkbox"/>	0.394	R1/4	0.433	2.154	1.917	0.886	0.689	0.795	1.031	0.551	0.315	1.093
ATB10-03- <input type="checkbox"/>	0.394	R3/8	0.472	2.291	2.043	1.012	0.689	0.795	1.031	0.669	0.327	1.482
ATB10-04- <input type="checkbox"/>	0.394	R1/2	0.591	2.449	2.126	1.094	0.689	0.795	1.075	0.827	0.327	2.293
ATB12-02- <input type="checkbox"/>	0.472	R1/4	0.433	2.374	2.134	0.933	0.827	0.921	1.181	0.551	0.315	1.340
ATB12-03- <input type="checkbox"/>	0.472	R3/8	0.472	2.500	2.252	1.051	0.827	0.921	1.201	0.669	0.394	1.693
ATB12-04- <input type="checkbox"/>	0.472	R1/2	0.591	2.657	2.335	1.134	0.827	0.921	1.209	0.827	0.406	2.540

* -D ⇒ Non-lubricant specification only. - ⇒ Select either blank (standard) or D (non-lubricant specification)

* The L dimension for the tapered thread types is a reference dimension when mated and tightened.

● ATBY



Tube size
0.157
0.236
0.315
0.394
0.472

(1 bag, 10 pcs.)

Order codes

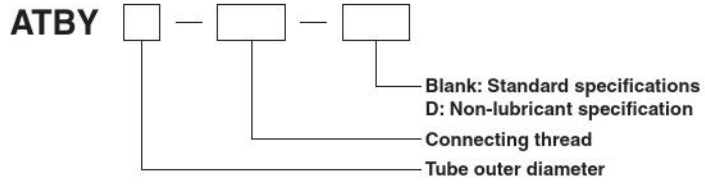

Dimensions in

Branch Y
ATBY

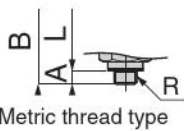
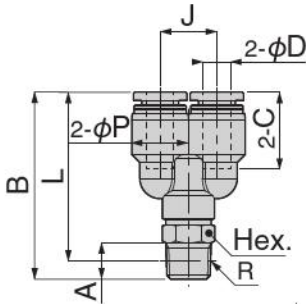

Model	Tube outer diameter ϕD	R	A	B	L	ϕP	C	J	Width across flats Hex.	Orifice diameter (ϕ in)	Mass oz
ATBY4-M5- <input type="checkbox"/>	0.157	M5×0.8	0.110	1.295	1.185	0.394	0.587	0.406	0.315	0.094	0.282
ATBY4-01- <input type="checkbox"/>	0.157	R1/8	0.315	1.512	1.354	0.394	0.587	0.406	0.394	0.110	0.459
ATBY4-02- <input type="checkbox"/>	0.157	R1/4	0.433	1.709	1.472	0.394	0.587	0.406	0.551	0.110	0.705
ATBY6-M5- <input type="checkbox"/>	0.236	M5×0.8	0.110	1.508	1.398	0.492	0.669	0.492	0.394	0.094	0.459
ATBY6-M6- <input type="checkbox"/>	0.236	M6×1	0.150	1.547	1.398	0.492	0.669	0.492	0.394	0.118	0.459
ATBY6-01- <input type="checkbox"/>	0.236	R1/8	0.315	1.626	1.469	0.492	0.669	0.492	0.394	0.169	0.529
ATBY6-02- <input type="checkbox"/>	0.236	R1/4	0.433	1.902	1.661	0.492	0.669	0.492	0.551	0.169	0.776
ATBY6-03- <input type="checkbox"/>	0.236	R3/8	0.472	2.020	1.768	0.492	0.669	0.492	0.669	0.169	1.164
ATBY8-01- <input type="checkbox"/>	0.315	R1/8	0.315	1.815	1.657	0.571	0.713	0.571	0.472	0.236	0.705
ATBY8-02- <input type="checkbox"/>	0.315	R1/4	0.433	1.941	1.705	0.571	0.713	0.571	0.551	0.264	0.882
ATBY8-03- <input type="checkbox"/>	0.315	R3/8	0.472	2.067	1.819	0.571	0.713	0.571	0.669	0.264	1.270
ATBY10-02- <input type="checkbox"/>	0.394	R1/4	0.433	2.110	1.874	0.689	0.795	0.689	0.551	0.315	1.129
ATBY10-03- <input type="checkbox"/>	0.394	R3/8	0.472	2.232	1.984	0.689	0.795	0.689	0.669	0.327	1.517
ATBY10-04- <input type="checkbox"/>	0.394	R1/2	0.591	2.370	2.047	0.689	0.795	0.689	0.827	0.327	2.328
ATBY12-02- <input type="checkbox"/>	0.472	R1/4	0.433	2.307	2.071	0.827	0.921	0.827	0.551	0.315	1.411
ATBY12-03- <input type="checkbox"/>	0.472	R3/8	0.472	2.386	2.138	0.827	0.921	0.827	0.669	0.394	1.799
ATBY12-04- <input type="checkbox"/>	0.472	R1/2	0.591	2.547	2.224	0.827	0.921	0.827	0.827	0.406	2.610

* - ⇒ Select either blank (standard) or D (non-lubricant specification)

* The L dimension for the tapered thread types is a reference dimension when mated and tightened.

● **ATBLY**



(1 bag, 10 pcs.)

Tube size
0.157
0.236
0.315
0.394
0.472

Order codes

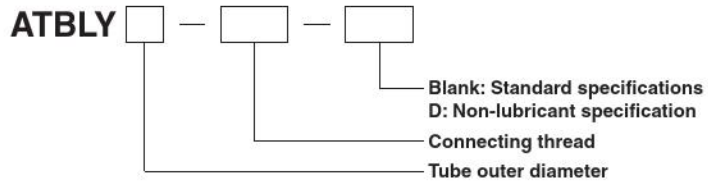

Dimensions in

**Branch elbow Y
ATBLY**



Model	Tube outer diameter ϕD	R	A	B	L	ϕP	C	J	E	Width across flats Hex.	Orifice diameter (ϕ in)	Mass oz
ATBLY4-M5 - <input type="checkbox"/>	0.157	M5×0.8	0.110	0.787	0.874	0.394	0.587	0.406	0.716	0.394	0.094	0.388
ATBLY4-M6 - <input type="checkbox"/>	0.157	M6×1	0.150	0.827	0.874	0.394	0.587	0.406	0.716	0.394	0.118	0.38
ATBLY4-01 - <input type="checkbox"/>	0.157	R1/8	0.315	0.906	0.945	0.394	0.587	0.406	0.716	0.394	0.154	0.459
ATBLY4-02 - <input type="checkbox"/>	0.157	R1/4	0.433	1.063	1.024	0.394	0.587	0.406	0.756	0.551	0.154	0.705
ATBLY6-M5 - <input type="checkbox"/>	0.236	M5×0.8	0.110	0.807	0.945	0.492	0.669	0.492	0.756	0.394	0.094	0.423
ATBLY6-M6 - <input type="checkbox"/>	0.236	M6×1	0.150	0.846	0.945	0.492	0.669	0.492	0.756	0.394	0.118	0.459
ATBLY6-01 - <input type="checkbox"/>	0.236	R1/8	0.315	0.925	1.016	0.492	0.669	0.492	0.756	0.394	0.165	0.529
ATBLY6-02 - <input type="checkbox"/>	0.236	R1/4	0.433	1.142	1.150	0.492	0.669	0.492	0.858	0.551	0.209	0.776
ATBLY6-03 - <input type="checkbox"/>	0.236	R3/8	0.472	1.240	1.236	0.492	0.669	0.492	0.937	0.669	0.209	1.199
ATBLY8-01 - <input type="checkbox"/>	0.315	R1/8	0.315	0.984	1.114	0.571	0.713	0.571	0.894	0.472	0.224	0.705
ATBLY8-02 - <input type="checkbox"/>	0.315	R1/4	0.433	1.142	1.189	0.571	0.713	0.571	0.933	0.551	0.287	0.882
ATBLY8-03 - <input type="checkbox"/>	0.315	R3/8	0.472	1.260	1.295	0.571	0.713	0.571	0.972	0.670	0.287	1.305
ATBLY10-02 - <input type="checkbox"/>	0.394	R1/4	0.433	1.161	1.268	0.689	0.795	0.689	1.024	0.551	0.315	1.129
ATBLY10-03 - <input type="checkbox"/>	0.394	R3/8	0.472	1.280	1.374	0.689	0.795	0.689	1.063	0.670	0.362	1.517
ATBLY10-04 - <input type="checkbox"/>	0.394	R1/2	0.590	1.457	1.480	0.689	0.795	0.689	1.102	0.827	0.362	2.328
ATBLY12-02 - <input type="checkbox"/>	0.472	R1/4	0.433	1.161	1.339	0.827	0.921	0.827	1.110	0.551	0.315	1.376
ATBLY12-03 - <input type="checkbox"/>	0.472	R3/8	0.472	1.319	1.484	0.827	0.921	0.827	1.150	0.670	0.382	1.799
ATBLY12-04 - <input type="checkbox"/>	0.472	R1/2	0.591	1.496	1.587	0.827	0.921	0.827	1.189	0.827	0.417	2.610

* - ⇒ Select either blank (standard) or D (non-lubricant specification)

* The L dimension for the tapered thread types is a reference dimension when mated and tightened.

* Prices are the same.

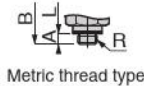
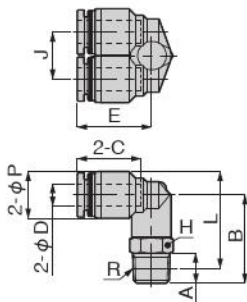

Branch double Y

● **ATBW**



(1 bag, 10 pcs.)

Tube size
0.157
0.236

Order codes

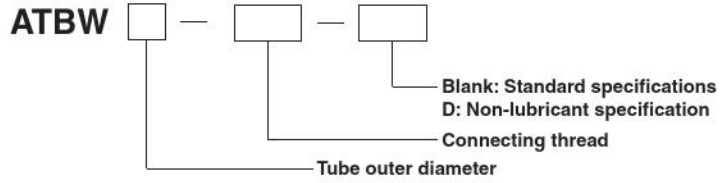

Dimensions in

**Branch double Y
ATBW**



Model	Tube outer diameter ϕD	R	A	B	L	ϕP	C	J	Width across flats Hex.	Orifice diameter (ϕ in)	Mass oz
ATBW4-01- <input type="checkbox"/>	0.157	R1/8	0.315	1.531	1.374	0.413	0.587	0.406	0.472	0.102	0.564
ATBW4-02- <input type="checkbox"/>	0.157	R1/4	0.433	1.670	1.433	0.413	0.587	0.406	0.472	0.102	0.741
ATBW6-01- <input type="checkbox"/>	0.236	R1/8	0.315	1.858	1.701	0.512	0.670	0.492	0.472	0.205	0.882

* - \Rightarrow Select either blank (standard) or D (non-lubricant specification)

* The L dimension for the tapered thread types is a reference dimension when mated and tightened.

* Prices are the same.

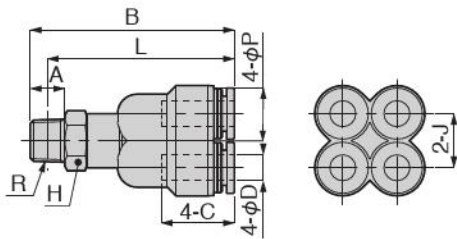

Branch triple

● ATBE



Tube size
0.236-0.157
0.315-0.157
0.315-0.236
0.394-0.315

(1 bag, 10 pcs.)

Order codes

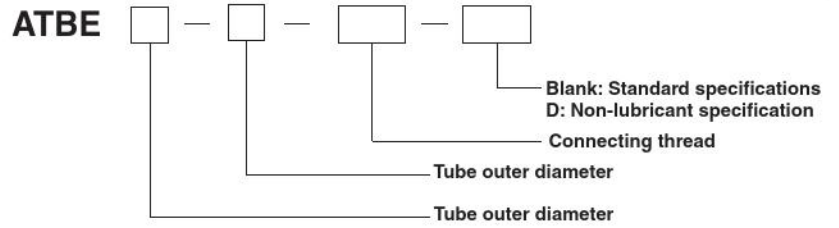

Dimensions in

Branch triple
ATBE

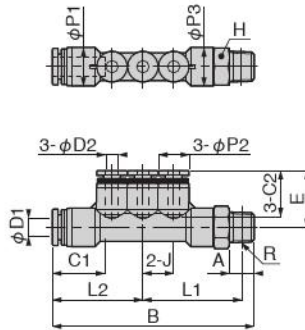

Model	Tube outer diameter $\phi D1$	Tube outer diameter $\phi D2$	R	A	B	E	L1	L2	J	$\phi P1$	$\phi P2$	$\phi P3$	C1	C2	Width across flats Hex.	Orifice diameter (ϕ in)	Mass oz
ATBE6-4-01-□	0.236	0.157	R1/8	0.315	2.575	0.724	1.264	1.534	0.394	0.492	0.394	0.492	0.669	0.587	0.472	0.118	0.741
ATBE8-4-02-□	0.315	0.157	R1/4	0.433	2.724	0.756	1.260	1.228	0.394	0.571	0.394	0.571	0.713	0.587	0.551	0.118	0.988
ATBE8-6-02-□	0.315	0.236	R1/4	0.433	3.028	0.839	1.437	1.354	0.492	0.571	0.492	0.571	0.713	0.670	0.551	0.181	1.235
ATBE10-8-03-□	0.394	0.315	R3/8	0.472	3.457	0.933	1.634	1.575	0.571	0.689	0.571	0.709	0.795	0.713	0.670	0.264	1.764

* - □ ⇒ Select either blank (standard) or D (non-lubricant specification)

* The L1 dimension for the tapered thread types is a reference dimension when mated and tightened.

* Prices are the same.

● **ATBEW**



(1 bag, 10 pcs.)

Tube size
0.315-0.157
0.315-0.236
0.394-0.236
0.394-0.315

Order codes

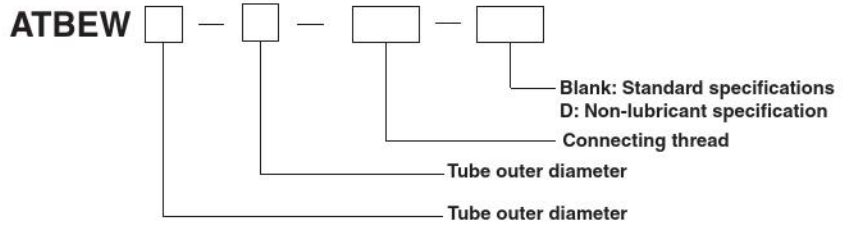

Dimensions in

**Branch triple double
ATBEW**

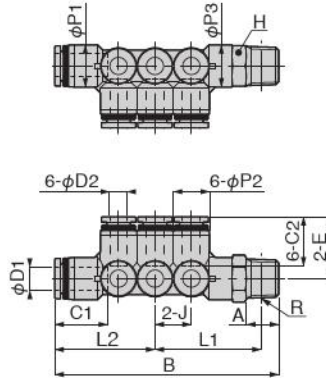

Model	Tube outer diameter $\phi D1$	Tube outer diameter $\phi D2$	R	A	B	E	L1	L2	J	$\phi P1$	$\phi P2$	$\phi P3$	C1	C2	Width across flats Hex.	Orifice diameter (ϕ in)	Mass oz
ATBEW8-4-02- <input type="checkbox"/>	0.315	0.157	R1/4	0.433	2.724	0.756	1.260	1.228	0.394	0.571	0.394	0.571	0.713	14.9	0.551	0.118	1.129
ATBEW8-4-03- <input type="checkbox"/>	0.315	0.157	R3/8	0.472	2.843	0.756	1.366	1.228	0.394	0.571	0.394	0.709	0.713	14.9	0.669	0.118	1.623
ATBEW8-6-02- <input type="checkbox"/>	0.315	0.236	R1/4	0.433	3.028	0.839	1.437	1.354	0.492	0.571	0.492	0.571	0.713	0.669	0.551	0.181	1.446
ATBEW8-6-03- <input type="checkbox"/>	0.315	0.236	R3/8	0.472	3.177	0.839	1.571	1.354	0.492	0.571	0.492	0.709	0.713	0.669	0.669	0.181	1.834
ATBEW10-6-03- <input type="checkbox"/>	0.394	0.236	R3/8	0.472	3.209	0.878	1.504	1.457	0.492	0.689	0.492	0.709	0.795	0.669	0.669	0.181	1.975
ATBEW10-6-04- <input type="checkbox"/>	0.394	0.236	R1/2	0.591	3.366	0.878	1.587	1.457	0.492	0.689	0.492	0.787	0.795	0.669	0.827	0.181	2.751
ATBEW10-8-03- <input type="checkbox"/>	0.394	0.315	R3/8	0.472	3.457	0.933	1.634	1.575	0.492	0.689	0.571	0.709	0.795	0.713	0.669	0.264	2.293
ATBEW10-8-04- <input type="checkbox"/>	0.394	0.315	R1/2	0.591	3.617	0.933	1.717	1.575	0.492	0.689	0.571	0.787	0.795	0.713	0.827	0.264	3.069

* - ⇒ Select either blank (standard) or D (non-lubricant specification)

● **ATBZ**



(1 bag, 10 pcs.)

Tube size
0.157
0.236
0.315
0.394
0.472

Order codes

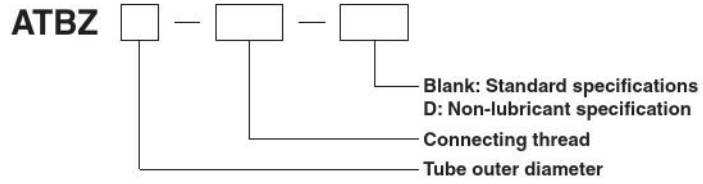

Dimensions in

**Branch tetra
ATBZ**

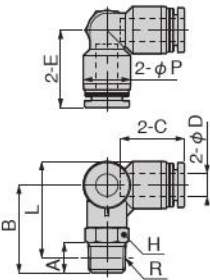

Metric thread type

Model	Tube outer diameter ϕD	R	A	B	L	ϕP	C	E	Width across flats Hex.	OOrifice diameter (ϕ in)	Mass oz
ATBZ4-M5- <input type="checkbox"/>	0.157	M5×0.8	0.110	0.799	0.886	0.394	0.587	0.717	0.394	0.094	0.353
ATBZ4-M6- <input type="checkbox"/>	0.157	M6×1	0.150	0.839	0.886	0.394	0.587	0.717	0.394	0.118	0.388
ATBZ4-01- <input type="checkbox"/>	0.157	R1/8	0.315	0.917	0.957	0.394	0.587	0.717	0.394	0.118	0.459
ATBZ4-02- <input type="checkbox"/>	0.157	R1/4	0.433	1.142	1.102	0.394	0.587	0.815	0.551	0.118	0.705
ATBZ6-M5- <input type="checkbox"/>	0.236	M5×0.8	0.110	0.799	0.933	0.492	0.669	0.807	0.394	0.094	0.423
ATBZ6-M6- <input type="checkbox"/>	0.236	M6×1	0.150	0.839	0.933	0.492	0.669	0.807	0.394	0.118	0.423
ATBZ6-01- <input type="checkbox"/>	0.236	R1/8	0.315	0.917	1.004	0.492	0.669	0.807	0.394	0.181	0.529
ATBZ6-02- <input type="checkbox"/>	0.236	R1/4	0.433	1.102	1.110	0.492	0.669	0.858	0.551	0.181	0.776
ATBZ6-03- <input type="checkbox"/>	0.236	R3/8	0.472	1.240	1.236	0.492	0.669	0.937	0.669	0.181	1.164
ATBZ8-01- <input type="checkbox"/>	0.315	R1/8	0.315	0.984	1.114	0.571	0.713	0.894	0.472	0.236	0.705
ATBZ8-02- <input type="checkbox"/>	0.315	R1/4	0.433	1.142	1.189	0.571	0.713	0.933	0.551	0.264	0.882
ATBZ8-03- <input type="checkbox"/>	0.315	R3/8	0.472	1.260	1.295	0.571	0.713	0.972	0.669	0.264	1.270
ATBZ10-02- <input type="checkbox"/>	0.394	R1/4	0.433	1.157	1.264	0.689	0.795	1.024	0.551	0.315	1.093
ATBZ10-03- <input type="checkbox"/>	0.394	R3/8	0.472	1.299	1.394	0.689	0.795	1.063	0.669	0.327	1.482
ATBZ10-04- <input type="checkbox"/>	0.394	R1/2	0.591	1.457	1.480	0.689	0.795	1.083	0.827	0.327	2.328
ATBZ12-02- <input type="checkbox"/>	0.472	R1/4	0.433	1.213	1.386	0.827	0.921	1.189	0.551	0.315	1.305
ATBZ12-03- <input type="checkbox"/>	0.472	R3/8	0.472	1.319	1.484	0.827	0.921	1.189	0.669	0.394	1.728
ATBZ12-04- <input type="checkbox"/>	0.472	R1/2	0.591	1.496	1.587	0.827	0.921	1.228	0.827	0.406	2.610

* - ⇒ Select either blank (standard) or D (non-lubricant specification)

● ASKR



Order codes

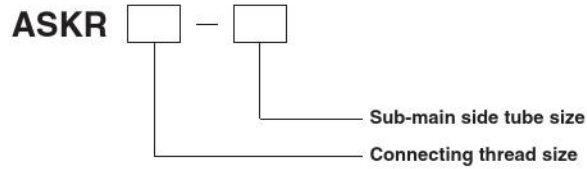

Main side thread size	Sub-main side tube size				
	0.157	0.236	0.315	0.394	0.472
M8×1 (8)	0.315-0.157	0.315-0.236	—	—	—
M12×1 (12)	—	0.472-0.236	0.472-0.315	0.472-0.394	—
M14×1 (14)	—	—	0.551-0.315	0.551-0.394	0.551-0.472
M18×1 (18)	—	—	—	—	0.709-0.472

Dimensions in

Reducer for bulkhead
ASKR

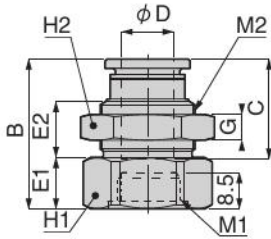

Model	Tube outer diameter ϕD	M1	M2	B	E1	E2	C	G	H1	H2	Effective area Cv	Mass oz
ASKR8-4	0.157	M8×1	M12×1	1.024	0.315	0.465	0.587	0.157	0.551	0.551	103.320	0.635
ASKR8-6	0.236	M8×1	M14×1	1.106	0.315	0.547	0.669	0.157	0.669	0.669	212.175	1.023
ASKR12-6	0.236	M12×1	M14×1	1.106	0.472	0.390	0.669	0.157	0.669	0.669	243.540	0.988
ASKR12-8	0.315	M12×1	M16×1	1.138	0.394	0.461	0.717	0.157	0.748	0.748	505.530	1.164
ASKR12-10	0.394	M12×1	M20×1	1.272	0.394	0.539	0.815	0.197	0.866	0.945	642.060	2.011
ASKR14-8	0.315	M14×1	M16×1	1.138	0.472	0.382	0.717	0.157	0.748	0.748	511.065	1.129
ASKR14-10	0.394	M14×1	M20×1	1.272	0.394	0.539	0.815	0.197	0.945	0.945	769.365	2.116
ASKR14-12	0.472	M14×1	M22×1	1.374	0.472	0.512	0.917	0.236	0.945	1.063	1009.215	2.610
ASKR18-12	0.472	M18×1	M22×1	1.374	0.472	0.512	0.917	0.236	1.063	1.063	1230.615	2.787