

ELECTRONIC PRESSURE SWITCHES

PS4 Series

Highly reliable and more responsive solid state type.
Achieves precision and advanced performance of $\pm 3\%$ F.S!
Three-directional mounting boosts design layout flexibility!

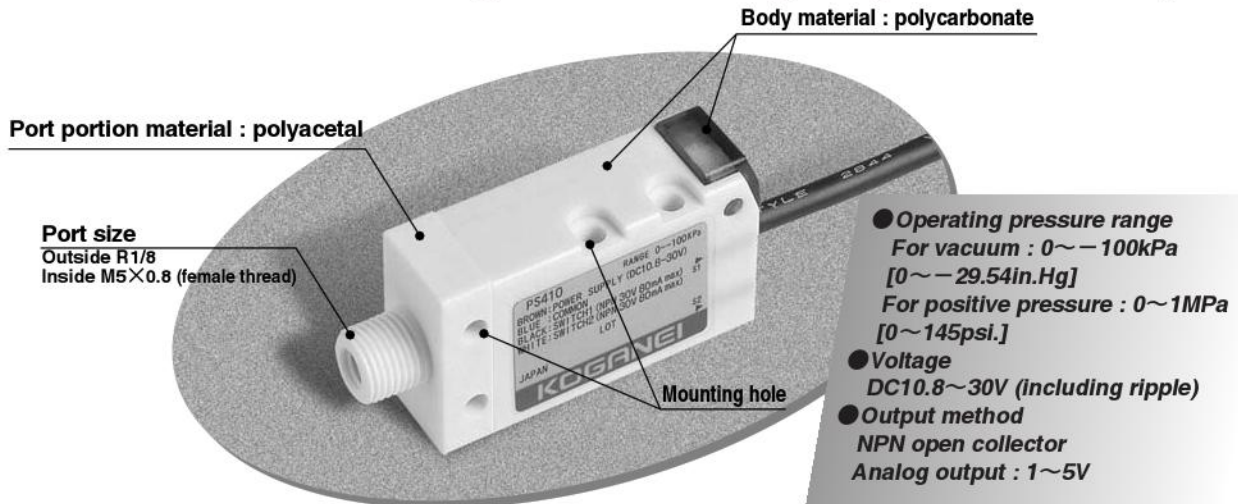

■ **Output specifications are of *TWO* types, for flexible use!**

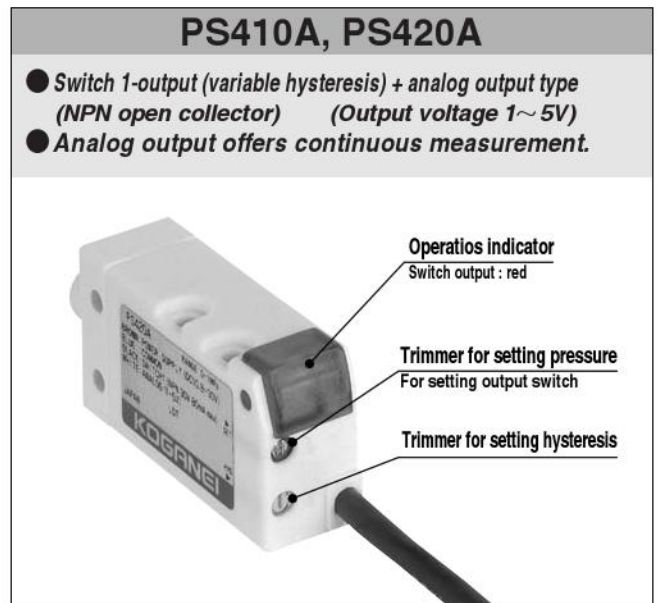
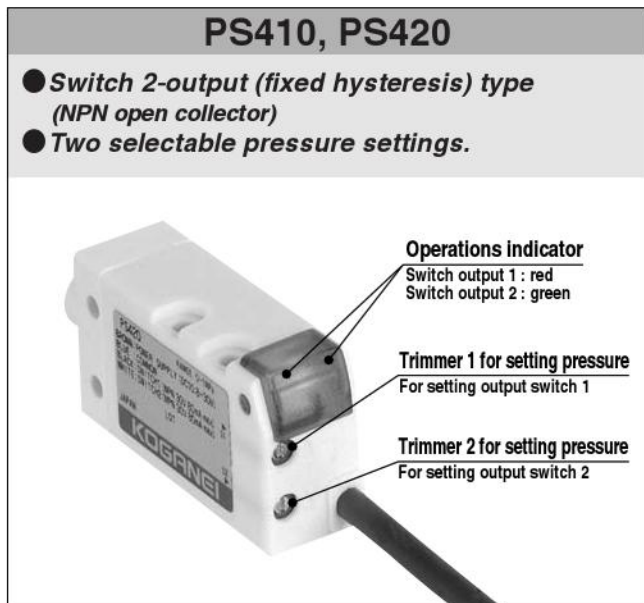

Order Codes

PS4

Electronic pressure switch

Operating pressure range
 10: For vacuum 0~-100kPa [0~-29.54in.Hg]
 20: For positive pressure 0~1MPa [0~145psi.]

Output specification
 Blank : Switch 2-output (fixed hysteresis)
 A : Switch 1-output (variable hysteresis) + analog output

Caution: Be aware that there are two types of switch output, fixed hysteresis and variable hysteresis.

Specifications

● Electronic pressure switches PS4 series

Item	Type Model	Vacuum	Positive pressure	Vacuum	Positive pressure
		Switch 2-output (fixed hysteresis)		Switch 1-output (variable hysteresis) + analog output	
		PS410	PS420	PS410A	PS420A
Pressure range		0~−100kPa [0~−29.54in.Hg]	0~1MPa [0~145psi.]	0~−100kPa [0~−29.54in.Hg]	0~1MPa [0~145psi.]
Rated pressure		−100kPa [−29.54in.Hg]	1MPa [145psi.]	−100kPa [−29.54in.Hg]	1MPa [145psi.]
Maximum pressure		200kPa [29.0psi.]	1.5MPa [218psi.]	200kPa [29.0psi.]	1.5MPa [218psi.]
Breaking pressure		500kPa [72.5psi.]	2.0MPa [290psi.]	500kPa [72.5psi.]	2.0MPa [290psi.]
Operating temperature		−20~70°C [−4~158°F]			
Compensation temperature		0~50°C [32~122°F]			
Storage temperature		−20~80°C [−4~176°F] (Humidity of 65% RH or less, atmospheric pressure)			
Operating ambient humidity		35~85% RH			
Applicable media		Air or non-corrosive gas			
Insulation resistance		100MΩ MIN. (at DC500V megger)			
Dielectric strength		AC500V, 1 minute			
Cable		Shielded 4-lead			
Mass		50g [1.76oz.]			
Power supply	Voltage	DC10.8~30V (including ripple)			
	Consumption current	25mA or less ^{Note 1}		17mA or less ^{Note 1}	
	Number of outputs	2		1	
	Output method	NPN open collector			
	Pressure setting method	Variable, with use of trimmer			
	Pressure setting range	0~100% of the rated pressure			
	Output display	When ON, operation indicator (LED) lights up.			
	Accuracy	±3% F.S. or less ^{Note 2}			
	Hysteresis	2% F.S. or less (fixed)		Variable by 1-15% of the set value (reference value)	
	Switch capacity	DC30V, 80mA MAX.			
	Residual voltage	0.8V or less (at inrush current 80mA)			
	Response speed	1ms (reference value)			
	Output voltage			1~5V	
	Zero-point voltage (V ^{ZERO})			1±0.1V	
	Span voltage (V ^{SPAN})			4±0.1V	
	Temperature characteristics V ^{ZERO}			±0.1% F.S./°C ^{Note 2}	
	Temperature characteristics V ^{SPAN}			±0.1% F.S./°C ^{Note 2}	
	Output current			1mA or less ^{Note 3}	
	Linearity/hysteresis			±0.5% F.S. MAX.	
Environmental characteristics	Vibration resistance	98.1m/s ² [10G]			
	Shock resistance	490m/s ² [50G] (Non-repeated shock)			
	Continuous operation	10 ⁸ times MIN. (0~rated pressure)			
	Humidity resistance	90~95% RH 240 hours (40°C [104°F])			

Notes: 1. With power voltage of DC24V when output is ON.

2. At 0~50°C [32~122°F]; reference point 25°C [77°F].

3. Load resistance of 5kΩ or more.

Remark: Unless otherwise specified, the defined condition is an ambient temperature of 25±5°C [77±9°F], and power voltage of DC12V.

Switch Operation

Switches to ON at the set pressure, and switches to OFF when the hysteresis value is reached.

● PS410 □

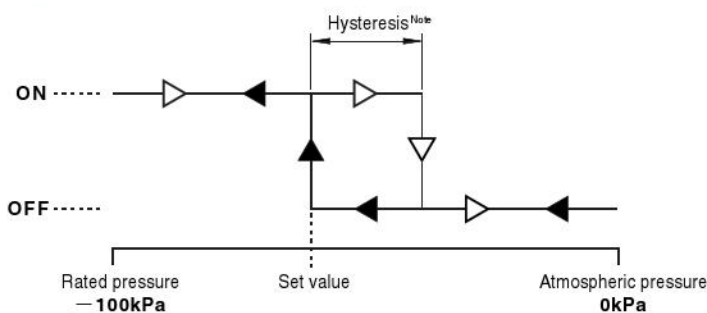

● PS420 □

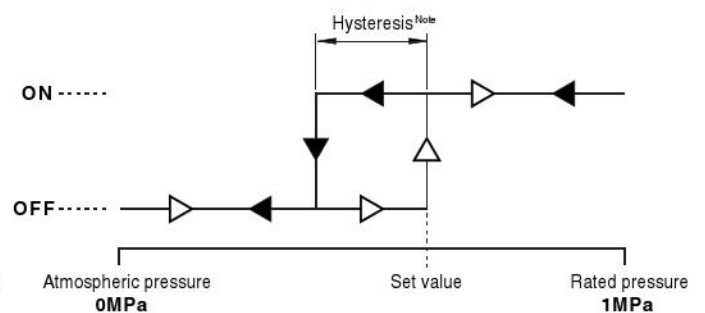

Note: The PS410 and PS420 types are fixed hysteresis (2% F.S. or less).

Dimensions (mm)

● PS410, PS420 Switch 2-output (fixed hysteresis) type

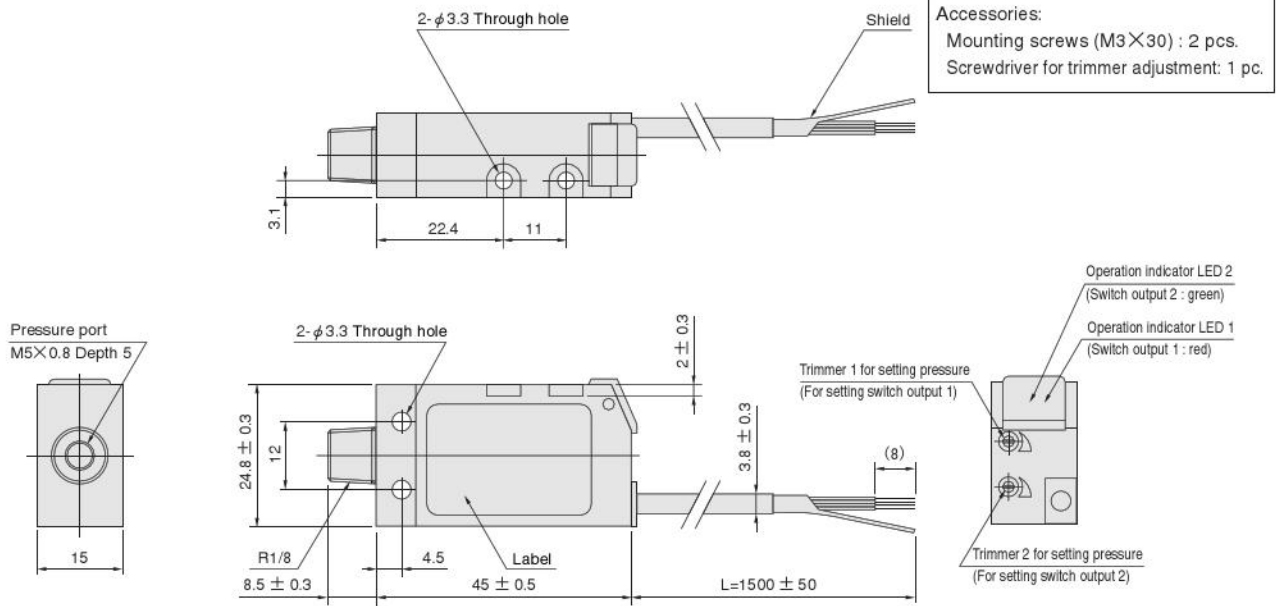

● PS410A, PS420A Switch 1-output (variable hysteresis) + analog output type

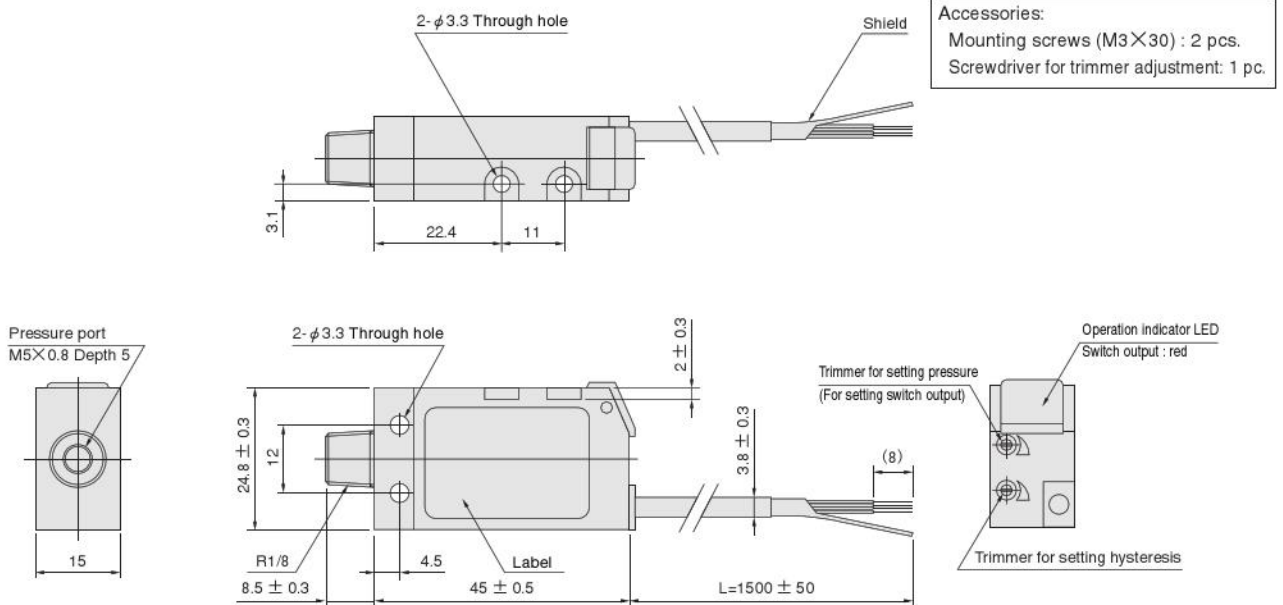

Internal Circuit

● PS410, PS420

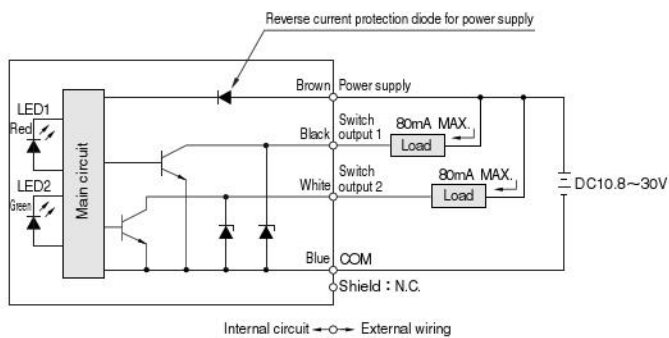

● PS410A, PS420A

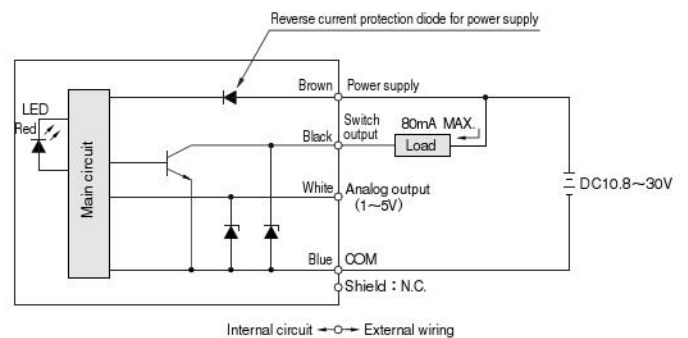



Mounting and piping

Piping

● When R1/8 male thread is used

Hold the body port portion to tighten, and do not exceed a tightening torque of $4.9\text{N}\cdot\text{m}$ [$3.6\text{ft}\cdot\text{lbf}$] to secure. If necessary, use sealing tape.

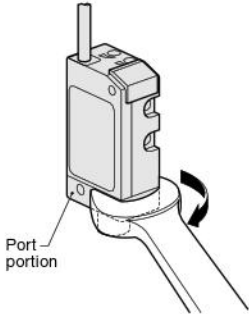

● When M5 female thread is used for attaching fitting

Hold the body port portion to tighten, and do not exceed a tightening torque of $0.49\text{N}\cdot\text{m}$ [$0.36\text{ft}\cdot\text{lbf}$] to secure.

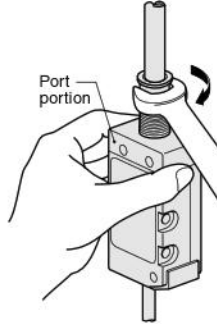

- Cautions:**
1. Tightening in excess of the specified tightening torque could result in damage to the pressure switch.
 2. The only area where the wrench may be applied is the port portion. Do not use the wrench on any other location.
 3. Always thoroughly blow off (use compressed air) or air blowing the tubing before piping. Be careful to prevent chips, sealing tape, or rust, etc., generated during piping work from entering into the pipes.

Mounting body

(1) Side mounting

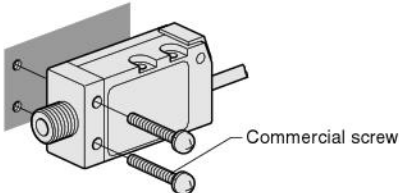

(2) Flat mounting

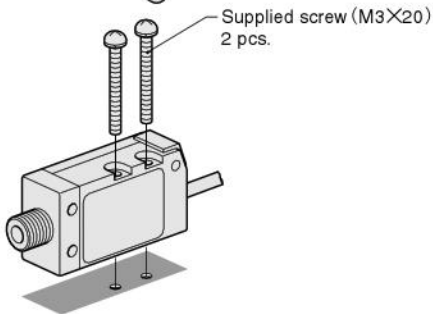

(3) Stacked mounting

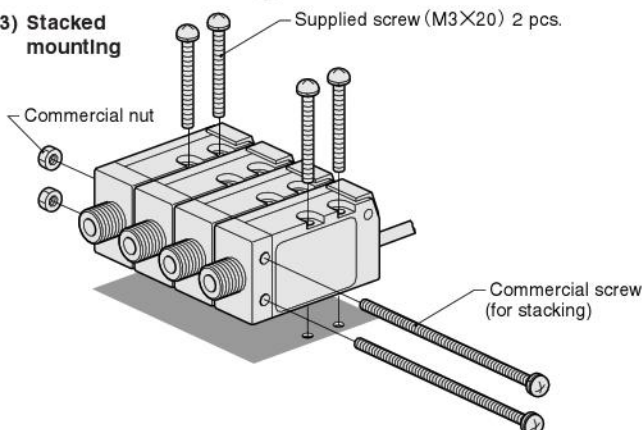

Setting

● PS410, PS420 Switch 2-output (fixed hysteresis) type

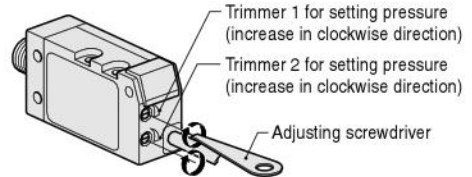

- 1) Apply pressure to activate switch 1, and then rotate the pressure setting trimmer 1 to set. (When switch output 1 is ON, the operation indicator (red) lights up.)
- 2) Apply pressure to activate switch 2, and then rotate the pressure setting trimmer 2 to set. (When switch output 2 is ON, the operation indicator (green) lights up.)

● PS410A, PS420A Switch 1-output (variable hysteresis) + analog output type

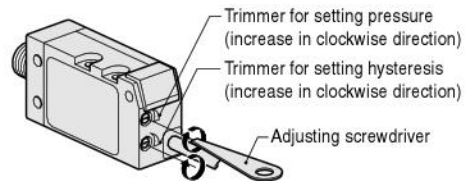

- 1) Use the Trimmer for setting hysteresis to set the hysteresis to an appropriate value.
- 2) Apply pressure to activate the switch, rotate the trimmer for setting pressure, and set.
- 3) Repeat steps 1) and 2) above to determine the setting points.

- Cautions:**
1. When using the trimmer for setting, be careful to avoid applying excessive force.
 2. The rotation torque for the trimmer for setting hysteresis should not exceed $4.4\text{N}\cdot\text{cm}$ [$0.39\text{in}\cdot\text{lbf}$].
 3. If the pressure setting trimmer is rotated too far, clicking sounds warn that it is beyond the normal adjustment range. Return the pressure setting trimmer to within the adjustment range in the case.

Handling Instructions and Precautions

Wiring instructions

Basic connection

●PS410, PS420 Switch 2-output (fixed hysteresis) type

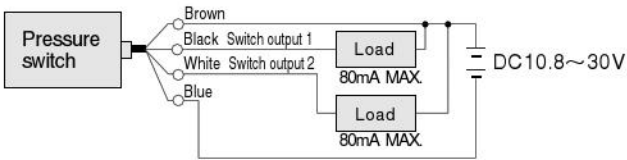

●PS410A, PS420A Switch 1-output (variable hysteresis) + analog output type

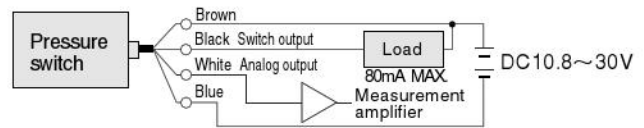

Connection to programmable controller

●PS410, PS420 Switch 2-output (fixed hysteresis) type

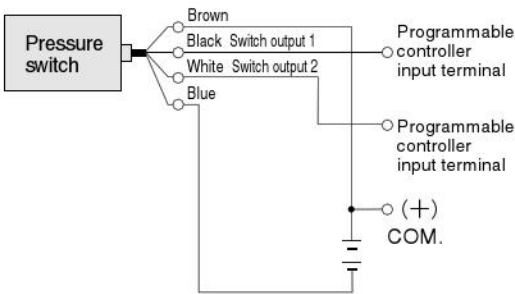

●PS410A, PS420A Switch 1-output (variable hysteresis) + analog output type

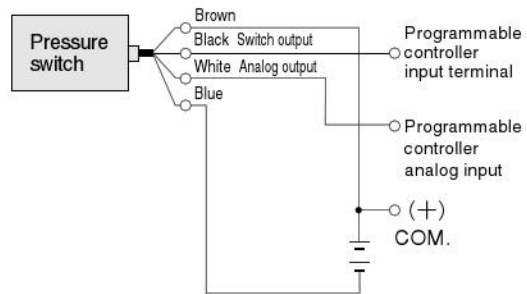

- Cautions:**
1. For the power supply, use a stable direct current power supply. If using a power supply unit such as a switching power supply, use it with the FG terminal grounded.
 2. Pay attention to the color of the lead wire to connect. Miswiring could cause incorrect operation or damage.
 3. Do not short-circuit the switch output terminal with any other terminal, nor connect to a low-resistance load with a current exceeding 80mA. Such actions will damage the internal circuits.
 4. Use a surge protection diode, etc., for relays and other inductive loads.



General precautions

1. This product does not feature a drip-proof or dust-proof construction. Do not use in locations subject to dripping water, dripping oil, or dust, etc., or in corrosive atmospheres.
2. Do not use corrosive gases or fluids in the medium.
3. Do not apply pressure in excess of the maximum pressure value.
4. Do not subject the lead wires to strong pulling force or excessive bending. In addition, when handling the product, always hold it by the body and avoid applying excessive force to the power cord.
5. As subjecting the pressure switch to strong shocks could lead to damage or erratic operation, be careful when handling it.