

HOLDERS AND COLUMN TUBES

alpha series



Holder and Column Tubes are:

- Highly reliable fixtures in firm support of actuator operations.
- High quality support equipment with flexible adaptability to all design and assembly requirements in mechanical devices.
- Column Tubes come in three types and nine variations capable of heavy-load operations.

Order Codes

● Column tube

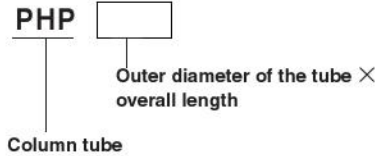

■ Outer diameter of the tube and overall length

		mm	
Outer diameter of the tube	Overall length		
40 [1.575in.]	300, 450, 600		
54 [2.126in.]	450, 600, 750		
74 [2.913in.]	600, 750, 900		

● Holder

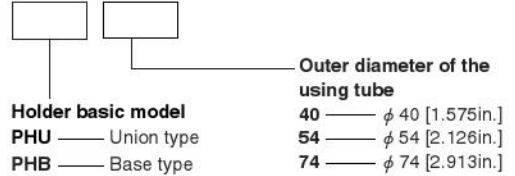

Dimensions (mm)

Column tube Materials: Mild steel (nickel plated)

● PHP



Code	A					B					C	D	E	F
	Overall length	300	450	600	750	900	300	450	600	750				
PHP40	300	450	600	—	—	Fully machined ^{※1}	Fully machined ^{※1}	300	—	—	70	ϕ 42.7	ϕ 40h8 _{Δ0.030}	ϕ 32.7
PHP54	—	450	600	750	—	—	Fully machined ^{※2}	300	300	—	80	ϕ 57	ϕ 54h8 _{Δ0.046}	ϕ 43
PHP74	—	—	600	750	900	—	—	300	300	300	120	ϕ 76.3	ϕ 74h8 _{Δ0.046}	ϕ 62.3

■ Mass

Type	Overall length mm	g [oz.]				
		300	450	600	750	900
PHP40	900 [31.7]	1480 [52.2]	2290 [80.8]	—	—	
PHP54	—	2970 [104.8]	4410 [155.6]	5700 [201.1]	—	
PHP74	—	—	6300 [222.2]	8090 [285.4]	9900 [349.2]	

Holder Materials: aluminum alloy casting (black painted)

● PHU (Union type)

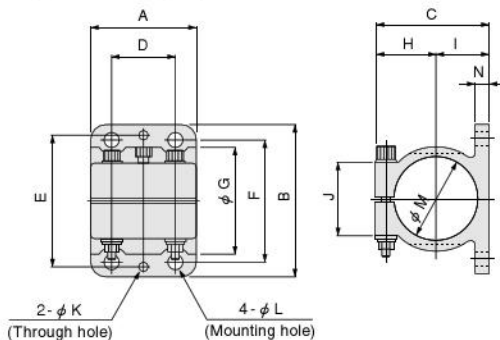

● PHB (Base type)

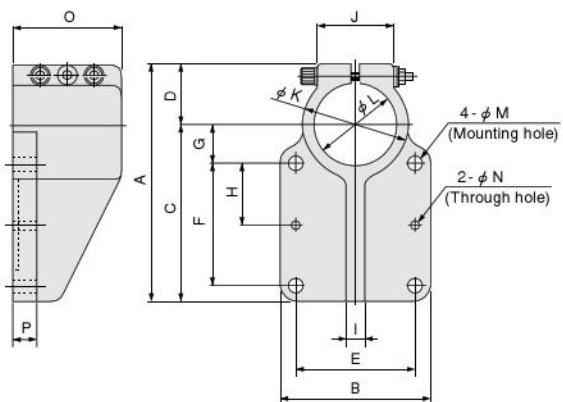

■ Mass g [oz.]

Model	Mass
PHU40	320 [11.3]
PHU54	510 [18.0]
PHU74	1170 [41.3]

■ Mass g [oz.]

Model	Mass
PHB40	440 [15.5]
PHB54	850 [30.0]
PHB74	2280 [80.4]

Code	A	B	C	D	E	F	G	H	I	J	K	L	M	N
PHU40	60	80	62	40	68	60	54	32	30	40	4	7	40H8 ^{+0.046} ₀	8
PHU54	70	100	75	40	86	80	70	40	35	50	5	9	54H8 ^{+0.046} ₀	10
PHU74	90	140	100	60	120	110	94	53	47	70	6	11	74H8 ^{+0.015} ₀	12

Code	A	B	C	D	E	F	G	H	I	J	K	L	M	N	O	P
PHB40	112	80	80	32	60	50	20	25	10	40	54	40H8 ^{+0.030} ₀	7	4	60	12
PHB54	155	100	115	40	80	80	25	40	12	50	70	54H8 ^{+0.046} ₀	9	5	70	15
PHB74	203	140	150	53	110	105	30	55	20	70	94	74H8 ^{+0.046} ₀	11	6	110	20