



## pulse blow unit PAU-50 Series



### Specifications

Model		PAU-50-04(-25)	PAU-50-06(-25)
Item			
Medium		Air	
Operating pressure range	MPa [psi]	0.35 to 0.7 [51 to 102]	
Pulse frequency	Hz	5 ~ 15 <sup>Note1</sup>	
Operating temperature range	°C [°F]	5 to 50 [41 to 122]	
Mass	g [oz]	289 (308) [10.2 (10.9)]	295 (319) [10.4 (11.3)]
Material		Aluminum alloy	
Port size	IN port	Rc1/2	Rc3/4
	OUT port		

Note 1 : Specifications may not be met depending on piping conditions and used nozzles.  
 2 : Air that is used should be clean air that contains no oil, solids, or other contaminants. If drainage water, dust, and other contaminants get into the pulse blow unit, they could cause defective operation.  
 3 : This product uses grease internally.

### Order codes

#### ● Main unit

**PAU-50-**  -

#### Mounting option

**Blank** : Mounting screw hole only  
**25** : Direct mounting

#### Port size

**04** : Rc1/2 (for both IN and OUT)  
**06** : Rc3/4 (for both IN and OUT)

### Dimensions (mm [in.])

#### ● Main unit PAU-50-04

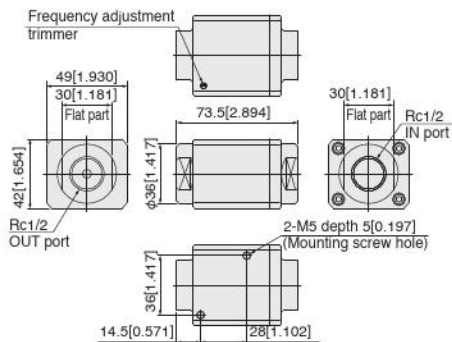

#### PAU-50-04-25

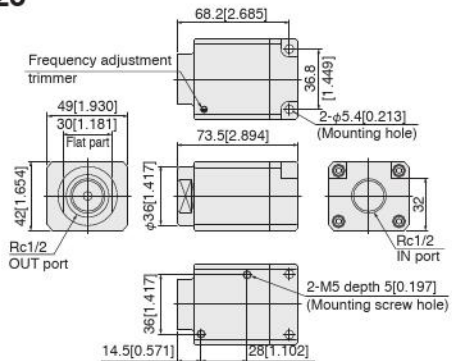

#### PAU-50-06

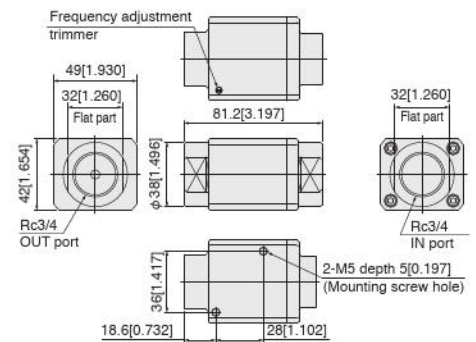

#### PAU-50-06-25

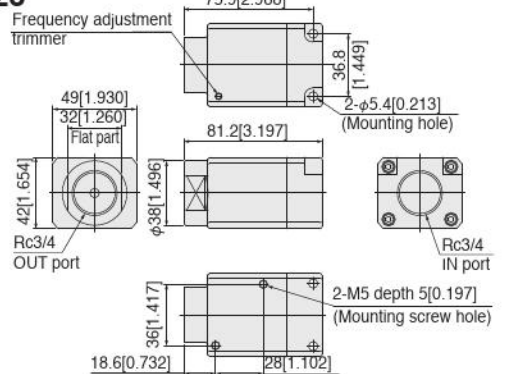

### Frequency adjustment method

The pulse frequency can be adjusted by rotating the frequency adjustment trimmer, as shown in the figure at right. Use a precision flat blade screwdriver for adjustments.

Turn it in the + direction (counterclockwise direction) to increase the frequency.  
 Turn it in the - direction (clockwise direction) to decrease the frequency.

Note: Turning the trimmer counterclockwise increases the frequency and turning it clockwise decreases the frequency. Turning the trimmer more than necessary after turning it fully clockwise or counterclockwise may damage the components.

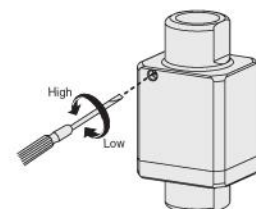

# Characteristics of the frequency and flow according to the number of rotations of the trimmer

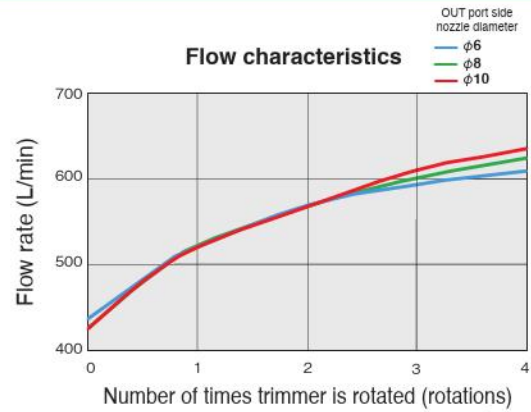
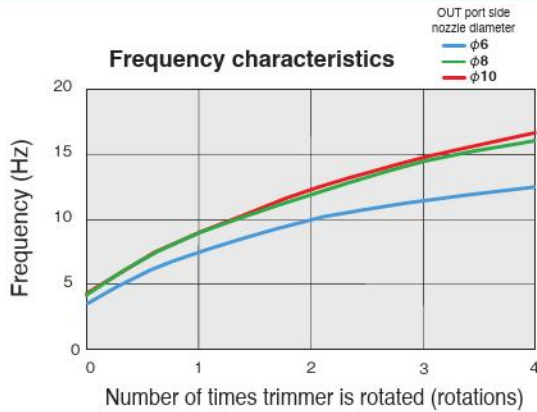

- Note 1: According to our test conditions ①.
- 2: The characteristics of the frequency and the flow vary depending on the piping conditions and the nozzle used.
- 3: Use devices within the pulse frequency ranges (5 to 15 Hz) shown in the specification tables.

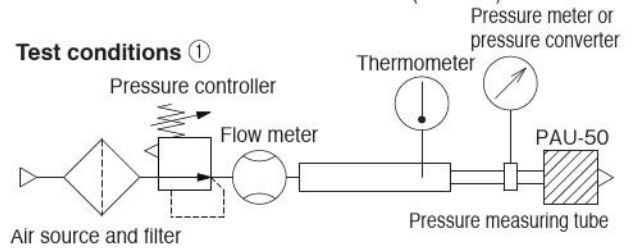

## Operations according to piping conditions for pulse blow units

Operations may be unstable, depending on the piping conditions on the IN port side. See the following table.

Nozzle diameter	Operating pressure	Tube φ 10 [0.394]		Tube φ 12 [0.472]	
		1000 mm [39.370 in.]	5000 mm [196.9 in.]	1000 mm [39.370 in.]	5000 mm [196.9 in.]
φ 6 [0.236]	0.35 MPa [51 psi]	×	×	○	×
	0.5 MPa [73 psi]	○	○	○	○
	0.7 MPa [102 psi]	○	○	○	○
φ 8 [0.315]	0.35 MPa [51 psi]	×	×	○	×
	0.5 MPa [73 psi]	×	×	○	○
	0.7 MPa [102 psi]	○	△	○	○
φ 10 [0.394]	0.35 MPa [51 psi]	×	×	○	×
	0.5 MPa [73 psi]	×	×	○	○
	0.7 MPa [102 psi]	○	○	○	○

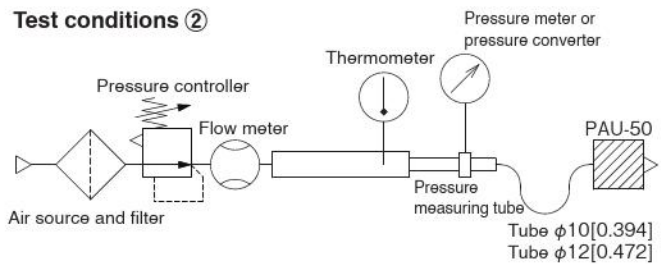

- Note 1: ○ : Stable operations x: Unstable operations (according to our test conditions ②)
- 2: Operations will be unstable if the piping conditions cause pressure drops or insufficient flow.

## Handling precautions

### Warning

- Use safety glasses and earplugs because blowing air could blow objects into people's eyes or cause hearing loss.
- Install a cutoff valve on the IN port side to ensure safety in case of leaks or damage.

### Caution

- Air containing oil or solids cannot be used. Use cleaned air for the medium (use a filter that has a filtration rating of 40 μm or less). If drainage water, dust, and other contaminants get into this product, they could cause defective operation.
- Pass the medium through a device, such as a freeze-type air dryer or after cooler, to lower the dew-point temperature of the medium to below the ambient temperature so condensation or frost does not occur when the products are blowing.
- Use this product within the pulse frequency ranges shown in the specification tables.

- This product operates on a balance of pressure, so supply enough pressure and volume to keep the pulse operation steady.
- It is recommended to make a one-to-one connection between this product and the air blow gun or a nozzle.
- If you want to install this product apart from the air blow gun or nozzle, a φ 10 [0.394]x6.5 tube and a distance not exceeding 2 m [6.560 ft] are recommended.
- When piping to the IN or OUT port, tighten within the following torque range.

Recommended tightening torque N·m [in·lbf]	PAU-50-04(-25)	PAU-50-06(-25)
	20 to 22 [177.02 to 194.72]	28 ~ 30 [247.83 to 265.53]

- Leaving the unit in a dusty environment may allow dust to enter inside, which may cause malfunction.
- When using a tube, the tube should be free of scratches on the outside surface. Also, do not bend or pry the tube excessively. Doing so could cause air leakage.
- Do not mount this product on the secondary side of an electrostatic eliminator. Doing so will reduce the neutralization function of air blowing considerably.

**Caution** \* Read "Safety precautions" on the general catalog website before using this product.