

Slit Type Rodless Cylinders ORCA, ORGA

A bend-resistant and wear-resistant stainless chrome steel seal band is used, which enables high performance and long life.



ORCA <Basic type>

1. Space-saving design

Almost the total length of the cylinder body is equal to a cylinder stroke, and the installation space is 1/2 of conventional cylinders. Also, multiple piping ports are arranged. This port arrangement allows versatile plumbing applications including one side piping.

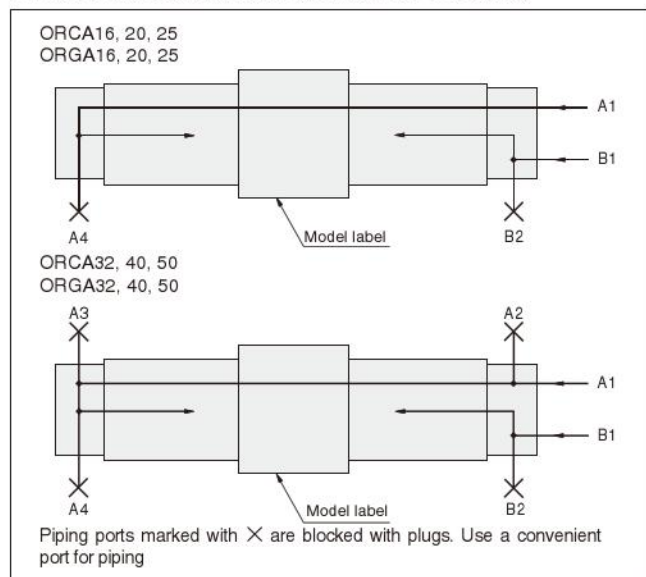

2. High-speed operation

High-speed operation of 3000mm/s [118in./sec.] is also possible. (ORCA16, 20 and ORGA have maximum speeds of 1500mm/s [59in./sec.])

3. Various options

Various piston mounts and mounting brackets, many types of easily mounted small sensor switches, and fluoro rubber specification are available.

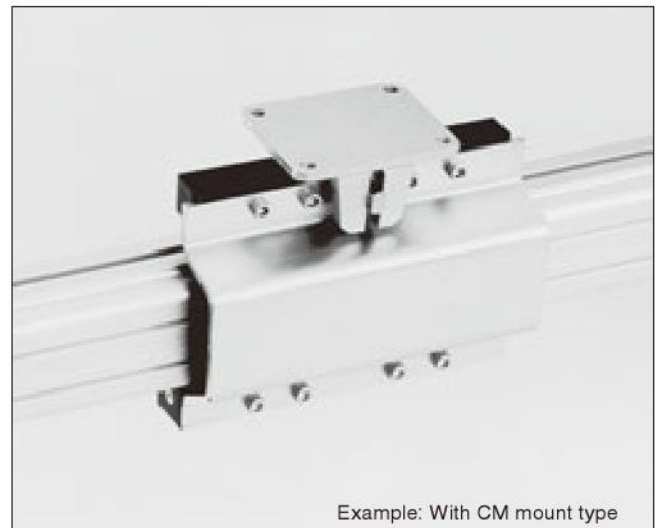

Example: With CM mount type



Wide range of products strongly supports space-saving and simplicity in design.
Bore size: $\phi 16$ [0.630in.], $\phi 20$ [0.787in.], $\phi 25$ [0.984in.],
 $\phi 32$ [1.260in.], $\phi 40$ [1.575in.], and $\phi 50$ [1.969in.]

SLIT TYPE RODLESS CYLINDERS ORCA, ORGA SERIES

ORGA <With guide>

1. Installed with a guide for greater accuracy and durability.

The guide mechanism is composed of a slider and cylinder body. The high rigid body enables a heavy load and highly accurate operation.

Maximum load capacity:

784.5N [176lbf.] ($\phi 50$ [1.969in.])

Maximum bending moment:

112.8N·m [83.2ft·lbf] ($\phi 50$ [1.969in.])

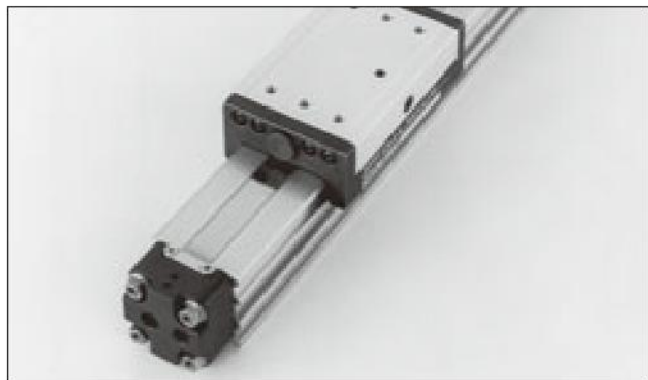

2. The variety of options enables stroke adjustment and high-speed operation.

It is possible to select as an option either a stroke adjusting bolt which enables fine adjustment of the position at the end of the stroke, or a shock absorber that will absorb the impact of shocks at the end of the stroke under high speed operation. It ensures high-speed operation and highly accurate stops.

ORGA

With Guide



Symbol

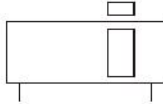

Specifications

Bore size mm [in.]		16 [0.630]	20 [0.787]	25 [0.984]	32 [1.260]	40 [1.575]	50 [1.969]
Media		Air					
Operation type		Double acting type					
Operating pressure range MPa [psi.]		0.15~0.8 [22~116]					
Proof pressure MPa [psi.]		1.2 [174]					
Operating temperature range °C [°F]		0~60 [32~140]					
Operating speed range mm/s [in./sec.]		100~1000 [3.9~39.4]					
Cushion	Standard specification	Variable cushion					
	Cushioning stroke (one side) mm [in.]	15 [0.591]	18 [0.709]	21 [0.827]	26 [1.024]	40 [1.575]	
	Option	With shock absorber					
Lubrication		Not required ^{Note 1}					
Stroke adjusting range ^{Note 2} (One side to the specification stroke) mm [in.]	With shock absorber (optional)	Up to the full stroke and fine adjustment 0~15 [0~-0.591]	Up to the full stroke and fine adjustment 0~20 [0~-0.787]	Up to the full stroke and fine adjustment 0~30 [0~-1.181]			
	Stroke adjusting bolt (optional)	0~4 [0~-0.157] (Fine adjustment only at the stroke end)	0~5 [0~-0.197] (Fine adjustment only at the stroke end)	0~6 [0~-0.236] (Fine adjustment only at the stroke end)	0~8 [0~-0.315] (Fine adjustment only at the stroke end)	0~10 [0~-0.394] (Fine adjustment only at the stroke end)	
Stroke tolerance mm [in.]	1000 [39.37] or less	+1.5 [+0.059] 0 [0]					
	1001~3000 [39.41~118.11]	+2.0 [+0.079] 0 [0]					
	3001~5000 [118.15~196.85]	+2.5 [+0.098] 0 [0]					
Port size		M5×0.8	Rc1/8		Rc1/4		Rc3/8

Notes: 1. These models can be used without lubrication, if lubrication is required, use Turbine Oil Class 1 (ISO VG32) or equivalent.

2. For details, see p.1099.

Remark: For details of sensor switches, see p.1544.

Specifications of Shock Absorber

Item	Model	KSHJ10×10-01	KSHJ12×10-01	KSHJ14×12-01	KSHJ18×16-01	KSHJ20×16-01	KSHJ22×25-01
Applicable cylinder		ORGA16	ORGA20	ORGA25	ORGA32	ORGA40	ORGA50
Maximum absorption J [ft.lbf]		3 [2.2]	6 [4.4]	10 [7.4]	20 [14.8]	30 [22.1]	50 [36.9]
Absorbing stroke mm [in.]		10 [0.394]		12 [0.472]	16 [0.630]		25 [0.984]
Maximum impact speed mm/s [in./sec.]		1000 [39.4]					
Maximum operating frequency cycle/min		60		40		30	
Maximum absorption per minute J/min [ft.lbf/min.]		120 [88.5]	220 [162]	240 [177]	320 [236]	450 [332]	500 [369]
Spring return force ^{Note} N [lbf.]		8.0 [1.80]	7.6 [1.71]	9.2 [2.07]	22.0 [4.95]	22.0 [4.95]	28.5 [6.41]
Angle variation		1° or less				3° or less	
Operating temperature range °C [°F]		0~60 [32~140]					

Note: Values at retracted position.

Caution: The life of the shock absorber may vary from the Slit Type Rodless Cylinder, depending on its operating conditions.

SLIT TYPE RODLESS CYLINDERS ORCA, ORGA SERIES

Cylinder Thrust

		N [lbf.]							
Bore size mm [in.]	Pressure area mm ² [in. ²]	Air pressure MPa [psi.]							
		0.15 [22]	0.2 [29]	0.3 [44]	0.4 [58]	0.5 [73]	0.6 [87]	0.7 [102]	0.8 [116]
16 [0.630]	200 [0.310]	30 [6.7]	40 [9.0]	60 [13.5]	80 [18.0]	100 [22.5]	120 [27.0]	140 [31.5]	160 [36.0]
20 [0.787]	314 [0.487]	47 [10.6]	63 [14.2]	94 [21.1]	126 [28.3]	157 [35.3]	188 [42.3]	220 [49.5]	251 [56.4]
25 [0.984]	490 [0.760]	49 [11.0]	98 [22.0]	147 [33.0]	196 [44.1]	245 [55.1]	294 [66.1]	343 [77.1]	392 [88.1]
32 [1.260]	804 [1.246]	80 [18.0]	161 [36.2]	241 [54.2]	322 [72.4]	402 [90.4]	482 [108.4]	563 [126.6]	643 [144.5]
40 [1.575]	1256 [1.947]	126 [28.3]	251 [56.4]	377 [84.7]	502 [112.8]	628 [141.2]	754 [169.5]	879 [197.6]	1005 [225.9]
50 [1.969]	1963 [3.043]	196 [44.1]	393 [88.3]	589 [132.4]	785 [176.5]	982 [220.8]	1178 [264.8]	1374 [308.9]	1570 [352.9]

Bore Size and Stroke

			mm
Bore size	Standard strokes	Available strokes	
16	100, 200, 300, 400, 500, 600, 700, 800	0~3000	
20	200, 300, 400, 500, 600, 700, 800, 1000, 1200, 1400, 1600, 2000	0~5000	
25	200, 300, 400, 500, 600, 700, 800, 1000, 1200, 1400, 1600, 2000		
32	200, 300, 400, 500, 600, 700, 800, 1000, 1100, 1200, 1400, 1600, 2000		
40	300, 400, 500, 600, 700, 800, 900, 1000, 1100, 1200, 1400, 1600, 1800, 2000		
50	300, 400, 500, 600, 700, 800, 900, 1000, 1100, 1200, 1400, 1600, 1800, 2000		

Remark: Non-standard strokes are available at 1mm pitch intervals. For delivery, consult us.

Mass

							kg [lb.]
Bore size mm [in.]	Zero stroke mass	Additional mass of each 1mm [0.0394in.] stroke	Additional mass of option				Additional mass of 1 sensor switch (with sensor holder)
			Shock absorber (with holder)	Stroke adjusting bolt (with holder)	L-type bracket	F-type support	
16 [0.630]	0.37 [0.82]	0.0013 [0.0029]	0.042 [0.093]	0.034 [0.075]	0.014 [0.031]	0.008 [0.018]	A : 0.05 [0.11] B : 0.09 [0.20]
20 [0.787]	0.71 [1.57]	0.0022 [0.0049]	0.07 [0.15]	0.056 [0.123]	0.03 [0.07]	0.015 [0.033]	
25 [0.984]	1.15 [2.54]	0.0027 [0.0060]	0.12 [0.26]	0.10 [0.22]	0.05 [0.11]	0.06 [0.13]	
32 [1.260]	2.45 [5.40]	0.0045 [0.0099]	0.22 [0.49]	0.17 [0.37]	0.10 [0.22]	0.08 [0.18]	
40 [1.575]	3.75 [8.27]	0.0054 [0.0119]	0.40 [0.88]	0.35 [0.77]	0.08 [0.18]	0.12 [0.26]	
50 [1.969]	5.80 [12.79]	0.0083 [0.0183]	0.62 [1.37]	0.52 [1.15]	0.22 [0.49]	0.12 [0.26]	

Inner Construction

ORGA16, 20, 25

Diagrams show ORGA20.

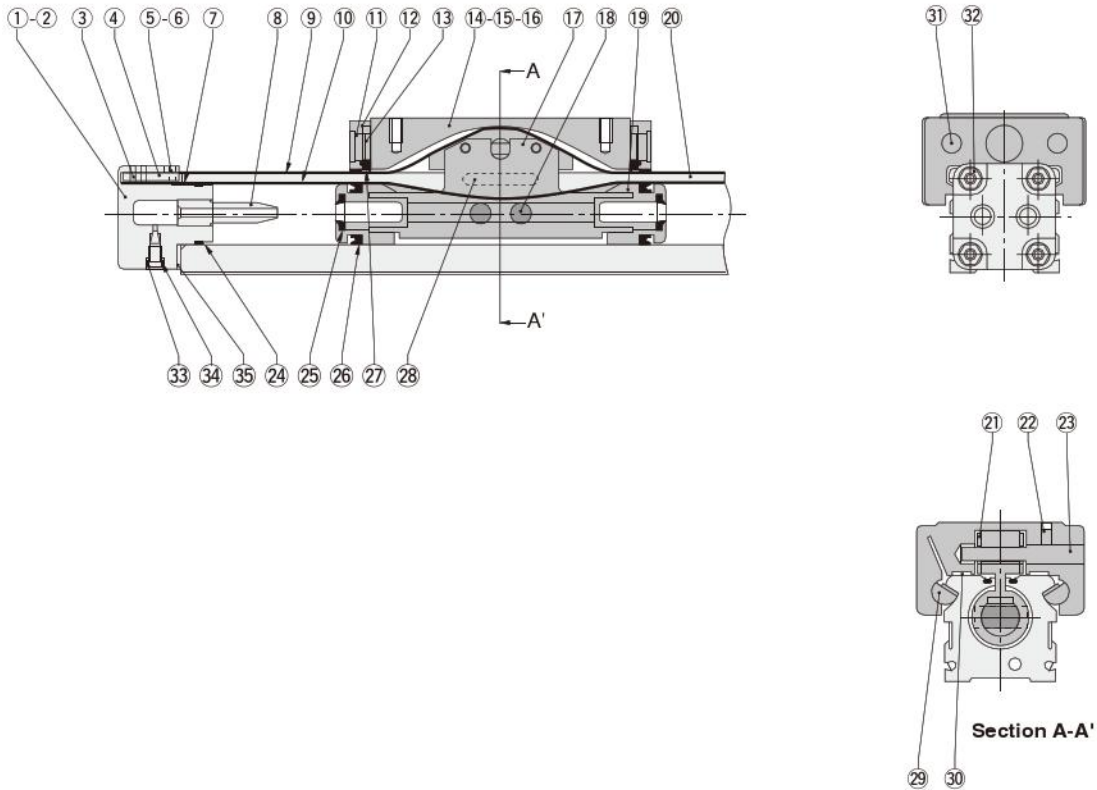

Major Parts and Materials

No.	Parts	Materials	Q'ty	Remark
①	End cap R ^{Note1}	Aluminum alloy	1	Anodized
②	End cap L ^{Note2}	Aluminum alloy	1	Anodized
③	Inner seal band setscrew	Alloy steel	4	Hexagon socket setscrew
④	Inner seal band lock	Steel	2	Nickel plated
⑤	Outer seal band lock	Steel	2	Nickel plated
⑥	Outer seal band setscrew	Steel	4	Cross recessed countersunk head screw
⑦	Rivet	Polyacetal	2	
⑧	Cushion pipe	Polyacetal	2	
⑨	Outer seal band	Stainless chrome steel	1	
⑩	Inner seal band	Stainless chrome steel	1	
⑪	Striker	Steel	2	
⑫	End plate	Aluminum alloy	2	Anodized
⑬	Scraper holder	Polyacetal	2	
⑭	Slider	Aluminum alloy	1	Anodized
⑮	Slider adjusting bolt	Alloy steel	4	Hexagon socket button head screw
⑯	Slider fixing setscrew	Alloy steel	4	Hexagon socket setscrew
⑰	Piston yoke	Aluminum alloy	1	Anodized

★: Available as a seal repair kit.

Notes: 1. The side where concentrated piping cannot be done.
2. The side where concentrated piping can be done.

No.	Parts	Materials	Q'ty	Remark
⑱	Magnet	Alnico magnet	2	
⑲	Piston	Polyacetal	2	
⑳	Cylinder barrel	Aluminum alloy	1	Anodized
㉑	Yoke mount	Steel	1	
㉒	Carrier pin setscrew	Alloy steel	1	Hexagon socket setscrew
㉓	Carrier pin	Alloy steel	1	Black oxide
㉔★	Cap gasket	Synthetic rubber (NBR)	2	
㉕★	Cushion seal	Synthetic rubber (NBR)	2	
㉖★	Piston seal	Synthetic rubber (NBR)	2	
㉗★	Scraper	Synthetic rubber (NBR)	2	
㉘★	Bearing strip	Polyethylene	2	
㉙	Guide shaft	Zinc alloy	2	φ25 [0.984in.] is polyacetal.
㉚	Guide plate	PTFE layer with filling material	4	
㉛	End plate mounting bolt	Alloy steel	4	
㉜	End cap screw	Alloy steel	8	Zinc plated
㉝★	Cushion gasket	Synthetic rubber (NBR)	2	
㉞	Cushion needle	Brass	2	
㉟★	Cylinder gasket	Aluminum alloy sheet	2	Synthetic rubber (NBR) baked

Inner Construction

ORGA32, 40, 50

Diagrams show ORGA40.

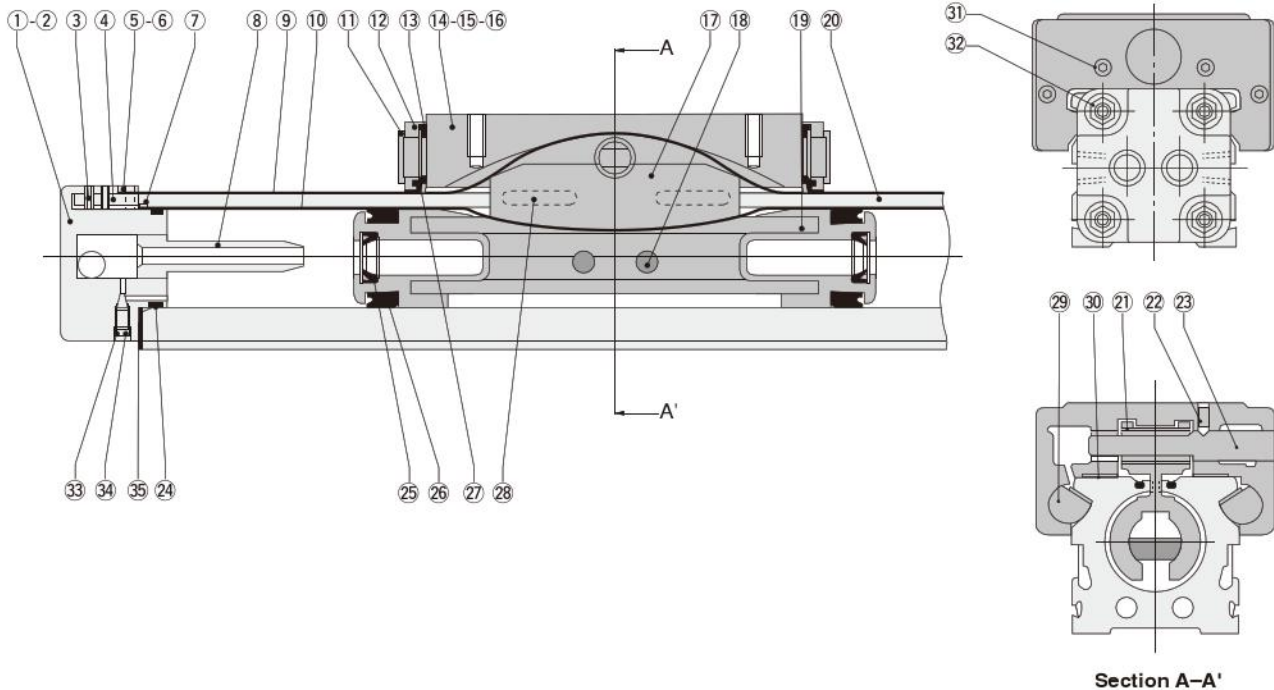

SLIT TYPE RODLESS CYLINDERS ORCA, ORGA SERIES

Major Parts and Materials

No.	Parts	Materials	Q'ty	Remarks
①	End cap R ^{Note1}	Aluminum alloy	1	Anodized
②	End cap L ^{Note2}	Aluminum alloy	1	Anodized
③	Inner seal band setscrew	Alloy steel	4	Hexagon socket setscrew
④	Inner seal band lock	Steel	2	Nickel plated
⑤	Outer seal band lock	Steel	2	Nickel plated
⑥	Outer seal band setscrew	Steel	4	Cross recessed countersunk head screw
⑦	Rivet	Polyacetal	2	
⑧	Cushion pipe	Polyacetal	2	
⑨	Outer seal band	Stainless chrome steel	1	
⑩	Inner seal band	Stainless chrome steel	1	
⑪	Striker	Steel	2	
⑫	End plate	Aluminum alloy	2	Anodized
⑬	Scraper holder	Polyacetal	2	
⑭	Slider	Aluminum alloy	1	Anodized
⑮	Slider adjusting bolt	Alloy steel	4	Hexagon socket button head screw
⑯	Slider fixing screw	Alloy steel	4	Hexagon socket setscrew
⑰	Piston yoke	Aluminum alloy	1	Anodized

★: Available as a seal repair kit.

Notes: 1. The side where concentrated piping cannot be done.
2. The side where concentrated piping can be done.

No.	Parts	Materials	Q'ty	Remarks
⑱	Magnet	Alnico magnet	2	
⑲	Piston	Polyacetal	2	
⑳	Cylinder barrel	Aluminum alloy	1	Anodized
㉑	Yoke mount	Steel	1	
㉒	Carrier pin setscrew	Alloy steel	1	Hexagon socket button head screw
㉓	Carrier pin	Alloy steel	1	Black oxide
㉔★	Cap gasket	Synthetic rubber (NBR)	2	
㉕★	Cushion seal	Synthetic rubber (NBR)	2	
㉖★	Piston seal	Synthetic rubber (NBR)	2	
㉗★	Scraper	Synthetic rubber (NBR)	2	
㉘★	Bearing strip	Polyethylene	4	
㉙	Guide shaft	Aluminum alloy	2	Anodized; Polyacetal for ORGA40 only
㉚	Guide plate	PTFE layer with filling material	4	
㉛	End plate mounting bolt	Alloy steel	8	
㉜	End cap screw	Alloy steel	8	Zinc plated
㉝★	Cushion gasket	Synthetic rubber (NBR)	2	
㉞	Cushion needle	Brass	2	
㉟★	Cylinder gasket	Aluminum alloy sheet	2	Synthetic rubber (NBR) baked

Dimensions of ORGA (mm)

ORGA Bore size × Stroke

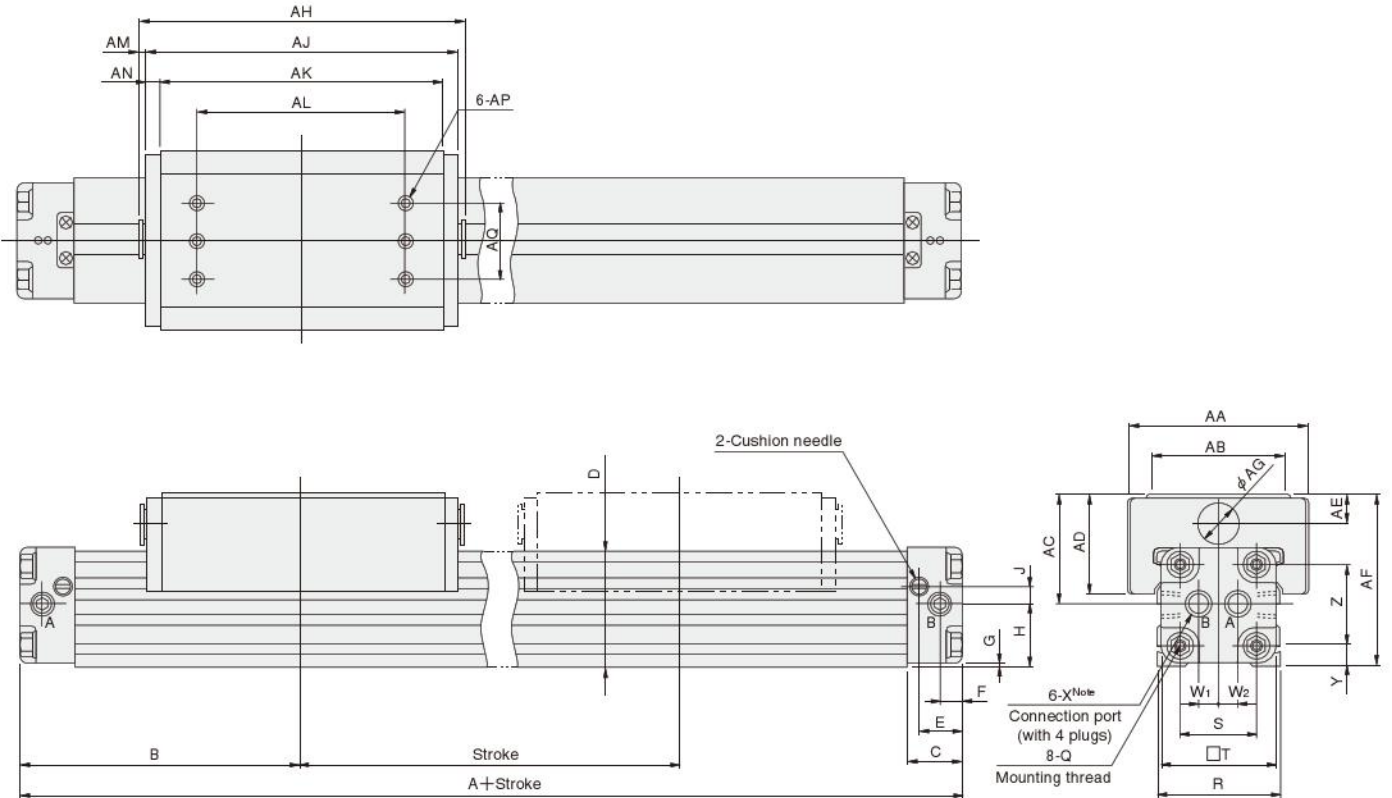

Note: ORGA16, 20, and 25 have 4 places.

Bore mm [in.]	Code	A	B	C	D	E	F	G	H	J	Q	R	S	T	W ₁	W ₂	X
16	[0.630]	130	65	15	27	12	5.5	1.5	15	4	M3×0.5 Depth5	31	18	27	7	7	M5×0.8 Depth4
20	[0.787]	160	80	19	34.5	16	7.5	2	19	6.5	M4×0.7 Depth7	39	24	34	5.5	9.5	Rc1/8
25	[0.984]	200	100	23	40	18	8.5	2	22	6.5	M5×0.8 Depth9	44	27	40	6	10	Rc1/8
32	[1.260]	250	125	27	54	21.5	10.5	4	30	8.5	M6×1 Depth15	56	36	52	11	11	Rc1/4
40	[1.575]	300	150	30	60	23.5	12	2	32	9	M6×1 Depth15	64	42	60	11	11	Rc1/4
50	[1.969]	320	160	32	75	24	13	3	40	14	M8×1.25 Depth15	78	52	74	14	14	Rc3/8

Bore mm [in.]	Code	Y	Z	AA	AB	AC	AD	AE	AF	AG	AH	AJ	AK	AL	AM	AN	AP	AQ
16	[0.630]	6	18	45	35	27	23.5	7.5	42	10	70	—	56	45	—	7	M3×0.5 Depth7	22
20	[0.787]	7	24	56	46	33	28.5	8.5	52	12	88	—	74	55	—	7	M4×0.7 Depth8	30
25	[0.984]	8.5	27	65	50	38	34	10	60	14	110	105	90	70	2.5	7.5	M5×0.8 Depth9	35
32	[1.260]	12	36	80	60	48	42	12	78	18	145	140	125	90	2.5	7.5	M6×1 Depth13	38
40	[1.575]	11	42	95	70	58	52	16	90	20	170	165	150	110	2.5	7.5	M6×1 Depth15	40
50	[1.969]	14	52	120	90	67	60	18	107	22	180	—	162	120	—	9	M8×1.25 Depth17	50

Option (mm)

Shock absorber: -K



Stroke adjusting bolt: -S

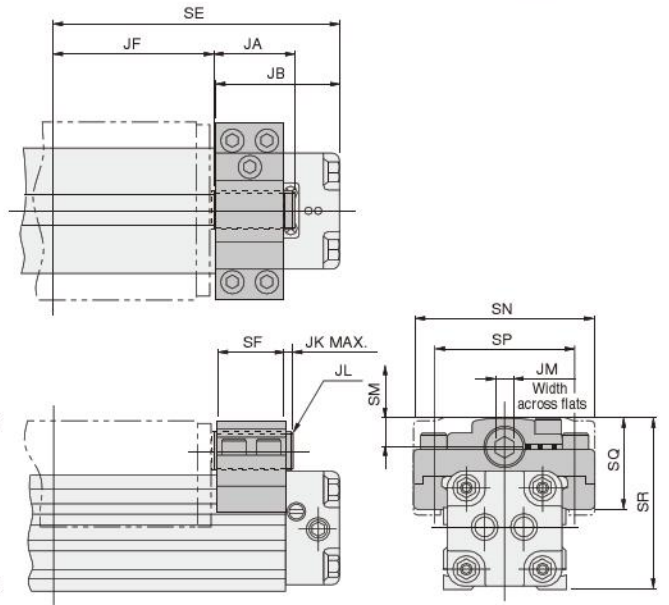
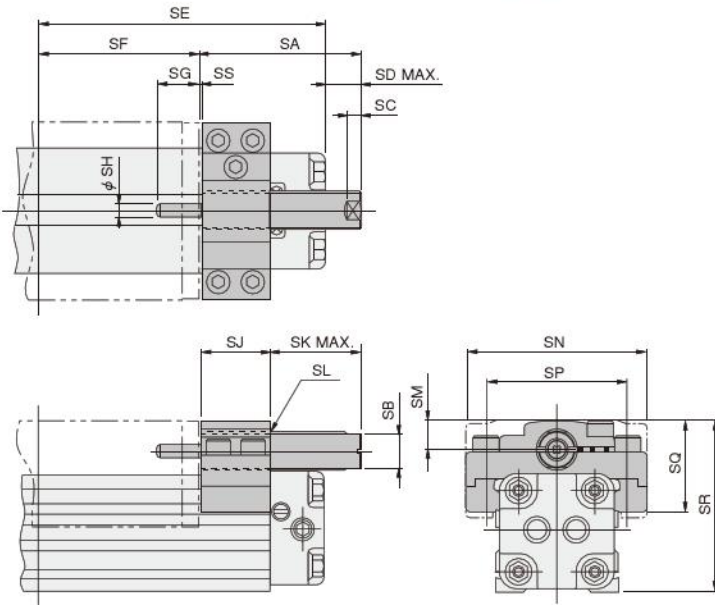

Bore mm [in.]	Code	SA	SB	SC	SD	SE	SF	SG	SH	SJ	SK
16 [0.630]		50	8.5	5	20	65	35	10	3	14.5	35
20 [0.787]		56	10.5	5	20	80	44	10	3	16.5	39
25 [0.984]		60	12	5	15	100	55	12	4	21	38
32 [1.260]		72	15	7	19.5	125	72.5	16	5	24.5	46.5
40 [1.575]		77	17	7	12	150	85	16	5	34	42
50 [1.969]		100	19	10	30	160	90	25	6	37	63

Bore mm [in.]	Code	JA	JB	SE	SF	JF	JK	JL	SM	SN
16 [0.630]		21	29.5	65	14.5	35	6	M10×1	7	44
20 [0.787]		24	35.5	80	16.5	44	7	M12×1	8	55
25 [0.984]		31	44	100	21	55	9	M14×1.5	9.5	64
32 [1.260]		36	51.5	125	24.5	72.5	10.5	M18×1.5	11.5	79
40 [1.575]		41	64	150	34	85	6	M20×1.5	15.5	94
50 [1.969]		46	69	160	37	90	8	M22×1.5	17	118

Bore mm [in.]	Code	SL	SM	SN	SP	SQ	SR	SS
16 [0.630]		M10×1	7	44	36	22	41.5	0.5
20 [0.787]		M12×1	8	55	45	26.5	51.5	0.5
25 [0.984]		M14×1.5	9.5	64	51	31.5	59.5	1
32 [1.260]		M18×1.5	11.5	79	64	39	77.5	1
40 [1.575]		M20×1.5	15.5	94	76	48	89.5	1
50 [1.969]		M22×1.5	17	118	92	53.5	106	1

Bore mm [in.]	Code	SP	SQ	SR	JM
16 [0.630]		36	22	41.5	5
20 [0.787]		45	26.5	51.5	6
25 [0.984]		51	31.5	59.5	6
32 [1.260]		64	39	77.5	8
40 [1.575]		76	48	89.5	10
50 [1.969]		92	53.5	106	12

L-type bracket: -L



F-type support: -F

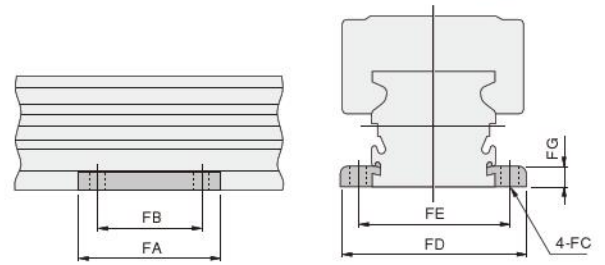
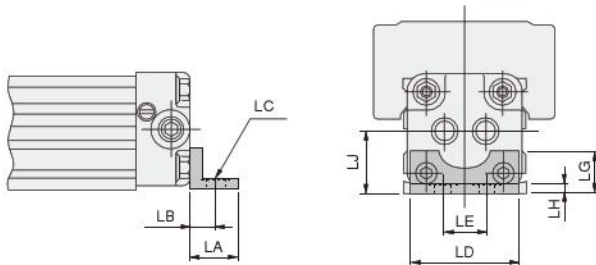

Bore mm [in.]	Code	LA	LB	LC	LD	LE	LG	LH	LJ
16 [0.630]		14	10	4-φ 3.6	26	18	10	1.6	15
20 [0.787]		18	13	4-φ 4.6	33	24	13	2	19
25 [0.984]		22	16	4-φ 5.8	39	27	16	2.6	22
32 [1.260]		26	18	4-φ 6.6	50	36	20	3.2	30
40 [1.575]		24	12.5	4-φ 9, φ 14 Counterbore Depth 1	58	24	21	5	32
50 [1.969]		32	22	4-φ 9	72	52	24	4	40

Bore mm [in.]	Code	FA	FB	FC	FD	FE	FG
16 [0.630]		40	28	3.4	45	38	5
20 [0.787]		50	35	4.5	57	48	6.3
25 [0.984]		50	35	5.5	70	58	8
32 [1.260]		65	45	6.6	82	70	8
40 [1.575]		75	55	9	96	80	10
50 [1.969]		75	55	9	110	94	10

Note: Do not install sensor switches in place on the cylinder that will interfere with the F-type support.

SLIT TYPE RODLESS CYLINDERS ORCA, ORGA SERIES

SENSOR SWITCHES

Solid State Type, Reed Switch Type

Order Codes for Sensor Switch

● Sensor switch (with mounting bracket)

		Sensor switch model	Lead wire length	Cylinder basic type	Bore size
Solid state type	2-lead wire with indicator lamp	DC10~28V ZG530	A B	-ORCA -ORGA	16 20 25 32 40 50
Solid state type	3-lead wire with indicator lamp	DC4.5~28V ZG553			
Reed switch type	2-lead wire with indicator lamp	DC10~30V AC85~230V CS3M			
Reed switch type	2-lead wire with indicator lamp	DC10~30V AC85~115V CS4M			
Reed switch type	2-lead wire without indicator lamp	DC3~30V AC85~115V CS5M			

● For details of sensor switches, see p.1544.

● **A** : 1000mm [39in.]
 ● **B** : 3000mm [118in.]
 ● **ORCA** : For ORCA
 ● **ORGA** : For ORGA

● Order codes for mounting bracket only

G5 — [] []

Cylinder basic type
ORCA : For ORCA
ORGA : For ORGA

Bore size
16 : For ϕ 16 [0.630in.]
20 : For ϕ 20 [0.787in.]
25 : For ϕ 25 [0.984in.]
32 : For ϕ 32 [1.260in.]
40 : For ϕ 40 [1.575in.]
50 : For ϕ 50 [1.969in.]

Sensor Switch Operating Range, Response Differential, and Maximum Sensing Location

● Operating range: ℓ

The distance the piston travels in one direction, while the switch is in the ON position.

● Response differential: C

The distance between the point where the piston turns the switch ON and the point where the switch is turned OFF as the piston travels in the opposite direction.

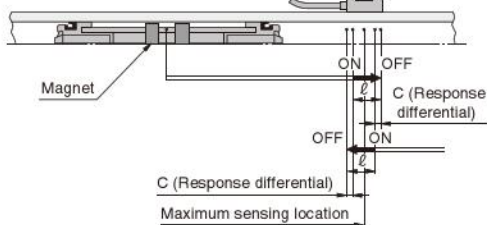

Bore size mm [in.]	ZG530□, ZG553□			CS□M□		
	Operating range	Response differential	Maximum sensing location*	Operating range	Response differential	Maximum sensing location*
16 [0.630]	3.3~5.5 [0.130~0.217]	0.6 [0.024] or less	11 [0.433]	9~11 [0.35~0.43]	1.5 [0.059] or less	11 [0.433]
20 [0.787]	3.8~6.4 [0.150~0.252]	0.7 [0.028] or less		10~14 [0.39~0.55]	1.5 [0.059] or less	
25 [0.984]	4.1~6.9 [0.161~0.272]	0.7 [0.028] or less		13~15 [0.51~0.59]	1.5 [0.059] or less	
32 [1.260]	5.0~8.3 [0.197~0.327]	0.8 [0.031] or less		15~21 [0.59~0.83]	2 [0.079] or less	
40 [1.575]	6.5~10.9 [0.256~0.429]	0.8 [0.031] or less		15~24 [0.59~0.94]	2.5 [0.098] or less	
50 [1.969]	8.2~13.6 [0.323~0.535]	1.0 [0.039] or less	20~28 [0.79~1.10]	2.5 [0.098] or less		

Remark: Values in the above table are reference values.

※: This is the length measured from the switch's opposite end side to the lead wire.

Note: Take note when installing a sensor switch in the middle of a stroke, because when the piston speed is fast, the switch is ON for a short time, and such as relays may not respond.

$$\text{ON time [ms]} = (\text{operating range [mm]} / \text{piston speed [mm/s]}) \times 10^3$$

Moving Sensor Switch

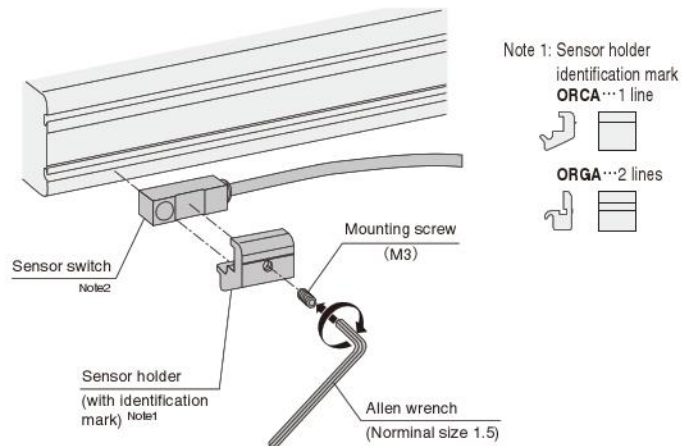

The sensor switch can be moved in the direction of the stroke by loosening the mounting screw of the sensor holder with an Allen wrench.

(Tightening torque 0.2N·m [1.8in·lbf])

Note 2: Pull out the lead wire as follows when you install a solid state type sensor switch on **ORCA16, 20, 25**.

- Install the sensor holder upward when you pull out the lead wire to the left.

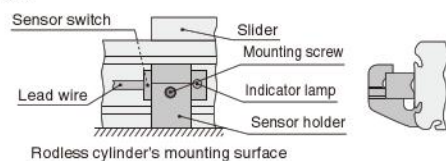

- Install the sensor holder downward when you pull out the lead wire to the right.

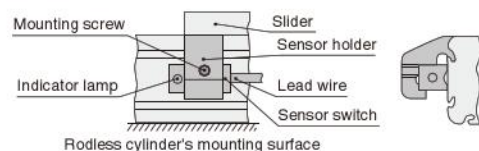

Dimensions and Mounting Location of Sensor Switch

When the sensor switch is mounted in the locations shown below, the magnet comes to the maximum sensing location of the sensor switch at the end of the stroke.

 ORCA-SW1
ORCA-SW2
ORGA-SW1
ORGA-SW2

● ORCA basic type, ORGA

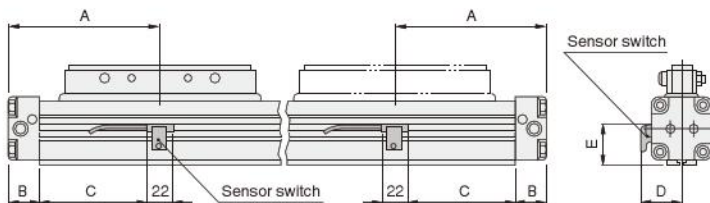

		mm [in.]				
Bore mm [in.]	Code	A	B	C	D	E
16 [0.630]	65 [2.560]	15 [0.591]	39 [1.535]	24.5 [0.965]	20 [0.787]	
20 [0.787]	80 [3.150]	19 [0.748]	50 [1.969]	28 [1.102]	24 [0.945]	
25 [0.984]	100 [3.937]	23 [0.906]	66 [2.598]	30 [1.181]	28 [1.102]	
32 [1.260]	125 [4.921]	27 [1.063]	87 [3.425]	34 [1.339]	36 [1.417]	
40 [1.575]	150 [5.906]	30 [1.181]	109 [4.291]	39 [1.535]	41 [1.614]	
50 [1.969]	160 [6.299]	32 [1.260]	117 [4.606]	45 [1.772]	46 [1.811]	

		mm [in.]				
Bore mm [in.]	Code	A	B	C	D	E
16 [0.630]	65 [2.560]	15 [0.591]	39 [1.535]	22 [0.866]	17.5 [0.689]	
20 [0.787]	80 [3.150]	19 [0.748]	50 [1.969]	25.5 [1.004]	22.5 [0.886]	
25 [0.984]	100 [3.937]	23 [0.906]	66 [2.598]	29 [1.142]	24.5 [0.965]	
32 [1.260]	125 [4.921]	27 [1.063]	87 [3.425]	35 [1.378]	33.5 [1.319]	
40 [1.575]	150 [5.906]	30 [1.181]	109 [4.291]	39 [1.535]	35.5 [1.398]	
50 [1.969]	160 [6.299]	32 [1.260]	117 [4.606]	45 [1.772]	43.5 [1.713]	

● ORCA dual piston type

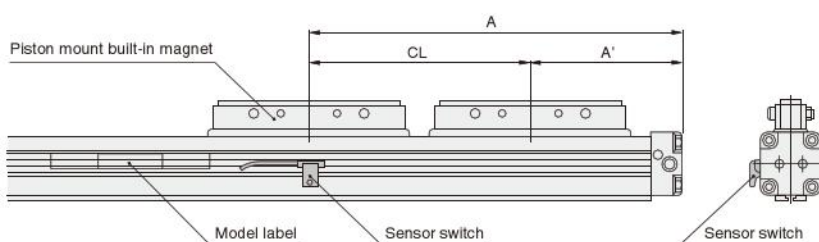

		mm [in.]	
Bore mm [in.]	Code	CL ^{Note}	A'
32 [1.260]	180 [7.09]	305 [12.01]	
40 [1.575]	220 [8.66]	370 [14.57]	
50 [1.969]	240 [9.45]	400 [15.75]	

Note: The dimension CL shows the minimum case value.

● Lead wire holder

One lead wire holder for ORCA is included.

Use it as shown below.

It can also be ordered separately.

Order code: **LH-ORCA** (5 pcs./set)

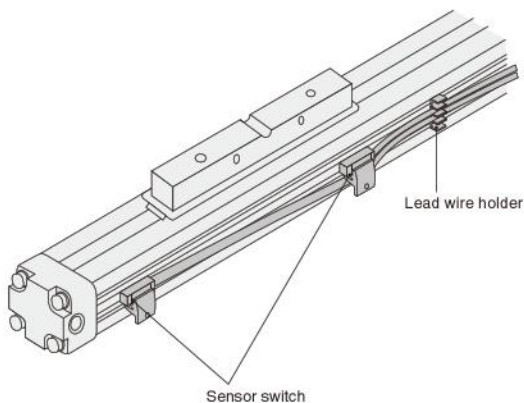

Handling Instructions and Precautions



Selection and Mounting

Allowable load and moment

Although the slit type rodless cylinders ORCA, ORGA series can be used with directly applying loads, make sure that the load and moment do not exceed the values in the table below.

● ORCA

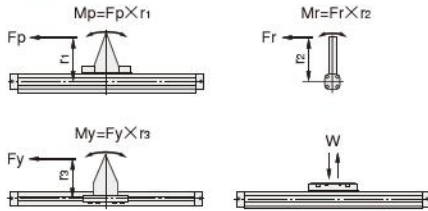

Pitching moment : $M_p = F_p \times r_1$ [N·m]
Rolling moment : $M_r = F_r \times r_2$ [N·m]
Yawing moment : $M_y = F_y \times r_3$ [N·m]
Maximum load capacity : W [N]

Bore size mm [in.]	Standard specification			
	M_p N·m [ft·lbf]	M_r N·m [ft·lbf]	M_y N·m [ft·lbf]	W N [lbf.]
16 [0.630]	3.9 [2.9]	0.3 [0.2]	0.5 [0.4]	117 [26.3]
20 [0.787]	7.8 [5.8]	0.8 [0.6]	1.2 [0.9]	196.1 [44.1]
25 [0.984]	14.7 [10.8]	1.0 [0.7]	2.0 [1.5]	294.2 [66.1]
32 [1.260]	29.4 [21.7]	2.0 [1.5]	4.9 [3.6]	490.3 [110.2]
40 [1.575]	58.8 [43.4]	3.9 [2.9]	7.8 [5.8]	735.5 [165.3]
50 [1.969]	112.8 [83.2]	6.9 [5.1]	14.7 [10.8]	1176.8 [264.5]

Bore size mm [in.]	Dual piston specification			
	M_p N·m [ft·lbf]	M_r N·m [ft·lbf]	M_y N·m [ft·lbf]	W N [lbf.]
16 [0.630]	7.8 [5.8]	0.6 [0.4]	1.5 [1.1]	235 [52.8]
20 [0.787]	15.7 [11.6]	1.6 [1.2]	3.5 [2.6]	392 [88.1]
25 [0.984]	29.4 [21.7]	2.0 [1.5]	5.9 [4.4]	588 [132.2]
32 [1.260]	58.8 [43.4]	3.9 [2.9]	14.7 [10.8]	981 [220.5]
40 [1.575]	117.7 [86.8]	7.8 [5.8]	23.5 [17.3]	1471 [330.7]
50 [1.969]	225.6 [166.4]	13.7 [10.1]	44.1 [32.5]	2354 [529.2]

Remark : The rolling angle (inclined angle) of the piston mount, when the allowable rolling moment is applied, is as follows, for both sides together. ϕ 16 [0.630in.]: within about 3°, ϕ 20 [0.787in.]: within about 3°, ϕ 25, 32 [0.984, 1.260in.]: within about 1.5°, ϕ 40 [1.575in.]: within about 1°, ϕ 50 [1.969in.]: within about 1°

● ORGA

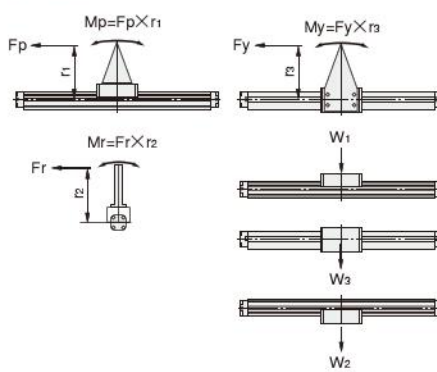

Pitching moment : $M_p = F_p \times r_1$ [N·m]
Rolling moment : $M_r = F_r \times r_2$ [N·m]
Yawing moment : $M_y = F_y \times r_3$ [N·m]
Maximum load capacity : W_1, W_2, W_3 [N]

Bore size mm [in.]	M_p N·m [ft·lbf]	M_r N·m [ft·lbf]	M_y N·m [ft·lbf]	W_1 N [lbf.]	W_2 N [lbf.]	W_3 N [lbf.]
16 [0.630]	3.9 [2.9]	1.5 [1.1]	0.5 [0.4]	78.5 [17.6]	39.2 [8.8]	11.8 [2.7]
20 [0.787]	7.8 [5.8]	3.9 [2.9]	1.2 [0.9]	137.3 [30.9]	68.6 [15.4]	19.6 [4.4]
25 [0.984]	14.7 [10.8]	4.9 [3.6]	2.0 [1.5]	196.1 [44.1]	98.1 [22.1]	29.4 [6.6]
32 [1.260]	29.4 [21.7]	9.8 [7.2]	4.9 [3.6]	313.8 [70.5]	156.9 [35.3]	47.1 [10.6]
40 [1.575]	58.8 [43.4]	19.6 [14.5]	7.8 [5.8]	490.3 [110.2]	245.2 [55.1]	73.5 [16.5]
50 [1.969]	112.8 [83.2]	34.3 [25.3]	14.7 [10.8]	784.5 [176.4]	392.3 [88.2]	117.7 [26.5]

Remark : The rolling angle (inclined angle) of the slider, when the allowable rolling moment is applied, is as follows, for both sides together. ϕ 16 [0.630in.]: within about 3°, ϕ 20 [0.787in.]: within about 3°, ϕ 25, 32 [0.984, 1.260in.]: within about 1.5°, ϕ 40 [1.575in.]: within about 1°, ϕ 50 [1.969in.]: within about 1°

- Cautions:**
- The moment including the inertial force generated when the load is moved or stopped must not exceed the values in the above table. For the mass and the piston speed, see the [Cushioning capacity].
 - Rolling moment: M_r should not be applied as much as possible.

Cushioning capacity

While variable cushions are standard equipment on all slit type rodless cylinders, keep the maximum mass and speed within the ranges shown in the graph below. If load and speed exceed the ranges, install an external shock absorber, etc., to absorb the shock.

Cushion stroke		mm [in.]
Bore size	Cushion stroke	
16 [0.630]	15 [0.591]	
20 [0.787]	18 [0.709]	
25 [0.984]	21 [0.827]	
32 [1.260]	26 [1.024]	
40 [1.575]	40 [1.575]	
50 [1.969]	40 [1.575]	

● ORCA

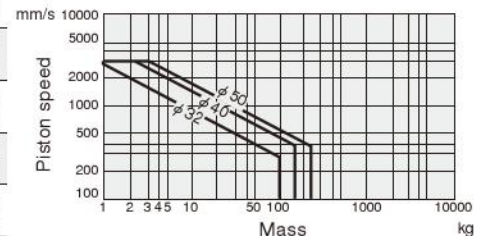
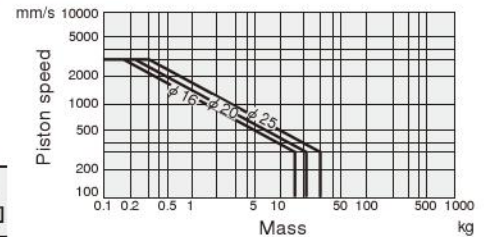

1mm/s = 0.0394in./sec.
1kg = 2.205lb.

● ORGA

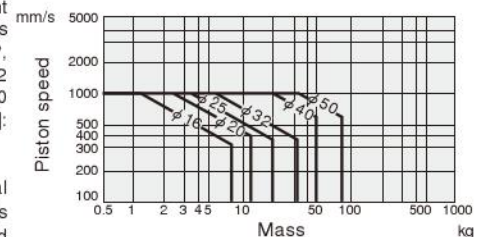

1mm/s = 0.0394in./sec.
1kg = 2.205lb.

- Cautions:**
- For the maximum operating speed, see the specifications table. (ORCA series: p.1077; ORGA series: p.1088). Consult us when you exceed the values indicated in the specification tables.
 - The mass shown in the graph is the total mass carried by the rodless cylinder.
 - Adjust cushions according to the piston speed and the mass, and absorb the impacts effectively.

Support

A long stroke and large load may cause deflection in the cylinder body. In this case, it is also necessary to support the intermediate position so that the support span: l is below the graph, as shown in the tables below. The intermediate portion can be easily supported by installing the necessary number of F- or G-type supports to the cylinder body.

●ORCA mm [in.]

Bore size	Support span: l	
	Standard specification	Dual piston specification
16 [0.630]	Stroke+130 [5.12]	Stroke+215 [8.46]
20 [0.787]	Stroke+160 [6.30]	Stroke+265 [10.43]
25 [0.984]	Stroke+200 [7.87]	Stroke+335 [13.19]
32 [1.260]	Stroke+250 [9.84]	Stroke+430 [16.93]
40 [1.575]	Stroke+300 [11.81]	Stroke+520 [20.47]
50 [1.969]	Stroke+320 [12.60]	Stroke+560 [22.05]

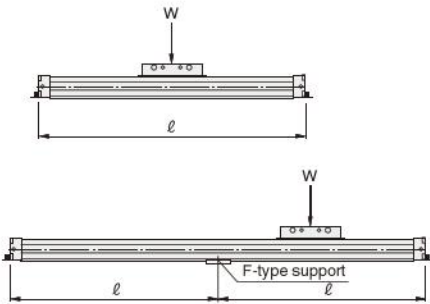

●ORGA mm [in.]

Bore size	Support span: l
16 [0.630]	Stroke+130 [5.12]
20 [0.787]	Stroke+160 [6.30]
25 [0.984]	Stroke+200 [7.87]
32 [1.260]	Stroke+250 [9.84]
40 [1.575]	Stroke+300 [11.81]
50 [1.969]	Stroke+320 [12.60]

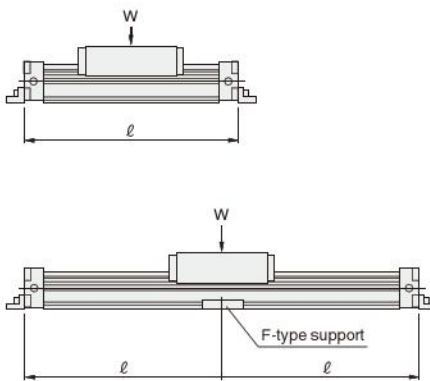

Note: Do not install sensor switches in place on the cylinder that will interfere with the F-type support in the ORGA series.

Precaution when using F-type support and L-type bracket for ORCA simultaneously

When L-type brackets are installed together with F-type supports, and the L-type brackets are used as shown in the diagram ① below, the cylinder installation position becomes low, and the F-type supports cannot go in. L-type brackets should be used as shown in the diagram ② below so the distance becomes $FF=LF_2$.

Note: Caution should be exercised that the pitch of the mounting hole changes due to installing direction of L-type brackets.

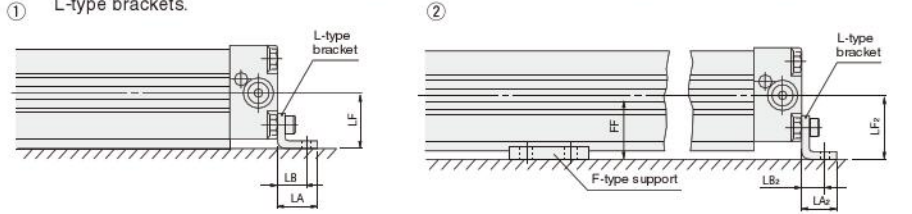

Bore size [mm]	Code	FF	LF	LF ₂	LA	LA ₂	LB	LB ₂
16 [0.630]		19 [0.75]	15 [0.59]	19 [0.75]	14 [0.55]	10 [0.39]	10 [0.39]	6 [0.24]
20 [0.787]		25 [0.98]	19 [0.75]	25 [0.98]	18 [0.71]	13 [0.51]	13 [0.51]	7 [0.28]
25 [0.984]		29.5 [1.16]	22 [0.87]	29.5 [1.16]	22 [0.87]	16 [0.63]	16 [0.63]	8.5 [0.33]
32 [1.260]		36 [1.42]	30 [1.18]	36 [1.42]	26 [1.02]	20 [0.79]	18 [0.71]	12 [0.47]
40 [1.575]		39 [1.54]	35 [1.38]	39 [1.54]	26 [1.02]	22 [0.87]	18 [0.71]	14 [0.55]
50 [1.969]		48 [1.89]	40 [1.57]	48 [1.89]	32 [1.26]	24 [0.94]	22 [0.87]	14 [0.55]

●ORCA16, 20, 25

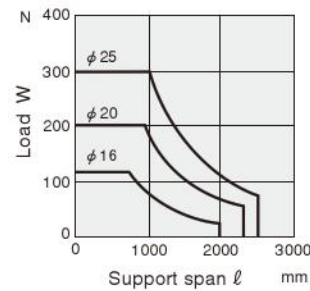

●ORCA32, 40, 50

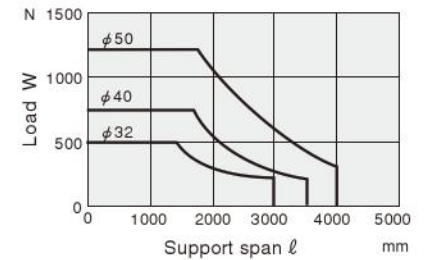

●ORCAD16, 20, 25

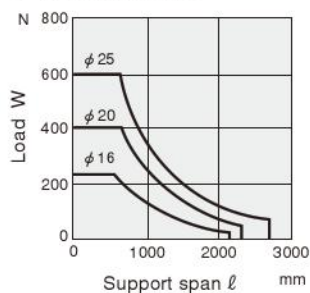

●ORCAD32, 40, 50

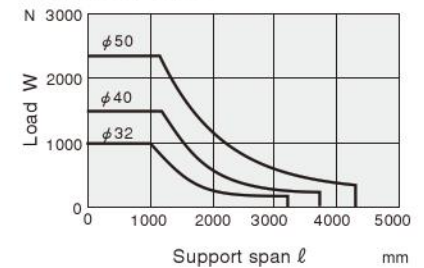

●ORGA16, 20, 25

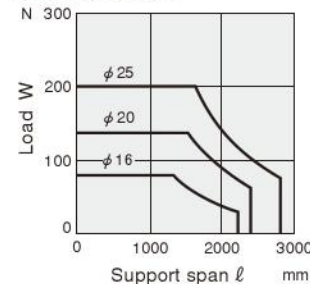

●ORGA32, 40, 50

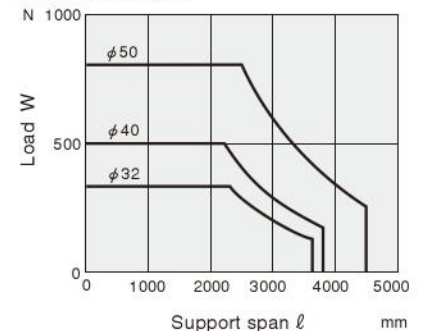

1N = 0.2248lbf. 1mm = 0.0394in.

Handling Instructions and Precautions

Mounting

1. While any mounting direction is allowed, mount the piston yoke so that it faces downward, or protect the seal band with a cover, etc., when mounting in locations subject to dripping water or oil, etc., or to large amounts of dust.
2. Avoid any electric welding either during or after mounting the rodless cylinder. Flows of welding current to the cylinder could generate arcs that result in damage or depositions.

Caution: Avoid applying strong shocks to the cylinder body's slit portion.

Intermediate stop control

Since for structural reasons external air leakage is inevitable for the slit type rodless cylinders, use of all port block 3-position valves, etc., for intermediate stop control could result in failure to maintain the stopping position, and the piston speed could not be controlled when restarting. We recommend, therefore, double-sided pressure control circuits that use PAB-connection 3-position valves, etc. For intermediate stopping control under constant loads, such as vertical mountings, consult us.

Stroke adjustment

● When using with a shock absorber

When using with a shock absorber, the stroke can be easily adjusted over entire cylinder strokes. First, all 4 holder mounting bolts should be loosened and move the holder so that the stroke should be roughly determined. Then tighten the holder mounting bolts to secure the holder. Next, loosen the shock absorber mounting bolt, then finely adjust the shock absorber mounting location by rotating the shock absorber body by hand or with a wrench. After adjustment, tighten the shock absorber mounting bolt and secure the shock absorber. The stroke can be adjusted in the range of $\phi 16$ [0.630in.]: 15mm [0.59in.] on one side, $\phi 20$ [0.787in.], $\phi 25$ [0.984in.]: 20mm [0.79in.] on one side, $\phi 32$ [1.260in.], $\phi 40$ [1.575in.], $\phi 50$ [1.969in.]: 30mm [1.18in.] on one side. When adjustments are required for over this range, the holder should be moved. If a shock absorber is used with an variable cushion, it might rebound. When it is required to stop at the end of the stroke using a shock absorber, the adjusting cushion needle should be fully opened.

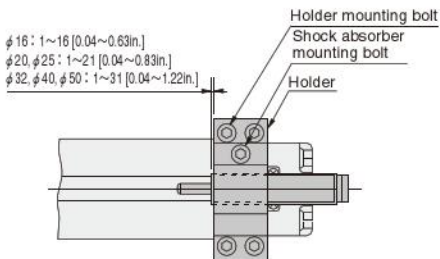

Calculation of impact energy

Horizontal Impact	
$E = E_1 + E_2$ $= \frac{m \cdot v^2}{2} + F_o \cdot L$	$E' = E'_1 + E'_2$ $= \frac{W' \cdot v'^2}{2g'} + F'_o \cdot L'$

Vertical Impact ^{Note 1}			
When descending ^{Note 2}		When ascending	
$E = E_1 + E_2 + E_3$ $= \frac{m \cdot v^2}{2} + F_o \cdot L + m \cdot g \cdot L$	$E' = E'_1 + E'_2 + E'_3$ $= \frac{W' \cdot v'^2}{2g'} + F'_o \cdot L' + W' \cdot L'$	$E = E_1 + E_2 - E_3$ $= \frac{m \cdot v^2}{2} + F_o \cdot L - m \cdot g \cdot L$	$E' = E'_1 + E'_2 - E'_3$ $= \frac{W' \cdot v'^2}{2g'} + F'_o \cdot L' - W' \cdot L'$

Note 1: For impact on incline, E_3 becomes $E'_3 = m \cdot g \cdot L \cdot \sin \theta$.

Note 1: For impact on incline, E'_3 becomes $E''_3 = W' \cdot L' \cdot \sin \theta$.

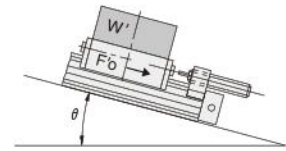
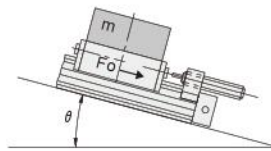

Note 2: When descending, the operating air pressure: P, should be lower than when ascending, because heavier loads can be carried.

- E : Total impact energy ... [J]
- E_1 : Kinetic energy ... $\frac{m \cdot v^2}{2}$ [J]
- E_2 : Additional energy by cylinder thrust ... $F_o \cdot L$ [J]
- E_3 : Additional energy by load mass ... $m \cdot g \cdot L$ [J]
- m : Load mass [kg]
- v : Impact speed [m/s]
- g : Gravity acceleration 9.8 [m/s²]
- F_o : Cylinder thrust ... $= \frac{\pi}{4} \cdot D^2 \cdot P$ [N]
- [D: Cylinder bore (mm) P: Operating air pressure (MPa)]
- L : Absorbing stroke of shock absorber [m]

Note 2: When descending, the operating air pressure: P', should be lower than when ascending, because heavier loads can be carried.

- E' : Total impact energy ... [ft·lbf]
- E'_1 : Kinetic energy ... $\frac{W' \cdot v'^2}{2g'}$ [ft·lbf]
- E'_2 : Additional energy by cylinder thrust ... $F'_o \cdot L'$ [ft·lbf]
- E'_3 : Additional energy by load weight ... $W' \cdot L'$ [ft·lbf]
- W' : Load weight [lbf]
- v' : Impact speed [ft./sec.]
- g' : Gravity acceleration 32.2 [ft./sec.]
- F'_o : Cylinder thrust ... $= \frac{\pi}{4} \cdot D'^2 \cdot P'$ [lbf]
- [D': Cylinder bore [in.] P': Operating air pressure [psi.]]
- L' : Absorbing stroke of shock absorber [ft.]

Impact speed and mass of impact object

Graph of the impact speed and mass of impact object

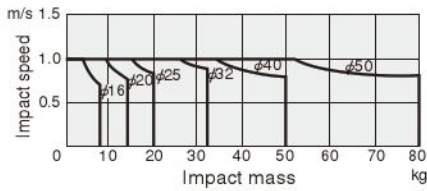

Remark: Horizontal impact

The air pressure is 0.5MPa [73psi.], and a shock absorber is used.

1m/s = 3.28ft./sec. 1kg = 2.205lb.

- Cautions:**
1. Tighten the 4 holder mounting bolts equally so that the striker evenly hits the front surface of the shock absorber.
 2. Use the shock absorber within the range of the specifications.
 3. Set the load so that the impact energy does not exceed the maximum absorption of the shock absorber.
 4. The maximum impact speed to the optional shock absorber is 1000mm/s [39.4in./sec.].
 5. The speed at the moment of impact with the shock absorber should not exceed 1000mm/s [39.4in./sec.]. Care should be taken that this is likely to greatly differ from the average speed of the cylinder.
 6. If using in locations subject to dripping water, dripping oil, etc., or to large amounts of dust, use a cover to protect the unit. Oil, water or dust on the shock absorber rod can reduce the life of the shock absorber.
 7. Do not loosen or remove the screw on the rear end of the shock absorber. Oil sealed inside will leak, damaging the shock absorber function.

When using with a stroke adjusting bolt

When using with a stroke adjusting bolt, fine adjustment of the stroke can be made at the end of the stroke. Loosen the mounting bolt for stroke adjusting bolt, then finely adjust the stroke by rotating the stroke adjusting bolt, and after adjustment, tighten the mounting bolt for stroke adjusting bolt and secure the stroke adjusting bolt.

Stroke adjusting range of stroke adjusting bolt

Bore size	Stroke adjusting range (one side) mm [in.]
16 [0.630]	4 [0.16]
20 [0.787]	5 [0.20]
25 [0.984]	6 [0.24]
32 [1.260]	8 [0.32]
40, 50 [1.575, 1.969]	10 [0.39]

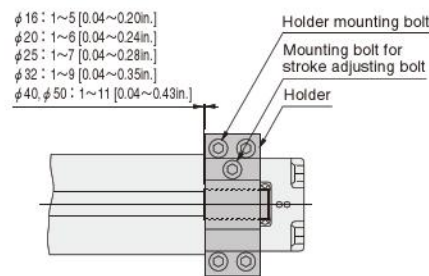

Tightening torque of the holder mounting bolt

Bore size mm [in.]	Tightening torque N-cm [in.-lbf]
16 [0.630]	117.7 [10.4]
20 [0.787]	274.6 [24.3]
25 [0.984]	588.4 [52.1]
32 [1.260]	980.7 [86.8]
40 [1.575]	1961.3 [173.6]
50 [1.969]	3922.7 [347.2]

- Cautions:**
1. Stroke adjustment should not be done by moving the holder. Use the holder with a shock absorber when over a wide range stroke adjustment is required.
 2. The cushion stroke is shortened when finely adjust the stroke, and the shock absorption of the variable cushion decreases. The cushion capacity decreases by about 30% when the stroke adjustment is maximized.



General precautions

Piping

Always thoroughly blow off (use compressed air) the tubing before connecting it to the slit type rodless cylinder. Entering chips, sealing tape, rust, etc., generated during piping work could result in air leaks or other defective operation.

Atmosphere

1. If using in locations subject to dripping water, dripping oil, etc., or to large amounts of dust, the band may break or the life of the seals could be shortened. Use a cover to protect the unit or mount with the piston yoke facing downward.
2. Do not engage in electric welding close to the rodless cylinder. The welding spatters could damage the outer seal band.
3. The product cannot be used when the media or ambient atmosphere contains any of the substances listed below.
Organic solvents, phosphate ester type hydraulic oil, sulphur dioxide, chlorine gas, or acids, etc.

Lubrication

The product can be used without lubrication, if lubrication is required, use Turbine Oil Class 1 (ISO VG32) or equivalent.

Media

1. Use air for the media. For the use of any other media, consult us.
2. Air used for the rodless cylinder should be clean air that contains no deteriorated compressor oil, etc. Install an air filter (filtration of a minimum 40 μm) near the rodless cylinder or valve to remove collected liquid or dust. In addition, drain the air filter periodically.

Handling Instructions and Precautions

Maintenance

The rodless cylinders **ORCA**, **ORGA** series are structurally incapable of completely preventing air leakage to the outside. Nevertheless, particles adhering to the inner seal band are the most common cause of initial-staged air leakages, and this type of failure is easily remedied.

First, loosen the outer seal band setscrews, remove the outer seal band, and apply approx. 0.1MPa [15psi.] of air pressure to the rodless cylinder. Next, insert a cleaning tool inside the cylinder barrel slit and then, while pressing down the inner seal band and moving it along the slit, use air to blow off the particles.

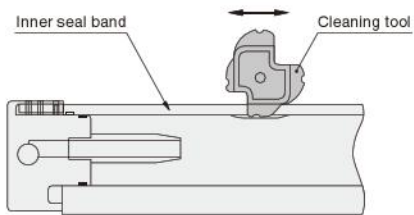

- Cautions:**
1. Always use protective glasses during working.
 2. When performing maintenance, use the special cleaning tool. Use of a screwdriver or other tool could damage the inner seal band or cylinder barrel.
 3. If the above maintenance fails to stop the air leakage, follow instructions in the user's manual to perform a cylinder overhaul.