

RODLESS CYLINDERS

φ 63, φ 80



Features

- A long stroke of up to 5000mm [196.8in.] can be manufactured. It can also be used to make driving equipment, which could not be done by air cylinders in the past.
- The magnet for the sensor switch is standard equipment. By installing a sensor switch, the piston position can be easily detected, and the space for the limit switch mounting and design man-hours can be greatly reduced.
- Upside down installation mountings have been put into a series. By installing the piston yoke facing downwards, the seal band is protected, thereby increasing its durability.

Symbols

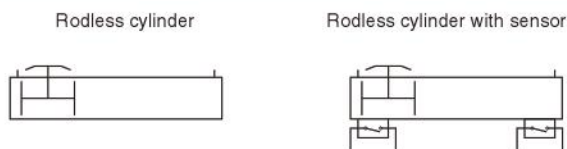

Specifications

Bore size	φ 63 [2.480In.]	φ 80 [3.150In.]
Media	Air	
Operation type	Double acting type	
Operating pressure range MPa [psi.]	0.1~0.8 [15~116]	
Proof pressure MPa [psi.]	1.2 [174]	
Operating temperature range °C [°F]	0~60 [32~140]	
Operating speed range mm/s [in./sec.]	100~1500 [3.9~59.1] ^{Note1}	
Cushion	Both sides (Variable cushion)	
Lubrication	Required ^{Note2}	
Port size	Rc3/8	Rc1/2
Maximum stroke	mm 5000	
Stroke tolerance mm [in.]	1000 or less	+2 ₀ +0.079 ₀
	1001~3000	+3 ₀ +0.118 ₀
	3001~5000	+4 ₀ +0.157 ₀

Notes: 1. Consult us when the cylinder speed exceeds 1500mm/s [59.1in./sec.]
 2. However, it is not required for a cylinder speed of 500mm/s [19.7in./sec.] or less. For the recommended oil, see the recommended oil list.

Remark: For details of sensor switches, see p.1544.

Order Codes

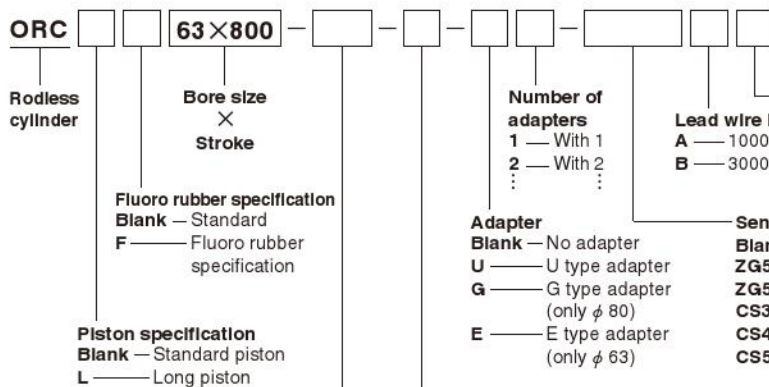

- Mount for piston mount**
 Blank — No mount
 T — With T mount (For standard piston)
 M — With M mount (For standard piston)
 C — With C mount (For standard piston)
 CT — With CT mount (For standard piston)
 CM — With CM mount (For standard piston)
 LT — With LT mount (For long piston)
 CL — With CL mount (For long piston)
 CLT — With CLT mount (For long piston)
- Adapter**
 Blank — No adapter
 U — U type adapter
 G — G type adapter (only φ 80)
 E — E type adapter (only φ 63)
- Mounting bracket**
 Blank — No mounting bracket
 L — With foot mounting bracket
- Number of adapters**
 1 — With 1
 2 — With 2
 ⋮ — With ⋮
- Lead wire length**
 A — 1000mm [39in.]
 B — 3000mm [118in.]
- Number of sensor switches**
 (For the cylinder with sensor)
 1 — With 1 sensor switch
 2 — With 2 sensor switches
 ⋮ — With ⋮ sensor switches
- Sensor switch** (For the cylinder with sensor)
 Blank — No sensor switch
 BZG530 — 2-lead wire Solid state type with indicator lamp DC10~28V
 ZG553 — 3-lead wire Solid state type with indicator lamp DC4.5~28V
 CS3M — 2-lead wire Reed switch type with indicator lamp DC10~30V, AC85~115V
 CS4M — 2-lead wire Reed switch type with indicator lamp DC10~30V, AC85~115V
 CS5M — 2-lead wire Reed switch type without indicator lamp DC3~30V, AC85~115V

- Since a magnet is already standard on the rodless cylinders, mounting a sensor switch will enable use in sensor switch applications.

● The mount for piston mount, the mounting bracket, and the adapter are included at shipping.

Bore Size and Stroke

Bore	Standard strokes	Available strokes
63	500, 600, 700, 800, 1000	100~5000 ^{Note}
	1200, 1400, 1600, 1800, 2000	
80	Manufactured upon receipt of order	

Remark: Non-standard strokes are available at 1mm pitch intervals. For delivery, consult us.
 Note: Consult us for strokes over 5000mm.

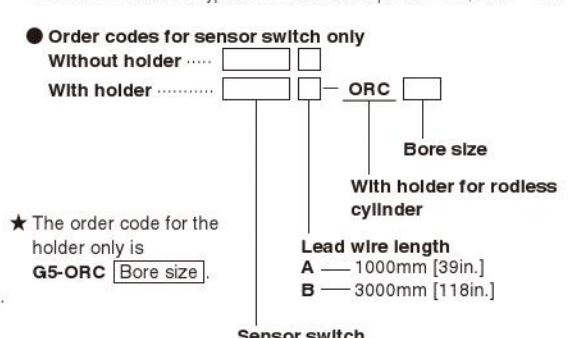

★ The order code for the holder only is G5-ORC [Bore size].

● For details of sensor switches, see p.1544.

Inner Construction

φ 63, φ 80

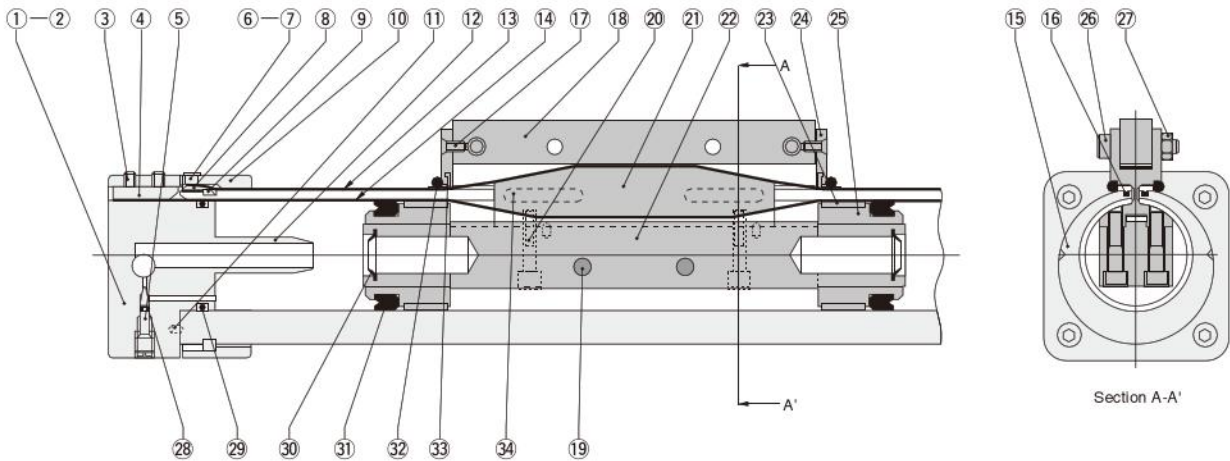

Major Parts and Materials

No.	Parts	Materials	Number	Remarks
①	End cover R ^{Note 1}	Aluminum (anodized)	1	
②	End cover L ^{Note 2}	Aluminum (anodized)	1	
③	Inner seal band setscrew	Alloy steel	4	Hexagon socket setscrew
④	Inner seal band lock	Aluminum (anodized)	2	
⑤	Cushion needle	Steel	2	
⑥	Outer seal band setscrew	Alloy steel	4	Slotted countersunk head screw
⑦	Cap	Nylon	2	
⑧	Outer seal band lock	Steel	2	
⑨	Lock ring	Zinc alloy	2	
⑩	Cap ring	Aluminum (anodized)	2	
⑪	Pin	Steel	6	
⑫	Cushion pipe	Aluminum (anodized)	2	
⑬	Outer seal band	Stainless chrome steel	1	For standard or long piston
⑭	Inner seal band	Stainless chrome steel	1	For standard or long piston
⑮	Cylinder barrel	Aluminum (anodized)	1	For standard or long piston
⑯	Magnet strip	Rubber magnet	2	For standard or long piston
⑰	Piston mount setscrew	Alloy steel	2	

No.	Parts	Materials	Number	Remarks
⑱	Piston mount	Aluminum (anodized)	1	For standard or long piston
⑲	Magnet	Alnico magnet	2	
⑳	Piston yoke setscrew	Alloy steel	4	8 pieces for a long piston type
㉑	Piston yoke	Aluminum (anodized)	1	For standard or long piston
㉒	Piston axle	Aluminum (anodized)	1	For standard or long piston
㉓	Wear ring	Polyethylene	2	
㉔	End plate	Aluminum (anodized)	2	
㉕	Piston end	Aluminum (anodized)	2	
㉖	Mount fixing bolt	Alloy steel	2	Hexagon socket head bolt
㉗	Mount fixing nut	Alloy steel	2	
㉘★	Cushion gasket	Synthetic rubber (NBR)	2	FPM for fluoro rubber specification
㉙★	Cylinder gasket	Synthetic rubber (NBR)	2	FPM for fluoro rubber specification
㉚★	Cushion seal	Synthetic rubber (NBR)	2	FPM for fluoro rubber specification
㉛★	Piston seal	Synthetic rubber (NBR)	2	FPM for fluoro rubber specification
㉜★	Scraper holding O-ring	Synthetic rubber (CR)	1	For standard or long piston
㉝★	Scraper	Polyacetal	2	
㉞★	Bearing strip	Polyethylene	4	8 pieces for a long piston type

Remark: Specify the bore size and the piston specification when ordering the parts.

Notes: 1. The end cover of **ORC63** can be used for right and left ends. In the case of **ORC80**, when facing connection ports, this is the left side one.

2. The end cover of **ORC63** can be used for right and left ends. In the case of **ORC80**, when facing connection ports, this is the right side one.

★: Available as a seal repair kit.

Mass

Standard piston

Bore size mm [in.]	Zero stroke mass (With short mount)	Additional mass for each 1mm [0.0394in.] stroke	Additional mass of mount for piston mount, mounting bracket, and adapter							kg [lb.]	
			T mount	M mount	C mount	CT mount	CM mount	Foot mounting bracket	U type adapter	G type adapter	
63 [2.480]	9.3 [20.5]	0.0080 [0.0176]	0.2 [0.4]	1.0 [2.2]	2.4 [5.3]	2.6 [5.7]	3.4 [7.5]	0.3 [0.7]	1.7 [3.7]	1.7 [3.7]	
80 [3.150]	16.1 [35.5]	0.0128 [0.0282]	0.6 [1.3]	1.2 [2.6]	4.3 [9.5]	4.9 [10.8]	5.5 [12.1]	0.6 [1.3]	2.9 [6.4]	3.3 [7.3]	

Long piston

Bore size mm [in.]	Zero stroke mass (With long mount)	Additional mass for each 1mm [0.0394in.] stroke	Additional mass of mount for piston mount, mounting bracket, and adapter						kg [lb.]	
			LT mount	CL mount	CLT mount	Foot mounting bracket	U type adapter	G type adapter		
63 [2.480]	13.9 [30.6]	0.0080 [0.0176]	0.7 [1.5]	5.2 [11.5]	5.9 [13.0]	0.3 [0.7]	1.7 [3.7]	1.7 [3.7]		
80 [3.150]	23.2 [51.2]	0.0128 [0.0282]	1.2 [2.6]	8.8 [19.4]	10.0 [22.1]	0.6 [1.3]	2.9 [6.4]	3.3 [7.3]		

SLIT TYPE RODLESS CYLINDERS φ 63, φ 80

Dimensions (mm)

Standard piston, short mount type

ORC ×

Note : The connection port can be located on the bottom. For details, consult us.

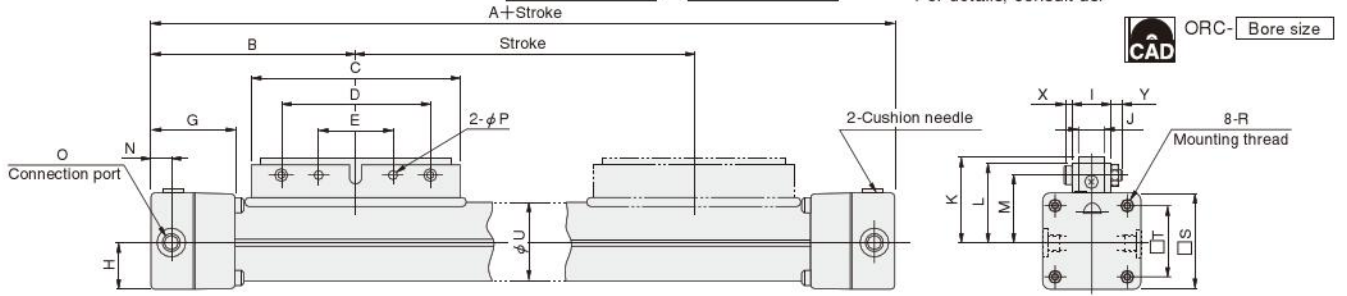

Code	A	B	C	D	E	G	H	I	J	K	L	M	N	O	P	R	S	T	U	X	Y
63 [2.480]	430	215	220	180	90	82	53	30	19	83	78	68	20	4-Rc3/8	9	M8×1.25 Depth20	106	78	88	8	10
80 [3.150]	520	260	280	240	120	102	66	32	20	101	95	83	25	2-Rc1/2	11	M10×1.5 Depth25	132	96	112	10	13

T mount for standard piston

ORC-ST

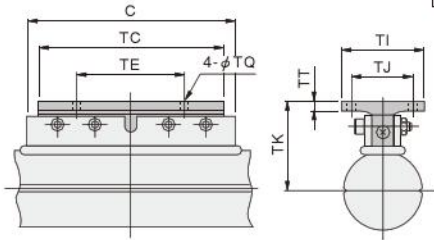

Code	C	TC	TE	TI	TJ	TK	TQ	TT
63 [2.480]	220	208	130	80	60	89	9	7
80 [3.150]	280	268	180	100	75	108	11	8

CT mount for standard piston

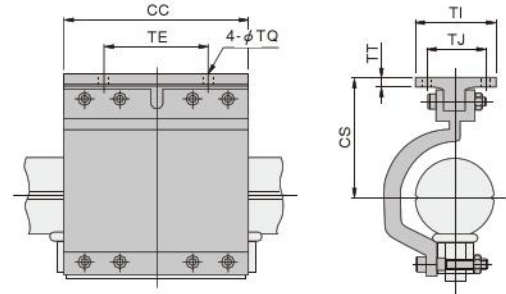

Code	CC	CS	TE	TI	TJ	TQ	TT
63 [2.480]	208	123	130	80	60	9	7
80 [3.150]	268	150	180	100	75	11	8

M mount for standard piston

ORC-SM

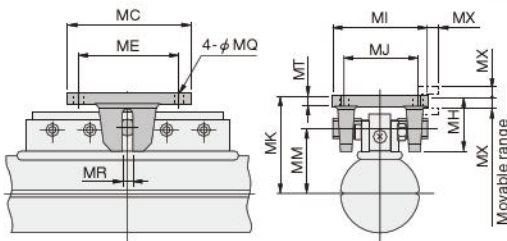

Code	MC	ME	MH	MI	MJ	MK	MM	MQ	MR	MT	MX
63 [2.480]	120	100	48	90	70	100	70	9	10	6	10
80 [3.150]	150	125	60	110	85	122	86	11	13	8	12

CM mount for standard piston

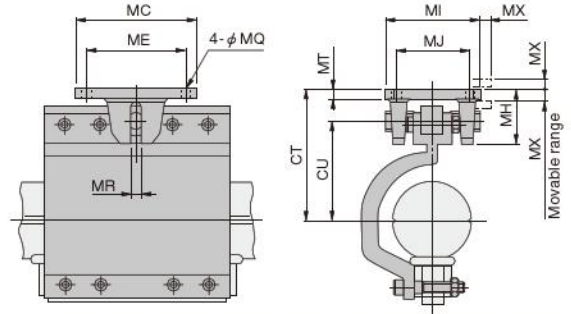

Code	CT	CU	MC	ME	MH	MI	MQ	MR	MT	MX
63 [2.480]	134	104.5	120	100	48	90	9	10	6	10
80 [3.150]	163	128	150	125	60	110	11	13	8	12

C mount for standard piston

ORC-CS

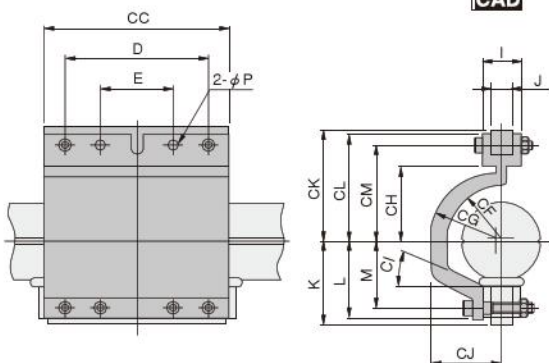

Code	D	E	I	J	K	L	M	P	CC	CF	CG	CH	CI	CJ	CK	CL	CM
63 [2.480]	180	90	30	19	83	78	68	9	208	62	71	82	15°	77	117	112	102
80 [3.150]	240	120	32	20	101	95	83	11	268	78	88	102	15°	96	143	137	125

Long piston, long mount type

Note: The connection port can be located on the bottom.
For details, consult us.

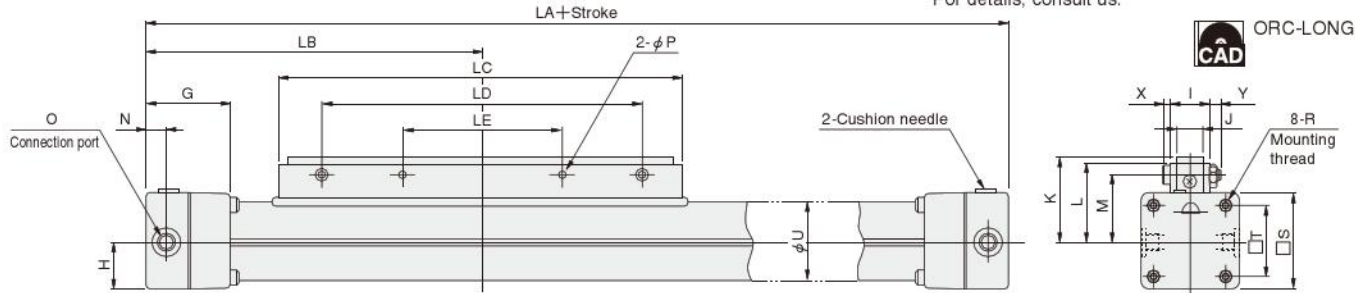

Bore mm [in.]	Code	G	H	I	J	K	L	M	N	O	P	R	S	T	U	X	Y	LA	LB	LC	LD	LE
63 [2.480]		82	53	30	19	83	78	68	20	4-Rc3/8	9	M8 X 1.25 Depth20	106	78	88	8	10	730	365	480	400	200
80 [3.150]		102	66	32	20	101	95	83	25	2-Rc1/2	11	M10 X 1.5 Depth25	132	96	112	10	13	820	410	560	480	240

LT mount for long piston

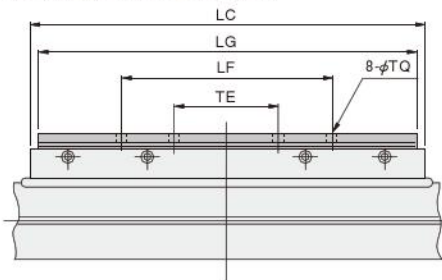

Bore mm [in.]	Code	LC	LF	LG	TE	TI	TJ	TK	TQ	TT
63 [2.480]		480	260	468	130	80	60	89	9	7
80 [3.150]		560	360	548	180	100	75	108	11	8

Foot mounting bracket

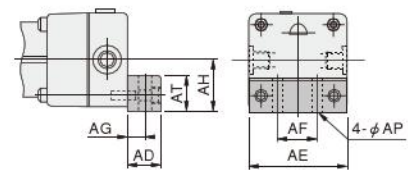

Bore mm [in.]	Code	AD	AE	AF	AG	AH	AP	AT
63 [2.480]		30	104	48	15	57	11	40
80 [3.150]		35	130	60	17.5	72	14	50

CL mount for long piston

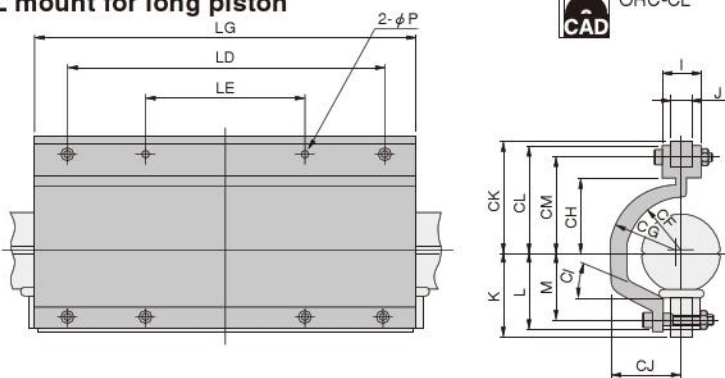

Bore mm [in.]	Code	I	J	K	L	M	P	CF	CG	CH	CI	CJ	CK	CL	CM	LD	LE	LG
63 [2.480]		30	19	83	78	68	9	62	71	82	15°	77	117	112	102	400	200	468
80 [3.150]		32	20	101	95	83	11	78	88	102	15°	96	143	137	125	480	240	548

U type adapter

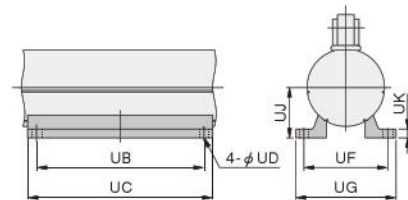

Bore mm [in.]	Code	UB	UC	UD	UF	UG	UJ	UK
63 [2.480]		190	210	11	95	114	57	10
80 [3.150]		235	260	14	120	144	72	12

CLT mount for long piston

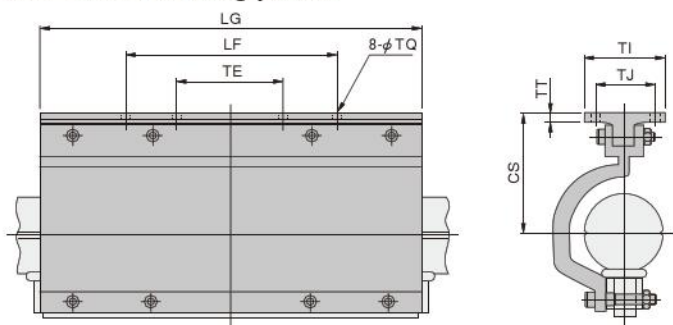

Bore mm [in.]	Code	CS	LF	LG	TE	TI	TJ	TQ	TT
63 [2.480]		123	260	468	130	80	60	9	7
80 [3.150]		150	360	548	180	100	75	11	8

E type adapter (only φ 63)

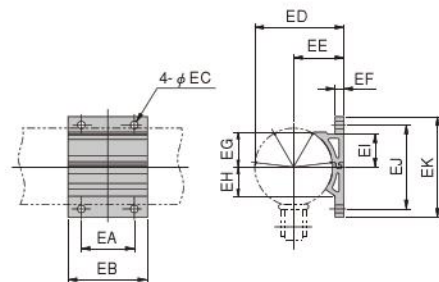

Model	EA	EB	EC	ED	EE	EF	EG	EH	EI	EJ	EK
ORC63	60	90	9	101	57	10	39.5	32.9	37.5	95	114

Dimensions (mm)

G type adapter (only $\phi 80$)

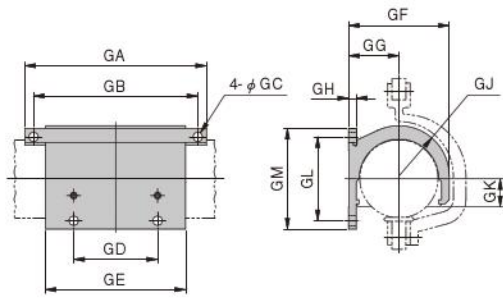

Model	GA	GB	GC	GD	GE	GF	GG	GH	GJ	GK	GL	GM
ORC80	260	235	14	120	200	144	72	12	72	40	120	144

SENSOR SWITCHES

φ 63, φ 80

Since a magnet is already standard equipment on the each size's rodless cylinder, mounting a sensor switch will enable use in sensor switch applications.

Order Codes for Sensor Switch

Without holder.....

With holder..... - **ORC**

Bore size

Holder for rodless cylinder

Lead wire length
A — 1000mm [39in.]
B — 3000mm [118in.]

Sensor switch
For bore sizes φ 63 and φ 80
ZG530 — 2-lead wire Solid state type with indicator lamp
ZG553 — 3-lead wire Solid state type with indicator lamp
CS3M — Reed switch type with indicator lamp
CS4M — Reed switch type with indicator lamp
CS5M — Reed switch type without indicator lamp

Order code for holder only
For φ 63 and φ 80 sensor switch mounting
G5—ORC

Bore size
63 : For φ 63 [2.480in.]
80 : For φ 80 [3.150in.]

DC10~28V
 DC4.5~28V
 DC10~30V
 AC85~115V
 DC10~30V
 AC85~115V
 DC3~30V
 AC85~115V

● For details of sensor switches, see p.1544.

Sensor Switch Operating Range, Response Differential, and Maximum Sensing Location

● Operating range

The distance the piston travels in one direction, while the switch is in the ON position. The center of the operating range is approximately the maximum sensing location.

● Response differential

The distance between the point where the piston turns the switch ON and the point where the switch is turned OFF as the piston travels in the opposite direction.

● Maximum sensing location

Sensor switch model	ZG530, ZG553		CS□M	
	63 [2.480]	80 [3.150]	63 [2.480]	80 [3.150]
Operating range: ℓ	9.2~15.3 [0.362~0.602]	11.7~19.5 [0.461~0.768]	15~29 [0.591~1.142]	21~34 [0.827~1.339]
Response differential: C	1.0 [0.039] or less		3 [0.118]	
Maximum sensing location ^{Note}	11 [0.433]		11 [0.433]	

Note: This is the length measured from the switch's opposite end side to the lead wire.

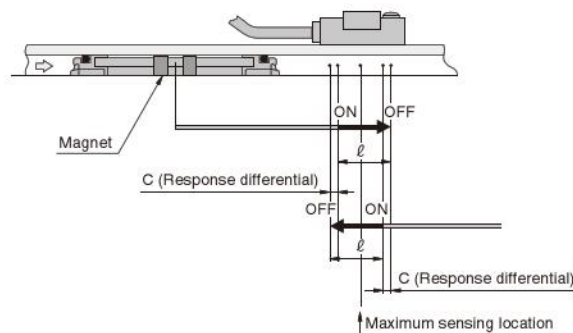

Mounting Location of Sensor Switch

$\phi 63$ [2.480In.], $\phi 80$ [3.150In.]

When the sensor switch is mounted in the locations shown below (the figures in the tables are reference values), the magnet comes to the maximum sensing location of the sensor switch at the end of the stroke.

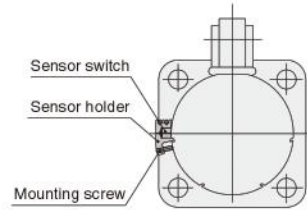
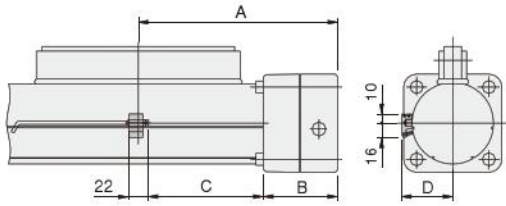

Code Piston specification Bore mm [in.]	A		C		B	D
	Standard piston	Long piston	Standard piston	Long piston		
63 [2.480]	215 [8.46]	365 [14.37]	124 [4.88]	274 [10.79]	80 [3.15]	56 [2.20]
80 [3.150]	260 [10.24]	410 [16.14]	149 [5.87]	299 [11.77]	100 [3.94]	68 [2.68]

- Loosening the sensor holder mounting screw allows the sensor switch to be moved along the switch mounting groove on the cylinder body.
- Tighten the mounting screw with a tightening torque of 0.2N·m [1.8in·lbf].

Handling Instructions and Precautions



Selection and Mounting

Allowable load and moment

Although the rodless cylinder can be used with directly applying loads, make sure that the load and moment do not exceed the values in the table below.

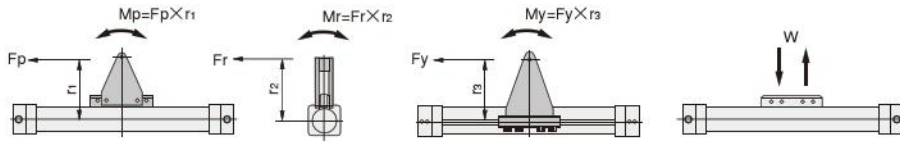

Bore size mm [in.]	Standard piston				Long piston			
	Mp N-m [ft-lbf]	Mr N-m [ft-lbf]	My N-m [ft-lbf]	W N [lbf.]	Mp N-m [ft-lbf]	Mr N-m [ft-lbf]	My N-m [ft-lbf]	W N [lbf.]
63 [2.480]	196 [144.6]	7.8 [5.8]	23.5 [17.3]	1618 [363.7]	441.3 [325.5]	15.7 [11.6]	73.6 [54.3]	1618 [363.7]
80 [3.150]	353 [260.4]	15.7 [11.6]	47.1 [34.7]	2354 [529.2]	706.1 [520.8]	31.4 [23.2]	137.3 [101.3]	2354 [529.2]

Remark: The inclined angle of the piston mount when applying the maximum moment in the rolling direction should be a total of 3 degrees or less for both swing directions.

- Cautions:**
- The moment including the inertial force generated when the load is moved or stopped must not exceed the values in the above table. For the mass and piston speed, see the [Cushioning capacity](#).
 - Rolling moment: Mr should not be applied as much as possible.

Cushioning capacity

While variable cushions are standard equipment on all rodless cylinders, keep the maximum mass and speed within the ranges shown in the graph to the right. If load and speed exceed the ranges, install an external shock absorber, etc., to absorb the shock.

- Cautions:**
- The maximum operating speed of the rodless cylinders is 1500mm/s [59.1in./sec.]. Consult us when exceeding this.
 - The mass shown in the graph is the total mass carried by the rodless cylinder.
 - Adjust cushions according to the piston speed and the mass, and absorb the impacts effectively.

Cushioning stroke mm [in.]

Bore size	Cushioning stroke
63 [2.480]	40 [1.575]
80 [3.150]	44 [1.732]

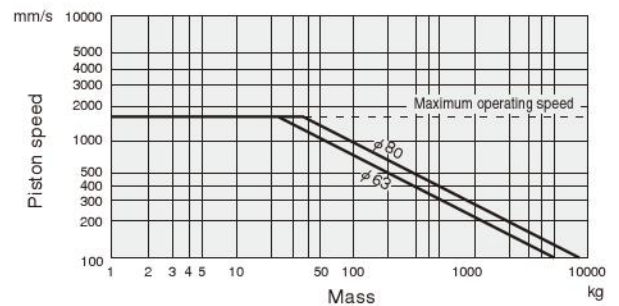

1mm/s = 0.0394in./sec.
1kg = 2.205lb

Adapter

When the stroke is long and the load is large, deflection might be caused on the cylinder barrel. When support span: ℓ exceeds the value in the graph, it should be supported by installing an adapter in the middle. U-type and G-type adapters are available for $\phi 63$ [2.480in.] and $\phi 80$ [3.150in.].

Support span : ℓ mm [in.]

Bore size	Support span : ℓ	
	Standard piston	Long piston
63 [2.480]	Stroke + 430 [16.93]	Stroke + 730 [28.74]
80 [3.150]	Stroke + 520 [20.47]	Stroke + 820 [32.28]

Caution: If the support span exceeds 4000mm [157.48in.] with $\phi 63$ [2.480in.], or 5000mm [196.85in.] with $\phi 80$ [3.150in.], adapters must be installed in the middle regardless of the load.

● $\phi 63, \phi 83$

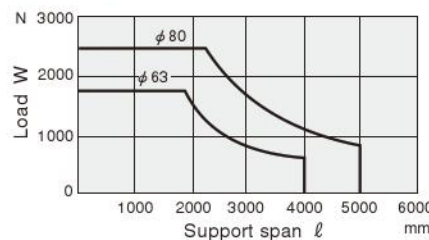

1N = 0.2248lbf.
1mm = 0.0394in.

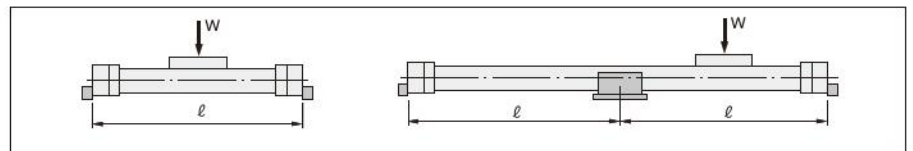

Mounting

- While any mounting direction is allowed, we recommend that the rodless cylinder be installed so that it faces downward when mounting in locations subject to dripping water or oil, etc., or to large amounts of dust.
- Avoid any electric welding after mounting the rodless cylinder. Current may flow into the cylinder, generate sparks between the inner seal band, outer seal band, and cylinder barrel, and damage the seal band.

Caution: Avoid applying strong shocks to the cylinder barrel's slit portion.

Intermediate stop control

Since for structural reasons external air leakage is inevitable for the rodless cylinder, use of all port block 3-position valves, etc., for intermediate stop control could result in failure to maintain the stopping position, and the piston speed could not be controlled when restarting. We recommend, therefore, double-sided pressure control circuits that use PAB-connection 3-position valves, etc. For intermediate stopping control under constant loads, such as vertical mountings, consult us.

Handling Instructions and Precautions



Assembling Instructions

Assembling the piston mount

T mount and LT mount for $\phi 63$ and $\phi 80$

- ① Remove O-ring for holding the scraper and the mount fixing bolt, and detach the short mount which is standard equipment.
- ② Detach the scraper on the short mount and attach it to the T mount or LT mount.
- ③ Secure the T mount or LT mount to the piston yoke with fixing bolts and install scraper holding O-ring.

M mount for $\phi 63$ and $\phi 80$

- ① Remove scraper holding O-ring and the mount fixing bolt, and detach the short mount which is standard equipment.
- ② Detach the scraper on the short mount and reattach it to the M mount.
- ③ Insert the pins into the M mount and assemble onto the piston yoke and secure it with fixing bolts, and install the scraper holding O-ring.
- ④ Align the grooves on the mount plate to the pin, and place the mount on the pin.

C mount, CT mount, CM mount,

CL mount and CLT mount for $\phi 63$ and $\phi 80$

Remove the mount fixing bolts, and install C mount to the piston yoke using C mount fixing bolts (long bolt).

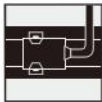

Sensor switch

Handling precautions

1. The sensor switch case is a magnetic shield type, but avoid using it in places with strong external magnetic field and keep it away from strong power lines or currents.
2. Do not apply more than 98N [22lbf.] tensile force on the lead wire.
3. Avoid use in ambient chemical atmospheres.
4. Consult us regarding application in environments subject to dripping water or oil.
5. The ON time of the sensor switch shortens when the piston speed is fast and the sensor switch is installed in the middle of the stroke. Care should be taken because the relay etc. might not be able to follow.
ON time [ms] = (operation range mm [in.] / piston speed mm/s [in./sec.]) $\times 10^3$



Maintenance

The rodless cylinder is structurally incapable of completely preventing air leakage to the outside. Nevertheless, particles adhering to the inner seal band are the most common cause of initial-staged air leakages, and this type of failure is easily remedied.

First, loosen the outer seal band setscrews, remove the outer seal band, and apply approx. 0.1MPa [15psi.] of air pressure to the rodless cylinder. Next, insert a cleaning tool inside the cylinder barrel slit and then, while pressing down the inner seal band and moving it along the slit, use air to blow off the particles.

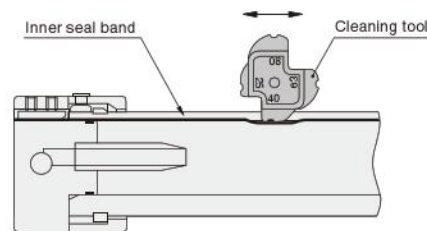

- Cautions:**
1. Always use protective glasses.
 2. When performing maintenance, use the special cleaning tool. Use of a screwdriver or other tool could damage the inner seal band or cylinder barrel.
 3. If the above maintenance fails to stop the air leakage, follow instructions in the user's manual to perform a cylinder overhaul.



General precautions

Piping

Always thoroughly blow off (use compressed air) the tubing before connecting it to the rodless cylinder. Entering chips, sealing tape, rust, etc., generated during piping work could result in air leaks or other defective operation.

Atmosphere

1. If using in locations subject to dripping water, dripping oil, etc., or to large amounts of dust, the band may break or the life of the seals could be shortened. Use a cover to protect the unit or install with the mount facing downward.
2. Do not engage in electric welding close to the rodless cylinder. The welding spatters could damage the outer seal band.
3. The product cannot be used when the media or ambient atmosphere contains any of the substances listed below.
Organic solvents, phosphate ester type hydraulic oil, sulphur dioxide, chlorine gas, or acids, etc.

Lubrication

Though it is possible to use without lubricating oil when the cylinder speed is 500mm/s [19.7in./sec.] or less, it is recommended to use the following lubricating oils when using at a speed of 500mm/s [19.7in./sec.] or more.

Recommended oils

Idemitsu Kosan Co., Ltd. : Daphne Rockdrill 46

Showa Shell Sekiyu K.K. : Rock drill oil 32

Mobil Sekiyu K.K. : Almo 525

Others: Products equivalent to the above

Media

1. Use air for the media. For the use of any other media, consult us.
2. Air used for the rodless cylinder should be clean air that contains no deteriorated compressor oil, etc. Install an air filter (filtration of a minimum 40 μ m) near the rodless cylinder or valve to remove collected liquid or dust. In addition, drain the air filter periodically.