



CAD drawing data catalog
is available.



KOGANEI

ACTUATORS GENERAL CATALOG

SLIT TYPE RODLESS CYLINDERS ϕ 10

CONTENTS

Features/Specifications/Order Codes	1069
Inner Construction	1070
Dimensions	1071
Handling Instructions and Precautions	1072

SLIT TYPE RODLESS CYLINDERS ϕ 10



Caution

Before use, be sure to read the "Safety Precautions" on p. 57.

SLIT TYPE RODLESS CYLINDERS ϕ 10

ORC 10

The smallest slit barrel type with seal band in the series

- Offers directly applying loads, non-rotating, and long strokes in hard-to-reach places not covered under conventional small-bore cylinders.
- Compact sensor switch strongly supports the space savings of the ultra-slender body.

Symbols

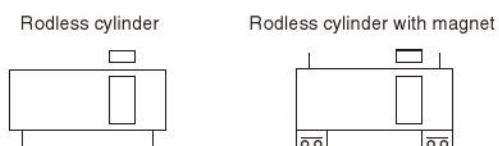

Specifications

Item	Bore mm [in.]	10 [0.394]
Operation type		Double acting type
Media		Air
Operating pressure range MPa [psi.]		0.2~0.7 [29~102]
Proof pressure MPa [psi.]		1.03 [149]
Operating temperature range °C [°F]		0~60 [32~140]
Operating speed range mm/s [in./sec.]		100~500 [3.9~19.7] ^{Note}
Cushion		Rubber bumper
Lubrication		Not required
Maximum stroke mm [in.]		2000 [78.74]
Stroke tolerance mm [in.]	1000 [39.37] or less	+5 [+0.197] 0 [0]
	1001~2000 [39.41~78.74]	+6 [+0.236] 0 [0]
Port size		M5×0.8

Note: For piston speed, see p.1072 Cushioning capacity.

Stroke

mm	
Standard strokes	Available strokes
100, 200, 300, 400, 500	25~2000

Remark: Non-standard strokes are available at 1mm pitch intervals. Consult us for delivery.

Order Codes

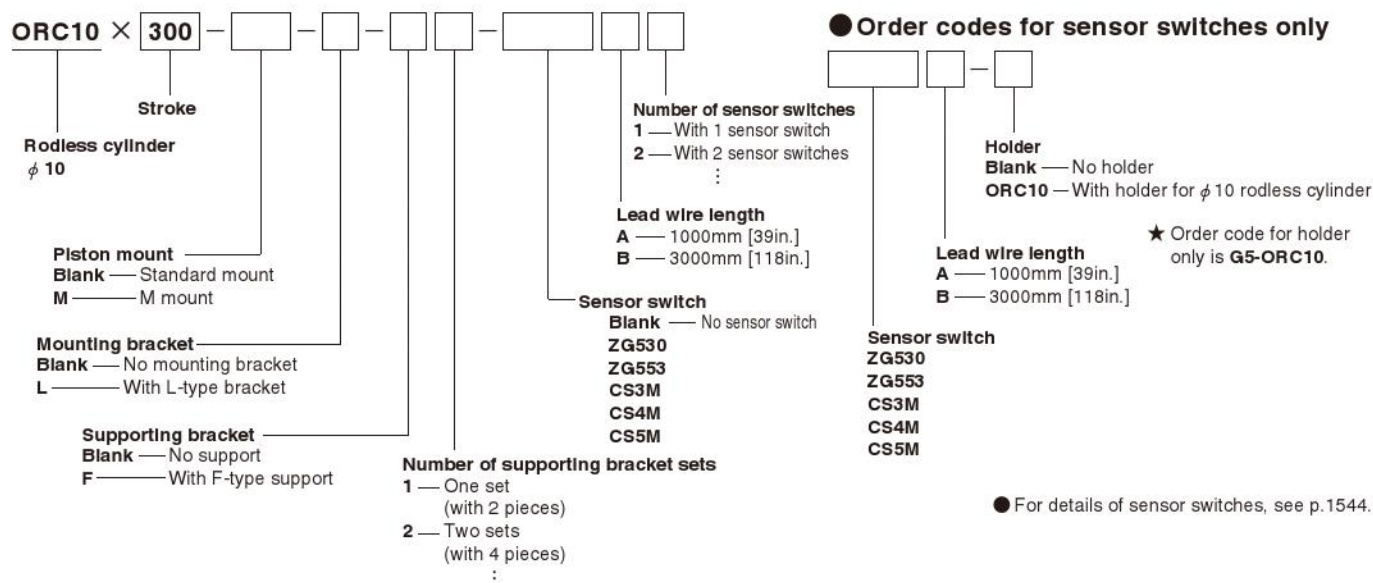

Additional parts

● Order code for L-type bracket only

L- ORC 10

● Order code for F-type bracket only

F- ORC 10

● Order code for M mount only

M- ORC 10

Inner Construction

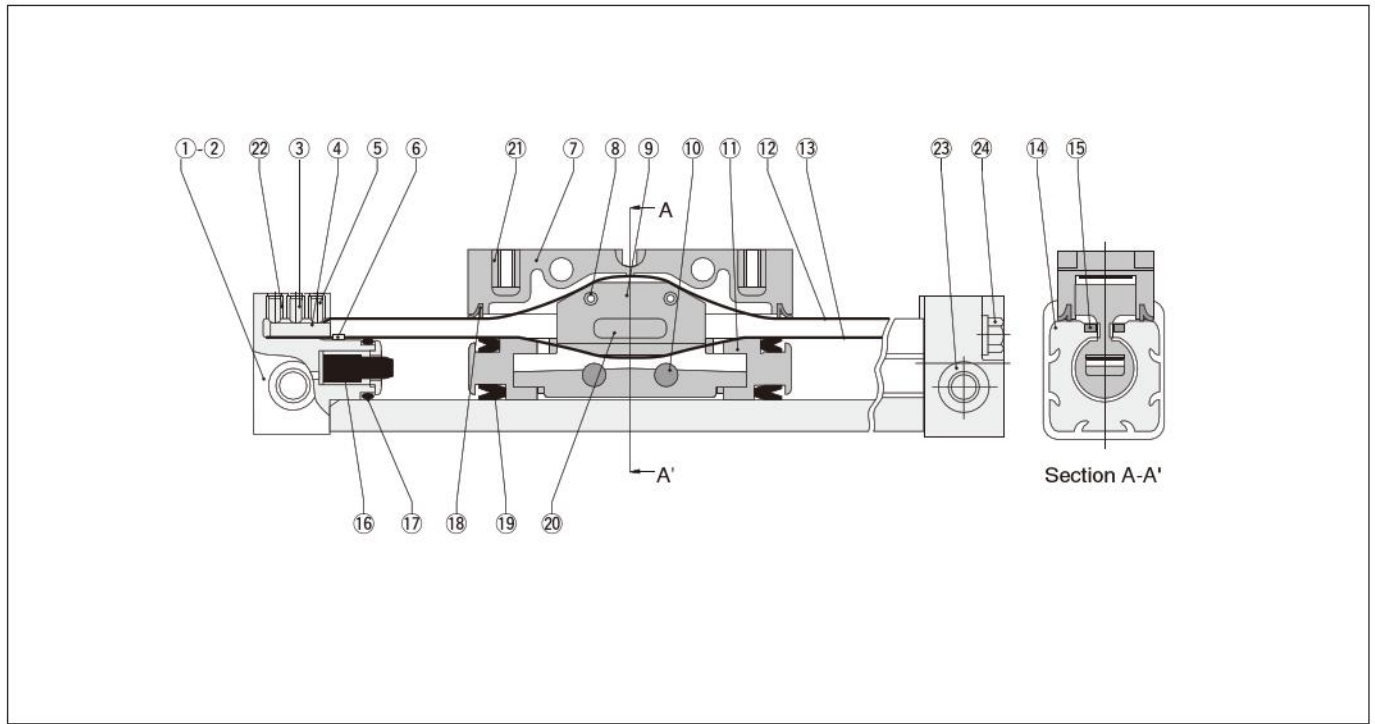

Major Parts and Materials

No.	Parts	Materials	Q'ty	Remarks
①	End cover R ^{Note 1}	Polybutylene terephthalate	1	
②	End cover L ^{Note 2}	Polybutylene terephthalate	1	
③	Inner seal band setscrew	Alloy steel	4	Hexagon socket setscrew
④	Inner seal band lock	Steel	2	Nickel plated
⑤	Outer seal band setscrew	Alloy steel	4	Hexagon socket setscrew
⑥	Rivet	Polyacetal	2	
⑦	Piston mount	Nylon	1	
⑧	Spring pin	Alloy steel	2	
⑨	Piston yoke	Zinc alloy	1	Chromating
⑩	Magnet	Rare earth magnet	2	
⑪	Piston	Polyacetal	2	
⑫	Outer seal band	Stainless chrome steel	1	

Notes: 1. When looking at the front of the connection ports, this is the left sided one.
 2. When looking at the front of the connection ports, this is the right sided one.

No.	Parts	Materials	Q'ty	Remarks
⑬	Inner seal band	Stainless chrome steel	1	
⑭	Cylinder barrel	Aluminum alloy	1	Anodized
⑮	Magnet strip	Rubber magnet	2	
⑯	Bumper	Synthetic rubber (NBR)	2	
⑰★	Cylinder gasket	Synthetic rubber (NBR)	2	
⑱★	Scraper	Nylon	1	
⑲★	Piston seal	Synthetic rubber (NBR)	2	
⑳★	Bearing strip	Polyethylene	2	
㉑	Thread insert	Brass	2	
㉒	Thread insert	Brass	8	
㉓	Thread insert	Brass	2	Nickel plated
㉔	End cap screw	Alloy steel	4	Zinc plated

★: Available as a seal repair kit.

Cylinder Thrust

Select a suitable cylinder bore size considering the load and air pressure to obtain the required thrust.

Since the figures in the table are calculated values, select a bore size that results in a load ratio (load ratio = $\frac{\text{Load}}{\text{Calculated value}}$) of 70% or less.

Pressure area mm ² [in. ²]	Air pressure MPa [psi.]					
	0.2 [29]	0.3 [44]	0.4 [58]	0.5 [73]	0.6 [87]	0.7 [102]
78.5 [0.1217]	15.7 [3.53]	23.5 [5.28]	31.4 [7.06]	39.3 [8.83]	47.1 [10.59]	55.0 [12.36]

Mass

Zero stroke mass (with standard mount)	Additional mass for each 1 mm [0.0394in.] stroke	Additional mass of option (per unit)			
		M mount	L-type bracket	F-type support	Sensor switch (with holder)
0.078 [0.172]	0.00054 [0.00119]	0.018 [0.040]	0.008 [0.018]	0.002 [0.004]	A : 0.05 [0.11] B : 0.09 [0.20]

Dimensions (mm)

● Standard mount ORC 10X Stroke

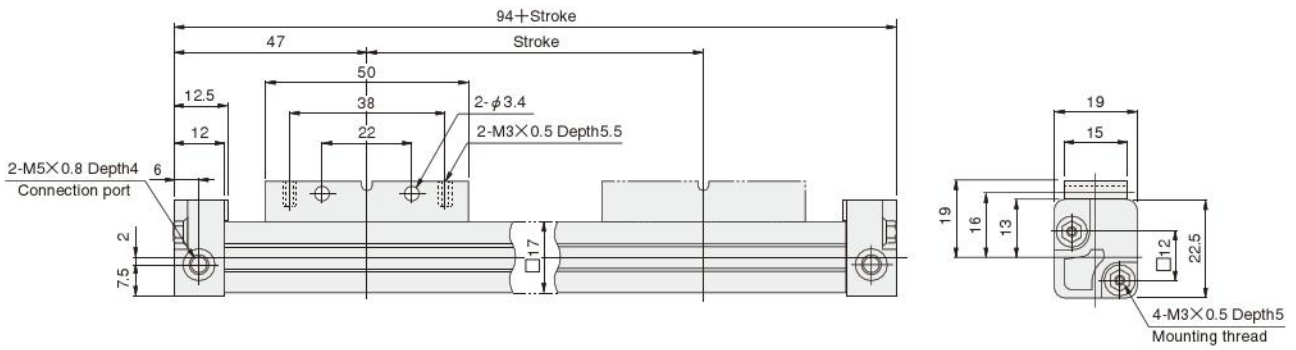

● M mount

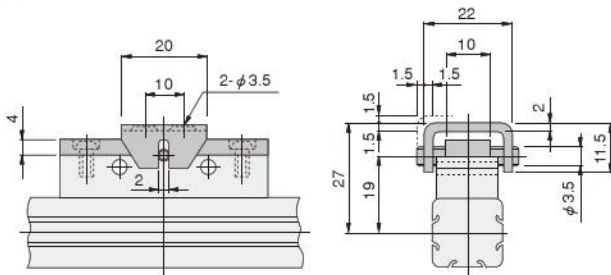

Carrier pin

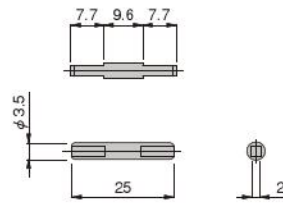

Standard mount viewed from above

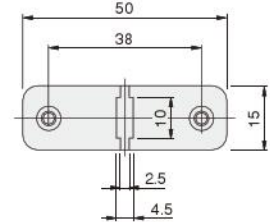

● L-type bracket

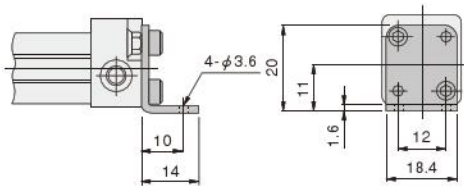

● F-type support

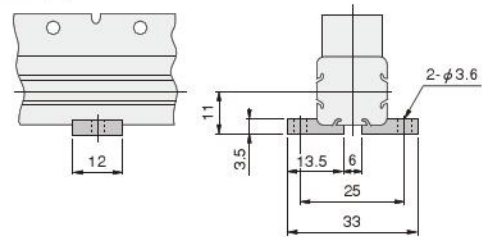

● Mounting location of sensor switch

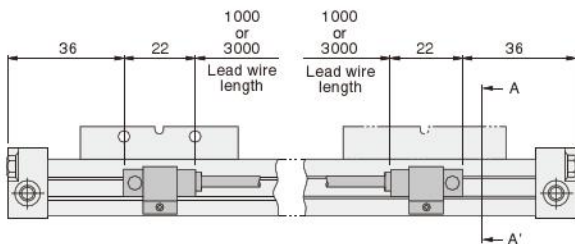

Section A-A' (When sensor switch is mounted.)

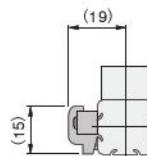

- Notes: 1. When the sensor switch is mounted in the dimensions shown in the drawing, the magnet comes to the sensor switch's maximum sensing location at the end of the stroke.
2. When 2 sensor switches are mounted on the same surface, the minimum stroke should be 25mm.



Sensor Switch Operating Range, Response Differential, and Maximum Sensing Location

● Operating range: ℓ

The distance the piston travels in one direction, while the switch is in the ON position.

● Response differential: C

The distance between the point where the piston turns the switch ON and the point where the switch is turned OFF as the piston travels in the opposite direction.

● Maximum sensing location

	mm	[in.]
Sensor switch model	ZG530, ZG553	CS3M, CS4M, CS5M
Operating range: ℓ	2.4~4.1 [0.094~0.161]	4~7 [0.157~0.276]
Response differential: C	0.7 [0.028]	1 [0.039]
Maximum sensing location ¹⁾²⁾	11 [0.433]	8 [0.315]

Note: This is the length measured from the switch's opposite end side to the lead wire.

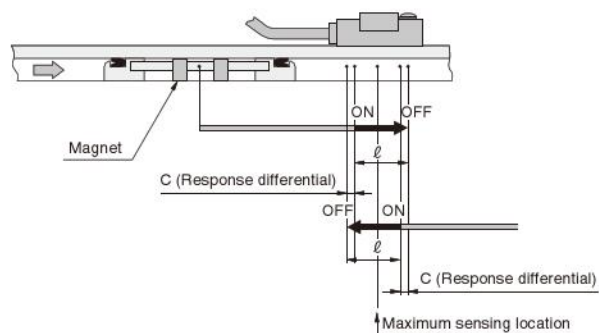

Handling Instructions and Precautions



Selection

Allowable load and moment

Although the rodless cylinder $\phi 10$ [0.394in.] can be used with directly applying loads, make sure that the load and moment do not exceed the values in the below.

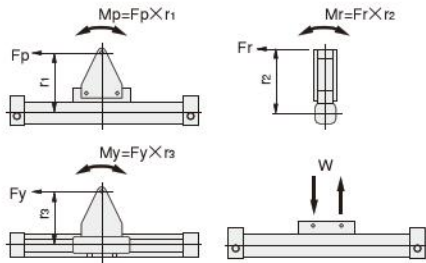

- Pitching moment : $M_p = F_p \times r_1$ 1N·m [0.74ft·lbf]
- Rolling moment : $M_r = F_r \times r_2$ 0.2N·m [0.15ft·lbf]
- Yawing moment : $M_y = F_y \times r_3$ 0.3N·m [0.22ft·lbf]
- Maximum load capacity : W 20N [4.5lbf.]

Remark: The inclined angle of the piston mount when applying the maximum moment in the rolling direction should be 3 degrees or less for totaling both swing directions.

- Cautions:**
- The moment including the inertial force generated when the load is moved or stopped must not exceed the values in the above. For the mass and piston speed, see the **Cushioning capacity**.
 - Rolling moment: M_r Should not be applied as much as possible.

Cushioning capacity

While rubber bumpers are standard equipment on all rodless cylinders $\phi 10$, keep the maximum mass and speed within the ranges shown in the graph below. If load and speed exceed the ranges, install an external shock absorber, etc., to absorb the shock.

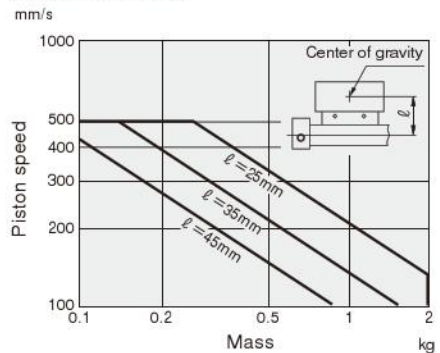

- Cautions:**
- The maximum speed of the rodless cylinder $\phi 10$ [0.394in.] is 500mm/s [19.7in./sec.].
 - The mass shown in the graph is the total mass carried by the rodless cylinder $\phi 10$ [0.394in.].

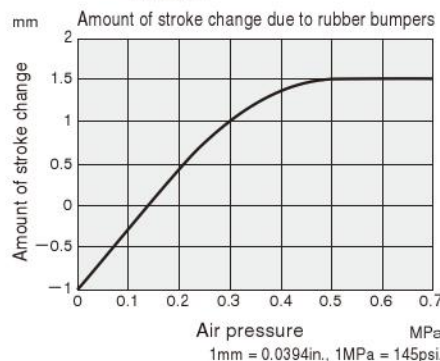

Mounting, Maintenance

Mounting

- While any mounting direction is allowed, we recommend that the piston mount be installed so that it faces downward when mounting in locations subject to dripping water or oil, etc., or to large amounts of dust.
- Avoid any electric welding after mounting the rodless cylinder $\phi 10$ [0.394in.]. Current may flow into the cylinder, generate sparks between the inner seal band, outer seal band, and cylinder barrel, and damage the seal band.

Caution: Avoid applying strong shocks to the cylinder barrel's slit portion.

Support

A long stroke and large load may cause deflection in the cylinder barrel.

If support span: l exceeds the values shown in the graph, install an F-type support in the intermediate stroke position.

Support span: $l = \text{Stroke} + 94\text{mm}$ [3.70in.]

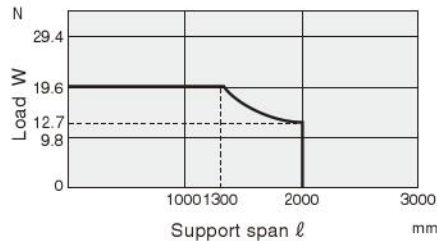

Conversion factors: $1\text{N} = 0.2248\text{lbf.}$, $1\text{mm} = 0.0394\text{in.}$

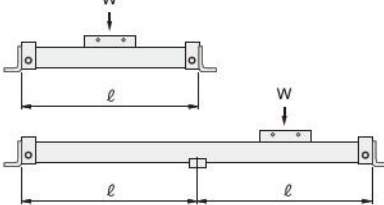

Caution: We recommend mounting an F-type support whenever support span: l exceeds 1300mm [51.18in.], regardless of the load status.

Piston mount assembly

M mount

Set the pin with the collar attached to the standard mount, then use mounting bolts to secure the M mount in place, and align the groove on the mounting plate to the pin, and place the mount on the pin.

Intermediate stop control

Since for structural reasons external air leakage is inevitable for the rodless cylinder $\phi 10$ [0.394in.], use of all port block 3-position valves, etc., for intermediate stop control could result in failure to maintain the stopping position. We recommend, therefore, the installation of double-sided pressure control circuits that use PAB-connection 3-position valves, etc. For intermediate stop control circuit under constant loads, such as vertical mounting applications, consult us.

Maintenance

The rodless cylinder $\phi 10$ [0.394in.] is structurally incapable of completely preventing air leakage to the outside. Nevertheless, particles adhering to the inner seal band are the most common cause of initial-staged air leakages, and this type of failure is easily remedied.

First, loosen the outer seal band setscrews, remove the outer seal band, and apply approx. 0.1MPa [15psi.] of air pressure to the rodless cylinder. Next, insert a cleaning tool inside the cylinder barrel slit and then, while pressing down the inner seal band and moving it along the slit, use air to blow off the particles.

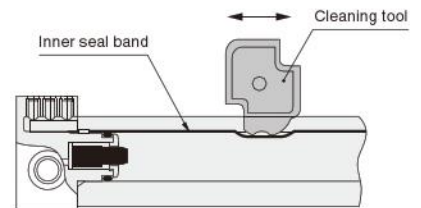

- Cautions:**
- Always use protective glasses.
 - When performing maintenance, use the special cleaning tool. Use of a screwdriver or other tool could damage the inner seal band or cylinder barrel.
 - If the above maintenance fails to stop the air leakage, follow instructions in the user's manual to perform a cylinder overhaul.

Handling Instructions and Precautions



Sensor switch

Handling precautions

1. Because of a magnetic sensing-type sensor switch, avoid use in locations under strong magnetic fields, or near power lines and other large current sources.
2. Do not apply strong force or excessive bending to the lead wire.
3. Avoid use in ambient chemical atmospheres.
4. For use in ambient atmospheres subject to dripping water or oil, consult us.
5. Note that the relay may be unable to respond when the piston speed is high and the switch's ON time becomes too short.

Mounting

Loosening the sensor switch mounting screw (M3) allows removal of the holder and sensor switch.

For mounting, hook the holder latch along with the sensor switch onto the lower groove of the cylinder barrel, and then tighten the mounting screw.

Set the tightening torque of the mounting screw to 0.2N·m [1.8in·lbf].

The sensor switch can be mounted in either location (A) or (B) shown in the diagram. It cannot be mounted in location (C).

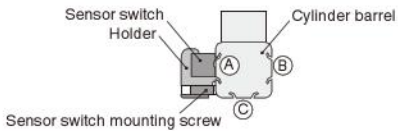

Caution: After mounting the sensor switch, always confirm it is securely mounted.



General precautions

Piping

Always thoroughly blow off (use compressed air) the tubing before connecting it to the rodless cylinder $\phi 10$ [0.394in.]. Entering chips, sealing tape, rust, etc., generated during piping work could result in air leaks or other defective operation.

Atmosphere

1. If using in locations subject to dripping water, dripping oil, etc., or to large amounts of dust, the band may break or the life of the seals could be shortened, and use a cover to protect the unit, or install with the piston mount facing downward.
2. Do not engage in electric welding close to the rodless cylinder $\phi 10$ [0.394in.]. The welding spatters could damage the outer seal band.
3. The product cannot be used when the media or ambient atmosphere contains any of the substances listed below.
Organic solvents, phosphate ester type hydraulic oil, sulphur dioxide, chlorine gas, or acids, etc.

Lubrication

The rodless cylinder $\phi 10$ [0.394in.] can be used without lubrication. If lubrication is required, use the recommended oils listed below.

Recommended oils

Idemitsu Kosan Co., Ltd. : Daphne Rockdrill 46

Showa Shell Sekiyu K.K. : Rock drill oil 32

Mobil Sekiyu K.K. : Almo 525

Others: Products equivalent to the above

Media

1. Use air for the media. For the use of any other media, consult us.
2. Air used for the rodless cylinder $\phi 10$ [0.394in.] should be clean air that contains no deteriorated compressor oil, etc. Install an air filter (filtration of a minimum 40 μm) near the cylinder or valve to remove collected liquid or dust. In addition, drain the air filter periodically.