

# AIR HANDS SERIES

## Full Line-up



Page 1399

### Parallel Type Linear Guide Specification NHC1 Series

- **40% lighter:** Now about 40% lighter than the previous NHB series linear guide specification.
- **45% more compact:** Reduced the width, length, and height.
- **Strong:** Use of high-rigidity linear guide achieves repeatability of  $\pm 0.01\text{mm}$  [ $\pm 0.0004\text{in.}$ ] or less. Centering accuracy is also  $\pm 0.07\text{mm}$  [ $\pm 0.0028\text{in.}$ ] or less.



Page 1403

### Parallel Type Linear Guide Specification

- Lever portion uses a linear guide for long operating life, high precision, long lever travel gripping, and overhang gripping.
- Gripping position repeatability  $\pm 0.01\text{mm}$  [ $\pm 0.0004\text{in.}$ ]. Centering accuracy is also  $\pm 0.07\text{mm}$  [ $\pm 0.0028\text{in.}$ ].
- Magnet for sensor switch is standard equipment.



Page 1407

### Parallel Type Linear Guide Specification Long Stroke

- Open/closed stroke is about double the previous model.
- Gripping position repeatability is  $\pm 0.01\text{mm}$  [ $\pm 0.0004\text{in.}$ ].



Page 1411

### Parallel Type Linear Guide Specification with Fingers

- Fingers attachment is simple to install.
- Gripping position repeatability is  $\pm 0.01\text{mm}$  [ $\pm 0.0004\text{in.}$ ].



Page 1415

## Parallel Type Linear Guide Specification with Rubber Cover

- Dust protection cover is standard equipment.
- Lever portion uses a linear guide for long operating life, high precision, long lever travel gripping, and overhang gripping.
- Gripping position repeatability  $\pm 0.01$  mm [ $\pm 0.0004$ in.].
- Magnet for sensor switch is standard equipment.



Page 1419

## Parallel Type Linear Guide Specification for Clean Systems

- Clean rating corresponds to Class 4 (during suction).
- Gripping position repeatability is  $\pm 0.01$  mm [ $\pm 0.0004$ in.].



Page 1423

## Three-finger Type Linear Guide Specification

- Linear guides are used on three-finger hand! Superior load and moment resistance.  
Centering accuracy is  $\pm 0.05$ mm [ $\pm 0.0020$ in.] or less.  
Gripping position repeatability is  $\pm 0.01$  mm [ $\pm 0.0004$ in.] or less.
- Body is equipped with a hollow space. Convenient for installing a cylinder for workpiece release, etc.



Page 1426

## Parallel Type Cross Roller Bearing Specification

- Lever portion uses cross roller bearings for long operating life and high precision.
- Gripping position repeatability  $\pm 0.01$  mm [ $\pm 0.0004$ in.].
- Dust protection cover is optional.
- Magnet for sensor switch is standard equipment.



Page 1430

## Parallel Type Plain Bearing Specification

- Lever portion uses a slide plate for long operating life.
- Magnet for sensor switch is standard equipment.
- 3-way direct mounting.



Page 1434

## Swing Type

- Lever uses chrome molybdenum steel, with quench hardened major parts, to achieve long operating life.
- Magnet for sensor switch is standard equipment.
- 3-way direct mounting.



Page 1439

## Swing Type High Precision, 180° Open Specification

- Uses a thrust bearing in the lever support area to achieve high precision, high rigidity, and long operating life.
- Uses a link mechanism for compact, high gripping force. Open-close up to 180°.



Page 1443

## Swing Type 180° Open Specification

- Lever uses chrome molybdenum steel, with quench hardened major parts, to achieve long operating life.
- Open/close angle 180°, to allow gripping and releasing of workpieces without retracting a hand body.
- Magnet for sensor switch is standard equipment.
- 3-way direct mounting.

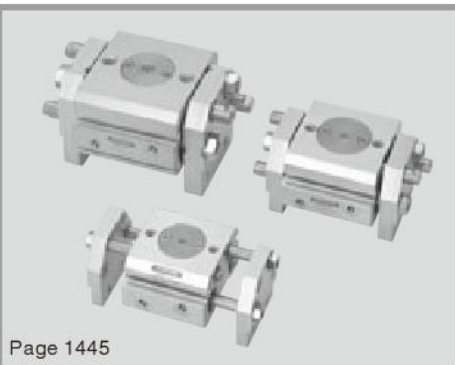

Page 1445

## Rack Operation Parallel Type

- Four types of lever with open/close travel strokes, at 24, 32, 40, and 50mm [0.945, 1.260, 1.575, 1.969in.].
- Magnet for sensor switch is standard equipment.

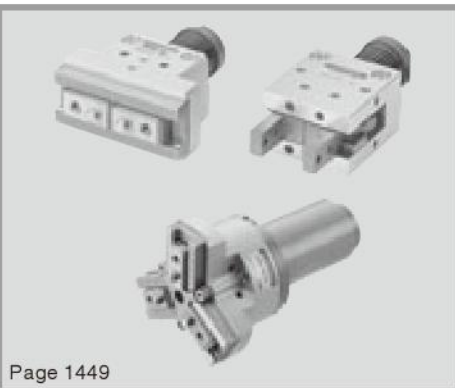

Page 1449

## Mechanical Hands

- Because these do not require air piping, these are optimum for locations where air piping cannot reach (such as on index table, etc.).
- Three types available, including parallel type, parallel type linear guide specification, and linear guide specification three-finger type.
- Spring force can be set to strong or weak in response to the workpiece.
- The linear guide specification uses a linear guide on the lever, to achieve high precision ( $\pm 0.01\text{mm}$  [ $\pm 0.0004\text{in.}$ ]) and long operating life.

# Handling Instructions and Precautions



**Selection**

**Effective gripping force**

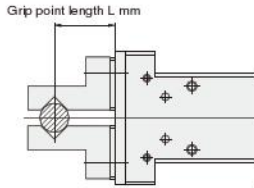

--- : Open side  
— : Closed side

**● Parallel type Linear guide specification (with rubber cover)**

**● Linear guide specification Long stroke**

**● Linear guide specification for clean systems**

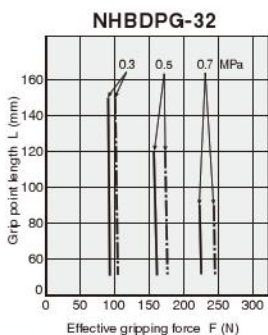
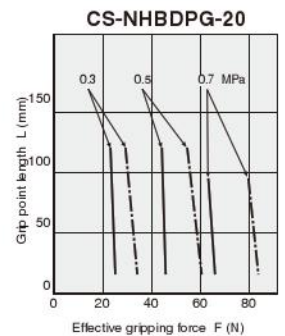
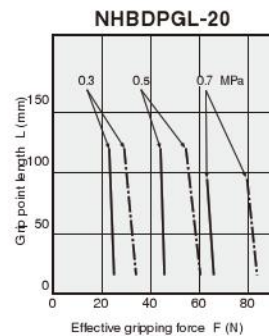
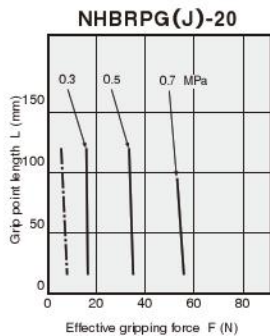
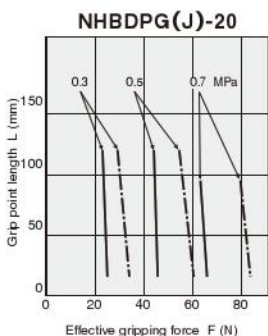
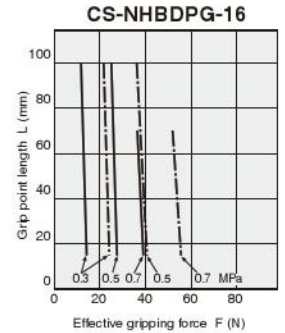
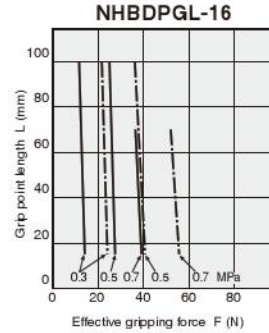
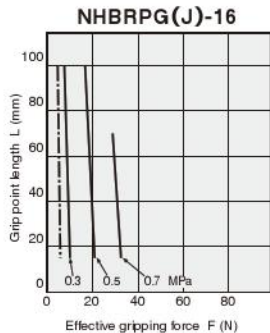
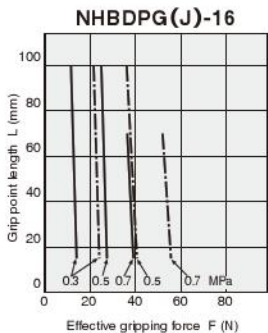
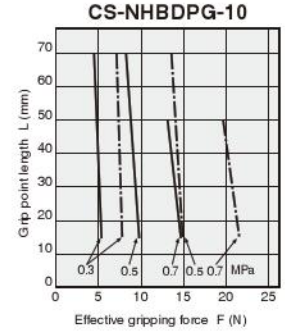
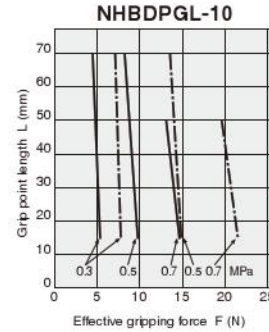
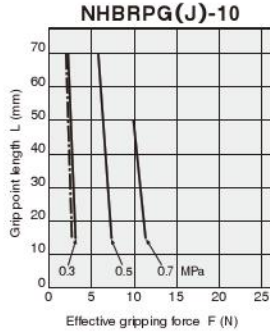
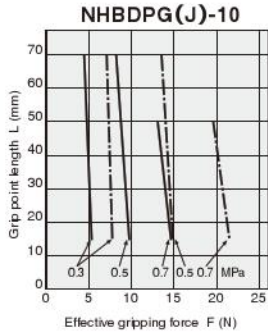
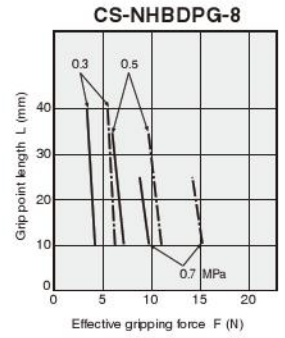
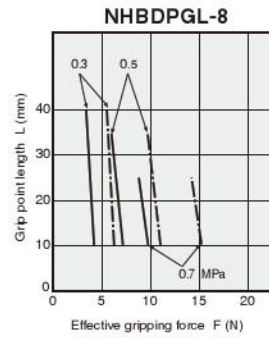
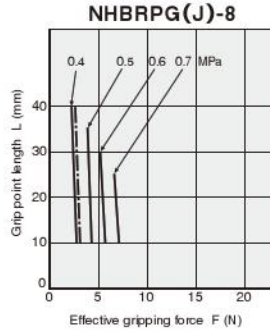
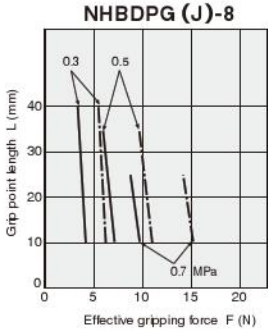

1mm = 0.0394in.  
1N = 0.2248lbf.  
1MPa = 145psi.

1mm = 0.0394in.  
1N = 0.2248lbf.  
1MPa = 145psi.

1mm = 0.0394in.  
1N = 0.2248lbf.  
1MPa = 145psi.

# Handling Instructions and Precautions

## Effective gripping force

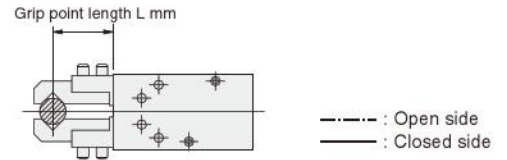
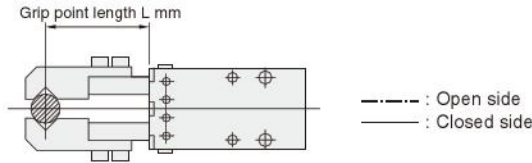

### ● Parallel type Cross roller bearing specification

#### NHBDPA-6

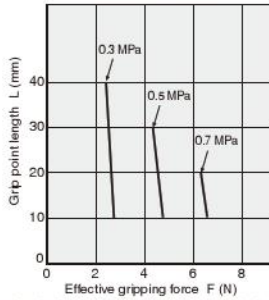

#### NHBRPA-6

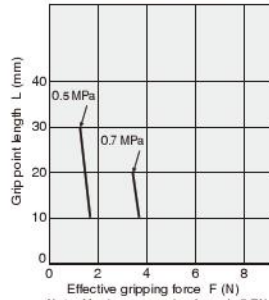

Note: Opening force is equal to or greater than closing force.

Note: Maximum opening force is 2.7N.

#### NHBDPA-10

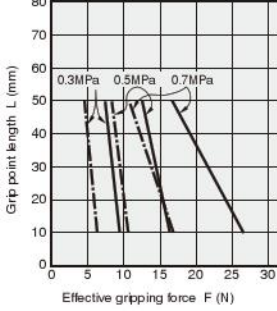

#### NHBRPA-10

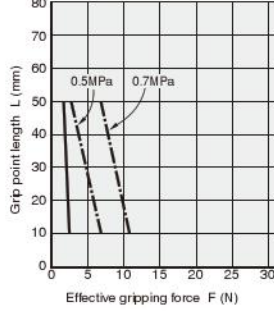

#### NHBDPA-16

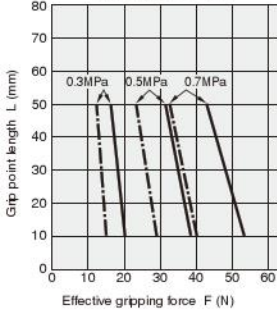

#### NHBRPA-16

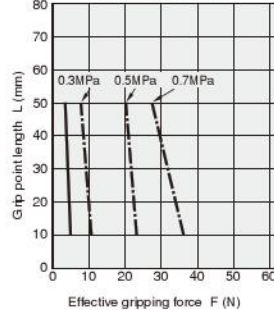

#### NHBDPA-20

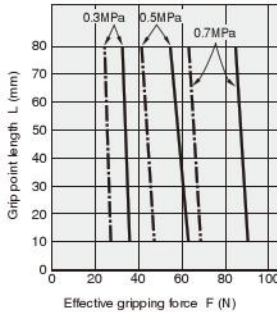

#### NHBRPA-20

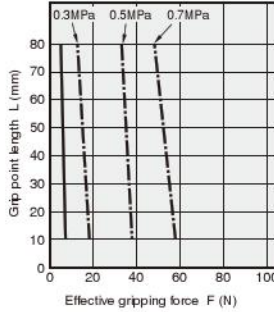

#### NHBDPA-25

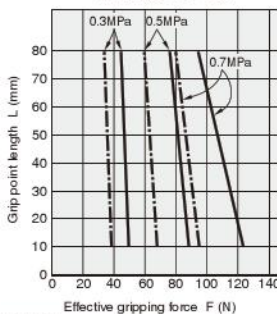

#### NHBRPA-25

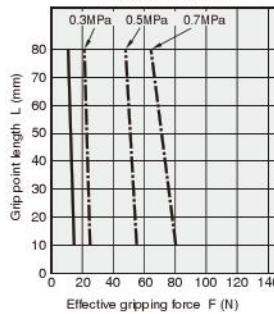

### ● Parallel type Plain bearing specification

#### NHBDP-10

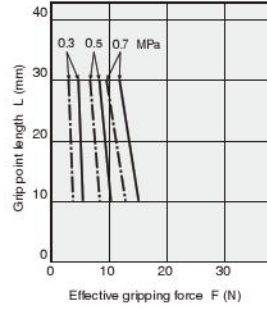

#### NHBRP-10

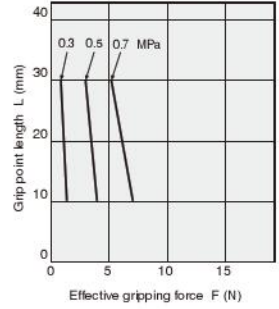

#### NHBDP-16

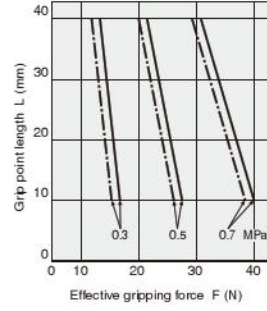

#### NHBRP-16

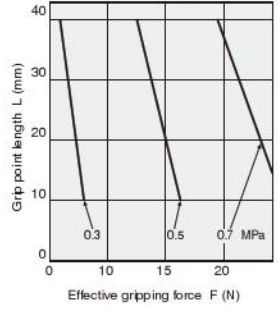

#### NHBDP-20

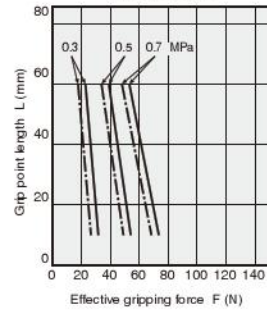

#### NHBRP-20

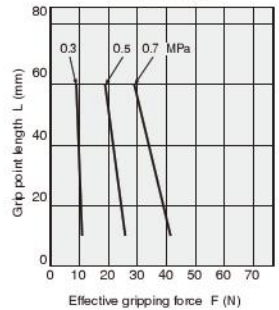

#### NHBDP-25

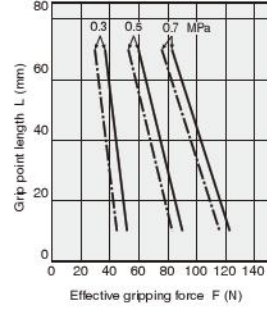

#### NHBRP-25

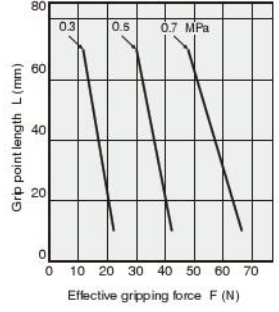

1mm = 0.0394in.  
1N = 0.2248lbf.  
1MPa = 145psi.

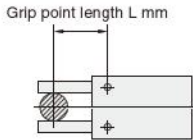

--- : Open side  
 — : Closed side

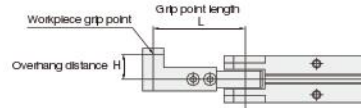

● **Swing type**

● **Swing type**  
**High precision, 180° open specification**

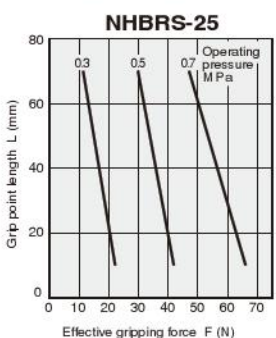
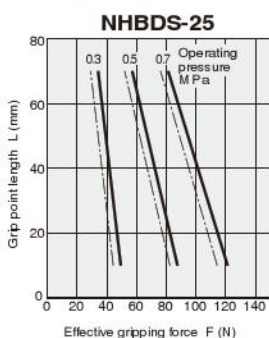
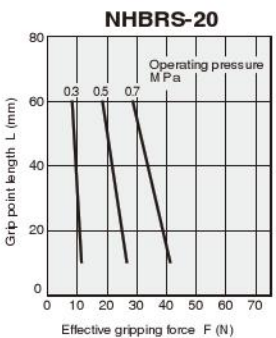
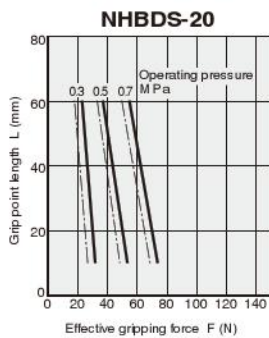
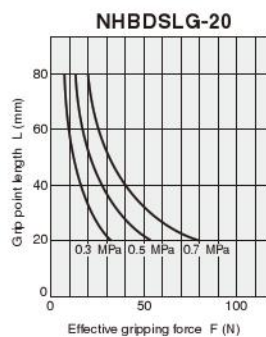
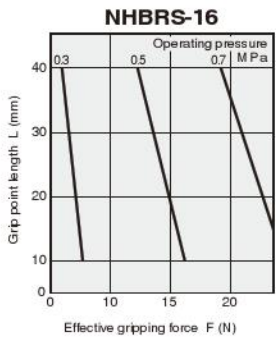
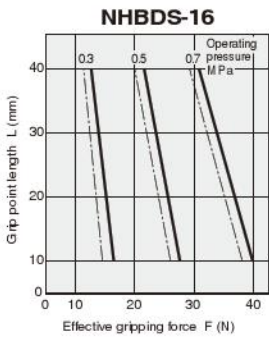
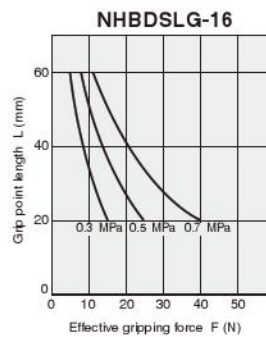
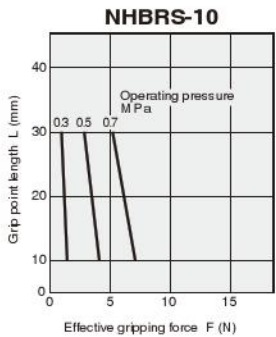
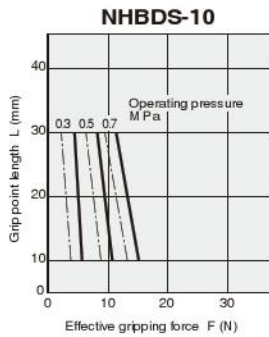
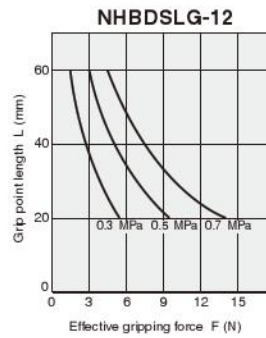
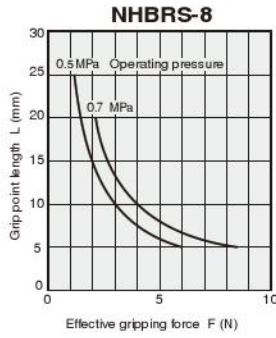
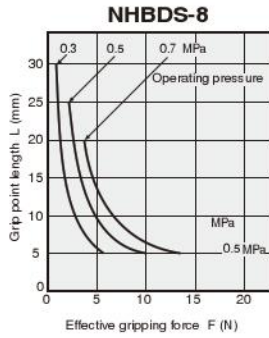

Note: Graphs show the force of closing direction.

1mm = 0.0394in.  
 1N = 0.22481bf.  
 1MPa = 145psi.

# NHB SERIES PARALLEL TYPE

Plain Bearing Specification  
Double Acting Type,  
Single Acting Normally Open Type

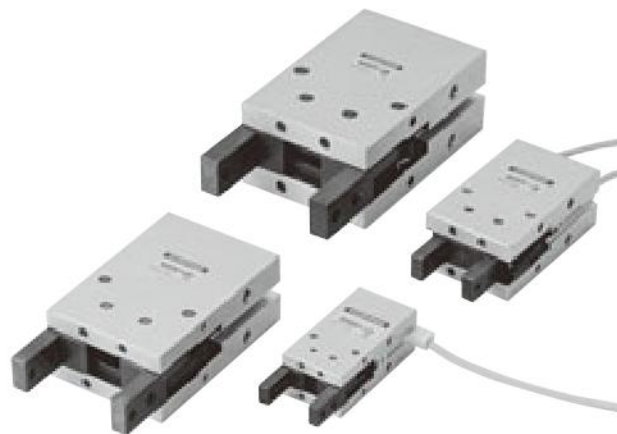

## Symbols

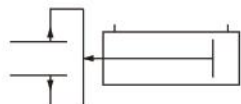

Double Acting Type

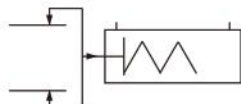

Single Acting  
Normally Open Type

## Specifications

### ● Double acting parallel type

Basic model		NHBDP-10	NHBDP-16	NHBDP-20	NHBDP-25
Item					
Cylinder bore size	mm [in.]	10 [0.394]	16 [0.630]	20 [0.787]	25 [0.984]
Operation type		Double acting type			
Media		Air			
Operating pressure range	MPa [psi.]	0.15~0.7 [22~102]	0.1~0.7 [15~102]		
Proof pressure	MPa [psi.]	1.05 [152]			
Operating temperature range	°C [°F]	0~60 [32~140]			
Maximum operating frequency	cycle/min	180			
Lubrication	Cylinder portion	Not required			
	Lever portion	Required (Apply grease to the sliding portion)			
Maximum grip point length	mm [in.]	30 [1.18]	40 [1.57]	60 [2.36]	70 [2.76]
Gripping force <sup>Note 1</sup> N [lbf.]	Closed side	7.8 [1.75]	23.5 [5.28]	46.1 [10.36]	76.5 [17.20]
	Open side	4.9 [1.10]	17.7 [3.98]	34.3 [7.71]	58.8 [13.22]
Lever open/closed stroke	mm [in.]	4 [0.157]	8 [0.315]	12 [0.472]	14 [0.551]
Port size		M3×0.5		M5×0.8	
Mass <sup>Note 2</sup>	g [oz.]	47 [1.66] (58 [2.05])	120 [4.23] (139 [4.90])	230 [8.11] (256 [9.03])	388 [13.69] (439 [15.49])

Notes: 1. Values are obtained when grip point length is 30mm [1.18in.] under operating pressure 0.5 MPa [73psi.]. For details of the effective gripping force, see the graphs on p.1387.

2. ( ) mean the mass with the mounting bracket: -M.

### ● Single acting normally open parallel type

Basic model		NHBRP-10	NHBRP-16	NHBRP-20	NHBRP-25
Item					
Cylinder bore size	mm [in.]	10 [0.394]	16 [0.630]	20 [0.787]	25 [0.984]
Operation type		Single acting normally open type			
Media		Air			
Operating pressure range	MPa [psi.]	0.35~0.7 [51~102]	0.25~0.7 [36~102]		
Proof pressure	MPa [psi.]	1.05 [152]			
Operating temperature range	°C [°F]	0~60 [32~140]			
Maximum operating frequency	cycle/min	180			
Lubrication	Cylinder portion	Not required			
	Lever portion	Required (Apply grease to the sliding portion)			
Maximum grip point length	mm [in.]	30 [1.18]	40 [1.57]	60 [2.36]	70 [2.76]
Gripping force <sup>Note 1</sup> N [lbf.]	Closed side	2.9 [0.65]	12.7 [2.85]	22.6 [5.08]	37.3 [8.39]
	Open side	2.0 [0.45]	3.9 [0.88]	6.9 [1.55]	13.7 [3.08]
Lever open/closed stroke	mm [in.]	4 [0.157]	8 [0.315]	12 [0.472]	14 [0.551]
Port size		M3×0.5		M5×0.8	
Mass <sup>Note 2</sup>	g [oz.]	48 [1.69] (59 [2.08])	121 [4.27] (140 [4.94])	232 [8.18] (258 [9.10])	392 [13.83] (443 [15.63])

Notes: 1. Values are obtained when grip point length is 30mm [1.18in.] under operating pressure 0.5 MPa [73psi.]. For details of the effective gripping force, see the graphs on p.1387.

2. ( ) mean the mass with the mounting bracket: -M.

## Inner Construction

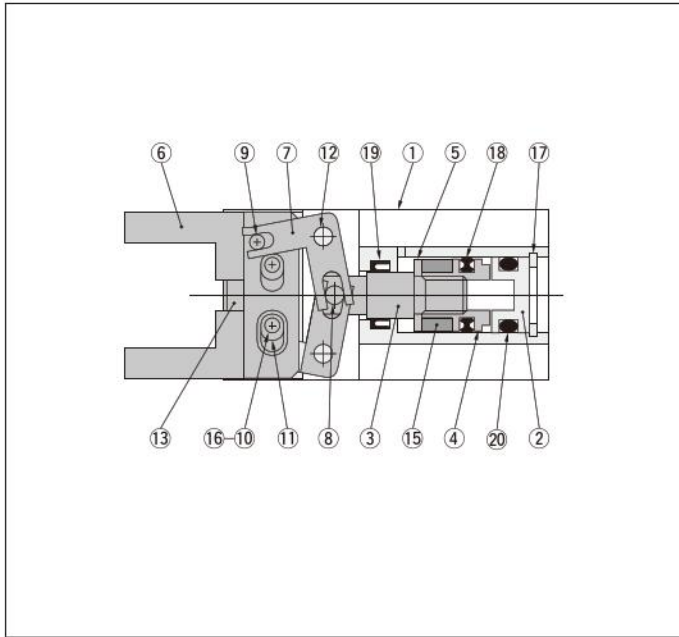





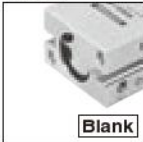

Note: Diagram shows the double acting type with the levers completely opened.

## Major Parts and Materials

No.	Parts	Materials	Remarks
①	Body	Aluminum alloy	
②	Head cover	Aluminum alloy	
③	Piston rod	Stainless steel	
④	Piston	Aluminum alloy	
⑤	Magnet holder	Aluminum alloy	
⑥	Slide lever	Carbon steel	
⑦	Action lever	Carbon steel	
⑧	Rod pin	Carbon steel	
⑨	Slide pin	Carbon steel	
⑩	Slide guide pin	Carbon steel	
⑪	Ring	Carbon steel	
⑫	Fulcrum pin	Carbon steel	
⑬	Slide plate	Carbon steel	
⑭	Spring	Spring steel	Single acting type only
⑮	Magnet	Magnet material	
⑯	Hexagon socket setscrew	Mild steel	
⑰	C-shaped snap ring	Steel	
⑱	Piston seal	Synthetic rubber (NBR)	
⑲	Rod seal	Synthetic rubber (NBR)	
⑳	O-ring	Synthetic rubber (NBR)	

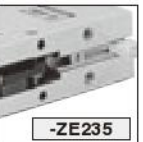
## Order Codes

	Mounting bracket		Sensor switch					Lead wire length	Number of sensor switches (for air hands with sensor switches)
	No mounting bracket	With mounting bracket	No sensor switch	With ZE135	With ZE155	With ZE235	With ZE255		
	 Blank	 -M	 Blank	 -ZE135	 -ZE155	 -ZE235	 -ZE255	A : 1000mm [39in.] B : 3000mm [118in.]	● 1 : With 1 sensor switch ● 2 : With 2 sensor switches ★ Included at shipping
	★ Included at shipping		<ul style="list-style-type: none"> <li>● Solid state type</li> <li>● With indicator lamp</li> <li>● DC10~28V</li> <li>● 2-lead wire</li> <li>● Horizontal lead wire</li> </ul>						
	Basic model	Cylinder bore size							
Double acting type	NHBDP	-10 -16 -20 -25	-M	-ZE135 -ZE155 -ZE235 -ZE255	A B	1 2			
Single acting normally open type	NHBRP	-10 -16 -20 -25	-M	-ZE135 -ZE155 -ZE235 -ZE255	A B	1 2			

### Additional Parts (To be ordered separately)

Mounting bracket



- For φ 10 [0.394in.]  
— NHB-M10
- For φ 16 [0.630in.]  
— NHB-M16
- For φ 20 [0.787in.]  
— NHB-M20
- For φ 25 [0.984in.]  
— NHB-M25

# Dimensions of Parallel Type Plain Bearing Specification (mm)

NHBDP-10  
NHBRP-10

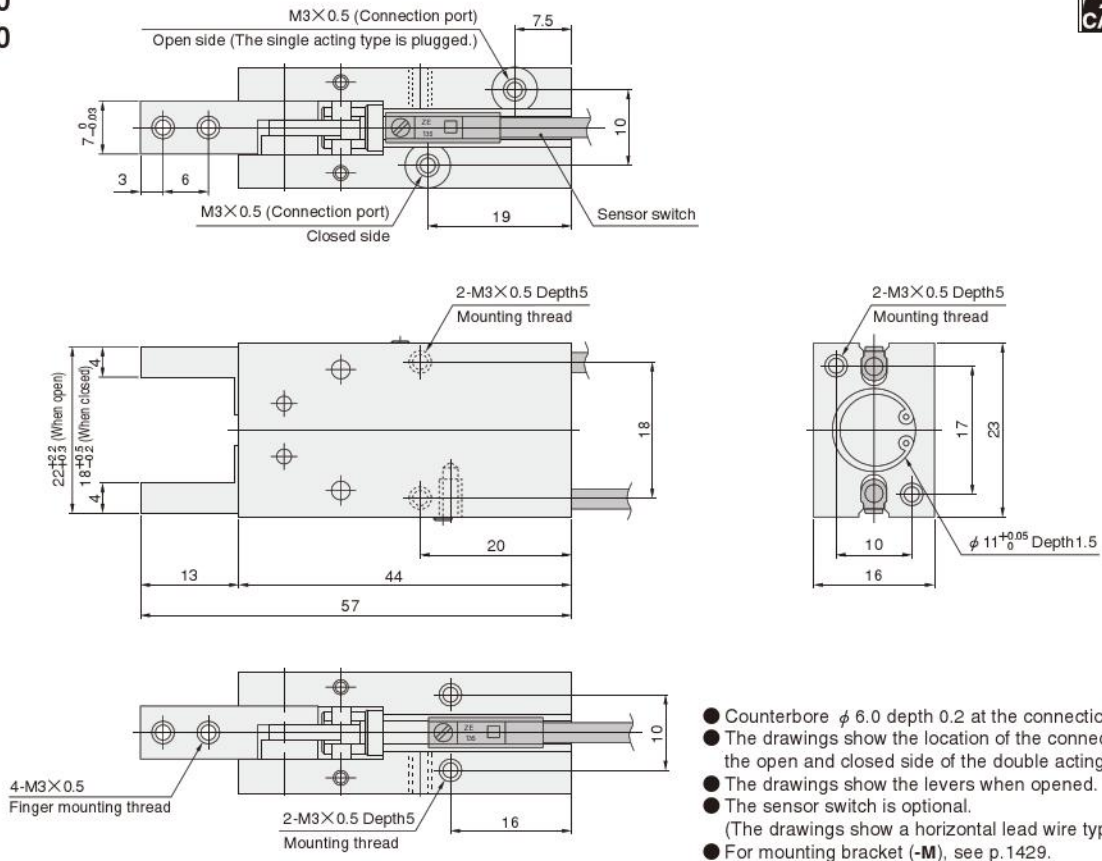

- Counterbore  $\phi 6.0$  depth 0.2 at the connection port.
- The drawings show the location of the connection ports for the open and closed side of the double acting type.
- The drawings show the levers when opened.
- The sensor switch is optional.  
(The drawings show a horizontal lead wire type.)
- For mounting bracket (-M), see p.1429.

NHBDP-16  
NHBRP-16

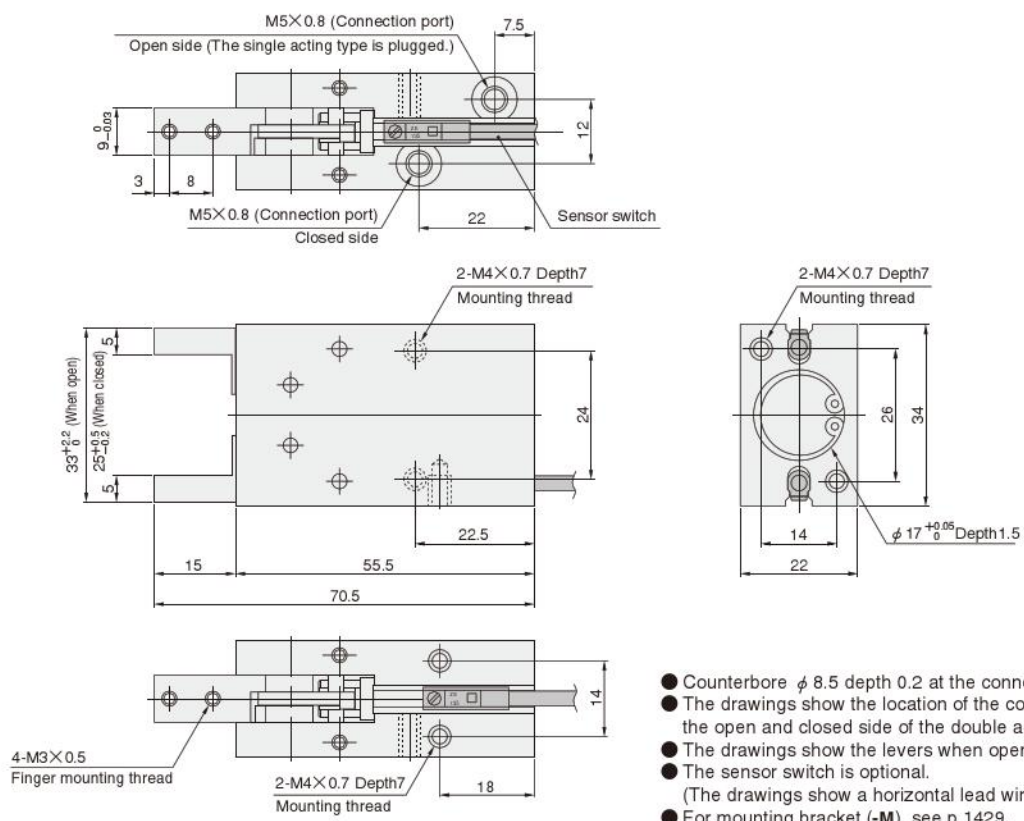

- Counterbore  $\phi 8.5$  depth 0.2 at the connection port.
- The drawings show the location of the connection ports for the open and closed side of the double acting type.
- The drawings show the levers when opened.
- The sensor switch is optional.  
(The drawings show a horizontal lead wire type.)
- For mounting bracket (-M), see p.1429.

AIR HANDS SERIES

# Dimensions of Parallel Type Plain Bearing Specification (mm)

## NHBDP-20 NHBRP-20

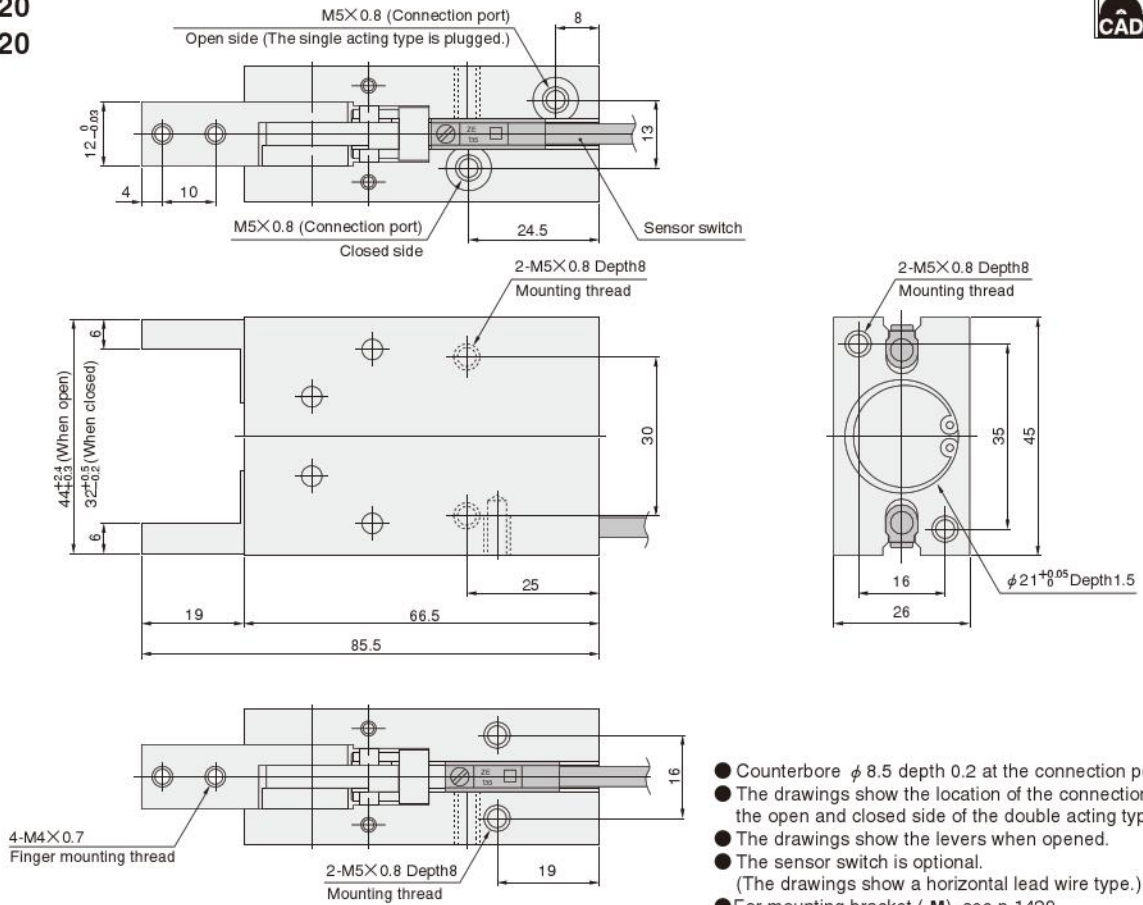

- Counterbore  $\phi 8.5$  depth 0.2 at the connection port.
- The drawings show the location of the connection ports for the open and closed side of the double acting type.
- The drawings show the levers when opened.
- The sensor switch is optional.  
(The drawings show a horizontal lead wire type.)
- For mounting bracket (-M), see p.1429.

## NHBDP-25 NHBRP-25

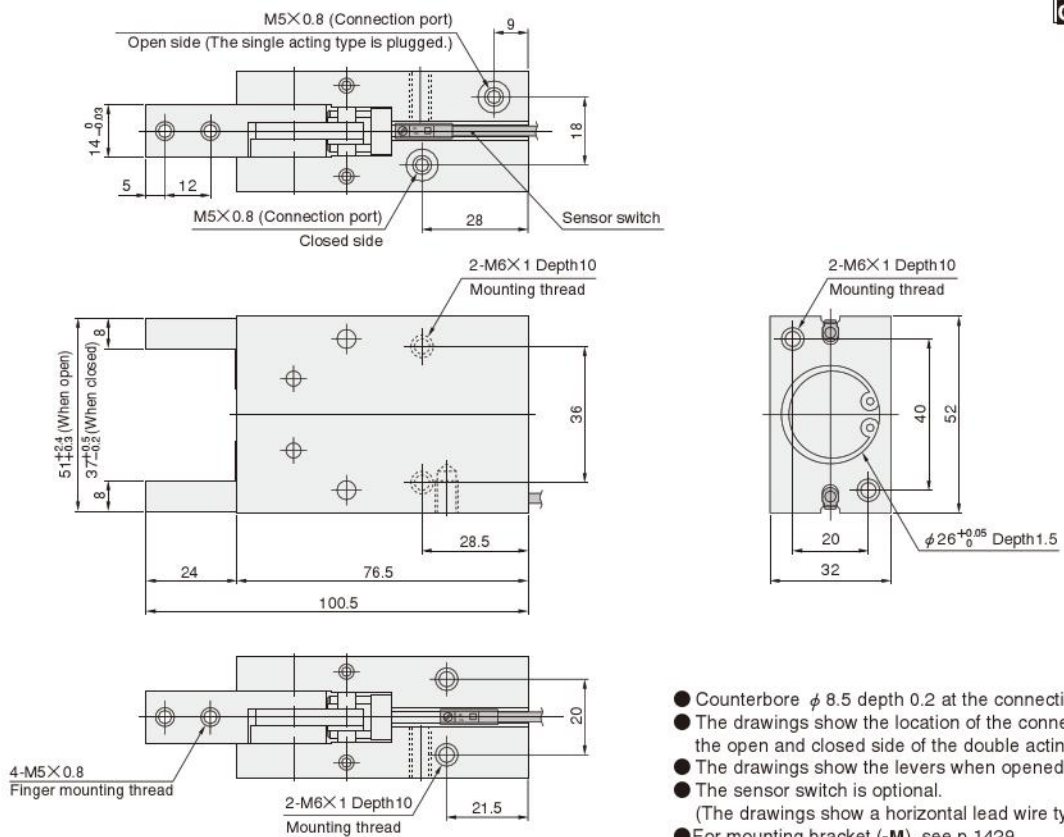

- Counterbore  $\phi 8.5$  depth 0.2 at the connection port.
- The drawings show the location of the connection ports for the open and closed side of the double acting type.
- The drawings show the levers when opened.
- The sensor switch is optional.  
(The drawings show a horizontal lead wire type.)
- For mounting bracket (-M), see p.1429.

# SENSOR SWITCHES

## Solid State Type

### Symbol

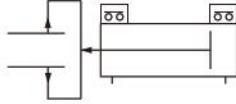

### Order Codes

#### ● Sensor switch only

#### ● NHC1 series



**Lead wire length**  
**A** — 1000mm [39in.]  
**B** — 3000mm [118in.]

**Sensor switch** —  
**ZE135** — Solid state type 2-lead wire with indicator lamp DC10~28V Horizontal lead wire  
**ZE235** — Solid state type 2-lead wire with indicator lamp DC10~28V Vertical lead wire  
**ZE155** — Solid state type 3-lead wire with indicator lamp DC4.5~28V Horizontal lead wire  
**ZE255** — Solid state type 3-lead wire with indicator lamp DC4.5~28V Vertical lead wire

#### ● NHB series



**Lead wire length**  
**A** — 1000mm [39in.]  
**B** — 3000mm [118in.]

**Sensor switch** —  
**ZE135** — Solid state type 2-lead wire  
**ZE235** — Solid state type 2-lead wire  
**ZE155** — Solid state type 3-lead wire  
**ZE255** — Solid state type 3-lead wire

#### ● WHDP series

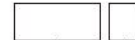

**Lead wire length**  
**A** — 1000mm [39in.]  
**B** — 3000mm [118in.]

**Sensor switch** —  
**ZE235** — Solid state type 2-lead wire  
**ZE255** — Solid state type 3-lead wire

#### ● Three-finger type linear guide specification (air hands)



**Lead wire length**  
**A** — 1000mm [39in.]  
**B** — 3000mm [118in.]

**Sensor switch** —  
**ZE135** — Solid state type 2-lead wire with indicator lamp DC10~28V Horizontal lead wire  
**ZE235** — Solid state type 2-lead wire with indicator lamp DC10~28V Vertical lead wire  
**ZE155** — Solid state type 3-lead wire with indicator lamp DC4.5~28V Horizontal lead wire  
**ZE255** — Solid state type 3-lead wire with indicator lamp DC4.5~28V Vertical lead wire

**Caution:** Sensor switch cannot be mounted on the mechanical hands.

● For details of sensor switches, see p.1544.

# Sensor Switch Operating Range and Response Differential

## ● Open/closed stroke differential (Open/closed angle differential)

The stroke differential (angle differential) between the point where the lever on one side moves and turns the switch ON and the point where the switch is turned OFF as the lever travels in the opposite direction.

## ● Operating position repeatability

When the lever on one side moves in the same direction, operating position repeatability is defined as the range of the deviation of the position where the switch is turned ON or turned OFF.

### Parallel type linear guide specification

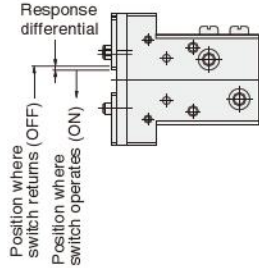

### Parallel type

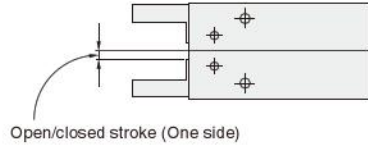

### Swing type

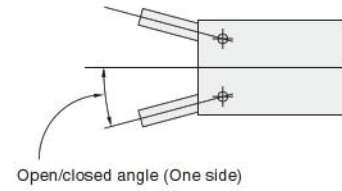

### Rack operation parallel type

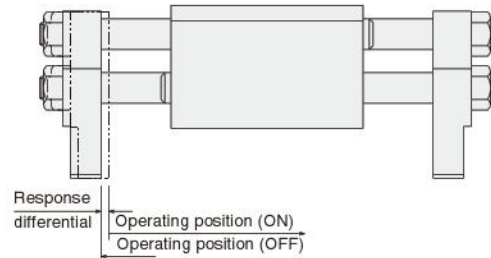

## ● NHC1 series

mm [in.]

Model	Open/closed stroke differential	Operating position repeatability
NHC1D-10	0.2 [0.008]	0.1 [0.004]
NHC1D-16	0.2 [0.008]	0.1 [0.004]
NHC1D-20	0.2 [0.008]	0.1 [0.004]
NHC1D-25	0.2 [0.008]	0.1 [0.004]

Remark: The above table shows reference values.

## ● Parallel type

mm [in.]

Model	Open/closed stroke differential	Operating position repeatability
NHB□PA-6	0.5 [0.020]	0.2 [0.008]
NHB□P□-10	0.5 [0.020]	0.2 [0.008]
NHB□P□-16	0.6 [0.024]	0.2 [0.008]
NHB□P□-20	0.6 [0.024]	0.2 [0.008]
NHB□P□-25	0.6 [0.024]	0.2 [0.008]

Remark: The above table shows reference values.

## ● Parallel type linear guide specification (with rubber cover)

mm [in.]

Model	Open/closed stroke differential	Operating position repeatability
NHB□PG(J)-8	0.5 [0.020]	0.2 [0.008]
NHB□PG(J)-10	0.5 [0.020]	0.2 [0.008]
NHB□PG(J)-16	0.8 [0.031]	0.2 [0.008]
NHB□PG(J)-20	0.8 [0.031]	0.2 [0.008]
NHBDPG-32	0.8 [0.031]	0.2 [0.008]

Remark: The above table shows reference values.

## ● Rack operation parallel type

mm [in.]

Model	Open/closed stroke differential	Operating position repeatability
WHDP-12	0.6 [0.024]	0.2 [0.008]
WHDP-16	0.6 [0.024]	0.2 [0.008]
WHDP-20	0.5 [0.020]	0.2 [0.008]
WHDP-25	0.5 [0.020]	0.2 [0.008]

Remark: The above table shows reference values.

## ● Swing type

Model	Open/closed angle differential	Operating position repeatability
NHB□S-8	3.0°	1.0°
NHB□S-10	2.0°	1.0°
NHB□S-16	1.5°	0.6°
NHB□S-20	1.5°	0.5°
NHB□S-25	1.0°	0.5°

Remark: The above table shows reference values.

## ● Swing type 180° open specification

Model	Open/closed angle differential	Operating position repeatability
NHBDSL-12	1.5°	0.5°
NHBDSL-16	1.0°	0.25° (one side)
NHBDSL-20	2.0°	0.2° (one side)
NHBDSL-25	3.0°	0.5°

Remark: The above table shows reference values.

## ● Swing type high precision, 180° open specification

Model	Open/closed angle differential	Operating position repeatability
NHBDSL-12	3.0°	0.5°
NHBDSL-16	1.5°	0.5°
NHBDSL-20	2.5°	0.5°

Remark: The above table shows reference values.

## ● Three-finger type linear guide specification (air hands)

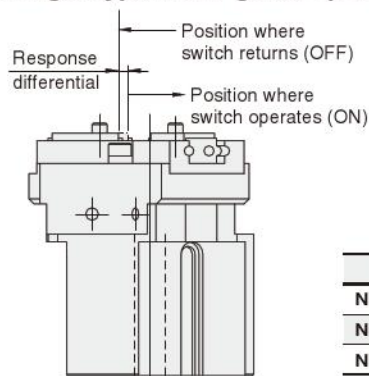

mm [in.]

Model	Maximum response differential
NHE1D-16	0.5 [0.020]
NHE1D-20	0.6 [0.024]
NHE1D-25	0.5 [0.020]

## Mounting Sensor Switch

### ● NHB series

Tighten the mounting screw after the sensor switch is inserted in the switch mounting groove in the direction of the arrow in the diagram and move to the proper location. Tightening torque of the mounting screw is  $0.1 \sim 0.2 \text{ N} \cdot \text{m}$  [ $0.9 \sim 1.8 \text{ in} \cdot \text{lbf}$ ].

**Caution:** Care must be exercised that the sensor switch cannot be inserted into the switch mounting groove from the diagram's top direction.

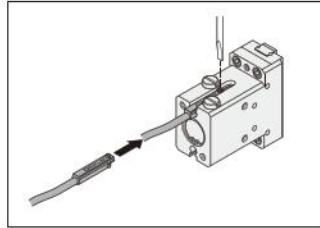

**Caution:** NHC1 series  
 NHB□PG(Y, L, J) series  
 CS-NHBDPG series  
 NHB□PA series  
 NHB□S-8  
 NHBDSLГ series  
 (Except NHB□PG-32 and NHB□PA-6)  
 Care must be exercised that a sensor switch cannot be mounted when the body is installed by using thru holes, as shown in the diagram to the right.

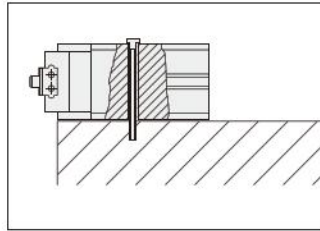

**Caution:** NHB□PA-25  
 When using a sensor switch on the lever open side, select the vertical lead wire type ZE235 or ZE255, and mount it in the facing shown in the illustration to the right.

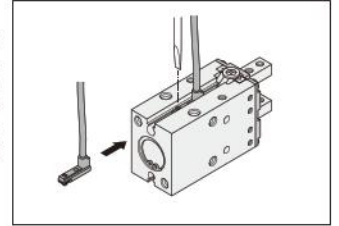

### ● WHDP series

Tighten the mounting screw after the sensor switch is inserted in the switch mounting groove in the direction of the arrow in the diagram below and move to the proper location. Tightening torque of the mounting screw is  $0.1 \sim 0.2 \text{ N} \cdot \text{m}$  [ $0.9 \sim 1.8 \text{ in} \cdot \text{lbf}$ ].

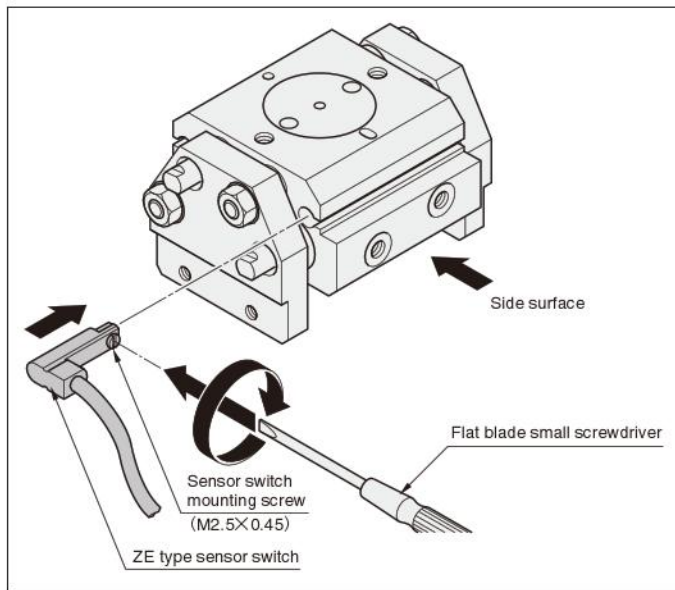

**Caution:** Care must be exercised that the sensor switch cannot be inserted into the switch mounting groove from the diagram's side surface direction.

### ● Three-finger type linear guide specification (air hands)

Insert the switch into the switch mounting groove. After setting in the mounting position, use a flat blade small screwdriver to tighten the switch mounting screw. Set the tightening torque to about  $0.1 \sim 0.2 \text{ N} \cdot \text{m}$  [ $0.9 \sim 1.8 \text{ in} \cdot \text{lbf}$ ]. Be sure to mount the sensor switch so that the side showing the model marking surface faces up.

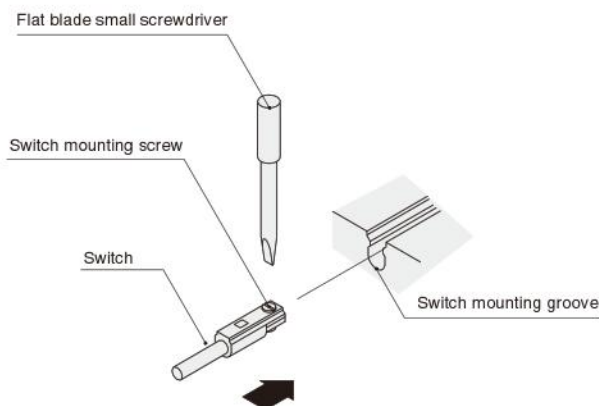

# Mounting Sensor Switch

## ● For swing type (Mount the sensor switch so that the model marking surface faces up.)

**《For inside gripping》**

- 1) Confirm the levers are completely open.
- 2) Push the switch into the groove on the body in the direction of the arrow.
- 3) By moving the sensor switch in the direction of the arrow, the lamp turns ON, and by moving it further, the lamp turns OFF.
- 4) By moving back the sensor switch in the direction of the arrow (opposite direction), the lamp turns ON, and it should be secured by the sensor switch mounting screw after moving it about 0.3 mm [0.012in.] further.

1) Confirm workpiece is inside gripped one.

**《For outside gripping》**

- 1) Confirm the levers are completely closed.
- 2) Push the switch into the groove on the body in the direction of the arrow.
- 3) By moving the switch in the direction of the arrow, the lamp turns ON.
- 4) Secure the sensor switch by the mounting screw after moving it about 0.3 mm [0.012in.] further in the direction of the arrow from where the lamp turned ON in step 3).

1) Confirm workpiece is outside gripped one.

Remark: Step 1) shows the location where you want to confirm the switch turns ON. Install and adjust it in accordance with step 1) ~ 4) above.

## ● For parallel type (Mount the sensor switch so that the model marking surface faces up.)

**《For inside gripping》**

**● For NHBDP□, NHBRP□**

- 1) Confirm the levers are completely open.
- 2) Push the switch into the groove on the body in the direction of the arrow.
- 3) By moving the switch in the direction of the arrow, the lamp turns ON.
- 4) Secure the sensor switch by the mounting screw after moving it about 0.3 mm [0.012in.] further in the direction of the arrow from where the lamp turned ON in step 3).

1) Confirm workpiece is inside gripped one.

**《For outside gripping》**

**● For NHBDPA□, NHBRPA□**

- 1) Confirm the levers are completely closed.
- 2) Push the switch into the groove on the body in the direction of the arrow.
- 3) By moving the sensor switch in the direction of the arrow, the lamp turns ON, and by moving it further, the lamp turns OFF.
- 4) By moving back the sensor switch in the direction of the arrow (opposite direction), the lamp turns ON, and it should be secured by the mounting screw after moving it about 0.3 mm [0.012in.] further.

1) Confirm workpiece is outside gripped one.

Remark: Step 1) shows the location where you want to confirm the switch turns ON. Install and adjust it in accordance with step 1) ~ 4) above.

● For parallel type linear guide specification (with rubber cover) (Mount the sensor switch so that the model marking surface faces up.)

《For inside gripping》

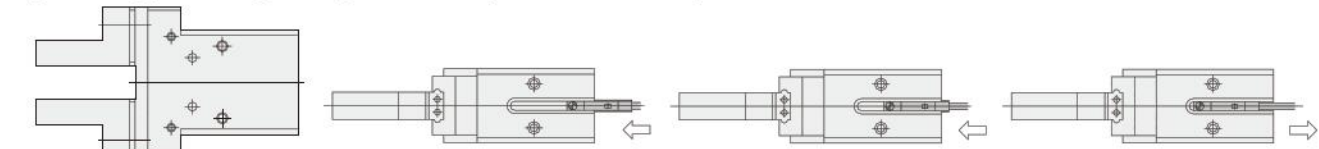
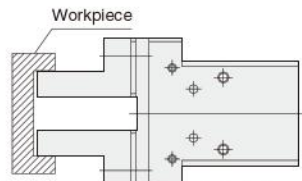
- 
- 1) Confirm the levers are completely open.
  - 2) Insert the switch into the groove on the body in the direction of the arrow.
  - 3) By moving the sensor switch in the direction of the arrow, the lamp turns ON, and by moving it further, the lamp turns OFF.
  - 4) By moving back the sensor switch in the direction of the arrow (opposite direction), the lamp turns ON, and it should be secured by the sensor switch mounting screw after moving it about 0.3 mm [0.012in.] further.
- 
- 1) Confirm workpiece is inside gripped one.

《For outside gripping》

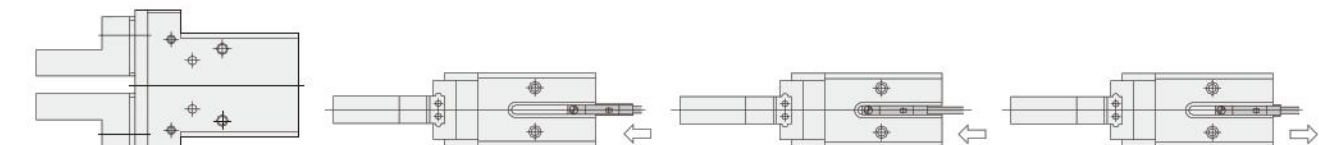
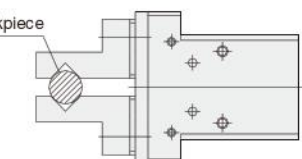
- 
- 1) Confirm the levers are completely closed.
  - 2) Insert the switch into the groove on the body in the direction of the arrow.
  - 3) By moving the switch in the direction of the arrow, the lamp turns ON.
  - 4) Secure the sensor switch by the mounting screw after moving it about 0.3 mm [0.012in.] further in the direction of the arrow from where the lamp turned ON in step 3).
- 
- 1) Confirm workpiece is outside gripped one.
- Remark: Step 1) shows the location where you want to confirm the switch turns ON. Install and adjust it in accordance with step 1) ~ 4) above.