

The space-saving **KNOCK CYLINDERS**

The total length has been shortened as much as possible. The compact, lightweight Knock Cylinder demonstrates space-saving effectiveness in various mounting configurations.

Double Acting Type

Cylinder Specification

■ Standard cylinder



■ Cylinder with magnet



Non-ion Specification



Mounting Type

- Basic type
- Foot mounting type
- Flange mounting type
- Pivot mounting with supporting bracket type
- Pivot mounting type

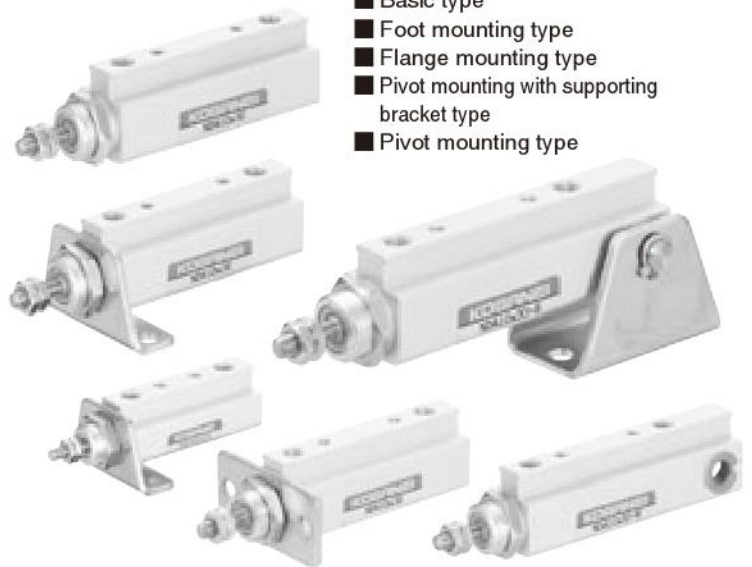

Piston Rod Specification

- Male thread
- Plain rod



Knuckles

- I type knuckle
- Y type knuckle



Sensor Switches

- Solid state type
 - ZC130
 - ZC153
- Reed switch type
 - CS5T
 - CS11T

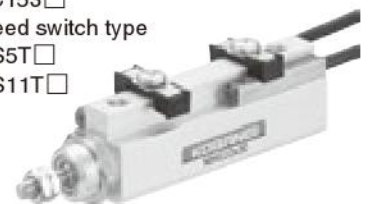

Double Acting Type Selection Chart

Bore size mm [in.]	Cylinder specification		Non-ion specification	Piston rod specification		Mounting type				Knuckles	
	Standard cylinder	Cylinder with magnet		Male thread	Plain rod	Basic type	Foot mounting type	Flange mounting type	Pivot mounting type (with mounting bracket)	I type	Y type
6 [0.236]	<input type="checkbox"/>	<input type="checkbox"/>	<input type="checkbox"/>	<input type="checkbox"/>	<input type="checkbox"/>	<input type="checkbox"/>	<input type="checkbox"/>	<input type="checkbox"/>	<input type="checkbox"/>	<input type="checkbox"/>	<input type="checkbox"/>
10 [0.394]	<input type="checkbox"/>	<input type="checkbox"/>	<input type="checkbox"/>	<input type="checkbox"/>	<input type="checkbox"/>	<input type="checkbox"/>	<input type="checkbox"/>	<input type="checkbox"/>	<input type="checkbox"/>	<input type="checkbox"/>	<input type="checkbox"/>
16 [0.630]	<input type="checkbox"/>	<input type="checkbox"/>	<input type="checkbox"/>	<input type="checkbox"/>	<input type="checkbox"/>	<input type="checkbox"/>	<input type="checkbox"/>	<input type="checkbox"/>	<input type="checkbox"/>	<input type="checkbox"/>	<input type="checkbox"/>

Double Acting Type

- Finely tuned configurations capable of dealing even with non-ion specification offer compact, lightweight features.
- 4 types and 5 classes of mounting types allow for a large variety of mounting configurations.
- Capable of mounting □4mm [0.157in.] sensor switches for excellent performance in a compact size.

Single Acting Push Type

- A centering location on the body improves mounting precision.
- Wrench flats built into the body provide secure mounting.
- Drawing presentation for positioning not required.

Single Acting Push Type

Piston Rod Specification



Male thread specification



Plain rod

Mounting



Panel mount



Foot mount



Insert mount

The same cylinder body applies to panel mounting, foot mounting and insert mounting types.

Single Acting Push Type Selection Chart

Bore size mm [in.]	Cylinder specification		Mounting type		
	Male thread	Plain rod	Panel mount	Foot mount	Insert mount
6 [0.236]	<input type="checkbox"/>	<input type="checkbox"/>	<input type="checkbox"/>	<input type="checkbox"/>	<input type="checkbox"/>
10 [0.394]	<input type="checkbox"/>	<input type="checkbox"/>	<input type="checkbox"/>	<input type="checkbox"/>	<input type="checkbox"/>
16 [0.630]	<input type="checkbox"/>	<input type="checkbox"/>	<input type="checkbox"/>	<input type="checkbox"/>	<input type="checkbox"/>

KNOCK CYLINDERS

Double Acting Type

Specifications

Item	Bore size mm [in.]		
	6 [0.236]	10 [0.394]	16 [0.630]
Operation type	Double acting type		
Media	Air		
Operating pressure range	0.15~0.7 MPa [psi.] [22~102]	0.1~0.7 [15~102]	0.08~0.7 [12~102]
Proof pressure	1.03 [149] MPa [psi.]		
Operating temperature range	0~60 [32~140] °C [°F]		
Operating speed range	50~500 [2.0~19.7] mm/s [in./sec.]		
Cushion	Rubber bumper		
Lubrication	Not required (If lubrication is required, use Turbine Oil Class 1 [ISO VG32] or equivalent.)		
Port size	M5×0.8		
Stroke tolerance	mm [in.] +1 [+0.039] 0 [0]		
Mounting type	Basic type, Foot mounting type, Flange mounting type, Pivot mounting type		

Symbol

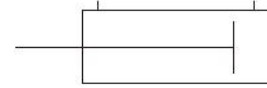

Bore Size and Stroke

Bore size	Standard strokes	
	mm	
6	5, 10, 15, 20	
10	5, 10, 15, 20, 25, 30	
16	5, 10, 15, 20, 25, 30	

Cylinder Thrust

Bore size mm [in.]	Piston rod dia. mm [in.]	Operation	Pressure area mm ² [in. ²]	Air pressure MPa [psi.]						
				0.1 [15]	0.2 [29]	0.3 [44]	0.4 [58]	0.5 [73]	0.6 [87]	0.7 [102]
6 [0.236]	3 [0.118]	Push side	28.3 [0.0439]	—	5.7 [1.28]	8.5 [1.91]	11.3 [2.54]	14.2 [3.19]	17 [3.82]	19.8 [4.45]
		Pull side	21.2 [0.0329]	—	4.2 [0.94]	6.4 [1.44]	8.5 [1.91]	10.6 [2.38]	12.7 [2.85]	14.8 [3.33]
10 [0.394]	5 [0.197]	Push side	78.5 [0.1216]	7.8 [1.75]	15.7 [3.53]	23.6 [5.31]	31.4 [7.06]	39.3 [8.83]	47.1 [10.59]	55 [12.36]
		Pull side	58.9 [0.0913]	5.9 [1.33]	11.8 [2.65]	17.7 [3.98]	23.6 [5.31]	29.5 [6.63]	35.3 [7.94]	41.2 [9.26]
16 [0.630]	6 [0.236]	Push side	201 [0.312]	20.1 [4.52]	40.2 [9.04]	60.3 [13.56]	80.4 [18.07]	100.5 [22.59]	120.6 [27.11]	140.7 [31.63]
		Pull side	172 [0.267]	17.2 [3.87]	34.4 [7.73]	51.6 [11.60]	68.8 [15.47]	86 [19.33]	103.2 [23.20]	120.4 [27.07]

Mass

Bore size mm	Stroke mm	Basic type		Pivot mounting type	Additional mass								
		Standard cylinder	Cylinder with magnet		With 1 sensor switch (Cylinder with magnet only)				Foot mounting bracket	Flange mounting bracket	Pivot mount- ing bracket (with pin)	I type knuckles	Y type knuckles (with pin)
					ZC130□	ZC153□	CS5T□	CS11T□					
6	5	15 [0.529]	18 [0.635]	18 [0.635]	20 [0.705]				7 [0.247]	5 [0.176]	14 [0.494]	—	—
	10	17 [0.600]	20 [0.705]	20 [0.705]	20 [0.705]				7 [0.247]	5 [0.176]	14 [0.494]	—	—
	15	19 [0.670]	22 [0.776]	22 [0.776]	20 [0.705]				7 [0.247]	5 [0.176]	14 [0.494]	—	—
	20	21 [0.741]	24 [0.847]	24 [0.847]	20 [0.705]				7 [0.247]	5 [0.176]	14 [0.494]	—	—
10	5	23 [0.811]	29 [1.023]	26 [0.917]	20 [0.705]				9 [0.317]	6 [0.212]	24 [0.847]	16 [0.564]	23 [0.811]
	10	26 [0.917]	32 [1.129]	29 [1.023]	20 [0.705]				9 [0.317]	6 [0.212]	24 [0.847]	16 [0.564]	23 [0.811]
	15	29 [1.023]	35 [1.235]	32 [1.129]	20 [0.705]				9 [0.317]	6 [0.212]	24 [0.847]	16 [0.564]	23 [0.811]
	20	32 [1.129]	38 [1.340]	35 [1.235]	20 [0.705]				9 [0.317]	6 [0.212]	24 [0.847]	16 [0.564]	23 [0.811]
	25	35 [1.235]	41 [1.446]	38 [1.340]	20 [0.705]				9 [0.317]	6 [0.212]	24 [0.847]	16 [0.564]	23 [0.811]
16	5	42 [1.481]	50 [1.764]	49 [1.728]	20 [0.705]				24 [0.847]	15 [0.529]	55 [1.940]	22 [0.776]	18 [0.635]
	10	46 [1.623]	54 [1.905]	53 [1.869]	20 [0.705]				24 [0.847]	15 [0.529]	55 [1.940]	22 [0.776]	18 [0.635]
	15	50 [1.764]	58 [2.046]	57 [2.011]	20 [0.705]				24 [0.847]	15 [0.529]	55 [1.940]	22 [0.776]	18 [0.635]
	20	54 [1.905]	62 [2.187]	61 [2.152]	20 [0.705]				24 [0.847]	15 [0.529]	55 [1.940]	22 [0.776]	18 [0.635]
	25	58 [2.046]	66 [2.328]	65 [2.293]	20 [0.705]				24 [0.847]	15 [0.529]	55 [1.940]	22 [0.776]	18 [0.635]

Calculation example: To add 2 sensor switches to the cylinder with magnet NDAS10×20: 38+(20×2)=78g [2.751oz.]

Remark: There are 2 types of sensor switch lead wire lengths.

A: 1000mm [39in.], B: 3000mm [118in.]

Inner Construction and Major Parts

● Standard cylinder

● Cylinder with magnet

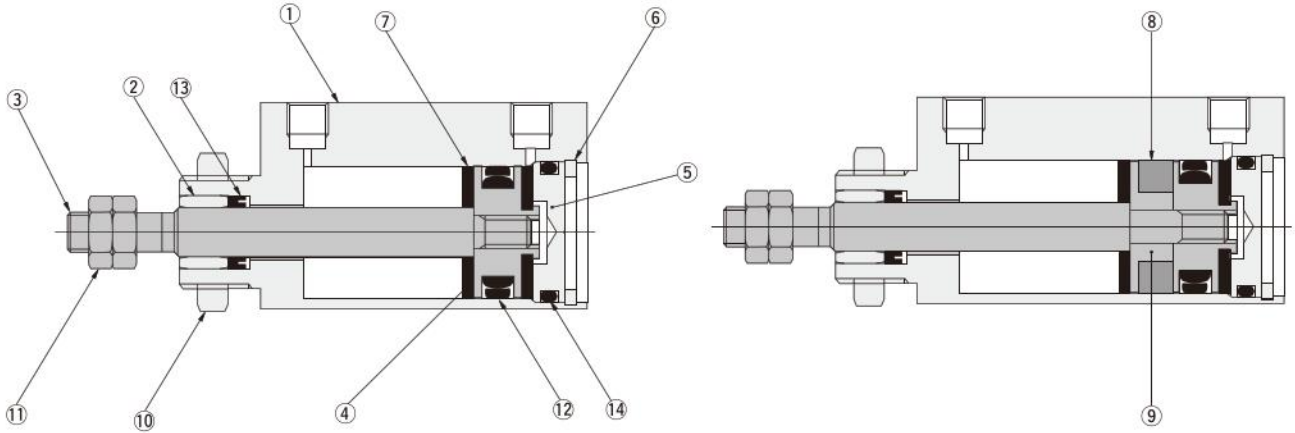

Major Parts and Materials

No.	Parts	Materials	
		Standard specification	Non-ion specification
①	Body	Aluminum alloy (anodized)	←
②	Rod bushing	Oil impregnated bronze	Special steel
③	Piston rod	Stainless steel	←
④	Piston	Brass	Aluminum
⑤	Head cover	Aluminum alloy (anodized)	←
⑥	Snap ring	Steel (nickel plated)	←
⑦	Bumper	Synthetic rubber (NBR)	←

Note: The $\phi 6$ body cannot be disassembled.

No.	Parts	Materials	
		Standard specification	Non-ion specification
⑧	Magnet	$\phi 6$: Sintered alloy magnet $\phi 10 \cdot \phi 16$: Plastic magnet	←
⑨	Magnet support	Brass	Aluminum
⑩	Mounting nut	Steel (nickel plated)	←
⑪	Rod end nut	Steel (nickel plated)	←
⑫	Piston seal	Synthetic rubber (NBR)	←
⑬	Rod seal		
⑭	O-ring		

Seals

Bore mm [in.]	Parts		
	Rod seal	Piston seal	O-ring
6 [0.236]	MY-6×3×2	COP-6L	6.9×4.5×1.2
10 [0.394]	MY-8×5×2	COP-10L	12×9×1.5
16 [0.630]	MY-9×6×2	COP-16L	17.2×14×1.6

Dimensions of Basic Type (mm)

NDA Bore size Stroke

CAD ϕ 6 : NDA-06
 ϕ 10 : NDA-10
 ϕ 16 : NDA-16

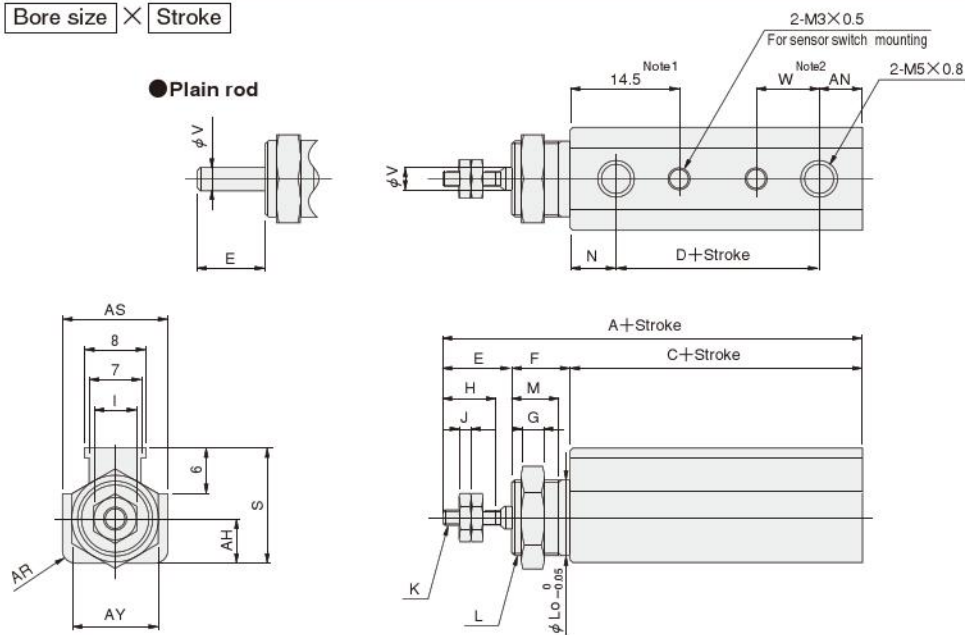

Type	Standard cylinder			Cylinder with magnet			E	F	G	H	I	J	K	L	Lo	M	N	S	V	W	AH	AN	AR	AS	AY
Code	A	C	D	A	C	D																			
6	36	19	7	41	24	12	9	8	3	7	5.5	1.8	M3×0.5	M10×1	10	6.5	6	15.5	3	8.5	6	6	R2	14	12
10	40	20	7	45	25	12	12	8	3	10	7	2.4	M4×0.7	M12×1	12	6.5	6	19	5	8.5	7	7	R2	15	14
16	44.5	20.5	7.5	49.5	25.5	12.5	14	10	4	12	8	3.2	M5×0.8	M14×1.25	14	8.5	6	25.5	6	8.5	9.5	7	R3	20	17

Notes: 1. Not available in the 5, 10, 15 stroke standard cylinder and the 5, 10 stroke cylinder with magnet.
 2. Not available in the 5 stroke standard cylinder.

Dimensions of Foot Mounting Type (mm)

NDA Bore size Stroke -1A

CAD ϕ 6 : NDA-06
 ϕ 10 : NDA-10
 ϕ 16 : NDA-16

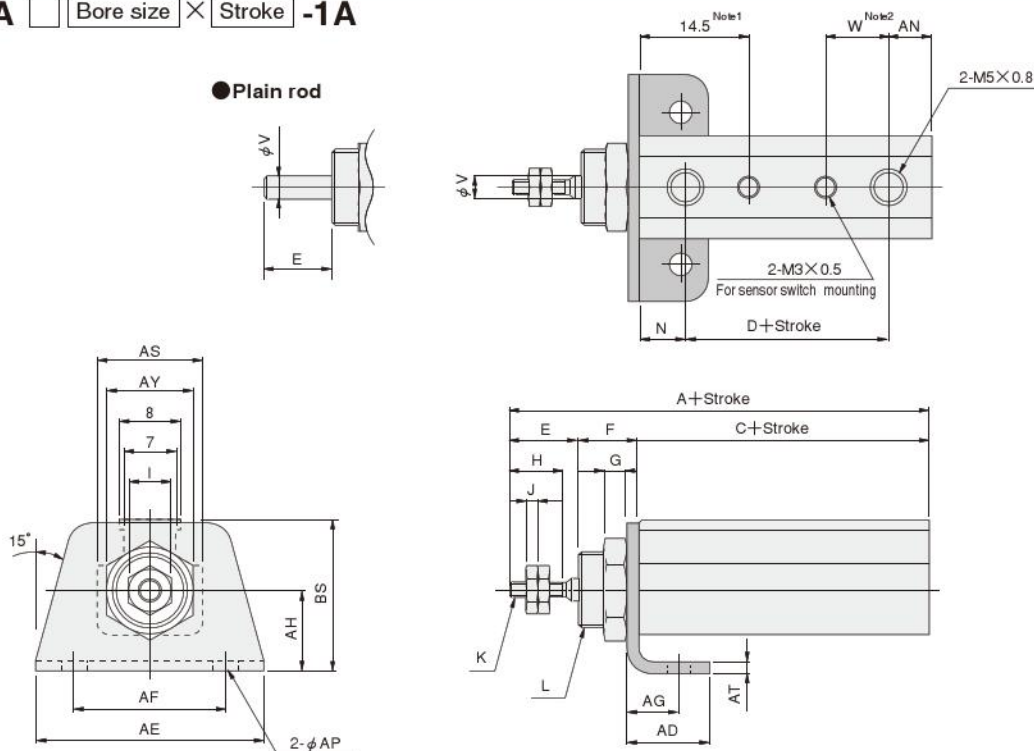

Type	Standard cylinder			Cylinder with magnet			E	F	G	H	I	J	K	L	N	V	W	AD	AE	AF	AG	AH	AN	AP	AS	AT	AY	BS
Code	A	C	D	A	C	D																						
6	36	19	7	41	24	12	9	8	3	7	5.5	1.8	M3×0.5	M10×1	6	3	8.5	11	28	20	7	11	6	3.4	14	1.6	12	20.5
10	40	20	7	45	25	12	12	8	3	10	7	2.4	M4×0.7	M12×1	6	5	8.5	12	33	24	7	13	7	4.5	15	1.6	14	25
16	44.5	20.5	7.5	49.5	25.5	12.5	14	10	4	12	8	3.2	M5×0.8	M14×1.25	6	6	8.5	16	43	30	10	18	7	5.5	20	2.3	17	34

Notes: 1. Not available in the 5, 10, 15 stroke standard cylinder and the 5, 10 stroke cylinder with magnet.
 2. Not available in the 5 stroke standard cylinder.

Dimensions of Flange Mounting Type (mm)

NDA Bore size × Stroke -3

 ϕ 6 : NDA-06
 ϕ 10 : NDA-10
 ϕ 16 : NDA-16

● Plain rod

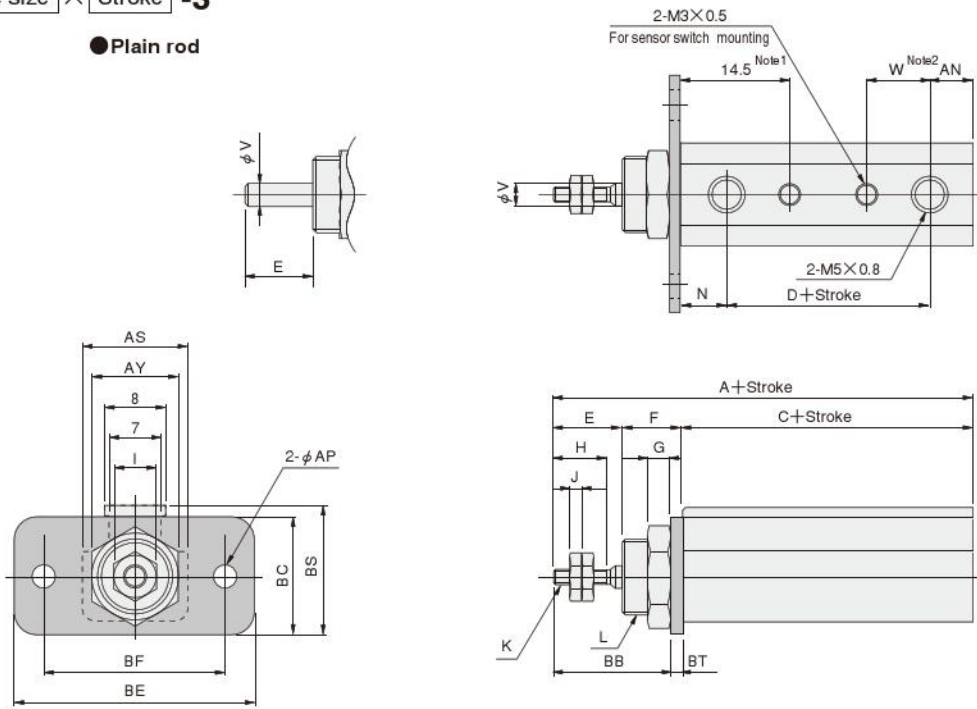

Type Code Bore	Standard cylinder			Cylinder with magnet			E	F	G	H	I	J	K	L	N	V	W	AN	AP	AS	AY	BB	BC	BE	BF	BS	BT
	A	C	D	A	C	D																					
6	36	19	7	41	24	12	9	8	3	7	5.5	1.8	M3×0.5	M10×1	6	3	8.5	6	3.4	14	12	15.4	16	32	24	17.5	1.6
10	40	20	7	45	25	12	12	8	3	10	7	2.4	M4×0.7	M12×1	6	5	8.5	7	4.5	15	14	18.4	18	37	28	21	1.6
16	44.5	20.5	7.5	49.5	25.5	12.5	14	10	4	12	8	3.2	M5×0.8	M14×1.25	6	6	8.5	7	5.5	20	17	21.7	22	49	36	27	2.3

Notes: 1. Not available in the 5, 10, 15 stroke standard cylinder and the 5, 10 stroke cylinder with magnet.
 2. Not available in the 5 stroke standard cylinder.

Dimensions of Pivot Mounting Type (mm)

NDA Bore size × Stroke -8

 ϕ 6 : NDA-06
 ϕ 10 : NDA-10
 ϕ 16 : NDA-16

● Plain rod

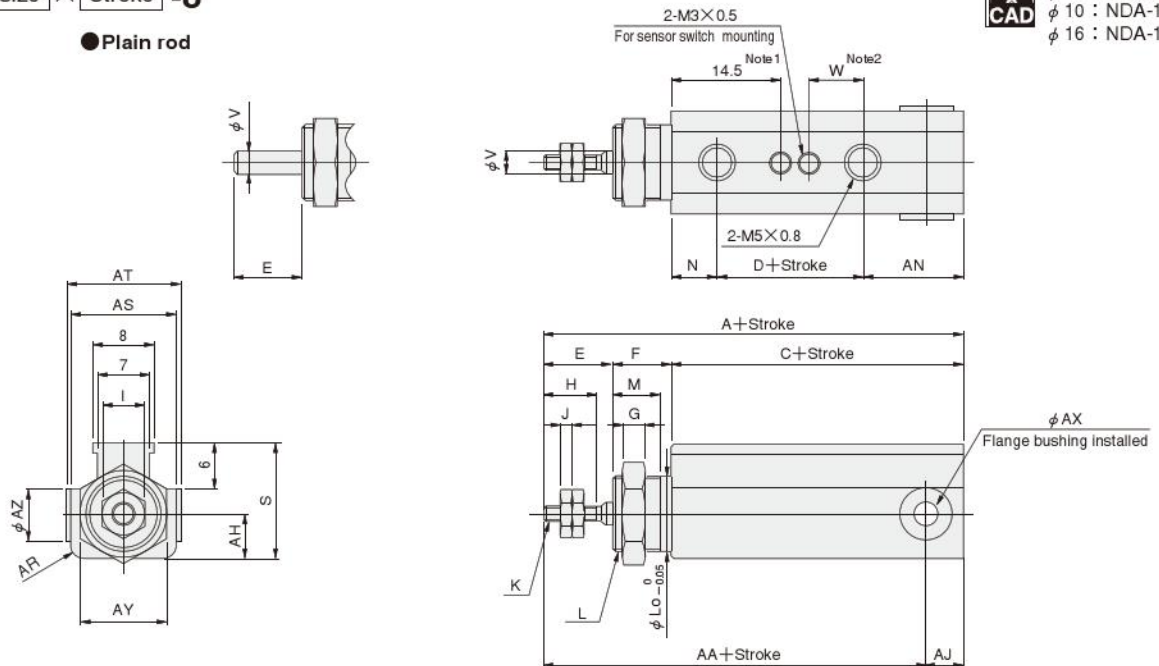

Type Code Bore	Standard cylinder			Cylinder with magnet			E	F	G	H	I	J	K	L	Lo	M	N	S	V	W	AH	AJ	AN	AR	AS	AT	AX	AY	AZ		
	A	C	D	AA	A	C																								D	AA
6	43.5	26.5	7	38.5	48.5	31.5	12	43.5	9	8	3	7	5.5	1.8	M3×0.5	M10×1	10	6.5	6	15.5	3	8.5	6	5	13.5	R2	14	15.6	3	12	7
10	50	30	7	43.5	55	35	12	48.5	12	8	3	10	7	2.4	M4×0.7	M12×1	12	6.5	6	19	5	8.5	7	6.5	17	R2	15	17	5	14	10
16	55.5	31.5	7.5	48.5	60.5	36.5	12.5	53.5	14	10	4	12	8	3.2	M5×0.8	M14×1.25	14	8.5	6	25.5	6	8.5	9.5	7	18	R3	20	22	6	17	12

Notes: 1. Not available in the 5, 10, 15 stroke standard cylinder and the 5, 10 stroke cylinder with magnet.
 2. Not available in the 5 stroke standard cylinder.

Dimensions of Pivot Mounting with Supporting Bracket Type (mm)

NDA Bore size Stroke **-8-8E**

CAD ϕ 6 : NDA-06
 ϕ 10 : NDA-10
 ϕ 16 : NDA-16

KNOCK CYLINDERS

● Plain rod

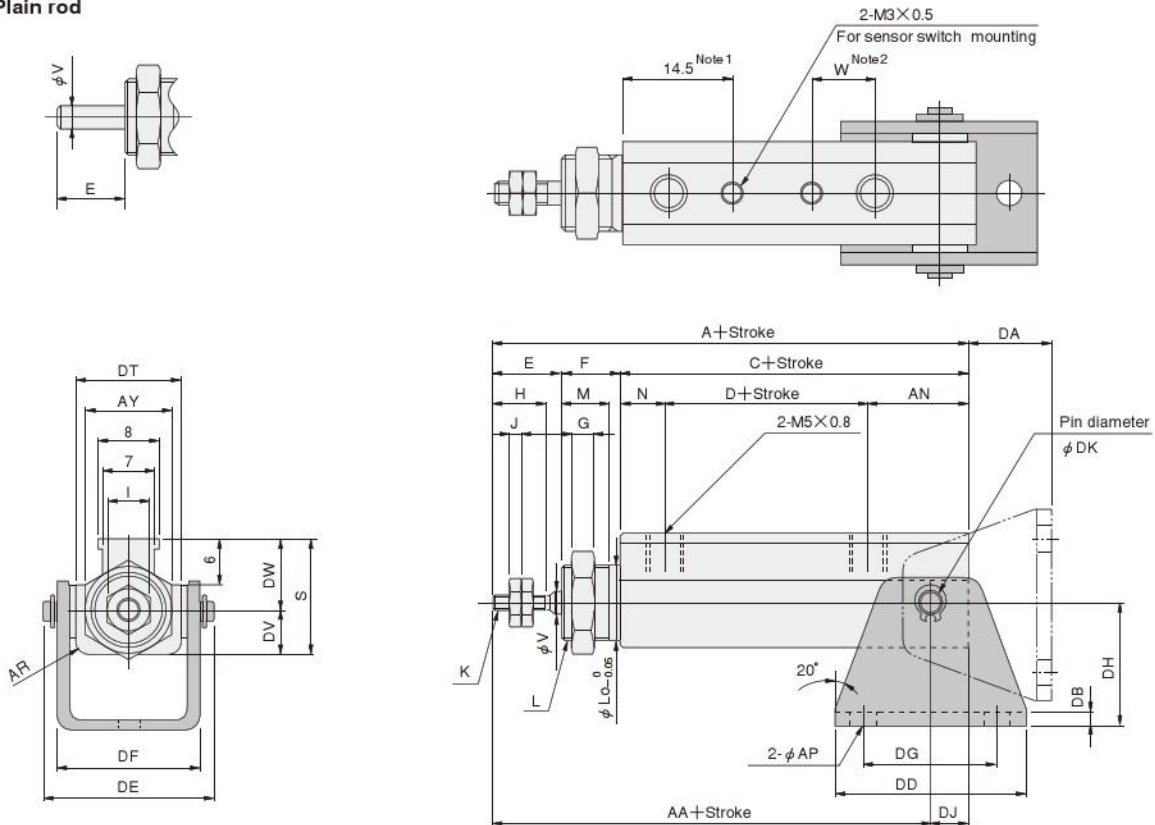

Type	Standard cylinder			Cylinder with magnet																																		
	A	C	D	AA	A	C	D	AA	E	F	G	H	I	J	K	L	L ₀	M	N	S	V	W	AN	AP	AR	AY	DA	DB	DD	DE	DF	DG	DH	DJ	DK	DT	DW	DV
6	43.5	26.5	7	38.5	48.5	31.5	12	43.5	9	8	3	7	5.5	1.8	M3×0.5	M10×1	10	6.5	6	15.5	3	8.5	13.5	3.4	R2	12	11	1.6	26	22.7	19	18	16	5	3	14	9.5	6
10	50	30	7	43.5	55	35	12	48.5	12	8	3	10	7	2.4	M4×0.7	M12×1	12	6.5	6	19	5	8.5	17	4.5	R2	14	13.5	1.6	33	24.5	20.5	24	20	6.5	5	15	12	7
16	55.5	31.5	7.5	48.5	60.5	36.5	12.5	53.5	14	10	4	12	8	3.2	M5×0.8	M14×1.25	14	8.5	6	25.5	6	8.5	18	5.5	R3	17	18	2.3	42	31.1	27	29	25	7	6	20	16	9.5

Notes: 1. Not available in the 5, 10, 15 stroke standard cylinder and the 5, 10 stroke cylinder with magnet.
 2. Not available in the 5 stroke standard cylinder.

● Dimensions of pin for pivot mounting bracket
 [With 2 snap rings]

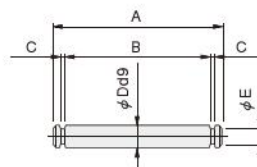

Bore size	A	B	C	ϕ D	ϕ E	Snap ring
6 [0.236 in.]	22.7	19.7	0.68	3 $\begin{smallmatrix} -0.020 \\ -0.045 \end{smallmatrix}$	2.4	E type
10 [0.394 in.]	24.5	21.1	0.7	5 $\begin{smallmatrix} -0.030 \\ -0.060 \end{smallmatrix}$	4.8	C type
16 [0.630 in.]	31.1	27.5	0.8	6 $\begin{smallmatrix} -0.030 \\ -0.060 \end{smallmatrix}$	5.7	C type

KNOCK CYLINDERS

Single Acting Push Type

Symbol

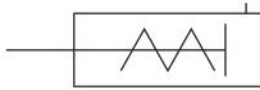

Specifications



Item	Bore size mm [in.]		
	6 [0.236]	10 [0.394]	16 [0.630]
Operation type	Single Acting Push Type		
Media	Air		
Operating pressure range MPa [psi.]	0.2~0.7 [29~102]	0.15~0.7 [22~102]	
Proof pressure MPa [psi.]	1.03 [149]		
Operating temperature range °C [°F]	0~60 [32~140]		
Operating speed range mm/s [in./sec.]	50~500 (In applications with high load ratio or high speed, use externally mounted stopper.) [2.0~19.7]		
Cushion	None		
Lubrication	Not required (If lubrication is required, use Turbine Oil Class 1 [ISO VG32] or equivalent.)		
Mounting type	Panel mount, Foot mount, Insert mount		
Port size	M5 X 0.8		
Stroke tolerance mm [in.]	+1 [+0.039] 0 0		



Cylinder Thrust (Push Side)

Bore size mm [in.]	Pressure area mm ² [in. ²]	Air pressure MPa [psi]					
		0.2 [29]	0.3 [44]	0.4 [58]	0.5 [73]	0.6 [87]	0.7 [102]
6 [0.236]	28.3 [0.0439]	2.3 [0.52]	5.1 [1.15]	7.9 [1.78]	10.8 [2.43]	13.6 [3.06]	16.4 [3.69]
10 [0.394]	78.5 [0.1216]	8.3 [1.87]	16.2 [3.64]	24.0 [5.40]	31.9 [7.17]	39.7 [8.92]	47.6 [10.70]
16 [0.630]	201 [0.312]	25.5 [5.73]	45.6 [10.25]	65.7 [14.77]	85.8 [19.29]	105.9 [23.81]	126.0 [28.32]

Order Codes for Single Acting Push Type

System (Made to order)
Blank : Standard specifications
NCU : Non-ion specification
 ● Counter-measured for preventing generation of copper ions
 ● Made to order

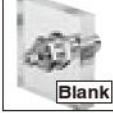
Piston rod specification
 Male thread  **Blank**
 Plain rod  **-N**

Mounting type
 Panel mount  **Blank**
 Foot mount  **-1**
 Insert mount  **-6**

● With mounting bolt
 ● Mounting bracket is included at shipping.

● Gasket is included at shipping.

Basic type: **NSA** Bore size X Stroke: **X**
 Order code examples: **-NCU**, **-N**, **-1**, **-6**

Remark: For the cylinder joint and cylinder rod end mounted on the piston rod end, see p.1568.

Bore Size and Stroke

Bore size	Standard strokes	
	mm	
6	5, 10, 15	
10	5, 10, 15	
16	5, 10, 15	

Mass

Mounting type	Bore size mm	Stroke mm		
		5	10	15
Panel mount Insert mount	6	13 [0.459]	15 [0.529]	17 [0.600]
	10	28 [0.988]	31 [1.093]	35 [1.235]
Foot mount	16	77 [2.716]	85 [2.998]	94 [3.316]
	6	29 [1.023]	31 [1.093]	33 [1.164]
	10	58 [2.046]	61 [2.152]	65 [2.293]
	16	166 [5.855]	174 [6.138]	183 [6.455]

Remarks: 1. One mounting nut is included with the panel mount and insert mount.
 2. Two mounting bolts with foot mounting brackets are included with the foot mount.

Spring Return Force

Bore size mm [in.]	Zero stroke		End of stroke	
	N [lbf.]		N [lbf.]	
6 [0.236]	1.5 [0.34]	3.4 [0.76]	1.5 [0.34]	3.4 [0.76]
10 [0.394]	2.5 [0.56]	7.4 [1.66]	2.5 [0.56]	7.4 [1.66]
16 [0.630]	5.4 [1.21]	14.7 [3.30]	5.4 [1.21]	14.7 [3.30]

Remarks: 1. Avoid application that carries loads on the spring return side.
 2. This value is virtually constant regardless of the cylinder stroke.

Inner Construction and Major Parts (Figure below shows Insert mount type)

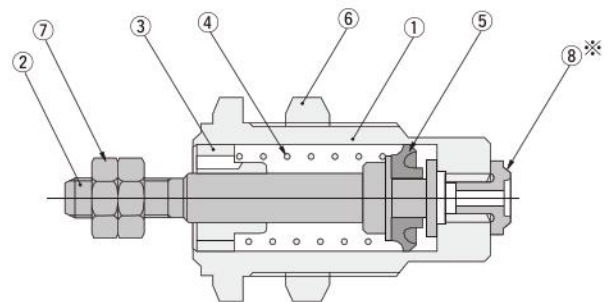

Major Parts and Materials

No.	Parts	Materials	
		Standard specification	Non-ion specification
①	Cylinder body	Brass (nickel plated)	Special steel
②	Piston, Piston rod	Stainless steel	←
③	Rod bushing	Phosphor bronze	Special steel
④	Spring	Steel (zinc plated)	←
⑤	Piston seal	Synthetic rubber (NBR)	←
⑥	Mounting nut	Brass (nickel plated)	Special steel
⑦	Rod end nut	Steel (nickel plated)	←
⑧*	Gasket	Synthetic rubber (NBR)	←

*The gasket is for the insert mount only.

Dimensions of Panel and Insert Mount Type (mm)

NSA Bore size × Stroke

 φ 6 : NSA-06
 φ 10 : NSA-10
 φ 16 : NSA-16

● Panel mount

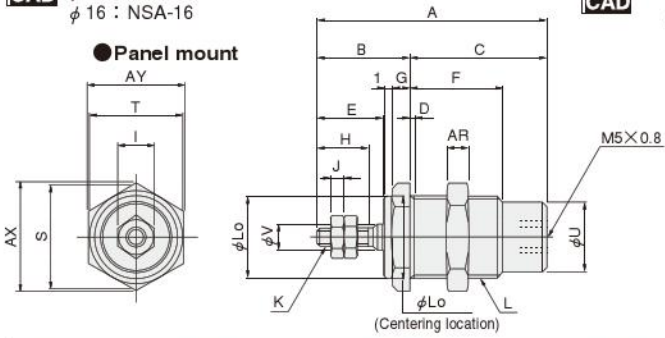

NSA Bore size × Stroke -N

 NSA-N

● Plain rod

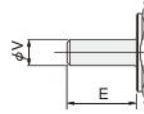

NSA Bore size × Stroke -6

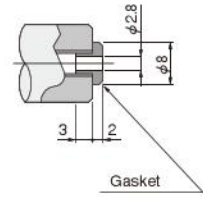

 NSA-INS

● Insert mount

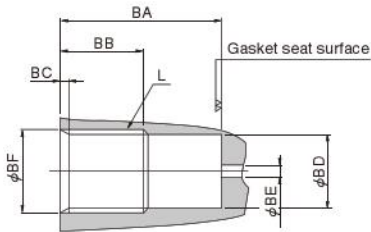

Code Stroke Bore	A			B	C			D	E	F			G	H	I	J	K	L	L _o	S	T	U	V	AR	AX	AY
	5	10	15		5	10	15			5	10	15														
6	29	36	43	13	16	23	30	1.5	9	11.5	13	13	2.5	7	5.5	1.8	M3×0.5	M10×1	10 ⁰ _{-0.05}	13.9	12	8.5	3	3	13.9	12
10	34.5	41	48	16.5	18	24.5	31.5	1.5	12	13.5	16.5	16.5	3	10	7	2.4	M4×0.7	M14×1.25	14 ⁰ _{-0.05}	18.5	16	12.3	5	4	19.6	17
16	39.5	45.5	52	19.5	20	26	32.5	2	14	15.5	18	18	4	12	8	3.2	M5×0.8	M22×1.5	22 ⁰ _{-0.05}	27.7	24	20	6	5	31.2	27

● Insert mounting hole



Code Stroke Bore	BA			BB			BC	BD	BE	BF
	5	10	15	5	10	15				
6	17.4±0.2	24.4±0.2	31.4±0.2	13 or more	15 or more	15 or more	2	9	4 or less	10 ^{+0.15} _{+0.05}
10	19.4±0.2	25.9±0.2	32.9±0.2	15 or more	18 or more	18 or more	2	12.7	4 or less	14 ^{+0.15} _{+0.05}
16	21.4±0.2	27.4±0.2	33.9±0.2	17 or more	20 or more	20 or more	2.5	20.4	4 or less	22 ^{+0.15} _{+0.05}

Dimensions of Foot Mount Type (mm)

NSA Bore size × Stroke -1

 NSA-FOOT

● Plain rod

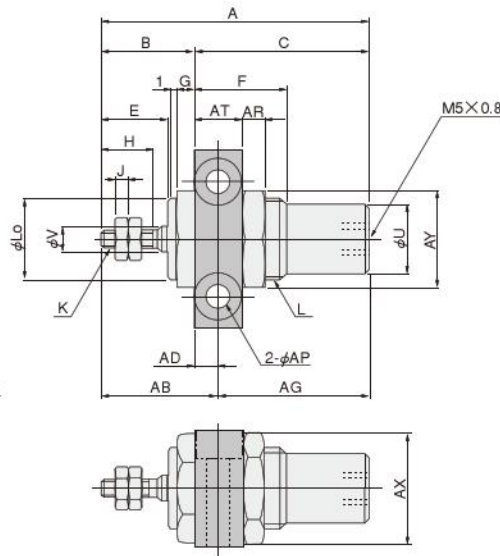
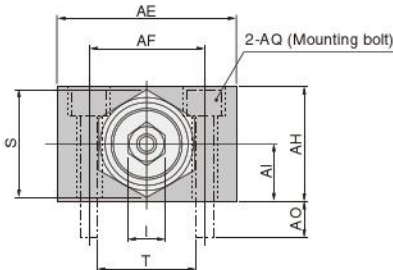
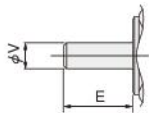

Code Stroke Bore	A			B	C			E	F			G	H	I	J	K	L	L _o	S	T	U	V	AB	AD	AE
	5	10	15		5	10	15		5	10	15														
6	29	36	43	13	16	23	30	9	11.5	13	13	2.5	7	5.5	1.8	M3×0.5	M10×1	10 ⁰ _{-0.05}	13.9	12	8.5	3	17.5	4.5	22
10	34.5	41	48	16.5	18	24.5	31.5	12	13.5	16.5	16.5	3	10	7	2.4	M4×0.7	M14×1.25	14 ⁰ _{-0.05}	18.5	16	12.3	5	21	4.5	32
16	39.5	45.5	52	19.5	20	26	32.5	14	15.5	18	18	4	12	8	3.2	M5×0.8	M22×1.5	22 ⁰ _{-0.05}	27.7	24	20	6	25.5	6	42

Code Stroke Bore	AF	AG			AH	AI	AO	AP			AQ			AR	AT	AX	AY
		5	10	15							(Comes with foot mounting bracket)						
6	14	11.5	18.5	25.5	14	7	(5.3)	φ 3.4	Counterbore	φ 6.2	Depth 3.3	Hexagon socket head bolt M3 × 0.5	Below head length 16	3	9	13.9	12
10	20	13.5	20	27	20	10	(6.4)	φ 4.5	Counterbore	φ 7.8	Depth 4.4	Hexagon socket head bolt M4 × 0.7	Below head length 22	4	9	19.6	17
16	30	14	20	26.5	32	16	(8.4)	φ 5.5	Counterbore	φ 9.5	Depth 5.4	Hexagon socket head bolt M5 × 0.8	Below head length 35	5	12	31.2	27

BRACKETS (FOR DOUBLE ACTING TYPE)

Mounting Brackets, Knuckles, Brackets with Pin

Mounting Brackets

Bore size mm [in.]	Mounting brackets	Foot mounting bracket	Flange mounting bracket	Pivot mounting bracket (with pin and snap ring)
6 [0.236]		1A-NDA6	3-NDA6	8E-NDA6
10 [0.394]		1A-NDA10	3-NDA10	8E-NDA10
16 [0.630]		1A-NDA16	3-NDA16	8E-NDA16

Remarks: 1. See p.84~86 for dimensions of the mounting brackets.
2. Pivot mounting bracket can be used only on the pivot mount type cylinder.

Order codes

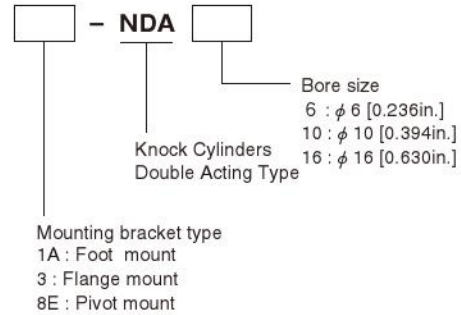

Knuckles

Bore size mm [in.]	Mounting brackets	I type knuckle	Y type knuckle (With pin)
10 [0.394]		I-NDA10	Y-NDA10
16 [0.630]		I-NDA16	Y-NDA16

Order codes

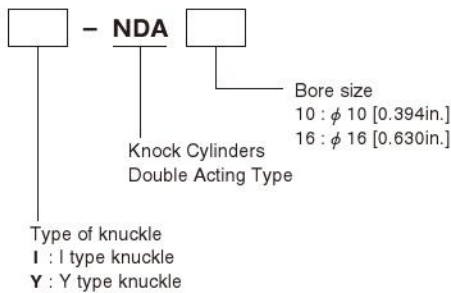

I type

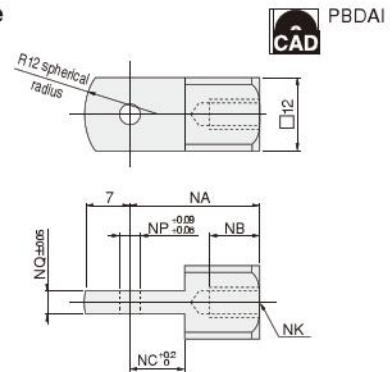

Code	NA	NB	NC	NK	NP	NQ
10 [0.394]	21	8	9	M4×0.7	3.2	3.1
16 [0.630]	25	8	14	M5×0.8	5	6.4

Y type

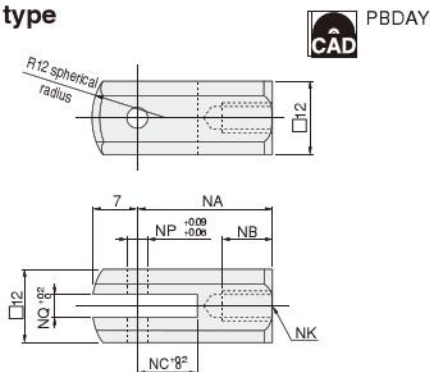

Code	NA	NB	NC	NK	NP	NQ
10 [0.394]	21	8	10	M4×0.7	3.2	3.2
16 [0.630]	21	11	10	M5×0.8	5	6.5

Pin and bracket for Y type knuckle

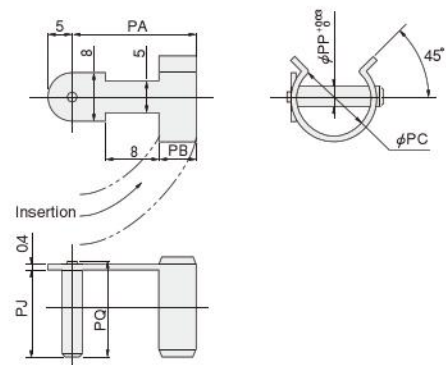

Code	PA	PB	PC	PJ	PP	PQ
10 [0.394]	17	5	14	13.5	3.2	(15)
16 [0.630]	17	5	14	13.5	5	(15)

SENSOR SWITCHES

Solid State Type, Reed Switch Type

Symbol

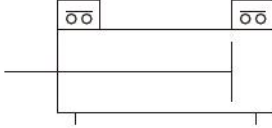

Order Codes (For Sensor Switches Only)

	Sensor switch model	Option Lead wire length	With sensor holder
Solid state type With indicator lamp DC10~28V	ZC130	A B	-NDAS
Solid state type With indicator lamp DC4.5~28V	ZC153		
Reed switch type Without indicator lamp DC5~28V AC85~115V	CS5T		
Reed switch type With indicator lamp DC10~28V	CS11T		

- A : 1000mm [39in.]
- B : 3000mm [118in.]

● The same sensor holder is used for $\phi 6$, $\phi 10$, and $\phi 16$.

- For sensor switch details, see p.1544.
- ★ Order code for the sensor holder only. C1-NDAS

Moving Sensor Switch

- Loosening mounting screw allows the sensor switch to be moved freely in the cylinder's axial direction.
- Tighten the mounting screw with a tightening torque of 19.6N·cm [1.73in·lbf] or less.

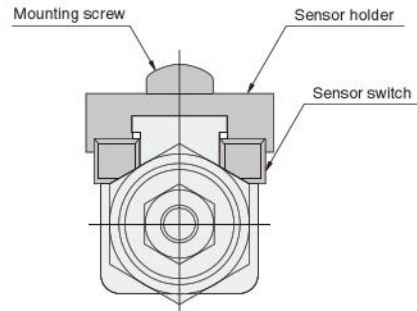

Minimum Cylinder Stroke When Using Sensor Switch

Bore size	Solid state type sensor switch		Reed switch type sensor switch	
	Mounting 2 pcs.	Mounting 1 pc.	Mounting 2 pcs.	Mounting 1 pc.
6 [0.236]	5	5	10	5
10 [0.394]	[0.197]	[0.197]	[0.394]	[0.197]
16 [0.630]				

Remark: In the reed switch type sensor switch, 1 sensor switch installation is standard for the 5mm cylinder stroke.

Sensor Switch Operating Range, Response Differential and Maximum Sensing Location

- Operating range: ℓ
The distance the piston travels in one direction, while the switch is in the ON position.
- Response differential: C
The distance between the point where the piston turns the switch ON and the point where the switch is turned OFF as the piston travels in the opposite direction.

Bore size	ZC130□, ZC153□		CS5T□, CS11T□	
	Operating range	Response differential	Operating range	Response differential
6 [0.236]	2.5~4.0 [0.098~0.157]	0.3 [0.012] or less	3.5~7.5 [0.138~0.295]	1.3 [0.051] or less
10 [0.394]	2.0~4.0 [0.079~0.157]	0.3 [0.012] or less	3.5~8.5 [0.138~0.335]	1.6 [0.063] or less
16 [0.630]	2.5~4.0 [0.098~0.157]	0.3 [0.012] or less	5.0~10.5 [0.197~0.413]	1.9 [0.075] or less

Remark: The above table shows reference values.

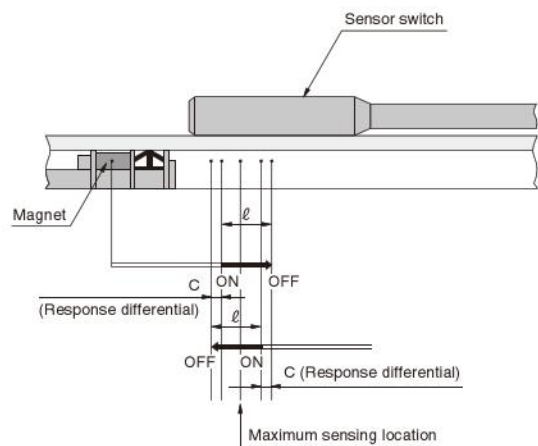

Mounting Location of End of Stroke Detection Sensor Switch

● For strokes 5 and 10

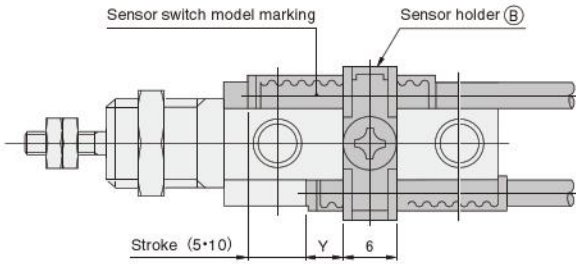

● For stroke 15 and larger

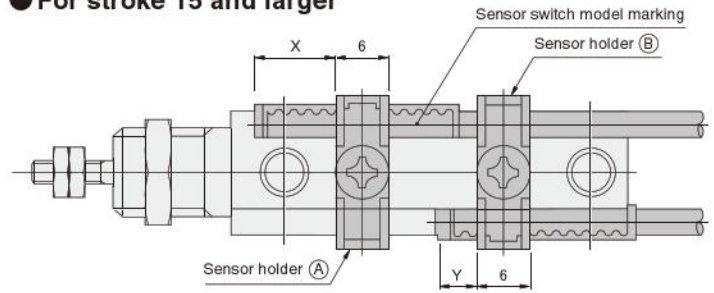

mm [in.]

Bore size	Mounting location	Sensor switch model			
		ZC130□	ZC153□	CS5T□	CS11T□
6, 10 [0.236, 0.394]	X	10 [0.394]	8.5 [0.335]	12 [0.472]	
	Y	5 [0.197]	3.5 [0.138]	7 [0.276]	
16 [0.630]	X	10.5 [0.413]	9 [0.354]	12.5 [0.492]	
	Y	5.5 [0.217]	4 [0.157]	7.5 [0.295]	

- Remarks:
1. The table at left gives reference values for the standard strokes. For the procedure to find-out the best position, see p.92.
 2. The above figures show the piping connection port when it has been turned to face upward.
 3. Mount the sensor switch so that the surface showing the model marking faces up.
 4. Sensor holder (A) is not available for the 5mm and 10mm strokes, and only sensor holder (B) is available. Two sensor switches can be mounted with a single sensor holder (B). In this case, the sensor switch mounting position on the rod side becomes the Y dimension (shown in the figure) + stroke.

Dimensions of Sensor Switch Mounting (mm)

● ϕ 6 [0.236in.]

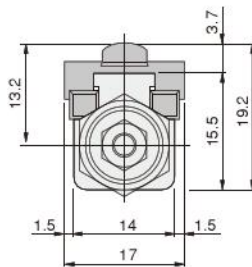

● ϕ 10 [0.394in.]

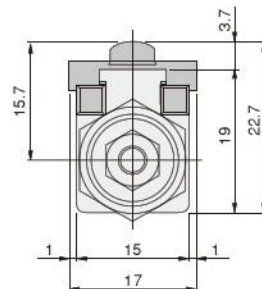

● ϕ 16 [0.630in.]

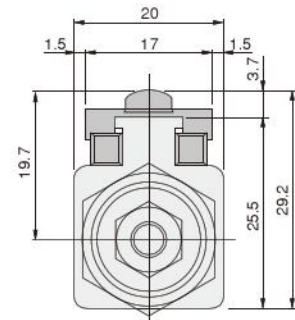



Mounting

Double acting type

- In applications with high load ratio or high speed, use an externally mounted stopper to prevent direct shock to the cylinder.
- Do not let the tightening torque for the mounting nut exceed the figures in the table below.

Bore size	Maximum tightening torque
6 [0.236in.]	1079 [95.5]
10 [0.394in.]	1275 [113]
16 [0.630in.]	1961 [174]

N·cm [in·lbf]

Single acting push type

- Using the centering location on the body can improve mounting precision on panel mounting. In addition, set the end face of the wrench flat as a reference plane does not need any adjustment of the rod end position. Moreover, the rod end position can be freely set through the use of cylindrical spacer matching the outer diameter of the cylinder body. For the maximum thickness of the panel, use the values in the table below as guidelines.

● Panel mounting

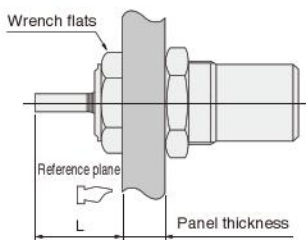

● Panel mounting

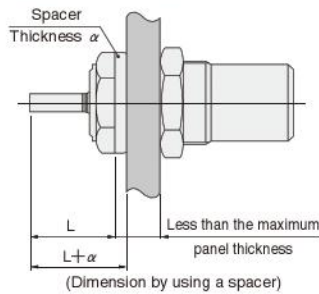

Bore size	Maximum panel thickness
6 [0.236]	8 [0.315]
10 [0.394]	9 [0.354]
16 [0.630]	10 [0.394]

mm [in.]

- Do not let the tightening torque for the mounting nut exceed the figures in the table below.

Bore size	Maximum tightening torque
6 [0.236in.]	1226 [109]
10 [0.394in.]	1716 [152]
16 [0.630in.]	4903 [434]

N·cm [in·lbf]

- Let the surface roughness of the bottom of the insert mounting hole (gasket seat surface) be of medium finish (▽▽). Moreover, mounting without a gasket can be done by applying a sealing agent to the thread of the body.

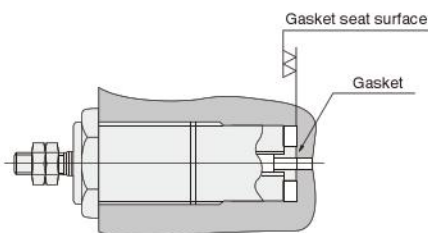

Sensor switches

Double acting type

● Setting the head side stroke end

- Push piston rod to the fully retracted position.
- Install a sensor switch in a holder without tightening a mounting screw all the way, move the switch from head side to rod side until it turns ON (for **ZC130**, **ZC153**, **CS11T**, when the LED lights up), then move the switch 1 notch (= 1mm [0.039in.]) for **ZC130** and **ZC153**, or 2 notches (= 2mm [0.079in.]) for **CS5T** and **CS11T** toward the rod side, and tighten the mounting screw.

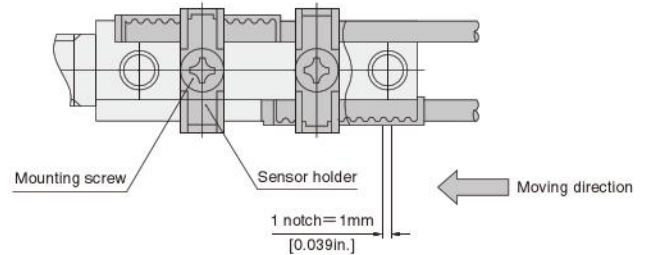

● Setting the rod side stroke end

Conduct the same procedure as the head side, but on the reversed way.

- Pull piston rod to the fully extended position.
- Install a sensor switch in a holder without tightening a mounting screw all the way, move the switch from rod side to head side until it turns ON, then move the switch 1 notch (=1mm [0.039in.]) for **ZC130**, **ZC153**, or 2 notches (=2mm [0.079in.]) for **CS5T** and **CS11T** toward head side and tighten the mounting screw.

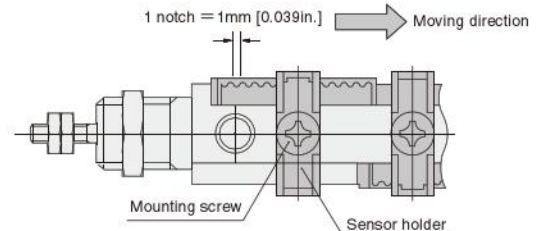

Caution when installing cylinder with sensor switch

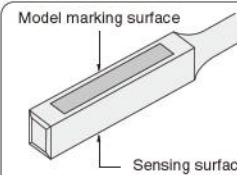

In the ZC type sensor switches, the opposite side from the model marking surface is the sensing surface side. Mount it so that the cylinder magnet comes to the sensing surface side.

When installing 2 or more knock cylinders with magnets, which are located close to each other in parallel, follow the conditions shown below.

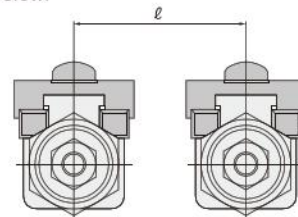

Bore size	ℓ dimension
6 [0.236in.]	23mm [0.906in.] or more
10 [0.394in.]	24mm [0.945in.] or more
16 [0.630in.]	26mm [1.024in.] or more