



CAD drawing data catalog
is available.



KOGANEI

ACTUATORS GENERAL CATALOG

MULTI SLIDERS CONTENTS

Features	923
Handling Instructions and Precautions	925
Specifications	929
Order Codes	930
Inner Construction	931
Dimensions	932
Sensor Switches	936

MULTI SLIDERS

Discontinued



Caution

Before use, be sure to read the "Safety Precautions" on p. 57.

Vertical or horizontal mounting! The “thin” body design is suitable for special mounting applications.

Multi Sliders

- Bore size: $\phi 6$ [0.236in.], $\phi 10$ [0.394in.], $\phi 16$ [0.630in.], $\phi 20$ [0.787in.]
- Linear guides to ensure accuracy during table movement

Suitable for mounting workpieces on 3 surfaces

- Choice of 3 mounting surfaces for workpieces reduces design limitations.

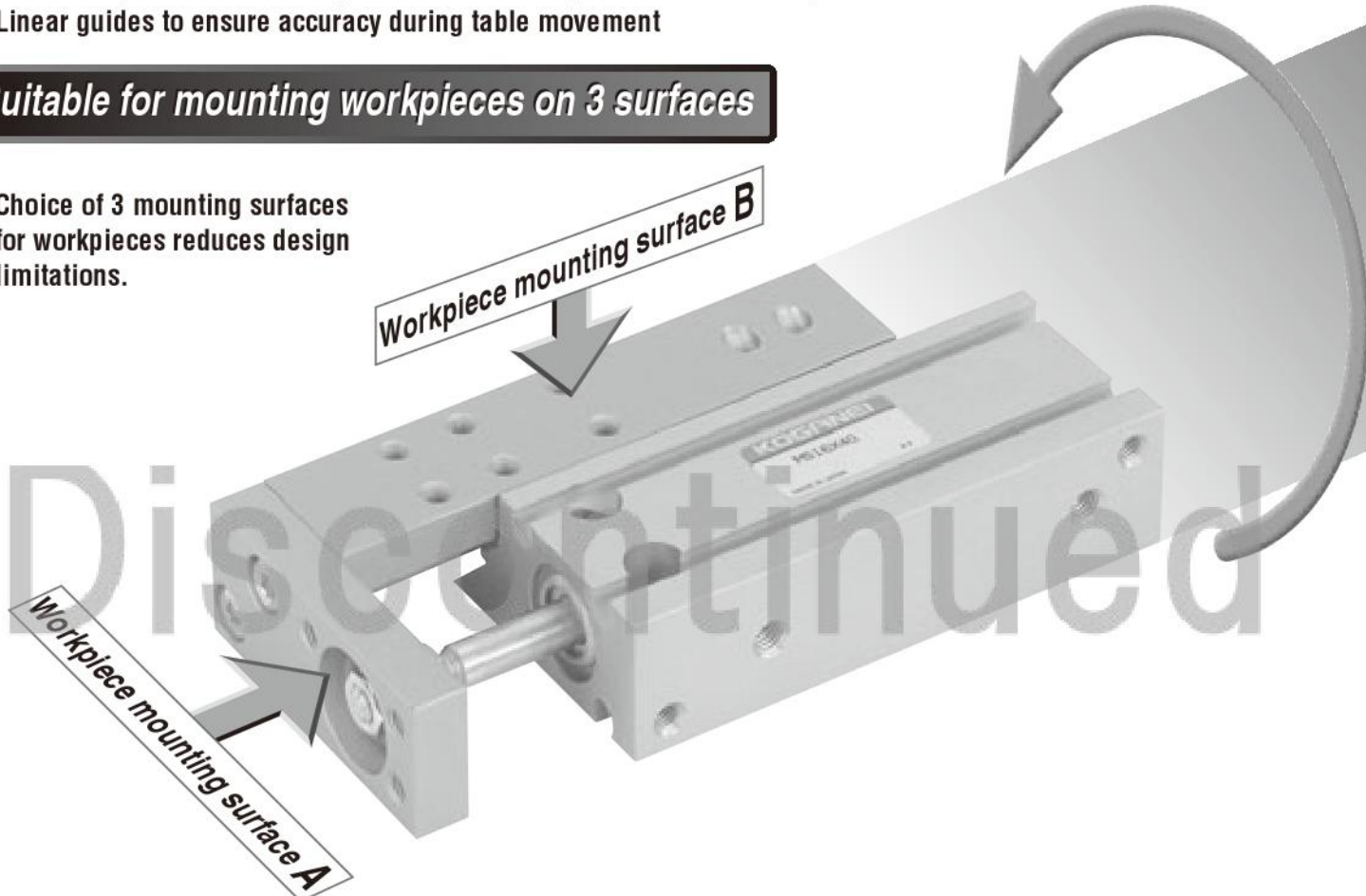

Ultra-thin body!

- A compact body achieves an ultra-thin profile.

(Viewed from workpiece mounting surface A)

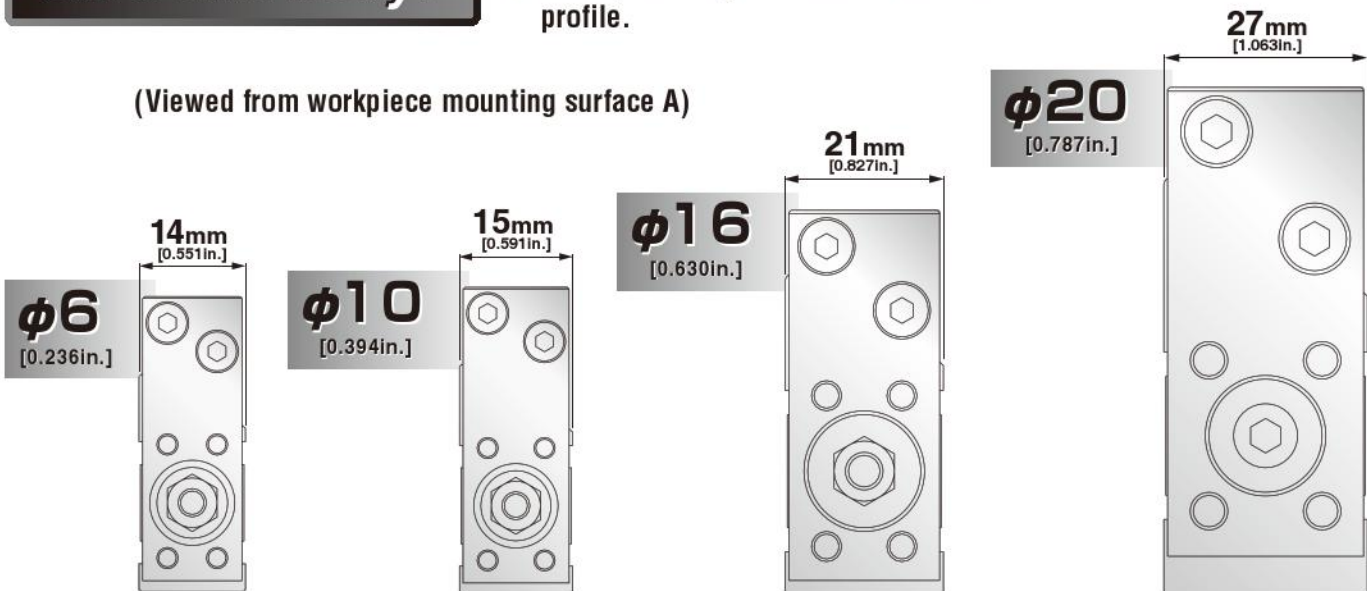

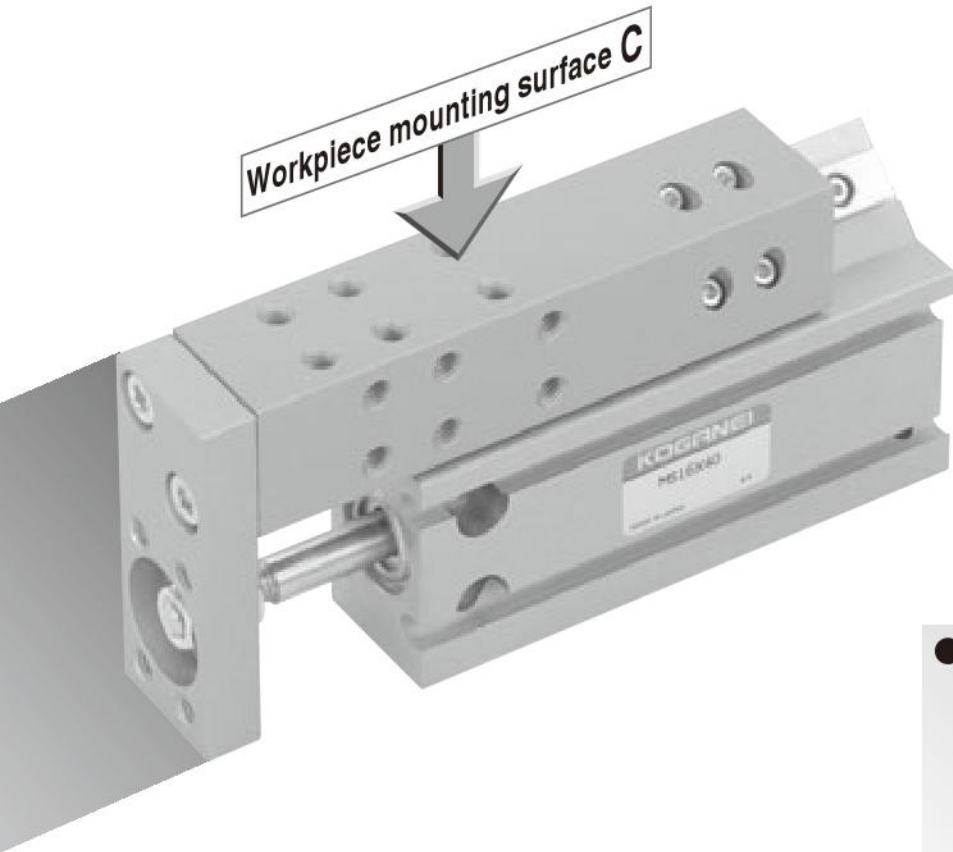

● Stroke Table

	10	20	30	40	50	60
φ6	●	●	●	●	●	●
φ10	●	●	●	●	●	●
φ16	●	●	●	●	●	●
φ20	●	●	●	●	●	●

Linear guide



Embedded sensor switches

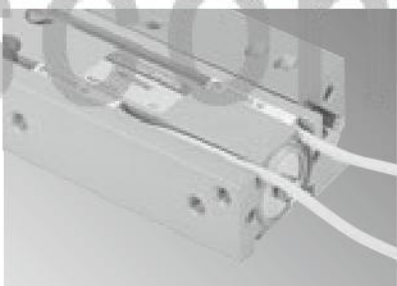

We use embedded sensor switches and lead wires that give a clean cylinder profile.

Pipe connection on a single surface

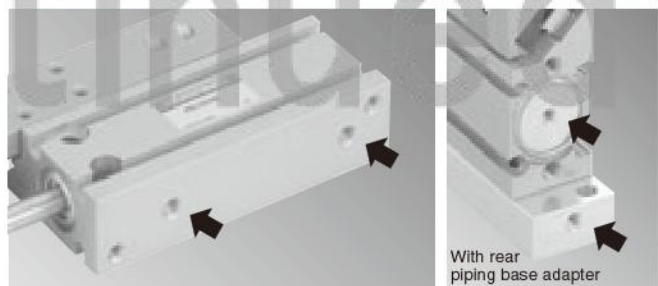

Concentrating the piping on a single plane offers space savings. An optional rear piping base adapter is also available.

Four types of body installations are possible

Vertical mounting using body threads

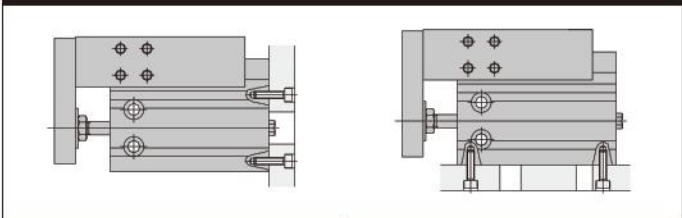

Horizontal mounting using through holes **Vertical mounting using rear piping base adapter**

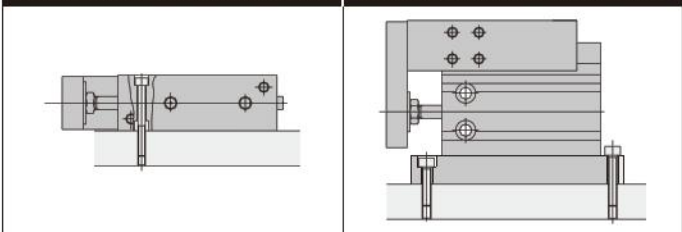

Suitable for close-pitch mounting!

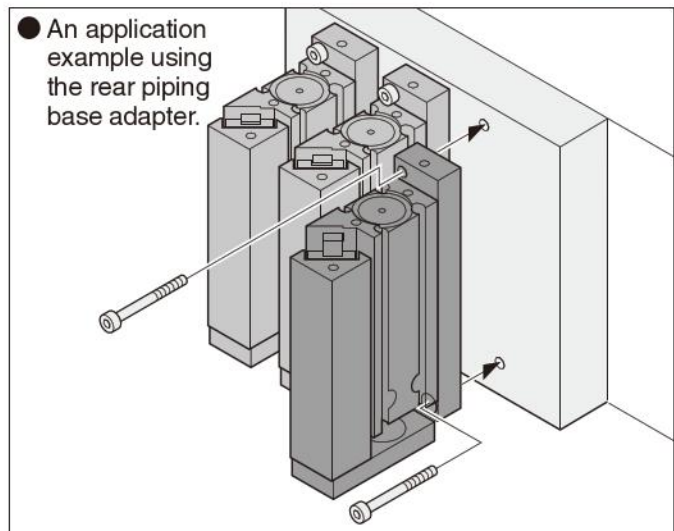

Handling Instructions and Precautions



General precautions

Piping

1. Always thoroughly blow off (use compressed air) the tubing before connecting it to the Multi Slider. Entering chips, sealing tape, rust, etc., generated during piping work could result in air leaks or other defective operation.
2. When connecting piping or fittings to the Multi Slider, tighten them to the following tightening torques.

Connecting thread	Tightening torque N·m [ft·lbf]
M3×0.5	0.29 [0.21]
M5×0.8	1.37 [1.01]

Media

1. Use air for the media. For the use of any other media, consult us.
2. Air used for the cylinder should be clean air that contains no deteriorated compressor oil, etc. Install an air filter (filtration of a minimum 40 μm) near the cylinder or valve to remove collected liquid or dust. In addition, drain the air filter periodically.
Collected liquid or dust entering the cylinder may cause improper operation.

Lubrication

The product can be used without lubrication, if lubrication is required, use Turbine Oil Class 1 (ISO VG32) or equivalent. Avoid using spindle oil or machine oil.

Atmosphere

If using in locations subject to dripping water, dripping oil, etc., or to large amounts of dust, use a cover to protect the unit.

Handling Instructions and Precautions

Multi Slider allowable bending moment

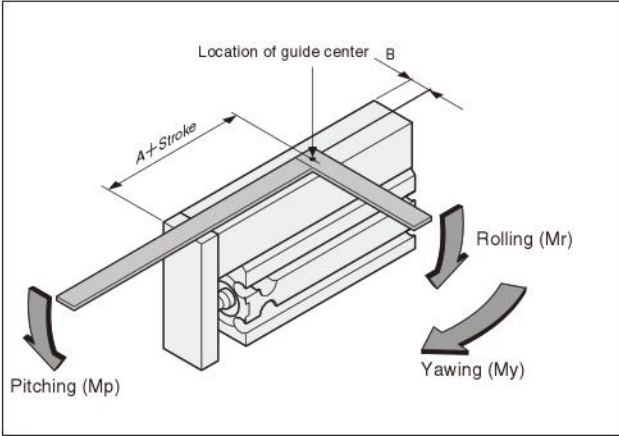

● Use the location of guide center in the diagram as the datum point for determining the moment center.

Allowable bending moment

N · m [ft · lbf]

Bore size mm [in.]	Allowable bending moment	Mp (Pitching)	Mr (Rolling)	My (Yawing)
6 [0.236]		0.36 [0.27]	0.49 [0.36]	0.52 [0.38]
10 [0.394]		0.36 [0.27]	0.49 [0.36]	0.52 [0.38]
16 [0.630]		0.45 [0.33]	1.02 [0.75]	0.45 [0.33]
20 [0.787]		0.91 [0.67]	2.08 [1.53]	0.91 [0.67]

Distance correction value for moment center

mm [in.]

Bore size mm [in.]	Code	A	B
6 [0.236]		28.5 [1.122]	8.5 [0.335]
10 [0.394]		30 [1.181]	9 [0.354]
16 [0.630]		39 [1.535]	11 [0.433]
20 [0.787]		49 [1.929]	14 [0.551]

Formulas for calculating allowable load Fp, Fy, Fr

Pitching moment

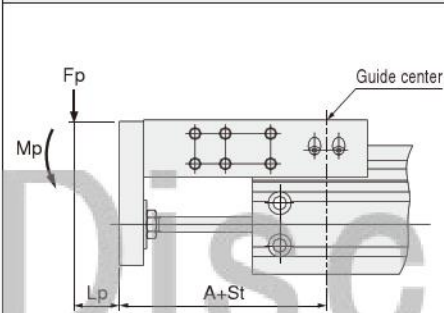

$$F_p = \frac{M_p \times 1000}{L_p + (A + St)} \text{ (N)}$$

Lp: Distance from plate to loading point (mm)

A + St: Distance from plate to guide center (mm)

(For A, use the distance correction value for the moment center above.)

St: Cylinder stroke (mm)

$$F'_p = \frac{M_p \times 12}{L'_p + (A + St')} \text{ [lbf.]}$$

Mp: Allowable bending moment [ft · lbf]

L'p: Distance from plate to loading point [in.]

A + St': Distance from plate to guide center [in.]

(For A, use the distance correction value for the moment center above.)

St': Cylinder stroke [in.]

Yawing moment

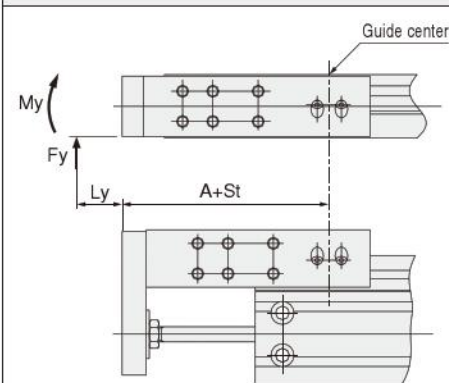

$$F_y = \frac{M_y \times 1000}{L_y + (A + St)} \text{ (N)}$$

Ly: Distance from plate to loading point (mm)

A + St: Distance from plate to guide center (mm)

(For A, use the distance correction value for the moment center above.)

St: Cylinder stroke (mm)

$$F'_y = \frac{M_y \times 12}{L'_y + (A + St')} \text{ [lbf.]}$$

My: Allowable bending moment [ft · lbf]

L'y: Distance from plate to loading point [in.]

A + St': Distance from plate to guide center [in.]

(For A, use the distance correction value for the moment center above.)

St': Cylinder stroke [in.]

Rolling moment

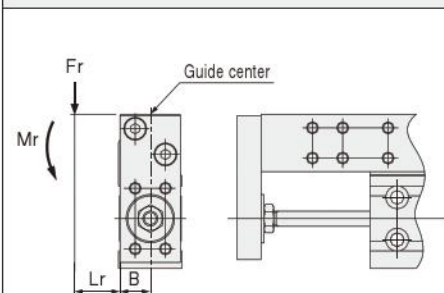

$$F_r = \frac{M_r \times 1000}{L_r + B} \text{ (N)}$$

Lr: Distance from plate to loading point (mm)

B: Distance to guide center (mm)

(For B, use the distance correction value for the moment center above.)

$$F'_r = \frac{M_r \times 12}{L'_r + B} \text{ [lbf.]}$$

Mr: Allowable bending moment [ft · lbf]

L'r: Distance from plate to loading point [in.]

B: Distance to guide center [in.]

(For B, use the distance correction value for the moment center above.)

Handling Instructions and Precautions

Mounting guidelines for rear piping base adapter

For the Multi Slider with rear piping base adapter, use the following guidelines to mount and assemble to use the rear piping base adapter as it is included at shipping but not assembled.

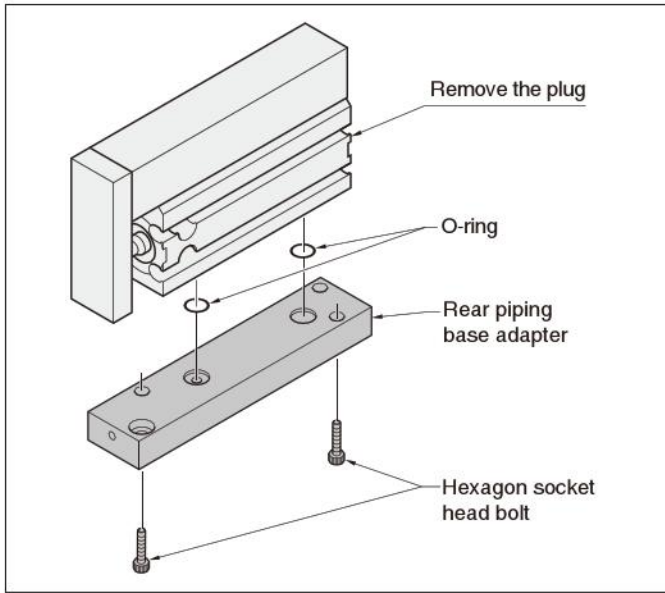

1. Remove the plug on the head cover.
(When remounting the plug, tighten with a torque of $0.59\text{N} \cdot \text{m}$ [$0.44\text{ft} \cdot \text{lb}$].)
2. Set the O-rings provided as shown in the diagram, and use the hexagon socket head bolts provided to mount the adapter. Tighten with the torque shown in the table below.

Bore size mm [in.]	Hexagon socket head bolt	Mounting torque $\text{N} \cdot \text{m}$ [ft · lbf]
6, 10 [0.236, 0.394]	M3×0.5	1.08 [0.80]
16 [0.630]	M4×0.7	2.45 [1.81]
20 [0.787]	M5×0.8	5.10 [3.76]

Allowable kinetic energy

Use the Multi Slider within the ranges of allowable kinetic energy shown in the table below.

If the kinetic energy exceeds the range, either reduce piston speed, or lighten the load mass.

Bore size mm [in.]	Allowable kinetic energy J [ft · lbf]
6 [0.236]	0.007 [0.005]
10 [0.394]	0.018 [0.013]
16 [0.630]	0.031 [0.023]
20 [0.787]	0.044 [0.032]

The kinetic energy of loads can be found using the formula below.

$$E_x = \frac{m}{2} v^2$$

E_x : Kinetic energy (J)
 m : Load mass (kg)
 v : Piston speed (m/s)

$$E'_x = \frac{W'}{2g} v'^2$$

E'_x : Kinetic energy [ft·lbf]
 W' : Load weight [lbf.]
 v' : Piston speed [ft./sec.]
 g : Acceleration of gravity 32.2 [ft./sec.²]

Plate eccentricity (reference values)

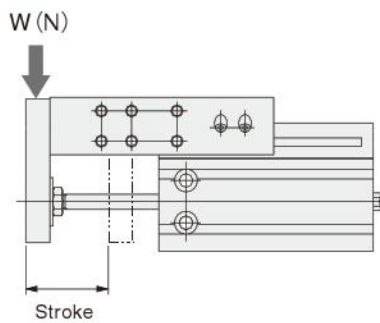

Bore size $\phi 6$ [0.236in.]

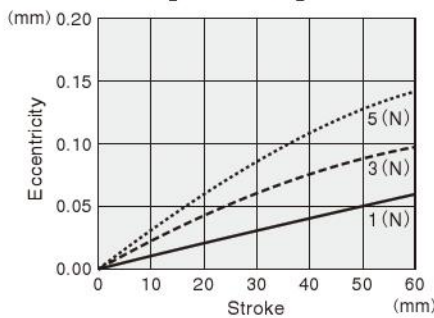

Bore size $\phi 16$ [0.630in.]

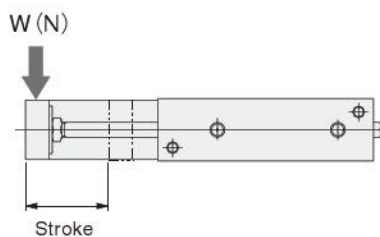
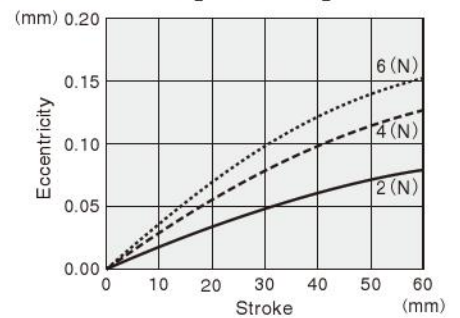

Bore size $\phi 10$ [0.394in.]

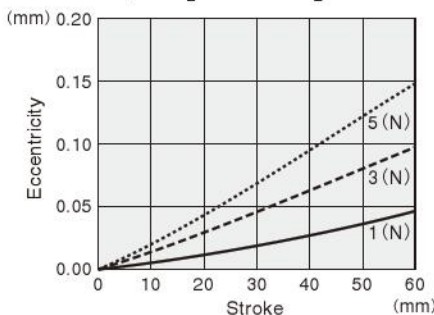

Bore size $\phi 20$ [0.787in.]

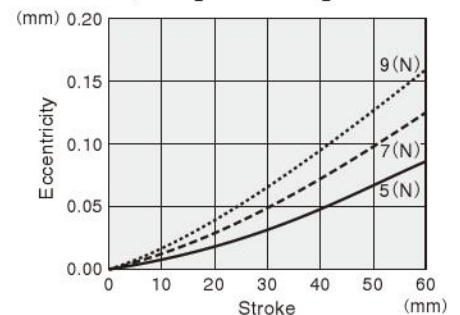

1mm = 0.0394in.



Mounting

1. While any mounting direction is allowed, the mounting surface should always be flat. Twisting or bending during mounting may disturb the accuracy and may also result in air leaks or improper operation.
2. Caution should be exercised that scratches or dents on the Multi Slider's mounting surface may damage its flatness.
3. In applications subject to large shocks, reinforce the bolt mounting, by installing a support to the Multi Slider body, for example, is recommended.
4. Take locking device or anti-looseness measures when shocks or vibrations might loosen the bolts.
5. Do not leave scratches or dents in the areas where the piston rod contacts. It could result in damage to the seal or in air leaks.
6. The piston rod and linear guide are coated with grease. Do not wipe it off, as it may result in improper operation. Apply grease if no lubrication is visible.
(Grease: General purpose lithium soap-based grease No.2)
7. When mounting the Multi Slider, tighten with the torque ranges shown in the table below.

Bore size mm [in.]	Bolt	Tightening torque N · m [ft · lbf]
6, 10 [0.236, 0.394]	M3 × 0.5	1.08 [0.80]
16 [0.630]	M4 × 0.7	2.45 [1.81]
20 [0.787]	M5 × 0.8	5.10 [3.76]

8. If the Multi Slider's thrust is applied to the plate directly, set it so that it is applied at the rod axis center, as shown in the diagram below.

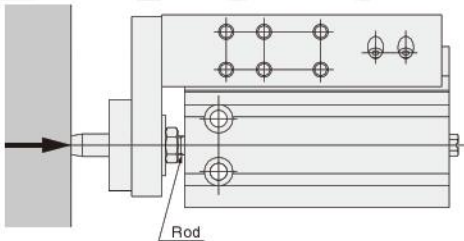

Avoid the application shown below.

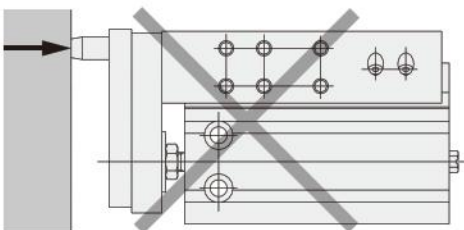

9. Mounting workpieces

Workpieces can be mounted on the Multi Slider on any of the 3 surfaces. Tighten the screws for mounting workpieces with the torque ranges shown below.

Front mounting

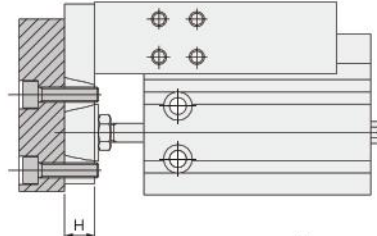

Top mounting

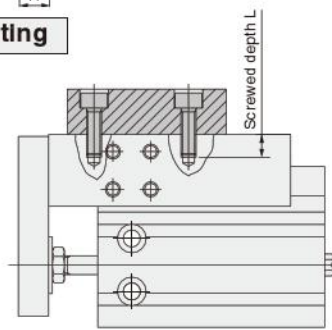

Side mounting

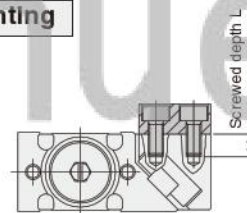

Bore size mm [in.]	Bolt	Maximum tightening torque N · m [ft · lbf]	H mm [in.]	L mm [in.]
6 [0.236]	M3 × 0.5	0.59 [0.44]	5 [0.197]	4 [0.157]
10 [0.394]	M3 × 0.5	0.59 [0.44]	6 [0.236]	4 [0.157]
16 [0.630]	M4 × 0.7	1.37 [1.01]	8 [0.315]	6 [0.236]
20 [0.787]	M5 × 0.8	2.84 [2.09]	10 [0.394]	8 [0.315]

- Cautions:**
1. Since the table is supported by a linear guide, be careful to avoid applying strong shocks or excessive moment when mounting workpieces.
 2. When using bolts, etc., to mount a workpiece to the plate or table, hold the plate and/or table. Tightening while holding the body could apply excessive moment to the guide portion, causing a degradation in accuracy.

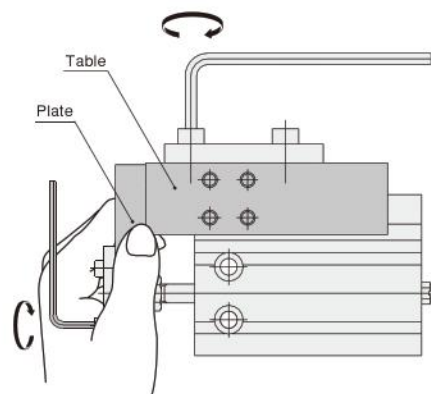

MULTI SLIDERS

Symbol

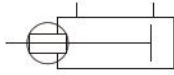

Specifications

Item	Bore mm [in.]	6 [0.26]	10 [0.394]	16 [0.630]	20 [0.787]
Operation type		Double acting type			
Media		Air			
Operating pressure range MPa [psi.]		0.2~0.7 [29~102]	0.15~0.7 [22~102]	0.1~0.7 [15~102]	
Proof pressure MPa [psi.]		1.05 [152]			
Operating temperature range °C [°F]		0~60 [32~140]			
Operating speed range mm/s [in./sec.]		100~500 [3.9~19.7]	50~500 [2.0~19.7]		
Cushion		Rubber bumper			
Lubrication	Cylinder portion	Not required (If lubrication is required, use Turbine Oil Class 1 [ISO VG32] or equivalent.)			
	Linear guide portion	Not required (If lubrication is required, use a lithium soap-based grease.)			
Port size		M5×0.8			
Traveling parallelism	mm [in.]	0.1 [0.0039]			
Allowable moment N·m [ft·lbf]	Pitching	0.36 [0.27]		0.45 [0.33]	0.91 [0.67]
	Rolling	0.49 [0.36]		1.02 [0.75]	2.08 [1.53]
	Yawing	0.52 [0.38]		0.45 [0.33]	0.91 [0.67]

Bore Size and Stroke

Bore size	Standard strokes	Maximum available stroke
6	10, 20, 30, 40, 50, 60	60
10		
16		
20		

Remark: Stroke tolerance $+1 \begin{matrix} +0.039 \\ 0 \end{matrix} \text{in.}$

Cylinder thrust

Bore size mm [in.]	Piston rod diameter mm [in.]	Operation direction	Pressure area mm ² [in. ²]	Air pressure MPa [psi.]						
				0.1 [15]	0.2 [29]	0.3 [44]	0.4 [58]	0.5 [73]	0.6 [87]	0.7 [102]
6 [0.236]	3 [0.118]	Push side	28.2 [0.0437]	—	5.6 [1.26]	8.5 [1.91]	11.3 [2.54]	14.1 [3.17]	16.9 [3.80]	19.7 [4.43]
		Pull side	21.2 [0.0329]	—	4.2 [0.94]	6.4 [1.44]	8.5 [1.91]	10.6 [2.38]	12.7 [2.85]	14.8 [3.33]
10 [0.394]	5 [0.197]	Push side	78.5 [0.1217]	7.9 [1.78]	15.7 [3.53]	23.6 [5.31]	31.4 [7.06]	39.3 [8.83]	47.1 [10.59]	55 [12.36]
		Pull side	58.9 [0.0913]	5.9 [1.33]	11.8 [2.65]	17.7 [3.98]	23.6 [5.31]	29.5 [6.63]	35.3 [7.94]	41.2 [9.26]
16 [0.630]	6 [0.236]	Push side	201 [0.311]	20.1 [4.52]	40.2 [9.04]	60.3 [13.56]	80.4 [18.07]	100.5 [22.59]	120.6 [27.11]	140.7 [31.63]
		Pull side	172 [0.267]	17.2 [3.87]	34.4 [7.73]	51.6 [11.60]	68.8 [15.47]	86 [19.33]	103.2 [23.20]	120.4 [27.07]
20 [0.787]	10 [0.394]	Push side	314 [0.487]	31.4 [7.06]	62.8 [14.12]	94.2 [21.18]	125.6 [28.23]	157 [35.29]	188.4 [42.35]	219.8 [49.41]
		Pull side	235 [0.364]	23.5 [5.28]	47 [10.57]	70.5 [15.85]	94 [21.13]	117.5 [26.41]	141 [31.70]	164.5 [36.98]

Order Codes

MS - -

Bore size
×
Stroke

Number of sensor switches
1 : With 1 sensor switch
2 : With 2 sensor switches
⋮
n : With n sensor switches

Lead wire length
A : 1000mm [39in.]
B : 3000mm [118in.]

Sensor switch
Blank : No sensor switch
ZE101 : Reed switch type, without indicator lamp
ZE102 : Reed switch type, with indicator lamp
ZE201 : Reed switch type, without indicator lamp
ZE202 : Reed switch type, with indicator lamp
ZE135 : 2-lead wire, Solid state type, with indicator lamp
ZE155 : 3-lead wire, Solid state type, with indicator lamp
ZE235 : 2-lead wire, Solid state type, with indicator lamp
ZE255 : 3-lead wire, Solid state type, with indicator lamp
● For details of sensor switches, see p.1544.

Horizontal lead wire DC5~28V, AC85~115V
Horizontal lead wire DC10~28V, AC85~115V
Vertical lead wire^{Note3} DC5~28V, AC85~115V
Vertical lead wire^{Note3} DC10~28V, AC85~115V
Horizontal lead wire DC10~28V
Horizontal lead wire DC4.5~28V
Vertical lead wire^{Note3} DC10~28V
Vertical lead wire^{Note3} DC4.5~28V

Multi slider ^{Note1}

Mounting type
Blank : No rear piping base adapter
L : With rear piping base adapter ^{Note2}

- Notes 1 : Cylinder with magnet is standard.
2 : The rear piping base adapter is included at shipping.
3 : In the vertical lead wire type, the lead wire protrudes at right angles to the sensor switch.

Additional Parts

- Rear piping base adapter (with 2 mounting screws and 2 O-rings)

L-MS

Bore size
×
Stroke

Mass

Model	Stroke						Additional mass of 1 sensor switch	
	10	20	30	40	50	60	ZE□□□A	ZE□□□B
MS 6	62 [2.19]	74 [2.61]	86 [3.03]	98 [3.46]	110 [3.88]	122 [4.30]	15 [0.53]	35 [1.23]
MS10	77 [2.72]	89 [3.14]	101 [3.56]	113 [3.99]	125 [4.41]	137 [4.83]		
MS16	159 [5.61]	182 [6.42]	205 [7.23]	228 [8.04]	251 [8.85]	274 [9.66]		
MS20	331 [11.68]	374 [13.19]	417 [14.71]	460 [16.23]	503 [17.74]	546 [19.26]		

Model	Stroke						Additional mass of 1 sensor switch	
	10	20	30	40	50	60	ZE□□□A	ZE□□□B
MS 6 ×□-L	88 [3.10]	105 [3.70]	122 [4.30]	139 [4.90]	156 [5.50]	173 [6.10]	15 [0.53]	35 [1.23]
MS10 ×□-L	105 [3.70]	121 [4.27]	138 [4.87]	154 [5.43]	170 [6.00]	187 [6.60]		
MS16 ×□-L	205 [7.23]	235 [8.29]	264 [9.31]	294 [10.37]	323 [11.39]	353 [12.45]		
MS20 ×□-L	403 [14.22]	454 [16.01]	505 [17.81]	556 [19.61]	607 [21.41]	658 [23.21]		

Inner Construction

● ϕ 6 [0.236in.]

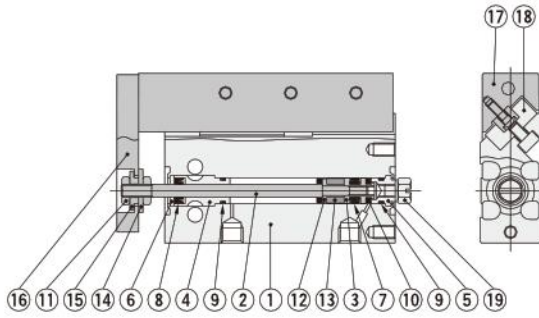

● ϕ 10 [0.394in.]

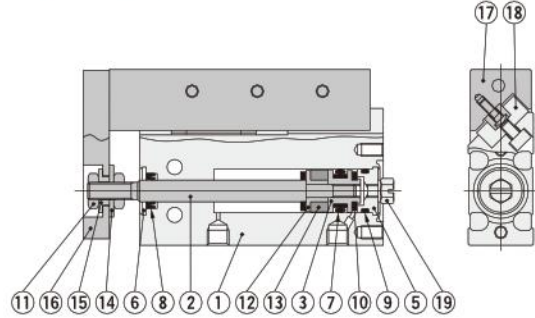

● ϕ 16 [0.630in.]

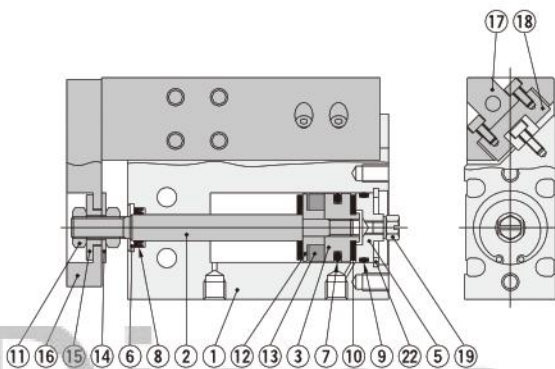

● ϕ 20 [0.787in.]

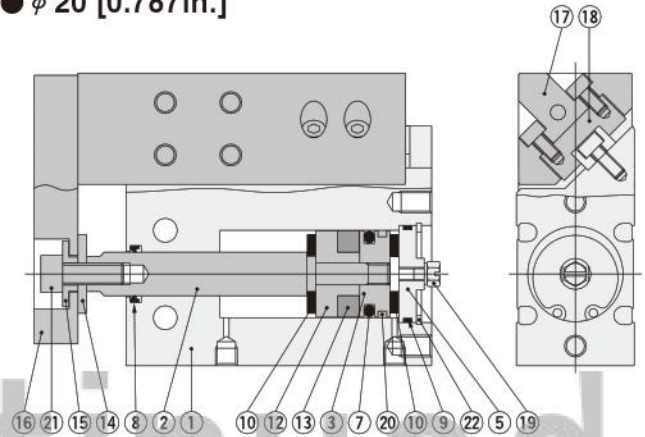

Major Parts and Materials

No.	Parts	Materials
①	Cylinder body	Aluminum alloy (special wear-resistant treatment, only ϕ 6 [0.236in.]: anodized)
②	Piston rod	Stainless steel (only ϕ 20 [0.787in.]: hard chrome plating)
③	Piston	Brass (only ϕ 20 [0.787in.]: Aluminum alloy [special rust prevention treatment])
④	Rod cover	Aluminum alloy (special wear-resistant treatment)
⑤	Head cover	Aluminum alloy (anodized)
⑥	Seal holder	Aluminum alloy (anodized)
⑦	Piston seal	Synthetic rubber (NBR)
⑧	Rod seal	Synthetic rubber (NBR)
⑨	O-ring	Synthetic rubber (NBR)
⑩	Bumper	Synthetic rubber (NBR)
⑪	Rod end nut	Mild steel (nickel plated)
⑫	Support	Brass (only ϕ 20 [0.787in.]: Aluminum alloy [special rust prevention treatment])
⑬	Magnet	Plastic magnet
⑭	Bolt retainer	Steel (nickel plated)
⑮	Spacer	Steel (nickel plated)
⑯	Plate	Aluminum alloy (special wear-resistant treatment)
⑰	Table	Aluminum alloy (special wear-resistant treatment)
⑱	Linear guide	Stainless steel
⑲	Plug	Brass (nickel plated)
⑳	Wear ring	Plastic
㉑	Bolt	Stainless steel
㉒	Snap ring	Steel (nickel plated)

Dimensions (mm)

MS X

CAD $\phi 6$: MS6
 $\phi 10$: MS10

● $\phi 6$, $\phi 10$

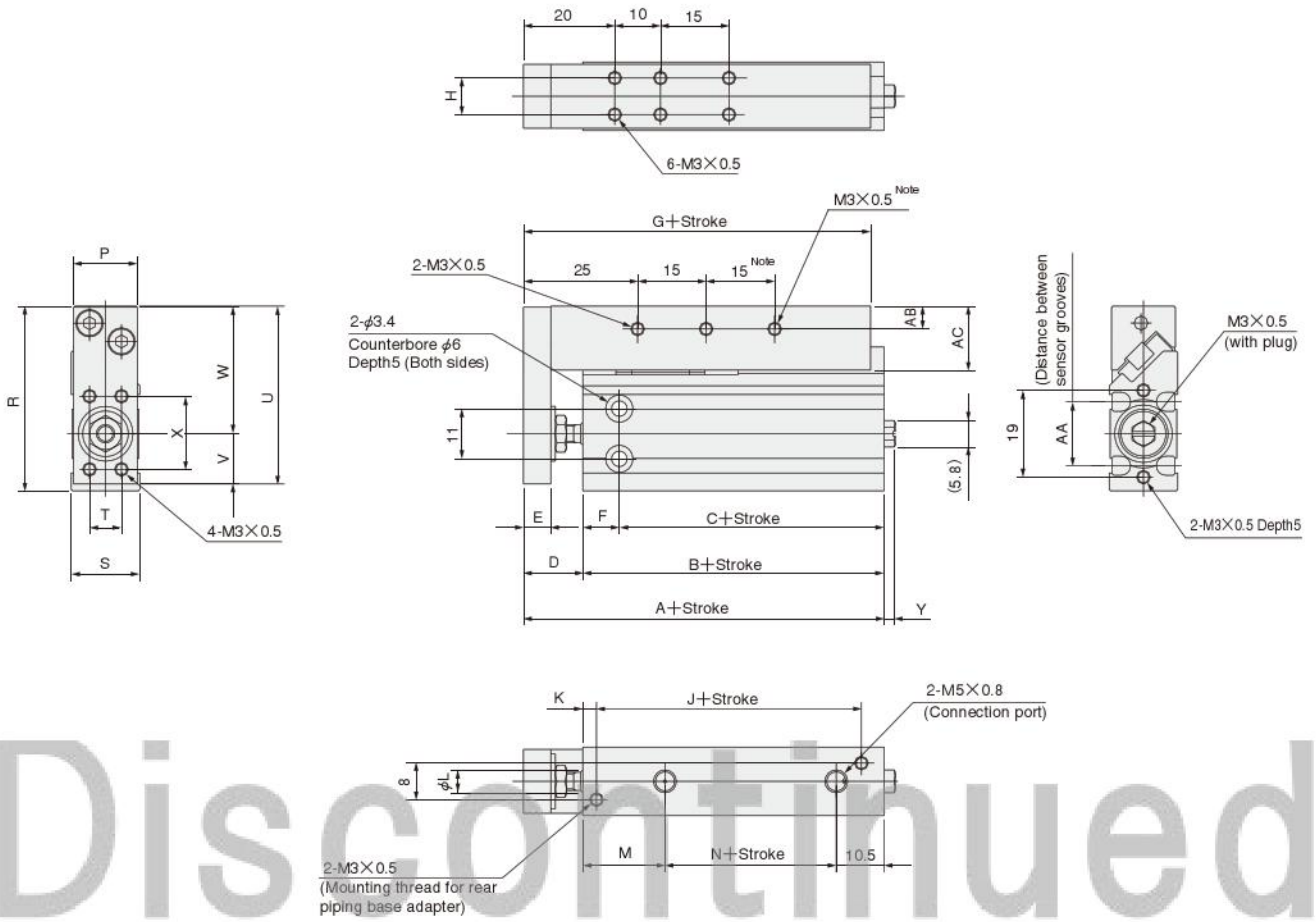

MULTI SLIDERS

Note : This mounting thread is not available for 10mm or less strokes.

Bore size mm [in.] \ Code	A	B	C	D	E	F	G	H	J	K	L	M	N	P	R	S	T	U	V	W	X	Y
6 [0.236]	44	33	26	11	5	7	43.5	6	25.5	2.5	3	15.5	7	13	39	14	6	36.5	9.5	27	14	(3.6)
10 [0.394]	49	36	28	13	6	8	46	8	28	3	5	18	7.5	14	40.5	15	7	39	11	28	16	(2.4)

Bore size mm [in.] \ Code	AA	AB	AC
6 [0.236]	9.2	4.5	13.5
10 [0.394]	14	5	14

Dimensions of Multi Slider with Rear Piping Base Adapter (mm)

MS × -L

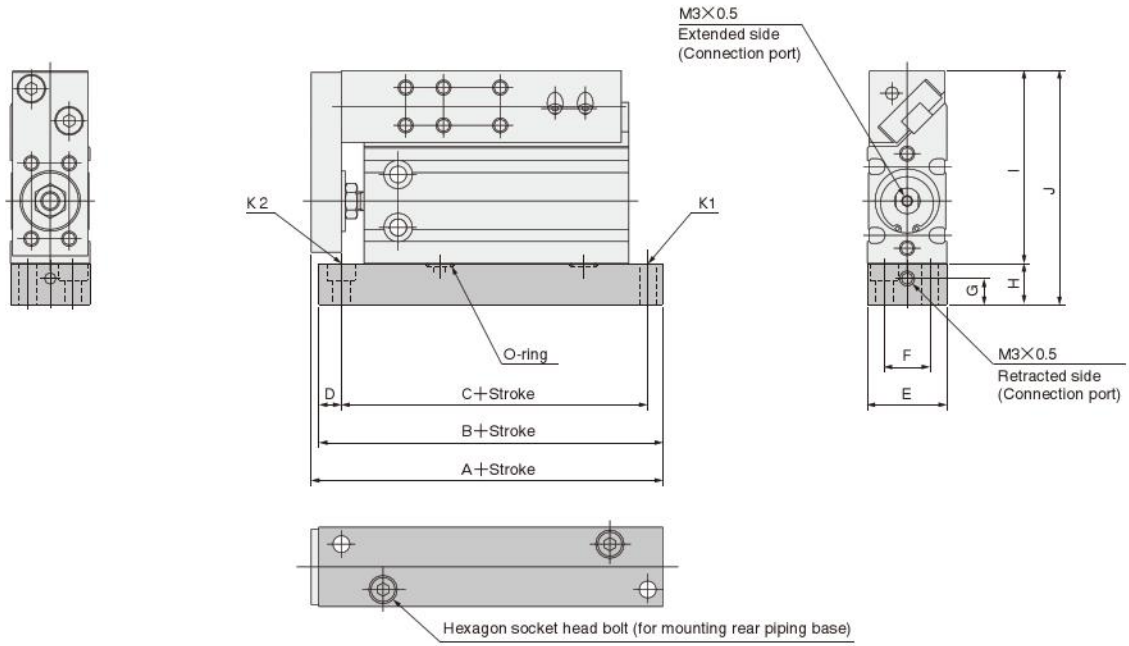

Bore size mm [in.]	Code	A	B	C	D	E	F	G	H	I	J	K1	K2
6 [0.236]		51	49	41	5	15	9	6	10.5	39	49.5	φ 3.4	φ 3.4 Counterbore φ 6 Depth 2.5
10 [0.394]		56	52	44	5	15	9	6	10.5	40.5	51	φ 3.4	φ 3.4 Counterbore φ 6 Depth 2.5
16 [0.630]		63	61	51	6	21	12	7	11	51	62	φ 4.5	φ 4.5 Counterbore φ 7.5 Depth 4.4
20 [0.787]		81	79	64	10	26	15	7	11	67	78	φ 5.5	φ 5.5 Counterbore φ 9.5 Depth 5.4

● Single unit of rear piping base adapter (Additional parts)

L-MS ×

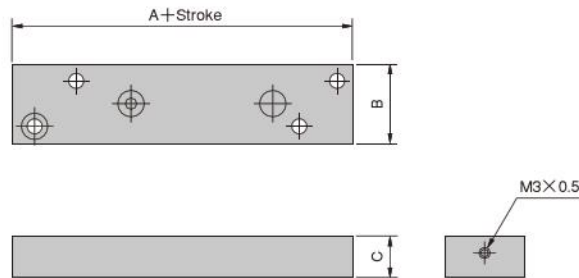

- Included parts
- Mounting screws — 2 pcs.
- O-rings — 2 pcs.

Bore size mm [in.]	Code	A	B	C
6 [0.236]		49	15	10.5
10 [0.394]		52	15	10.5
16 [0.630]		61	21	11
20 [0.787]		79	26	11

SENSOR SWITCHES

Solid State Type, Reed Switch Type

Symbol

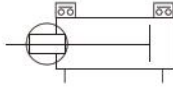

Order Codes

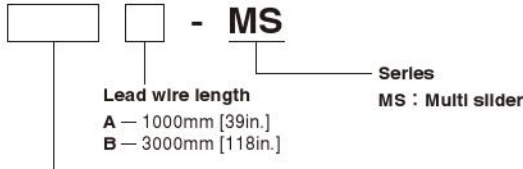

Sensor switch

ZE135 — Solid state type, with indicator lamp	DC10~28V	Horizontal lead wire	ZE155 — Solid state type, with indicator lamp	DC4.5~28V	Horizontal lead wire
ZE235 — Solid state type, with indicator lamp	DC10~28V	Vertical lead wire	ZE255 — Solid state type, with indicator lamp	DC4.5~28V	Vertical lead wire
ZE101 — Reed switch type, without indicator lamp	DC5~28V AC85~115V	Horizontal lead wire	ZE102 — Reed switch type, with indicator lamp	DC10~28V AC85~115V	Horizontal lead wire
ZE201 — Reed switch type, without indicator lamp	DC5~28V AC85~115V	Vertical lead wire	ZE202 — Reed switch type, with indicator lamp	DC10~28V AC85~115V	Vertical lead wire

● For details of sensor switches, see p.1544.

Minimum Cylinder Strokes When Using Sensor Switches

Bore size	Solid state type		Reed switch type	
	2pcs. mounting	1pc. mounting	2pcs. mounting	1pc. mounting
6 [0.236]	5			
10 [0.394]		5	10	5
16 [0.630]	10			
20 [0.787]				

Note: If mounting 2 sensor switches for 5mm strokes at $\phi 16$ and $\phi 20$, consult us.

Moving Sensor Switch

- Loosening the mounting screw allows the sensor switch to be moved along the switch mounting groove of the cylinder body.
- Tighten the mounting screw with a tightening torque of 0.1~0.2N·m [0.9~1.8in·lbf].

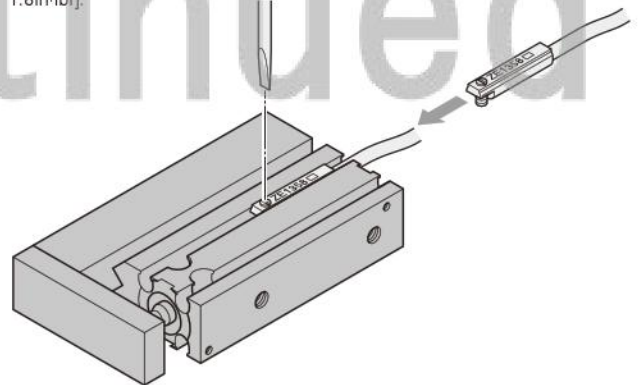

Sensor Switches Operating Range, Response Differential, and Maximum Sensing Location

● Operating range : ℓ

The distance the piston travels in one direction, while the switch is in the ON position.

● Response differential : C

The distance between the point where the piston turns the switch ON and the point where the switch is turned OFF as the piston travels in the opposite direction.

● Solid state type

Item	Bore size	6 [0.236]	10 [0.394]	16 [0.630]	20 [0.787]
Operating range : ℓ		2.1~3.0 [0.083~0.118]	2.6~3.6 [0.102~0.142]	4.0~5.2 [0.157~0.205]	4.0~5.5 [0.157~0.217]
Response differential : C		Max. 1.0 [0.039]			
Maximum sensing location ¹⁾²⁾		6 [0.236]			

Remark: The above table shows reference values.

Note: This is the length measured from the switch's opposite end side to the lead wire.

● Reed switch type

Item	Bore size	6 [0.236]	10 [0.394]	16 [0.630]	20 [0.787]
Operating range : ℓ		4.0~6.8 [0.157~0.268]	5.5~8.4 [0.217~0.331]	6.8~9.8 [0.268~0.386]	5.3~9.8 [0.209~0.386]
Response differential : C		Max. 1.0 [0.039]			
Maximum sensing location ¹⁾²⁾		10 [0.394]			

Remark: The above table shows reference values.

Note: This is the length measured from the switch's opposite end side to the lead wire.

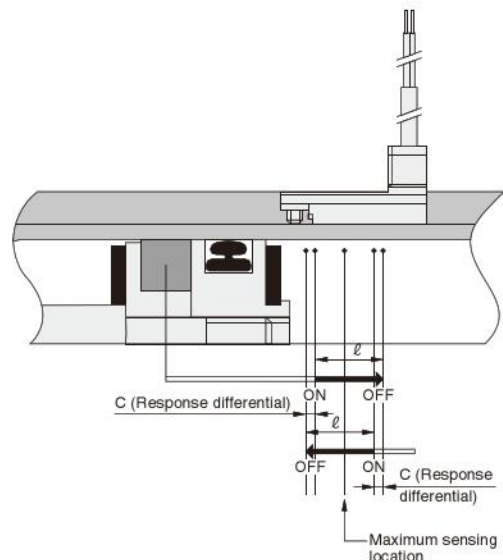

When Mounting Cylinders with Sensor Switches in Close Proximity

When mounting cylinders in close proximity, install the cylinders so that they should not be below the values shown in the following table.

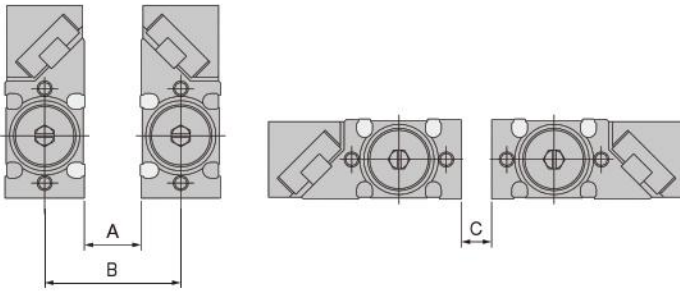

Bore size	mm [in.]		
	A	B	C
6 [0.236]	7 [0.28]	21 [0.83]	0
10 [0.394]	10 [0.39]	25 [0.98]	0
16 [0.630]	14 [0.55]	35 [1.38]	2 [0.08]
20 [0.787]	11 [0.43]	38 [1.50]	0

Mounting Location of End of Stroke Detection Sensor Switch

When the sensor switch is mounted in the locations shown below (the figures in the table are reference values), the magnet comes to the maximum sensing location of the sensor switch at the end of the stroke.

● ZE135, ZE155, ZE101, ZE102

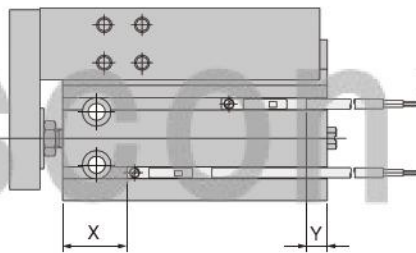

● ZE235, ZE255, ZE201, ZE202

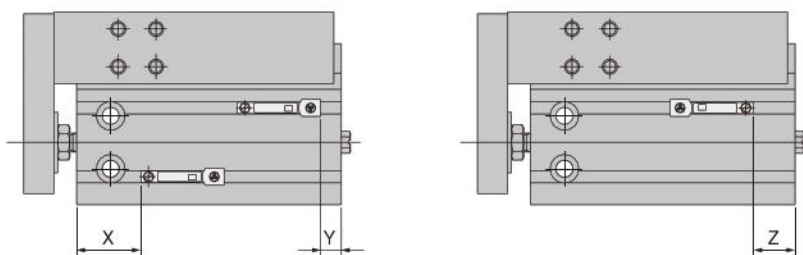

Bore size	ZE135, ZE155, ZE235, ZE255 (Solid state type)			ZE101, ZE102, ZE201, ZE202 (Reed switch type)		
	X	Y	Z	X	Y	Z
6 [0.236]	13 [0.512]	4.5 [0.177]	8 [0.315]	10 [0.394]	1.5 [0.059]	4 [0.157]
10 [0.394]	15 [0.591]	5.5 [0.217]	9 [0.354]	11 [0.433]	2.5 [0.098]	5 [0.197]
16 [0.630]	17 [0.669]	7.5 [0.295]	11 [0.433]	13 [0.512]	4.5 [0.177]	7 [0.276]
20 [0.787]	25 [0.984]	9.5 [0.374]	13 [0.512]	21 [0.827]	6.5 [0.256]	9 [0.354]

Note: Avoid using horizontal lead wire sensor switches at the rod side. The application could cause interfere with the plate and scratch the lead wires.
Use vertical lead wire sensor switches.