

Magnet Type Rodless Cylinders with Integrated Guides

MRB Series

Built-in guide mechanism!
Lightweight → **42% less mass**
Compact! → **36% narrower!**

* MRB10 compared with the previous MRS10

φ10

φ16

New sizes φ20 and φ25 available.



MRB Series

Built-in guide mechanism!
Lightweight, compact, and high-rigidity!

Built-in guide mechanism!

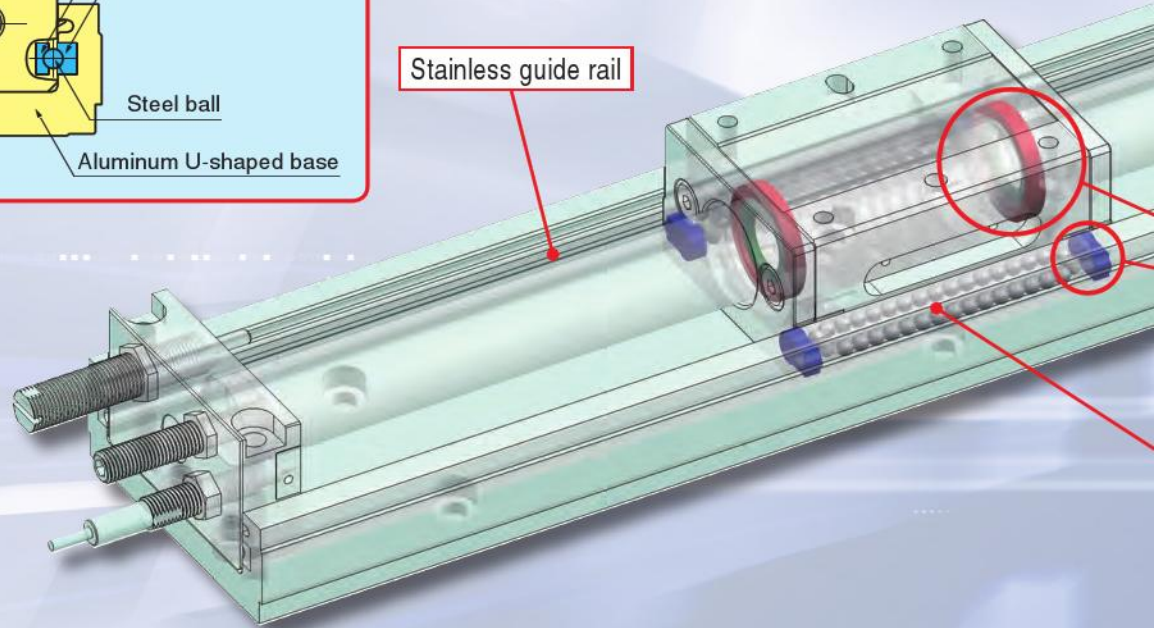
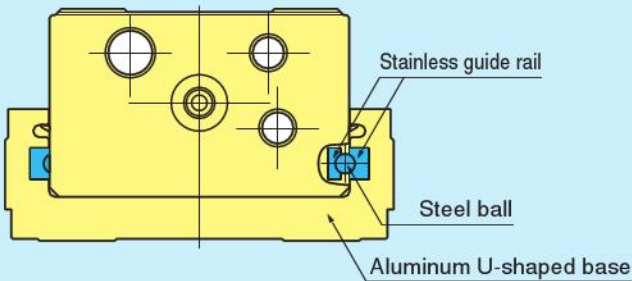

Lightweight!

* Comparison of 500 mm stroke

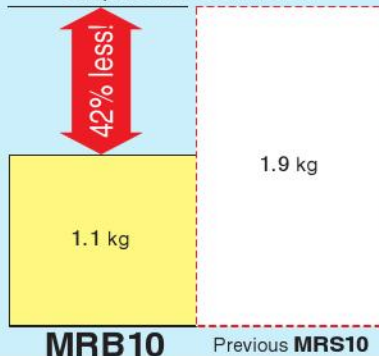

Compact!

Compared with previous product. ↓ Previous **MRS10**

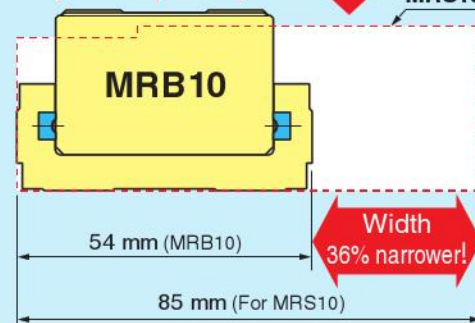

Wide range of speeds

Minimum operating speed: 10 mm/s (30 mm/s for H1 grease type)
 Maximum operating speed: 1000 mm/s
 In addition to stable operation at low speeds, high speed operation of rodless cylinders' advantage is also possible.

H1 grade food processing machinery specifications can also be selected

NSF H1 grade food processing machinery specifications are also available.

A selection of three stopper types

The following types of stoppers are available to suit a range of applications: shock absorber, rubber stopper, and metal stopper.



Shock absorber

Rubber stopper

Metal stopper

Shock absorber and metal stopper can be used together.

Positioning is determined by metal stopper, so misalignment does not occur even when the shock absorber is replaced or adjusted.

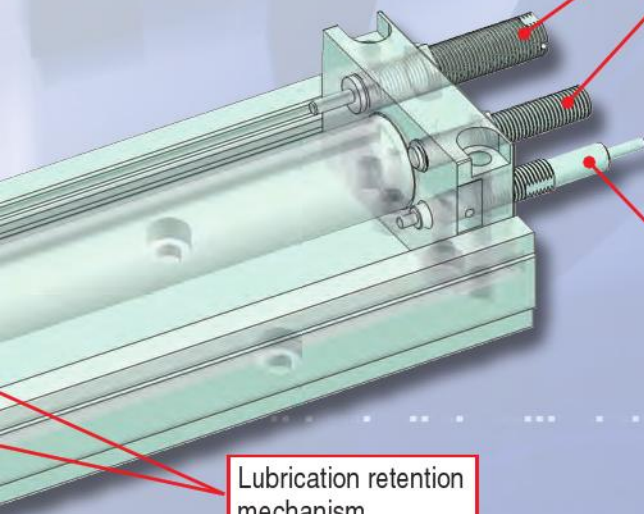
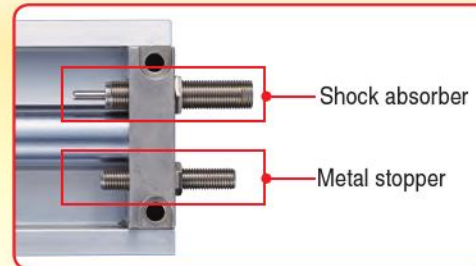

Lubrication retention mechanism

Touch switch mounting supported

A touch switch can be mounted.
 (Metrol CS067A touch switch)
 Enables direct detection of stroke end.
 (Touch switch must be provided by you.)

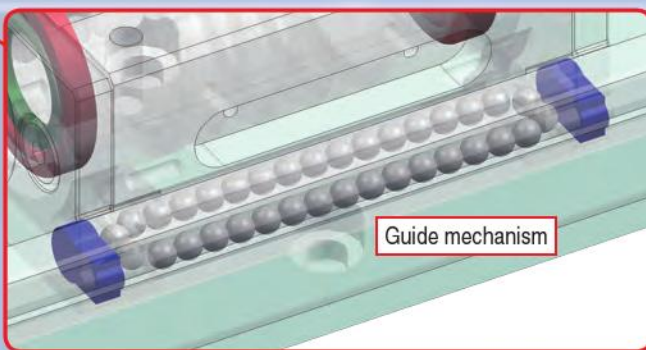

Guide mechanism

Lubrication retention mechanism built into the guide





Keeps cylinder tube and guide rail lubricated to improve durability.

INDEX	Features	1
	Safety Precautions	3
	Handling Instructions and Precautions	3
	Specifications	10

Order Codes	12
Inner Construction and Major Materials	14
Dimensions	15
Sensor Switch	18

Before selecting and using the products, please read all the "Safety Precautions" carefully to ensure proper product use. The Safety Precautions described below are to help you use the product safely and correctly, and to prevent injury or damage to you, other people, and assets. Be sure to observe these safety precautions together with the following safety regulations of ISO4414 (Pneumatic fluid power - General rules and safety requirements for systems and their components), and JIS B 8370 (General rules relating to systems).

The directions are ranked according to degree of potential danger or damage: "DANGER", "WARNING", "CAUTION" and "ATTENTION."

 DANGER	Indicates situations that can be clearly predicted as dangerous. Death or serious injury may result if the situation is not avoided. It could also result in damage or destruction of assets.
 WARNING	Indicates situations that, while not immediately dangerous, could become dangerous. Death or serious injury may result if the situation is not avoided. It could also result in damage or destruction of assets.
 CAUTION	Indicates situations that, while not immediately dangerous, could become dangerous. Failure to avoid the situation creates the risk of minor or semi-serious injury. It could also result in damage or destruction of assets.
 ATTENTION	While there is little chance of injury, this content refers to points that should be observed for appropriate use of the product.

- This product was designed and manufactured for use in general industrial machinery.
- When selecting and handling equipment, the system designer or another person with sufficient knowledge and experience should always read the "Safety Precautions", "catalog", "instruction manual", and other literature before commencing operation. Improper handling is dangerous.
- After reading the instruction manual, catalog, and other documentation, always place them in a location that allows easy availability for reference to users of this product.
- Whenever transferring or lending the product to another person, always attach the catalog, instruction manual, and other information to the product where they are easily visible in order to ensure that the new user can use the product safely and properly.
- The danger, warning and caution items listed under these "Safety Precautions" do not cover all possible contingencies. Read the catalog and instruction manual carefully, and always keep safety first.

DANGER

- Do not use the product for the purposes listed below:
 1. Medical equipment related to maintenance or management of human lives or bodies.
 2. Machines or equipment designed for the purpose of moving or transporting people.
 3. Critical safety components in mechanical devices.
This product has not been planned or designed for purposes that require high levels of safety. Using the product in any of the ways described above creates the risk of loss of human life.
- Do not use the product in locations with or near dangerous substances such as flammable or ignitable substances. This product is not explosion-proof. Doing so creates the risk of ignition or fire.
- When mounting the product and workpiece, always make sure they are firmly supported and secured in place. Falling, dropping, or abnormal operation of the product creates the risk of personal injury.
- Persons using a pacemaker or other similar medical devices should maintain a distance of at least 1 meter away from the product. Getting too close to the product creates the risk of malfunction of a pacemaker due to the strong magnet built into the product.
- Never attempt to modify the product in any way. Doing so creates the risk of injury, electric shock, fire, etc. due to abnormal operations.
- Never attempt inappropriate disassembly, assembly, or repair of the product relating to basic construction, or to its performance or functions.
Doing so creates the risk of injury, electric shock, fire, etc.
- Do not allow water to splash on the product. Water spraying on the product, washing the product, or using the product under water creates the risk of malfunction, leading to injury, electric shock, fire, etc.
- While the product is in operation, avoid touching it with your hands or otherwise approaching too close. Also, do not attempt to make any adjustments to internal or attached mechanism, or to perform any type of adjustment (shock absorber, stroke adjustment mechanism, sensor switch mounting location, piping tube or plug disconnection, etc.) while the product is in operation. This may cause a sudden cylinder movement or any other items that creates the risk of personal injury.
- When operating the product, always install speed controllers, and gradually loosen the needle valve from a choked state to adjust the increase in speed.
Failure to make this adjustment, sudden movements can take place by the air supply, which may cause the loss of human life.

WARNING

- Do not use the product in excess of its specification ranges. Doing so creates the risk of product breakdown, loss of function, or damage. It could also drastically reduce the product's operating life.
- Before supplying air or electricity to the device and before starting operation, always conduct a safety check of the area where the machine is operating. Unintentional supply of air or electricity creates the risk of electric shock or injury due to contact with moving parts.
- Do not touch terminals or switches while power is turned on. Doing so creates the risk of electric shock and abnormal operation.
- Do not allow the product to be thrown into fire. Doing so creates the risk of explosion, resulting in the release of toxic gasses.
- Do not sit on the product, place your foot on it, or place other objects on it.
Doing so creates the risk of injury due to tripping or the product tipping over or dropping, resulting in product damage and abnormal, erratic or runaway operation.
- Before conducting maintenance, inspection, repair, replacement, or any other similar procedure, always completely cut off all air supply and confirm that residual pressure inside the product or in piping connected to the product is zero.
In particular, be aware that residual air will still be in the compressor or storage tank. The cylinder may move abruptly if residual air pressure remains inside the piping, causing injury.
- Do not use the cylinder as a device aiming to absorb the shock or vibration of machinery. Doing so may create the risk of injury or the breakdown of the machinery.
- Do not allow lead wires of sensor switches and other cords to become damaged.
Allowing a cord to become damaged, bent excessively, pulled, rolled up, placed under heavy object, or squeezed between two objects creates the risk of current leaks or defective continuity that can lead to fire, electric shock, or abnormal operation.
- While cylinder is in motion, do not apply external magnetic field to sensor switches. Doing so creates the risk of unintentional movement of the product, resulting in breakdown of equipment or personal injury.
- Abnormally high levels of impact noise and/or vibration can indicate that the shock absorber has reached the end of its service life. Replace the shock absorber.
Continued use creates the risk of product damage, resulting in abnormal operation, runaway operation, etc.

- Use the product within the range of recommended load and specified speed. Using outside the range creates the risk of damaging the cylinder, resulting in the breakdown of the equipment or personal injury.
- Use safety circuits or design a system that prevents damage to machinery and personal injury when the machine is shut down due to an emergency stop or electrical power failure.
- When the pressure is increased by external force, make sure to attach the relief device or any other means not to exceed the specified operating pressure of the cylinder. Pressure exceeding the specified operating pressure may lead to malfunction and breakdown.
- When the machine has been idle for over 48 hours or is in first operation after storage, it is possible that the contacting parts may have become stuck, leading to operation delays or sudden movements. In initial operation, be sure to perform trial operation to check whether the machine works properly.
- Never use the product in direct sunshine-suffered location like beach, near mercury lamp, or near a product likely to produce ozone. Deterioration of rubber parts caused by ozone may reduce the performance and function or stop the function.
- Because KOGANEI products may be used under a wide variety of conditions, decisions concerning conformance with a particular system should be made upon the careful evaluation by the person in charge of system design. Assurances concerning expected system performance and safety are the responsibility of the designer who decides system conformity. Be sure to use the latest catalogs and technical materials to study and evaluate specification details, to consider the possibility of machine breakdown, and to configure a system that ensures fail-safe safety and reliability.
- Do not use in locations that are subject to direct sunlight (ultraviolet rays), in locations with dust, salt, or iron particles, or in locations with media and/or ambient atmosphere that include organic solvents, phosphate ester type hydraulic oil, sulfur dioxide, chlorine gas, acids, etc. Such uses could lead to early shutdown of some functions, a sudden degradation of performance, and a reduced operating life. For details on materials used in the product, refer to the description of materials used in major parts.

CAUTION

- When mounting the product, leave room for adequate working space around it. Failure to do so will make it more difficult to conduct daily inspections or maintenance, which could eventually lead to system shutdown or damage to the product.
- When transporting or mounting a heavy product, firmly support the product using a lift or support, or use multiple people to ensure personal safety.
- Do not bring any magnetic media or memory within 1 meter of the product. Doing so creates the risk of damage to data on the magnetic media due to magnetism.
- The sensor switch should not be used in a location where high current or magnetic field is generated. This may cause the machine to malfunction. Also avoid using magnetic material for any parts used for mounting. Doing so creates the risk of magnetism leakage that causes malfunctions.
- Do not bring the product close to magnetized body. Bringing the product close to magnetized body or the location where high magnetic field is generated can magnetize the main body or table, resulting in the malfunction of sensor switches or defective operation due to attachment of the iron powder.
- Never use non-specified sensor switches with these products. Failure to do so can lead to malfunctions or runaway operations.
- Do not scratch, dent, or deform the actuator by climbing on the product, using it as a scaffold, or placing objects on top of it. Doing so creates the risk of damage to or breakage of the product, resulting in operational shutdown or degraded performance.
- Always post an "operations in progress" sign for installations, adjustments, or other operations, to avoid unintentional supplying of air or electrical power, etc. Unintended power or air supply can cause electric shock or sudden cylinder movement, creating the risk of personal injury.

- Do not apply excessive load to the cords, such as the lead wires of sensor switches mounted on the cylinder, in such manner as pulling, carrying by hands or placing heavy object on the cords. Doing so may cause the leak current or defective continuity, leading to fire, electric shock or malfunctions.
- Using in extremely dry air which dew point exceeds 20 degrees below zero Celsius may affect the quality of the lubricating oil used. This creates the risk of degraded performance, loss of function, or other problems.
- This product uses internal lubrication, and so oil may flow out from pipe ports.

ATTENTION

- Whenever considering use of this product in situations or environments not specifically noted in the "catalog" or "instruction manual", or in applications where safety is an important requirement such as in aircraft facilities, combustion equipment, leisure equipment, safety equipment, and other places where human life or assets may be greatly affected, take adequate safety precautions such as allowing plenty of margin for ratings and performance, or fail-safe measures. Be sure to contact KOGANEI before use in such applications.
- Always check the "catalog" and other reference materials for product wiring and piping.
- Moving parts of machine and devices should be isolated with a protection cover so as not to be directly contacted by human body.
- Do not configure the control system that may cause a workpiece to drop when in power outage. Be sure to configure the work/table-drop prevention control for the case of power outage or emergency stop of the machine.
- When handling the product, wear protective gloves, safety glasses, safety shoes, etc., as required.
- When the product can no longer be used or is no longer necessary, dispose of it appropriately as industrial waste.
- Pneumatic equipment can exhibit degraded performance and function over its operating life. Always conduct daily inspections of the pneumatic equipment, and confirm that all requisite system functions are satisfied, to prevent accidents from happening.
- For inquiries about the product, consult your nearest KOGANEI sales office or KOGANEI overseas department. The addresses and telephone numbers are shown on the back cover of this catalog.

Others

- Always observe the following items. KOGANEI shall not be held responsible for any problems that occur as a result of these items not being properly observed.
 1. When using this product in pneumatic systems, always use genuine KOGANEI parts or compatible products (recommended parts).
When conducting maintenance and repairs, always use genuine KOGANEI parts or compatible products (recommended parts).
Always observe the prescribed methods and procedures.
 2. Never attempt inappropriate disassembly or assembly of the product relating to basic construction, or its performance or functions.

KOGANEI shall not be held responsible for any problems that occur as a result of these safety precautions not being properly observed.



Design and Selection

WARNING

1. Check the specifications.

Using outside of specification range in voltage, current, temperature, shock, etc. creates the risk of breakdown or malfunctions of the product. Read the specifications carefully before using.

2. Avoid mounting cylinders in close proximity to each other

When more than two cylinders with sensor switches are used close to each other, see page 2. This can cause the sensor switch to malfunction due to the magnetic interference with each other.

3. Where the position detection is made at mid-stroke, be cautious against the sensor switch ON time.

Be aware that, when the sensor switch is mounted at intermediate point of cylinder stroke to detect passing of the piston, too fast speed of the piston can shorten the sensor switch operation time, causing the load, such as programmable controllers, to fail to operate.

The highest detectable cylinder speed is

$$V \text{ [mm/s]} = \frac{\text{Sensor switch operating range [mm]}}{\text{Time required for load operation [ms]}} \times 1000$$

4. Keep wiring as short as possible.

The wiring for solid state sensor switches must be 30 m or shorter, as stipulated by EN standard. For reed sensor switches, the longer wiring (10 m or longer) will lead to the larger capacitive surge current, which reduces the operating life of sensor switches. When a longer wiring cannot be avoided, provide the protective circuit described in the catalog.

If the load is inductive or capacitive, provide the appropriate protective circuit as described in the catalog.

5. Avoid repeated bending or excessive pulling of lead wires.

Applying repeated bending or pulling force on the lead wires could cause breaking the wire.

6. Check for leakage current.

2-lead wire solid state sensor switches produce the current (leakage current) even at off condition to activate the internal circuit. Ensure that they satisfy the following inequality:

Input off current of programmable controller > Leakage current

If the above inequality is not satisfied, select 3-lead wire solid state sensor switch. And, if n-pieces sensor switches are connected in parallel, the leakage current increases by n times.

CAUTION

1. Check for internal voltage drop of sensor switches.

When reed sensor switches with indicator lamps or 2-lead wire solid state sensor switches are connected in series causes increasing internal voltage drop, and the load may fail to activate. Connecting n-pieces will drop the internal voltage by n times as large.

Ensure the circuit satisfy the following inequality.

Power supply voltage — Internal voltage drop × n > Minimum operating voltage of the load

In relays with rated voltage of less than 24VDC, check to see the above inequality is satisfied even when n = 1.

When the above inequality is not satisfied, select a reed sensor switch without indicator lamp.

2. Do not use Koganei sensor switches with other company's cylinders.

The sensor switches are designed for use with our Koganei cylinders only. Using with other company's cylinders may not function properly.



Installation and adjustment

WARNING

1. Do not apply an external magnetic field to the sensor switch while the cylinder is in operation.

This may cause unintended operation, thereby damaging the device and causing personal injury.

CAUTION

1. Ensure a safe installation environment for the cylinders with sensors.

The sensor switch should not be used in a location where large current or high magnetic field is present. It could result in erratic operation.

Do not use magnetic material for the mounting portion. This may cause erratic operation.

2. Install the sensor switches in the center of their operating range.

Adjust the mounting position of the sensor switch so that the piston can stop in the center of the operating range (the sensor turned-on range). Setting the switch ON the end of the operating range (at the boundary of ON/OFF) may cause the operation to be unstable. Also be aware that the operating range will vary according to the temperature change.

3. Follow the tightening torque for the sensor switches when mounting.

Tightening the screw exceeding the allowable tightening torque may damage the mounting thread, mounting bracket, sensor switch etc. In addition, insufficient tightening torque could cause the sensor switch position to be changed, thereby resulting in unstable operation. For details about tightening torque, refer to Page 2.

4. Do not carry the cylinder by its mounted sensor switch's lead wire.

After mounting a sensor switch on the cylinder, do not carry the cylinder by grabbing the lead wire. This may not only damage the lead wire but also apply stress to the inside of the sensor switch that may damage internal elements, so never perform such behavior.

5. Do not drop the sensor switches or bump them against other objects.

When handling the product, take care to avoid dropping it, allowing it to bump against other objects, or otherwise subjecting it to excessive impact (294.2 m/s² or more).

In the case of reed sensor switches, such behavior may cause the contact to malfunction, thereby giving a signal or turning off the signal instantaneously. And, this may change the contact interval, thereby deteriorating the sensor switch's sensitivity. As such, this may cause the device to malfunction. Even if the sensor switch case is not damaged, the inside of the sensor switch may be damaged, causing erratic operation.

Safety Precautions (Sensor switch)



Wiring

DANGER

1. Prevent nearby moving objects from coming into contact with sensor switches.

When the cylinders equipped with sensor switches are moving, or when moving objects are nearby, do not let them come into contact each other. In particular, lead wires may become worn or damaged causing unstable operation of the sensor switch. In the worst case, this may result in current leakage or electric shock.

2. Always turn off the power before performing wiring work.

Wiring work while the power is on could result in electric shock. Also, incorrect wiring could damage the sensor switch in an instant. Turn on the power after completing the wiring work.

WARNING

1. Check the "catalog" and other reference materials for correct wiring.

Improper wiring could result in abnormal operation.

2. Do not share wiring with power or high voltage lines.

Avoid wiring in parallel to or shared in the same conduit with power line and high-voltage line. Such wiring could cause the sensor switch and control circuit to suffer erratic operation by electric noise.

3. Be cautious against not bending the lead wire repeatedly or applying tension force to the wire.

Applying repeated bending stress or tension force to the lead wire may cause the wire to be broken.

4. Check polarity in the wiring.

For the sensor switch with the polarities (+, -, output) indicated, make sure that wiring connections are correct. The wrong polarities will result in damage to sensor switches.

CAUTION

1. Avoid short circuiting loads.

Turning on the sensor switch while the load is short-circuited causes overcurrent, which will damage the sensor switch in an instant.

Example of short-circuit load: Sensor switch's output lead wire is directly connected to the power supply.

Warranty and General Disclaimer

1. Warranty Period

The warranty period for KOGANEI products is 180 days from the date of delivery.

2. Scope of Warranty and General Disclaimer

- (1) The KOGANEI product warranty covers individual products. When a product purchased from KOGANEI or from an authorized KOGANEI distributor malfunctions during the warranty period in a way that is attributable to KOGANEI responsibility, KOGANEI will repair or replace the product free of charge. Even if a product is still within the warranty period, its durability is determined by its operation cycles and other factors. Contact your nearest KOGANEI sales office or the KOGANEI overseas department for details.
- (2) KOGANEI shall not be held responsible for any losses or for any damage to other machinery caused by breakdown, loss of function, or loss of performance of KOGANEI products.
- (3) KOGANEI shall not be held responsible for any losses due to use or storage of the product in a way that is outside of the product specifications prescribed in KOGANEI catalogs and the instruction manual, and/or due to actions that violate the mounting, installation, adjustment, maintenance and other safety precautions.
- (4) KOGANEI shall not be held responsible for any losses caused by breakdown of the product due to factors outside the responsibility of KOGANEI, including but not limited to fire, natural disaster, the actions of third parties, and intentional actions or errors by you.

Handling Instructions and Precautions



General precautions

Air supply

1. Use air as the medium. For the use of any other media, consult Koganei.
2. Air used for the MRB Series Rodless Cylinder should be clean air that contains no degraded compressor oil, etc. Install an air filter (filtration of 40 μm or less) near the MRB Series Rodless Cylinder or valve to remove dust or accumulated liquid. Also drain the air filter periodically. If liquid or dust gets into the MRB Series Rodless Cylinder, this may cause defective operation.

Piping

1. Before installing piping for the MRB Series Rodless Cylinder, always flush the piping completely by blowing compressed air through it. Machining chips, sealing tape, rust and other debris remaining from the piping work may result in air leaks and malfunctions.
2. When screwing pipes or fittings into the MRB Series Rodless Cylinder, use the appropriate tightening torque shown below:

Connecting thread	Tightening Torque N·m
M5 × 0.8	1.6

Atmosphere

1. Cover the unit when using it in locations where it might be subject to excessive dust, dripping water, dripping oil, etc.
2. This unit cannot be used when medium or ambient atmosphere contains any of the following substances: Organic solvents, phosphoric acid ester type hydraulic oil, sulfur dioxide, chlorine gas, or acids.

Lubrication

The MRB Series Rodless Cylinder does not require lubrication to operate. If lubrication is required, consult us. Do not use turbine oil.

Other precautions

1. The MRB Series Rodless Cylinder may not move smoothly when operated by hand. This is normal since it has been designed to operate with air pressure. Always ensure that cylinder is operated normally by supplying air.
2. MRB Series Rodless Cylinder is equipped with a strong magnet. Do not place magnetic media such as data storage devices and magnetic detection devices within 1 m of this product. Doing so may cause data corruption and malfunction.

Handling Instructions and Precautions



Mounting, stroke adjustment, and piping

Mounting

1. Make sure the flatness of the mounting surface is no greater than 0.02 mm.
Though mounting direction is unrestricted, poor flatness can result in rattling, increased rolling resistance, and shortened service life.
2. Take care to avoid scratching or denting of the base and slider mounting surfaces.
A scratched or dented mounting surface can result in reducing parallelism between mounting surface and slider upper surface.
3. Take care to avoid scratching or denting of the base and slider rail raceway surfaces.
Such conditions can cause rattling and increased rolling resistance.
4. When mounting workpieces, take care to avoid strong impact and excessive moment.
Such conditions can cause rattling and increased rolling resistance.
5. Make sure all of the MRB Series mounting screws are of sufficient strength.
6. In cases where loosening of screws due to impact and/or vibration may be a factor, consider looseness prevention measures, etc.
7. When using cylinder tube and rail raceway surfaces in a location where they are subjected to soiling, periodically clean them. Apply grease to the cylinder tube and rail raceway surfaces after cleaning them.
For information about the type of grease to apply, contact Koganei.
8. Take care to avoid scratching and denting of the cylinder tube.
A scratched or dented cylinder tube can result in erratic operation.
9. The cylinder body equips a strong magnet, so do not use this product in a place where machine oil with magnetic substances or machining chips is present.
10. If an external force larger than the magnetic retaining force is applied and a misalignment or separation of the slider and the piston occurs, return the piston to the end of the stroke and restore the slider to its correct location using external force.

Mounting the Main Unit

1. When mounting the unit, generally tighten mounting screws in the four counterbore holes of the end plate.
2. When accuracy is required at mid-stroke, secure the entire base mounting surface to the mounted surface.
3. When mounting the unit, tighten screws to the torques shown below.

Model	Tightening Torque
MRB10	2.8
MRB16	2.8

Mounting surface

As shown in the figure below, the base side-surface is the reference plane. The reference plane should be used when the cylinder mounting and removal needs to be repeated.

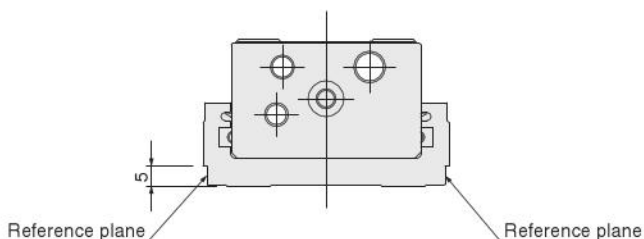

Stroke adjustment

Selecting an optional shock absorber, rubber stopper, or metal stopper allows stroke adjustment within the specification range.

Tighten the lock nut after adjustment.

The stroke adjustment range becomes smaller when a touch switch is used.

Model	Cushion type	L mm
MRB10	Shock absorber	Min. 1 to Max. 10
	Rubber stopper	
	Metal stopper	Min. 1 to Max. 21
	When touch switch used	Min. 1 to Max. 9
MRB16	Shock absorber	Min. 1.5 to Max. 24
	Rubber stopper	
	Metal stopper	Min. 1.5 to Max. 21
	When touch switch used	Min. 1.5 to Max. 9

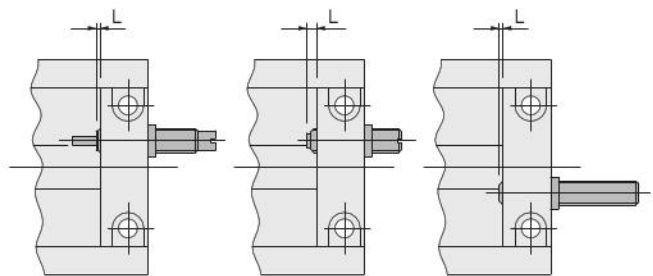

Shock absorber Rubber stopper Metal stopper

When mounting a shock absorber, rubber stopper, or metal stopper, tighten the mounting nut in accordance with the maximum tightening torque guidelines below.

Over-tightening may result in damage to the shock absorber or other components.

Mounting nut maximum tightening torque

Model	Shock absorber Rubber stopper	Metal stopper
MRB10	0.85	0.85
MRB16	2.5	0.85



Selection

Allowable load and moment

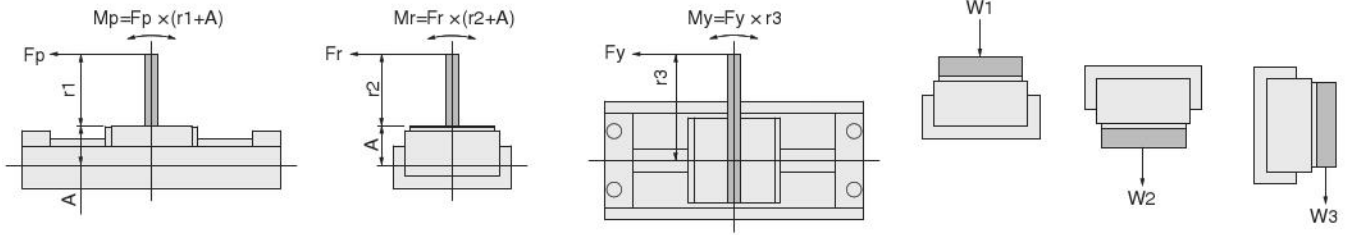

Pitching Moment : $M_p = F_p \times (r_1 + A)$ (N · m)
 Rolling Moment : $M_r = F_r \times (r_2 + A)$ (N · m)
 Yawing Moment : $M_y = F_y \times r_3$ (N · m)
 Maximum load capacity : W_1, W_2, W_3 (N)

Model	A mm
MRB10	21.2
MRB16	24.7

It is possible to apply a load directly on the MRB Series Rodless Cylinder and use it. However, the load and the moment should not exceed the values listed below.

Model \ Load	M_p N · m	M_r N · m	M_y N · m	W_1 N	W_2 N	W_3 N
MRB10	4	8	4		40	
MRB16	6	12	6		90	

Slider displacement by moment

(Reference values)

P-part displacement when each moment is applied.

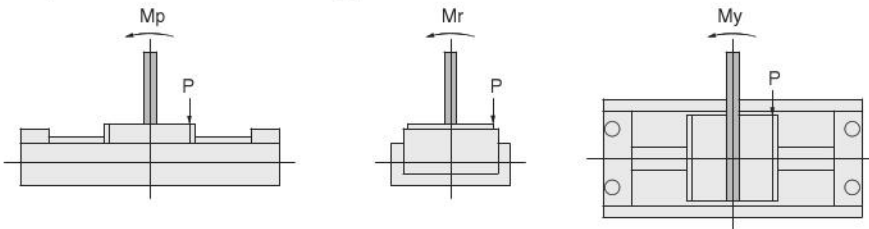

● MRB10

Pitching Moment (M_p)

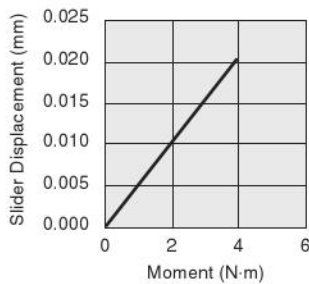

Rolling Moment (M_r)

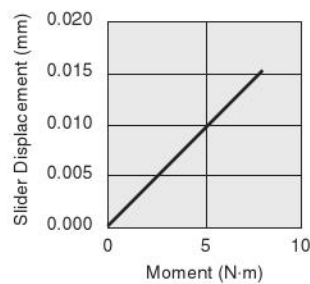

Yawing Moment (M_y)

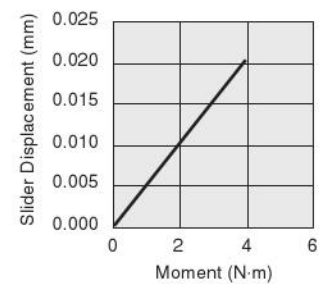

● MRB16

Pitching Moment (M_p)

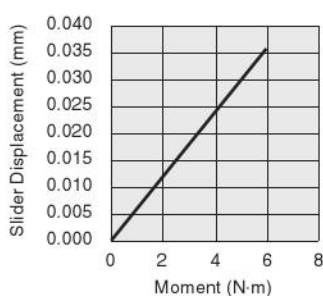

Rolling Moment (M_r)

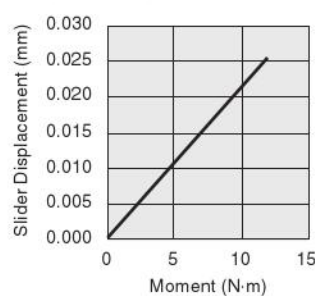

Yawing Moment (M_y)

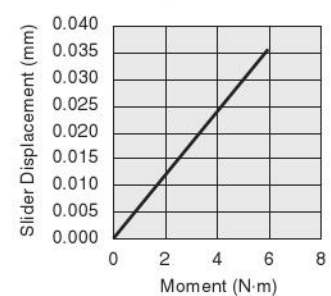

Handling Instructions and Precautions

Cushioning Capacity

Cushioning Capacity diagram

(Horizontal operation at a operating pressure of 0.5 MPa)

● MRB10

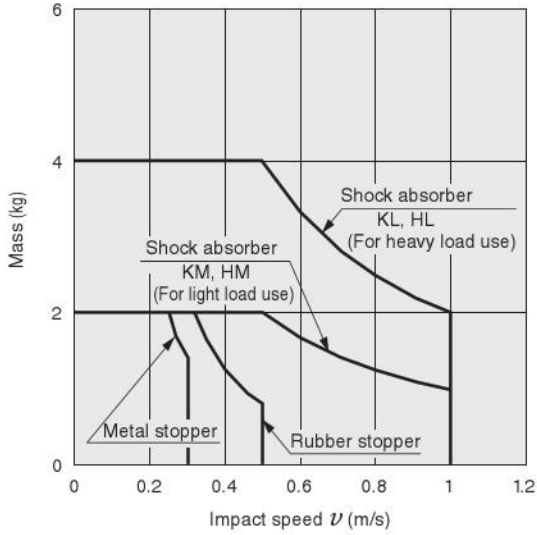

● MRB16

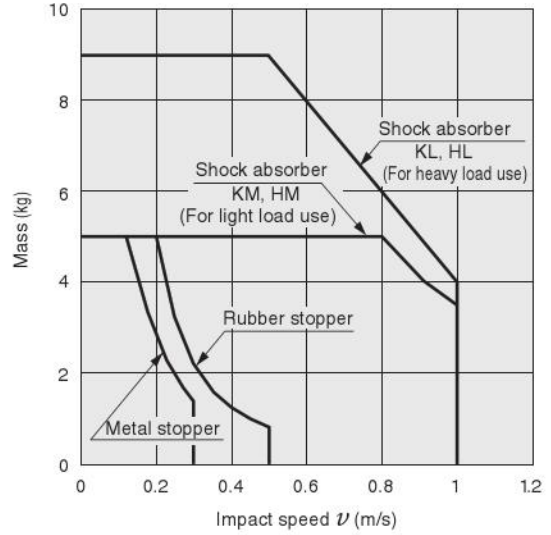

The term "mass" in the graphs refers to the total mass that can be carried by the MRB Series.

"Impact speed" refers to the speed immediately before the cushion is impacted. This is different from the "average speed (cylinder stroke/travel time)."

MRB series

Specifications

Symbol

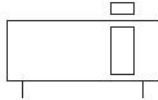

Specifications

Item	Model	MRB10	MRB16	
Cylinder bore	mm	10	16	
Medium		Air ^{Note 1}		
Operating type		Double acting type		
Operating pressure range	MPa	0.2 to 0.7		
Proof pressure	MPa	1.05		
Operating temperature range	°C	0~60		
Operating speed range	mm/s	Shock absorber	10 to 1000 ^{Note 2} (30 to 1000) ^{Note 3}	
		Rubber stopper	10 to 500 ^{Note 2} (30 to 500) ^{Note 3}	
		Metal stopper	10 to 300 ^{Note 2} (30 to 300) ^{Note 3}	
Cushion		Shock absorber		
		Rubber stopper		
		Metal stopper		
Lubrication		Not required ^{Note 4}		
Parallelism ^{Note 5}	mm	0.1		
Stroke adjustment range	mm	Shock absorber	One side 0 to -9	One side 0 to -22.5
		Rubber stopper	One side 0 to -9	One side 0 to -22.5
		Metal stopper	One side 0 to -20	One side 0 to -19.5
		When touch switch used ^{Note 6}	One side 0 to -8	One side 0 to -7.5
Maximum stroke	mm	500		
Maximum payload ^{Note 2}	kg	4	9	
Connection port size		M5 × 0.8		

Note 1: Use clean compressed air that contains no moisture, dust, oxidized oil or other contaminants.

Note 2: For the relationship between the payload and the piston speed, see the Cushioning Capacity diagram on page 9.

Note 3: Values in parentheses are speed ranges for H1 grease specifications.

Note 4: This unit can be used without lubrication. Be sure to contact us if lubrication will be used. Do not use turbine oil.

Note 5: This is the table upper surface parallelism to the unit bottom surface when mounting screws are tightened in all of the end plate and base mounting holes. Different from running parallelism.

Note 6: The stroke adjustment range becomes smaller when a Metrol CS067A touch switch is mounted.

Magnetic Retaining Force

Model	MRB10	MRB16
Magnetic Retaining Force	60	160

Cylinder bore and stroke

Model	Standard stroke
MRB10	50, 100, 150, 200, 250, 300, 350, 400, 450, 500
MRB16	

Note: Contact your nearest Koganei sales office about mid-stroke.

Mass

Model	Zero stroke mass	Additional mass per 1 mm stroke	Option additional mass		
			Shock absorber	Rubber stopper	Metal stopper
MRB10	0.35	0.0014	0.005	0.005	0.007
MRB16	0.54	0.0018	0.0115	0.013	

Additional mass of the sensor rail (sensor rail + magnet set)

Model	Zero stroke mass	Additional mass per 1 mm stroke	Sensor switch ^{Note}	
			1 m lead wire	3 m lead wire
MRB10	0.0135	0.00013	0.015	0.035
MRB16	0.0148			

Note: 0.015 kg in the case of a ZE175G sensor switch

Shock Absorber Specifications

Item	Model	MRB10		MRB16	
		For heavy load (KL, HL)	For light load (KM, HM)	For heavy load (KL, HL)	For light load (KM, HM)
Applicable shock absorber	—	KSHJ6×6-01	KSHJ6×6-02	KSHJ8×8-01	KSHJ8×8-02
	H1 grease specifications	H1-KSHJ6×6-01	H1-KSHJ6×6-02	H1-KSHJ8×8-01	H1-KSHJ8×8-02
Maximum absorption	J	1	0.5	2	
Absorbing stroke	mm	6		8	
Maximum impact speed	m/s	1		1	
Maximum operating frequency	cycle/min	30		90 (H1 grease specifications: 60)	
Maximum absorption per unit of time	J/min	15		60	
Spring return force (at compressed)	N	4		8.6	
Angle variation		1° or less			
Operating temperature range	°C	0 to 60			

Caution: Shock absorber durability differs from the MRB Cylinder depending on how it is used.

Note 1: Use the shock absorber within its capacity range (see the range of the Cushioning Capacity diagram on page 9).

2: The maximum impact speed of the shock absorber is 1 m/s. This differs from the average speed, so do not exceed a speed of 1 m/s at the time of impact.

3: Do not use the shock absorber in locations where it might be exposed to water or oil droplets, or to large amounts of dust. Water, oil, or dust on the piston rod results in damage and decreases service life. Cover the unit when using it in locations where it might be exposed to water or oil droplets, or to large amounts of dust.

4: Do not loosen the lock screw on the end of the shock absorber. Oil will leak out from the unit and lead to decreased functionality of the shock absorber.

5: Do not mount other shock absorbers on this product. The characteristics of each product are different. Use of other shock absorbers may damage the cylinder.

Theoretical Thrust F

Model	Pressure area mm ²	Air pressure MPa					
		0.2	0.3	0.4	0.5	0.6	0.7
MRB10	78.5	16	24	31	39	47	55
MRB16	201	40	60	80	101	121	141

Values in the table are only theoretical. There may be some differences from these in actual applications. When actually selecting a model, consider the W/F ratio of the allowable load (W) in relation to the logical thrust (F). Use the values below as guidelines in accordance with the mounting direction of the MRB Series Cylinder.

● Horizontal mounting

W/F ≤ 10

Use within the cushioning capacity range of each cushion.

● Vertical mounting

Generally W/F ≤ 0.2

Air flow rate and air consumption

Air consumption of the Flat Rodless Cylinder is calculated using the equation below. However, the simplified chart can make the calculations easier.

$$\text{Air flow rate: } Q_1 = \frac{\pi D^2}{4} \times L \times \frac{60}{t} \times \frac{P+0.101}{0.101} \times 10^{-6}$$

Q₁: Air flow rate required for the cylinder

ℓ/min (ANR)

Q₂: Cylinder air consumption

ℓ/min (ANR)

D: Cylinder bore mm

L: Cylinder stroke mm

t: Time needed for the cylinder to travel 1 stroke s

n: Number of cylinder reciprocations per minute cycles/min

P: Operating pressure MPa

Air consumption for every 1 mm of the stroke

Cylinder bore mm	Air pressure MPa					
	0.2	0.3	0.4	0.5	0.6	0.7
10	0.468	0.623	0.779	0.934	1.09	1.245
16	1.198	1.596	1.993	2.391	2.789	3.187

The values in the table are calculated based upon the air flow rate and air consumption at a 1 mm stroke cylinder during 1 reciprocation of the MRB Series Cylinder. Actually required air flow rate and air consumption are calculated with the equations below.

● When calculating air flow rate (When selecting F.R.L., valves, etc.)

Example: For an MRB Series Cylinder with a bore of 10 mm traveling at a speed of 300 mm/s, operating with air pressure of 0.5 MPa

$$0.934 \times \frac{1}{2} \times 300 \times 10^{-3} = 0.140 \text{ ℓ/s (ANR)}$$

(The flow rate every minute is calculated using the equation $0.934 \times \frac{1}{2} \times 300 \times 60 \times 10^{-3} = 8.406 \text{ ℓ/min(ANR)}$)

● When calculating air consumption

Example 1: For an MRB Series Cylinder with a bore size of 10 mm, a stroke of 100 mm, and making 1 reciprocation at an air pressure of 0.5 MPa

$$0.934 \times 100 \times 10^{-3} = 0.093 \text{ ℓ/trip (ANR)}$$

Example 2: For an MRB Series Cylinder with a bore size of 10 mm, a stroke of 100 mm, and making 10 reciprocations per minute at an air pressure of 0.5 MPa.

$$0.934 \times 100 \times 10 \times 10^{-3} = 0.934 \text{ ℓ/min (ANR)}$$

Caution: To calculate the actually required air consumption when using the MRB Series, add the air consumption of the piping to the air consumption derived from the above equations.

Order Codes

●Standard specifications

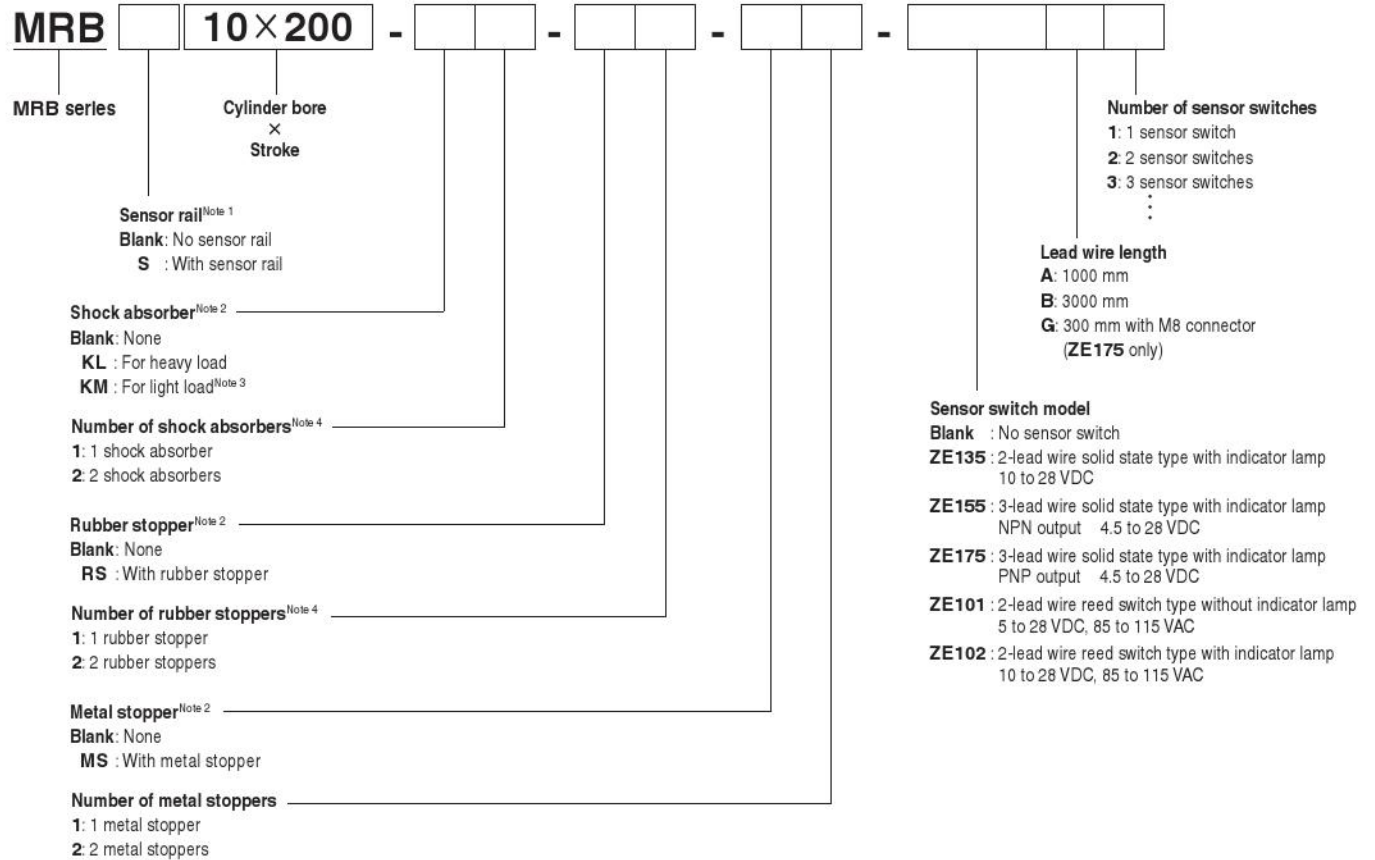

●Food processing machinery use H1 grease specifications

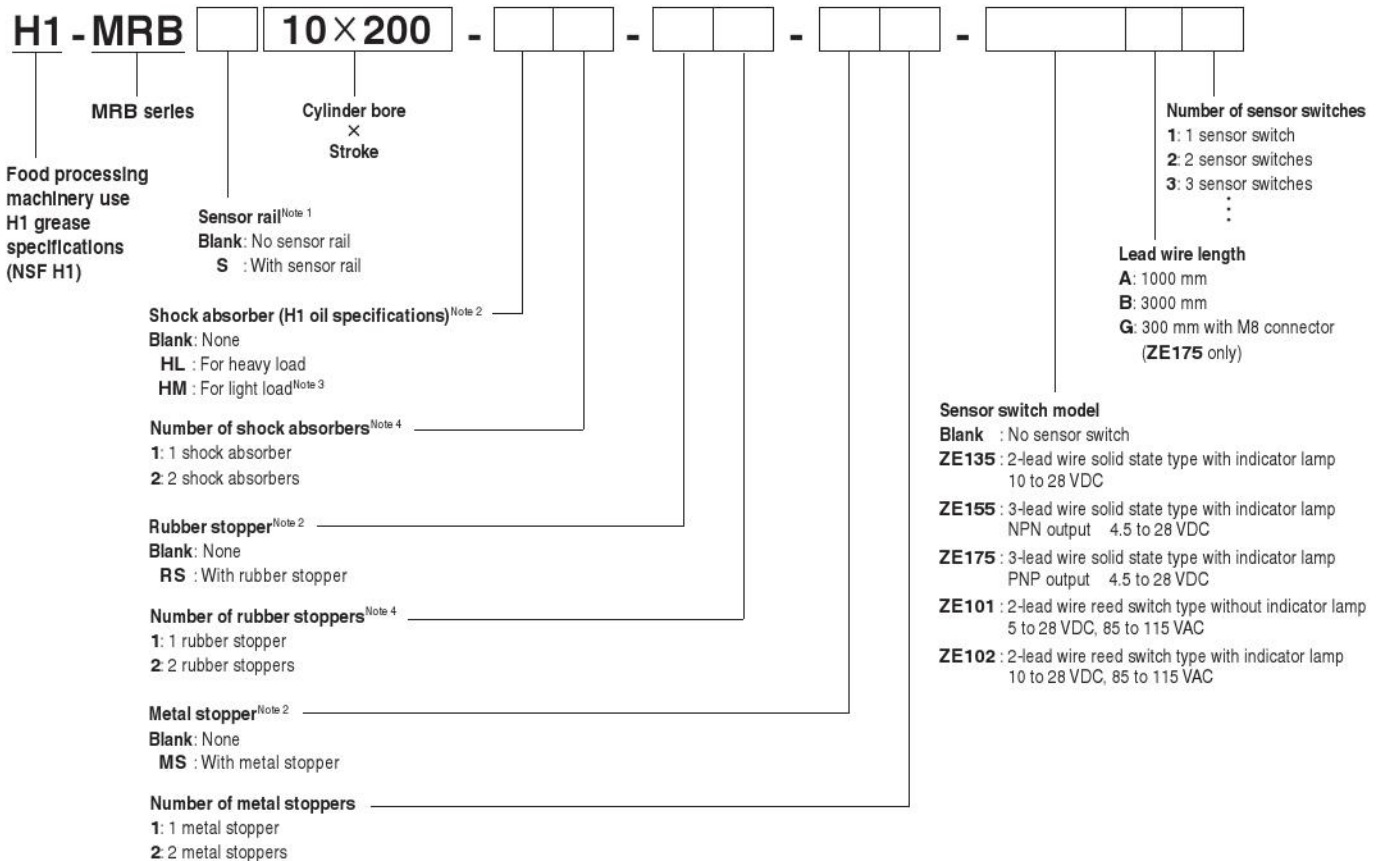

Note 1: A product equipped with a sensor rail, is shipped with the sensor magnet and sensor rail attached to the slider locating pin hole ($\phi 4$) side. For information about mounting the sensor rail to the opposite side, see the sensor rail and sensor magnet mounting information on page 20.
 2: The shock absorber, rubber stopper, and metal stopper are provided with the product.
 3: For light load available upon order.
 4: Up to a combined total of two (shock absorbers or rubber stoppers).

Order Codes

Additional Parts

● Shock absorber

KSHJ

Size

- 6 × 6-01: **MRB10** For heavy load
- 6 × 6-02: **MRB10** For light load
- 8 × 8-01: **MRB16** For heavy load
- 8 × 8-02: **MRB16** For light load

● Rubber stopper

RS-MRB

Cylinder bore

- 10: For **MRB10**
- 16: For **MRB16**

● Metal stopper

MS-MRB

Cylinder bore

- 10: For **MRB10**
- 16: For **MRB16**

Food processing machinery use H1 oil specifications

H1-KSHJ

Size

- 6 × 6-01: **H1-MRB10** For heavy load
- 6 × 6-02: **H1-MRB10** For light load
- 8 × 8-01: **H1-MRB16** For heavy load
- 8 × 8-02: **H1-MRB16** For light load

● Sensor rail

S-MRB ×

Stroke

- 50, 100, 150, 200, 250,
- 300, 350, 400, 450, 500

Cylinder bore

- 10: For **MRB10**
- 16: For **MRB16**

(1 sensor rail, 2 sensor rail mounting screws)

● Sensor magnet set

MG-MRB

Cylinder bore

- 10: For **MRB10**
- 16: For **MRB16**

(1 sensor magnet, 1 magnet holder, 1 shield plate, two magnet holder mounting screws)

Inner construction

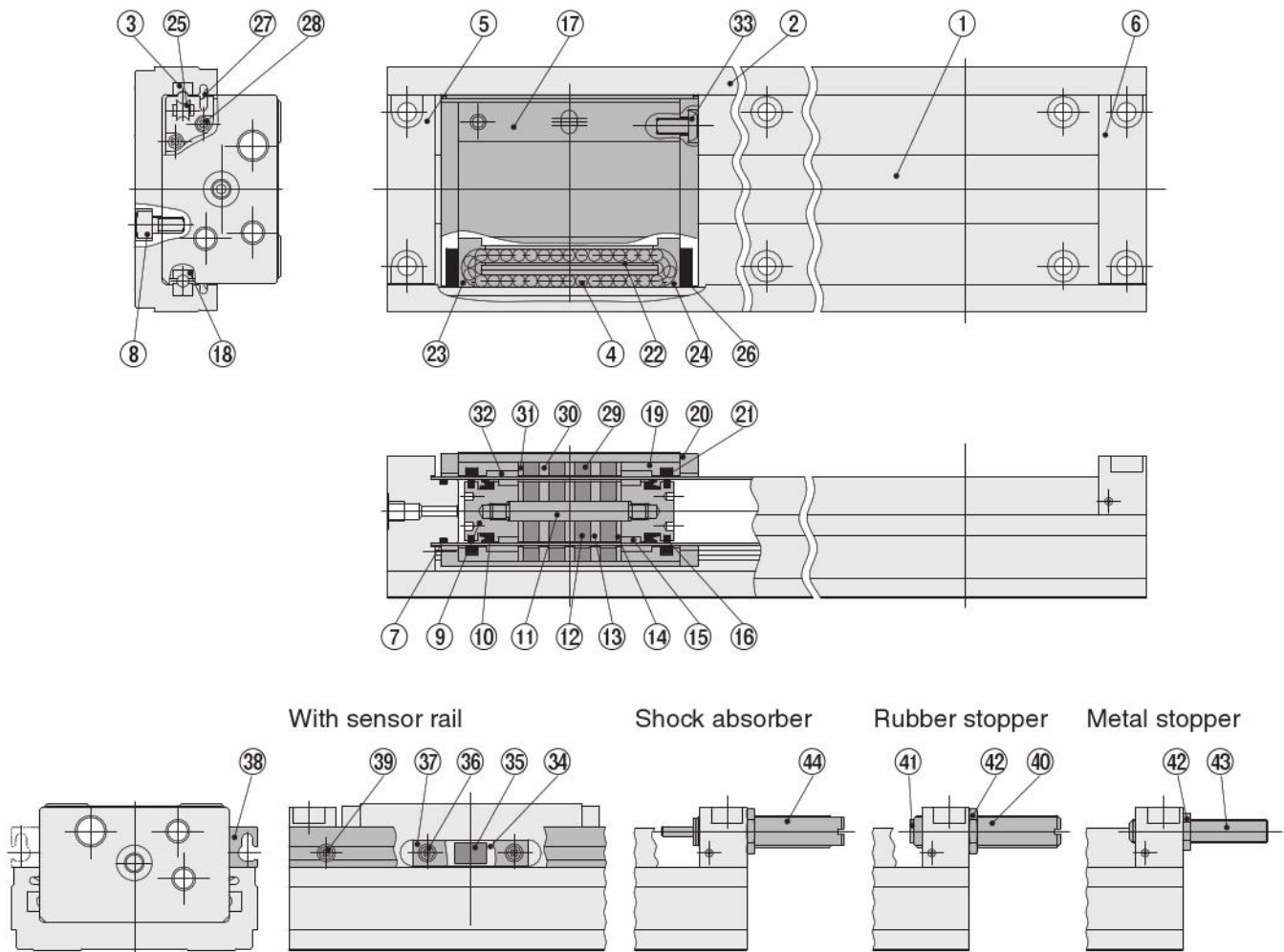

Major parts and materials

No.	Name	Materials	Quantity	Remarks
①	Cylinder tube	Stainless steel	1	
②	Base	Aluminum alloy	1	Anodized
③	Rail	Stainless steel	2	
④	Steel ball	Stainless steel	—	
⑤	End plate R	Aluminum alloy	1	Electroless nickel plated
⑥	End plate L	Aluminum alloy	1	Electroless nickel plated, R and L are common in $\phi 10$
⑦	O-ring	Synthetic rubber (NBR)	2	
⑧	Hexagon socket head screw	Stainless steel	4	
⑨	Piston	Aluminum alloy	2	
⑩	Piston seal	Synthetic rubber (NBR)	2	
⑪	Piston shaft	Stainless steel	1	
⑫	Inner magnet	Rare-earth permanent magnet	4	3 for $\phi 10$
⑬	Inner yoke A	Steel	3	Electroless nickel plated, 2 for $\phi 10$
⑭	Inner yoke B	Steel	2	Electroless nickel plated
⑮	Inner wear ring	Special plastic	2	
⑯	Piston wiper	Polyester fiber	2	
⑰	Slider	Aluminum alloy	1	Electroless nickel plated
⑱	Rail	Stainless steel	2	
⑲	Holder	Aluminum alloy	2	Anodized
⑳	Slider plate	Alloy steel	2	Electroless nickel plated
㉑	Slider wiper	Polyester fiber	2	
㉒	Return pipe	Stainless steel	2	

No.	Name	Materials	Quantity	Remarks
㉓	Return block R	POM	2	
㉔	Return block L	POM	2	
㉕	Return piece	POM	4	
㉖	Guide wiper	Polyester fiber	4	
㉗	Guide seal	Synthetic rubber (urethane)	2	
㉘	Cross-recessed pan head screw	Stainless steel	8	
㉙	Outer magnet	Rare-earth permanent magnet	4	3 for $\phi 10$
㉚	Outer yoke A	Steel	3	Electroless nickel plated, 2 for $\phi 10$
㉛	Outer yoke B	Steel	2	Electroless nickel plated
㉜	Outer wear ring	Special plastic	2	
㉝	Hexagon socket button head screw	Stainless steel	4	
㉞	Shield plate	Steel	—	Electroless nickel plated
㉟	Sensor magnet	Rare-earth permanent magnet	—	
㊱	Magnet holder mounting screws	Stainless steel	—	
㊲	Magnet holder	PBT	—	
㊳	Sensor rail	Aluminum alloy	—	Anodized
㊴	Sensor rail mounting screw	Stainless steel	—	
㊵	Rubber stopper bolt	Alloy steel	—	Electroless nickel plated
㊶	Damper	Synthetic rubber (urethane)	—	
㊷	Hexagon nut	Steel	—	Electroless nickel plated
㊸	Metal stopper bolt	Alloy steel	—	Electroless nickel plated
㊹	Shock absorber	—	—	

Dimensions (mm)

MRB10 × Stroke

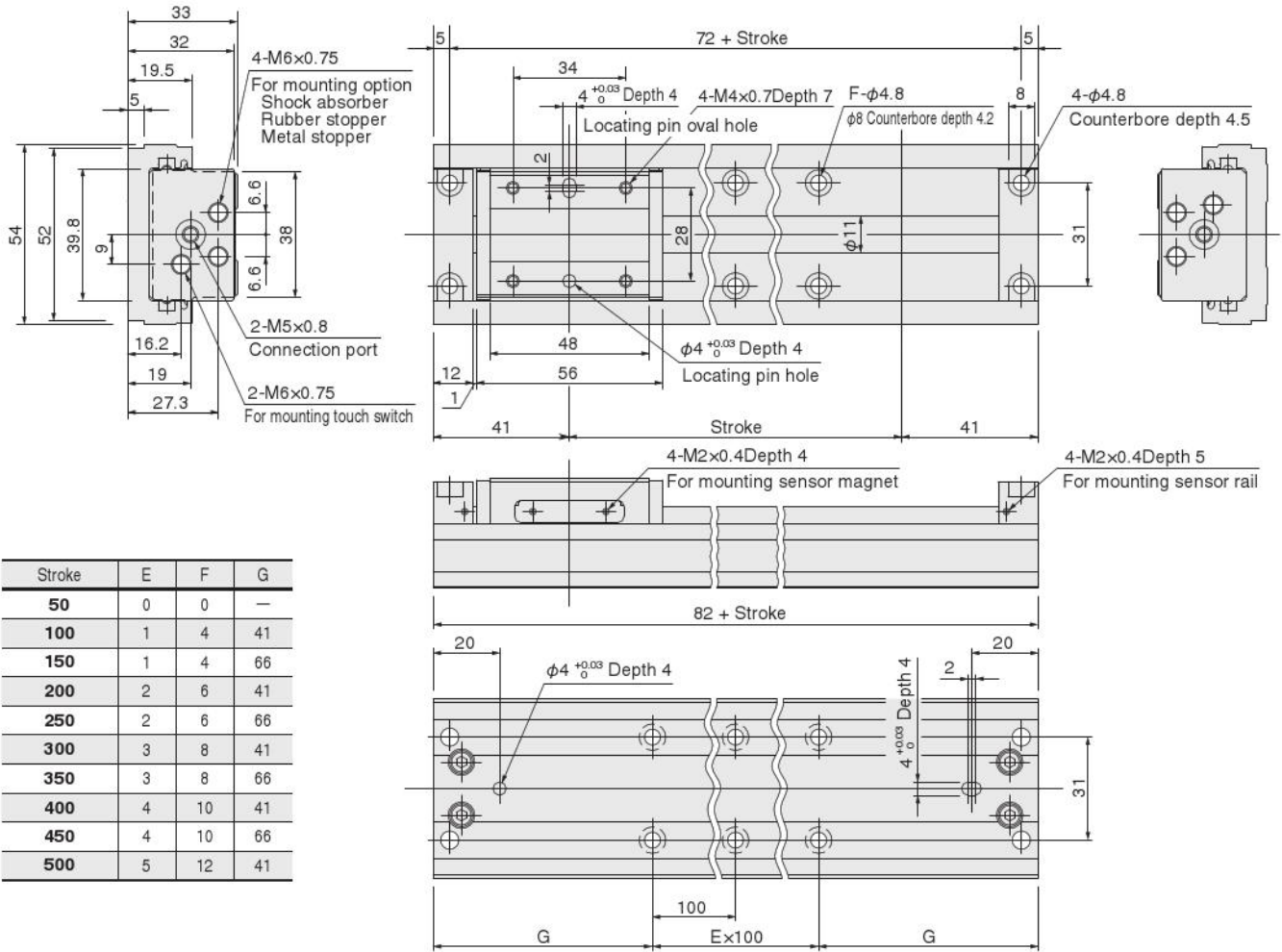

Stroke	E	F	G
50	0	0	—
100	1	4	41
150	1	4	66
200	2	6	41
250	2	6	66
300	3	8	41
350	3	8	66
400	4	10	41
450	4	10	66
500	5	12	41

● Shock absorber

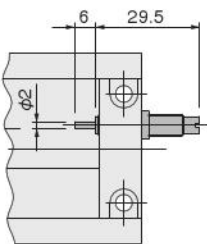

● Rubber stopper

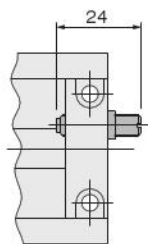

● Metal stopper

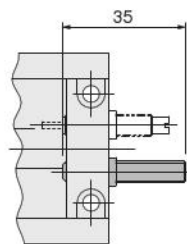

● Touch switch

(Note: When Metrol CS067A is used)

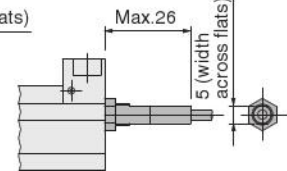
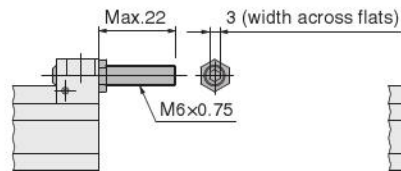
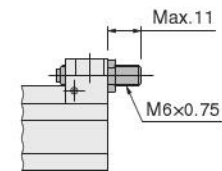
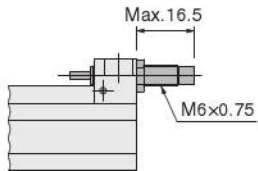
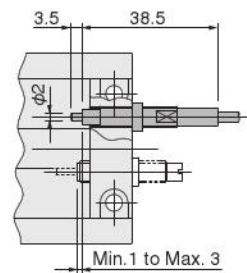

(Touch switch must be provided by you.)

● Sensor rail

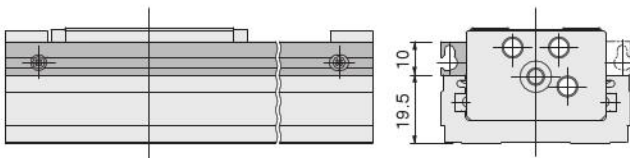

A product equipped with a sensor rail, is shipped with the sensor magnet and sensor rail attached to the slider locating pin hole ($\phi 4$) side. For information about mounting the sensor rail to the opposite side, see the sensor rail and sensor magnet mounting information on page 20.

Dimensions (mm)

MRB16 × Stroke

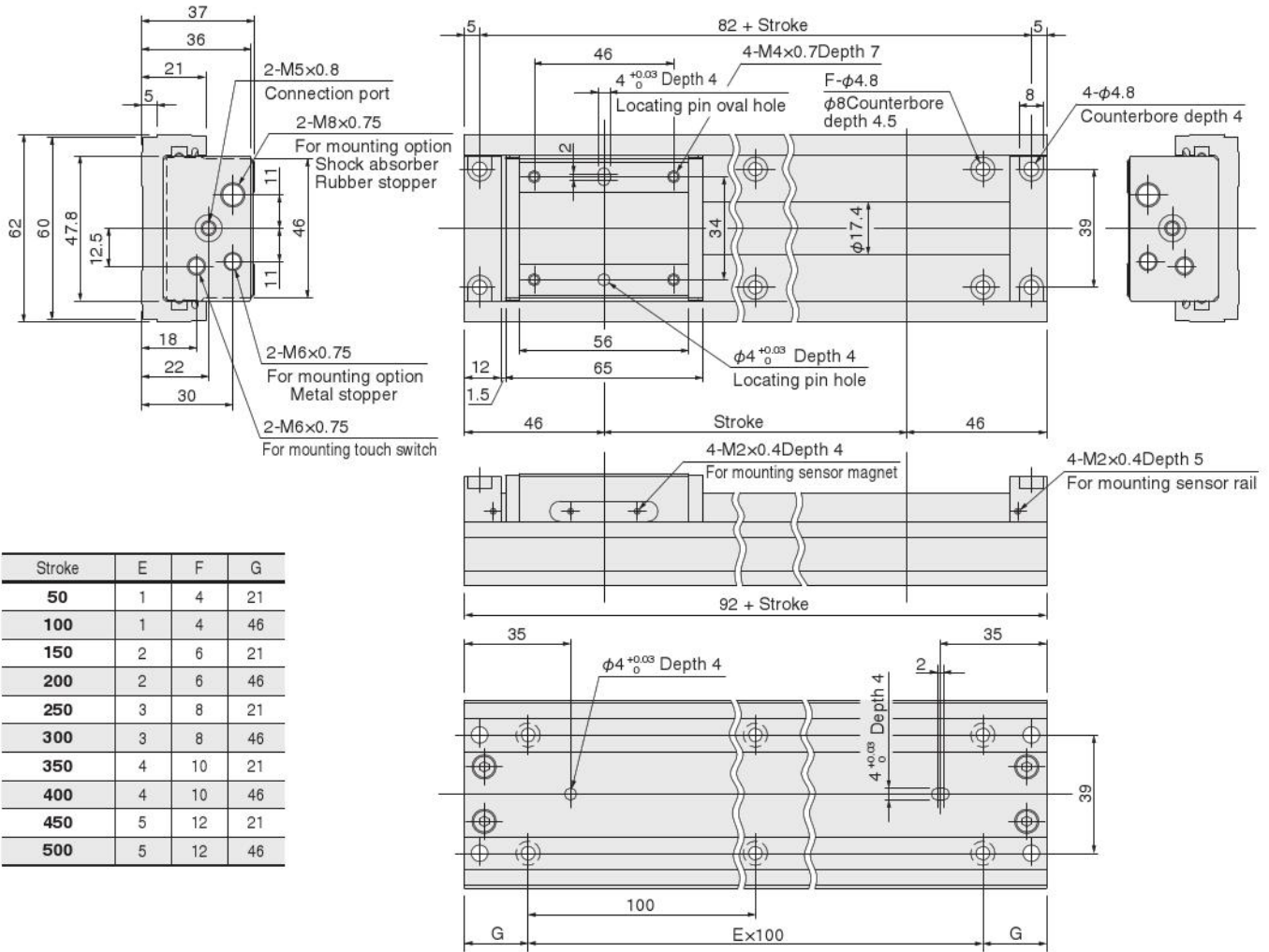

Stroke	E	F	G
50	1	4	21
100	1	4	46
150	2	6	21
200	2	6	46
250	3	8	21
300	3	8	46
350	4	10	21
400	4	10	46
450	5	12	21
500	5	12	46

● Shock absorber

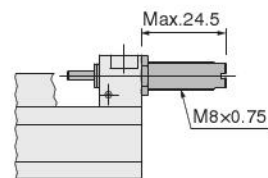
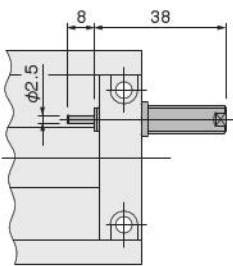

● Rubber stopper

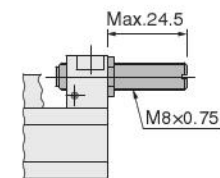
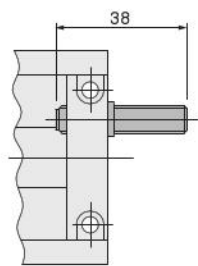

● Metal stopper

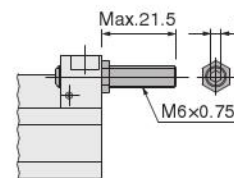
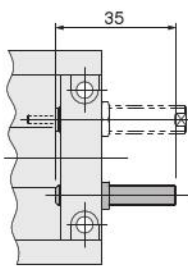

● Touch switch

(Note: When Metrol CS067A is used)

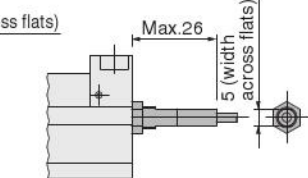
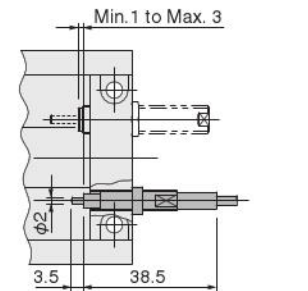

(Touch switch must be provided by you.)

● Sensor rail

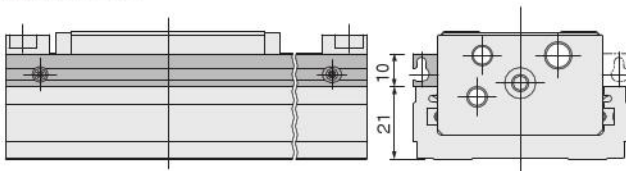

A product equipped with a sensor rail, is shipped with the sensor magnet and sensor rail attached to the slider locating pin hole (φ4) side. For information about mounting the sensor rail to the opposite side, see the sensor rail and sensor magnet mounting information on page 2.

Dimensions (mm)

● Shock absorber

KSHJ6×6-01, -02
H1-KSHJ6×6-01, -02

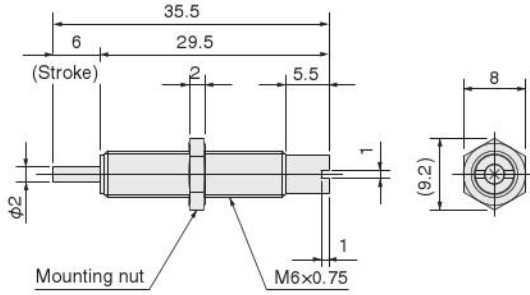

KSHJ8×8-01, -02
H1-KSHJ8×8-01, -02

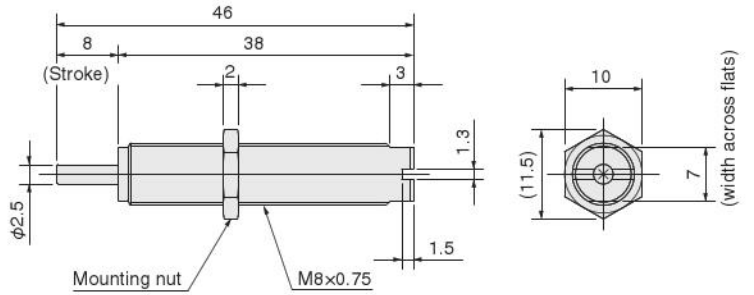

● Rubber stopper

RS-MRB10

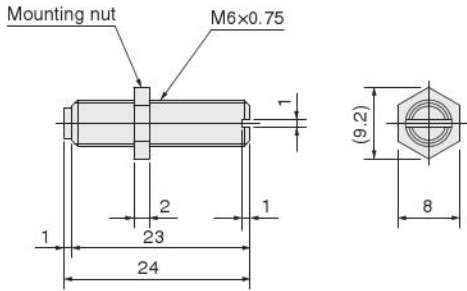

RS-MRB16

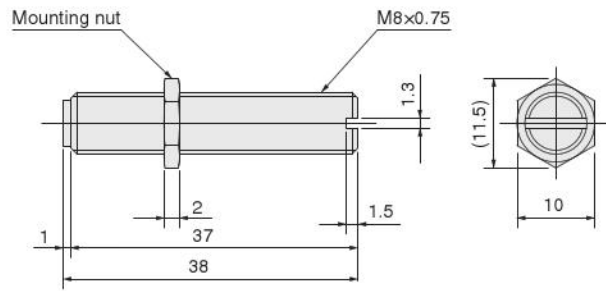

● Metal stopper

MS-MRB10, 16

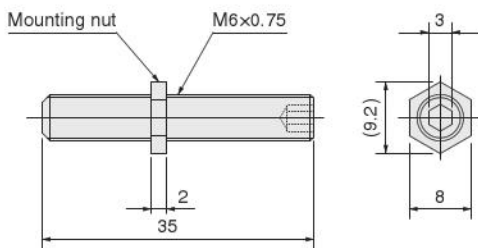

Sensor switch

Solid State Type, Reed Switch Type

Symbol

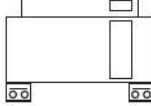

Specifications

● Solid State Type

Item	Model	ZE135□	ZE155□	ZE175□
Wiring method		2-lead wire	3-lead wire with NPN output	3-lead wire with PNP output
Lead wire direction		Horizontal		
Power supply voltage		—	4.5 to 28 VDC	
Load voltage		10 to 28 VDC	4.5 to 28 VDC	
Load current		4 to 20 mA (at 25°C, and 10 mA at 60°C)	50mA MAX.	
Consumption current		—	8 mA MAX. (24 VDC)	10 mA MAX. (24 VDC)
Internal voltage drop ^{Note 1}		4V MAX.	0.5 V MAX. (a voltage of 10 V or less at 20 mA)	
Leakage current		0.7 mA MAX. (24 VDC, 25°C)	50 μA MAX. (24 VDC)	
Response time		1ms MAX.		
Insulation resistance		100 MΩ MIN. (at 500 VDC Megger, between case and lead wire terminal)		
Dielectric strength		500 VAC (50/60 Hz) 1 minute (between case and lead wire terminal)		
Shock resistance ^{Note 2}		294.2 m/s ² (non-repeated)		
Vibration resistance ^{Note 2}		88.3 m/s ² (total amplitude 1.5 mm, 10 to 55 Hz)		
Environmental protection		IP67 (IEC standard), JIS C0920 (watertight type)		
Operation indicators		Red LED indicator lit when ON		
Lead wires ^{Note 3}		PCCV 0.2 SQ x 2-wire (brown and blue) x ℓ	PCCV 0.15 SQ x 3-wire (brown, blue, and black) x ℓ	
Ambient temperature		0 to 60°C		
Storage temperature range		-10 to 70°C		
Mass		15 g (for lead wire length A: 1000 mm), 35 g (for lead wire length B: 3000 mm), 15 g (for lead wire length 300 mm with M8 connector)		

Note 1: Internal voltage drop changes with the load current.

2: According to Koganei test standards.

3: Lead wire length ℓ: A: 1000 mm, B: 3000 mm, G: 300 mm with M8 connector only on the ZE175□

● Reed Switch Type

Item	Model	ZE101□	ZE102□
Wiring method		2-lead wire	
Lead wire direction		Horizontal	
Load voltage		5 to 28 VDC	85 to 115 VAC (r.m.s)
Load current		40 mA MAX.	5 to 40 mA
Internal voltage drop ^{Note 1}		0.1 V MAX. (for load current of 40 mA DC)	3.0 V MAX.
Leakage current		0 mA	
Response time		1ms MAX.	
Insulation resistance		100 MΩ MIN. (at 500 VDC Megger, between case and lead wire terminal)	
Dielectric strength		1500 VAC (50/60 Hz) in 1 minute (between case and lead wire terminal)	
Shock resistance ^{Note 2}		294.2 m/s ² (non-repeated)	
Vibration resistance ^{Note 2}		88.3 m/s ² (total amplitude 1.5 mm, 10 to 55 Hz), resonance frequency 2750 ± 250 Hz	
Environmental protection		IP67 (IEC standard), JIS C0920 (watertight type)	
Operation indicators		None	Red LED indicator lit when ON
Lead wires ^{Note 3}		PCCV 0.2 SQ x 2-wire (brown and blue) x ℓ	
Ambient temperature		0 to 60°C	
Storage temperature range		-10 to 70°C	
Contact protection measure		Required (see page ④ for contact protection.)	
Mass		15 g (for lead wire length A: 1000 mm), 35 g (for lead wire length B: 3000 mm)	

Note 1: Internal voltage drop changes with the load current.

2: According to Koganei test standards.

3: Lead wire length ℓ: A: 1000 mm, B: 3000 mm

Diagram of inner circuits

● Solid State Type

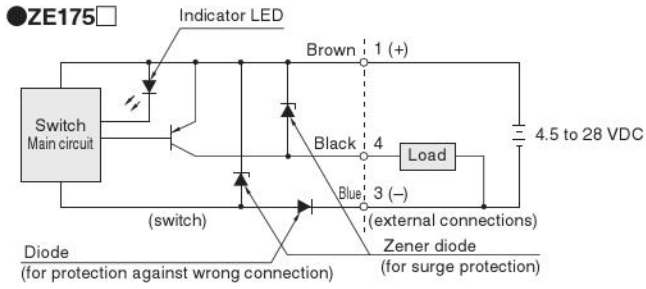
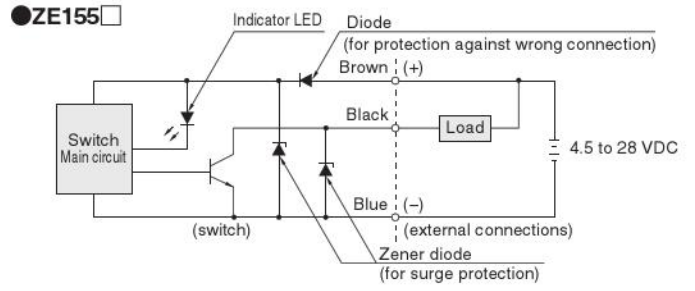
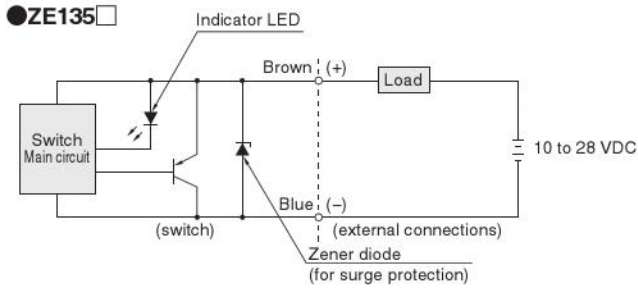

● Reed Switch Type

● ZE101 □

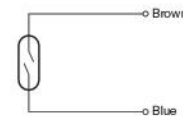

● ZE102 □

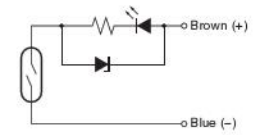

Sensor Switch Dimensions (mm)

● Horizontal lead wire

● Solid state type (ZE135 □, ZE155 □, ZE175 □)

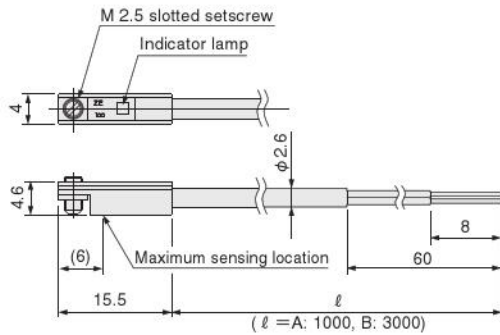

● Reed switch type (ZE101 □, ZE102 □)

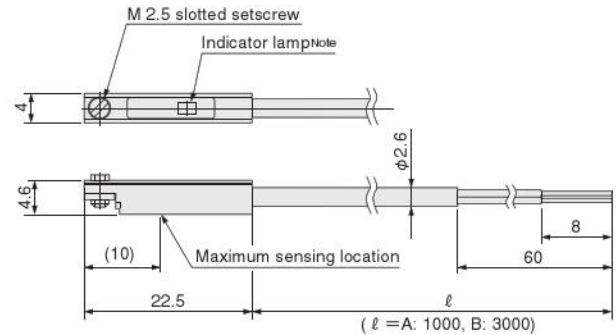

● Solid state type (ZE175G)

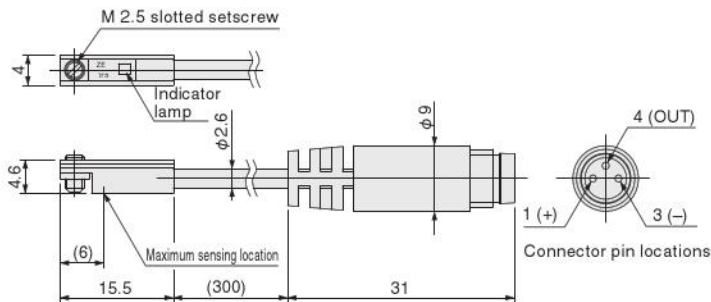

Note: Not available with the ZE101 □.

Sensor Switch Operating Range, Response Differential, and Maximum Sensing Location

● **Operating range: ℓ**

The range from where the piston turns the switch ON and to the point where the switch is turned OFF as the piston travels in the same direction.

● **Response differential: C**

The distance between the point where the piston turns the switch ON and the point where the switch is turned OFF as the piston travels in the opposite direction.

● **Reed Switch Type**

Model	MRB10	MRB16
Operating range: ℓ	7.5 to 9	6.5 to 8
Response differential: C	1 or less	1 or less
Maximum sensing location*	10	

Note: The values in the table above are reference values.
* The value from the opposite end of the lead wire.

● **Solid State Type**

Model	MRB10	MRB16
Operating range: ℓ	3.5 to 5	3 to 4.5
Response differential: C	1 or less	1 or less
Maximum sensing location*	6	

Note: The values in the table above are reference values.
* The value from the opposite end of the lead wire.

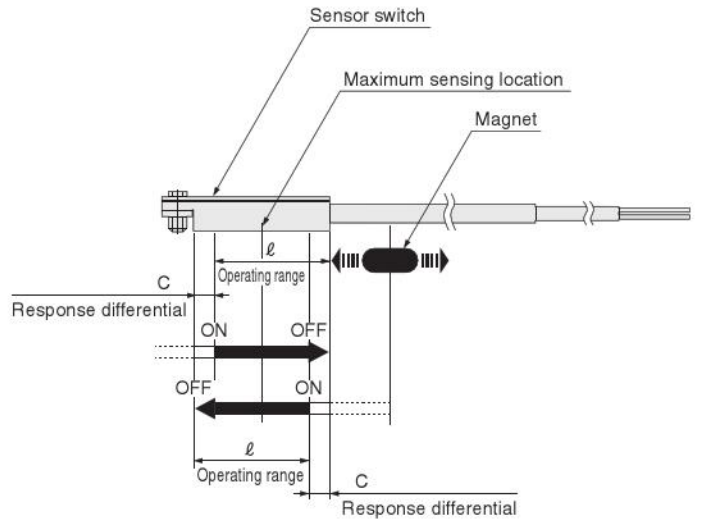

Mounting the Sensor Rail and Sensor Magnet

The MRB Series has tapped holes on both sides for mounting the sensor rail and the sensor magnet. Tighten the screws to the torque values shown in the table below.

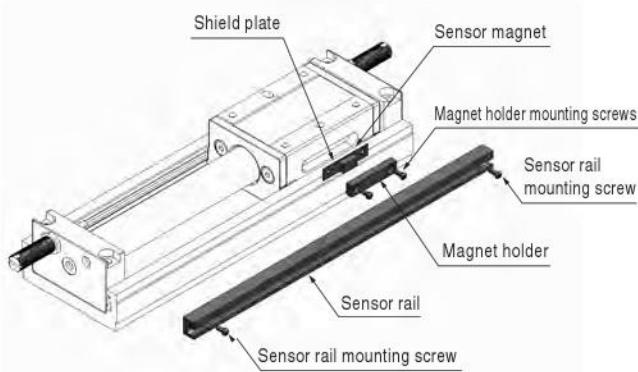

Screw	Tightening Torque	N · m
M2 × 0.4		0.25

Moving Sensor Switch

Loosening the screw allows the sensor switch to be moved along the switch mounting groove of the sensor rail.

● **Screw tightening torque**
0.1N · m to 0.2N · m

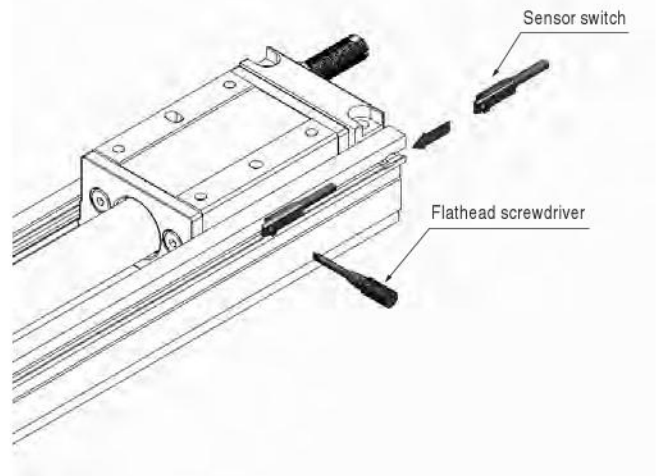

Sensor magnet mounting orientation precautions

Mount the sensor magnet so the black line on the bottom is visible.

However, when mounting on the slider locating pin oval hole side of the MRB10, mount it so the black line on the top is visible.

Mounting it so the black line on the bottom is visible will result in incorrect sensor switch operation.

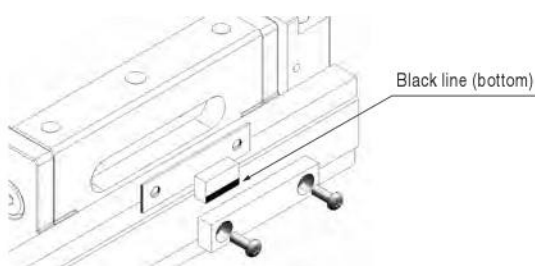

Sensor magnet mounting orientation

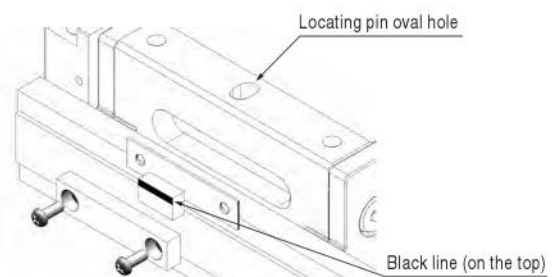

Installation on the MRB10 locating pin oval hole side

Mounting Position of the End of Stroke Detection Sensor Switch

Mounting the sensor switch in the locations shown in the diagram, the magnet comes to the maximum sensing location of the sensor at the end of the stroke and results in stable operation.

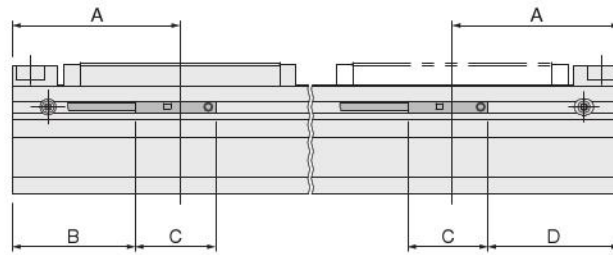

● Reed switch type (ZE101, ZE102)

Model	A	B	C	D
MRB10	41	28.5	22.5	31
MRB16	46	33.5		36

● Solid state type (ZE135, ZE155, ZE175)

Model	A	B	C	D
MRB10	41	31.5	15.5	35
MRB16	46	36.5		40

When Mounting the Cylinders with Sensor Switches in Close Proximity

When mounting MRB Series Cylinders in close proximity, use them at values shown in the table below, or larger than those in the table below.

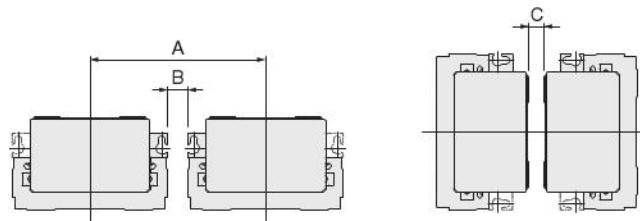

● Reed switch type (ZE101, ZE102)

Model	A	B	C
MRB10	56	2	0
MRB16	62	0	0

● Solid state type (ZE135, ZE155, ZE175)

Model	A	B	C
MRB10	61	7	5
MRB16	65	3	0

Contact Protection for Reed Switch Type Sensor Switch

In order to use the reed switch type sensor switch with stability, take the contact protection measures listed below.

● For connecting an inductive load (electromagnetic relay)

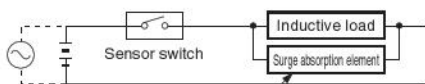

For DC: Diode or CR, etc.

For AC: CR etc.

Diode: Forward current should be more than the circuit current and the reverse voltage should be 10 times greater or more than the circuit voltage.

C: 0.01 to 0.1 μ F
R: 1 to 4 k Ω

● For capacitive surges

(When the lead wire length exceeds 10 m)

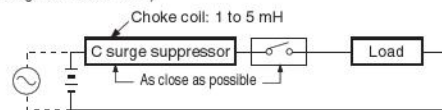

Wiring instructions for the solid state sensor switches

● 2-lead wire type

● Basic connection

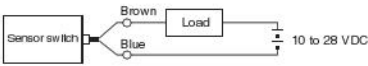

● Connecting with relays

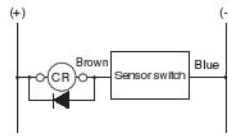

AND (series) connection and OR (parallel) connection

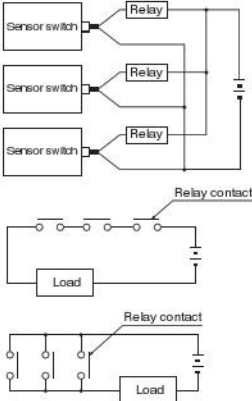

● Connecting with a solenoid valve

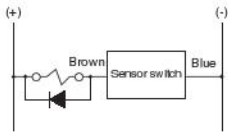

● Connecting with a programmable controller

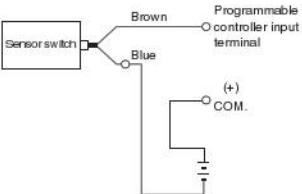

● 3-lead wire type with NPN output

● Basic connection

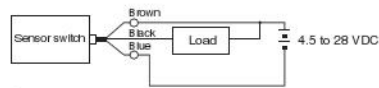

● Connecting with relays

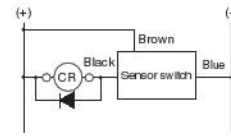

AND (series) connection and OR (parallel) connection

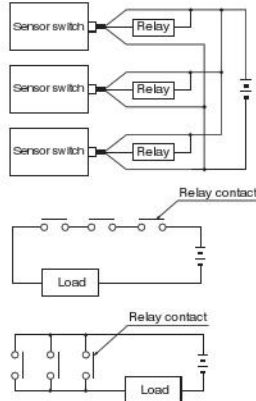

● Connecting with a solenoid valve

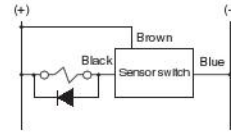

● Connecting with a programmable controller

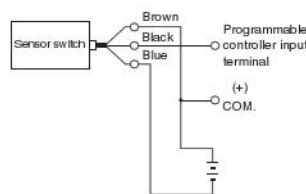

● 3-lead wire type with PNP output

● Basic connection

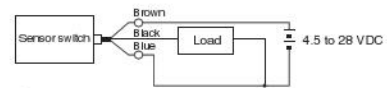

● Connecting with relays

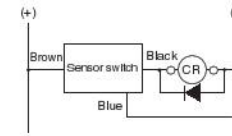

AND (series) connection and OR (parallel) connection

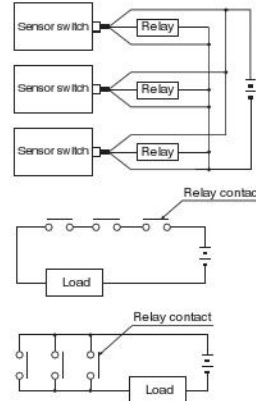

● Connecting with a solenoid valve

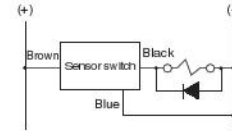

● Connecting with a programmable controller

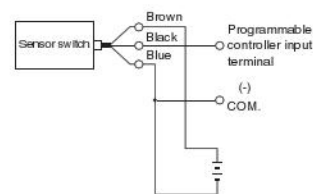

- Note**
1. Connect lead wires according to their color. Incorrect wiring will cause damage to the sensor switch since there is no overcurrent protection.
 2. The use of a surge protection diode is recommended with the inductive load such as an electromagnetic relay.
 3. Avoid the use of AND (series) connections, because the circuit voltage will drop in proportion to the number of sensor switches.
 4. When using an OR (parallel) connection, it is possible to connect sensor switch outputs directly (ex: using corresponding black lead wires). Be aware of load return errors since current leakage increases with the number of switches.

5. Because the sensor switches are magnetically sensitive, avoid using them in locations subject to strong external magnetic fields or bringing them in close proximity to power lines and areas where large electric currents are present. In addition, do not use magnetized materials for the mounting bracket. It could result in erratic operation.
6. Do not pull or bend the lead wires with excessive force.
7. Avoid using the switches in environments where chemicals or gas are present.
8. Consult the nearest Koganei sales office for use in environments subject to water or oil.

Limited Warranty

KOGANEI CORP. warrants its products to be free from defects in material and workmanship subject to the following provisions.

Warranty Period The warranty period is 180 days from the date of delivery.

Koganei Responsibility If a defect in material or workmanship is found during the warranty period, KOGANEI CORP. will replace any part proved defective under normal use free of charge and will provide the service necessary to replace such a part.

Limitations

- This warranty is in lieu of all other warranties, expressed or implied, and is limited to the original cost of the product and shall not include any transportation fee, the cost of installation or any liability for direct, indirect or consequential damage or delay resulting from the defects.

- KOGANEI CORP. shall in no way be liable or responsible for injuries or damage to persons or property arising out of the use or operation of the manufacturer's product.

- This warranty shall be void if the engineered safety devices are removed, made inoperative or not periodically checked for proper functioning.

- Any operation beyond the rated capacity, any improper use or application, or any improper installation of the product, or any substitution upon it with parts not furnished or approved by KOGANEI CORP., shall void this warranty.

- This warranty covers only such items supplied by KOGANEI CORP. The products of other manufacturers are covered only by such warranties made by those original manufacturers, even though such items may have been included as the components.

The specifications are subject to change without notice.

URL <http://www.koganei.co.jp>

E-mail: overseas@koganei.co.jp



KOGANEI CORPORATION

OVERSEAS DEPARTMENT

3-11-28, Midori-cho, Koganei City, Tokyo 184-8533, Japan
Tel: 81-42-383-7271 Fax: 81-42-383-7276

KOGANEI INTERNATIONAL AMERICA, INC.

39300 Civic Center Dr., Suite 280, Fremont, CA 94538, U.S.A.
Tel : 1-510-744-1626 Fax : 1-510-744-1676

SHANGHAI KOGANEI INTERNATIONAL TRADING CORPORATION

Room 2606-2607, Tongda Venture Building No.1, Lane 600, Tianshan Road,
Shanghai, 200051, China
Tel: 86-21-6145-7313 Fax: 86-21-6145-7323

KOGANEI KOREA CO., LTD.

KT&G Cosmo Bldg., 3F, 40-13, Maesanno 2-ga, Paldal-gu, Suwon-si, Gyeonggi-do,
442-847, Korea
Tel: 82-31-246-0414 Fax: 82-31-246-0415

KOGANEI-PORNCHAI CO., LTD.

3300/90, Tower B, Elephant Tower, 16th Fl., Phaholyothin Road, Chomphon,
Chatuchak, Bangkok 10900, Thailand
Tel: 66-2-937-4250 Fax: 66-2-937-4254

KOGANEI ASIA PTE. LTD.

12 Arumugam road #03-12, Lion Building B, 409958, Singapore
Tel: 65-6293-4512 Fax: 65-6293-4513

Dimensions (mm)

MRB20 × Stroke

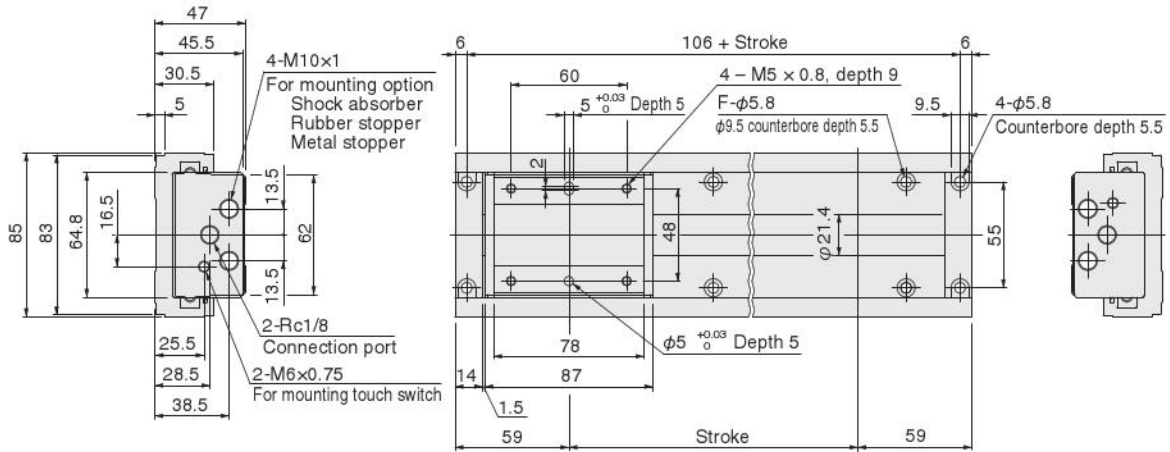

Stroke	E	F	G
50	1	4	34
100	1	4	59
150	2	6	34
200	2	6	59
250	3	8	34
300	3	8	59
350	4	10	34
400	4	10	59
450	5	12	34
500	5	12	59

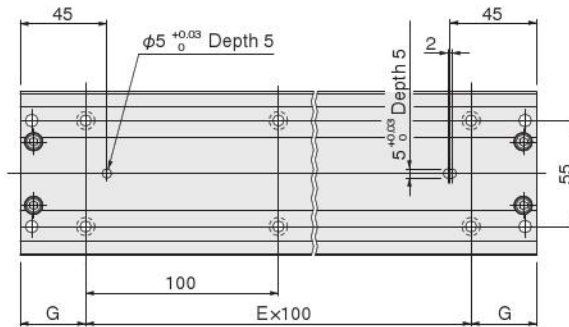
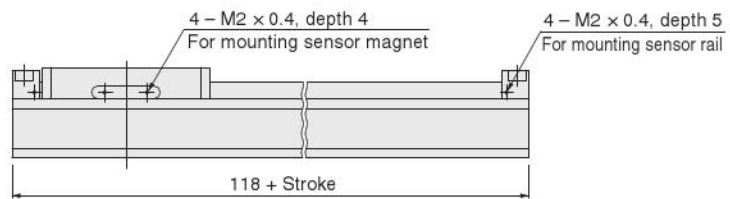

● Shock absorber

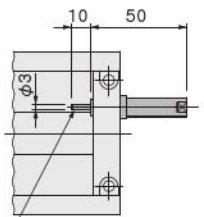

-HL:H1-KSHJ10×10-01
-HM:H1-KSHJ10×10-02

● Rubber stopper

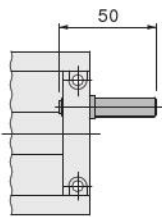

● Metal stopper

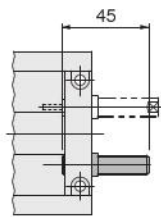

● Touch switch

(Note: When Metrol CS067A is used)

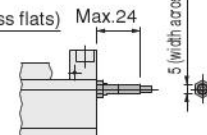
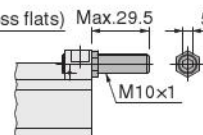
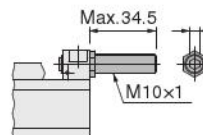
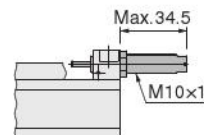
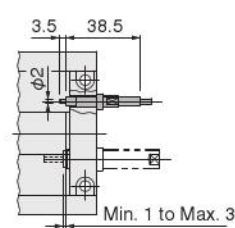

(Touch switch must be provided by you.)

● Sensor rail

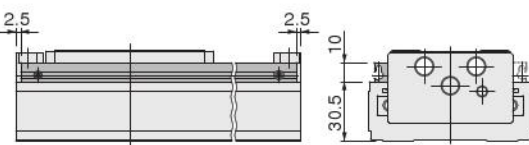

A product equipped with a sensor rail, is shipped with the sensor magnet and sensor rail attached to the slider locating pin hole (φ5) side.

Dimensions (mm)

MRB25 x Stroke

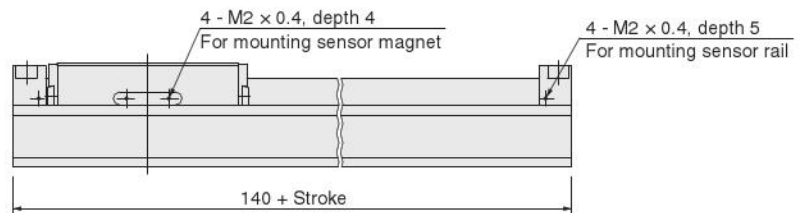
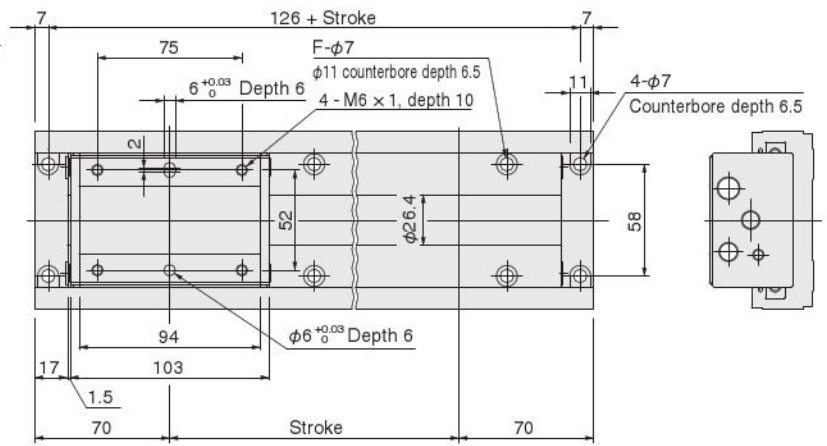
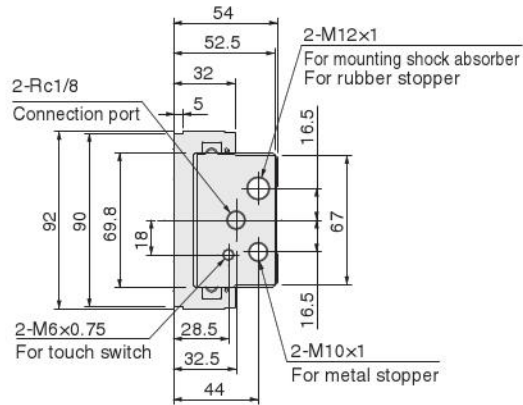

Stroke	E	F	G
50	1	4	45
100	1	4	70
150	2	6	45
200	2	6	70
250	3	8	45
300	3	8	70
350	4	10	45
400	4	10	70
450	5	12	45
500	5	12	70

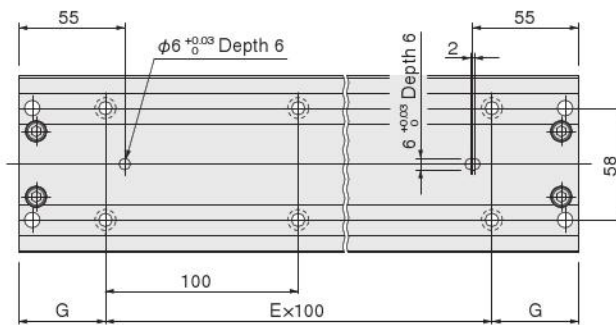

● Shock absorber

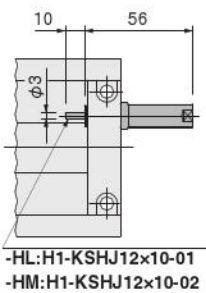

● Rubber stopper

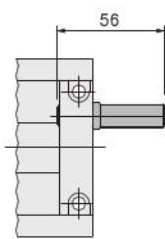

● Metal stopper

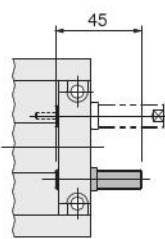

● Touch switch

(Note: When Metrol CS067A is used)

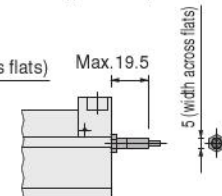
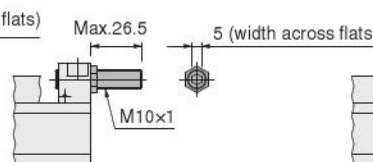
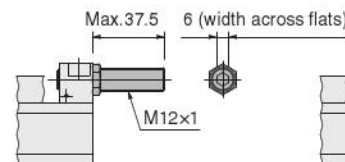
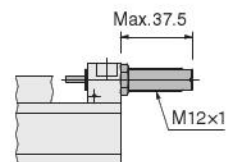
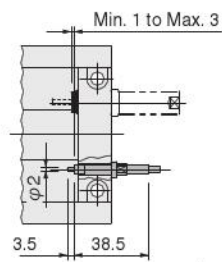

(Touch switch must be provided by you.)

● Sensor rail

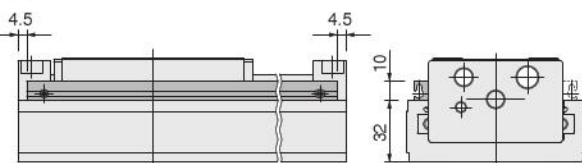

A product equipped with a sensor rail, is shipped with the sensor magnet and sensor rail attached to the slider locating pin hole (φ6) side.



Selection

Allowable load and moment

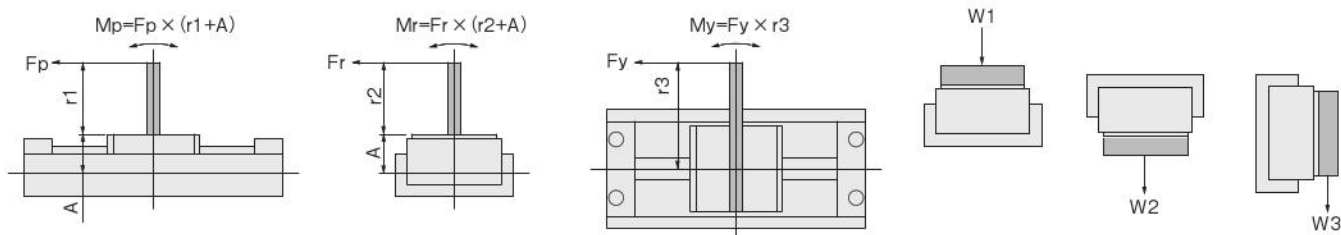

Pitching moment : $M_p = F_p \times (r_1 + A)$ (N · m)
 Rolling moment : $M_r = F_r \times (r_2 + A)$ (N · m)
 Yawing moment : $M_y = F_y \times r_3$ (N · m)
 Maximum load capacity : W1, W2, W3 (N)

Model	A mm
MRB20	28.7
MRB25	34.2

It is possible to apply a load directly to the MRB Series Rodless Cylinder and use it. However, the load and the moment should not exceed the values listed below.

Model	Load	M_p N · m	M_r N · m	M_y N · m	W1 N	W2 N	W3 N
MRB20		14	20	20		140	
MRB25		23	30	30		160	

Slider displacement by moment

(Reference values)

P-part displacement when each moment is applied

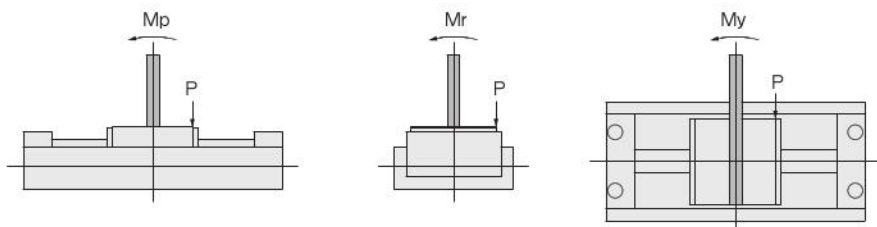

● MRB20

Pitching Moment (M_p)

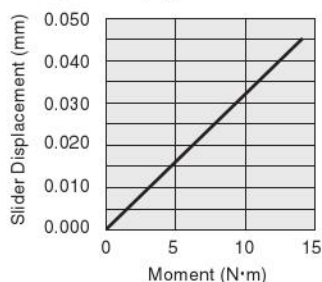

Rolling Moment (M_r)

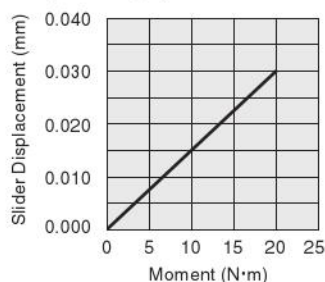

Yawing Moment (M_y)

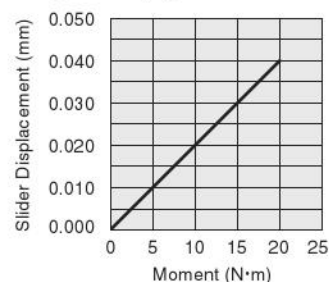

● MRB25

Pitching Moment (M_p)

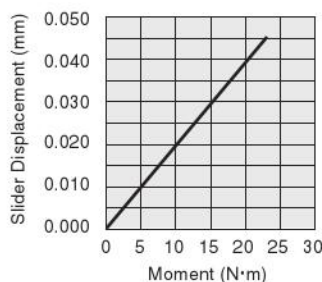

Rolling Moment (M_r)

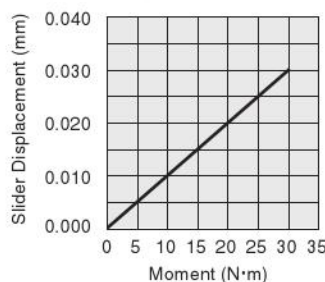

Yawing Moment (M_y)

