



Mini Guide Tables

$\phi 6$ [0.236], $\phi 8$ [0.315], $\phi 10$ [0.394], $\phi 12$ [0.472], $\phi 16$ [0.630], $\phi 20$ [0.787]

Compact High-Precision Actuators

Integration of table guide cylinders



Equipped with linear guides with a 4-point contact system



Thin models

Compact High-Precision Actuators

Mini Guide Tables

High precision mounting

Running parallelism **0.005 mm** [0.0002 in]

Parallelism Mounting **0.03 mm** [0.001 in]

Compact design



4-point contact type linear guide

- 4-point contact system stands up to variable loads and complex loads
- Finite orbit type with cage
- Pre-load applied to reduce vibration

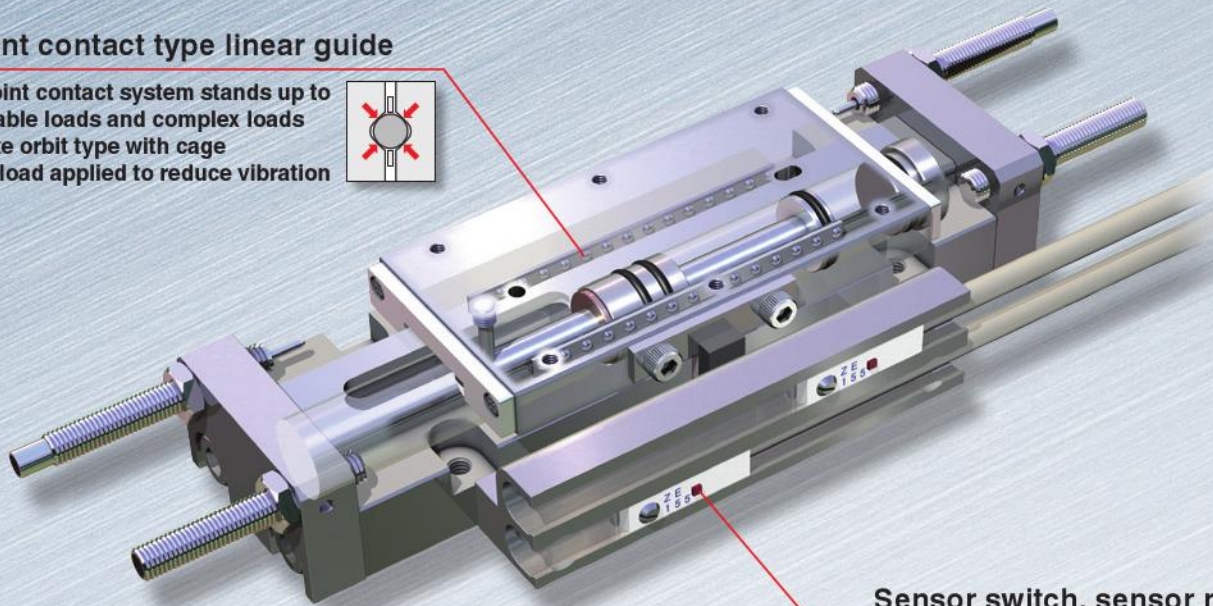
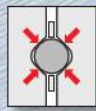

Sensor switch, sensor rail

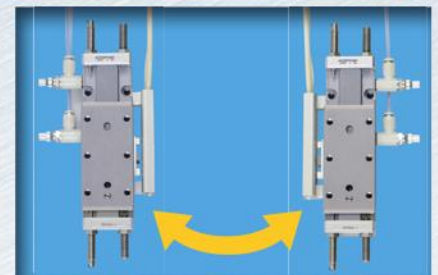

Sensor switches and piping direction can be modified after purchase!

Application Example (Combine with mini guide sliders)

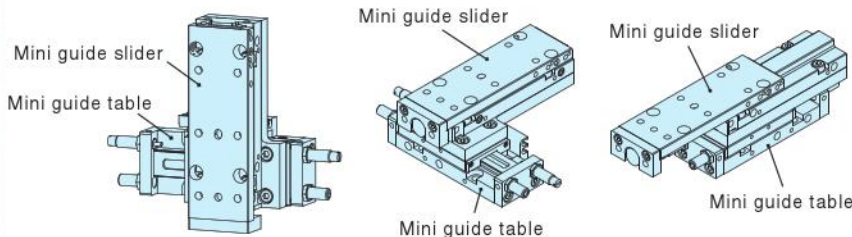

Note: Mini guide tables and mini guide sliders cannot be directly mounted. Note that mounting plates are different.



CAUTION Read the safety precautions on page ③ before using this product.

Product overview

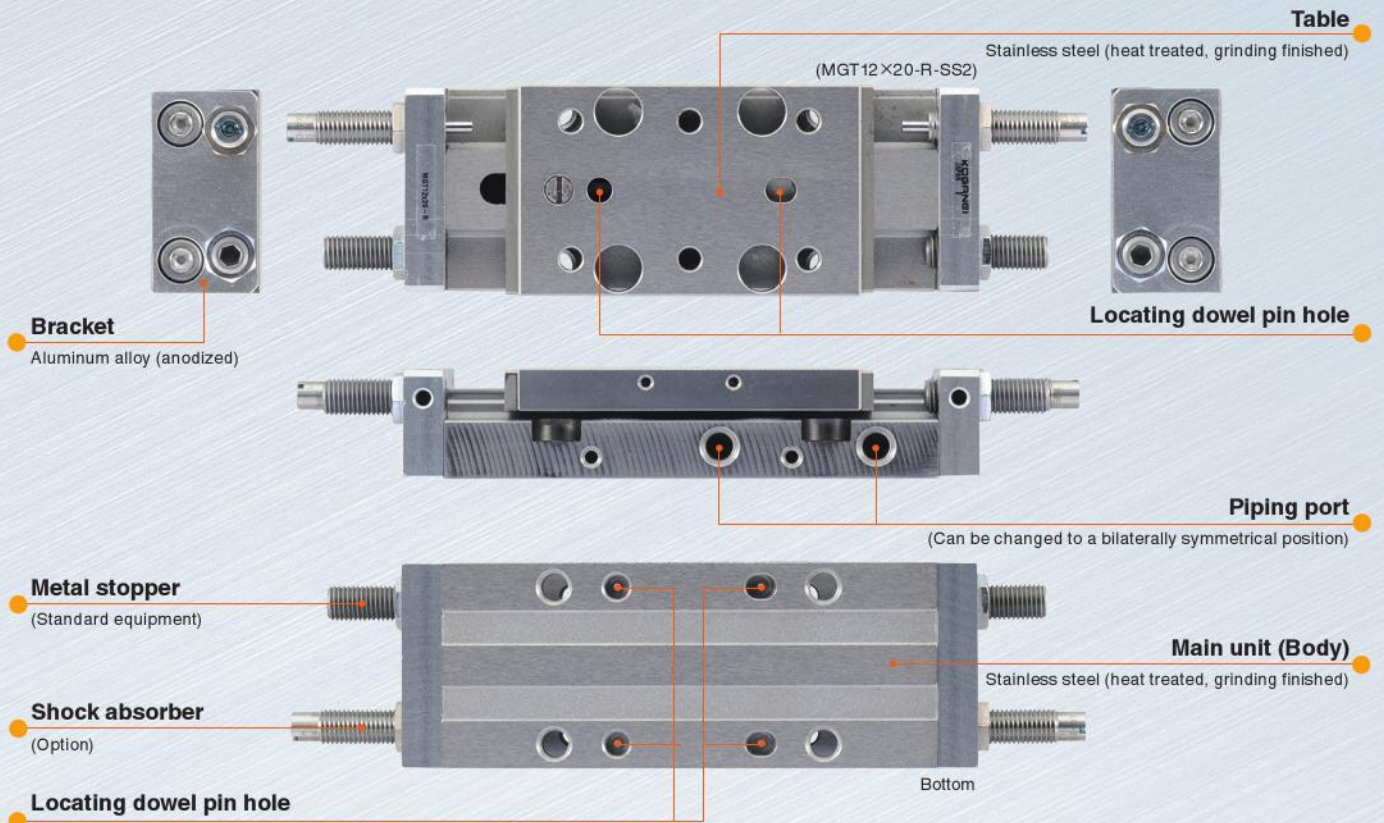

Thin models

The table type allowed us to make it this thin.



(The photo is of the MGT12×20-R-SS2)

Actual size

Supports double stoppers

The metal stopper is used to fix the positioning so there is no mis-positioning when adjusting or changing the shock absorber.

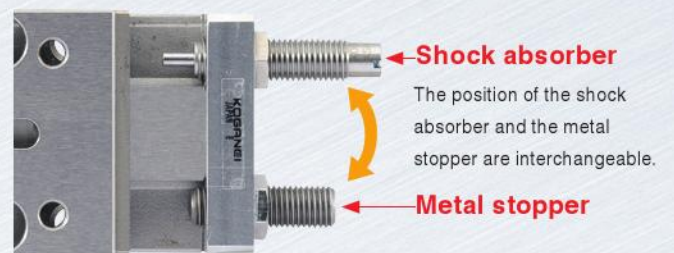

Bore Size and Stroke

mm [in]

Bore size	Standard strokes			
φ 6 [0.236]	10 [0.394]	20 [0.787]	—	—
φ 8 [0.315]	10 [0.394]	20 [0.787]	—	—
φ 10 [0.394]	10 [0.394]	20 [0.787]	30 [1.181]	—
φ 12 [0.472]	—	20 [0.787]	30 [1.181]	50 [1.969]
φ 16 [0.630]	—	20 [0.787]	30 [1.181]	50 [1.969]
φ 20 [0.787]	—	20 [0.787]	30 [1.181]	50 [1.969]





INDEX

Features	1
Safety Precautions	3
Handling instructions and precautions ...	6
Specifications	11
Order codes	13
Inner construction	14
Dimensions	15
Sensor switch	25
Linear magnetic sensor controller ...	32
Guide to related products	33

Before selecting and using the products, please read all the Safety Precautions carefully to ensure proper product use. The Safety Precautions shown below are to help you use the product safely and correctly, and to prevent injury or damage to you, other people, and assets beforehand.

Follow the Safety Precautions for: ISO4414 (Pneumatic fluid power-General rules and safety requirements for systems and their components), JIS B 8370 (Pneumatic fluid Power-General rules relating to systems regulations)

The directions are ranked according to degree of potential danger or damage: "DANGER!", "WARNING!", "CAUTION!", and "ATTENTION!"

 DANGER	Expresses situations that can be clearly predicted as dangerous. If the noted danger is not avoided, it could result in death or serious injury. It could also result in damage or destruction of assets.
 WARNING	Expresses situations that, while not immediately dangerous, could become dangerous. If the noted danger is not avoided, it could result in death or serious injury. It could also result in damage or destruction of assets.
 CAUTION	Expresses situations that, while not immediately dangerous, could become dangerous. If the noted danger is not avoided, it could result in light or semi-serious injury. It could also result in damage or destruction of assets.
 ATTENTION	While there is little chance of injury, this content refers to points that should be observed for appropriate use of the product.

■ This product was designed and manufactured as parts for use in General Industrial Machinery.

- In the selection and handling of the equipment, the system designer or other person with fully adequate knowledge and experience should always read the Safety Precautions, Catalog, Instruction Manual and other literature before commencing operation. Making mistakes in handling is dangerous.
- After reading the Instruction Manual, Catalog, etc., always place them where they can be easily available for reference to users of this product.
- If transferring or lending the product to another person, always attach the Instruction Manual, Catalog, etc., to the product where they are easily visible, to ensure that the new user can use the product safely and properly.
- The danger, warning, and caution items listed under these "Safety Precautions" do not cover all possible cases. Read the Catalog and Instruction Manual carefully, and always keep safety first. Read the catalog and instruction manual carefully, and always keep safety first.

 **DANGER**

- Do not use the product for the purposes listed below:
 1. Medical equipment related to maintenance or management of human lives or bodies.
 2. Mechanical devices or equipment designed for the purpose of moving or transporting people.
 3. Critical safety components in mechanical devices.

This product has not been planned or designed for purposes that require advanced stages of safety. It could cause injury to human life.
- Do not use the product in locations with or near dangerous substances such as flammable or ignitable substances. This product is not explosion-proof. It could ignite or burst into flames.
- When mounting the product and workpieces, always firmly support and secure them in place. Dropping or falling the product or improper operation could result in injury.
- Persons who use a pacemaker, etc., should keep a distance of at least 1 meter [3.28 ft.] away from the product. There is a possibility that the pacemaker will malfunction due to the strong magnet built into the product.
- Never attempt to modify the product. It could result in abnormal operation leading to injury, electric shock, fire, etc.
- Never attempt inappropriate disassembly, assembly or repair of the product relating to basic inner construction, or to its performance or to functions. It could result in injury, electric shock, fire, etc.
- Do not splash water on the product. Spraying it with water, washing it, or using it underwater could result in abnormal operations of the product leading to injury, electric shock, fire, etc.
- While the product is in operation, avoid touching it with your hands or otherwise approaching too close. In addition, do not make any adjustments to the interior or to the attached mechanisms (shock absorbers, stroke adjusting mechanism, sensor switch mounting location, disconnection of piping tubes or plugs, etc.).
The cylinder can move suddenly, possibly resulting in injury.
- When operating the product, always install speed controllers, and gradually loosen the needle valve from a choked state to adjust the speed increasing.
Failure to make this adjustment could result in sudden movements, putting lives at risk.

 **WARNING**

- Do not use the product in excess of its specification range. Such use could result in product breakdowns, function stop, damage, or drastically reduce the operating life.
- Before supplying air or electricity to the device and before starting operation, always conduct a safety check of the area of machine operation. Unintentional supply of air or electricity could possibly result in electric shock, or in injury caused by contact with moving parts.

- Do not touch the terminals and the miscellaneous switches, etc., while the device is powered on. There is a possibility of electric shock and abnormal operation.
- Do not throw the product into fire. The product could explode and/or release toxic gases.
- Do not sit on the product, place your foot on it, or place other objects on it. Accidents such as falling and tripping over could result in injury. Dropping the product may result in injury, or also damage or break the product resulting in abnormal or erratic operation, or runaway, etc.
- When conducting any kind of operation for the product, such as maintenance, inspection, repair, or replacement, always turn off the air supply completely and confirm that residual pressure inside the product or in piping connected to the product is zero before proceeding. In particular, be aware that residual air will still be in the air compressor or air storage tank. The cylinder could abruptly move if residual air pressure remains inside the piping, causing injury.
- Do not use the cylinder for equipment whose purpose is absorbing the shocks and vibrations of mechanical devices. It could break and possibly result in injury or in damage to mechanical devices.
- Avoid scratching the cords for the sensor switch lead wires, etc. Letting the cords be subject to scratching, excessive bending, pulling, rolling up, or being placed under heavy objects or squeezed between two objects, may result in current leaks or defective continuity that lead to fire, electric shock, or abnormal operation.
- Do not subject sensor switches to an external magnetic field during cylinder operation. Unintended movements could result in damage to the equipment or in personal injury.
- Use the product within the recommended load and operating frequency specifications. Attempting to use it beyond the recommended load and operating frequency specifications could damage the table, etc., which could result in damage to the equipment or personal injury. It could also drastically reduce the product's operating life.
- Avoid a control system that will cause the table or a workpiece to drop when the system is abnormal due to an emergency stop, electrical power failure, etc. This could result in damage to the equipment or in personal injury. Always take control measures such as designing a safety circuit or device to prevent the table or workpieces, etc., from dropping in such cases mentioned above.
- Install relief valves, etc., to ensure that the cylinder does not exceed its rated pressure when such pressure is rising due to external forces on the cylinder. Excessive pressure could lead to a breakdown and damage.
- In initial operations after the equipment has been idle for 48 hours or more, or has been in storage, there is a possibility that contacting parts may have stuck together, resulting in equipment operation delays or sudden movements. For these initial operations, always run a test operation before use to check that operating performance is normal.

CAUTION

- Do not use in locations that are subject to direct sunlight (ultraviolet rays), dust, salt, iron powder, high humidity, or in the media and/or the ambient atmospheres that include organic solvents, phosphate ester type hydraulic oil, sulphur dioxide, chlorine gas, acids, etc. It could lead to early shutdown of some functions or a sudden degradation of performance, and result in a reduced operating life. For the materials, see the Major Parts and Materials.
- When installing the product, leave room for adequate working space around it. Failure to ensure adequate working space will make it more difficult to conduct daily inspections or maintenance, which could eventually lead to system shutdown or damage to the product.
- Do not bring magnetic media, etc., within 1 meter [3.28 ft.] of the product. There is the possibility that the data on the magnetic media will be destroyed due to the magnetism of the magnet.
- Do not use the sensor switch in locations subject to large electrical currents or strong magnetic fields. It could result in erratic operation. In addition, do not use magnetized materials in the mounting bracket. The magnetism could leak, possibly resulting in erratic operation.
- Do not place the product too close to magnets. Placing it near magnets or in locations subject to large magnetic field will cause erratic operation of sensor switches due to magnetization of the main body and table, or cause failure by adherence of iron powder, etc.
- Never use other companies' sensor switches with these products. It could possibly cause erratic operation or runaway.
- Do not scratch, dent, or deform the actuator by sitting on the product, using it as a scaffold, or placing objects on top of it. It could lead to damaged or broken products that result in operation shutdown or degraded performance.
- Always post an "operations in progress" sign for installations, adjustments, or other operations, to avoid unintentional supplying of air or electrical power, etc. Such accidental supplies may cause electric shock, or sudden activation of the actuator that could result in physical injury.
- Do not pull on the cords of the lead wires, etc., of the sensor switches mounted on the actuators, grab them when lifting or carrying, or place heavy objects or excessive loads on them. Such action could result in current leaks or defective continuity that lead to fire, electric shock, or abnormal operation.
- When dry air with a dew-point temperature lower than minus 20 degrees [-4 °F] is used, the quality of the lubricant used may deteriorate. This can cause reduced performance or shutdown of functions.

ATTENTION

- When considering the possibility of using this product in situations or environments not specifically noted in the Catalog or Instruction Manual, or in applications where safety is an important requirement such as in an aircraft facility, combustion equipment, leisure equipment, safety equipment and other places where human life or assets may be greatly affected, take adequate safety precautions such as the application with enough margins for ratings and performance or fail-safe measure. Be sure to consult us with such applications.
- Always check the Catalog and other reference materials for product wiring and piping.
- Use a protective cover, etc., to ensure that human bodies do not come into direct contact with the operating portion of mechanical devices, etc.
- Do not control in a way that would cause a workpiece to fall during power failure. Take control measures so that they prevent the table or workpieces, etc., from falling during a power failure or emergency stop of the mechanical devices.
- When handling the product, wear protective gloves, safety glasses, safety boots, etc., to keep safety.
- When the product can no longer be used, or is no longer necessary, dispose of it appropriately as industrial waste.
- Pneumatic equipment can exhibit degraded performance and function over its operating life. Always conduct daily inspections of the pneumatic equipment, and confirm that all requisite system functions are satisfied, to prevent accidents from happening.
- For inquiries about the product, consult your nearest Koganei sales office or Koganei overseas department. The address and telephone number is shown on the back cover of this catalog.

OTHERS

- Always observe the following items.
 1. When using this product in pneumatic systems, always use genuine Koganei parts or compatible parts (recommended parts). When conducting maintenance and repairs, always use genuine Koganei parts or compatible parts (recommended parts). Always observe the required methods and procedure.
 2. Do not attempt inappropriate disassembly or assembly of the product relating to basic configurations, or its performance or functions.

Koganei cannot be responsible if these items are not properly observed.

Safety Precautions (Sensor Switches)

Always read these precautions carefully before use.



Design and selection

Warning

- 1. Check the specifications.**

As use of this product over the specified ranges of voltage, current, temperature, shocks, etc., could result in a breakdown or abnormal operation, always read the specifications carefully to ensure correct use.
- 2. Avoid mounting cylinders in close proximity.**

Mounting two or more cylinders with sensor switches in close proximity could result in erratic operation of the sensor switches, due to magnetic field interference with the system.
- 3. Caution about sensor switch ON time for positioning detection at intermediate stroke position.**

Take caution that if the sensor switch is mounted at an intermediate position of the cylinder stroke for detection of the piston travel, the sensor switch actuation time may be too short when the cylinder speed is very rapid, so that the load (programmable controller, etc.) may fail to activate. Maximum cylinder speed for positioning detection

$$V \text{ (mm/s) [in./sec.]} = \frac{\text{Sensor switch operating range (mm) [in.]}}{\text{Time required for activating load (ms)}} \times 1000$$

- 4. Keep wiring as short as possible.**

The solid state sensor switch lead wire length should be within 30 m [98 ft.] as stipulated in the EN standards. For the reed sensor switch, if the lead wire is too long (10 m [33 ft.] or longer), capacitive surges will shorten the operating life of the sensor switch. If long wiring is needed, install the protection circuit mentioned in the Catalog. If the load is inductive or capacitive, also install the protection circuit mentioned in the Catalog.
- 5. Avoid repeated or excessive bending or pulling of lead wires.**

Applying repeated bending stress or tension force on the lead wire could result in wire breakage.
- 6. Check for leakage current.**

2-lead wire solid state sensor switches produce leakage current to activate their internal circuits, and the current passes through a load even when in the turned-off condition. Ensure they satisfy the following inequality.

$$\text{Input off current of programmable controller} > \text{Leakage current}$$

If the above inequality cannot be satisfied, select a 3-lead wire solid state sensor switch, instead. Also note that parallel connection of a total of n sensor switches will multiply the amount of leakage current by n times.

Caution

- 1. Check for sensor switch internal voltage drop.**

Series connection of reed sensor switches with indicator lamps or 2-lead wire solid state sensor switches causes increasing internal voltage drop, and the load may fail to activate. A total of n sensor switches will lead to n times the internal voltage drop. Ensure that the system satisfies the following inequality.

$$\text{Supply voltage} - \text{Internal voltage drop} \times n > \text{Minimum operating voltage for load}$$

In relays with rated voltage of less than DC24V, check to see whether the above inequality is satisfied, even in the case of $n = 1$. If the above inequality cannot be satisfied, select a reed sensor switch without indicator lamp.

- 2. Do not use our sensor switches with other companies' cylinders.**

The sensor switches are designed for use with Koganei cylinders only and may not function properly when used with other companies' cylinders.



Installation and adjustment

Warning

- 1. Do not apply an external magnetic field to the sensor switch while the cylinder is in operation.**
An unintended movement could result in damage to the equipment or in personal injury.

Caution

- 1. Ensure a safe installation environment for the cylinders with sensor switches.**
Do not use sensor switches in places where large current or magnetic fields are present. This could lead to unintentional operation. Do not use magnetic material for the mounting brackets. It could result in erratic operation.
- 2. Install sensor switches in the center of their operating range.**
Adjust the mounting position of a sensor switch so that the piston stops in the center of its operating range (the range while the sensor turns ON). Operations will be unstable if mounted at the end of the operating range (at the boundary near ON or OFF). Also be aware that the operating range will vary with changes in temperature.
- 3. Follow the tightening torque of sensor switches when mounting.**
Over-tightening beyond the allowed tightening torque may damage the mounting threads, mounting brackets, sensor switches, etc. In addition, insufficient tightening torque could cause the sensor switch position to be changed, resulting in operation instability. For the tightening torque, follow the instructions on page 30.
- 4. Do not carry the cylinder grabbing its sensor switch lead wires.**
After mounting a sensor switch to a cylinder, do not grab and lift the lead wires to carry the cylinder. Never do this, as it could result in lead wire disconnections, and could also apply stress to the interior of the sensor switch, resulting in breakage of internal elements.
- 5. Do not drop sensor switches, or bump them against others.**
During handling of sensor switches, do not apply excessive shocks (294.2 m/s² [30 G] or larger) such as hitting, dropping, or bumping.
In reed sensor switches, the contact reed may be activated unintentionally, causing it to send or break sudden signals. It may also cause changes in the contact distance that lead to changes in sensor switch sensitivity and result in erratic operation. Even if the sensor switch case is undamaged, the inner parts of the sensor switch may suffer breakdown and cause erratic operation.



Wiring

Danger

- 1. Avoid letting moving objects near sensor switches come into contact with them.**
When the cylinders with sensor switches are moving, or when moving objects are nearby, do not let them come into contact each other. In particular, lead wires could become worn out or damaged, causing operating instability in the sensor switch. In the worst case, it could result in current leaks or electric shock.
- 2. Always turn off the power supply for wiring work.**
Conducting wiring work while the power is on could result in electric shock. Also, incorrect wiring could damage sensor switches in an instant. Turn on the power only after the wiring work is completed.

Warning

- 1. Check the Catalog, etc., to ensure that the sensor switch wiring is correctly connected.**
Miswiring could result in abnormal operation.
- 2. Do not share the same wiring with power or high voltage lines.**
Avoid wiring in parallel to or shared in the same conduit with power or high voltage lines.
The sensor switch or control circuit may suffer electric noise that results in erratic operation.
- 3. Avoid repeated or excessive bending or pulling of lead wires.**
Applying repeated bending stress or tension force on the lead wire could result in wire breakage.
- 4. Check polarity in the wiring.**
In polarity (+, -, output) specified sensor switches, make sure that wiring connections are correct. The wrong polarity could result in damage to sensor switches.

Caution

- 1. Avoid short circuiting the loads.**
Turning a sensor switch on while the load is short-circuited causes overcurrent, which will damage the sensor switch in an instant.
Example of short-circuited load: Sensor switch's output lead wire is directly connected to the power supply.
- 2. Position sensor switches in the center of their operating range.**
Sensor switch operations may be unstable, depending on the operating environment, if positioned at the edge of the operating range.
- 3. Solid state sensor switches that are compliant with the EMC standards (EN61000-6-2 and EN60947-5-2) are not resistant to surges from lightning. Use countermeasures on the machine to protect them from lightning surges.**
- 4. Use an internal element to absorb surges for direct activation of loads that generate surges.**

Warranty and General Disclaimer

- 1. Warranty Period**
Koganei warrants this product for a period of no more than 180 days after it is shipped.
- 2. Scope of Warranty, and General Disclaimer**
 - (1) The Koganei product warranty covers individual products. When a product purchased from Koganei or from an authorized Koganei dealer or Koganei distributor malfunctions during the warranty period in a way that is found to be attributable to Koganei responsibility, Koganei will repair or replace the product free of charge. Even if a product is still within the warranty period, its durability is determined by its operation cycles and other factors. Contact your nearest Koganei sales office or the Koganei overseas department for details.
 - (2) Koganei shall not be held responsible for any loss induced by failure of a Koganei product or its diminished function or performance, or for any loss involving other equipment induced in this manner.
 - (3) Koganei shall not be held responsible for any losses due to use or storage of the product in a way that is outside of the product specifications prescribed in Koganei catalogs and the instruction manual, and/or due to actions that violate the mounting, installation, adjustment, maintenance and other safety precautions.
 - (4) Koganei shall not be held responsible for any losses caused by breakdown of the product due to factors outside the responsibility of Koganei, including but limited to fire, natural disaster, the actions of third parties, and international actions or errors by you.

(Linear Magnetic Sensor Controller)

Danger

- Do not use the linear magnetic sensor controller or sensor head in locations where dangerous substances such as flammable or ignitable substances are present or nearby. These sensor controllers and sensor heads are not explosion-proof. They could ignite or burst into flames.
- Do not make any adjustments to the attached mechanisms (connection/disconnection of wiring connectors, mounting or positioning of the sensor head, etc.) while the product is in operation. This could result in abnormal operation leading to injury.

Warning

- Avoid damaging the cords of the sensor head lead wires, etc. Allowing the cords to be damaged, bent excessively, pulled, rolled up, placed under heavy objects or squeezed between two objects, may result in current leaks or defective continuity that will lead to fire, electric shock, or abnormal operation.
- Do not apply an external magnetic field to the controller and sensor head while the linear magnetic sensor controller is in operation. Unintended movements could result in damage to the equipment or in personal injury.
- Avoid wiring parallel to or in the same conduit as power or high-voltage lines. The linear magnetic sensor controller may be affected by electric noise that results in erratic operation.
- Make sure that the polarity of wiring connections is correct. The wrong polarity could result in damage to the linear magnetic sensor controller and sensor head.
- When installing two or more cylinders equipped with the sensor heads of linear magnetic sensor controllers in parallel, secure a clearance of at least 40 mm [1.575 in] between cylinder body surfaces. Otherwise erratic operation could result.

Caution

- Do not use the linear magnetic sensor controller or sensor head in locations subject to large electrical currents or strong magnetic fields. This could result in erratic operation.
- Do not pull on the cords of the lead wires, etc., of the linear magnetic sensor controller and sensor head, grab them when lifting or carrying the equipment, or place heavy objects or excessive loads on them. Such actions could result in current leaks or defective continuity that leads to fire, electric shock, or abnormal operation.
- Be sure to use the specified sensor heads for each product. Use of sensor heads other than those specified could lead to erratic operation of, or damage to, the product.
- When handling linear magnetic sensor controllers and sensor heads, do not apply excessive shocks (294.2 m/s² [30 G] or larger) by striking, dropping, or bumping against them. Even if their casing is undamaged, their inner parts may suffer breakdown, causing erratic operation.
- Avoid short circuiting the loads.
Turning the switch output on while the load is short-circuited causes overcurrent, which will damage the linear magnetic sensor controller.
Example of short-circuited load: The lead wire of a switch output is directly connected to the power supply.
- Tighten screws with a tightening torque of 0.2 N·m [1.8 in·lbf] when mounting the sensor head.
Over-tightening beyond the allowed tightening torque may damage the sensor head.
Be sure to connect the sensor head and controller while the power is turned off. Connecting the sensor head while the power is supplied may cause erratic operation of the controller because of surge voltage, etc.

Handling Instructions and Precautions (Mini Guide Tables)



General precautions

Allowable kinetic energy

To carry an inertial load, operate the Mini Guide Tables with the kinetic energy below the allowable value. For details about the relation between the load and table speed, see "Allowable load mass" on page 9.

Piping

In piping connection with the Mini Guide Tables, flush the tube completely (by blowing compressed air) before piping. Intrusion of machining chips, sealing tape, rust, etc., generated during plumbing could result in air leaks and other defective operations.

Media

1. Use air for the media. For the use of any other media, consult us.
2. Air used for the Mini Guide Tables should be clean air that contains no deteriorated compressor oil, etc. Install an air filter (filtration of a minimum 40 μm) near the Mini Guide Tables or valve to remove collected liquid or dust. In addition, drain the air filter periodically. Collected liquid or dust entering the Mini Guide Tables may cause improper operation.

Lubrication

1. The standard cylinder can be used without lubrication, if lubrication is required, use Turbine Oil Class 1 (ISO VG32) or equivalent. Avoid using spindle oil or machine oil.
2. Apply CGL grease (Nippon Thompson Co., Ltd. made) on the raceway surface of the track rail in the guide portion every six months or 3 million operations.

Atmosphere

1. When using in locations subject to dripping water, dripping oil, etc., or to large amounts of dust, use something to cover and protect the unit.
2. Do not use the Mini Guide Tables in a corrosive atmosphere. Use in such surroundings causes damage or malfunctions.
3. The main body and table are made of stainless steel. However, they may rust depending on the operating environment. Apply rust preventing oil to them periodically. Note that touching the body of the product with a bare hand may cause rusting because of salt content in sweat. It is advisable to wear gloves.
4. Do not use the products under extremely dry conditions.
5. The ambient temperature range most suitable for use of the Mini Guide Tables is from 5 to 60°C [41 to 140 °F]. Use at temperatures exceeding 60°C [140 °F] causes damage or malfunctions. When the temperature is 5°C [41°F] or below, moisture in the air is frozen to cause damage and malfunctions. Take some anti-freezing measures.

Handling Instructions and Precautions

During Operation

1. Do not place hands in the operating direction of the Mini Guide Tables.
2. At initial operation, pay sufficient attention to the operating direction of the table.
3. Be careful that no part of your body is pinched between the table and bracket.
4. For maintenance, check that there is no residual pressure in the cylinder.
5. Use the metal stopper at its standard usage speed of 300 mm/s [11.8 in/sec] or below (the usage speed when a shock absorber is attached is 500 mm/s [19.7 in/sec] or lower). Even within the allowable range, if the speed and load are large, install external stoppers to avoid applying direct shocks to the table.
6. When using a table with an external stopper so reciprocal operation is normally performed for only part of the stroke with occasional full-stroke operation, full-stroke operation may not be possible even if the external stopper is removed. This is because repeated use within a limited range causes the steel balls and cage to go out of normal position. To avoid this, full-stroke operation is recommended on a periodic or operation count basis.
7. The Mini Guide Tables is made of martensitic stainless steel, so it will become magnetized if it comes into contact with a magnet or magnetic object. Note that magnetization may cause incorrect sensor switch operation.
8. The rod cover may move due to the occurrence of negative pressure inside the cylinder when the table is moved by the external force caused by the closure of the pipe port on the rod side (the center part of the body) when the piston rod is protruding (a state in which you cannot see the oval hole of the body). Also, it may cause air blowout, damage to packing, and air leaks.
9. Do not put foreign objects inside the body through the body's oval hole.
Doing so may cause damages or defective operation.
10. Do not loosen connecting pins. Doing so can lead to malfunction.



Installation and adjustment

Mounting

1. While any mounting direction is allowed, the flatness of the mounting surface of the workpiece or base should be 0.02 mm [0.0008 in.] or less. Improper flatness causes looseness in the guide portion, increases the rolling resistance, and adversely affects the product operating life.
2. Care should be taken that scratches or dents on the table's mounting surface may damage its flatness.
3. In applications subject to large shocks, reinforce the mounting by using screws to install an additional support to the cylinder body, etc.
4. The table is supported by steel balls, so be careful to avoid strong impact and excess moment when mounting workpieces. Hold the table when fastening the workpiece to the table with bolts. If you hold the body when tightening the bolts, it reduces the precision by placing too large a moment on the guide.
5. Ensure adequate strength of the mounting screws for the cylinder. When mounting the cylinder, tighten the screws with torque within the allowable range.
6. Take measures against looseness of the screws when shocks or vibrations might loosen the screws.
7. Use clearance fit locating pins (optional stepped pins) for locating dowel pin holes. When a press-fit pin is used, excessive loads generated while pressing will cause a failure in the guide. Furthermore, the pin holes of the table are through holes, using pins other than the stepped pins will bump against the main body, causing a failure.

NOTE When mounting the Mini Guide Tables, avoid interference between the piping/fittings and the mounting surface because of its thinner construction.

● Mounting workpieces

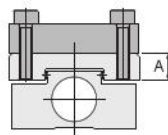

Model	Mounting screw	Max. tightening torque N·m [in·lbf]	Maximum screwing depth of A mm [in]
MGT□6	M3×0.5	0.63 [5.576]	4 [0.157]
MGT□8	M3×0.5	0.63 [5.576]	5 [0.197]
MGT□10	M3×0.5	0.63 [5.576]	5 [0.197]
MGT□12	M4×0.7	1.5 [13.277]	7 [0.276]
MGT□16	M4×0.7	1.5 [13.277]	8.5 [0.335]
MGT□20	M5×0.8	3 [26.553]	10 [0.394]



The length of the workpiece mounting screws should be below the maximum thread depth. Long screws will bump against the cylinder body, causing damage to the cylinder.

● Mounting cylinders

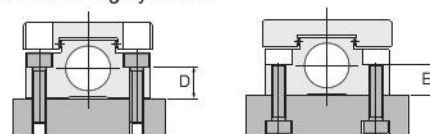

Model	Mounting screw	Max. tightening torque N·m [in·lbf]	D mm [in]
MGT□6	M2.5×0.45	0.65 [5.753]	5 [0.197]
MGT□8	M2.5×0.45	0.65 [5.753]	5.5 [0.217]
MGT□10	M3×0.5	1.14 [10.090]	7 [0.276]
MGT□12	M4×0.7	2.7 [23.898]	6 [0.236]
MGT□16	M4×0.7	2.7 [23.898]	9 [0.354]
MGT□20	M5×0.8	5.4 [47.795]	12 [0.472]

Model	Mounting screw	Max. tightening torque N·m [in·lbf]	E mm [in]
MGT□6	M3×0.5	1.14 [10.090]	5 [0.197]
MGT□8	M3×0.5	1.14 [10.090]	5.5 [0.217]
MGT□10	M4×0.7	2.7 [23.898]	7 [0.276]
MGT□12	M5×0.8	5.4 [47.795]	6 [0.236]
MGT□16	M5×0.8	5.4 [47.795]	9 [0.354]
MGT□20	M6×1	9.2 [81.429]	12 [0.472]

Stroke adjustment

The stroke becomes shorter when turning the shock absorber or stopper bolt to the right (clockwise) on both the entry side and the exit side. After completing the adjustment, set it by tightening the lock nuts.

When mounting the shock absorber, the hex nut always uses the following maximum tightening torque guidelines. Tightening with excessive force may result in damage.

N·m [in·lbf]

Model	Max. tightening torque
KSHJ4×3	0.5 [4.426]
KSHJ6×4	0.85 [7.523]
KSHJ8×4	2.5 [22.128]
KSHJ10×6	6.5 [57.532]

Recommended fittings

For piping used with the Mini Guide Tables, the quick fitting and speed controller with quick fitting shown below are recommended.

- $\phi 6$ [0.236] to $\phi 10$ [0.394]
 TS2-M3M (Straight) TSH2-M3M (Hexagon socket head straight)
 TL2-M3M (Elbow) SCC2-M3-□ (Elbow)

- $\phi 12$ [0.472] to $\phi 20$ [0.787]
 SSF4-M5-□ (Free type)

Note: For details about the speed controller with quick fitting, refer to the general catalog.

Mounting the sensor rail and magnet

The Mini Guide Tables has sensor rails and tapped holes for magnet mounting on both sides so that the sensor rail position can be changed or attached at a later time. When securing crews, tighten them at a suitable tightening torque within the allowable torque range. Always attach the plug for the piping connection port at the sensor rail side. When changing the plug position, apply sealant to the plug threads before screwing in. Install the plug at an intermediate position between the head protruding from the mounting surface and bumping against the bottom. Prevent sealant from entering inside the slider. This could lead to early shutdown of some functions or a sudden degradation of performance, and result in a reduced operating life.

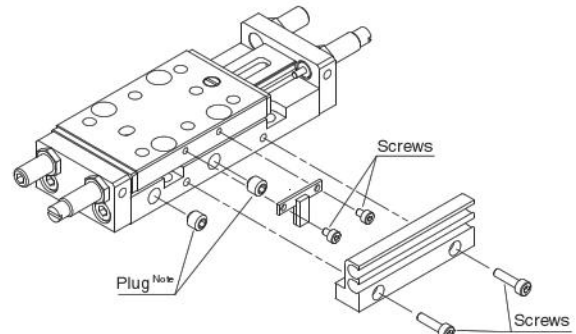

Note: Always apply sealant to the plug threads before screwing plugs in.

Mounting screw	Max. tightening torque N·m [in·lbf]
M2×0.4	0.30 [2.655]
M2.5×0.45	0.65 [5.753]

Accuracy

Mounting parallelism (Surface C against surface A and Surface D against surface B) mm [in]

	Stroke			
	10	20	30	50
MGT□6	0.03 [0.001]	0.03 [0.001]	—	—
MGT□8	0.03 [0.001]	0.03 [0.001]	—	—
MGT□10	0.03 [0.001]	0.03 [0.001]	0.03 [0.001]	—
MGT□12	—	0.03 [0.001]	0.03 [0.001]	0.03 [0.001]
MGT□16	—	0.03 [0.001]	0.03 [0.001]	0.03 [0.001]
MGT□20	—	0.03 [0.001]	0.03 [0.001]	0.03 [0.001]

Traveling parallelism (Surface C against surface A and Surface D against surface B) mm [in]

	Stroke			
	10	20	30	50
MGT□6	0.005 [0.0002]	0.005 [0.0002]	—	—
MGT□8	0.005 [0.0002]	0.005 [0.0002]	—	—
MGT□10	0.005 [0.0002]	0.005 [0.0002]	0.005 [0.0002]	—
MGT□12	—	0.005 [0.0002]	0.005 [0.0002]	0.005 [0.0002]
MGT□16	—	0.005 [0.0002]	0.005 [0.0002]	0.005 [0.0002]
MGT□20	—	0.005 [0.0002]	0.005 [0.0002]	0.005 [0.0002]

mm [in]	
Model	MGT□6 to □20
Dimensional tolerance of E	±0.05 [0.002]
Dimensional tolerance of F	±0.05 [0.002]
Dimensional tolerance of G	±0.05 [0.002]

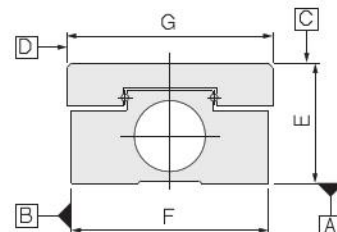

Handling Instructions and Precautions

Allowable load range

Standard (with metal stopper)

Model	MGT□6	MGT□8	MGT□10	MGT□12	MGT□16	MGT□20
Allowable kinetic energy J [ft·lbf]	0.002 [0.001]	0.004 [0.003]	0.006 [0.004]	0.012 [0.009]	0.020 [0.015]	0.030 [0.022]

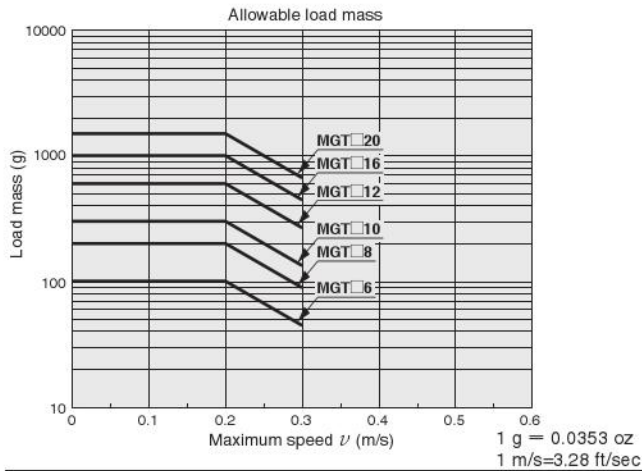

With shock absorber

Model	MGT□6	MGT□8	MGT□10	MGT□12	MGT□16	MGT□20
Allowable kinetic energy J [ft·lbf]	0.014 [0.010]	0.027 [0.020]	0.045 [0.033]	0.067 [0.049]	0.135 [0.100]	0.225 [0.166]

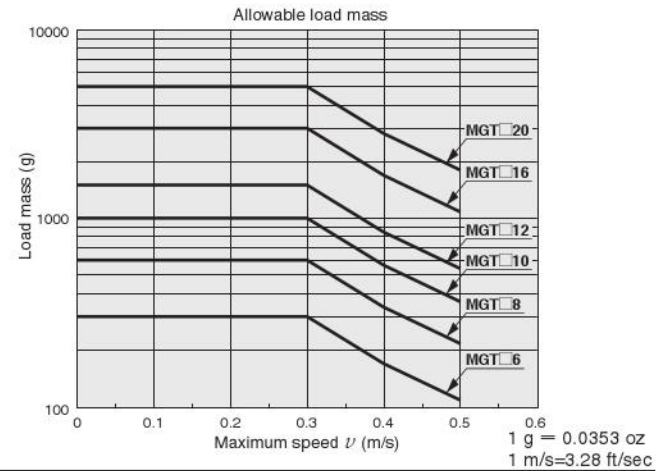

Allowable moment

The Mini Guide Tables can be used with directly applying load. In this case, however, the load and moment should not exceed the values listed to the right. Pay attention if load is applied at the offset point from the guide portion in the stroke movement, the thrust force of the mini guide table causes larger moment.

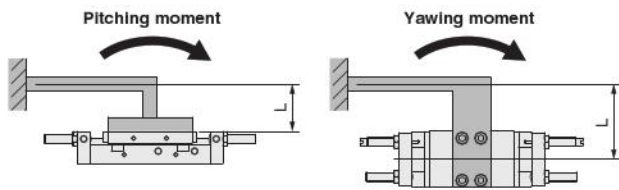

● Direction of moment

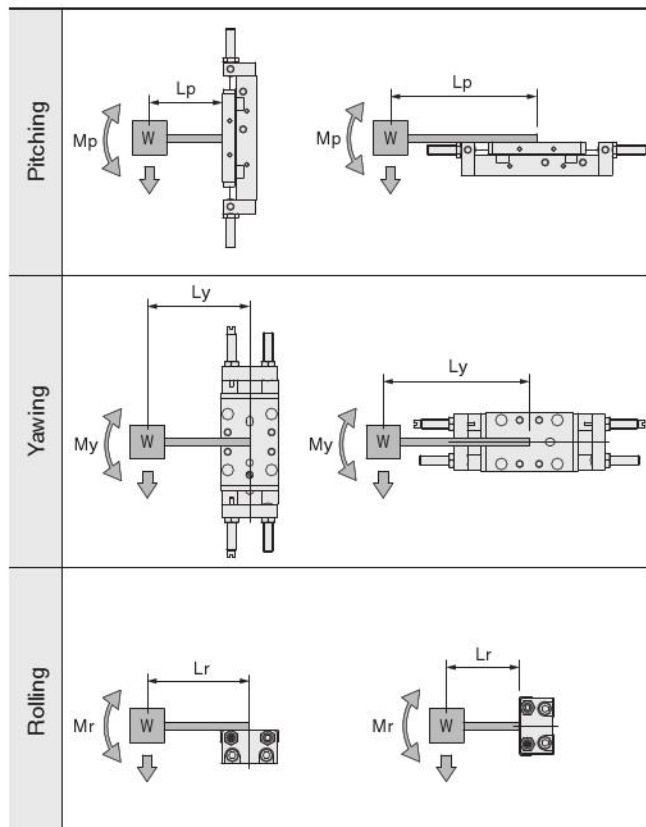

Note: The center of moment should be measured from the guide center in the diagrams.

● Allowable moment

Model	Stroke mm [in]	N·m [in·lbf]		
		Mp	My	Mr
MGT□6	10 [0.394]	0.5 [4.426]	0.6 [5.311]	0.3 [2.655]
	20 [0.787]	0.6 [5.311]	0.7 [6.196]	0.3 [2.655]
MGT□8	10 [0.394]	0.5 [4.426]	0.6 [5.311]	0.6 [5.311]
	20 [0.787]	0.6 [5.311]	0.7 [6.196]	0.6 [5.311]
MGT□10	10 [0.394]	0.6 [5.311]	0.7 [6.196]	0.6 [5.311]
	20 [0.787]	0.6 [5.311]	0.8 [7.081]	0.6 [5.311]
	30 [1.181]	0.7 [6.196]	0.9 [7.966]	0.6 [5.311]
MGT□12	20 [0.787]	2.6 [23.013]	3.1 [27.438]	2.8 [24.783]
	30 [1.181]	2.9 [25.668]	3.5 [30.979]	2.8 [24.783]
	50 [1.969]	3.6 [31.864]	4.3 [38.059]	2.8 [24.783]
MGT□16	20 [0.787]	3.6 [31.864]	4.3 [38.059]	4.6 [40.715]
	30 [1.181]	4.0 [35.404]	4.8 [42.485]	4.6 [40.715]
MGT□20	50 [1.969]	4.9 [43.370]	5.8 [51.336]	4.6 [40.715]
	20 [0.787]	4.1 [36.289]	4.9 [43.370]	5.8 [51.336]
	30 [1.181]	4.5 [39.830]	5.4 [47.795]	5.8 [51.336]
MGT□20	50 [1.969]	5.4 [47.795]	6.5 [57.532]	5.8 [51.336]

Remark: The allowable moment includes the safety factor of 10 with respect to the calculated value of the guide. However, the calculated values are not guaranteed values.

● Guide calculation values (reference values)

Model	Stroke mm [in]	Basic dynamic rated load CN [lbf]	Basic static rated load Co N [lbf]	Static rated moment N·m [in·lbf]		
				Mp	My	Mr
MGT□6	10 [0.394]	633 [142.3]	1060 [238]	5.0 [44.255]	6.0 [53.106]	3.4 [30.093]
	20 [0.787]	636 [143.0]	1060 [238]	5.7 [50.451]	6.9 [61.072]	3.4 [30.093]
MGT□8	10 [0.394]	633 [142.3]	1060 [238]	5.0 [44.255]	6.0 [53.106]	5.5 [48.681]
	20 [0.787]	636 [143.0]	1060 [238]	5.7 [50.451]	6.9 [61.072]	5.5 [48.681]
MGT□10	10 [0.394]	636 [143.0]	1060 [238]	5.7 [50.451]	6.9 [61.072]	5.5 [48.681]
	20 [0.787]	639 [143.7]	1060 [238]	6.4 [56.646]	7.8 [69.038]	5.5 [48.681]
	30 [1.181]	642 [144.3]	1060 [238]	7.1 [62.842]	8.7 [77.004]	5.5 [48.681]
MGT□12	20 [0.787]	2620 [589]	3950 [888]	26.3 [232.781]	31.3 [277.036]	27.7 [245.173]
	30 [1.181]	2630 [591]	3950 [888]	28.9 [255.794]	34.5 [305.360]	27.7 [245.173]
	50 [1.969]	2650 [596]	3950 [888]	35.9 [317.751]	42.8 [378.823]	27.7 [245.173]
MGT□16	20 [0.787]	3570 [803]	4850 [1090]	35.6 [315.096]	42.5 [376.168]	46.1 [408.031]
	30 [1.181]	3580 [805]	4850 [1090]	40.0 [354.040]	47.6 [421.308]	46.1 [408.031]
	50 [1.969]	3610 [812]	4850 [1090]	48.7 [431.044]	58.0 [513.358]	46.1 [408.031]
MGT□20	20 [0.787]	3790 [852]	5290 [1189]	40.9 [362.006]	48.8 [431.929]	58.2 [515.128]
	30 [1.181]	3800 [854]	5290 [1189]	45.0 [398.295]	53.7 [475.299]	58.2 [515.128]
	50 [1.969]	3830 [861]	5290 [1189]	54.2 [479.724]	64.6 [571.775]	58.2 [515.128]

Displacement angle of the table by bending moment

(Reference value)

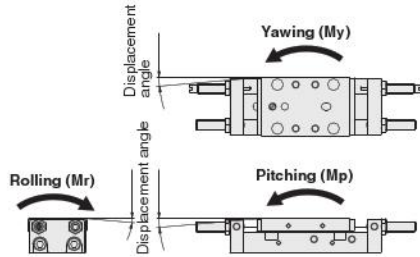

● $\phi 6$ [0.236] to $\phi 10$ [0.394]

1 N•m=8.851 in•lb

Pitching (Mp)

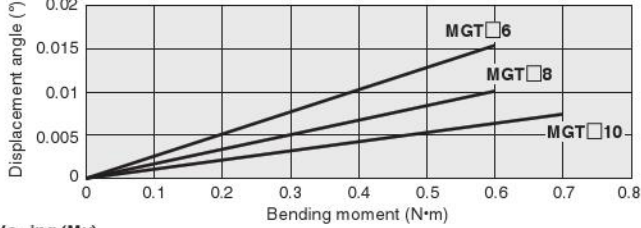

Yawing (My)

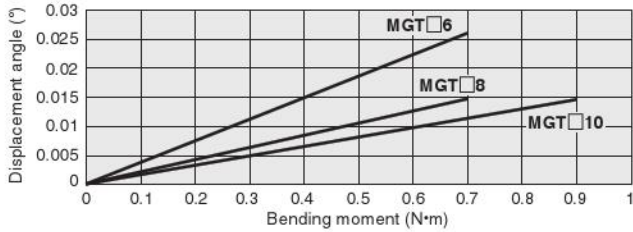

Rolling (Mr)

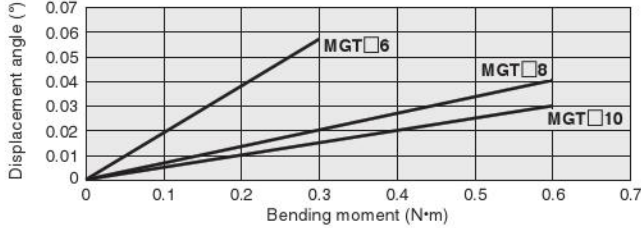

● $\phi 12$ [0.472] to $\phi 20$ [0.787]

1 N•m=8.851 in•lb

Pitching (Mp)

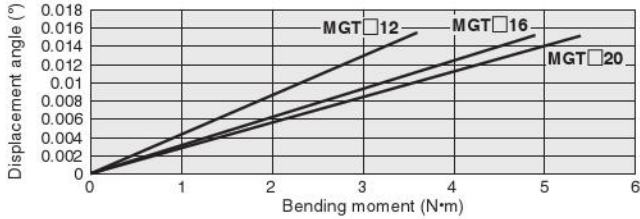

Yawing (My)

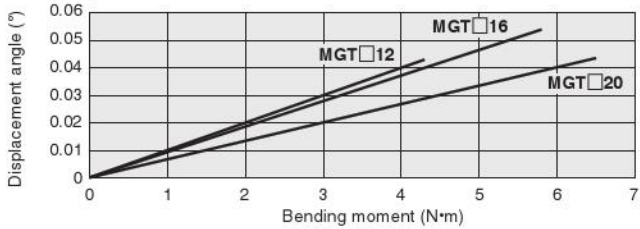

Rolling (Mr)

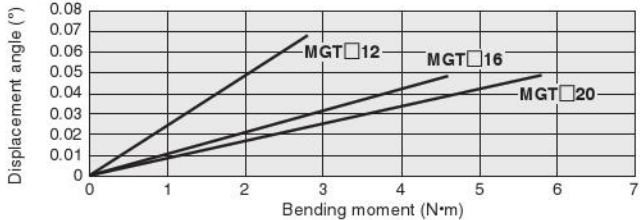

MINI GUIDE TABLES

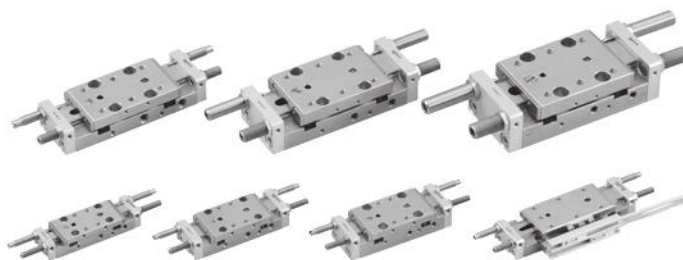

Specifications

Item	Model	MGT□6	MGT□8	MGT□10	MGT□12	MGT□16	MGT□20
Bore size	mm [in]	6 [0.236]	8 [0.315]	10 [0.394]	12 [0.472]	16 [0.630]	20 [0.787]
Operating type		Double acting type					
Media		Air					
Operating pressure range	MPa [psi]	0.2 to 0.7 [29 to 102]	0.15 to 0.7 [22 to 102]		0.1 to 0.7 [15 to 102]		
Proof pressure	MPa [psi]	1.05 [152]					
Operating temperature range	°C [°F]	0 to 60 [32 to 140]					
Operating speed range	Standard (metal stopper)	30 to 300 [1.181 to 11.8]			20 to 300 [0.787 to 11.8]		
	Shock absorber	30 to 500 [1.181 to 19.7]			20 to 500 [0.787 to 19.7]		
Cushion	Standard (metal stopper)	None					
	Shock absorber	Shock absorber type (optional)					
Port size		M3×0.5			M5×0.8		
Lubrication	Cylinder portion	Not required (if lubricated, use equivalent of turbine oil 1 (ISO VG32))					
	Guide portion	Required (CGL grease, made by Nippon Thompson CO., LTD.) ^{Note}					
Repeatability	mm [in]	±0.02 [0.001]					
Stroke adjustment range	Standard (metal stopper)	-8 to 0 [-0.315 to 0]	-10 to 0 [-0.394 to 0]	-10 to 0 [-0.394 to 0]	-10 to 0 [-0.394 to 0]	-10 to 0 [-0.394 to 0]	-10 to 0 [-0.394 to 0]
	Shock absorber	-8 to 0 [-0.315 to 0]	-10 to 0 [-0.394 to 0]	-10 to 0 [-0.394 to 0]	-10 to 0 [-0.394 to 0]	-10 to 0 [-0.394 to 0]	-10 to 0 [-0.394 to 0]
Number of available sensor switches (optional)		2 pieces					

Note: Apply lithium soap-based grease on the raceway surface of the track rail in the guide portion every six months or 3 million operations.

Remark 1: For the specifications and details of the shock absorber, see the General Catalog and Shock Absorber Catalog.

2: Touching the body of the product with bare hands may cause rusting because of salt content in sweat. It is advisable to wear gloves. We recommend wearing gloves.

Cylinder Thrust

Bore size mm [in]	Piston rod diameter mm [in]	Operation direction	Pressure area mm ² [in ²]	Air pressure MPa [psi]							N [lbf]
				0.1 [14.500]	0.2 [29.000]	0.3 [43.500]	0.4 [58.000]	0.5 [72.500]	0.6 [87.000]	0.7 [101.500]	
6 [0.236]	3 [0.118]	Push side	28.2 [4.371]	—	5.6 [1.259]	8.5 [1.911]	11.3 [2.540]	14.1 [3.170]	16.9 [3.799]	19.7 [4.429]	
		Pull side	21.2 [0.033]	—	4.2 [0.944]	6.4 [1.439]	8.5 [1.911]	10.6 [2.383]	12.7 [2.855]	14.8 [3.327]	
8 [0.315]	4 [0.157]	Push side	50.3 [0.078]	—	10.1 [2.271]	15.1 [3.395]	20.1 [4.519]	25.2 [5.665]	30.2 [6.789]	35.2 [7.913]	
		Pull side	37.7 [0.058]	—	7.5 [1.686]	11.3 [2.540]	15.1 [3.395]	18.8 [4.226]	22.6 [5.081]	26.4 [5.935]	
10 [0.394]	5 [0.197]	Push side	78.5 [0.122]	—	15.7 [3.530]	23.6 [5.305]	31.4 [7.059]	39.3 [8.835]	47.1 [10.589]	55.0 [12.364]	
		Pull side	58.9 [0.091]	—	11.8 [2.653]	17.7 [3.979]	23.6 [5.305]	29.4 [6.609]	35.3 [7.936]	41.2 [9.262]	
12 [0.472]	6 [0.236]	Push side	113.0 [0.2]	11.3 [2.540]	22.6 [5.081]	33.9 [7.621]	45.2 [10.161]	56.5 [12.702]	67.8 [15.242]	79.1 [17.782]	
		Pull side	84.8 [0.131]	8.5 [1.911]	17.0 [3.822]	25.4 [5.710]	33.9 [7.621]	42.4 [9.532]	50.9 [11.443]	59.3 [13.331]	
16 [0.630]	8 [0.315]	Push side	201.0 [0.3]	20.1 [4.519]	40.2 [9.037]	60.3 [13.556]	80.4 [18.075]	100.5 [22.6]	120.6 [27.1]	140.7 [31.6]	
		Pull side	150.7 [0.2]	15.1 [3.395]	30.1 [6.767]	45.2 [10.161]	60.3 [13.556]	75.4 [16.951]	90.4 [20.323]	105.5 [23.7]	
20 [0.787]	10 [0.394]	Push side	314.0 [0.5]	31.4 [7.059]	62.8 [14.118]	94.2 [21.177]	125.6 [28.2]	157.0 [35.3]	188.4 [42.4]	219.8 [49.4]	
		Pull side	235.5 [0.4]	23.6 [5.305]	47.1 [10.589]	70.7 [15.894]	94.2 [21.177]	117.8 [26.5]	141.3 [31.8]	164.9 [37.1]	

Bore Size and Stroke

Bore size	Standard strokes	
	mm [in]	
6 [0.236]	10 [0.394], 20 [0.787]	
8 [0.315]	10 [0.394], 20 [0.787]	
10 [0.394]	10 [0.394], 20 [0.787], 30 [1.181]	
12 [0.472]	20 [0.787], 30 [1.181], 50 [1.969]	
16 [0.630]	20 [0.787], 30 [1.181], 50 [1.969]	
20 [0.787]	20 [0.787], 30 [1.181], 50 [1.969]	

Mass

● Mass of standard cylinders

Model	Stroke mm [in]	Mass of body	Additional mass	
			Magnet and sensor rail	Shock absorbers (2 included)
MGT□6	10 [0.394]	70 [2.469]	6 [0.212]	3 [0.106]
	20 [0.787]	95 [3.351]	6 [0.212]	3 [0.106]
MGT□8	10 [0.394]	103 [3.6]	6 [0.212]	3 [0.106]
	20 [0.787]	138 [4.9]	6 [0.212]	3 [0.106]
MGT□10	10 [0.394]	134 [4.7]	6 [0.212]	3 [0.106]
	20 [0.787]	175 [6.2]	6 [0.212]	3 [0.106]
	30 [1.181]	218 [7.7]	7 [0.247]	3 [0.106]
MGT□12	20 [0.787]	256 [9.0]	13 [0.459]	8 [0.282]
	30 [1.181]	320 [11.3]	15 [0.529]	8 [0.282]
	50 [1.969]	435 [15.3]	20 [0.705]	8 [0.282]
MGT□16	20 [0.787]	409 [14.4]	13 [0.459]	18 [0.635]
	30 [1.181]	500 [17.6]	15 [0.529]	18 [0.635]
	50 [1.969]	673 [23.7]	20 [0.705]	18 [0.635]
MGT□20	20 [0.787]	610 [21.5]	13 [0.459]	38 [1.340]
	30 [1.181]	740 [26.1]	15 [0.529]	38 [1.340]
	50 [1.969]	986 [34.8]	20 [0.705]	38 [1.340]

● Sensor switch (1 included)

	g [oz]
ZE □□□ A	15 [0.529]
ZE □□□ B	35 [1.235]
ZE □□□ G	15 [0.529]

● Shock absorber (with one installation nut)

	g [oz]
KSHJ4 × 3-02	1.5 [0.053]
KSHJ4 × 3-01	1.5 [0.053]
KSHJ6 × 4-01	4 [0.141]
KSHJ8 × 4-01	9 [0.317]
KSHJ10 × 6-01	19 [0.670]

Order Codes

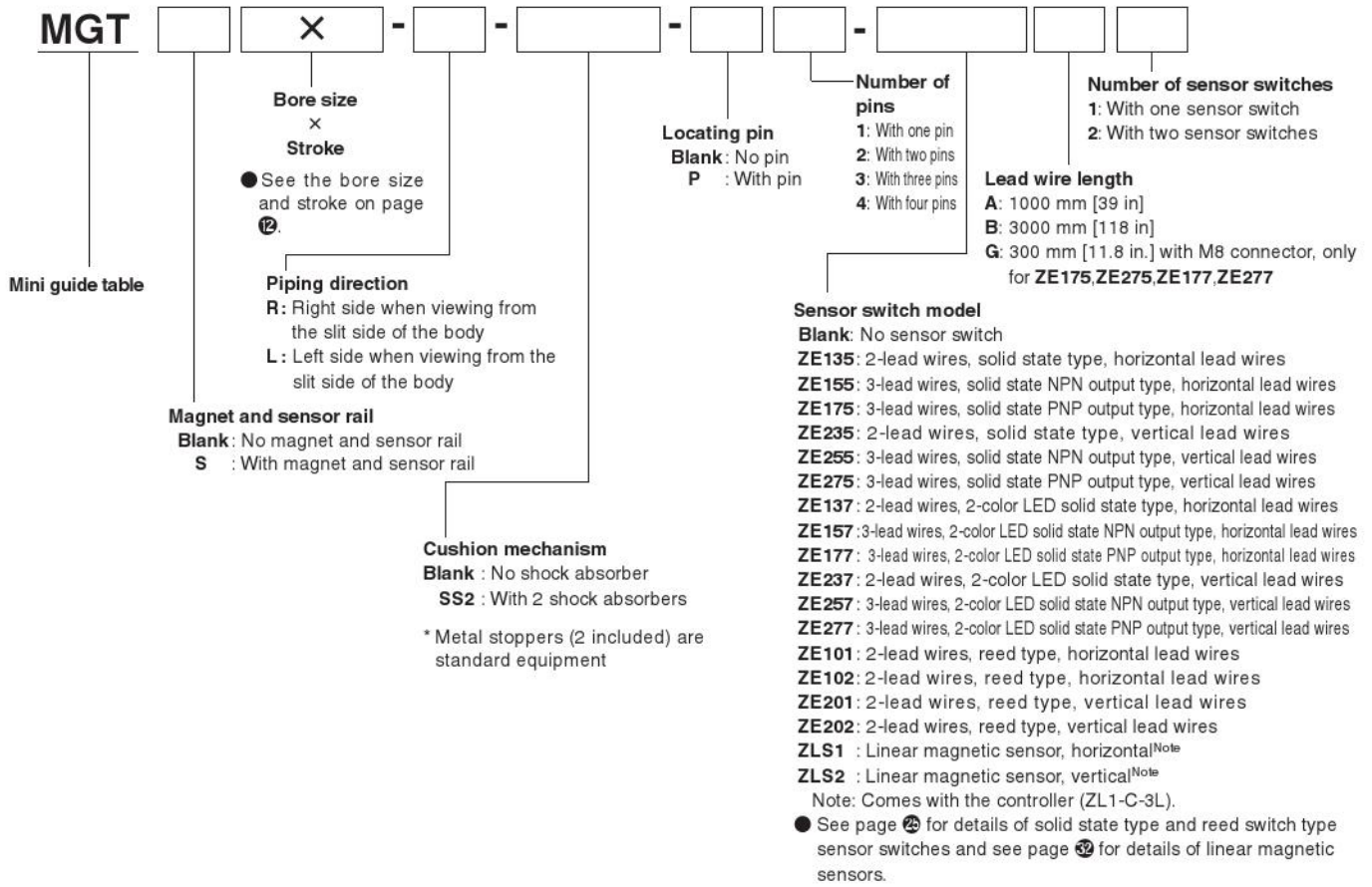

Additional parts

● Sensor rail

S-MGT []

Applicable cylinder bore size × stroke

- 1: 6×10 [0.236×0.394], 8×10 [0.315×0.394], 10×10 [0.394×0.394]
- 2: 6×20 [0.236×0.787], 8×20 [0.315×0.787], 10×20 [0.394×0.787]
- 3: 10×30 [0.394×1.181]
- 4: 12×20 [0.472×0.787], 16×20 [0.630×0.787], 20×20 [0.787×0.787]
- 5: 12×30 [0.472×1.181], 16×30 [0.630×1.181], 20×30 [0.787×1.181]
- 6: 12×50 [0.472×1.969], 16×50 [0.630×1.969], 20×50 [0.787×1.969]



● Magnet

M-MGA []

Applicable cylinder bore size

- 2: 6 [0.236], 8 [0.315], 10 [0.394]
- 12 [0.472], 16 [0.630], 20 [0.787]



● Locating pin

P-MGA []

Applicable cylinder bore size

- 1: 6 [0.236], 8 [0.315], 10 [0.394]
- 2: 12 [0.472], 16 [0.630], 20 [0.787]



Remark: For the dimensions of the additional parts (sensor rail, magnet, and locating pin), see page 29.

● Stopper and shock absorber

Bore size	Metal stopper type	Shock absorber type
6 [0.236]	CRK645	KSHJ4×3-02
8 [0.315]	CRK645	KSHJ4×3-01
10 [0.394]	CRK645	KSHJ4×3-01
12 [0.472]	CRK723	KSHJ6×4-01
16 [0.630]	CRK724	KSHJ8×4-01
20 [0.787]	CRK725	KSHJ10×6-01

Remark: The set includes a mounting nut.



Metal stopper



Shock absorber

Remark: For the dimensions of the metal stopper, see page 29. Also, see the catalog for shock absorbers or the general catalog for dimensions and specifications for each shock absorber.

Inner Construction

MGT□6-8

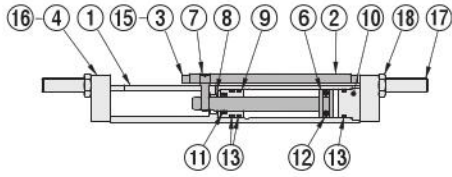

MGTS (with magnet sensor rail)

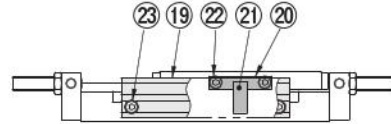

MGT□10

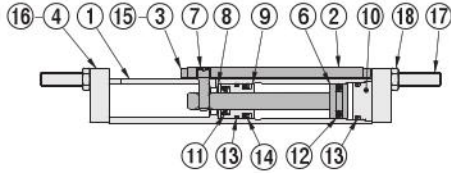

MGT□6 to 20-SS2(with shock absorber)

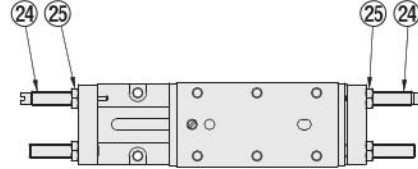

MGT□12 to 20

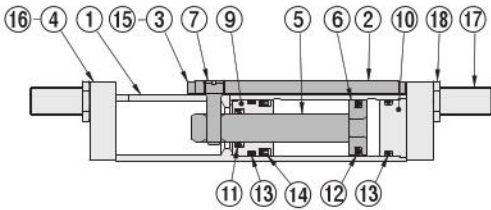

Locating pin

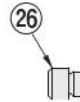

Major parts and materials

No.	Parts	Model	MGT□6	MGT□8	MGT□10	MGT□12	MGT□16	MGT□20
①	Body		Stainless steel (heat treated)					
②	Table		Stainless steel (heat treated)					
③	Stopper		Stainless steel (heat treated, nickel plated)					
④	Bracket		Aluminum alloy (anodized)					
⑤	Piston rod		—			Stainless steel		
⑥	Piston ^{Note}		Stainless steel			Aluminum alloy (anodized)		
⑦	Connecting pins		Steel (nickel plated)					
⑧	Packing holder		Brass					
⑨	Rod cover		Aluminum alloy (special anti-abrasion coating)					
⑩	Head cover		Aluminum alloy (anodized)					
⑪	Rod seal		Synthetic rubber (NBR)					
⑫	Piston seal		Synthetic rubber (NBR)					
⑬	O-ring		Synthetic rubber (NBR)					
⑭	Seal		—			Synthetic rubber (NBR)		
⑮	Screw		Stainless steel					
⑯	Bolt		Stainless steel					
⑰	Stopper bolt		Stainless steel (heat treated)					
⑱	Nut		Stainless steel			Mild steel (zinc plated)		
⑲	Sensor rail		Aluminum alloy (anodized)					
⑳	Magnet holder		Aluminum alloy (anodized)					
㉑	Magnet		Plastic magnet					
㉒	Bolt		Stainless steel					
㉓	Bolt		Stainless steel					
㉔	Shock absorber		—					
㉕	Nut		Stainless steel			Mild steel (zinc plated)		
㉖	Locating pin		Steel (heat treated)					

Note: In MGT 6, 8 and 10, the piston and piston rod are combined as single-piece construction.

Dimensions of Bore Size $\phi 6$ [0.236] mm [in]

● MGT□6×10 (when stroke 10)

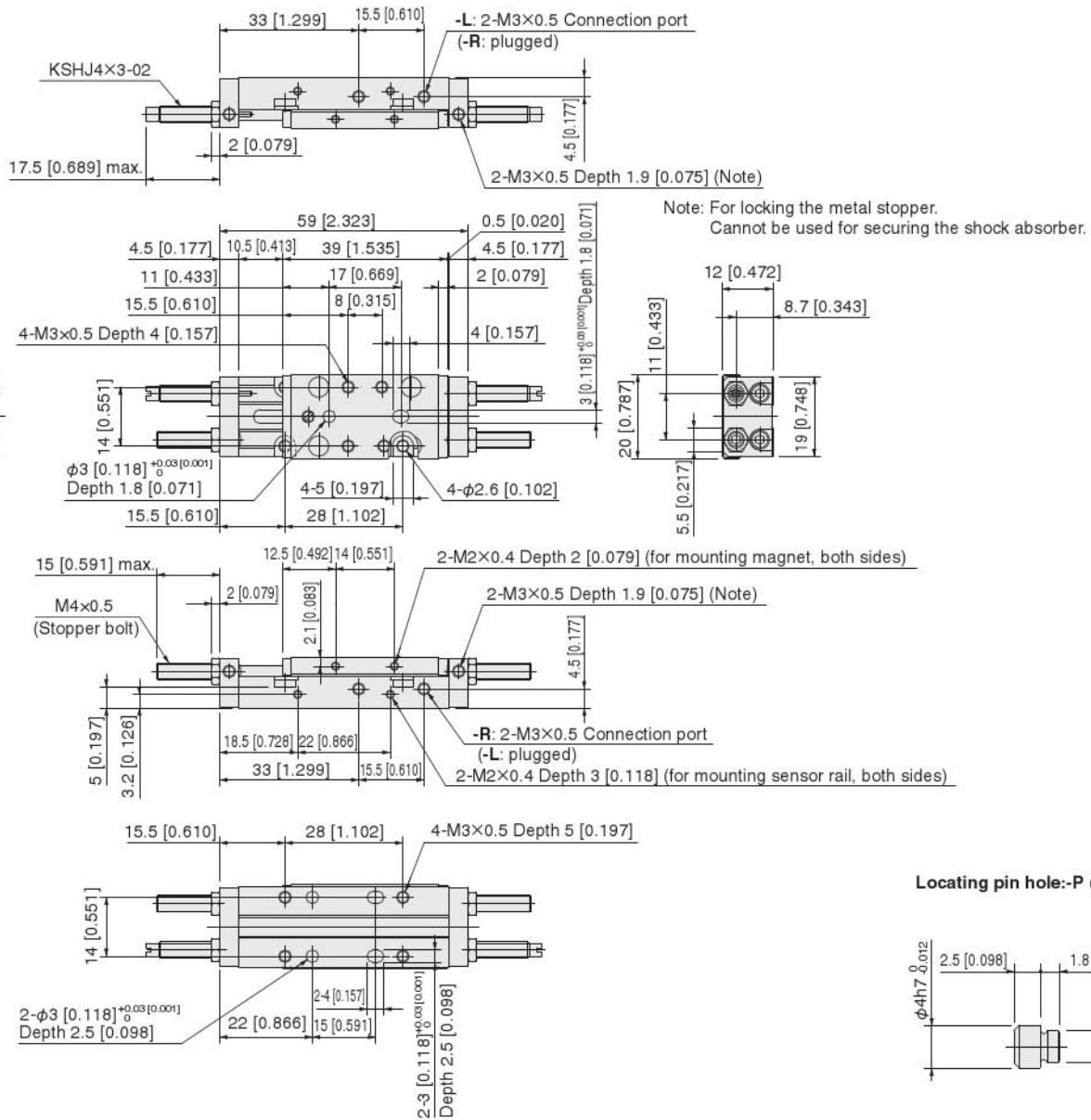

When magnet and sensor rail installed (Piping direction-R)

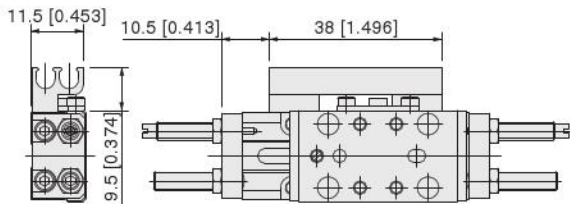

When magnet and sensor rail installed (Piping direction-L)

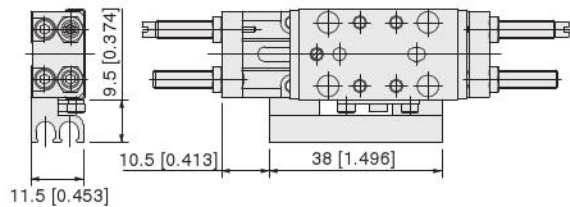

Dimensions of Bore Size $\phi 6$ [0.236] mm [in]

● MGT□6×20 (when stroke 20)

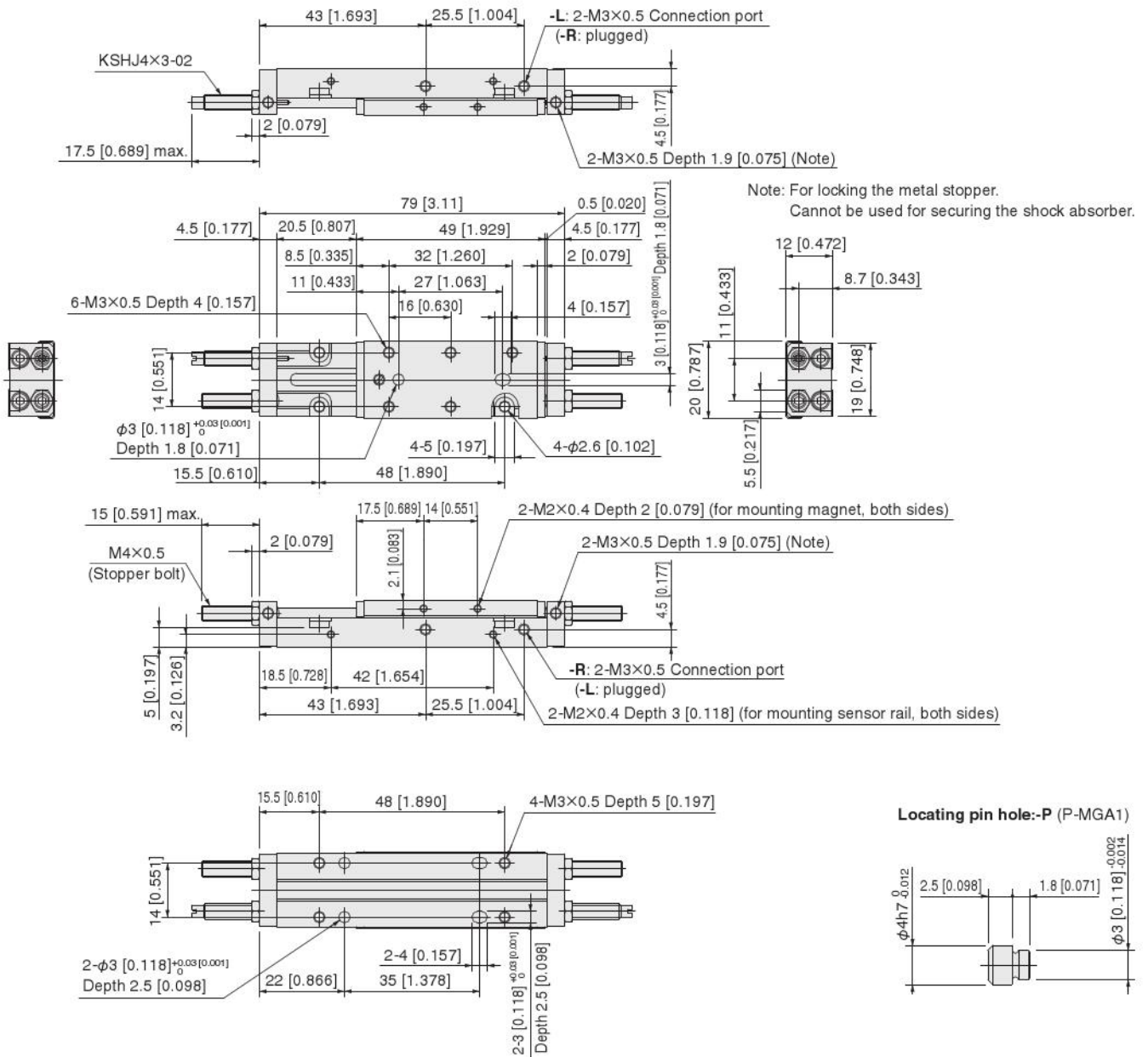

When magnet and sensor rail installed (Piping direction-R)

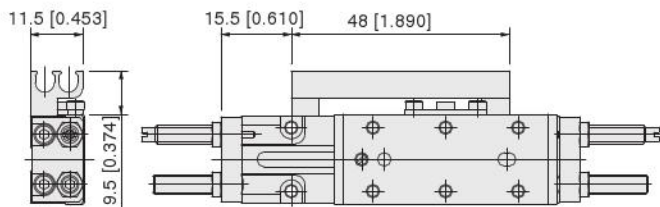

When magnet and sensor rail installed (Piping direction-L)

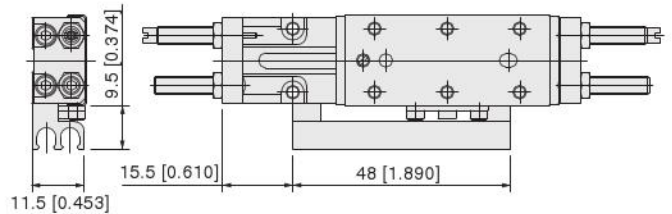

Dimensions of Bore Size $\phi 8$ [0.315] mm [in]

● MGT□8×10 (when stroke 10)

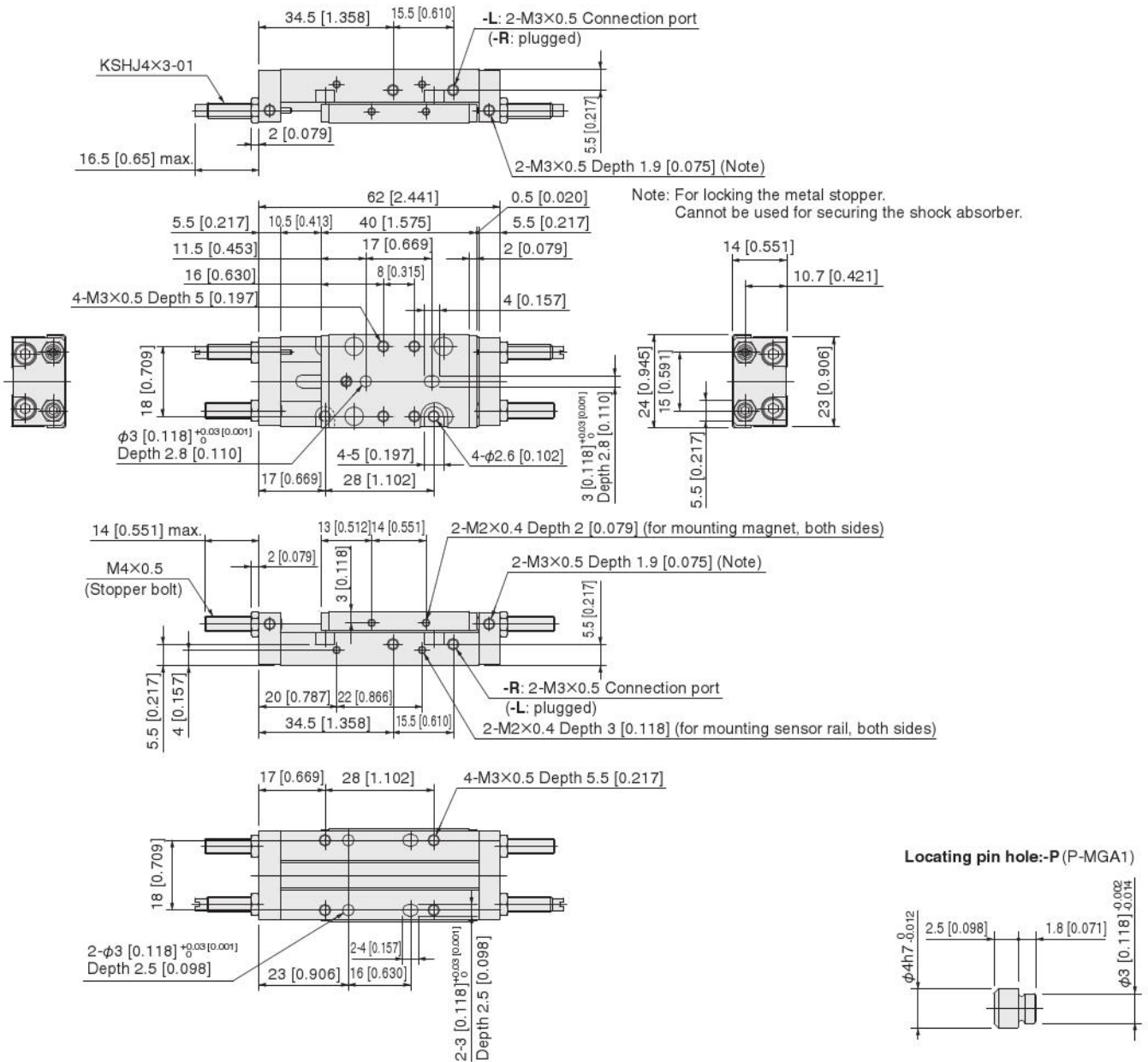

When magnet and sensor rail installed (Piping direction-R)

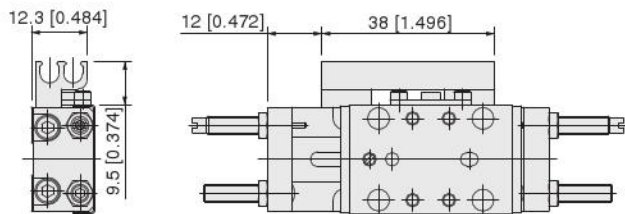

When magnet and sensor rail installed (Piping direction-L)

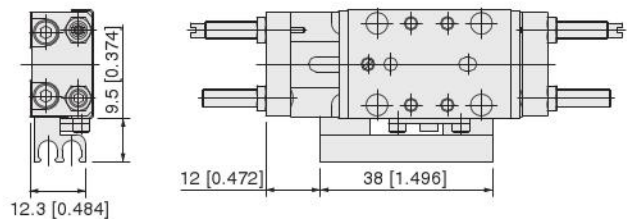

Dimensions of Bore Size $\phi 8$ [0.315] mm [in]

● MGT□8×20 (when stroke 20)

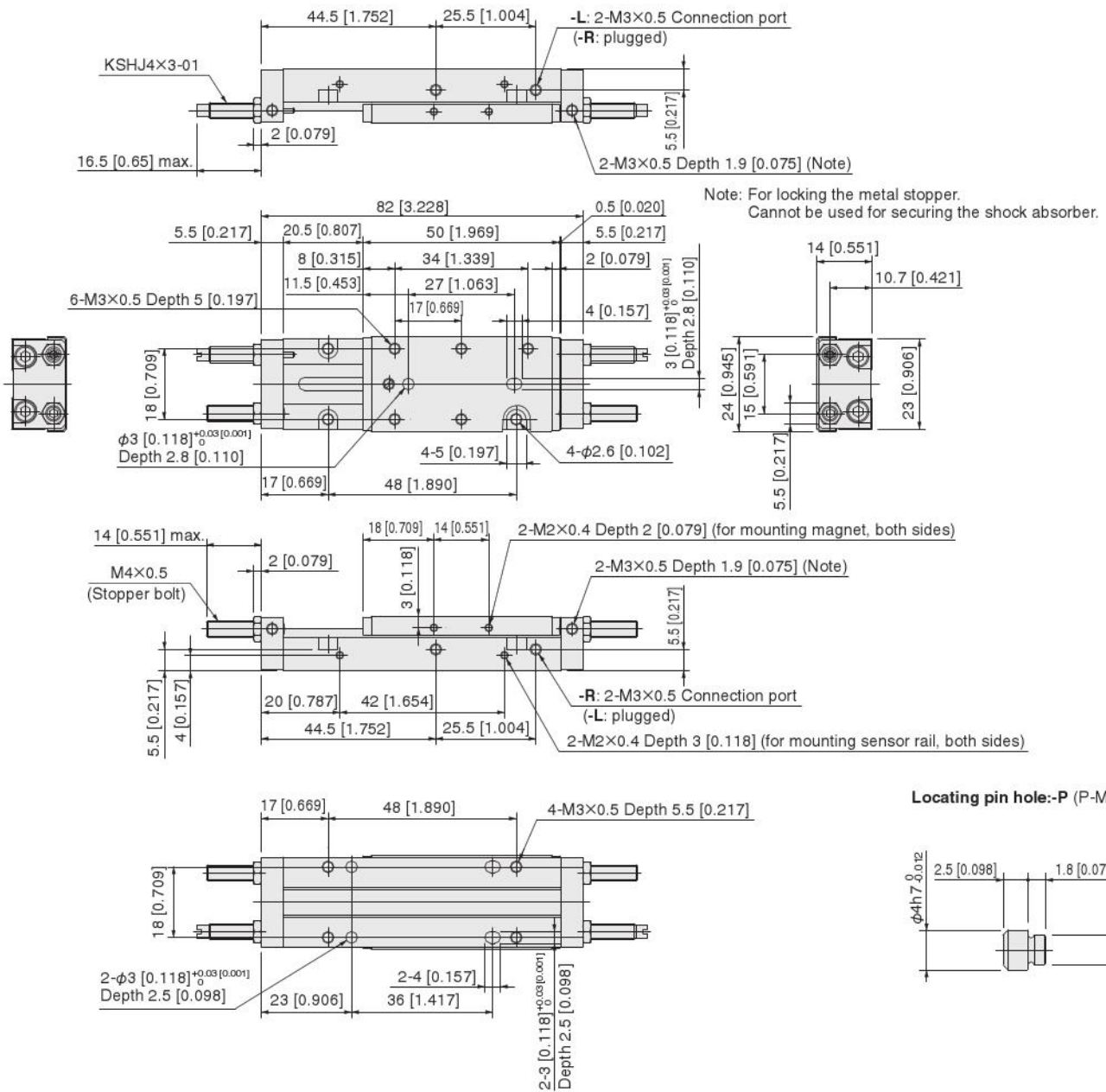

When magnet and sensor rail installed (Piping direction-R)

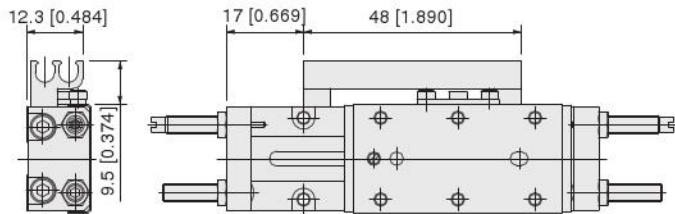

When magnet and sensor rail installed (Piping direction-L)

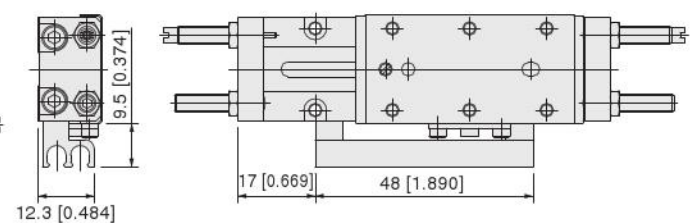

Dimensions of Bore Size $\phi 10$ [0.394] mm [in]

● MGT□10×20, MGT□10×30 (when stroke 20, stroke 30)

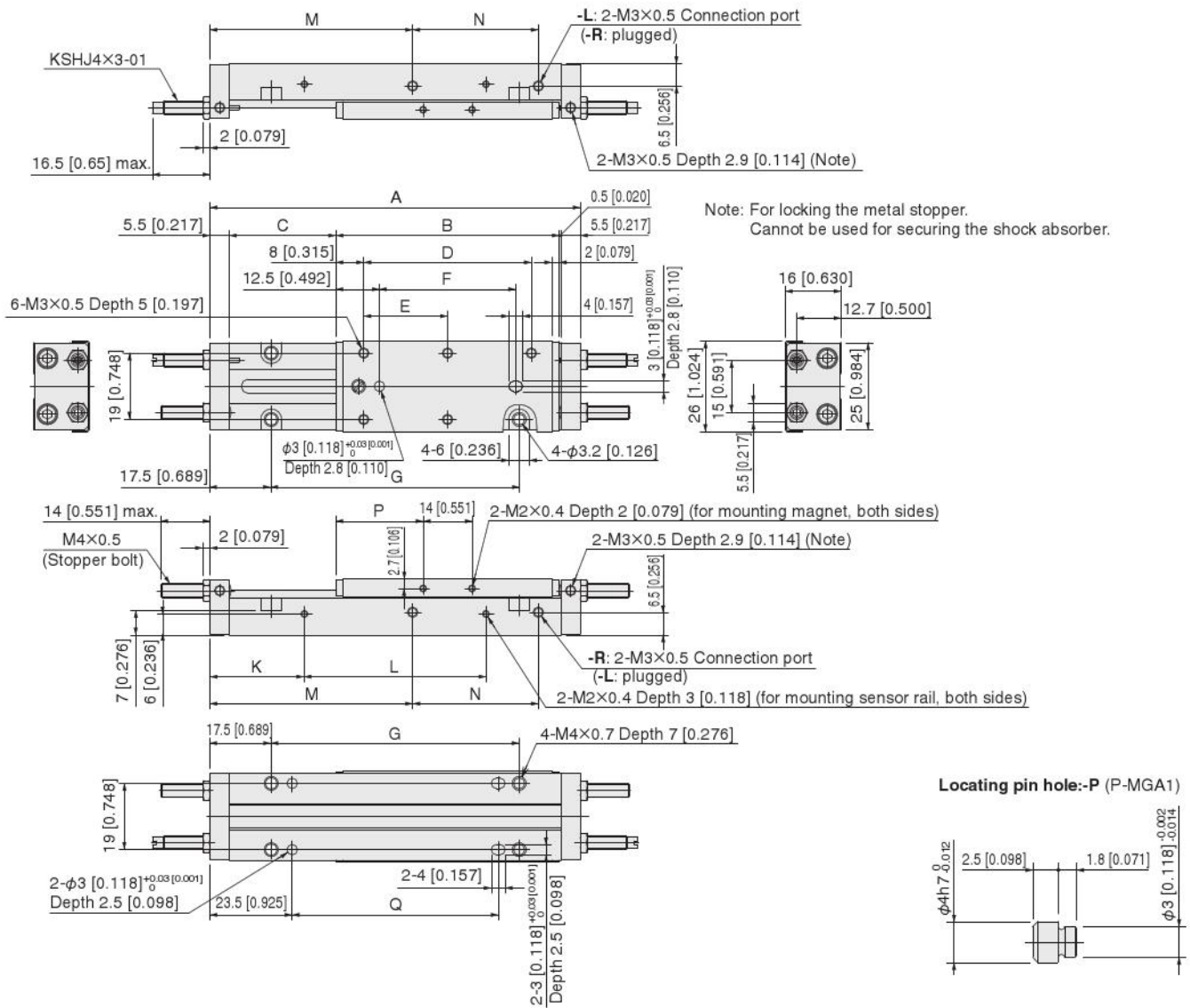

When magnet and sensor rail installed (Piping direction-R)

When magnet and sensor rail installed (Piping direction-L)

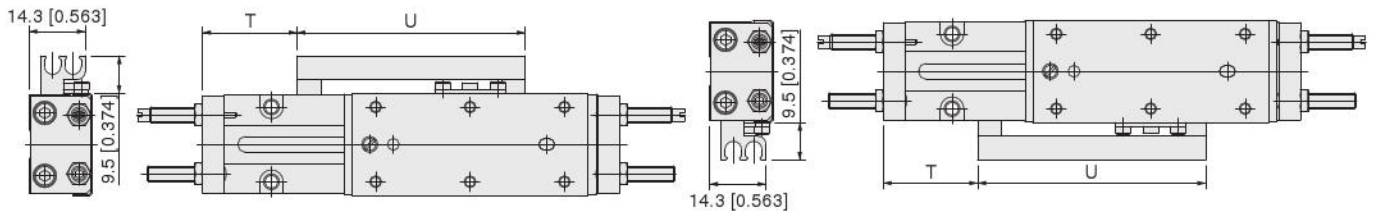

Stroke	A	B	C	D	E	F	G	K	L	M	N	P	Q	T	U
20 [0.787]	86 [3.386]	54 [2.126]	20.5 [0.807]	38 [1.496]	19 [0.748]	29 [1.142]	51 [2.008]	22 [0.866]	42 [1.654]	48 [1.890]	26 [1.024]	20 [0.787]	39 [1.535]	19 [0.748]	48 [1.890]
30 [1.181]	106 [4.1]	64 [2.520]	30.5 [1.201]	48 [1.890]	24 [0.945]	39 [1.535]	71 [2.795]	27 [1.063]	52 [2.047]	58 [2.283]	36 [1.417]	25 [0.984]	59 [2.323]	24 [0.945]	58 [2.283]

Dimensions of Bore Size $\phi 12$ [0.472] mm [in]

● MGT□12

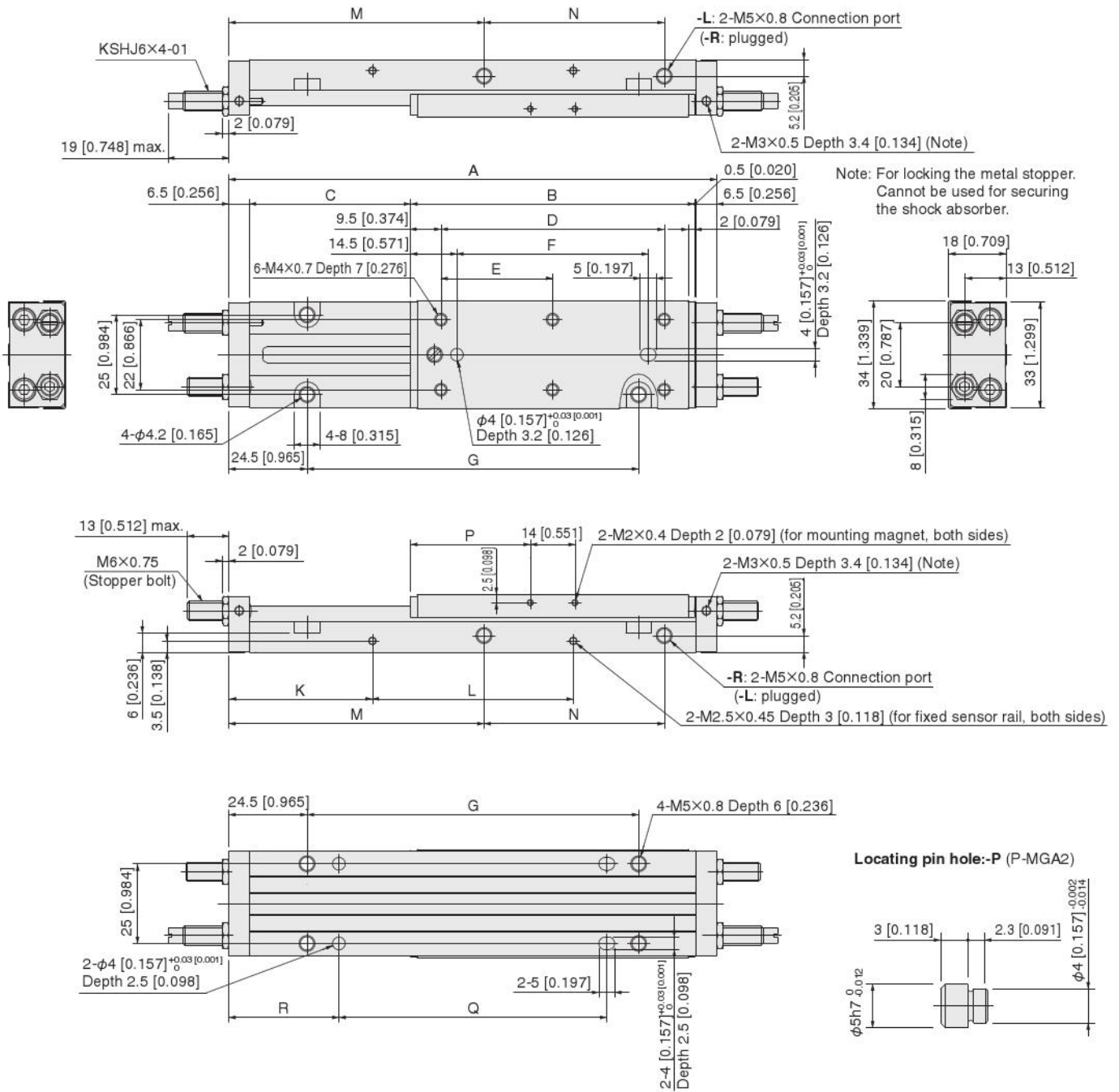

When magnet and sensor rail installed (Piping direction-R)

When magnet and sensor rail installed (Piping direction-L)

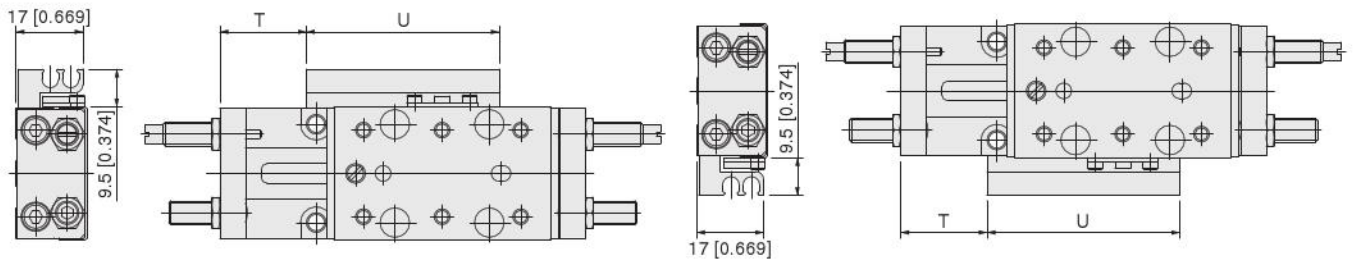

* Bolt through holes are included in the table for fixed bodies only for stroke 20.

Stroke	A	B	C	D	E	F	G	K	L	M	N	P	Q	R	T	U
20 [0.787]	93 [3.661]	59 [2.323]	20.5 [0.807]	40 [1.575]	20 [0.787]	30 [1.181]	44 [1.732]	30 [1.181]	33 [1.299]	50 [1.969]	26.5 [1.043]	22.5 [0.886]	24 [0.945]	34.5 [1.358]	22 [0.866]	49 [1.929]
30 [1.181]	113 [4.449]	69 [2.717]	30.5 [1.201]	50 [1.969]	25 [0.984]	40 [1.575]	64 [2.520]	35 [1.378]	43 [1.693]	60 [2.362]	36.5 [1.437]	27.5 [1.083]	52 [2.047]	30.5 [1.201]	27 [1.063]	59 [2.323]
50 [1.969]	153 [6.024]	89 [3.504]	50.5 [1.988]	70 [2.756]	35 [1.378]	60 [2.362]	104 [4.094]	45 [1.772]	63 [2.480]	80 [3.150]	56.5 [2.224]	37.5 [1.476]	84 [3.307]	34.5 [1.358]	37 [1.457]	79 [3.110]

Dimensions of Bore Size $\phi 16$ [0.630] mm [in]

● MGT□16

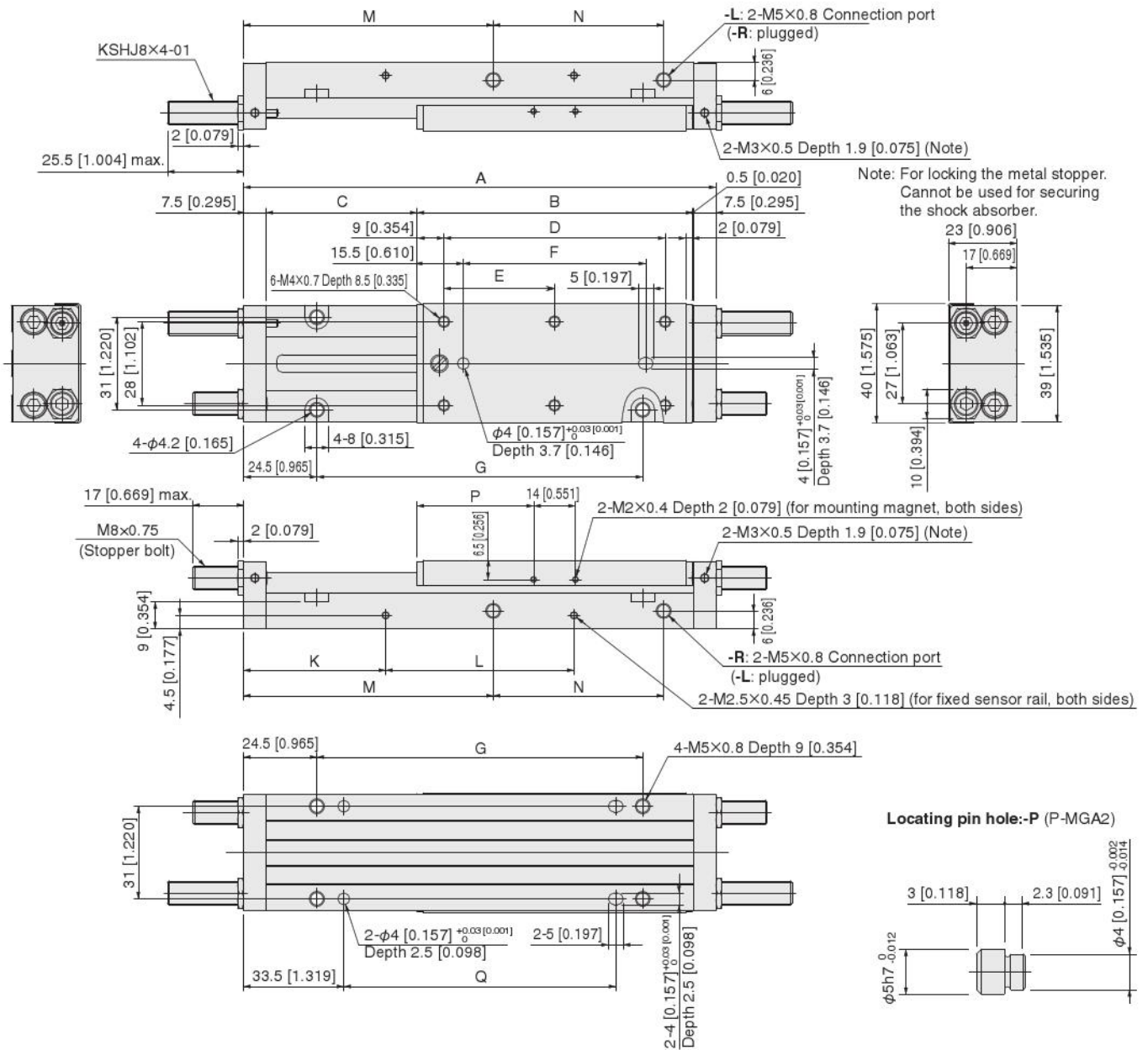

When magnet and sensor rail installed (Piping direction-R)

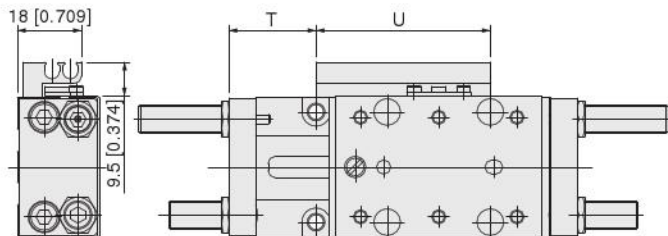

When magnet and sensor rail installed (Piping direction-L)

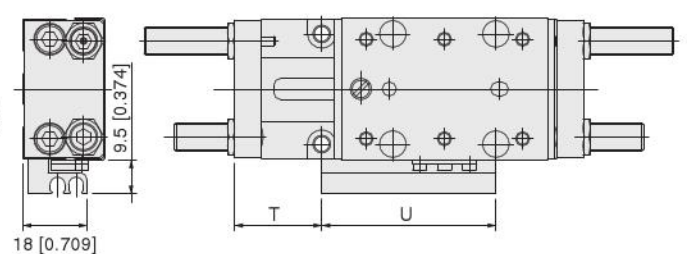

* Bolt through holes are included in the table for fixed bodies only for stroke 20.

Stroke	A	B	C	D	E	F	G	K	L	M	N	P	Q	T	U
20 [0.787]	98 [3.858]	62 [2.441]	20.5 [0.807]	44 [1.732]	22 [0.866]	31 [1.220]	49 [1.929]	32.5 [1.280]	33 [1.299]	53.5 [2.106]	27 [1.063]	24 [0.945]	31 [1.220]	24.5 [0.965]	49 [1.929]
30 [1.181]	118 [4.646]	72 [2.835]	30.5 [1.201]	54 [2.126]	27 [1.063]	41 [1.614]	69 [2.717]	37.5 [1.476]	43 [1.693]	63.5 [2.5]	37 [1.457]	29 [1.142]	51 [2.008]	29.5 [1.161]	59 [2.323]
50 [1.969]	158 [6.2]	92 [3.622]	50.5 [1.988]	74 [2.913]	37 [1.457]	61 [2.402]	109 [4.291]	47.5 [1.870]	63 [2.480]	83.5 [3.287]	57 [2.244]	39 [1.535]	91 [3.583]	39.5 [1.555]	79 [3.110]

● Sensor rail

S-MGT1•2•3

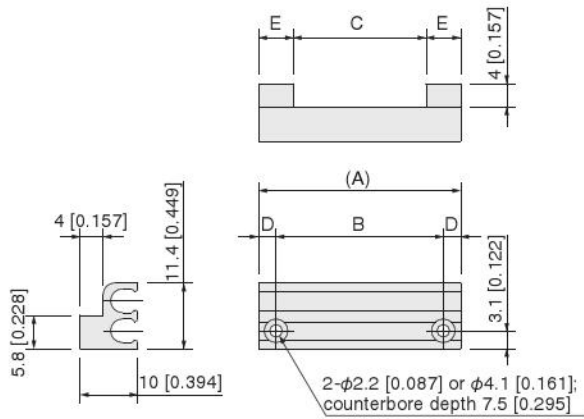

Model	A	B	C	D	E
S-MGT1	38 [1.496]	22 [0.866]	16 [0.630]	8 [0.315]	11 [0.433]
S-MGT2	48 [1.890]	42 [1.654]	36 [1.417]	3 [0.118]	6 [0.236]
S-MGT3	58 [2.283]	52 [2.047]	46 [1.811]	3 [0.118]	6 [0.236]

S-MGT4•5•6

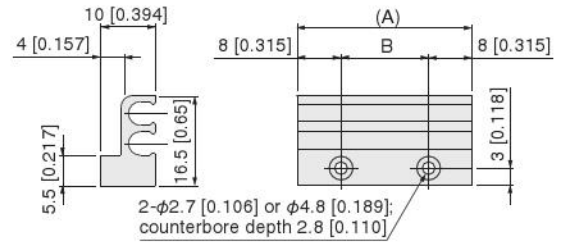

Model	A	B
S-MGT4	49 [1.929]	33 [1.299]
S-MGT5	59 [2.323]	43 [1.693]
S-MGT6	79 [3.110]	63 [2.480]

● Metal stopper

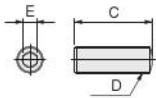

Model	C	D	E
CRK645	20 [0.787]	M4×0.5	2 [0.079]
CRK723	20 [0.787]	M6×0.75	3 [0.118]
CRK724	25 [0.984]	M8×0.75	4 [0.157]
CRK725	30 [1.181]	M10×1	5 [0.197]

● Magnet

M-MGA2

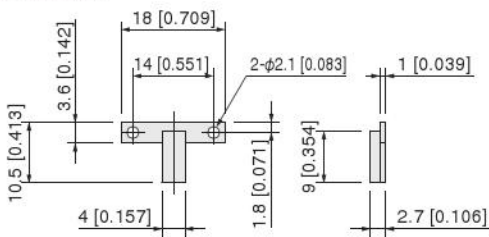

● Locating pin

P-MGA1

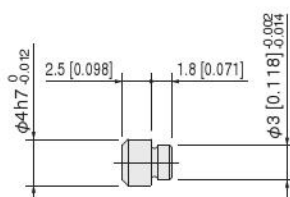

P-MGA2

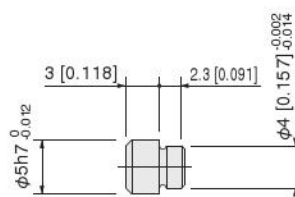

SENSOR SWITCHES



Solid State Type, Reed Switch Type

• Robot cable is standard equipment

Lead wire flexibility is excellent because the conductor used is the same as for robot cables.

Specifications

• Solid State Type

Item \ Model	ZE135□	ZE155□	ZE175□	ZE235□	ZE255□	ZE275□
Wiring type	2-lead wire type	3-lead wire NPN output type	3-lead wire PNP output type	2-lead wire type	3-lead wire NPN output type	3-lead wire PNP output type
Lead wire direction	Horizontal			Vertical		
Power supply voltage	—	4.5 to 28 VDC		—	4.5 to 28 VDC	
Load voltage	10 to 28 VDC		4.5 to 28 VDC		4.5 to 28 VDC	
Load current	2.5 to 20 mA (at 25°C [77°F], and 10 mA at 60°C [140°F])		40 mA max.		2.5 to 20 mA (at 25°C [77°F], and 10 mA at 60°C [140°F])	
Consumption current	—	8 mA max. (24 VDC)	10 mA max. (24 VDC)	—	8 mA max. (24 VDC)	10 mA max. (24 VDC)
Internal voltage drop ^{Note 1}	4 V max.		2 V max. (0.8 V max if load is less than 10 mA)		4 V max.	
Leakage current	0.7 mA max. (24 VDC, 25°C [77°F])		50 μA max. (24 VDC)		0.7 mA max. (24 VDC, 25°C [77°F])	
Response time	1 ms max.					
Insulation resistance	100 MΩ min. (at 500 VDC megger, between case and lead wire terminal)					
Dielectric strength	500 VAC (50/60 Hz) 1 minute (between case and lead wire terminal)					
Shock resistance ^{Note 2}	294.2 m/s ² [30 G] (non-repeated shock)					
Vibration resistance ^{Note 2}	88.3 m/s ² [9 G] (total amplitude of 1.5 mm [0.059 in], 10 to 55 Hz)					
Environmental protection	IP67 (IEC standard), JIS C0920 (water-proof type)					
Operation indicator	When ON: Red LED indicator lights up					
Lead wires	PCCV0.2SQ x 2-lead (brown and blue) x ℓ ^{Note 3}	PCCV0.15SQ x 3-lead (brown, blue, and black) x ℓ ^{Note 3}		PCCV0.2SQ x 2-lead (brown and blue) x ℓ ^{Note 3}	PCCV0.15SQ x 3-lead (brown, blue, and black) x ℓ ^{Note 3}	
Ambient temperature	0 to 60°C [32 to 140°F]					
Storage temperature range	- 10 to 70°C [14 to 158°F]					
Mass	15 g [0.529 oz] (for lead wire length A: 1000 mm [39 in]), 35 g [1.235 oz] (for lead wire length B: 3000 mm [118 in]), 15 g [0.529 oz] (for lead wire length 300 mm [11.8 in] with M8 connector)					

Note 1: The internal voltage drop depends on load current.

2: Measured by Koganei test standard.

3: Lead wire length ℓ : A; 1000 mm [39 in.], B; 3000 mm [118 in.], G; 300 mm [11.8 in.] with M8 connector only for ZE175□ and ZE275□.

※This product is not resistant to lightning surge of the EMC standard (EN61000-6-2 • EN60947-5-2). Prepare protection measures for lightning surge in the system.

• Reed Switch Type

Item \ Model	ZE101□		ZE102□		ZE201□		ZE202□	
Wiring type	2-lead wire type							
Lead wire direction	Horizontal				Vertical			
Load voltage	5 to 28 VDC	85 to 115 VAC (rms)	10 to 28 VDC	85 to 115 VAC (rms)	5 to 28 VDC	85 to 115 VAC (rms)	10 to 28 VDC	85 to 115 VAC (rms)
Load current	40 mA max.	20 mA max.	5 to 40mA	5 to 20 mA	40 mA max.	20 mA max.	5 to 40mA	5 to 20 mA
Internal voltage drop ^{Note 1}	0.1 V max. (at load current 40 mA DC)		3.0 V max.		0.1 V max. (at load current 40 mA DC)		3.0 V max.	
Leakage current	0mA							
Response time	1 ms max.							
Insulation resistance	100 MΩ min. (at 500 VDC megger, between case and lead wire terminal)							
Dielectric strength	1500 VAC (50/60 Hz) 1 minute (between case and lead wire terminal)							
Shock resistance ^{Note 2}	294.2 m/s ² [30 G] (non-repeated shock)							
Vibration resistance ^{Note 2}	88.3 m/s ² [9 G] (total amplitude of 1.5 mm [0.059 in], 10 to 55 Hz), resonance frequency 2570 ±250 Hz							
Environmental protection	IP67 (IEC standard), JIS C0920 (water-proof type)							
Operation indicator	None		When ON: Red LED indicator lights up		None		When ON: Red LED indicator lights up	
Lead wires	PCCV0.2SQ x 2-lead (brown and blue) x ℓ ^{Note 3}							
Ambient temperature	0 to 60°C [32 to 140°F]							
Storage temperature range	- 10 to 70°C [14 to 158°F]							
Contact protection measure	Required (See Contact Protection on page 28)							
Mass	15 g [0.529 oz] (for lead wire length A: 1000 mm [39 in]), 35 g [1.235 oz] (for lead wire length B: 3000 mm [118 in])							

Note 1: The internal voltage drop depends on load current.

2: Measured by Koganei test standard.

3: Lead wire length ℓ : A; 1000 mm [39 in.], B; 3000mm [118 in.]

SENSOR SWITCHES

Two-color LED Solid State Type

● Robot cable is standard equipment

Lead wire flexibility is excellent because the conductor used is the same as for robot cables.

Specifications

● Two-color LED Solid State Type

Item \ Model	ZE137□	ZE157□	ZE177□	ZE237□	ZE257□	ZE277□
Wiring type	2-lead wire type	3-lead wire NPN output type	3-lead wire PNP output type	2-lead wire type	3-lead wire NPN output type	3-lead wire PNP output type
Lead wire direction	Horizontal			Vertical		
Power supply voltage	—	4.5 to 28 VDC		—	4.5 to 28 VDC	
Load voltage	10 to 28 VDC		4.5 to 28 VDC		4.5 to 28 VDC	
Load current	2.5 to 20 mA (at 25°C [77°F], and 10 mA at 60°C [140°F])		40 mA max.		2.5 to 20 mA (at 25°C [77°F], and 10 mA at 60°C [140°F])	
Consumption current	—	8 mA max. (24 VDC)	10 mA max. (24 VDC)	—	8 mA max. (24 VDC)	10 mA max. (24 VDC)
Internal voltage drop ^{Note 1}	4 V max.		2 V max. (0.8 V max. if load is less than 10 mA)		4 V max.	
Leakage current	0.7 mA max. (24 VDC, 25°C [77°F])		50 μA max. (24 VDC)		0.7 mA max. (24 VDC, 25°C [77°F])	
Response time	1 ms max.					
Insulation resistance	100 M Ω min. (at 500 VDC megger, between case and lead wire terminal)					
Dielectric strength	500 VAC (50/60 Hz) 1 minute (between case and lead wire terminal)					
Shock resistance ^{Note 2}	294.2 m/s ² [30 G] (non-repeated shock)					
Vibration resistance ^{Note 2}	88.3 m/s ² [9 G] (total amplitude of 1.5 mm [0.059 in], 10 to 55 Hz)					
Environmental protection	IP67 (IEC standard), JIS C0920 (water-proof type)					
Operation indicator	Appropriate operation range: Green LED indicator lit when on, operation range: Red LED indicator lit when on					
Lead wires	PCCV0.2SQ x 2-lead (brown and blue) x ℓ ^{Note 3}	PCCV0.15SQ x 3-lead (brown, blue, and black) x ℓ ^{Note 3}		PCCV0.2SQ x 2-lead (brown and blue) x ℓ ^{Note 3}	PCCV0.15SQ x 3-lead (brown, blue, and black) x ℓ ^{Note 3}	
Ambient temperature	0 to 60°C [32 to 140°F]					
Storage temperature range	- 10 to 70°C [14 to 158°F]					
Mass	15 g [0.529 oz] (for lead wire length A: 1000 mm [39 in]), 35 g [1.235 oz] (for lead wire length B: 3000 mm [118 in]), 15 g [0.529 oz] (for lead wire length 300 mm [11.8 in] with M8 connector)					

Note 1: The internal voltage drop depends on load current.

2: Measured by Koganei test standard.

3: Lead wire length ℓ : A; 1000 mm [39 in.], B; 3000 mm [118 in.], G; 300 mm [11.8 in.] with M8 connector only for ZE177□ and ZE277□ .

Operation

● Explanation of operation of two-color LED solid state type

ZE137□, ZE157□, ZE177□, ZE237□, ZE257□, ZE277□

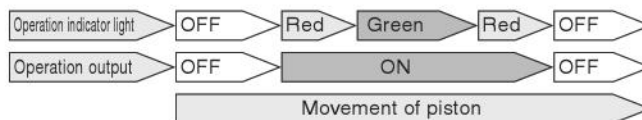

Note: The operating output may become unstable due to the effects of the operating and installation environments, even if the appropriate operating range (green LED indicator lit) is fixed.

Diagram of Inner Circuits

● Solid State Type

● ZE135□, ZE235□

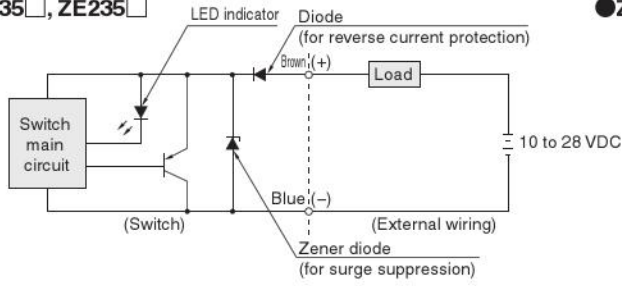

● ZE155□, ZE255□

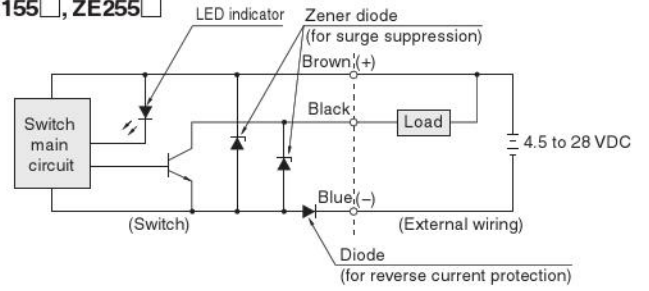

● ZE175□, ZE275□

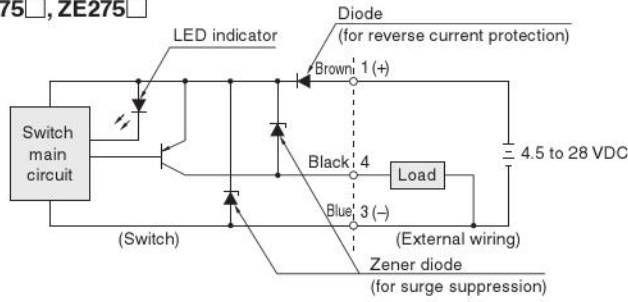

● Two-color LED Solid State Type

● ZE137□, ZE237□

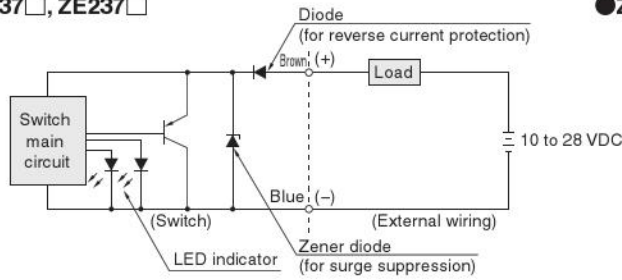

● ZE157□, ZE257□

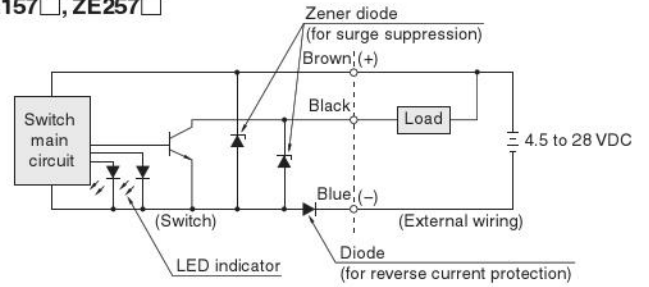

● ZE177□, ZE277□

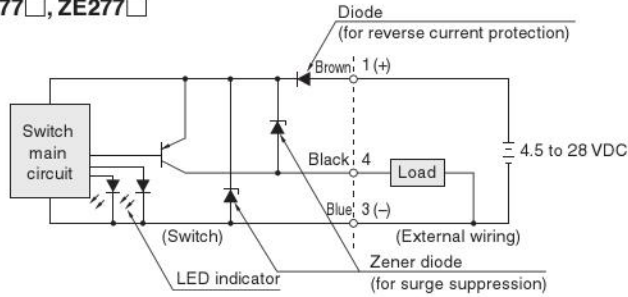

● Reed Switch Type

● ZE101□, ZE201□

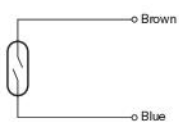

● ZE102□, ZE202□

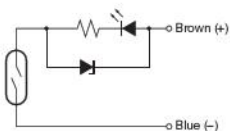

● Horizontal Lead Wire

● Solid state type (ZE135□, ZE155□, ZE175□, ZE137□, ZE157□, and ZE177□)

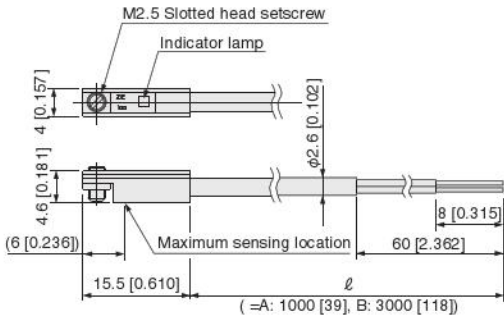

● Reed switch type (ZE101□, ZE102□)

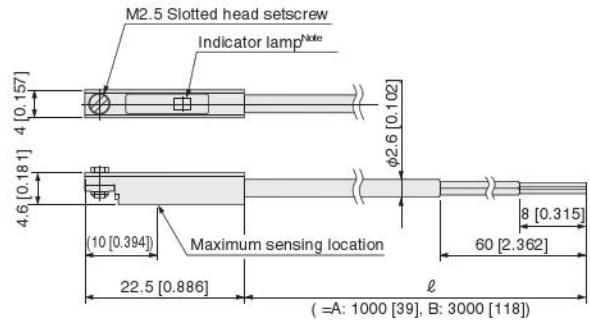

● Solid state type (ZE175G, ZE177G)

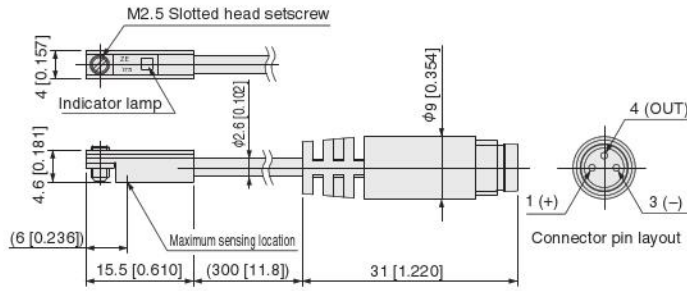

Note: Not available with the ZE101 □.

● Vertical lead wire

● Solid state type (ZE235□, ZE255□, ZE275□, ZE237□, ZE257□, ZE277□)

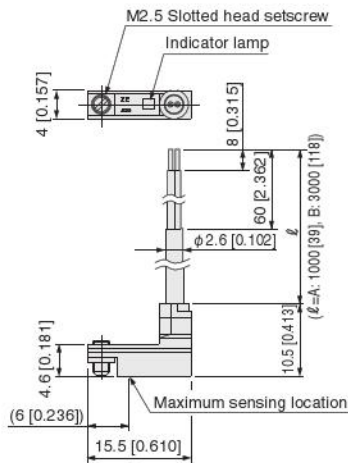

● Reed switch type (ZE201□, ZE202□)

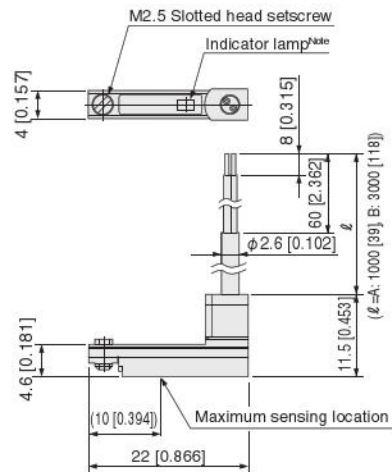

● Solid state type (ZE275G, ZE277G)

Note: Not available with the ZE201 □.

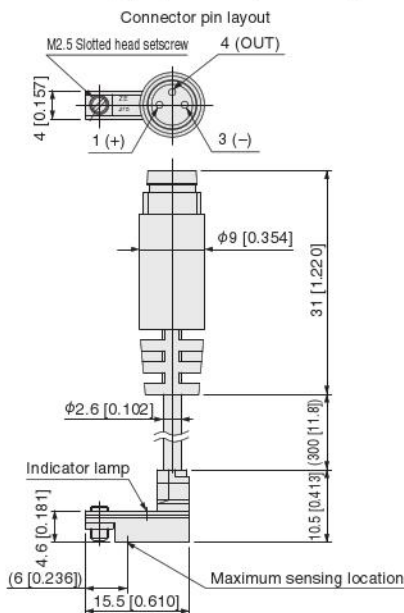

Contact Protection for Reed Switch Type Sensor Switches

In order to use the reed switch type sensor switches in a stable condition, take the following contact protection measures.

- When connecting inductive load (electromagnetic relay, etc.).
- When capacity surge is generated. (When lead wire length exceeds 10 m [3.28 ft.])

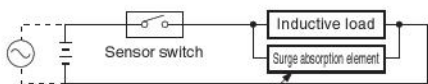

For DC: Diode or CR, etc.
 For AC: CR etc.
 Diode: Forward current should be more than the circuit current. Reverse direction voltage should be inverse voltage that is 10 times or more of the circuit voltage.

C: 0.01 to 0.1μF
 R: 1 to 4kΩ

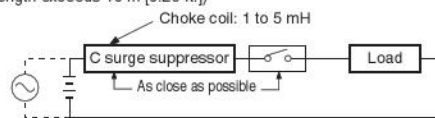

Points of Wiring Solid State Type Sensor Switches

● 2-lead wire

● Basic connection

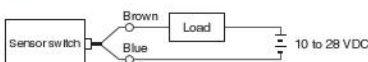

● Connection with relays

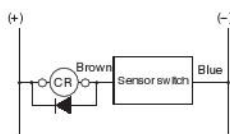

AND (series) connection and OR (parallel) connection

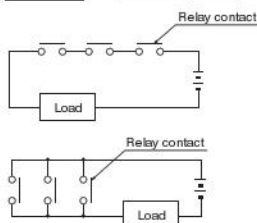
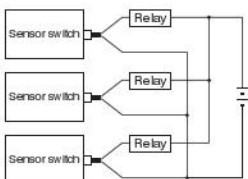

● Connection with solenoid valve

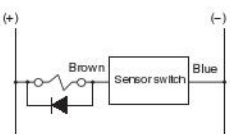

● Connection with programmable controller

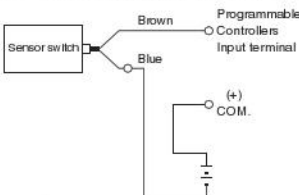

● 3-lead wire with NPN output

● Basic connection

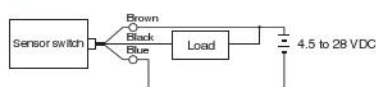

● Connection with relays

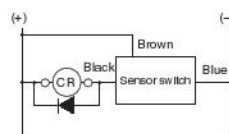

AND (series) connection and OR (parallel) connection

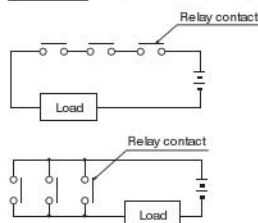
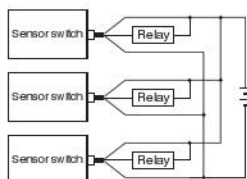

● Connection with solenoid valve

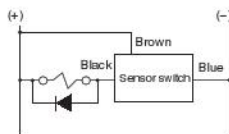

● Connection with programmable controller

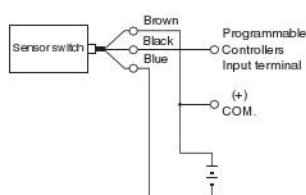

● 3-lead wire with PNP output

● Basic connection

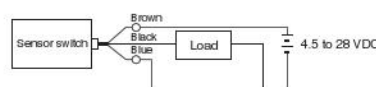

● Connection with relays

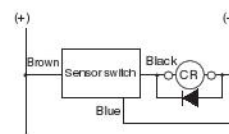

AND (series) connection and OR (parallel) connection

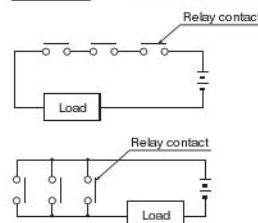
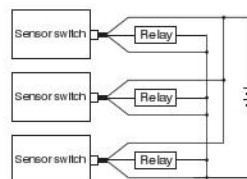

● Connection with solenoid valve

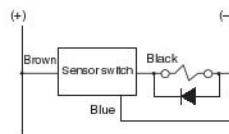

● Connection with programmable controller

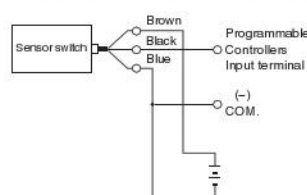

1. Connect wires according to the color of the lead wires. If the connection is incorrect, it could cause damage to the sensor switch due to the absence of overcurrent protection.
2. A surge suppression protection diode is recommended for the inductive load such as electromagnetic relays, etc.
3. Avoid series (AND) connection because the voltage of the circuit will drop in proportion to the number of sensor switches.
4. When using parallel (OR) connection, the same sensor output lines (e.g. the same black lead wires) can be connected together, but the current leakage will increase by the number of sensor switches. Therefore, be aware of load return abnormalities.

5. Because the sensor switches are a magnetically sensitive type, avoid using them in locations subject to strong external magnetic fields or bringing them too close to power lines or to where other large electric currents are present. In addition, do not use magnetic material for the mounting bracket, because it will cause erratic operations.
6. Do not pull or bend the lead wires excessively.
7. Avoid using sensor switches in strong chemical or gas environments.
8. Consult us for use in ambient atmospheres subject to water or oil.

Moving Sensor Switch

- Loosening the mounting screw allows the sensor switch to be moved along the switch mounting groove of the Mini Guide Tables.
- Tighten the mounting screw with a tightening torque of 0.1 N·m [0.885 in·lbf] to 0.2 N·m [1.770 in·lbf].

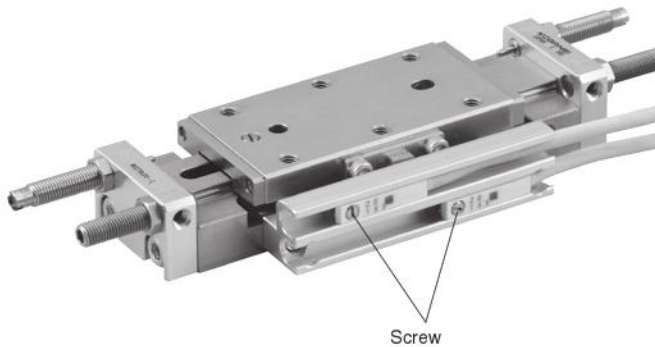

When Mounting the Cylinders with Sensor Switches in Close Proximity

When mounting Mini Guide Tables in close proximity, install them at the values shown in the table below, or larger.

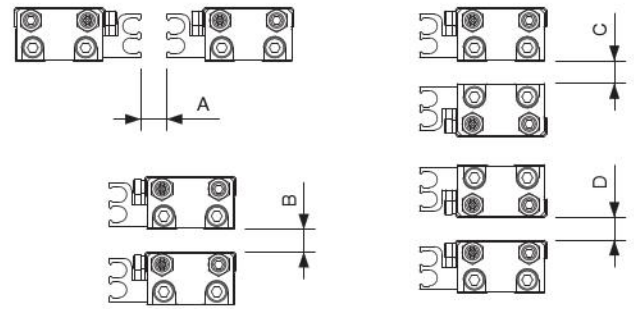

● Solid State Type mm [in]

Model	A	B	C	D
MGTS6	3 [0.118]	2 [0.079]	4 [0.157]	4 [0.157]
MGTS8	3 [0.118]	2 [0.079]	4 [0.157]	4 [0.157]
MGTS10	3 [0.118]	2 [0.079]	4 [0.157]	4 [0.157]
MGTS12	3 [0.118]	2 [0.079]	2 [0.079]	4 [0.157]
MGTS16	3 [0.118]	2 [0.079]	2 [0.079]	2 [0.079]
MGTS20	3 [0.118]	2 [0.079]	2 [0.079]	2 [0.079]

● Reed Switch Type mm [in]

Model	A	B	C	D
MGTS6	2 [0.079]	2 [0.079]	4 [0.157]	2 [0.079]
MGTS8	2 [0.079]	2 [0.079]	4 [0.157]	2 [0.079]
MGTS10	2 [0.079]	2 [0.079]	4 [0.157]	2 [0.079]
MGTS12	2 [0.079]	2 [0.079]	2 [0.079]	2 [0.079]
MGTS16	2 [0.079]	2 [0.079]	2 [0.079]	2 [0.079]
MGTS20	2 [0.079]	2 [0.079]	2 [0.079]	2 [0.079]

● Two-color LED Solid State Type mm [in]

Model	A	B	C	D
MGTS6	6 [0.236]	6 [0.236]	4 [0.157]	4 [0.157]
MGTS8	6 [0.236]	6 [0.236]	4 [0.157]	4 [0.157]
MGTS10	6 [0.236]	6 [0.236]	4 [0.157]	4 [0.157]
MGTS12	8 [0.315]	2 [0.079]	2 [0.079]	4 [0.157]
MGTS16	8 [0.315]	2 [0.079]	2 [0.079]	2 [0.079]
MGTS20	8 [0.315]	2 [0.079]	2 [0.079]	2 [0.079]

Sensor Switch Operating Range, Response Differential, and Maximum Sensing Locations

● Operating range: ℓ

The distance the piston travels in one direction, while the switch is in the ON position.

● Response differential: C

The distance between the point where the piston turns the switch ON and the point where the switch is turned OFF as the piston travels in the opposite direction.

● Solid state type, two-color LED Solid State Type mm [in]

Item	Model	MGTS6	MGTS8	MGTS10	MGTS12	MGTS16	MGTS20
Operating range: ℓ		1.5 to 3.2 [0.059 to 0.126]					
Response differential: C		0.2 [0.008] or less					
Maximum sensing location ^{note}		6 [0.236]					

Remark: The above table shows reference values.

Note: This is the length measured from the switch's opposite end side to the lead wire.

● Reed Switch Type mm [in]

Item	Model	MGTS6	MGTS8	MGTS10	MGTS12	MGTS16	MGTS20
Operating range: ℓ		3.0 to 6.0 [0.118 to 0.236]					
Response differential: C		1.5 [0.059] or less					
Maximum sensing location ^{note}		10 [0.394]					

Remark: The above table shows reference values.

Note: This is the length measured from the switch's opposite end side to the lead wire.

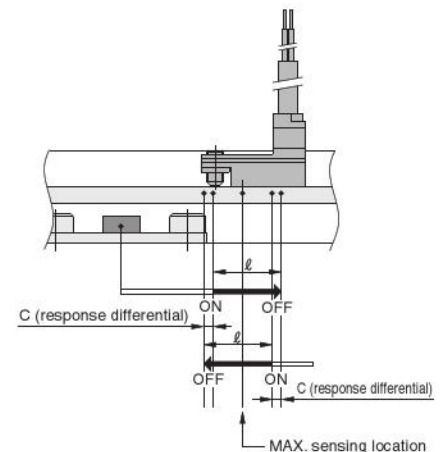

Mounting Position of the End of Stroke Detection Sensor Switches

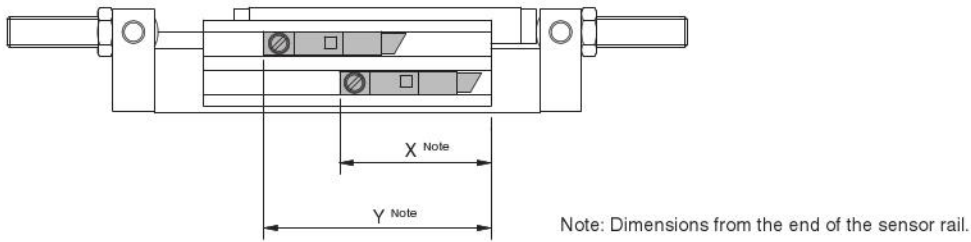

● Solid State Type, Two-color LED Solid State Type

mm [in]

Model	MGTS6		MGTS8		MGTS10			MGTS12			MGTS16			MGTS20		
Stroke	10 [0.394]	20 [0.787]	10 [0.394]	20 [0.787]	10 [0.394]	20 [0.787]	30 [1.181]	20 [0.787]	30 [1.181]	50 [1.969]	20 [0.787]	30 [1.181]	50 [1.969]	20 [0.787]	30 [1.181]	50 [1.969]
X	20 [0.787]	20 [0.787]	20 [0.787]	20 [0.787]	20 [0.787]	20 [0.787]	20 [0.787]	20.5 [0.807]	20.5 [0.807]	20.5 [0.807]	20.5 [0.807]	20.5 [0.807]	20.5 [0.807]	20.5 [0.807]	20.5 [0.807]	20.5 [0.807]
Y	30 [1.181]	40 [1.575]	30 [1.181]	40 [1.575]	30 [1.181]	40 [1.575]	50 [1.969]	40.5 [1.594]	50.5 [1.988]	70.5 [2.776]	40.5 [1.594]	50.5 [1.988]	70.5 [2.776]	40.5 [1.594]	50.5 [1.988]	70.5 [2.776]

● Reed Switch Type

mm [in]

Model	MGTS6		MGTS8		MGTS10			MGTS12			MGTS16			MGTS20		
Stroke	10 [0.394]	20 [0.787]	10 [0.394]	20 [0.787]	10 [0.394]	20 [0.787]	30 [1.181]	20 [0.787]	30 [1.181]	50 [1.969]	20 [0.787]	30 [1.181]	50 [1.969]	20 [0.787]	30 [1.181]	50 [1.969]
X	24 [0.945]	24 [0.945]	24 [0.945]	24 [0.945]	24 [0.945]	24 [0.945]	24 [0.945]	24.5 [0.965]	24.5 [0.965]	24.5 [0.965]	24.5 [0.965]	24.5 [0.965]	24.5 [0.965]	24.5 [0.965]	24.5 [0.965]	24.5 [0.965]
Y	34 [1.339]	44 [1.732]	34 [1.339]	44 [1.732]	34 [1.339]	44 [1.732]	54 [2.126]	44.5 [1.752]	54.5 [2.146]	74.5 [2.933]	44.5 [1.752]	54.5 [2.146]	74.5 [2.933]	44.5 [1.752]	54.5 [2.146]	74.5 [2.933]

Linear magnetic sensor controller

ZL1



- Senses the linear position of the cylinder within the specified range.
- Exchange with control devices is possible due to standard equipment for analog output (1 to 5 VDC).
- Switch output is possible in four places. Simple position detection is possible.

Specifications

● Controller

Item	Model	ZL1
Power supply voltage		24 VDC \pm 10%
Consumption current		50 mA max. (Not including supply power to sensor)
Sensor input supply power and voltage		5 VDC
Sensor input maximum input voltage		3.0V
Switch output method		NPN open collector output, 5 points
Load voltage		30 VDC
Load current		50 mA max.
Switch output volume repeatability		\pm 1% F.S. \pm 1 digit ^{Note}
Internal voltage drop		0.3 V max. (When I _c = 5 mA)
Response time		5 ms max.
Operation indicator light		Lights red when each switch output is on
Value display		% display within effective measuring range (4 digits, 2-color display: red and green)
Analog output voltage range		1 to 5 VDC (1 K Ω output impedance)
Analog output repeatability		\pm 1% of F.S. (25°C [77°F] \pm 5°C [41°F]) ^{Note}
Insulation resistance		100 M Ω min. (at 500 VDC megger, between case and lead wire terminal)
Withstand voltage		500 VAC (50/60 Hz) 1 minute (between case and lead wire terminal)
Shock resistance		294.2 m/s ² [30 G] (non-repeated shock)
Ambient temperature		0 to 50°C [32 to 122°F] (non-condensation, non-freezing)
Storage temperature range		-10 to 70°C [14 to 158°F] (non-condensation, non-freezing)
Mass		40 g [1.411 oz]

Note: This performance excludes the mechanical looseness of a cylinder with a fixed magnet (standalone performance). In the case of a movable type cylinder whose magnet is not fixed, the movable part and repeatability are degraded.

● Sensor head

Item	Model	ZLS1-□L	ZLS2-□L
Power supply voltage		5 VDC \pm 5%	
Consumption current		20 mA max.	
Mounting methods		Horizontal lead wire embedded type	Vertical lead wire embedded type
Operation indicator light		Red LED lights at optimal sensitivity position (operation position can be changed by settings)	
Lead wires		Heat-resistant, oil-resistant vinyl sheath instrumentation cable ϕ 2.9 [0.114] 0.15 mm ² [0.0002 in ²] 5-lead With 6 P connectors	
Insulation resistance		100 M Ω min. (at 500 VDC megger, between case and lead wire terminal)	
Withstand voltage		500 VAC (50/60 Hz) 1 minute (between case and lead wire terminal)	
Shock resistance		294.2 m/s ² [30 G] (non-repetitive)	
Environmental protection		IP67	
Vibration resistance		88.3 m/s ² [9 G] (Double amplitude: 1.5 mm [0.059 in], 10 to 55 Hz)	
Ambient temperature		0 to 50°C [32 to 122°F] (non-condensation, non-freezing)	
Storage temperature range		-10 to 70°C [14 to 158°F] (non-condensation, non-freezing)	
Mass		20 g [0.705 oz] (when 1 L lead wire length is 1000 mm [39 in])	

Actuation Range when Installed on Mini Guide Table

Name	Model	Bore size					
		6 [0.236]	8 [0.315]	10 [0.394]	12 [0.472]	16 [0.630]	20 [0.787]
Mini guide table ^{Note}	MGTS	2 [0.079]	2 [0.079]	2 [0.079]	2 [0.079]	2 [0.079]	2 [0.079]

mm [in]

Note: A sensor cylinder with a sensor switch magnet built in is used as the actuator.

Remark: The values above include response differentials and are for reference purposes.

Connector number

● Sensor head

Connector side number	Signal name	Lead wire color
1	Sensor head voltage (+)	Sensor head brown lead
2	Sensor head voltage output A_IN	Sensor head white lead
3	Sensor head voltage output B_IN	Sensor head black lead
4	Indicator (LED) input	Sensor head red lead
5	GND	Sensor head blue lead
6	NC	Not connected

● Power supply

Pin No.	Signal name	Lead wire color
1	Power supply voltage input (24 V)	Brown
2	Analog output (1 to 5 V)	Gray
3	Effective measuring range signal output (STAB)	Black
4	GND	Blue
5	Switch output OUT1	White
6	Switch output OUT2	Red
7	Switch output OUT3	Green
8	Switch output OUT4	Yellow

Handling Instructions and Precautions



Mounting and Piping

Sensor head and connector connection overview

The ZLS1-□ sensor head is provided to you with the mini plug wire mount plug connected to the sensor head unit. A special tool is required if you need to reconnect in order to adjust the length. Use the following procedure when reconnecting.

1. Be sure to use the mount plug and the special tool shown below when reconnecting.
6 P mini clamp wire mount plug model: ZL-6M
Special tool Model: 1729940-1
Tyco Electronics Japan G.K.
2. Check to make sure that the connector cover (lead wire inlet) is sitting above the body of the connector. Note that a connector whose cover is even with the body of the connector cannot be used.

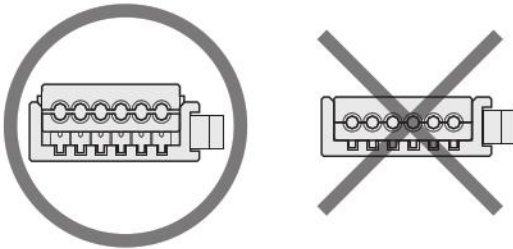

3. Cut the sensor head cable to the required length. Strip the outer covering of the cable, 50 mm [1.969 in] from the end, to expose the lead wires. Do not strip the insulation from the individual lead wires at this time.

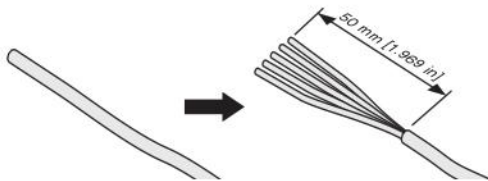

4. Insert the lead wires into the connector cover holes in accordance with the information in the table below. Check to make sure the lead wires are fully inserted (wire goes in about 9 mm [0.354 in]) as far as they will go by viewing the semi-transparent top cover of the connector. Note that supplying power while connections are incorrect will damage the sensor head and controller.

Connector side number	Signal name	Lead wire color
1	Sensor head voltage (+)	Sensor head brown lead
2	Sensor head voltage output A_IN	Sensor head white lead
3	Sensor head voltage output B_IN	Sensor head black lead
4	Indicator (LED) input	Sensor head red lead
5	GND	Sensor head blue lead
6	NC	Not connected

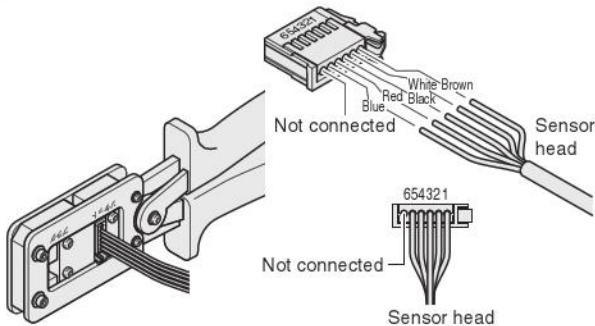

5. Taking care not to allow the lead wires to come out of the connector, use the special tool (don't try to use any other tool) to squeeze the cover and body of the connector until the cover is pressed into the body. Connection is complete when the cover is even with the connector body.
6. Double check to make sure that wiring is correct.

Attaching and detaching of the sensor head and power supply/switching cables

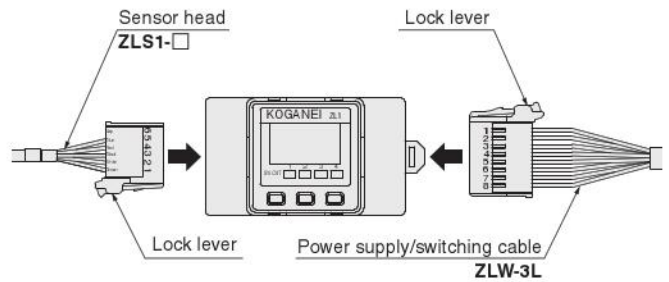

To attach the sensor head and the power supply/switching cables, position the lock levers as shown in the illustration above, and then insert until they lock into place with the controller side connectors. To disconnect, press the lock lever down as far as it will go as you pull the connector to unplug it. At this time, take care not to apply undue force to the lead wires.

Attaching the protective front cover

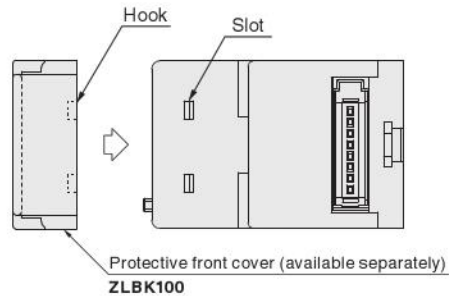

Attach the protective front cover so the hooks inside the cover enter the slots on the linear magnetic sensor controller.

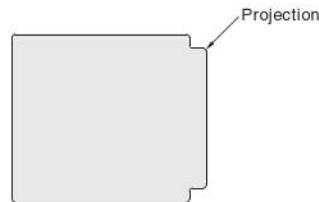

*To remove the protective front cover, hook your finger on the projection on one side of the cover and remove it.

Sensor head installation precautions

1. When mounting actuators fitted with linear magnetic sensors in close proximity to each other, secure a clearance of at least 40 mm [1.575 in] apart. $A \geq 40 \text{ mm [1.575 in]}$

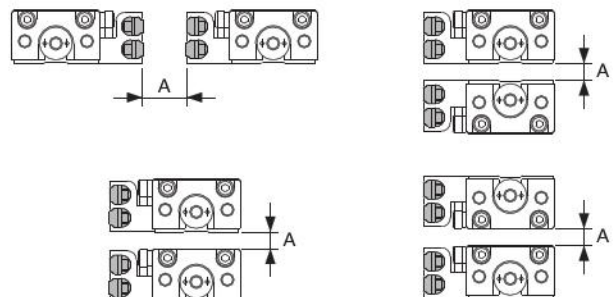

2. Refer to "Moving Sensor Switch" on page 30 for instructions on installing and moving linear magnetic sensor heads.

Handling Instructions and Precautions



General Precautions

Wiring

1. Always connect the frame ground (F.G.) terminal when using a switching regulator available in the general market as the power supply.
2. Always connect the frame ground (F.G.) terminal when using devices that generate electrical noise, such as switching regulators and inverter motors, in the vicinity of the sensor mount position.
3. After completing the wiring, check that all wires are connected correctly.

Other

1. Check the power fluctuation to ensure that the input power does not exceed the rated value.
2. Avoid using the product while the power is unstable when powering up (for 1 second).
3. Do not operate the keys using a needle or any other sharp instrument.

Internal Circuit Diagrams

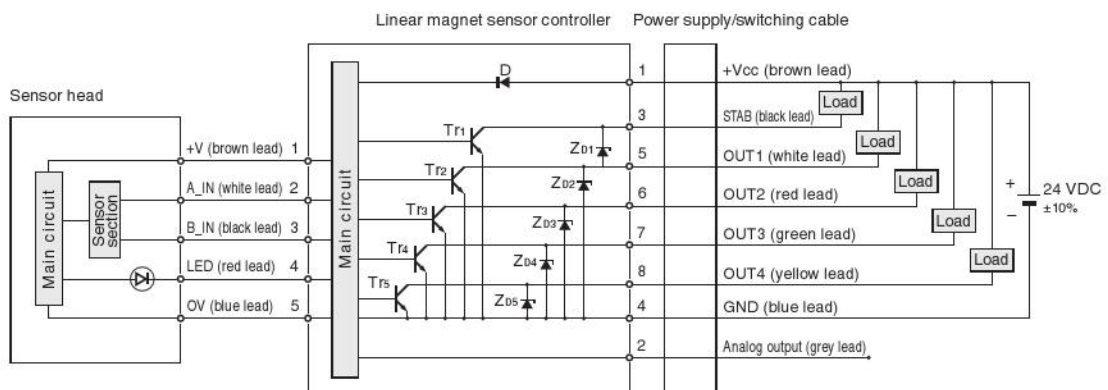

Note: Note that extending the cable can cause a drop in voltage due to cable resistance.

Symbol D	: Power supply reverse-polarity protection diode
Z _{D1} to Z _{D5}	: Surge voltage absorption zener diode
T _{r1} to T _{r5}	: NPN output transistors

Linear Magnetic Sensor Controller Order Codes

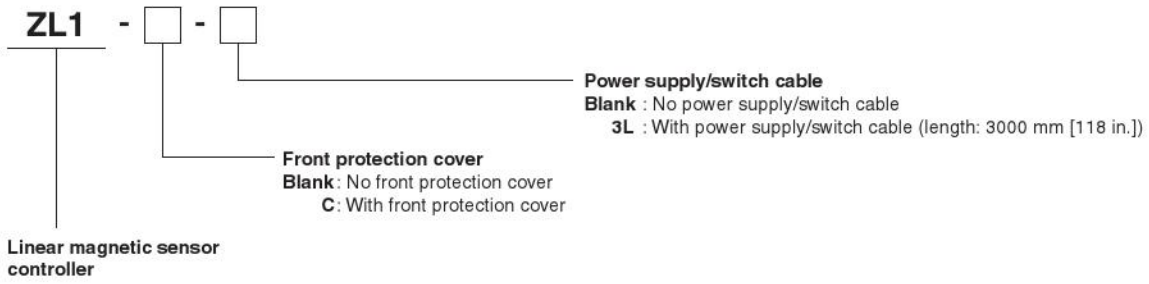

Additional Parts (Separately Available Parts)

● Sensor head, horizontal

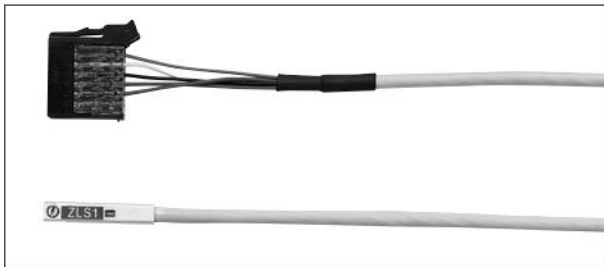
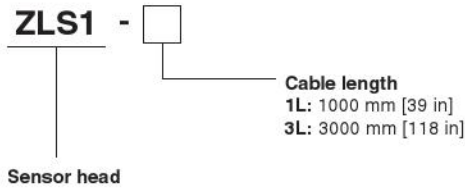

● Sensor head, vertical

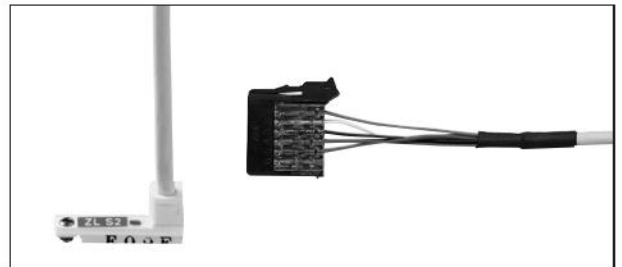
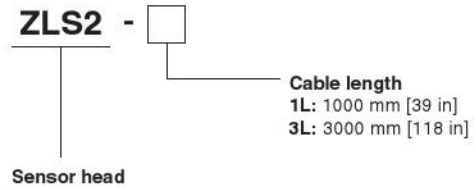

● Power supply/switch cable

ZLW-3L



● Front protection cover

ZLBK100



● 6-pin mini-clamp wire mount plug (for sensor head)

ZL-6M



● 8-pin mini-clamp wire mount plug (for power supply/switch cable)

ZL-8M



Dimensions of the Linear Magnetic Sensor Controller mm [in]

● ZL1-□-□(Controller portion)

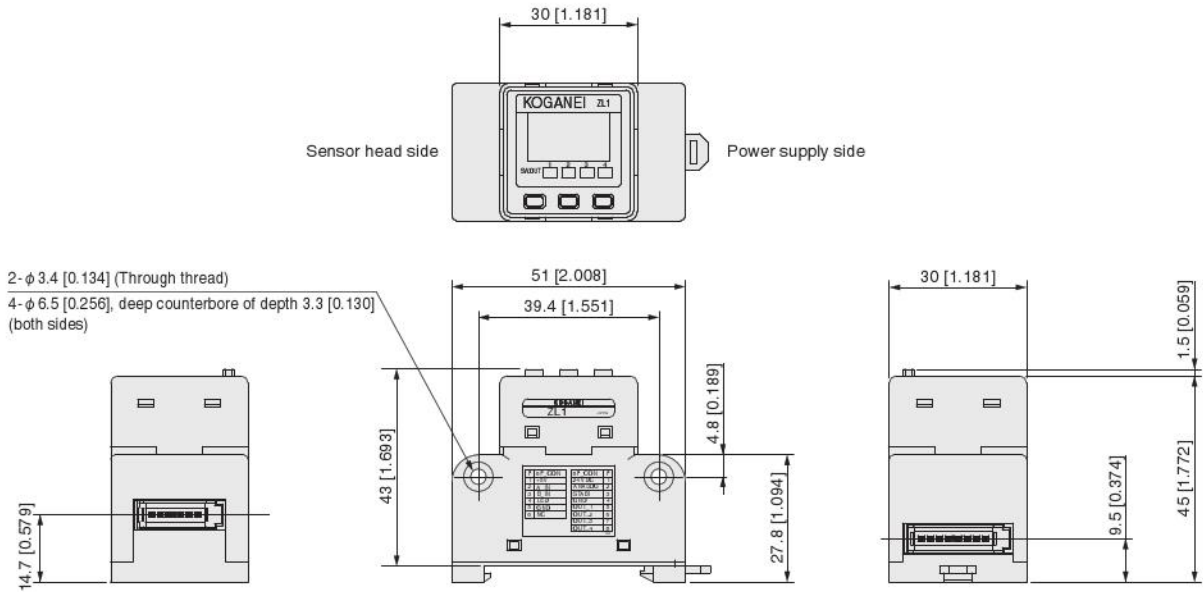

● ZLS1-□(Sensor head portion)

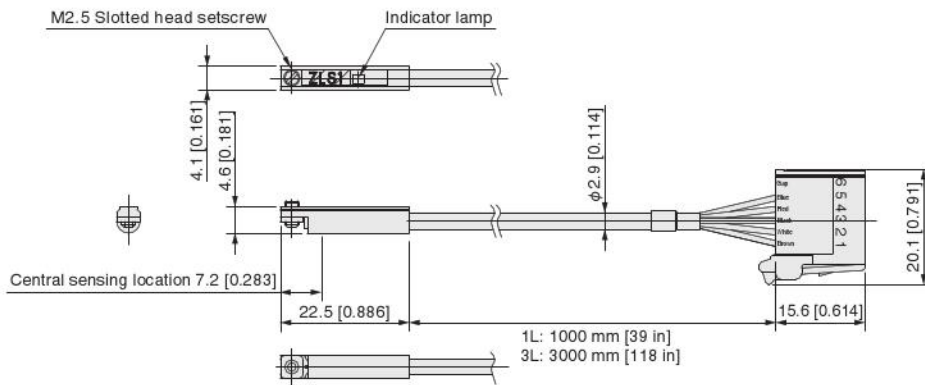

● ZLS2-□(Sensor head portion)

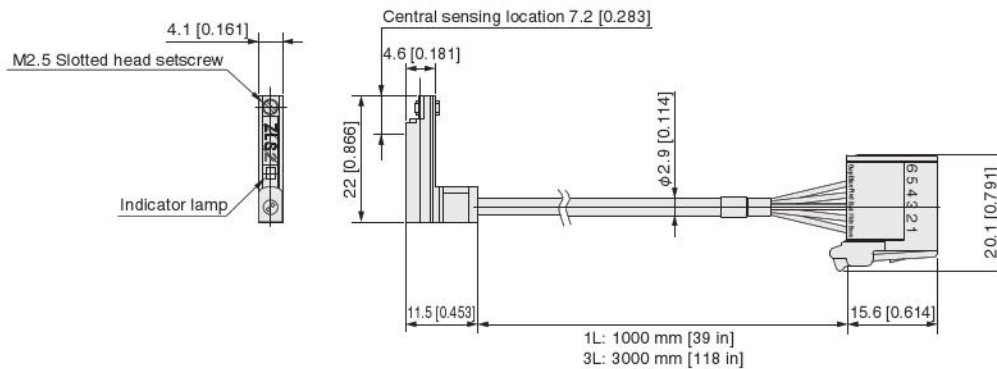

● ZLW-3L(Power supply/switch cable)

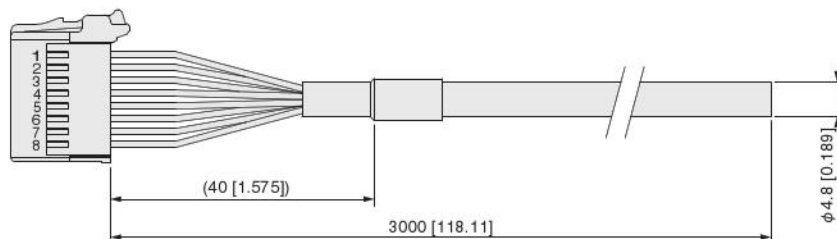

● ZLBK100 (Front protection cover)

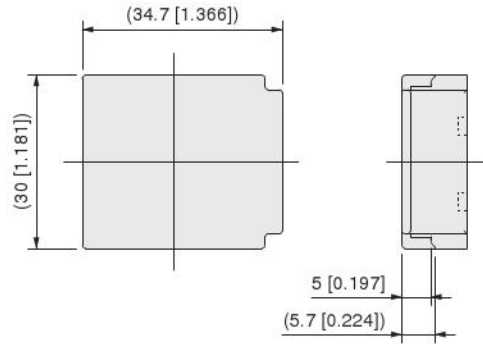

● ZL-6M (6-pin mini-clamp wire mount plug for sensor head)

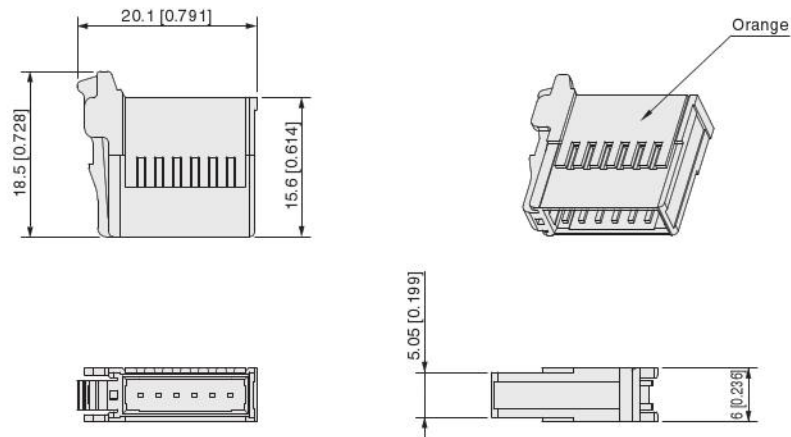

● ZL-8M (8-pin mini-clamp wire mount plug for power supply/switch cable)

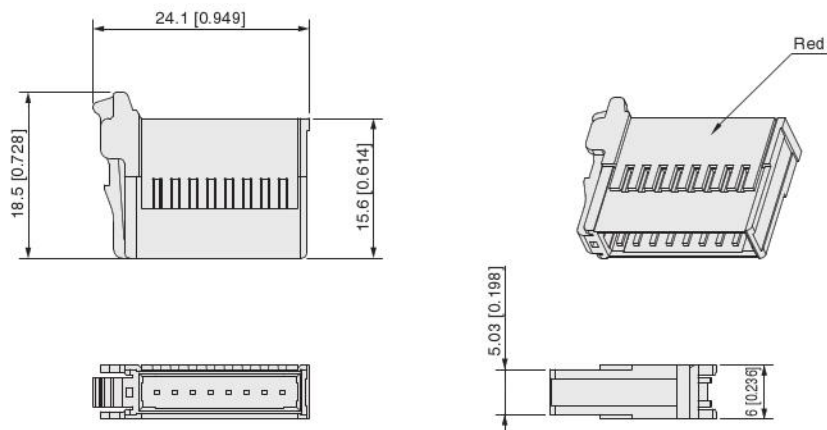

See the catalog (PDF) for linear magnet sensor controllers on Koganei's homepage for detailed "Setup guidelines" for linear magnet sensor controllers. <Search example: search for "linear magnet" or "ZL1"> Additionally, the SET2 number for mini guide tables (MGTS) for installed cylinder model setting (SET2) is "20".

Guide to recommended related products!

For details, see our homepage. <http://www.koganei.co.jp>

Compact High-Precision Actuators

Mini Guide Slider

High precision installation **Compact** design

Running parallelism **0.005 mm** NOTE
[0.0002 in]

Installation parallelism **0.03 mm** NOTE
[0.001 in]

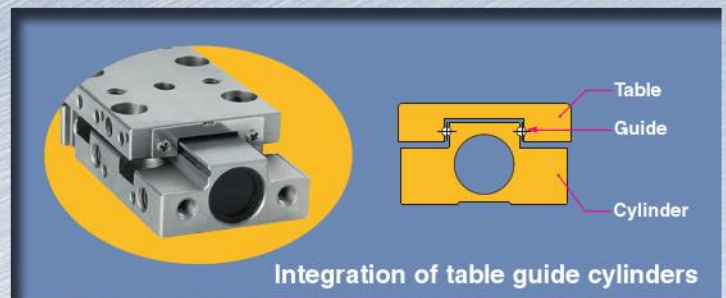

Note: With some variations.

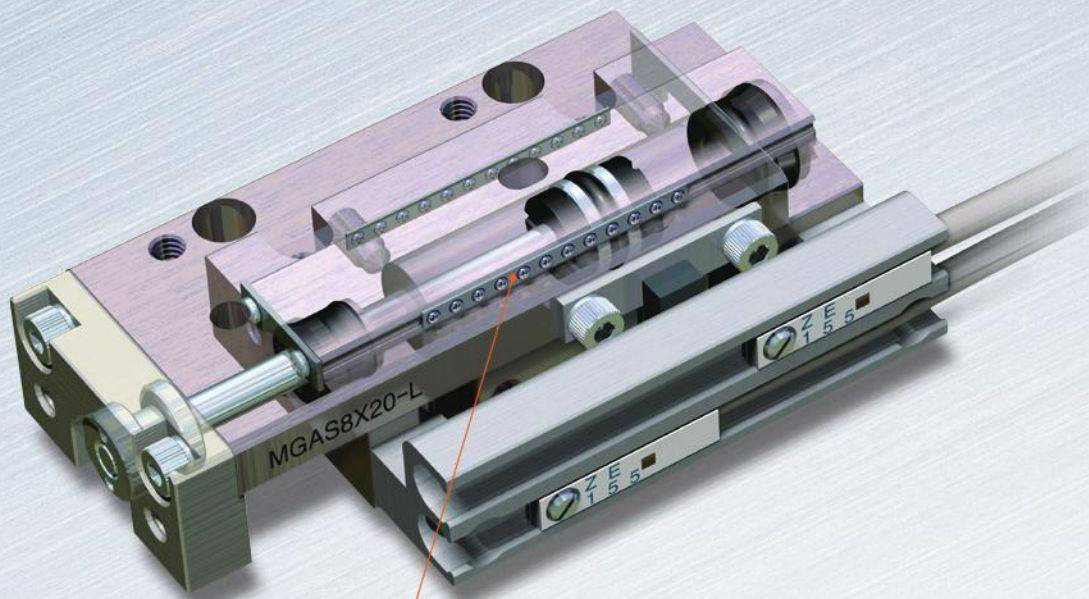

4-point contact linear guide

- 4-point contact type can handle variable or complex loads.
- Retainer installed finite track type.
- Pre-load reduces clearance and play.

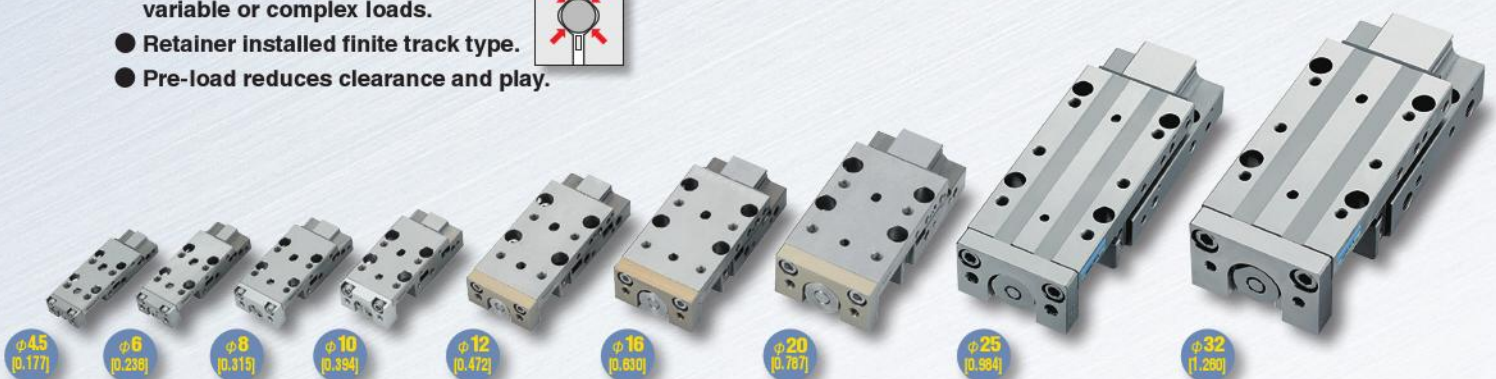
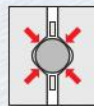

Limited Warranty

KOGANEI CORP. warrants its products to be free from defects in material and workmanship subject to the following provisions.

Warranty Period The warranty period is 180 days from the date of delivery.

Koganei Responsibility If a defect in material or workmanship is found during the warranty period, KOGANEI CORP. will replace any part proved defective under normal use free of charge and will provide the service necessary to replace such a part.

Limitations

- This warranty is in lieu of all other warranties, expressed or implied, and is limited to the original cost of the product and shall not include any transportation fee, the cost of installation or any liability for direct, indirect or consequential damage or delay resulting from the defects.

- KOGANEI CORP. shall in no way be liable or responsible for injuries or damage to persons or property arising out of the use or operation of the manufacturer's product.

- This warranty shall be void if the engineered safety devices are removed, made inoperative or not periodically checked for proper functioning.

- Any operation beyond the rated capacity, any improper use or application, or any improper installation of the product, or any substitution upon it with parts not furnished or approved by KOGANEI CORP., shall void this warranty.

- This warranty covers only such items supplied by KOGANEI CORP. The products of other manufacturers are covered only by such warranties made by those original manufacturers, even though such items may have been included as the components.

The specifications are subject to change without notice.

URL <http://www.koganei.co.jp>

E-mail: overseas@koganei.co.jp



KOGANEI CORPORATION

OVERSEAS DEPARTMENT

3-11-28, Midori-cho, Koganei City, Tokyo 184-8533, Japan
Tel: 81-42-383-7271 Fax: 81-42-383-7276

KOGANEI INTERNATIONAL AMERICA, INC.

39300 Civic Center Dr., Suite 280, Fremont, CA 94538, U.S.A.
Tel: 1-510-744-1626 Fax: 1-510-744-1676

SHANGHAI KOGANEI INTERNATIONAL TRADING CORPORATION

Room 2606-2607, Tongda Venture Building No.1, Lane 600, Tianshan Road,
Shanghai, 200051, China
Tel: 86-21-6145-7313 Fax: 86-21-6145-7323

TAIWAN KOGANEI TRADING CO., LTD.

Rm. 2, 13F, No88, Sec. 2, Zhongxiao E. Rd., Zhongzheng Dist., Taipei City 100,
Taiwan (ROC)
Tel: 886-2-2393-2717 Fax: 886-2-2393-2719

KOGANEI KOREA CO., LTD.

6F-601, Tower Bldg., 1005, Yeongde0-dong, Giheung-gu, Yongin-si, Gyeonggi-do,
446-908, Korea
Tel: 82-31-246-0414 Fax: 82-31-246-0415

KOGANEI (THAILAND) CO., LTD.

3300/90, Tower B, Elephant Tower, 16th Fl., Phaholyothin Road, Chomphon,
Chatuchak, Bangkok 10900, Thailand
Tel: 66-2-937-4250 Fax: 66-2-937-4254

KOGANEI ASIA PTE. LTD.

69 Ubi Road 1, #05-18 Oxley Bizhub, Singapore 408731
Tel: 65-6293-4512 Fax: 65-6293-4513