

MULTISTAGE MICRO EJECTORS

MED07-E, MED10-E



Specifications

Item		Basic model	MED07-E□	MED10-E□
Media			Air ^{Note 2}	
Operating pressure range		MPa [psi.]	0.2~0.6 [29~87]	
Proof pressure		MPa [psi.]	1.03 [149]	
Operating temperature range (atmosphere and media)		°C [°F]	5~50 [41~122]	
Nozzle diameter		mm [in.]	0.7 [0.028]	1.0 [0.039]
Vacuum ^{Note 1}		kPa [in.Hg]	-84 [-24.8]	
Vacuum flow rate ^{Note 1}		ℓ /min [ft. ³ /min.] (ANR)	25 [0.88]	50 [1.77]
Compressed air consumption ^{Note 1}		ℓ /min [ft. ³ /min.] (ANR)	23 [0.81]	46 [1.62]
Lubrication			Prohibited	
Filtration		μm	30	
Port size	Vacuum generation port		Rc1/4	
	Compressed air supply port		Rc1/8 (Rc1/4) ^{Note 3}	
Mounting direction			Any	
Main valve specifications	Operation type		Indirect operating	
	Number of positions, number of ports		2 positions, 2 ports	
	Valve function		Normally closed (NC standard) or normally open (NO optional)	
	Effective area	mm ² [Cv]	4.5 [0.25]	
	Shock resistance	m/s ² [G]	1372.9 [140] (Axial direction 588.4 [60])	
Manual override			Non-locking type	

- Notes: 1. Value (approximate) is measured at an air pressure of 0.5MPa [73psi].
 2. Assumes use of pure air from which oil mist and dust, etc., have been removed.
 3. Figure in parentheses () shows manifold port.

Solenoid Specifications

Rated voltage		DC 5V	DC 6V	DC 12V	DC 24V
Type					
With built-in flywheel diode for surge suppression					
Operating voltage range		4.5~5.5 (5±10%)	5.4~6.6 (6±10%)	10.8~13.2 (12±10%)	21.6~26.4 (24±10%)
Current (When rated voltage is applied)		325 (1.6W) (335 (1.7W) with LED indicator)	270 (1.6W) (280 (1.7W) with LED indicator)	130 (1.6W) (140 (1.7W) with LED indicator)	70 (1.6W) (80 (1.7W) with LED indicator)
Maximum allowable leakage current		30	25	15	5
Insulation resistance		100 or more			
Wiring and lead wire length	Standard	Grommet type: 300mm [11.8in.]			
	Optional	Plug connector type: 300mm [11.8in.]			
Color of lead wire		Green (+) Black (-)	Blue (+) Black (-)	Brown (+) Black (-)	Red (+) Black (-)
Color of LED indicator		Red			
Surge suppression (as standard)		Flywheel diode			

Electronic Vacuum Switch Specifications

Item		Model	PS310
Media			Air or non-corrosive gas
Operating temperature range		°C [°F]	-10~60 [14~140] (No freezing)
Operating humidity range		%RH	35~95
Operating pressure range		kPa [in.Hg]	-101.3~0 [-29.92~0]
Proof pressure		MPa [psi.]	0.2 [29]
Pressure setting range		kPa [in.Hg]	-101.3~-10.1 [-29.92~-2.98]
Hysteresis ^{Note}		%	2~9
Repeatability			Within ±3%FS (0~50°C [32~122°F])
Electrical specifications	Operating type		NPN open collector output, NO type (Output ON when falls below set pressure)
	Operating voltage range	DCV	12~24 ±10% (ripple Vp-p 10% or less)
	Switching capacity		DC30V, 100mA or less (Internal voltage drop: 1V or less at load current 100mA, 0.4V or less at load current 16mA.)
	Consumption current	mA MAX.	20
	Insulation resistance	MΩ	100 or more (DC500V megger, between charging part and case)
Surge suppression			Zener diode (As standard)
Mechanical characteristics	Shock resistance	m/s ² [G]	490.3 [50]
	Vibration resistance		10~55Hz (total amplitude 1.5mm [0.06in.]) or 98.1m/s ² [10G] (2 hours Max. at each XYZ-axis)
Operation indicator			When ON, LED indicator lights up.
Lead wire			Vinyl cabtyre: 0.14SQX3-leadX500mm (Overall length)
Mounting direction			Any
Materials (body cover)			Plastic

Note: Value is at a set pressure of -86.7kPa [-25.6in.Hg].

Port Size

Basic model	Port size	
	Vacuum generation port	Compressed air supply port
Micro ejector	MED07-E1, MED07-E2 MED10-E1, MED10-E2	Rc1/4 Rc1/8 (When assembled as a manifold: Rc1/4)
	-02 Port exhaust (option)	Rc1/4
Manifold	MEDM□A Location of piping connection	Rc1/4 Ejector Rc1/4 Manifold

Ejector with Solenoid Valve Order Codes

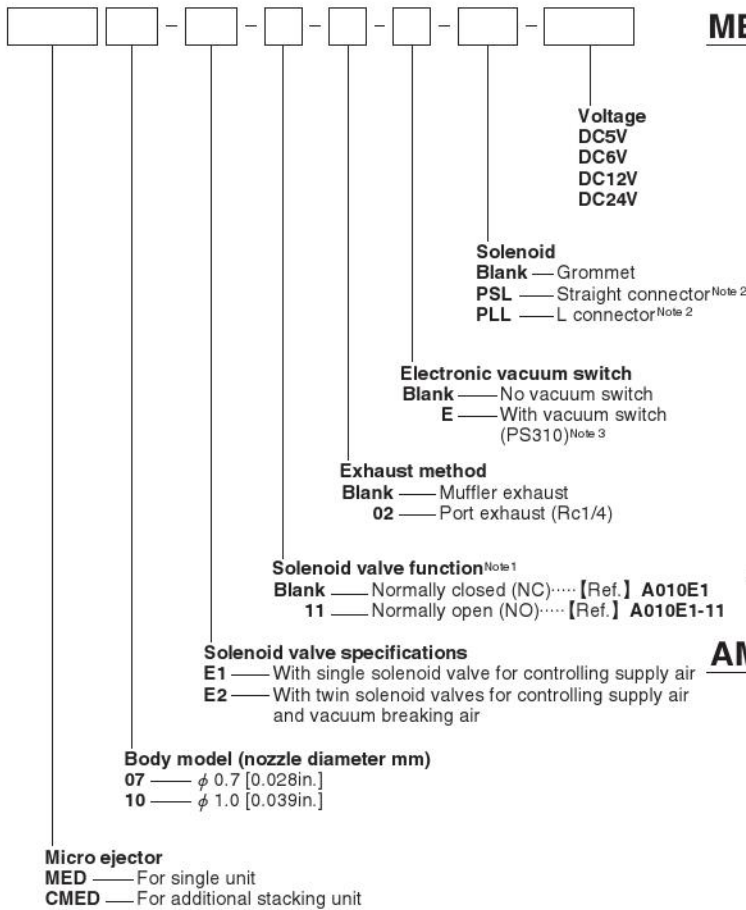

- Notes: 1. Only for the -11 (normally open) solenoid valve for controlling supply air. The solenoid valve for controlling vacuum breaking air in the E2 type solenoid valve specifications is normally closed only.
2. Lead wires in the 1L: 1000mm [39in.], 3L: 3000mm [118in.] length are available as made to order for plug connector type.
3. Lead wires in the 2000mm [79in.] length are available as made to order for the electronic vacuum switch.

Electronic Vacuum Switch Order Codes

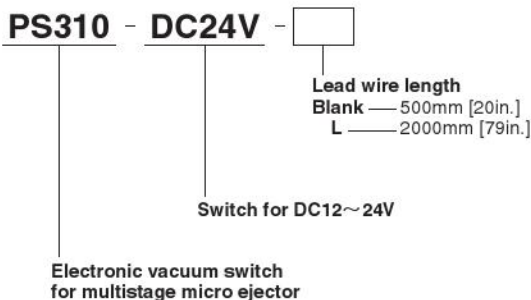

Manifold Order Codes

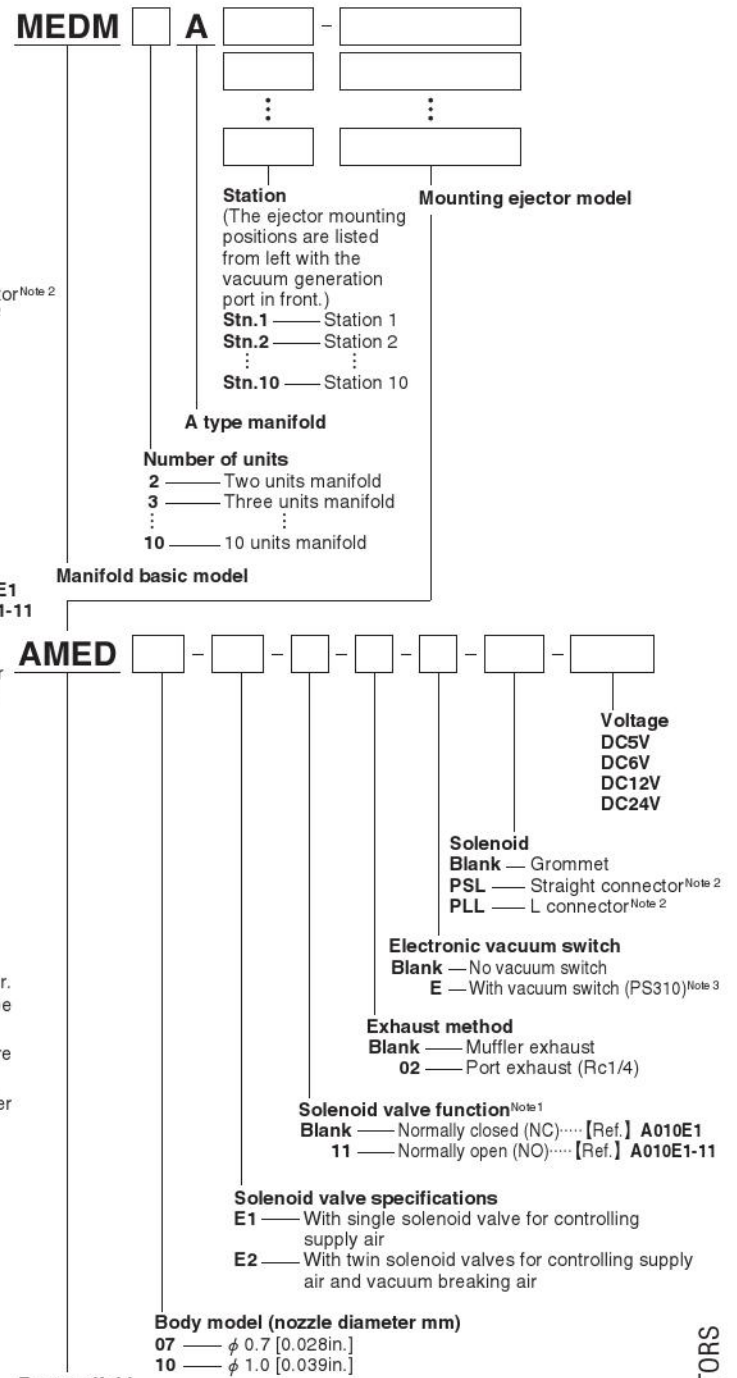

Additional Stacking Unit Order Codes (for adding one unit when using on manifolds)

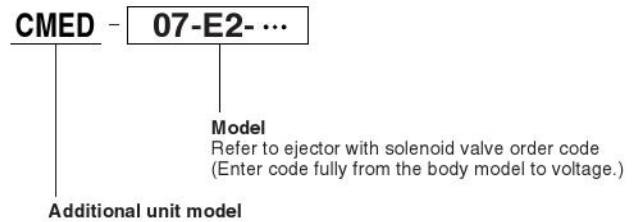

In addition to one manifold use ejector (AMED...), the additional stacking unit includes two connecting rods, one gasket, and one O-ring.

Replacement Filter Order Code (element only)

MED-F

Operation Principle and Major Parts

● De-energized

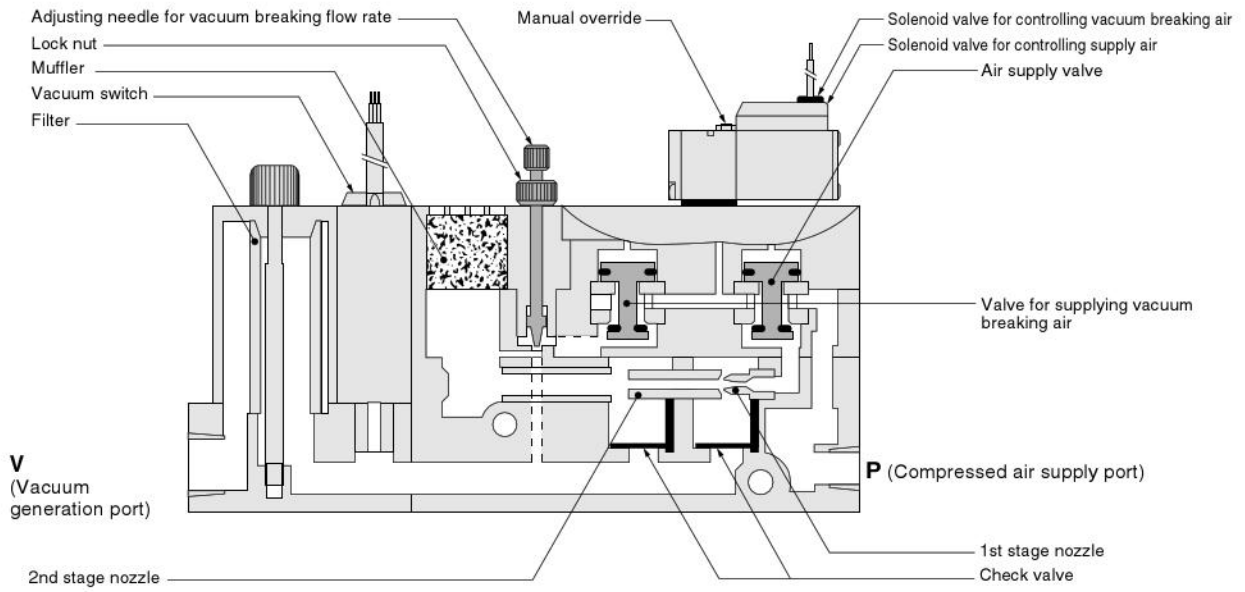

● When energizing a solenoid valve for controlling supply air (generating vacuum)

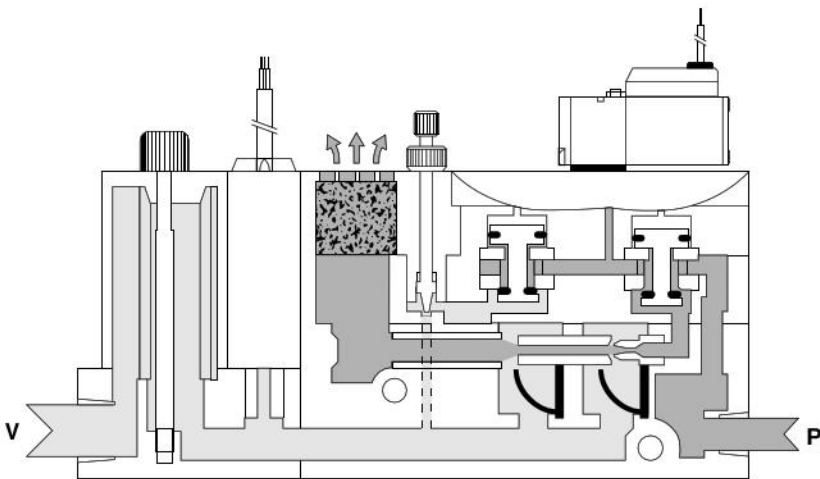

● When energizing solenoid valve for controlling vacuum breaking air

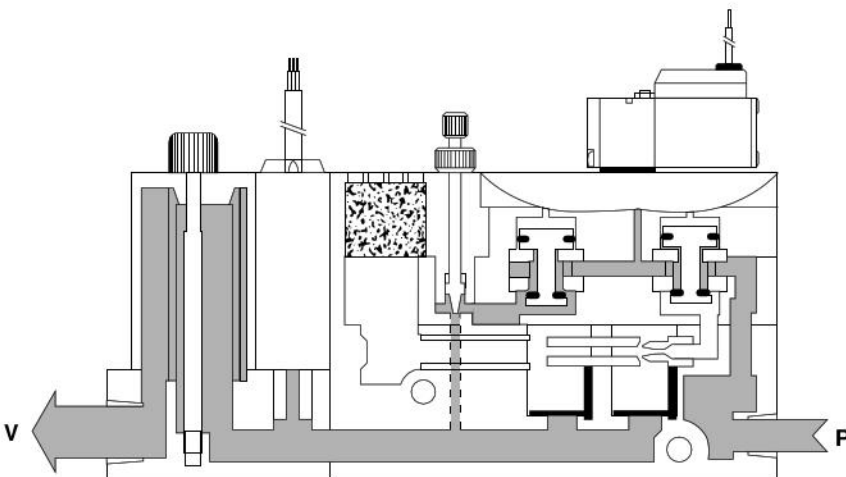

Major Parts and Materials

	Parts	Materials
Micro ejector	Body	Aluminum alloy (painted) and plastic
	Nozzle	Brass
	Diffuser	Plastic
	O-ring	Synthetic rubber (NBR)
	Gasket	
Manifold	End plate	Aluminum alloy (painted)

Symbols

With single solenoid valve

●MED07-E1 ●MED10-E1

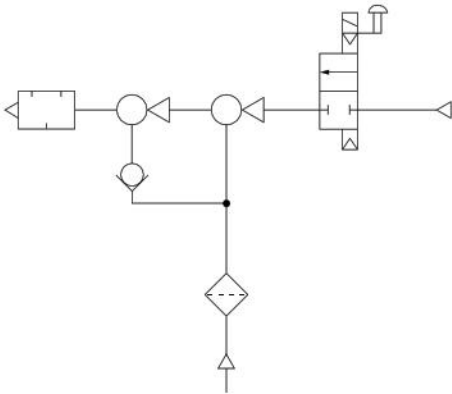

With single solenoid valve and vacuum switch

●MED07-E1-E ●MED10-E1-E

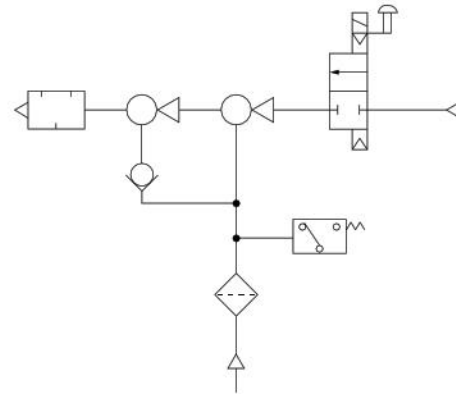

With twin solenoid valves

●MED07-E2 ●MED10-E2

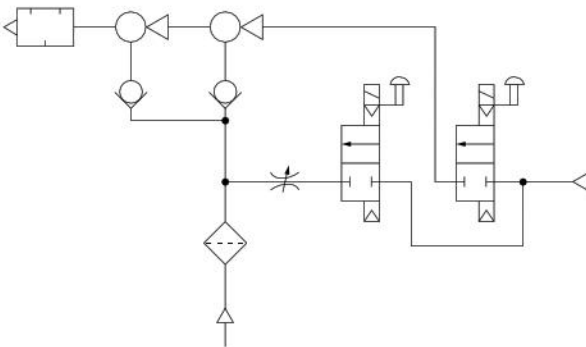

With twin solenoid valves and vacuum switch

●MED07-E2-E ●MED10-E2-E

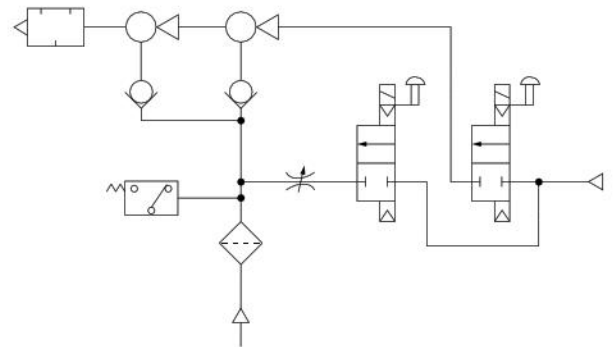

Mass

●Multistage micro ejector

g [oz.]

Item	Basic model	MED07/MED10
With single solenoid valve	MED□□-E1	295 [10.41]
With twin solenoid valves	MED□□-E2	325 [11.46]
Additional mass	Port exhaust -02	14 [0.49]

Calculation example: MED07-E2-02 Mass: $325 + 14 = 339\text{g}$ [11.96oz.]
 Mass of port exhaust
 MED07-E2 mass

●Electronic vacuum switch

PS310 (only body).....15g [0.53oz.]

●Manifolds

g [oz.]

Item	Model	MED07/MED10	
		AMED□□-E1	AMED□□-E2
Mass of manifold body by number of units	1 unit	250 [8.8]	280 [9.9]
	2 units	500 [17.6]	560 [19.8]
	3 units	750 [26.5]	840 [29.6]
	4 units	1000 [35.3]	1120 [39.5]
	5 units	1250 [44.1]	1400 [49.4]
Additional mass	Manifold, end plate	140 [4.94]	
	With electronic vacuum switch -E	15 [0.53]	

Calculation example: MEDM5A Stn.1 AMED07-E1
 Stn.2 AMED10-E1
 Stn.3~5 AMED10-E2-E
 Mass of Stn.5: $250 + 250 + 3 \times (280 + 15) + 140 = 1525\text{g}$ [53.79oz.]
 AMED10-E2-E mass Manifold end plate mass
 Mass of AMED07-E1 or AMED10-E1

Dimensions (mm)

MED07-E2
MED10-E2

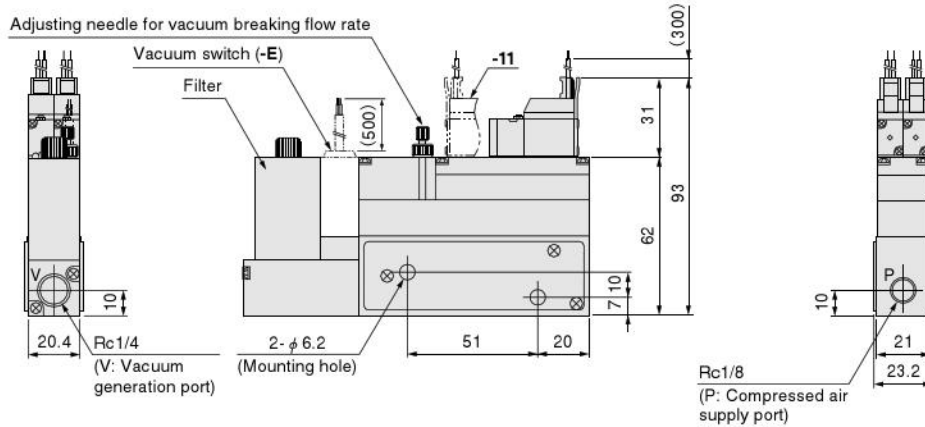
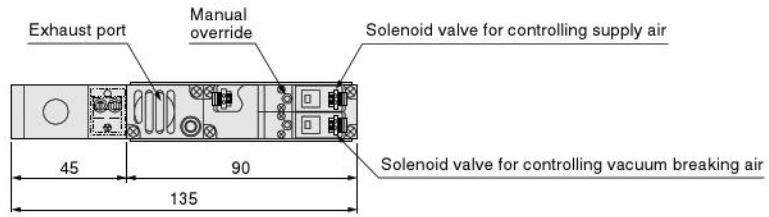

MEDM□A

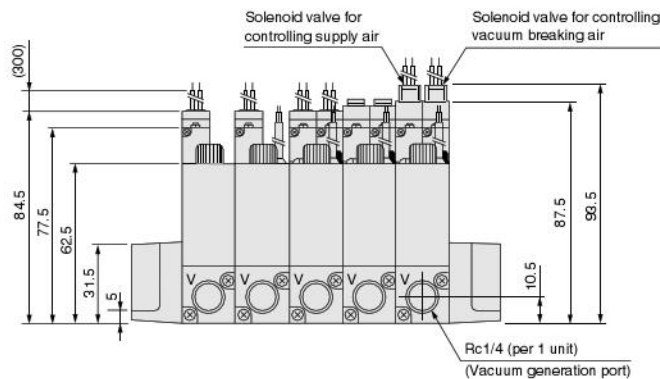
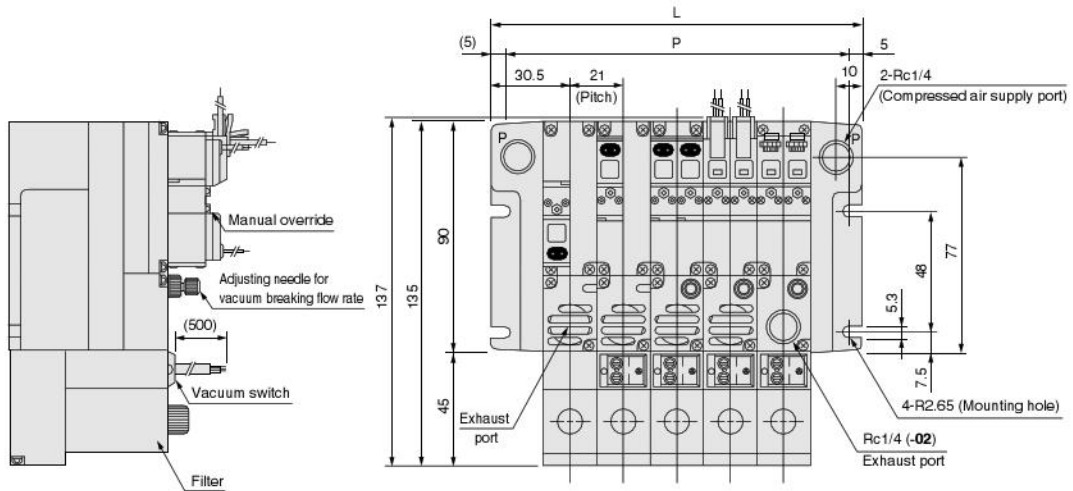

Unit dimensions

Number of units	L	P
2	82	72
3	103	93
4	124	114
5	145	135
6	166	156
7	187	177
8	208	198
9	229	219
10	250	240

Dimensions of Electronic Vacuum Switch (mm)

PS310

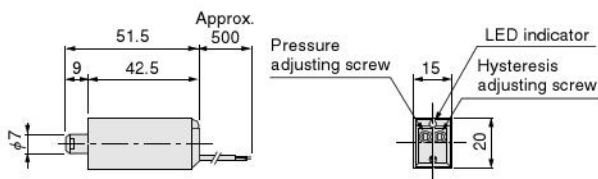

Air Consumption, Vacuum and Vacuum Flow Rate

MED07

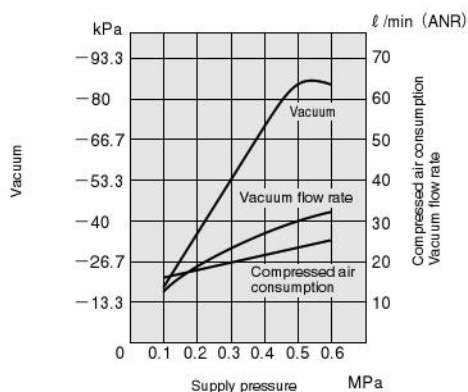

MED10

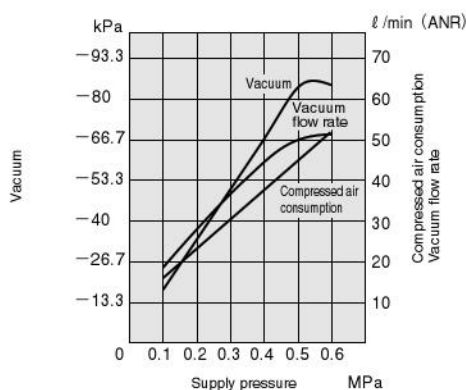

1MPa = 145psi. 1kPa = 0.145psi. -100kPa = -29.54in.Hg 1l/min. = 0.0353ft³/min.

Time to Reach Vacuum and Vacuum Breaking Time

Measurement method

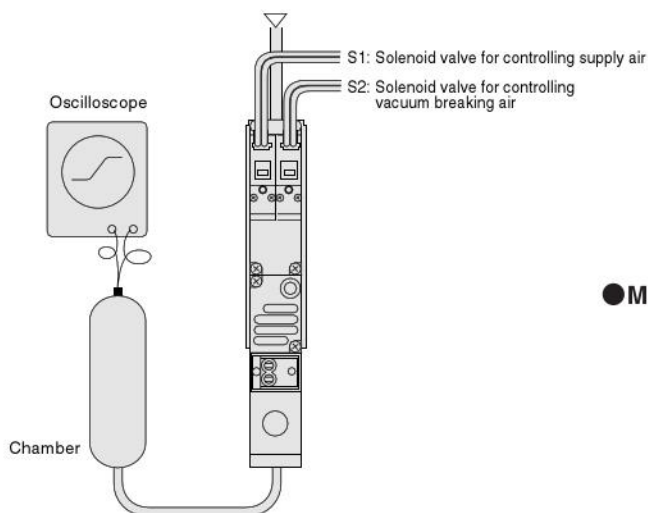

MED□-E1

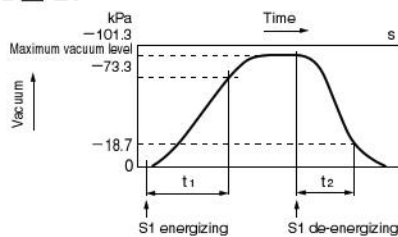

Air pressure: 0.5MPa [73psi.]
Adjusting needle for vacuum breaking flow: Fully open
t₁: Time to reach -73.3kPa [-21.65in.Hg] in the chamber after energizing S1.
t₂: In MED□-E1, time to reach -18.7kPa [-5.52in.Hg] in the chamber after de-energizing S1.

MED□-E2

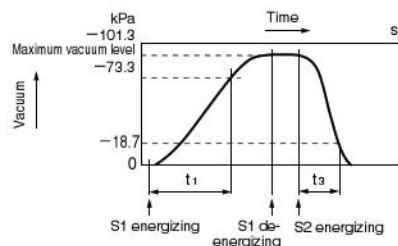

t₃: In MED□-E2, time to reach -18.7kPa [-5.52in.Hg] in the chamber after energizing S2 and when vacuum was at its maximum level.

Response time

Model	Time	5 [0.305]			10 [0.610]			20 [1.22]			50 [3.05]			100 [6.10]			200 [12.2]			500 [30.5]			1000 [61.0]		
		t ₁	t ₂	t ₃	t ₁	t ₂	t ₃	t ₁	t ₂	t ₃	t ₁	t ₂	t ₃	t ₁	t ₂	t ₃	t ₁	t ₂	t ₃	t ₁	t ₂	t ₃	t ₁	t ₂	t ₃
MED07		0.2	0.1	0.1	0.3	0.1	0.1	0.3	0.1	0.1	0.5	0.2	0.1	0.8	0.3	0.1	1.5	0.5	0.1	3.4	0.9	0.2	6.8	1.7	0.3
MED10		0.2	0.1	0.1	0.2	0.1	0.1	0.2	0.1	0.1	0.3	0.1	0.1	0.5	0.2	0.1	0.9	0.3	0.1	2.1	0.5	0.2	4.1	0.9	0.3

Note: Some degree of variation may occur due to piping size and chamber shape. The figures can be viewed as a guide.



Multistage micro ejector

Device configuration

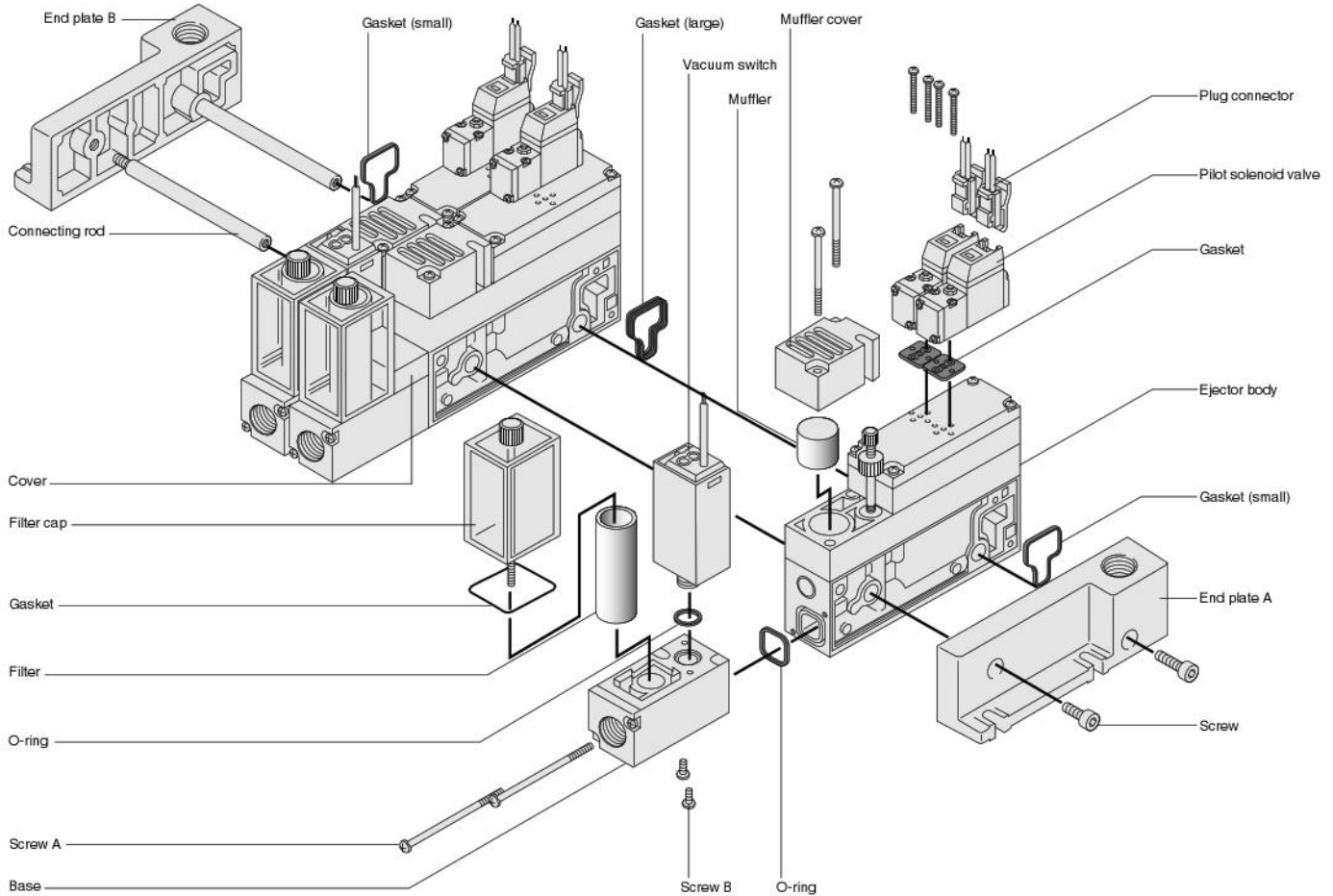

Manifold assembly

Screw two connecting rods all the way into end plate B. Then, assemble ejector bodies into connecting rods in any order. Finally, place in end plate A, and tighten hexagon socket screws to secure it in place.

Be sure to place both end plates on a flat surface when tightening rods and screws. For the gaskets, use the gasket (large) between the ejector bodies, and the gasket (small) on each side with the both end plates.

Additional stacking method (CMED)

Remove two hexagon socket screws, and remove end plate A. Screw two supplied stacking rods into the connecting rods. At this time, check to see whether the connecting rods from end plate B are secured. Insert the gaskets into the locations prescribed in the illustration above, and assemble the ejector body and end plates.

Caution: Since the ejector bodies in this MED series function as manifolds, they have no block plate. For adding units, assemble the additional stacking unit (CMED) according to the illustration above. Note that linked units cannot be reduced. Consult us in the case. (A special connecting rod is required.)

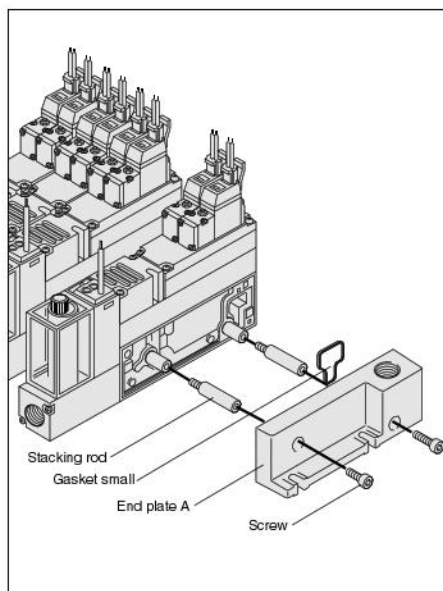

Electronic Vacuum Switch

Mounting

If mounting a vacuum switch onto an existing unit, the currently mounted cover must be removed.

- First, remove the two screws A. At this time, the base will separate from the ejector body.
- Then remove the two screws B to allow removal of the cover.
- Mount the vacuum switch body to the base, and use the two screws B to secure.
- Use the two screws A to mount the base onto the ejector body.

- Cautions:**
1. During the mounting operation, take care to avoid losing the O-ring. Also, be sure to perform the mounting and removal operations in a location free of foreign objects. Mounting the switch when foreign objects have intruded inside of it could result in air leaks and other defective operation.
 2. For pressure adjustment and wiring instructions, see p.705.

Functions

The Micro Ejector MED07/10 series includes an optional single solenoid valve for controlling supply air, and optional twin solenoid valves for controlling supply air and vacuum breaking air. The unit with twin solenoid valves uses supplied compressed air to the vacuum side to enable vacuum breaking and blow-off release, and makes use of an adjusting needle for vacuum breaking flow to enable flexible setting of machine flow rate. In addition, a built-in check valve ensures that the vacuum level setting can be maintained even when the power to the solenoid valve for controlling supply air has been switched off, attaining energy savings.

● Control circuit for economizing on air consumption volume when the vacuum is being maintained for long periods of time

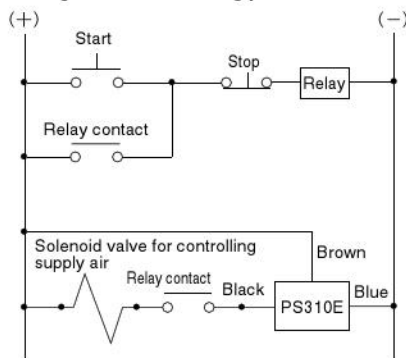

Remark: The above diagram shows the case when the solenoid valve for controlling supply air is normally open (NO; order code: -11).



Piping

1. Connect air supply to the compressed air supply port, and a vacuum pad, etc., to the vacuum generation port.
2. To select the piping direction, use the air supply ports on both end surfaces of the manifold. At time of delivery, a port on one side is temporarily closed off with a plug. Remove the plug and then use sealing tape or other sealing material to re-tighten.
3. For vacuum generation ports, tubes of the following sizes are recommended.
For MED07/10... $\phi 8 \times 6$
N8

Urethane tube of equivalent size is also acceptable.

- Cautions:**
1. Use a fitting that does not reduce inner diameter. A small inner diameter can result in degradation of performance, including flow rate and pressure shortages, insufficient vacuum, or longer periods of time before the vacuum level is reached.
 2. Avoid use of coil tubes and other spiraled piping. Also, avoid use of elbow fittings, etc., between the micro ejector and vacuum pad, and use piping that is as straight as possible.
 3. For multiple manifold use, the upper limit for linked units is as shown below.
MED07 → 10 units
MED10 → Five units
Vacuum levels and suction flows could undergo serious deterioration if operated in excess of the above limits.



Solenoid

Internal circuit

● DC12V, DC24 (surge suppression)

Standard solenoid

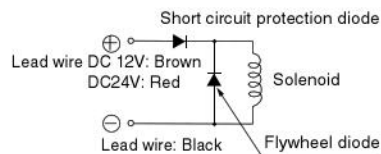

Solenoid with LED indicator

Order code: -PSL, -PLL

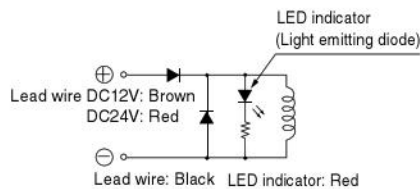

- Cautions:**
1. Do not apply megger between the lead wires.
 2. The DC solenoid will not short circuit even if the wrong polarity is applied, but the valve will not operate.
 3. Leakage current inside the circuit could result in failure of the solenoid valve to return, or other erratic operation. Always use it within the range of the allowable leakage current. In circuit conditions, etc., cause the leakage current to exceed the maximum allowable leakage current, consult us.



Plug connector

Attaching and removing plug connector

Use fingers to insert the connector into the pin, push in until the lever claw latches onto the protruded section on the connector housing, and complete the connection.

To remove the connector, squeeze the lever along with the connector, lift the lever claw up from the protruded section of the connector housing, and pull it out.

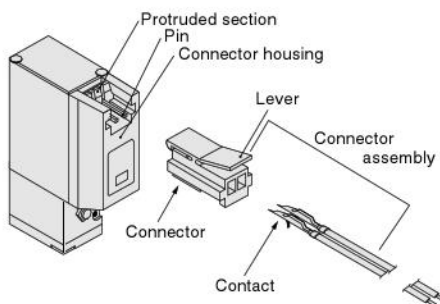

Manual override

Non-locking type

To operate, use a tool with a fine tip (such as a small screwdriver) to press the manual override all the way down. The micro ejector works the same as an energized state as long as the manual override is pushed down, and returns to the reset position upon release.

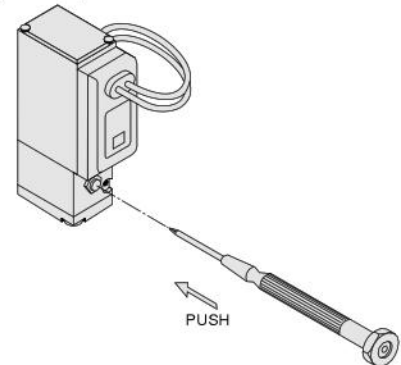

Caution: Do not attempt to operate the manual override with a pin or other object having an extremely fine tip. It could damage the manual override button.



Vacuum breaking

Adjustment of vacuum breaking flow rate

Turning the adjusting needle for vacuum breaking flow rate (with twin solenoid valves only) in the clockwise direction reduces the breaking flow rate, while turning it in the counterclockwise direction increases the breaking flow rate.

