



CAD drawing data catalog  
is available.



# KOGANEI

## ACTUATORS GENERAL CATALOG

MINI BIT CYLINDERS

# MINI BIT CYLINDERS CONTENTS

Features	63
Handling Instructions and Precautions	64
Double Acting Type, Single Acting Push Type	
Specifications	65
Order Codes	66
Major Parts and Materials	67
Dimensions	68
Cylinders for Clean Systems	
Specifications	70
Order Codes	71
Major Parts and Materials	72
Evaluating Clean Room Rating	73
Dimensions	74
Sensor Switches	75



**Caution**

Before use, be sure to read the "Safety Precautions" on p. 57.

**More compact than ever**

# MINI BIT CYLINDERS

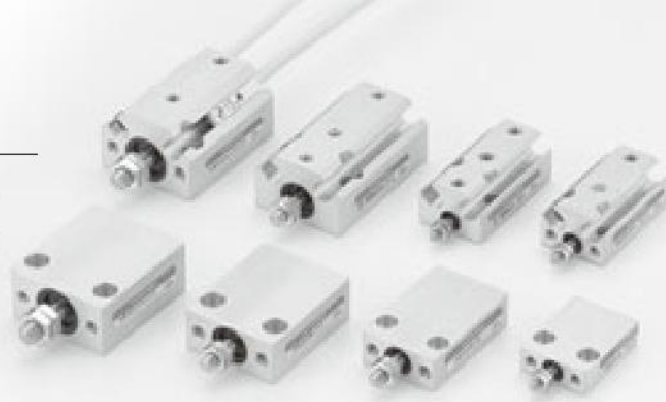

**Smaller than the current compact Multi Mount Cylinders range offering space-saving mounting.**

● **Total length: up to 41% reduction**

● **Volume: up to 67% reduction**

Above data compares the Mini Bit with our standard Multi Mount cylinder without magnet.

Outer dimensions (without magnet)

Bore size	A(A')	B(B')	C(C')
<b>4.5 [0.177]</b>	6 [0.236] (-)	15 [0.591] (-)	16 [0.630] (-)
<b>6 [0.236]</b>	8 [0.315] (12 [0.472])	17 [0.669] (20 [0.787])	16.5 [0.650] (28 [1.102])
<b>8 [0.315]</b>	10 [0.394] (-)	21 [0.827] (-)	16.5 [0.650] (-)
<b>10 [0.394]</b>	12 [0.472] (14 [0.551])	23 [0.906] (24 [0.945])	17 [0.669] (30 [1.181])

Figures in ( ) show the dimensions of our Multi Mount Cylinder BDA series.

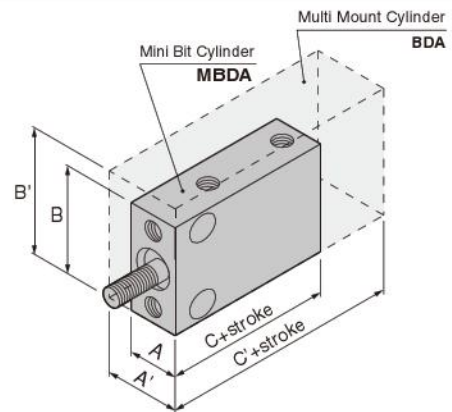

## Short mounting pitch

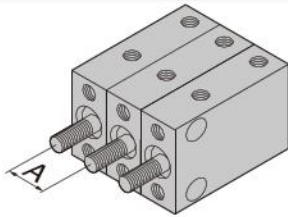

The figures show standard cylinders.

Bore size	A
<b>4.5 [0.177]</b>	6 [0.236]
<b>6 [0.236]</b>	8 [0.315]
<b>8 [0.315]</b>	10 [0.394]
<b>10 [0.394]</b>	12 [0.472]

## Conforms to clean room requirement class 10 <sup>Note</sup>



Note: Obtained by our in-house test procedure and removing dust by suction from the dust collecting port. Refer to p.73 for more details.

## Product range

Bore size mm [in.]	Operation type	Stroke mm						Clean specification	Cylinder with magnet	Plain rod
		4	6	8	10	15	20			
4.5 [0.177]	Double acting type	●	●	●	●	—	—	●	●	●
	Single acting push type	●	●	●	—	—	—	—	●	●
6 [0.236]	Double acting type	●	●	●	●	●	—	●	●	—
	Single acting push type	●	●	●	—	—	—	—	●	—
8 [0.315]	Double acting type	●	●	●	●	●	●	●	●	—
	Single acting push type	●	●	●	●	—	—	—	●	—
10 [0.394]	Double acting type	●	●	●	●	●	●	●	●	—
	Single acting push type	●	●	●	●	—	—	—	●	—

Note: Mini Bit standard cylinders can be used as non-ion (NCU) specification products.

## New type ZE solid state sensor switch

● **Compact**

Total length is 15mm [0.591in.] compared to the current 22mm [0.866in.] (ZE235).

● **Response differential is reduced to 1/2 that of the current switch.** <sup>Note</sup>

● **Maximum sensing location and electric characteristics are not changed.**

Note: According to our in-house test procedure.

## Appropriate fittings and tubes are available

**Fittings (straight, elbow) and tubes (non-conductive, conductive) for Mini Bit Cylinders are available.**

For further details, please see the TAC fittings and Tubes sections in the General Catalog of Air Treatment, Auxiliary, Vacuum (Catalog No. BKUA001).





## General Precautions

### Allowable kinetic energy

When carrying an inertial load, operate the cylinder at a kinetic energy at or below the allowable limit.

Bore size	mm [in.]	4.5 [0.177]	6 [0.236]	8 [0.315]	10 [0.394]
Piston speed	m/s [in./sec.]	0.05~0.5 [2~20]			
Allowable kinetic energy	J [ft·lbf]	2.23×10 <sup>-3</sup> [1.64×10 <sup>-3</sup> ]	3.96×10 <sup>-3</sup> [2.92×10 <sup>-3</sup> ]	7.04×10 <sup>-3</sup> [5.19×10 <sup>-3</sup> ]	10.9×10 <sup>-3</sup> [8.04×10 <sup>-3</sup> ]

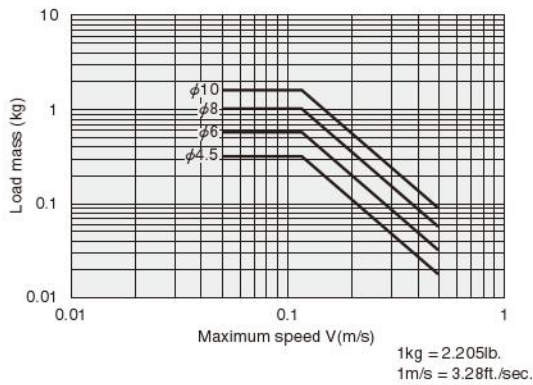

### Mounting

When mounting the Mini Bit Cylinder, tighten the bolts within the range of the tightening torque.

#### ● Mini Bit Cylinder mounting

The Mini Bit Cylinder can be mounted in two directions.

1. Mounting using the through holes on the body

#### Cylinder with magnet

#### Standard cylinder

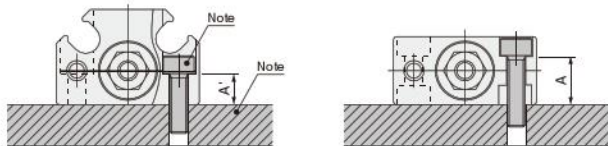

(Note: Do not use magnetic materials for the mounting bracket of the cylinder with magnet.)

Model	Bolt	Maximum tightening torque N·m [in·lbf]	A dimension mm [in.]	A' dimension mm [in.]
MB□A(S)4.5	M2×0.4	0.27 [2.39]	3.8 [0.150]	2.5 [0.098]
MB□A(S)6	M2×0.4	0.27 [2.39]	5.8 [0.228]	4 [0.157]
MB□A(S)8	M2.5×0.45	0.58 [5.13]	7 [0.276]	4.5 [0.177]
MB□A(S)10	M2.5×0.45	0.58 [5.13]	9 [0.354]	5.5 [0.217]

2. Mounting by using bolts in the axial direction

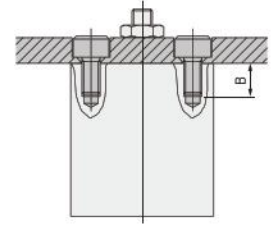

Model	Bolt	Maximum tightening torque N·m [in·lbf]	B dimension mm [in.]
MB□A(S)4.5	M2.5×0.45	0.32 [2.83]	3 [0.118]
MB□A(S)6	M3×0.5	0.59 [5.22]	4 [0.157]
MB□A(S)8	M3×0.5	0.59 [5.22]	4 [0.157]
MB□A(S)10	M3×0.5	0.59 [5.22]	4 [0.157]

### Piping

1. Always thoroughly blow off (use compressed air) the tubing before connecting it to the Mini Bit Cylinder. Entering chips, sealing tape, rust, etc., generated during piping work could result in air leaks or other defective operation.
2. Observe the following tightening torques when screwing piping or fittings into the Mini Bit Cylinder ports.

Connecting thread	Tightening torque N·m [in·lbf]
M3×0.5	0.59 [5.22]

### Media

1. Use air for media. For the use of any other media, consult us.
2. For the air used in the cylinder, use clean air that does not contain deteriorated compressor oil. Install a filter (filtration rating of a minimum 40 μm) near the cylinder or valve to remove collected liquid or dust. Also, clean out the collected liquid of the air filter on a regular basis. Letting liquid or dust inside the cylinder could result in defective operation.

### Lubrication

This product can be used without lubrication, if lubrication is required, use Turbine Oil Class 1 (ISO VG32) or equivalent. Avoid using spindle oil or machine oil.

### Atmosphere

If using in locations subject to dripping water, dripping oil, etc., use a cover to protect the unit.

# MINI BIT CYLINDERS

Double Acting Type, Single Acting Push Type

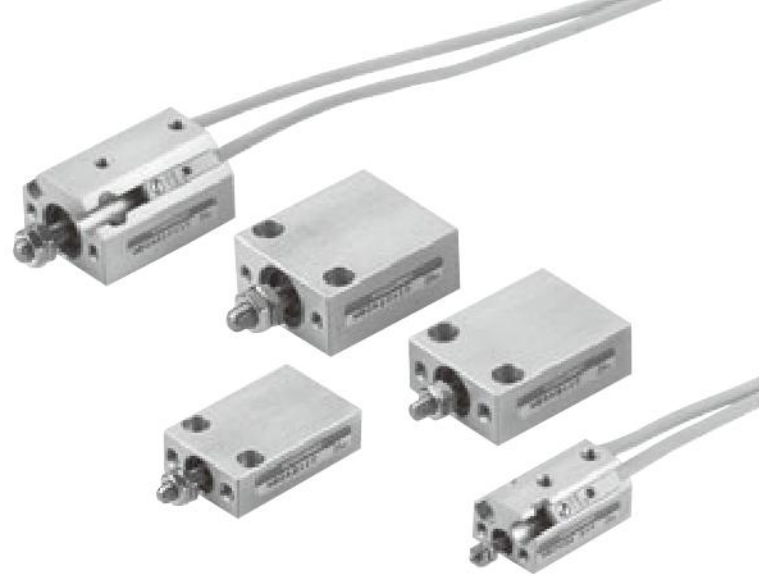

## Symbols

● Double acting type (MBDA) ● Single acting push type (MBSA)

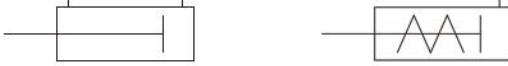

## Specifications

Item		Bore size mm [in.]	4.5 [0.177]	6 [0.236]	8 [0.315]	10 [0.394]
Media			Air			
Operating pressure range MPa [psi.]	Double acting type		0.15~0.7 [22~102]			0.1~0.7 [15~102]
	Single acting push type		0.3~0.7 [44~102]		0.2~0.7 [29~102]	
Proof pressure	MPa [psi.]		1.05 [152]			
Operating temperature range	°C [°F]		0~60 [32~140]			
Operating speed range	mm/s [in./sec.]		50~500 [2.0~19.7]			
Cushion			None			
Lubrication			Not required (If lubrication is required, use Turbine Oil Class 1 (ISO VG32) or equivalent.)			
Port size			M3			
Stroke tolerance	mm [in.]		+ <sup>0.5</sup> <sub>0</sub> [ + <sup>0.020</sup> <sub>0</sub> ]			

## Cylinder Thrust

Bore size mm [in.]	Piston rod diameter mm [in.]	Operating type	Operating direction	Pressure area mm <sup>2</sup> [in. <sup>2</sup> ]	Air pressure MPa [psi.]						
					N [lbf.]						
					0.1 [15]	0.2 [29]	0.3 [44]	0.4 [58]	0.5 [73]	0.6 [87]	0.7 [102]
4.5 [0.177]	2 [0.079]	Double acting type	Push side	15.9 [0.0246]	—	3.2 [0.72]	4.8 [1.08]	6.4 [1.44]	8.0 [1.80]	9.5 [2.14]	11.1 [2.50]
			Pull side	12.8 [0.0198]	—	2.6 [0.58]	3.8 [0.85]	5.1 [1.15]	6.4 [1.44]	7.7 [1.73]	9.0 [2.02]
		Single acting push type		15.9 [0.0246]	—	—	1.9 [0.43]	3.5 [0.79]	5.1 [1.15]	6.6 [1.48]	8.2 [1.84]
6 [0.236]	3 [0.118]	Double acting type	Push side	28.2 [0.0437]	—	5.6 [1.26]	8.5 [1.91]	11.3 [2.54]	14.1 [3.17]	16.9 [3.80]	19.7 [4.43]
			Pull side	21.2 [0.0329]	—	4.2 [0.94]	6.4 [1.44]	8.5 [1.91]	10.6 [2.38]	12.7 [2.85]	14.8 [3.33]
		Single acting push type		28.2 [0.0437]	—	—	5.1 [1.15]	7.9 [1.78]	10.7 [2.41]	13.5 [3.03]	16.3 [3.66]
8 [0.315]	3 [0.118]	Double acting type	Push side	50.3 [0.0780]	—	10.1 [2.27]	15.1 [3.39]	20.1 [4.52]	25.2 [5.66]	30.2 [6.79]	35.2 [7.91]
			Pull side	43.2 [0.0670]	—	8.6 [1.93]	13.0 [2.92]	17.3 [3.89]	21.6 [4.86]	25.9 [5.82]	30.2 [6.79]
		Single acting push type		50.3 [0.0780]	—	5.0 [1.12]	10.0 [2.25]	15.0 [3.37]	20.1 [4.52]	25.1 [5.64]	30.1 [6.77]
10 [0.394]	4 [0.157]	Double acting type	Push side	78.5 [0.1216]	7.9 [1.78]	15.7 [3.53]	23.6 [5.31]	31.4 [7.06]	39.3 [8.83]	47.1 [10.59]	55.0 [12.36]
			Pull side	65.9 [0.1021]	6.6 [1.48]	13.2 [2.97]	19.8 [4.45]	26.4 [5.93]	33.0 [7.42]	39.5 [8.88]	46.1 [10.36]
		Single acting push type		78.5 [0.1216]	—	8.0 [1.80]	15.9 [3.57]	23.7 [5.33]	31.6 [7.10]	39.4 [8.86]	47.3 [10.63]

## Spring Return Force (for single acting type only)

Bore size mm [in.]	State of cylinder	Stroke mm [in.]			
		4 [0.157]	6 [0.236]	8 [0.315]	10 [0.394]
4.5 [0.177]	Zero stroke	2.04 [0.459]	1.59 [0.357]	1.13 [0.254]	—
	Stroke end	2.95 [0.663]	2.95 [0.663]	2.95 [0.663]	—
6 [0.236]	Zero stroke	2.54 [0.571]	2.15 [0.483]	1.76 [0.396]	—
	Stroke end	3.43 [0.771]	3.43 [0.771]	3.43 [0.771]	—
8 [0.315]	Zero stroke	3.76 [0.845]	3.07 [0.690]	2.39 [0.537]	1.71 [0.384]
	Stroke end	5.13 [1.153]	5.13 [1.153]	5.13 [1.153]	5.13 [1.153]
10 [0.394]	Zero stroke	5.48 [1.232]	4.39 [0.987]	3.29 [0.740]	2.19 [0.492]
	Stroke end	7.74 [1.740]	7.74 [1.740]	7.74 [1.740]	7.74 [1.740]

## Operation Type, Bore Size, and Stroke

Operation type	Bore size	Standard strokes
		mm
Double acting type	4.5	4, 6, 8, 10
	6	4, 6, 8, 10, 15
	8	4, 6, 8, 10, 15, 20
	10	
Single acting push type	4.5	4, 6, 8
	6	
	8	4, 6, 8, 10
	10	

# Mass

## Double acting type

g [oz.]

Bore size mm	Stroke mm	Standard cylinder	Cylinder with magnet	Additional mass	
				Sensor switch (1 switch)	
				ZE□□□A	ZE□□□B
4.5	4	5.1 [0.180]	8.0 [0.282]	15 [0.529]	35 [1.235]
	6	5.6 [0.198]	8.6 [0.303]		
	8	6.1 [0.215]	9.2 [0.325]		
	10	6.6 [0.233]	9.8 [0.346]		
6	4	8.5 [0.300]	11.3 [0.399]	15 [0.529]	35 [1.235]
	6	9.2 [0.325]	12.1 [0.427]		
	8	9.9 [0.349]	12.9 [0.455]		
	10	10.6 [0.374]	13.7 [0.483]		
	15	12.4 [0.437]	15.7 [0.554]		
8	4	11.7 [0.413]	15.2 [0.536]	15 [0.529]	35 [1.235]
	6	12.7 [0.448]	16.3 [0.575]		
	8	13.7 [0.483]	17.4 [0.614]		
	10	14.7 [0.519]	18.5 [0.653]		
	15	17.2 [0.607]	21.3 [0.751]		
	20	19.7 [0.695]	24.1 [0.850]		
10	4	16.4 [0.578]	20.3 [0.716]	15 [0.529]	35 [1.235]
	6	17.7 [0.624]	21.7 [0.765]		
	8	19.0 [0.670]	23.1 [0.815]		
	10	20.3 [0.716]	24.5 [0.864]		
	15	23.6 [0.832]	28.0 [0.988]		
	20	26.9 [0.949]	31.5 [1.111]		

## Single acting push type

g [oz.]

Bore size mm	Stroke mm	Standard cylinder	Cylinder with magnet	Additional mass	
				Sensor switch (1 switch)	
				ZE□□□A	ZE□□□B
4.5	4	5.7 [0.201]	8.8 [0.310]	15 [0.529]	35 [1.235]
	6	6.2 [0.219]	9.4 [0.332]		
	8	6.7 [0.236]	10.0 [0.353]		
6	4	9.4 [0.332]	12.3 [0.434]	15 [0.529]	35 [1.235]
	6	10.1 [0.356]	13.1 [0.462]		
	8	10.8 [0.381]	13.9 [0.490]		
8	4	13.0 [0.459]	16.7 [0.589]	15 [0.529]	35 [1.235]
	6	14.0 [0.494]	17.8 [0.628]		
	8	15.0 [0.529]	18.9 [0.667]		
	10	16.0 [0.564]	20.0 [0.705]		
10	4	18.2 [0.642]	22.2 [0.783]	15 [0.529]	35 [1.235]
	6	19.5 [0.688]	23.6 [0.832]		
	8	20.8 [0.734]	25.0 [0.882]		
	10	22.1 [0.780]	26.4 [0.931]		

## Order Codes

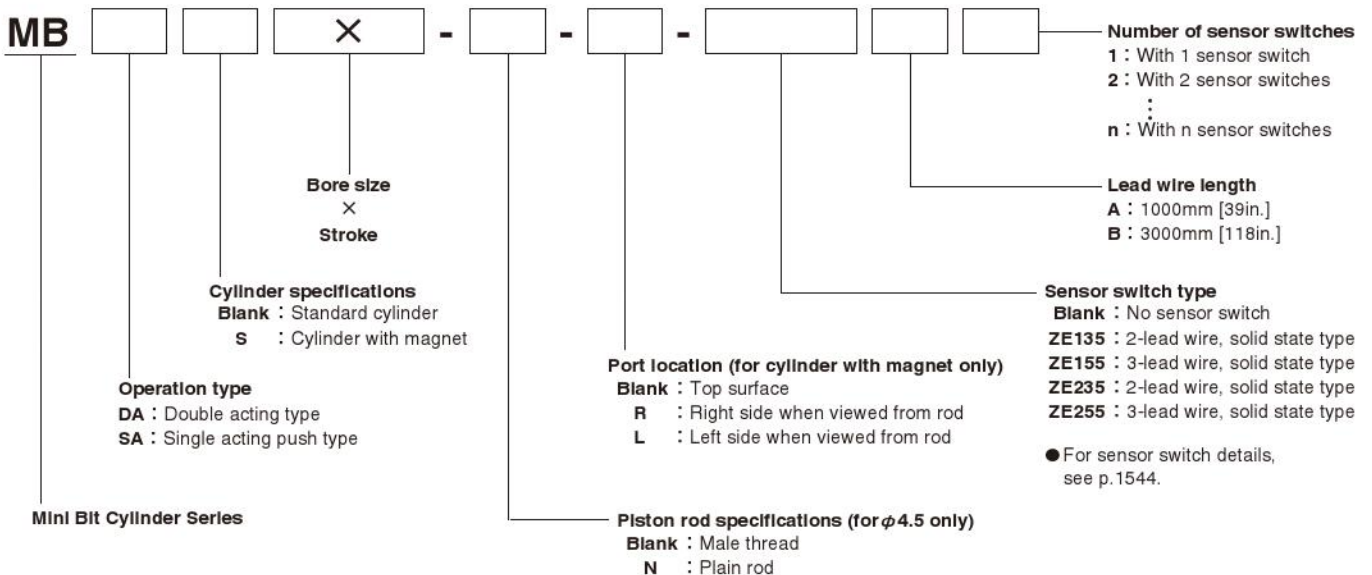

# Inner Constructions

## ● Double acting type

### MBDAS4.5, 6

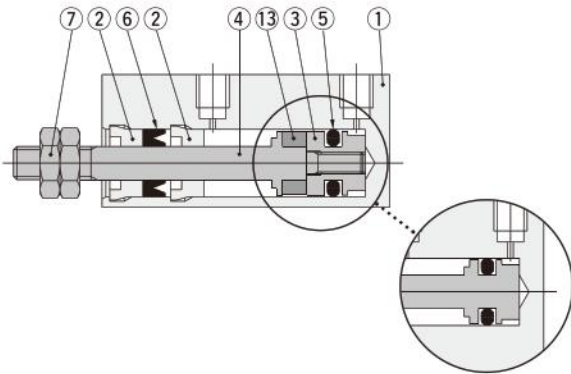

MBDA4.5, 6

### MBDAS8, 10

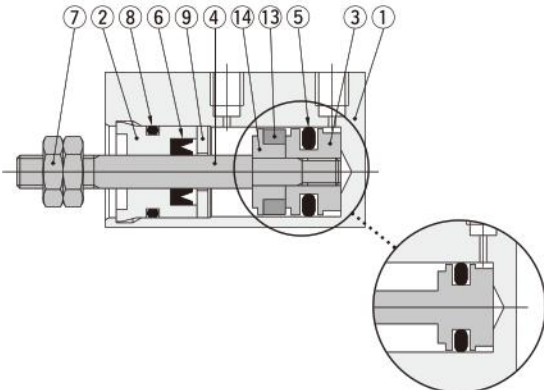

MBDA8

### MBDA10

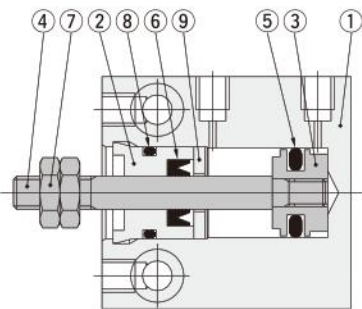

## ● Single acting push type

### MBSAS4.5, 6

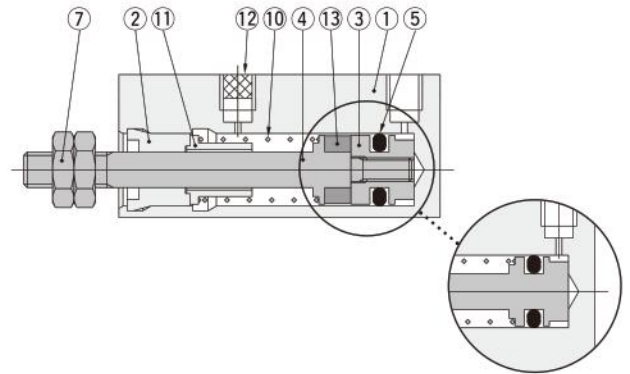

MBSA4.5, 6

### MBSAS8, 10

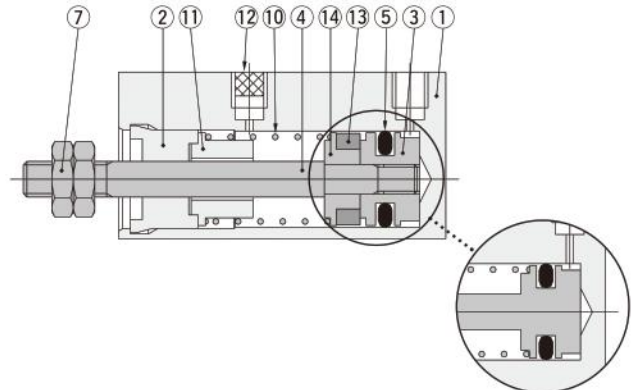

MBSA8

### MBSA10

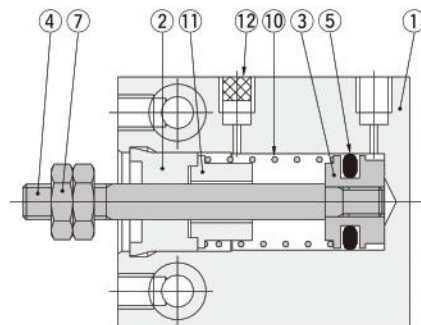

## Major Parts and Materials

		mm [in.]			
No.	Bore size Parts	4.5 [0.177]	6 [0.236]	8 [0.315]	10 [0.394]
①	Body	Aluminum alloy (anodized)			
②	Rod cap	Oil impregnated plastic bushing (polyacetal)			
③	Piston <sup>Note</sup>	Aluminum alloy (special rust prevention treatment)			
④	Piston rod	Stainless steel			
⑤	Piston seal	Synthetic rubber (NBR)			
⑥	Rod seal	Synthetic rubber (NBR)			
⑦	Rod end nut	Stainless steel	Mild steel (nickel plated)		
⑧	O-ring	Synthetic rubber (NBR)			

		mm [in.]			
No.	Bore size Parts	4.5 [0.177]	6 [0.236]	8 [0.315]	10 [0.394]
⑨	Seal holder	—		Aluminum alloy (special rust prevention treatment)	
⑩	Spring	Steel (zinc plated)			
⑪	Stopper	Aluminum alloy (special rust prevention treatment)			
⑫	Filter	Foamed metal			
⑬	Magnet	Neodymium magnet			
⑭	Support	—		Aluminum alloy (special rust prevention treatment)	

Note: Material for MBDA4.5, 6, 8 and MBSA4.5, 6, 8 is stainless steel, and the piston is one-piece construction with the piston rod.

Dimensions (mm)

● Double acting type (standard cylinder)  
MBDA4.5, 6, 8, 10

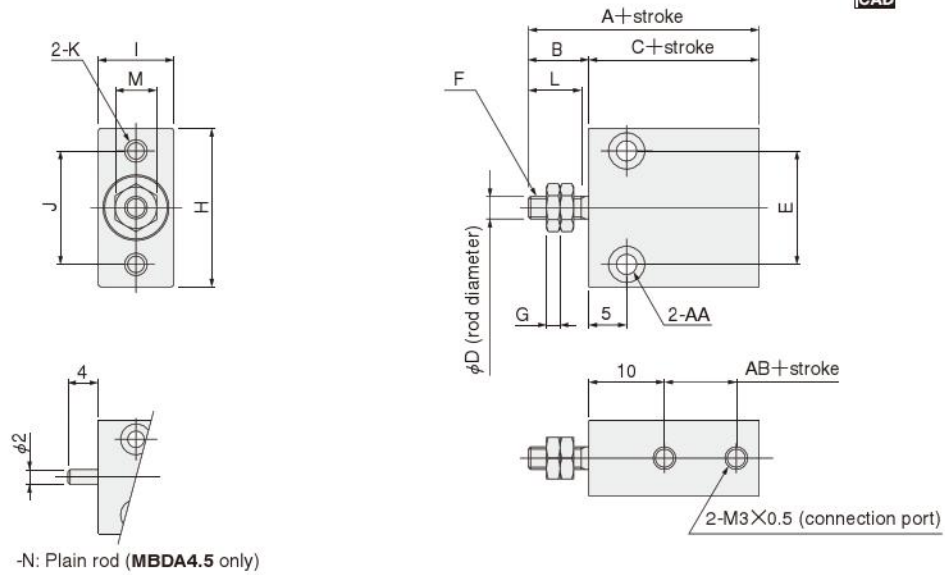

Model	Code	A	B	C	D	E	F	G	H	I	J	K	L	M	AA	AB
MBDA4.5	23	7	16	2	10	M2×0.4	1.6	15	6	10	M2.5×0.45 Depth3	6	4	φ2.2 Counterbore φ4.1 Depth 2.2 (both sides)	3	
MBDA6	24.5	8	16.5	3	12	M3×0.5	1.8	17	8	12	M3×0.5 Depth4	7	5.5	φ2.2 Counterbore φ4.1 Depth 2.2 (both sides)	3.5	
MBDA8	24.5	8	16.5	3	15	M3×0.5	1.8	21	10	15	M3×0.5 Depth4	7	5.5	φ2.7 Counterbore φ4.8 Depth 3 (both sides)	3.5	
MBDA10	27	10	17	4	17	M4×0.7	2.4	23	12	17	M3×0.5 Depth4	9	7	φ2.7 Counterbore φ4.8 Depth 3 (both sides)	4	

● Double acting type (cylinder with magnet)  
MBDAS4.5, 6, 8, 10

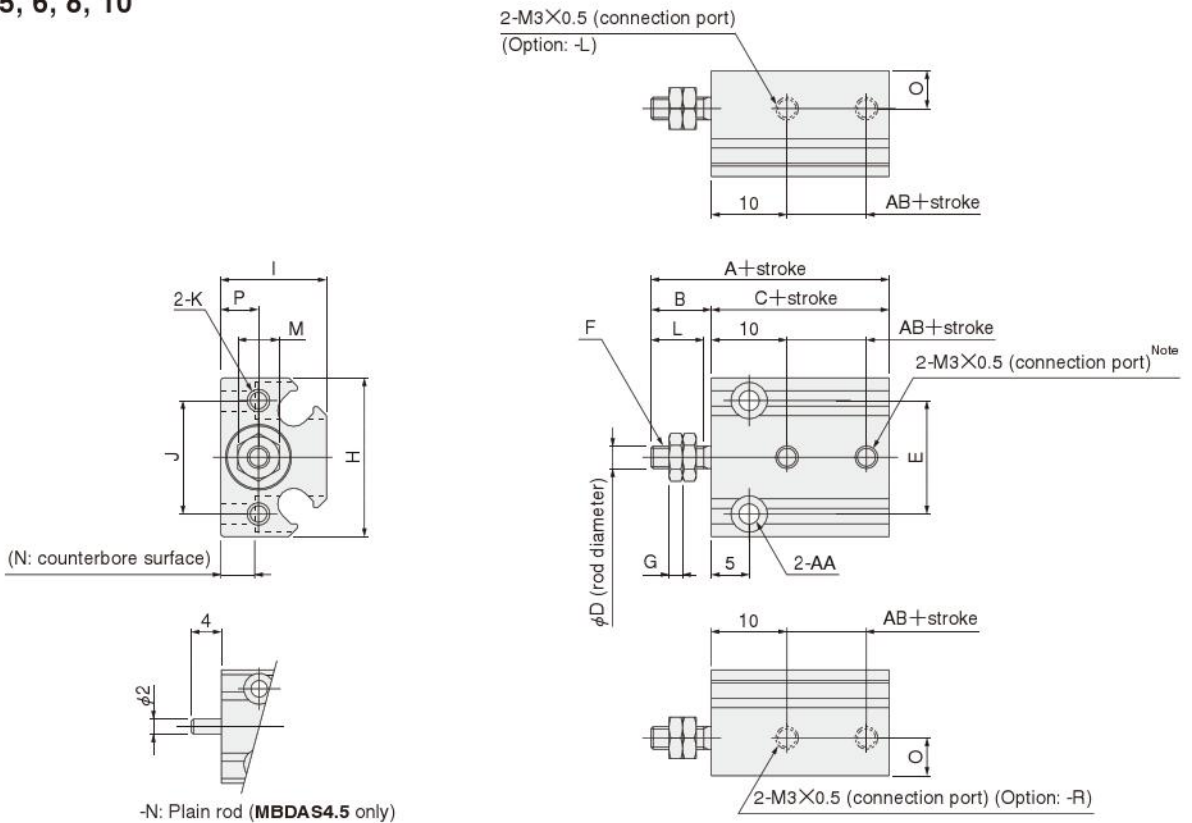

Note: When selecting the optional port location code -R or -L, the standard connection port comes with a plug.

Model	Code	A	B	C	D	E	F	G	H	I	J	K	L	M	N	O	P	AA	AB
MBDAS4.5	27	7	20	2	10	M2×0.4	1.6	15	11	10	M2.5×0.45 Depth 3	6	4	2.5	2.8	3	φ2.2 Counterbore φ4.1 Depth 8.5	7	
MBDAS6	28	8	20	3	12	M3×0.5	1.8	17	12	12	M3×0.5 Depth 4	7	5.5	4	4	4	φ2.2 Counterbore φ4.1 Depth 8	7	
MBDAS8	27.5	8	19.5	3	15	M3×0.5	1.8	21	14	15	M3×0.5 Depth 4	7	5.5	4.5	5	5	φ2.7 Counterbore φ4.8 Depth 9.5	6.5	
MBDAS10	30	10	20	4	17	M4×0.7	2.4	23	16	17	M3×0.5 Depth 4	9	7	5.5	6	6	φ2.7 Counterbore φ4.8 Depth 10.5	7	

## Dimensions (mm)

### ● Single acting push type (standard cylinder) MBSA4.5, 6, 8, 10

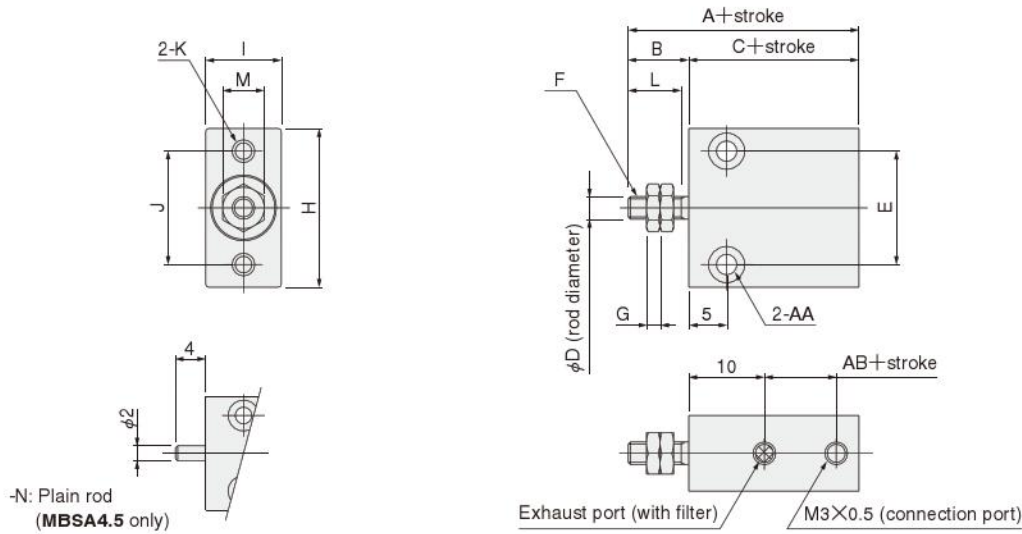

Model	Code	A	B	C	D	E	F	G	H	I	J	K	L	M	AA	AB
MBSA4.5		25	7	18	2	10	M2×0.4	1.6	15	6	10	M2.5×0.45 Depth 3	6	4	φ2.2 Counterbore φ4.1 Depth 2.2 (both sides)	5
MBSA6		26.5	8	18.5	3	12	M3×0.5	1.8	17	8	12	M3×0.5 Depth 4	7	5.5	φ2.2 Counterbore φ4.1 Depth 2.2 (both sides)	5.5
MBSA8		26.5	8	18.5	3	15	M3×0.5	1.8	21	10	15	M3×0.5 Depth 4	7	5.5	φ2.7 Counterbore φ4.8 Depth 3 (both sides)	5.5
MBSA10		29	10	19	4	17	M4×0.7	2.4	23	12	17	M3×0.5 Depth 4	9	7	φ2.7 Counterbore φ4.8 Depth 3 (both sides)	6

### ● Single acting push type (cylinder with magnet) MBSAS4.5, 6, 8, 10

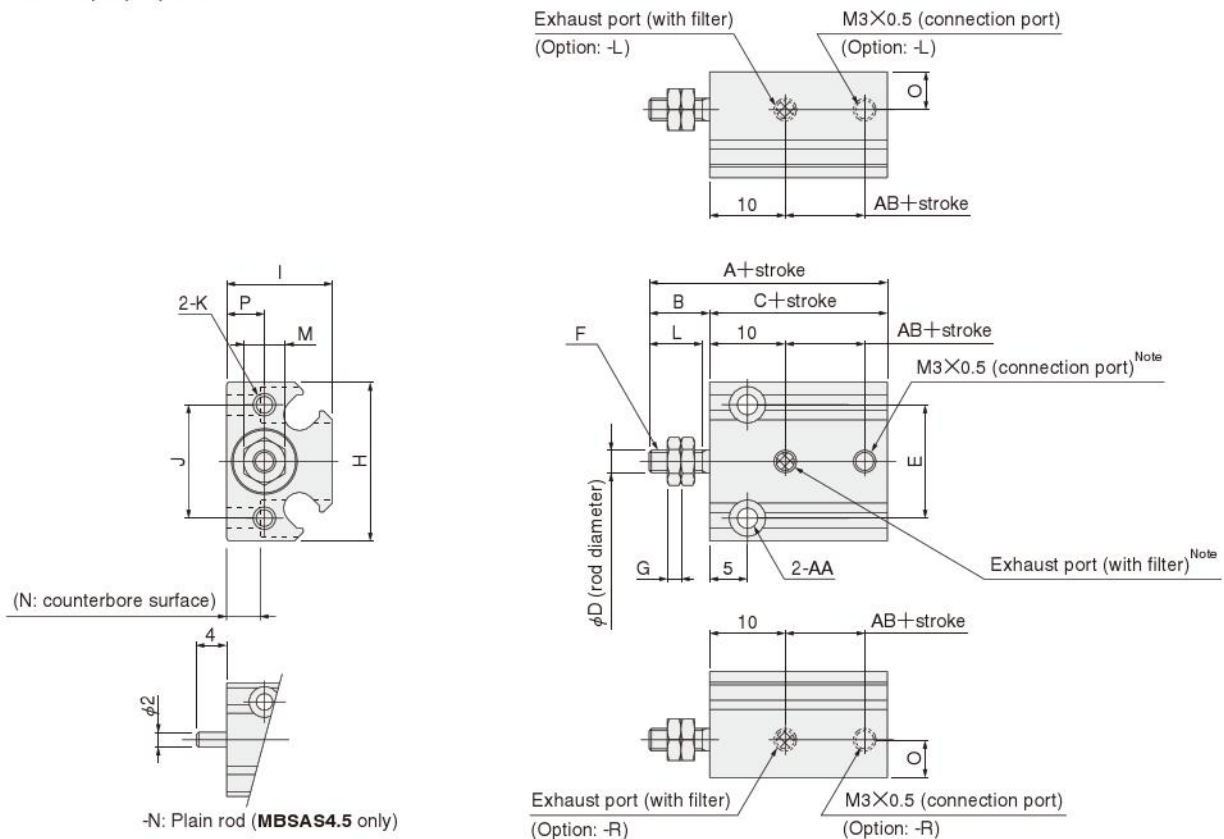

Note: When selecting the optional port location code -R or -L, the standard connection port and exhaust port come with plugs.

Model	Code	A	B	C	D	E	F	G	H	I	J	K	L	M	N	O	P	AA	AB
MBSAS4.5		29	7	22	2	10	M2×0.4	1.6	15	11	10	M2.5×0.45 Depth 3	6	4	2.5	2.8	3	φ2.2 Counterbore φ4.1 Depth 8.5	9
MBSAS6		30	8	22	3	12	M3×0.5	1.8	17	12	12	M3×0.5 Depth 4	7	5.5	4	4	4	φ2.2 Counterbore φ4.1 Depth 8	9
MBSAS8		29.5	8	21.5	3	15	M3×0.5	1.8	21	14	15	M3×0.5 Depth 4	7	5.5	4.5	5	5	φ2.7 Counterbore φ4.8 Depth 9.5	8.5
MBSAS10		32	10	22	4	17	M4×0.7	2.4	23	16	17	M3×0.5 Depth 4	9	7	5.5	6	6	φ2.7 Counterbore φ4.8 Depth 10.5	9

# MINI BIT CYLINDERS

Cylinders for Clean Systems



## Symbol

● Double acting type (CS-MBDA)

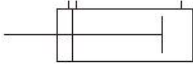

## Specifications

Item		Bore size mm [in.]	4.5 [0.177]	6 [0.236]	8 [0.315]	10 [0.394]
Media			Air			
Operating pressure range MPa [psi.]	Double acting type		0.15~0.7 [22~102]		0.1~0.7 [15~102]	
Proof pressure	MPa [psi.]		1.05 [152]			
Clean room rating			Class 4 or its equivalent (Corresponds to FED-STD 209E Class 10) (In the case of vacuum suction from a dust collection port; by in-house standards. For details, see p.73.)			
Operating temperature range	°C [°F]		0~60 [32~140]			
Operating speed range	mm/s [in./sec.]		50~500 [2.0~19.7]			
Cushion			None			
Lubrication			Prohibited			
Port size			M3			
Stroke tolerance	mm [in.]		$\begin{matrix} +0.5 \\ 0 \end{matrix}$ [ $\begin{matrix} +0.020 \\ 0 \end{matrix}$ ]			

## Cylinder Thrust

Bore size mm [in.]	Piston rod diameter mm [in.]	Operation type	Operating direction	Pressure area mm <sup>2</sup> [in. <sup>2</sup> ]	Air pressure MPa [psi.]						
					0.1 [15]	0.2 [29]	0.3 [44]	0.4 [58]	0.5 [73]	0.6 [87]	0.7 [102]
4.5 [0.177]	2 [0.079]	Double acting type	Push side	15.9 [0.0246]	—	3.2 [0.72]	4.8 [1.08]	6.4 [1.44]	8.0 [1.80]	9.5 [2.14]	11.1 [2.50]
			Pull side	12.8 [0.0198]	—	2.6 [0.58]	3.8 [0.85]	5.1 [1.15]	6.4 [1.44]	7.7 [1.73]	9.0 [2.02]
6 [0.236]	3 [0.118]	Double acting type	Push side	28.2 [0.0437]	—	5.6 [1.26]	8.5 [1.91]	11.3 [2.54]	14.1 [3.17]	16.9 [3.80]	19.7 [4.43]
			Pull side	21.2 [0.0329]	—	4.2 [0.94]	6.4 [1.44]	8.5 [1.91]	10.6 [2.38]	12.7 [2.85]	14.8 [3.33]
8 [0.315]	3 [0.118]	Double acting type	Push side	50.3 [0.0780]	—	10.1 [2.27]	15.1 [3.39]	20.1 [4.52]	25.2 [5.66]	30.2 [6.79]	35.2 [7.91]
			Pull side	43.2 [0.0670]	—	8.6 [1.93]	13.0 [2.92]	17.3 [3.89]	21.6 [4.86]	25.9 [5.82]	30.2 [6.79]
10 [0.394]	4 [0.157]	Double acting type	Push side	78.5 [0.1216]	7.9 [1.78]	15.7 [3.53]	23.6 [5.31]	31.4 [7.06]	39.3 [8.83]	47.1 [10.59]	55.0 [12.36]
			Pull side	65.9 [0.1021]	6.6 [1.48]	13.2 [2.97]	19.8 [4.45]	26.4 [5.93]	33.0 [7.42]	39.5 [8.88]	46.1 [10.36]

## Operation Type, Bore Size, and Stroke

Operation type	Bore size	Standard strokes
Double acting type	4.5	4, 6, 8, 10
	6	4, 6, 8, 10, 15
	8	4, 6, 8, 10, 15, 20
	10	

# Mass

## CS specification (double acting type)

g [oz.]

Bore size mm	Stroke mm	Standard cylinder	Cylinder with magnet	Additional mass	
				Sensor switch (1 switch)	
				ZE□□□A	ZE□□□B
4.5	4	6.0 [0.212]	9.2 [0.325]	15 [0.529]	35 [1.235]
	6	6.5 [0.229]	9.8 [0.346]		
	8	7.0 [0.247]	10.4 [0.367]		
	10	7.5 [0.265]	11.0 [0.388]		
6	4	9.9 [0.349]	12.9 [0.455]	15 [0.529]	35 [1.235]
	6	10.6 [0.374]	13.7 [0.483]		
	8	11.3 [0.399]	14.5 [0.511]		
	10	12.0 [0.423]	15.3 [0.540]		
	15	13.8 [0.487]	17.3 [0.610]		
8	4	13.8 [0.487]	17.6 [0.621]	15 [0.529]	35 [1.235]
	6	14.7 [0.519]	18.7 [0.660]		
	8	15.7 [0.554]	19.8 [0.698]		
	10	16.7 [0.589]	20.9 [0.737]		
	15	19.2 [0.677]	23.7 [0.836]		
	20	21.7 [0.765]	26.5 [0.935]		
10	4	19.3 [0.681]	23.4 [0.825]	15 [0.529]	35 [1.235]
	6	20.6 [0.727]	24.8 [0.875]		
	8	21.9 [0.772]	26.2 [0.924]		
	10	23.2 [0.818]	27.6 [0.974]		
	15	26.6 [0.938]	31.1 [1.097]		
	20	29.9 [1.055]	34.6 [1.220]		

## Order Codes

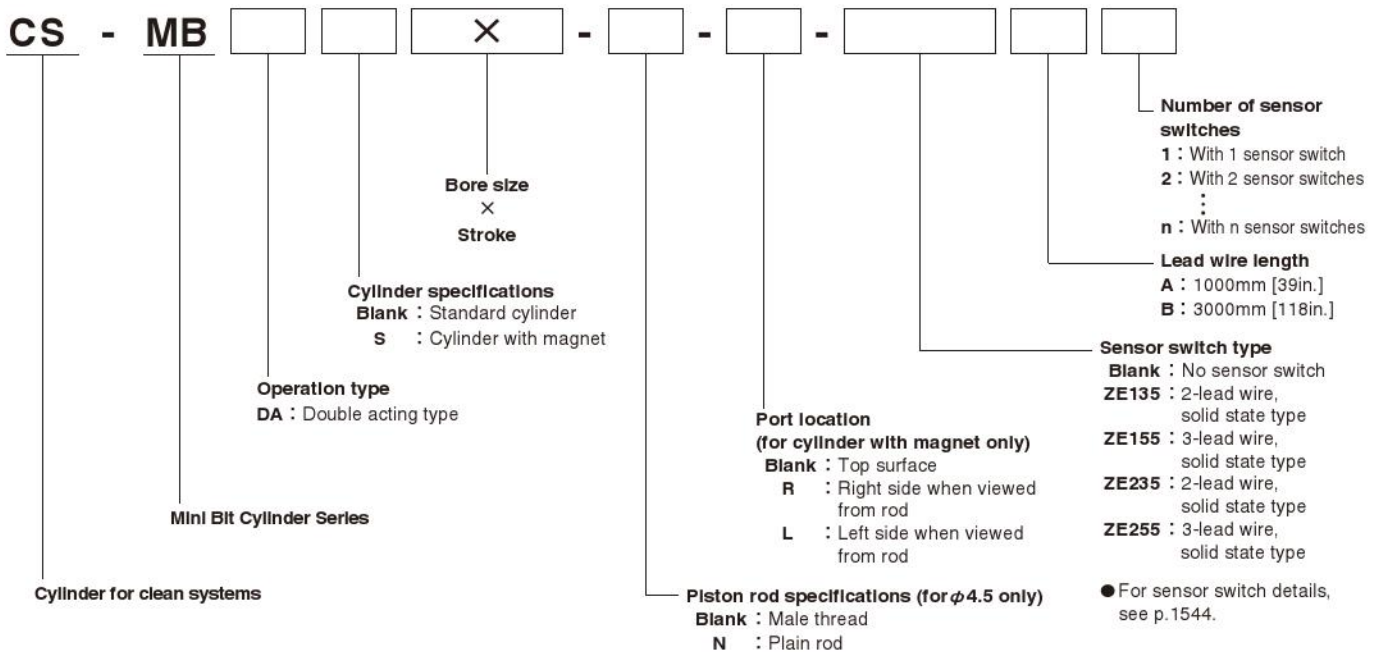

## Inner Constructions

### ● Double acting type for CS CS-MBDAS4.5, 6

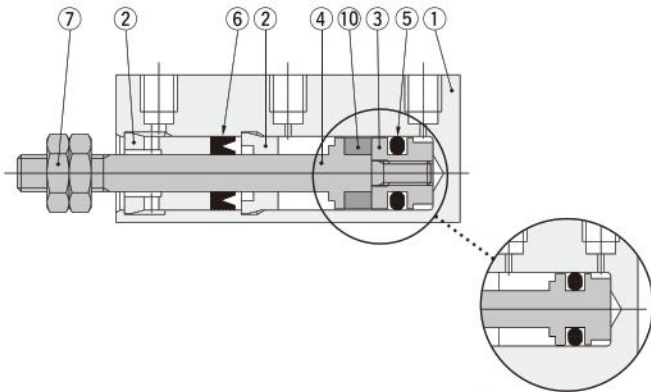

CS-MBDA4.5, 6

### CS-MBDAS8, 10

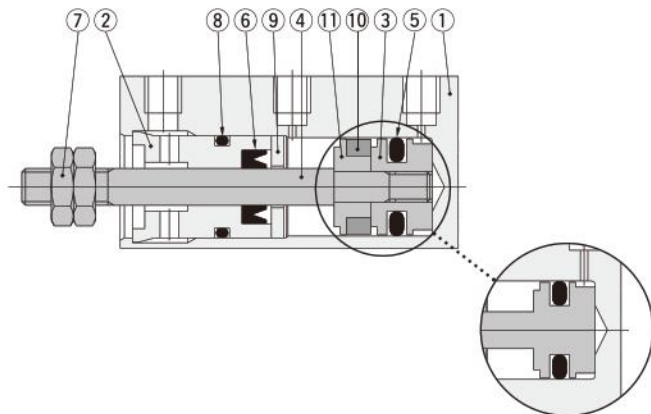

CS-MBDA8

### CS-MBDA10

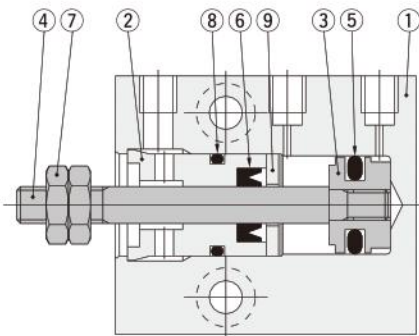

## Major Parts and Materials

		mm [in.]			
No.	Parts	Bore size 4.5 [0.177]	6 [0.236]	8 [0.315]	10 [0.394]
①	Body	Aluminum alloy (anodized)			
②	Rod cap	Oil impregnated plastic bushing (polyacetal)			
③	Piston <sup>Note</sup>	Aluminum alloy (special rust prevention treatment)			
④	Piston rod	Stainless steel			
⑤	Piston seal	Synthetic rubber (NBR)			
⑥	Rod seal	Synthetic rubber (NBR)			
⑦	Rod end nut	Stainless steel	Mild steel (nickel plated)		
⑧	O-ring	—		Synthetic rubber (NBR)	
⑨	Seal holder	—		Aluminum alloy (special rust prevention treatment)	
⑩	Magnet	Neodymium magnet			
⑪	Support	—		Aluminum alloy (special rust prevention treatment)	

Note: Material for **CS-MBDA4.5, 6, 8** is stainless steel, and the piston is one-piece construction with the piston rod.

# Evaluating Clean Room Rating

At present, there is no standard at JIS or elsewhere for methods of evaluating the clean room rating in the clean room specification pneumatic equipment. Koganei has therefore specified its in-house measurement methods, to conduct evaluations on the clean room rating.

The number of particles of the Mini Bit Cylinder Clean Specification is measured as shown in the method below.

## 1. Measurement sample

$\phi 4.5 \times 6$ ,  $\phi 6 \times 6$ ,  $\phi 8 \times 6$ ,  $\phi 10 \times 6$  3 units each, for total of 12 units

## 2. Measurement conditions

2-1 Test circuit: Figure 1 (no suction), Figure 2 (with suction)

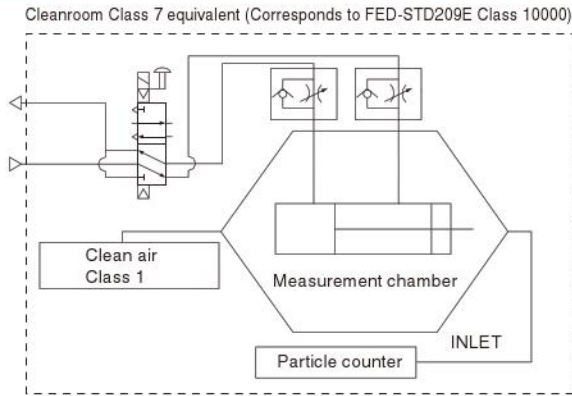

Figure 1

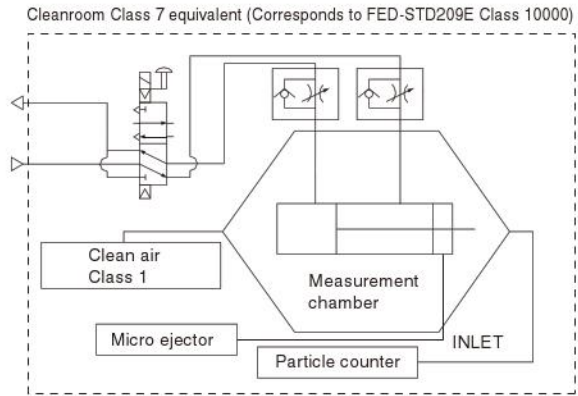

Figure 2

2-2 Operating conditions of tested cylinders

Operating frequency: 1Hz

Average speed: 500mm/s [19.7in./sec.]

Applied pressure: 0.5MPa [73psi.]

Suction condition: Microejector ME05, 0.5MPa [73psi.] applied at primary side,  $\phi 6$  tube

Mounting direction: Vertical

Chamber volume: 8.3 l [0.29ft<sup>3</sup>]

## 3. Particle counter

Manufacturer/model: RION/KM20

Suction rate: 28.3 l /min [1ft<sup>3</sup>/min]

Particle diameter: 0.1  $\mu$ m, 0.2  $\mu$ m, 0.3  $\mu$ m, 0.5  $\mu$ m, 0.7  $\mu$ m, 1.0  $\mu$ m

## 4. Measurement method

4-1 Confirmation of number of particles in the measurement system

Under the conditions in the above 1 and 2, using a particle counter to measure the sample for 9 minutes without operating it, and confirmed the measured particle is 1 piece or less.

4-2 Actual measurement

Under the conditions in the above 1 and 2, operating the sample for 36 minutes, and measured the total values in the latter half of 18 minutes test.

4-3 Reconfirmation

Performed the measurement in 4-1 again, to reconfirm the number of particles in the measurement system.

## 5. Measurement results (for $\phi 10 \times 6$ )

Note: The following graphs were obtained by measurements after 1 million product operations.

### ● No suction from dust collection port

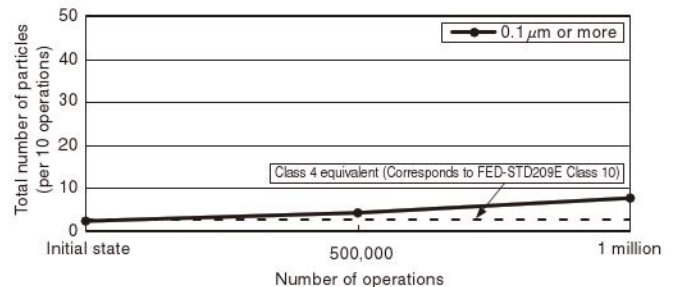
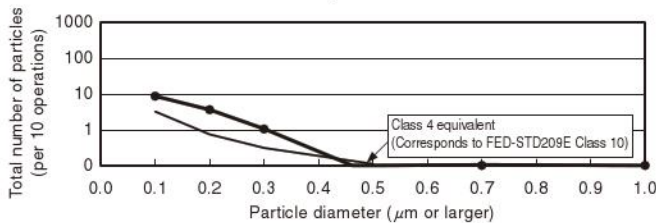

### ● With suction from dust collection port

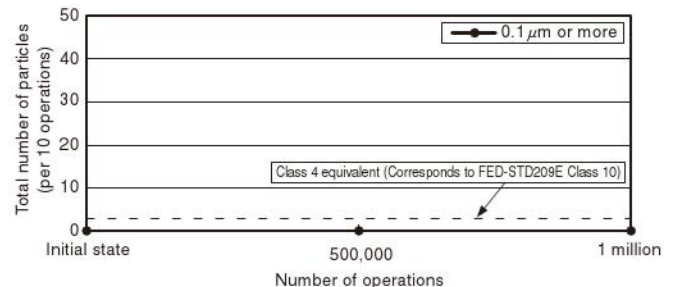
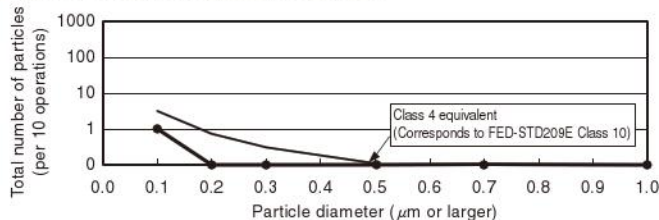

Dimensions (mm)

● Double acting type for CS (standard cylinder)

CS-MBDA4.5, 6, 8, 10

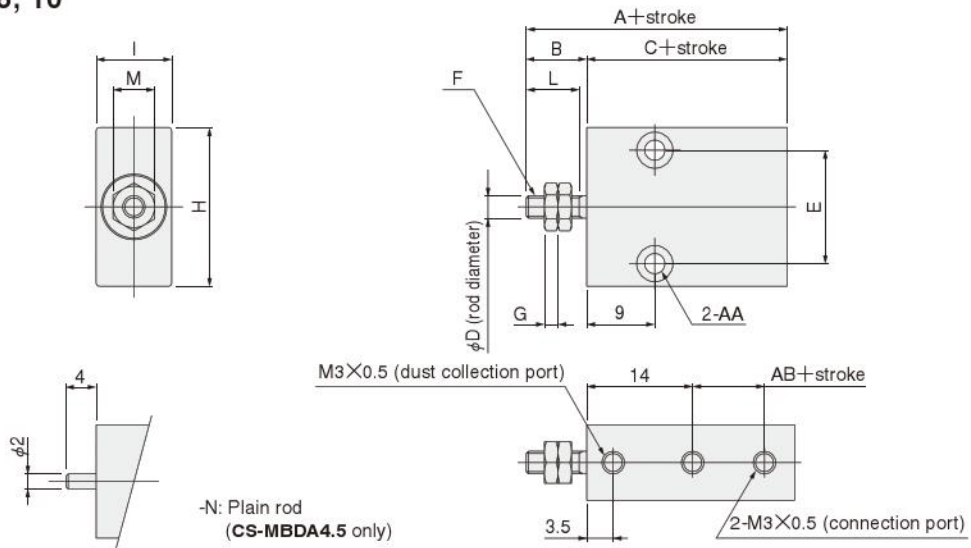

Model	Code	A	B	C	D	E	F	G	H	I	L	M	AA	AB
CS-MBDA4.5		27	7	20	2	10	M2×0.4	1.6	15	6	6	4	φ2.2 Counterbore φ4.1 Depth 2.2 (both sides)	3
CS-MBDA6		28.5	8	20.5	3	12	M3×0.5	1.8	17	8	7	5.5	φ2.2 Counterbore φ4.1 Depth 2.2 (both sides)	3.5
CS-MBDA8		28.5	8	20.5	3	15	M3×0.5	1.8	21	10	7	5.5	φ2.7 Counterbore φ4.8 Depth 3 (both sides)	3.5
CS-MBDA10		31	10	21	4	17	M4×0.7	2.4	23	12	9	7	φ2.7 Counterbore φ4.8 Depth 3 (both sides)	4

● Double acting type for CS (cylinder with magnet)

CS-MBDAS4.5, 6, 8, 10

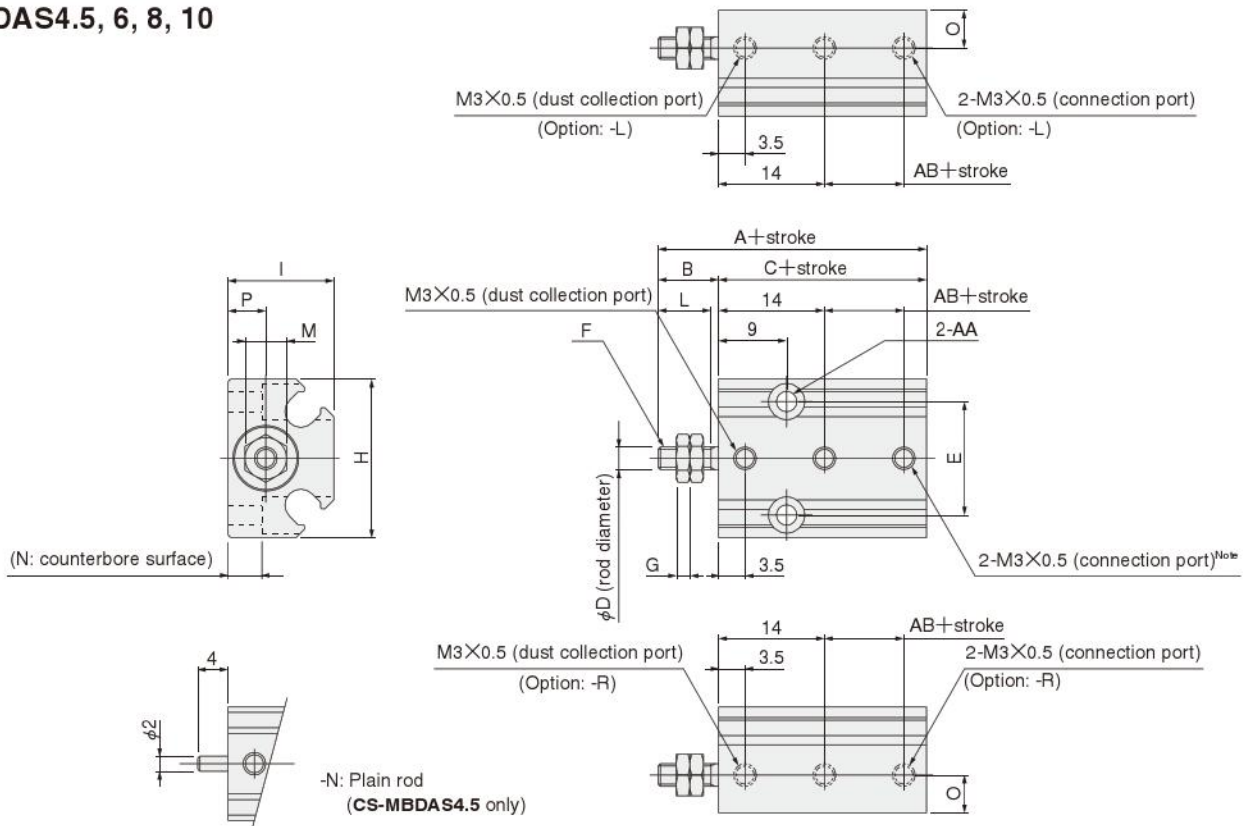

Note: When selecting the optional port location code -R or -L, the standard connection port comes with a plug.

Model	Code	A	B	C	D	E	F	G	H	I	L	M	N	O	P	AA	AB
CS-MBDAS4.5		31	7	24	2	10	M2×0.4	1.6	15	11	6	4	2.5	2.8	3	φ2.2 Counterbore φ4.1 Depth 8.5	7
CS-MBDAS6		32	8	24	3	12	M3×0.5	1.8	17	12	7	5.5	4	4	4	φ2.2 Counterbore φ4.1 Depth 8	7
CS-MBDAS8		31.5	8	23.5	3	15	M3×0.5	1.8	21	14	7	5.5	4.5	5	5	φ2.7 Counterbore φ4.8 Depth 9.5	6.5
CS-MBDAS10		34	10	24	4	17	M4×0.7	2.4	23	16	9	7	5.5	6	6	φ2.7 Counterbore φ4.8 Depth 10.5	7

# SENSOR SWITCHES

## Solid State Type



### Moving Sensor Switch

- Loosen the set screw, slide the sensor switch along the switch mounting groove on the Mini Bit Cylinder.
- Tighten the set screw with a tightening torque of 0.1N·m~0.2N·m [0.9 in·lbf~1.8 in·lbf]

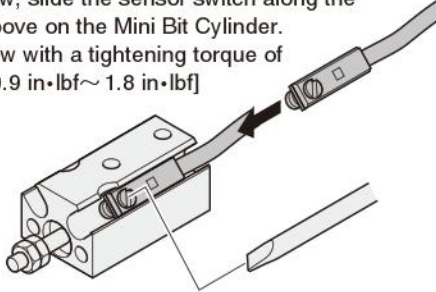

### When Mounting Sensor Switches in Close Proximity

If using the actuators in close proximity, use at the values shown in the table below, or larger.

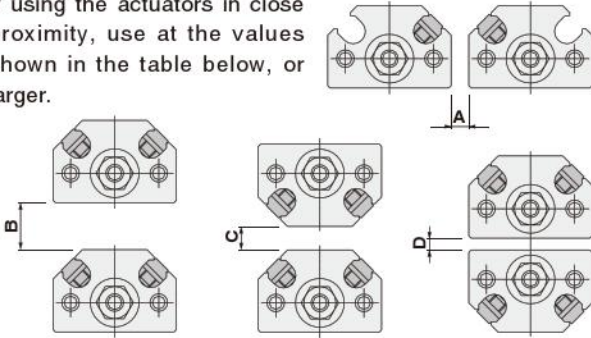

		mm [in.]			
Bore size	Item	A	B	C	D
4.5 [0.177]		2 [0.079]	6 [0.236]	1 [0.039]	2 [0.079]
6 [0.236]		4 [0.157]	9 [0.354]	5 [0.197]	3 [0.118]
8 [0.315]		3 [0.118]	8 [0.315]	4 [0.157]	2 [0.079]
10 [0.394]		2 [0.079]	8 [0.315]	4 [0.157]	1 [0.039]

### Minimum Cylinder Stroke When Using Sensor Switch

		mm [in.]			
Item	Bore size	4.5 [0.177]	6 [0.236]	8 [0.315]	10 [0.394]
Mounting 1 switch		1.5 [0.059]			
Mounting 2 switches		3 [0.118]			

### Mounting Location of Stroke End Detection Sensor Switch

If mounting a sensor switch in the positions shown in the diagram below (figures in the table are reference values), the magnet comes to the maximum sensing location of the sensor switch at the end of stroke.

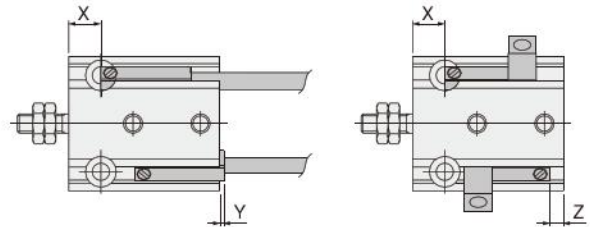

		mm [in.]			
Item	Bore size	4.5 [0.177]	6 [0.236]	8 [0.315]	10 [0.394]
Double acting type	X	6 [0.236]	5.5 [0.217]	5 [0.197]	5 [0.197]
	Y	1.5 [0.059]	1 [0.039]	1.5 [0.059]	1 [0.039]
	Z	2 [0.079]	2 [0.079]	2 [0.079]	2.5 [0.098]
Single acting push type	X	8 [0.315]	7.5 [0.295]	7 [0.276]	7 [0.276]
	Y	1.5 [0.059]	1 [0.039]	1.5 [0.059]	1 [0.039]
	Z	2 [0.079]	2 [0.079]	2 [0.079]	2.5 [0.098]
CS specifications	X	10 [0.394]	9.5 [0.374]	9 [0.354]	9 [0.354]
	Y	1.5 [0.059]	1 [0.039]	1.5 [0.059]	1 [0.039]
	Z	2 [0.079]	2 [0.079]	2 [0.079]	2.5 [0.098]

## Sensor Switch Operating Range, Response Differential, and Maximum Sensing Location

● **Operating range:**  $\ell$

The distance the piston travels in one direction, while the switch is in the ON position.

● **Response differential:** C

The distance between the point where the piston turns the switch ON and the point where the switch is turned OFF as the piston travels in the opposite direction.

● **Solid state type**

mm [in.]

Item \ Bore size	4.5 [0.177]	6 [0.236]	8 [0.315]	10 [0.394]
Operating range: $\ell$	1.6~2.8 [0.063~0.110]	1.8~3.0 [0.071~0.118]	1.8~3.0 [0.071~0.118]	2.0~3.2 [0.079~0.126]
Response differential: C	0.2 [0.008] or less			
Maximum sensing location <sup>Note</sup>	6 [0.236]			

Remark: The above table shows reference values.

Note: This is the length measured from the switch's opposite end side to the lead wire.

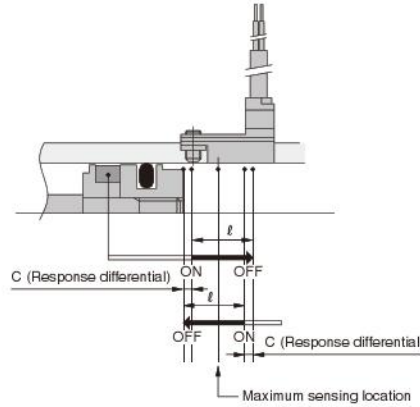

## Order Codes

