

KOGANEI

GENERAL CATALOG OF AIR TREATMENT, AUXILIARY, VACUUM

ELECTRO-PNEUMATIC TRANSDUCING REGULATORS INDEX

ELECTRO-PNEUMATIC TRANSDUCING REGULATORS

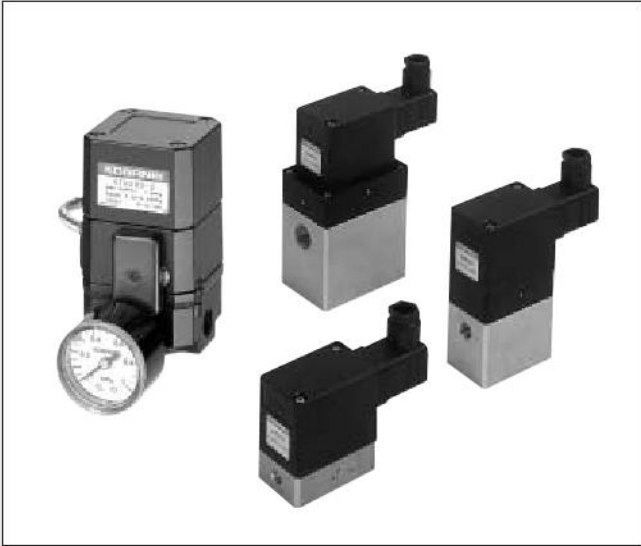

ETR Series

Features, Operating Principle	205
Application Example	206
Handling Instructions and Precautions	207
Input Signal and Secondary Pressure Characteristics	209
ETR010	210
ETR200	212
ETR600	214
ETR601	216

KTR Series

Features, Application Example	218
Handling Instructions and Precautions	219
Specifications, Order Code	221
Inner Construction	222
Dimensions	223

 **Caution** Before use, be sure to read the "Safety Precautions" on p. 31.

ELECTRO-PNEUMATIC TRANSDUCING REGULATORS

ETR Series

Electro-Pneumatic Transducing Regulators

A fusion of air and electronics

- Flexibly control pressure.
- A sequencer (PC) allows remote control operation.
- Feedback control ensures superior flow rate characteristics.

Body construction uses P.W.M. control poppet

- Simple construction. Not requiring special air quality.
- Non-bleed type means no air leak problems.
- Any mounting direction is acceptable. It can withstand strong shocks and vibrations.

Operating Principle of Electro-Pneumatic Transducing Regulators

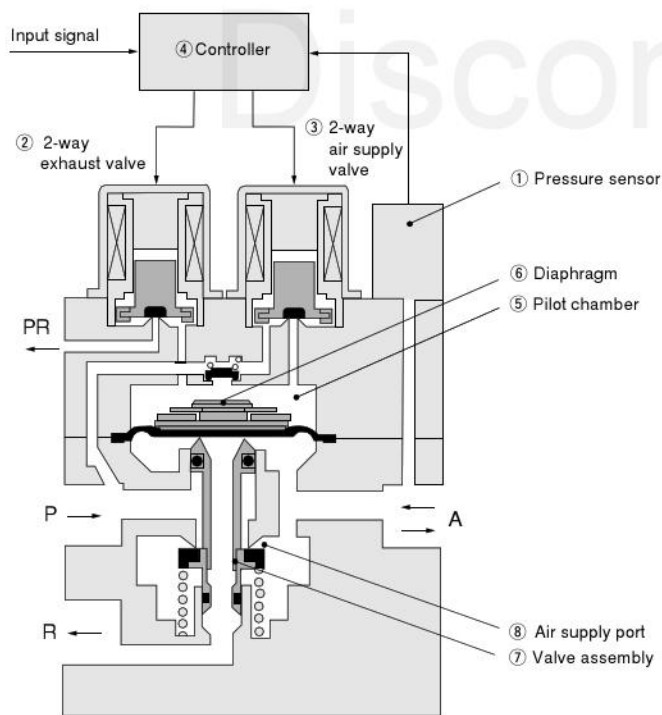

This illustration shows the ETR200.

Increasing output air pressure A

When the controller (4) input signal increases, the 2-way valve (3) is activated and pressure on the pilot chamber (5) rises. Then, forcing downward the diaphragm (6) causes the valve assembly (7) to move downward, opening the air supply port (8), and causing the supply pressure P to flow in and output air pressure A to rise. Pressure A is detected using the pressure sensor (1), and the feedback returns to the controller.

The 2-way valves (2), (3) respond to the difference between output air pressure A and set pressure by an input signal, and switch supply air on and off to perform pressure adjustment, to obtain an output air pressure A that is proportional to the input signal.

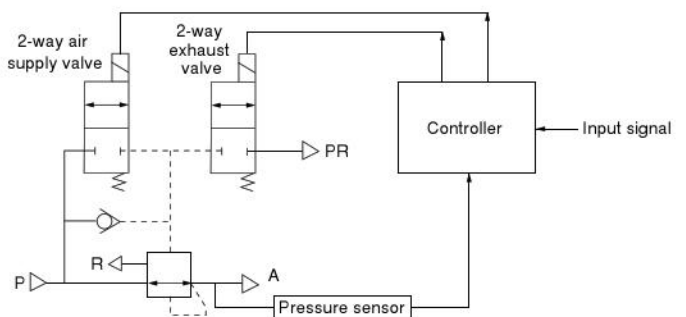

Block diagram

What is an electro-pneumatic transducing regulator?

A multi-purpose pressure control device that operates in response to voltage or current input signals from the outside to continuously step and accurately control high relief regulator's (pilot type) pilot section in electro-pneumatic transducers, for high-precision air pressure control.

Application Example of Electro-Pneumatic Transducing Regulator

The Koganei Electro-Pneumatic Transducing Regulator is optimum for such applications as:

- Level 1** Setting up simple test benches.
- Level 2** Multiple stepping of air cylinder thrust.
- Level 3** Controlling valves.
- Level 4** Controlling various types of flow dispensers.
- Level 5** Controlling tension force in winder equipment.

Level 1

- Automotive brake equipment
- Automotive electrical parts
- Various kinds of valve operations
- Research test labs

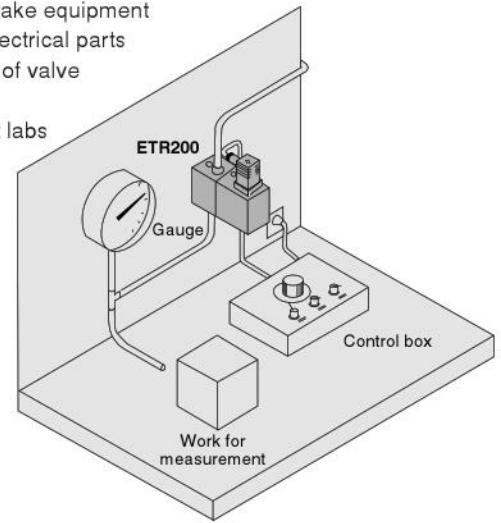

Level 2

- Automotive parts
- Wristwatch cases
- Print circuit board
- Various kinds of cutting

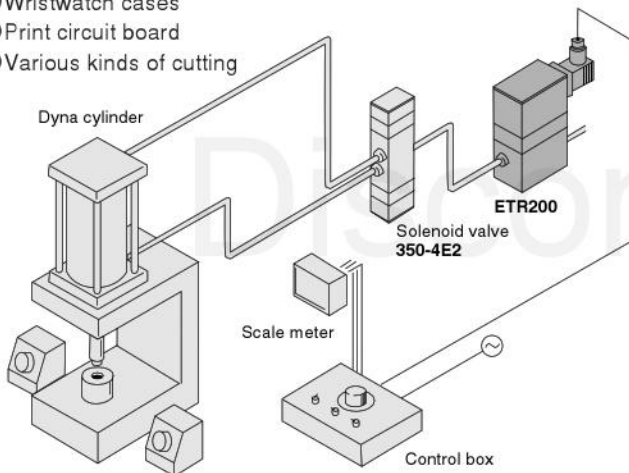

Level 3

- Bakeries and snacks food processing plants
- Pharmaceutical plants

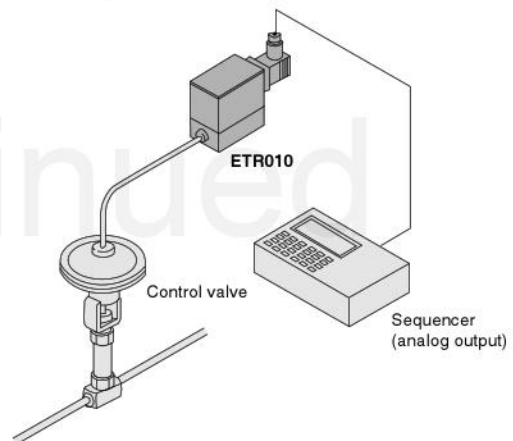

Level 4

- Laser disk manufacturing
- Applying solder paste
- Chemical filling machine

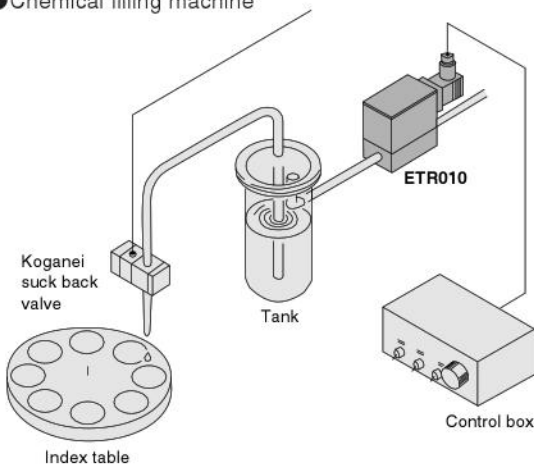

Level 5

- VTRs and other magnetic tape
- Coil wires
- Packaging material winding
- Electrical wiring material winding

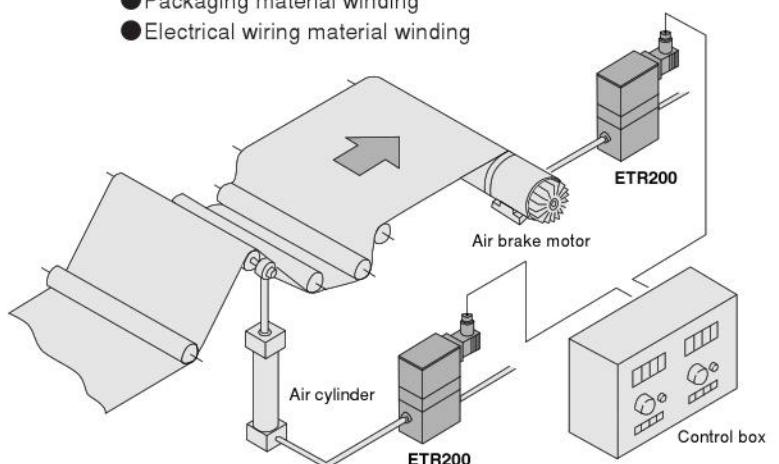

Remark: For other examples and technical information materials regarding the applications listed above, consult us.



Mounting and piping

1. Install in locations where wiring, piping, and maintenance work is easy to perform.
2. Do not leave the primary pressure applied when the electrical power has been switched OFF. (At this time, the secondary pressure could rise as high as the primary pressure.)
3. A bootstrap operation (of 1-2 seconds) occurs immediately after the power supply is switched ON, which could cause the secondary pressure to drop temporarily.
4. After switching ON the power supply, do not leave the primary pressure lower than the setting value.
5. Do not mount a valve on the primary side that will result in repeatedly switching the primary pressure ON and OFF.
6. Electric noise could result in operations instability. Always take adequate noise-reducing measures.
 - ※ For wiring, use shielded wiring.
 - ※ Use surge protection for nearby solenoid valves and inductive loads.
7. Mount in locations that are as distant from motors and powered lines as possible. When mounting near inductive loads and powered lines, always implement load surge suppression, and use magnetic shielding for insulation. In particular, consult us if planning to use in environments subject to much external electric noise.
8. The electro-pneumatic transducing regulator is adjusted to the specifications before being shipped out from Koganei. Avoid removing or disassembling any of its parts because such action could result in breakdowns.
9. For other handling issues, see the User's Manual included with the product.



General precautions

1. Always thoroughly blow off (use compressed air) the piping before plumbing. Entering chips, sealing tape, rust, etc., generated during piping work could result in air leaks or other defective operation.
2. As the interior of the electro-pneumatic transducing regulator uses precision parts, the compressed air should be cleaned air devoid of solid substances, moisture, etc. Intrusion of contaminated air into the device could have an adverse effect on operations characteristics and durability. For the use of any other media, consult us.
3. While the system can be used without lubrication, if lubricating the actuators, etc. is required, use Turbine Oil Class 1 (ISO VG32) or equivalent. Avoid using spindle oil or machine oil.
4. The product cannot be used when the media or the ambient atmosphere contains any of the substances listed below. Solvents, phosphate ester type hydraulic oil, sulphur dioxide, chlorine gas, or acids, etc.
5. If using in locations subject to dripping water or oil, etc., or to large amounts of dust, install a cover to protect the unit.

Wiring method

1. Removing the connector
 - (1) Loosen and remove the connector set-screw, and lift off the connector from the regulator.
 - (2) Loosen the tightening screw, remove the seal washer and seal, and push the body out from the cap.

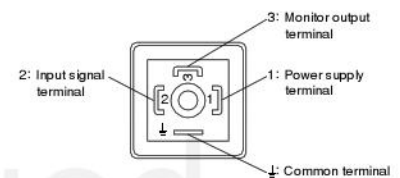
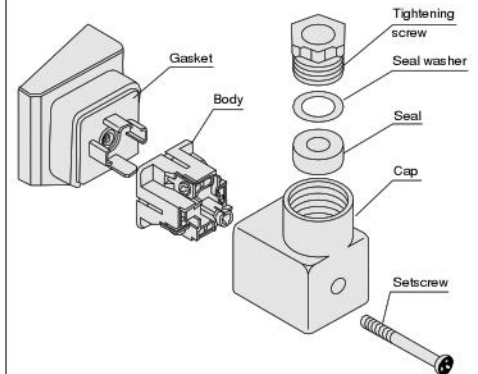

- 1.....Power supply+DC24V terminal
- 2.....Input signal terminal
 - Blank: DC 1~5 [V]
 - 1: DC 0~5 [V]
 - 2: DC 0~10 [V]
 - 4: DC 4~20 [mA]
- 3.....Monitor output terminal (DC1~5 [V])
- ⊥Common terminal (GND)

2. Wiring

- (1) To avoid erratic operation in the electro-pneumatic transducing regulator due to electric noise, divide the power supply, input signal, and monitor output lines each, and use shielded 2-wire cable for each.
- (2) The electro-pneumatic transducing regulator consumes a maximum of 5W of electrical power. For the power supply, therefore, use shielded wiring with a conductor area of 0.4mm²~0.5 mm² [0.0006~0.0008in²] (equivalent to AWG24~22).

Handling Instructions and Precautions



Recommendation

Peripheral pneumatic devices are available for use with the ETR series. See the following list for reference.

ETR010

Fitting	A, P port	TS6-01
		TS8-01
		TL6-01
		TL8-01
Muffler	R port	KM-1
		KM-11
Tube		U6-B (0)
		U8-B (0)
Filter		F150-01

ETR200

Fitting	A, P port	TS8-02
		TS10-02
		TL8-02
		TL10-02
Muffler	PR port	150-30A
	R port	KM-2
		KM-23
Tube		U8-B (0)
		U10-B (0)
Filter		F600-02

ETR600

Fitting	A, P port	TS10-04
		TS12-04
		TL10-04
		TL12-04
Muffler	PR port	150-30A
	R port	KM-4
		KM-41
Tube		U10-B (0)
		U12-B (0)
Filter		F600-04

ETR601

Fitting	A, P port	TS10-04
		TS12-04
		TL10-04
		TL12-04
Muffler	PR port	150-30A
	R port	KM-4
		KM-41
Tube		U10-B (0)
		U12-B (0)
Filter		F600-04

is continued

ETR010, 200, 600

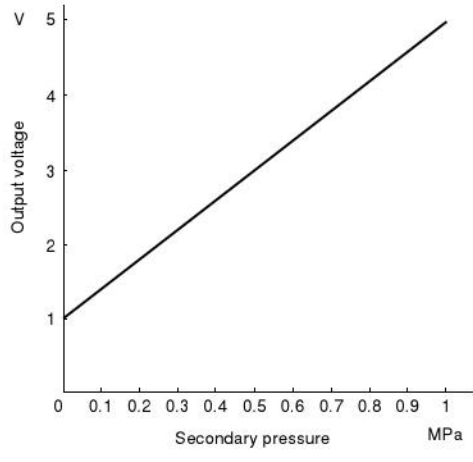
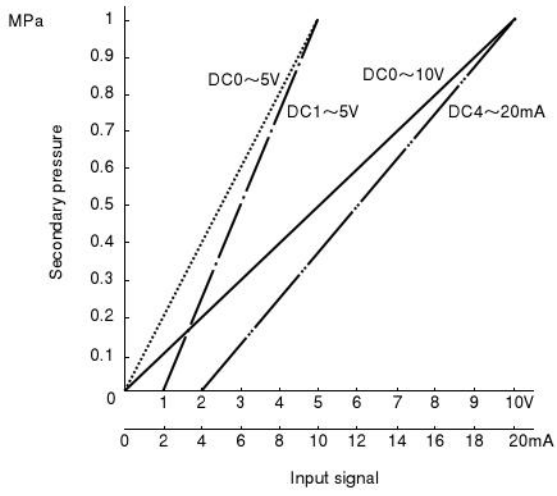

ETR601

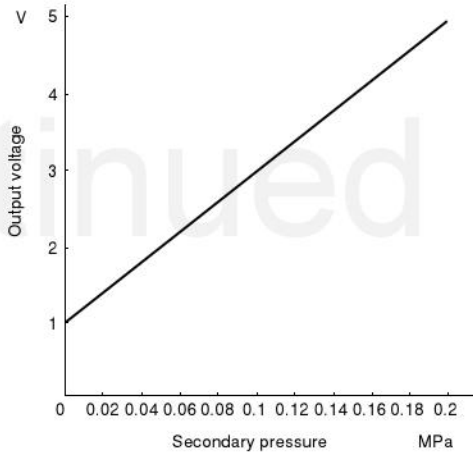
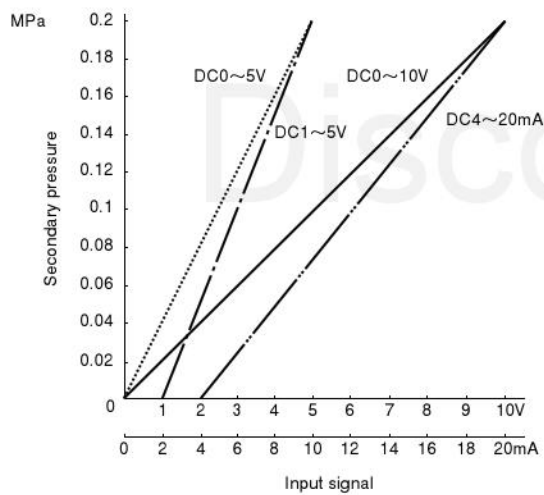

1MPa = 145psi.

ETR010



Specifications

Item		Basic model	ETR010	ETR010-1	ETR010-2	ETR010-4	
Media			Air				
Port size		Rc	1/8				
Setting pressure range		MPa(kgf/cm ²) [psi.]	0.005~0.7 {0.05~7.1} {0.7~102}				
Primary pressure range		MPa(kgf/cm ²) [psi.]	Set pressure or more, and 0.9 {9.2} {131} or less				
Proof pressure		MPa(kgf/cm ²) [psi.]	1.32 {13.5} {191}				
Input signal	Voltage control method	Voltage	DC[V]	1~5	0~5	0~10	—
		Input impedance	kΩ	20	20	42	—
	Current control method	Current	DC [mA]	—			4~20
		Input impedance	Ω	—			250
Output signal	Output voltage	DC [V]	1~5				
	Load impedance	kΩ	Min. 5				
Power supply		DC [V]	24 (7W)±10%				
Linearity*			±1.0% F.S.				
Hysteresis*			±0.5% F.S.				
Step response ^{Note}		s	Max. 1				
Operating temperature range (atmosphere and media)		°C [°F]	5~50 {41~122}				
Vibration resistance		m/s ² [ft/sec ²]{G}	Max. 98 {322} {9.99}				
Wiring			DIN connector (As standard)				
Mass		kg [lb]	0.44 {0.97}				

* Values are calculated assuming a pressure full span (F.S.) of 0.7MPa [102psi].
 Note: Secondary pressure values assume unloading conditions.

Symbol

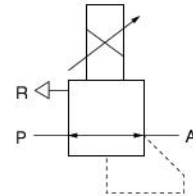

Order Code

Basic model	Input signal
ETR010	1 2 4

Mounting base is standard equipment.

- Blank — DC1~5(V)
- 1 — DC0~5(V)
- 2 — DC0~10(V)
- 4 — DC4~20(mA)

Flow Rate Characteristics and Relief Characteristics

ETR010

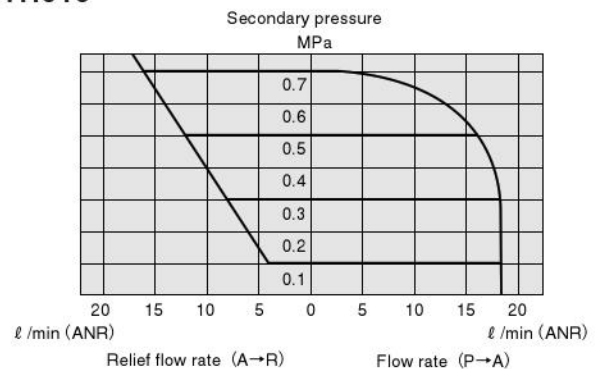

Remark: Primary pressure is 0.7MPa [102psi].
 1MPa = 145psi. 1 l/min = 0.0353 ft³/min

Inner Construction

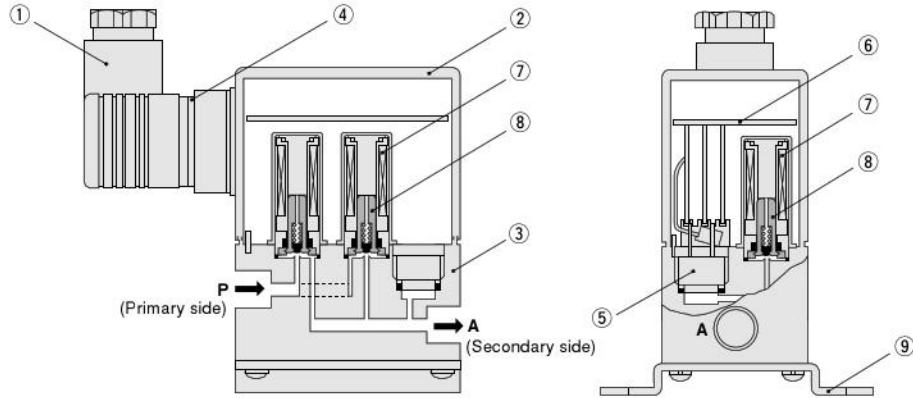

Major Parts and Materials

No.	Parts	Materials
①	DIN connector	Plastic
②	Cover	Plastic
③	Body	Aluminum alloy (anodized)
④	Gasket	Synthetic rubber (chloroprene)

No.	Parts	Materials
⑤	Pressure sensor	Plastic (diffusion-type semiconductor)
⑥	Circuit board assembly	Glass epoxy
⑦	Coil assembly	—
⑧	Plunger	Magnetic stainless
⑨	Mounting base	Mild steel (zinc plated)

Dimensions (mm)

ETR010

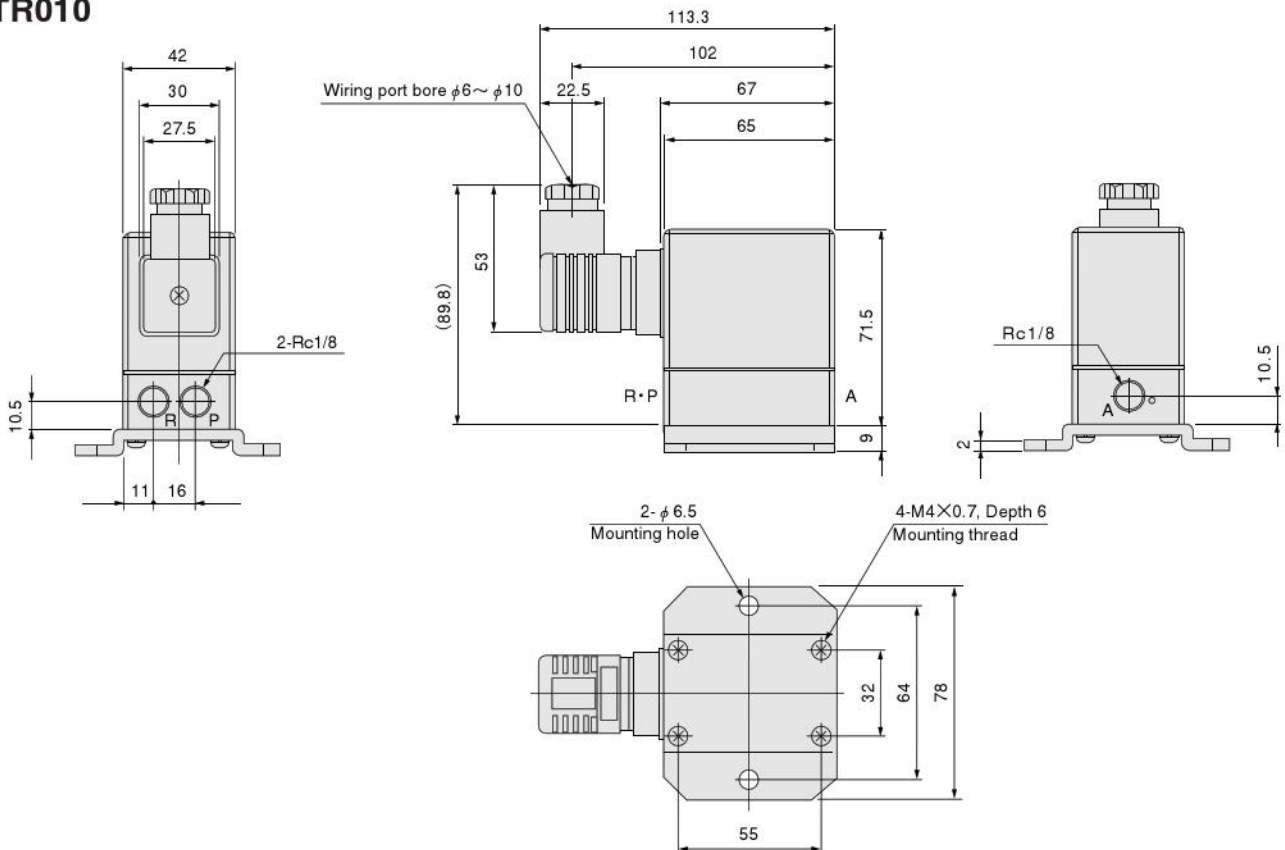

ETR200



Specifications

Symbol

Item		Basic model	ETR200	ETR200-1	ETR200-2	ETR200-4	
Media			Air				
Port size		Rc	1/4				
Setting pressure range		MPa {kgf/cm ² } [psi.]	0.01~0.7 {0.1~7.1} [1.5~131]				
Primary pressure range		MPa {kgf/cm ² } [psi.]	Set pressure +0.1 {1.0} [15] or more, and 0.9 {9.2} [131] or less				
Proof pressure		MPa {kgf/cm ² } [psi.]	1.32 {13.5} [191]				
Input signal	Voltage control method	Voltage	DC[V]	1~5	0~5	0~10	—
		Input impedance	kΩ	20	20	42	—
	Current control method	Current	DC [mA]	—			4~20
		Input impedance	Ω	—			250
Output signal	Output voltage	DC [V]	1~5				
	Load impedance	kΩ	Min. 5				
Power supply		DC [V]	24 (7W)±10%				
Linearity*			±1.0% F.S.				
Hysteresis*			±0.5% F.S.				
Step response ^{Note}		s	Max. 2				
Operating temperature range (atmosphere and media)		°C [°F]	5~50 [41~122]				
Vibration resistance		m/s ² [ft/sec ²] [G]	Max. 98 [322] [9.99]				
Wiring			DIN connector (As standard)				
Mass		kg [lb]	0.74 [1.63]				

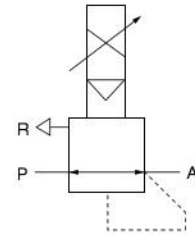

* Values are calculated assuming a pressure full span (F.S.) of 0.7MPa [102psi].
 Note: Secondary pressure values assume unloading conditions.

Order Code

Flow Rate Characteristics and Relief Characteristics

Basic model	Input signal
ETR200	1 2 4

Mounting base is standard equipment.

- Blank — DC1~5(V)
- 1 — DC0~5(V)
- 2 — DC0~10(V)
- 4 — DC4~20(mA)

ETR200

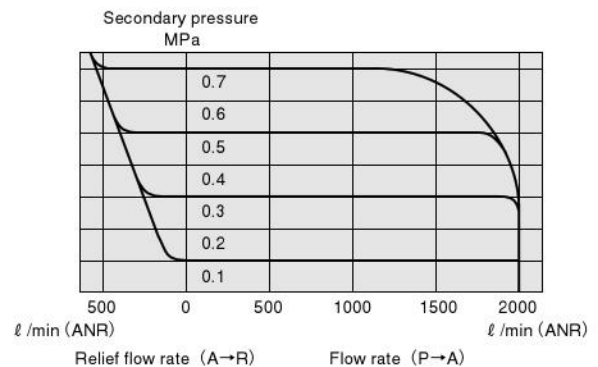

Remark: Primary pressure is 0.83MPa [120psi].
 1MPa = 145psi. 1 l/min = 0.0353 ft³/min

Inner Construction

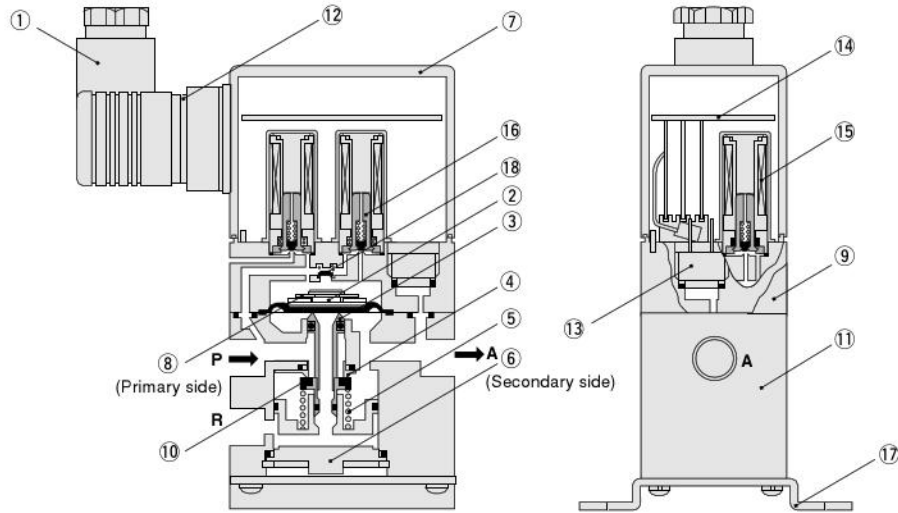

Major Parts and Materials

No.	Parts	Materials
①	DIN connector	Plastic
②	Diaphragm	Aluminum (NBR baked)
③	Valve pin	Brass
④	Valve seat	Brass
⑤	Spring	Piano wire
⑥	Exhaust cover	Aluminum alloy (anodized)
⑦	Cover	Plastic
⑧	Balancer	Brass
⑨	Adapter	Aluminum alloy (anodized)

No.	Parts	Materials
⑩	Valve	Brass (NBR baked)
⑪	Body	Aluminum alloy (anodized)
⑫	Gasket	Synthetic rubber (chloroprene)
⑬	Pressure sensor	Plastic (diffusion-type semiconductor)
⑭	Circuit board assembly	Glass epoxy
⑮	Coil assembly	—
⑯	Plunger	Magnetic stainless
⑰	Mounting base	Mild steel (zinc plated)
⑱	Check valve	Synthetic rubber (NBR)

Dimensions (mm)

ETR200

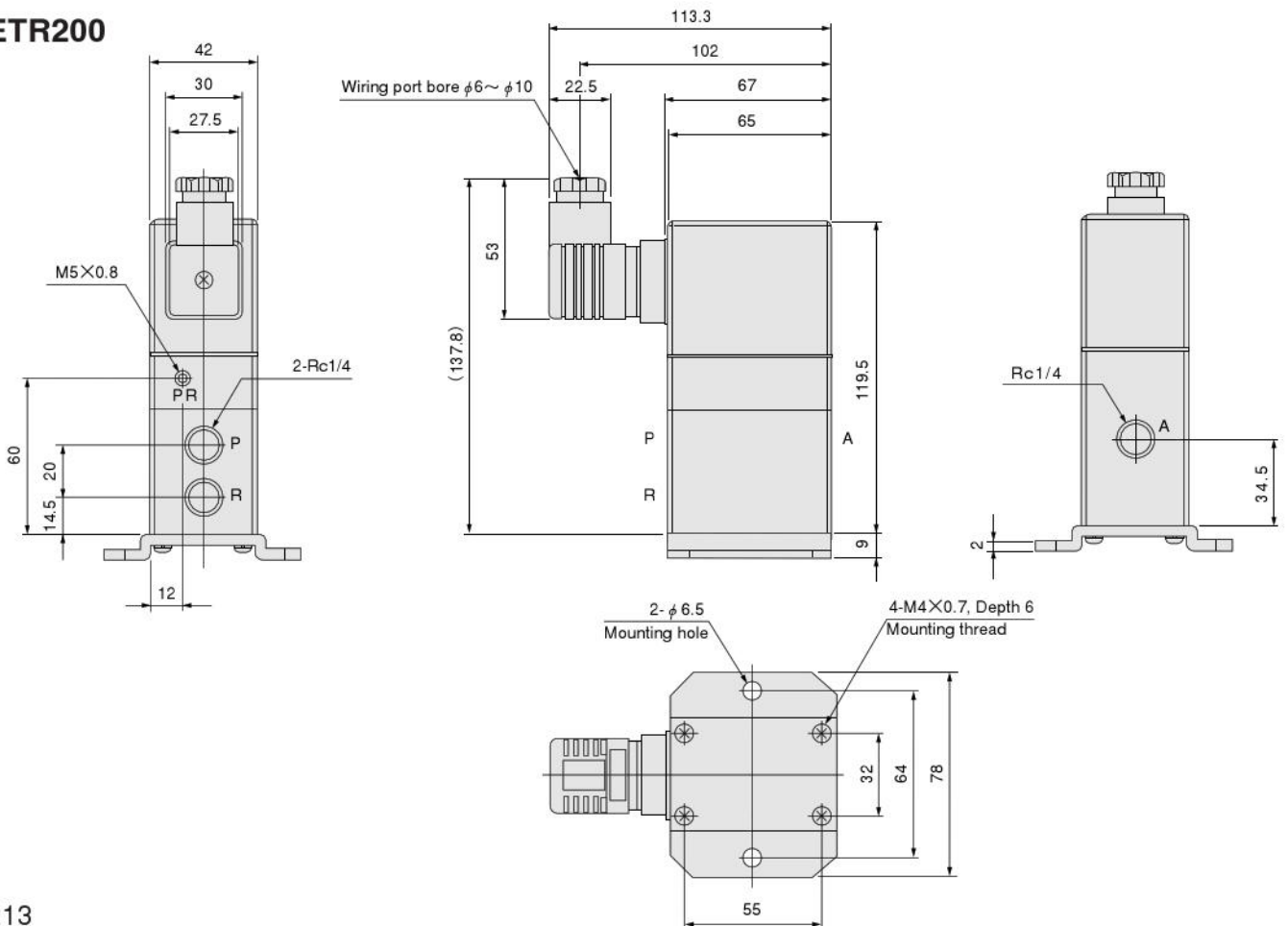

ETR600



Specifications

Symbol

Item		Basic model	ETR600	ETR600-1	ETR600-2	ETR600-4	
Media			Air				
Port size		Rc	1/2				
Setting pressure range		MPa {kgf/cm ² } [psi.]	0.01~0.7 {0.1~7.1} [1.5~102]				
Primary pressure range		MPa {kgf/cm ² } [psi.]	Set pressure +0.1 {1.0} [15] or more, and 0.9 {9.2} [131] or less				
Proof pressure		MPa {kgf/cm ² } [psi.]	1.32 {13.5} [191]				
Input signal	Voltage control method	Voltage	DC [V]	1~5	0~5	0~10	—
		Input impedance	kΩ	20	20	42	—
	Current control method	Current	DC [mA]	—			4~20
		Input impedance	Ω	—			250
Output signal	Output voltage	DC [V]	1~5				
	Load impedance	kΩ	Min. 5				
Power supply		DC [V]	24 (7W)±10%				
Linearity*			±1.0% F.S.				
Hysteresis*			±0.5% F.S.				
Step response ^{Note}		s	Max. 2				
Operating temperature range (atmosphere and media)		°C [°F]	5~50 [41~122]				
Vibration resistance		m/s ² [ft/sec ²] [G]	Max. 98 [322] [9.99]				
Wiring			DIN connector (As standard)				
Mass		kg [lb]	1.2 [2.65]				

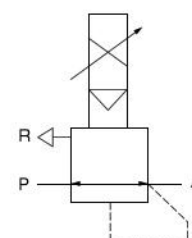

*: Values are calculated assuming a pressure full span (F.S.) of 0.7MPa [102psi].
Note: Secondary pressure values assume unloading conditions.

Order Code

Flow Rate Characteristics and Relief Characteristics

Basic model	Input signal
ETR600	1 2 4

Mounting base is standard equipment.

- Blank — DC1~5(V)
- 1 — DC0~5(V)
- 2 — DC0~10(V)
- 4 — DC4~20(mA)

ETR600

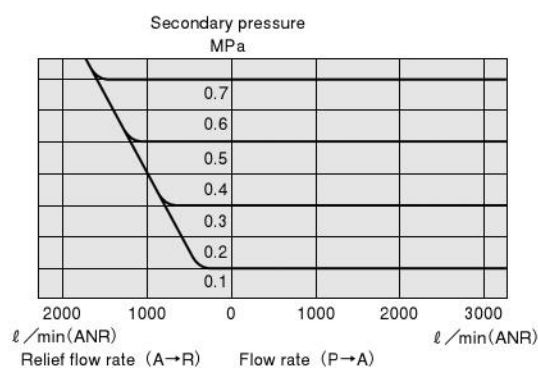

Remark: Primary pressure is 0.83MPa [120psi].
1MPa = 145psi. 1 l/min = 0.0353 ft³/min

ETR600

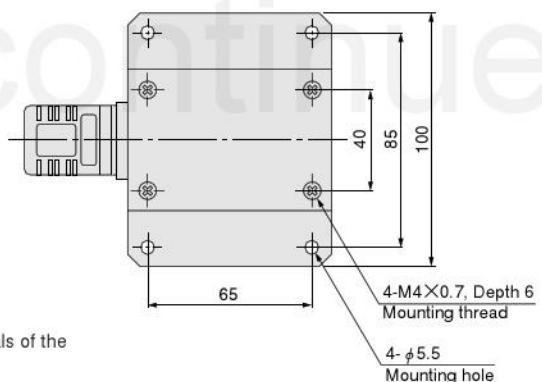
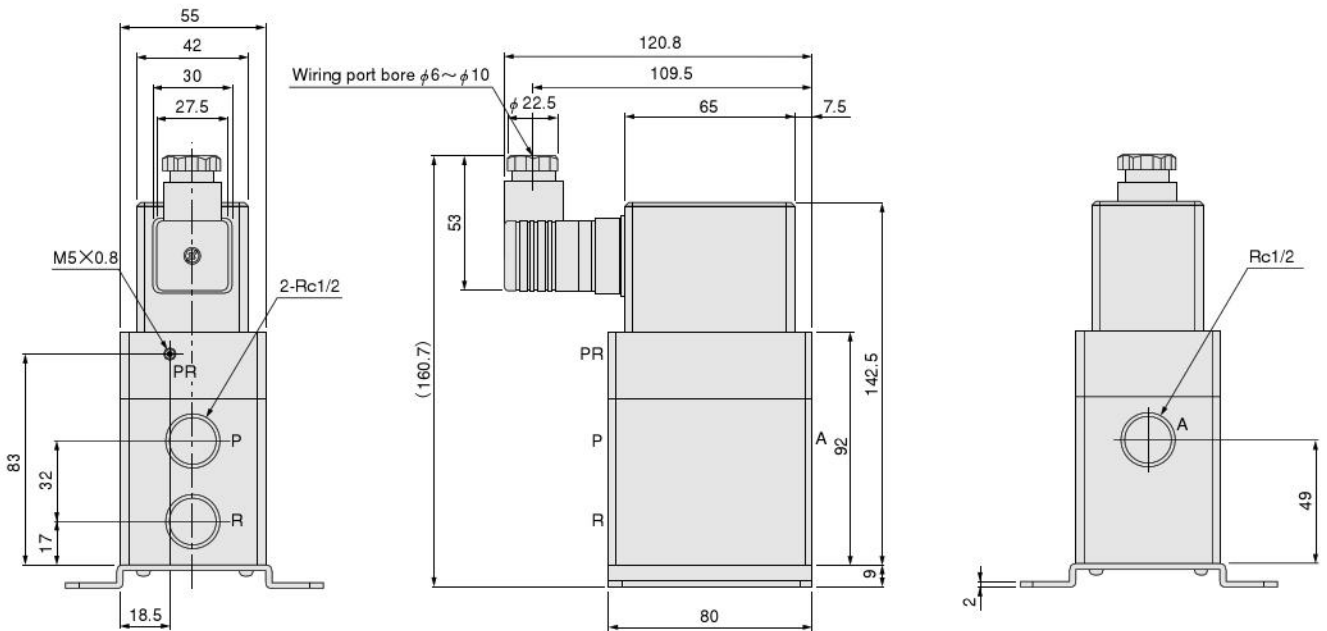

Remark: The inner construction and major parts and materials of the ETR600 are the same as the ETR200. See p.213.

ETR601



Specifications

Symbol

Item		Basic model	ETR601	ETR601-1	ETR601-2	ETR601-4
Media			Air			
Port size		Rc	1/2			
Setting pressure range		MPa {kgf/cm ² } [psi.]	0.01~0.2 {0.1~2.0} [1.5~29]			
Primary pressure range		MPa {kgf/cm ² } [psi.]	Set pressure +0.05 {0.5} [7] or more, and 0.4 {4.0} [58] or less			
Proof pressure		MPa {kgf/cm ² } [psi.]	0.6 {6.1} [87]			
Input signal	Voltage control method	Voltage DC [V]	1~5	0~5	0~10	—
		Input impedance kΩ	20	20	42	—
	Current control method	Current DC [mA]	—			4~20
		Input impedance Ω	—			250
Output signal	Output voltage DC [V]	1~5				
	Load impedance kΩ	Min. 5				
Power supply		DC [V]	24 (7W) ±10%			
Linearity*			±1.0% F.S.			
Hysteresis*			±0.5% F.S.			
Step response ^{Note}		s	Max. 2			
Operating temperature range (atmosphere and media)		°C [°F]	5~50 [41~122]			
Vibration resistance		m/s ² [ft/sec ²] [G]	Max. 98 [322] [9.99]			
Wiring			DIN connector (As standard)			
Mass		kg [lb]	1.2 [2.65]			

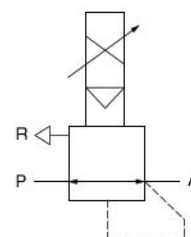

※ Values are calculated assuming a pressure full span (F.S.) of 0.2MPa [29psi].
 Note: Secondary pressure values assume unloading conditions.

Order Code

Basic model	Input signal
ETR601	1 2 4

Mounting base is standard equipment.

- Blank — DC1~5(V)
- 1 — DC0~5(V)
- 2 — DC0~10(V)
- 4 — DC4~20(mA)

Flow Rate Characteristics and Relief Characteristics

ETR601

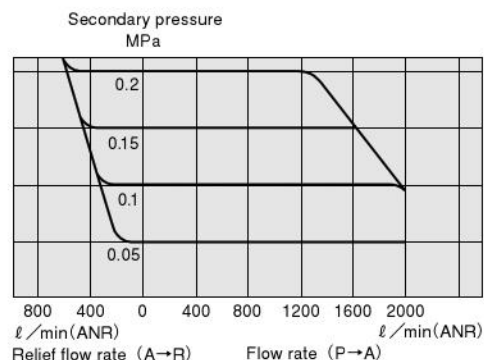

Remark: Primary pressure is 0.25MPa [36psi].
 1MPa = 145psi. 1 l/min = 0.0353 ft³/min

ETR601

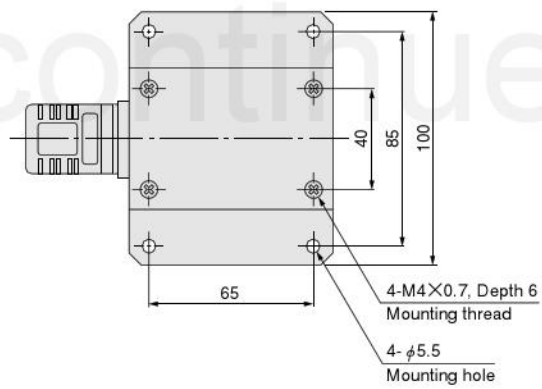
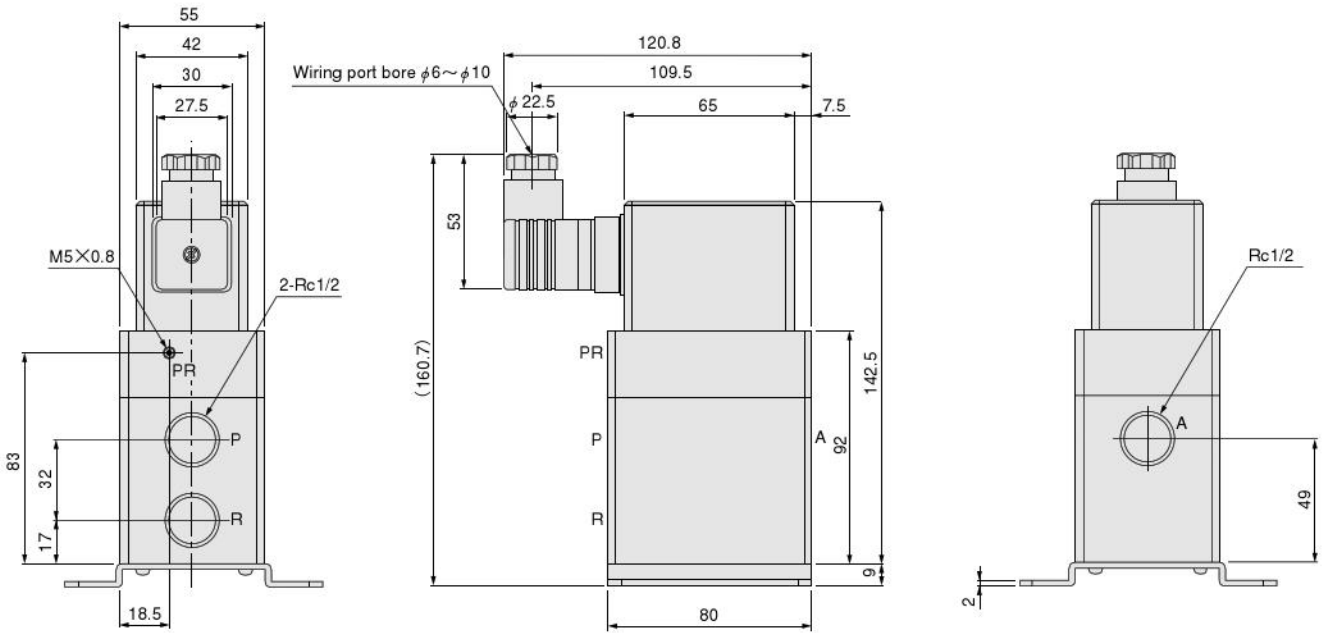

Remark: The inner construction and major parts and materials of the ETR601 are the same as the ETR200. See p.213.

ELECTRO-PNEUMATIC TRANSDUCING REGULATORS

KTR Series

Electro-Pneumatic Transducing Regulators



- Offer high-precision pressure control.
- Excellent pressure and flow rate characteristics.
- Any mounting direction is acceptable.
(adjustment is required, however)
- Lightweight, compact unit occupies little space.

Discontinued

Application example

Equipment applications: Printing equipment, paper plant equipment, plastic film processing equipment, textile machinery, grinders and polishers, etc.

① Tension control

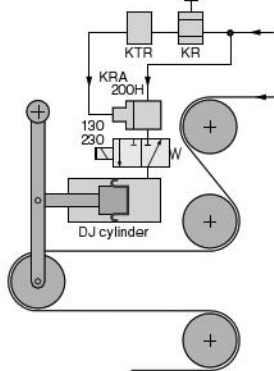

② Pressure control (grinders)

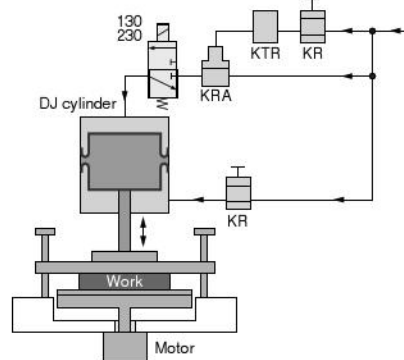

Handling Instructions and Precautions



General precautions

1. Do not install a valve on the primary side that will result in repeatedly switching the primary pressure ON and OFF.
2. Always thoroughly blow off (use compressed air) the piping before connecting to electro-pneumatic transducing regulators.
3. Use air for the media. For the use of any other media, consult us. In addition, the media constantly bleeds to the outside. Use with proper understanding of the structural characteristics.
4. Remove as much solid substances, moisture, oil, etc., as possible from the air supplied to the electro-pneumatic transducing regulator. In addition, avoid using the lubricator in locations in front of or behind the precision regulator.
5. Do not apply excessive external force on the product.



Mounting and piping

1. IN and OUT are indicated on the bottom of the body. Make the piping connections so as to conform with these instructions. While the piping port with no IN or OUT display is a gauge port, it also can be used as an OUT port. Be careful to use the proper connection, since reversing the IN and OUT connection ports could result in damage to the electro-pneumatic transducing regulator and to the pressure gauge.
2. When screwing in piping or fittings to the electro-pneumatic transducing regulator, tighten to the appropriate tightening torque shown below.

Connecting screw	Tightening torque N·m {kgf·m} [ft·lbf]
Rc1/4	11.6~13.4 {1.18~1.37} [8.56~9.88]
3. Using a wrench to mount a pressure gauge, always apply it to the squared section on the pressure gauge's piping connection port.
4. If mounting the electro-pneumatic transducing regulator as a single unit, use a bracket.
5. While any mounting direction is acceptable, use positioning that ensures easy access for zero point and span adjustment operations.
6. Mount in locations that are free of vibrations.

Maintenance

If output pressure fails to rise after signals have been sent to the unit, it may mean that the orifice (KTR200: ϕ 0.2 [0.008in.], KTR201: ϕ 0.5 [0.02in.]) is clogged. Remove the orifice and pass a pin through it to clean out the clogging.

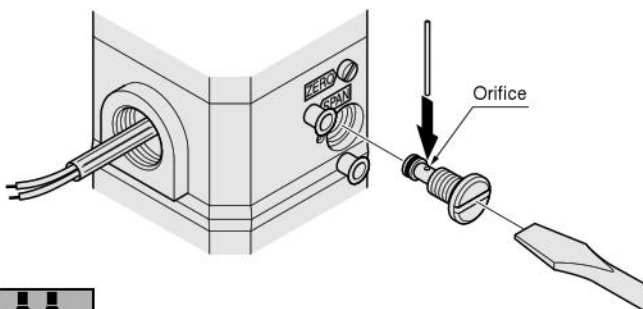

Wiring

Connect wiring in conformance with the table below. Ensure that the wiring connections are sufficiently distant from inductive loads (solenoid valves, motors, relays, etc.) and powered lines.

Electro-pneumatic transducing regulators	Polarity of signal	
	Normal operation ^{Note 1}	Reverse operation ^{Note 2}
Red lead wire	+	-
White lead wire	-	+

Notes: 1. Increasing the signal causes the output pressure to increase.
2. Increasing the signal causes the output pressure to decrease.



Pressure regulation and calibration

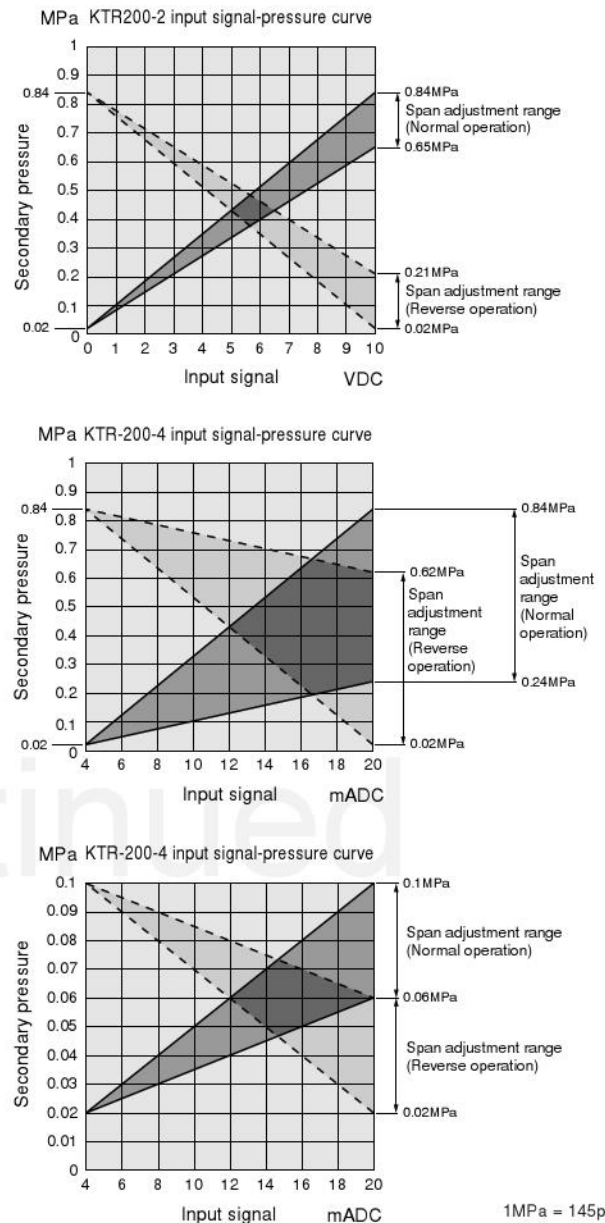

In the electro-pneumatic transducing regulator, the mounting conditions can cause shifts in the zero point and span adjustment values. Use the following sequence to calibrate the values.

1. Use a Phillips-type screwdriver to remove the cover of the electro-pneumatic transducing regulator.

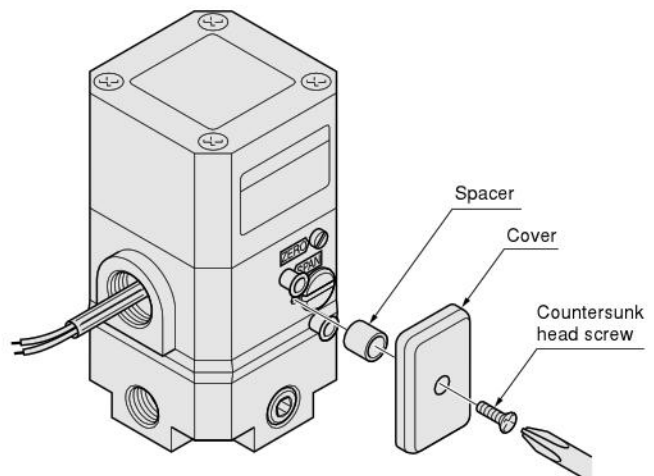

2. Set the input signals as shown in the table below.

Model	Input signal
KTR200-2	0 [VDC]
KTR20□-4	4 [mA DC]

3. Check that the output pressure is at 0.02MPa {0.2kgf/cm²} [3psi.]. If not at this value, use a screwdriver to set the lower limit with the zero point adjusting screw (for reverse operations, set the upper limit).

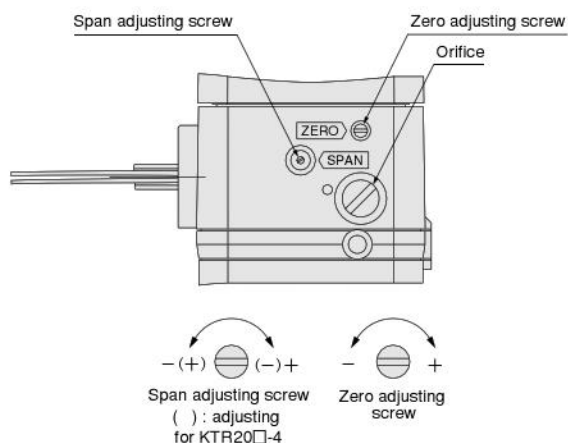

- ※ Always monitor the pressure gauge while slowly turning the zero point adjusting screw. Turning the screw farther than absolutely necessary could result in damage to the nozzle, leading to breakdowns.

4. Set the input signals as shown in the table below.

Model	Input signal
KTR200-2	10 [VDC]
KTR20□-4	20 [mA DC]

5. Use a small screwdriver to set the upper limit with the span adjusting screw (for reverse operations, set the lower limit).
 6. Repeat the operation step 2~5, until the upper and lower limits are determined.
 7. When calibration is complete, use a countersunk head screw with cross hole to remount the cover. The tightening torque for the countersunk head screw should be 0.5N · m {0.05kgf · m} [0.37ft · lbf].

ELECTRO-PNEUMATIC TRANSDUCING REGULATORS

KTR Series

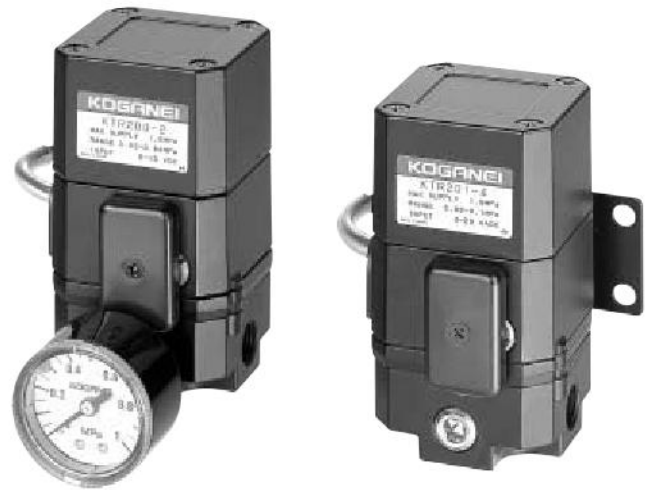

Symbol

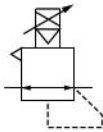

Specifications

Model		KTR200-2	KTR200-4	KTR201-4
Media		Air		
Port size	Rc	1/4		
Pressure setting range	Note MPa {kgf/cm ² } [psi.]	0.02~0.84 {0.2~8.6} [3~122]		0.02~0.1 {0.2~1.0} [3~15]
Primary pressure range	MPa {kgf/cm ² } [psi.]	1.0 {10.2} [145] MAX., Set pressure+0.035 {0.36} [5.1]		0.7 {7.1} [102] MAX., Set pressure+0.02 {0.2} [3]
Proof pressure	MPa {kgf/cm ² } [psi.]	1.5 {15.3} [218]		
Input signal	Control method	Voltage 2-lead wires		Current 2-lead wires
	Voltage	VDC	0~10	—
	Current	mADC	—	4~20
	Impedance	Ω	805	260
Linearity	% F.S.	1.5		1.0
Hysteresis	% F.S.	1.0		—
Repeatability	% F.S.	0.1		0.5
Step response	s	Max. 1.0		Max. 0.2
Span adjusting lower limit	MPa {kgf/cm ² } [psi.]	0.65 {6.6} [94]	0.24 {2.4} [35]	—
Relief sensitivity	MPa {kgf/cm ² } [psi.]	Set pressure+0.001 {0.01} [0.15]		
Air consumption	ℓ /min [ft ³ /min] (ANR)	Max. 3.7 [0.13]		Max. 4.8 [0.17]
Operating temperature range	°C [°F]	5~60 [41~140]		
Lubrication		Prohibited		
Pressure gauge connection port size	Rc	1/4		
Bracket		As standard		
Mass	kg [lb]	0.94 [2.07]		

Note: Pressure settings cannot be made in the range of 0 to 0.02 MPa {0~0.2kgf/cm²} [3psi.].

Order Code

KTR [] - [] - []

Electro-pneumatic transducing regulators
KTR series

Body model

200 : Standard specifications (0.84MPa [122psi.] specification)
201 : Low pressure specifications (0.1MPa [15psi.] specification)

Input signal

2 : 0~10VDC ^{Note 1}
4 : 4~20mADC

Pressure gauge specifications

Blank : Without pressure gauge
G1 : With pressure gauge (1MPa) [145psi.] ^{Note 1 Note 3}
G3 : With pressure gauge (0.3MPa) [44psi.] ^{Note 2 Note 3}

Notes: 1. Not available for KTR201.
2. Not available for KTR200.
3. For pressure gauge specifications and dimensions, see p. 154.

Pressure Characteristics

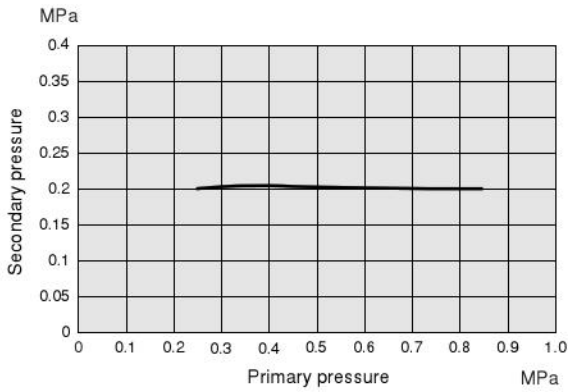

Flow Rate Characteristics

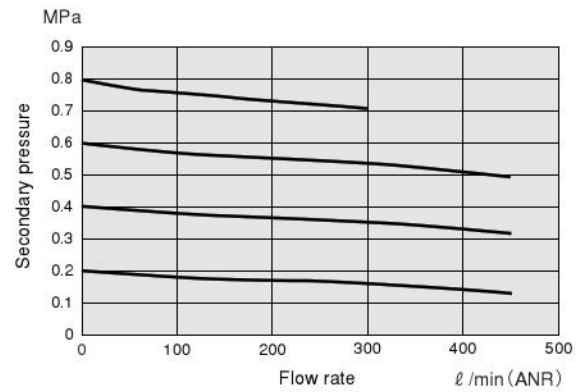

1MPa = 145psi. 1 l/min = 0.0353 ft³/min

Inner Construction

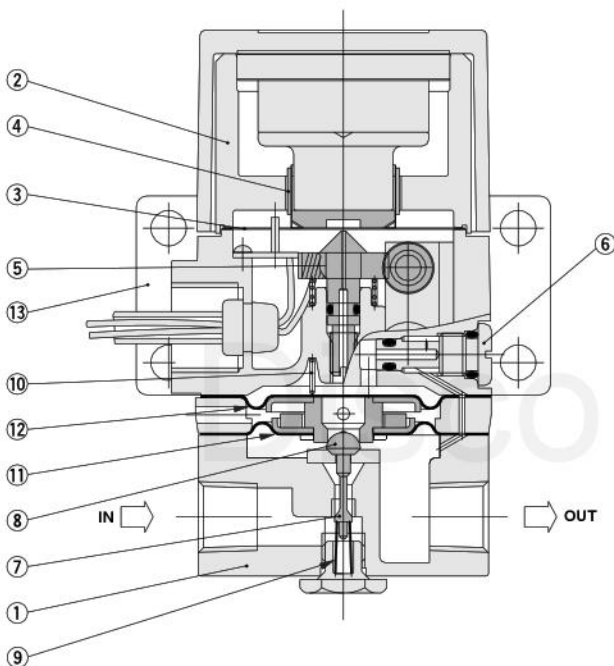

Major Parts and Materials

No.	Parts	Materials
①	Body	Aluminum alloy die-casting
②	Magnet	Alnico
③	Flapper	Beryllium copper
④	Moving coil	Urethane wire
⑤	Nozzle	Brass
⑥	Orifice	Brass
⑦	Main valve	Stainless steel
⑧	Exhaust valve	Stainless steel
⑨	Main valve spring	Stainless steel wire for spring
⑩	Diaphragm spring	Stainless steel wire for spring
⑪	Control diaphragm	Synthetic rubber (NBR) with layer cloth
⑫	Pilot diaphragm	Synthetic rubber (NBR) with layer cloth
⑬	Bracket	Rolled steel plate

Operating Principles

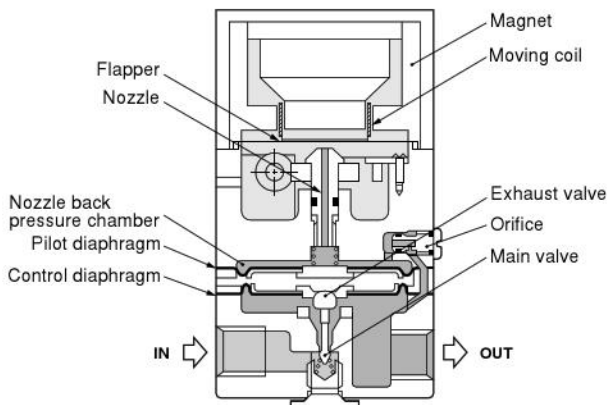

- Increasing the input signal causes the coil output to rise, pushing down the flapper, reducing the distance between the flapper and the nozzle, and increasing the back pressure of the nozzle. This action causes the pilot pressure to rise, opening the main valve and causing the secondary pressure to rise. The rise in secondary pressure stops and stabilizes at the point where the coil output comes into balance with the sum of nozzle back pressure and flapper reaction force. The above operation can be used to generate air pressure on the secondary side in proportion to the size of the electrical signal.

Dimensions (mm)

●KTR

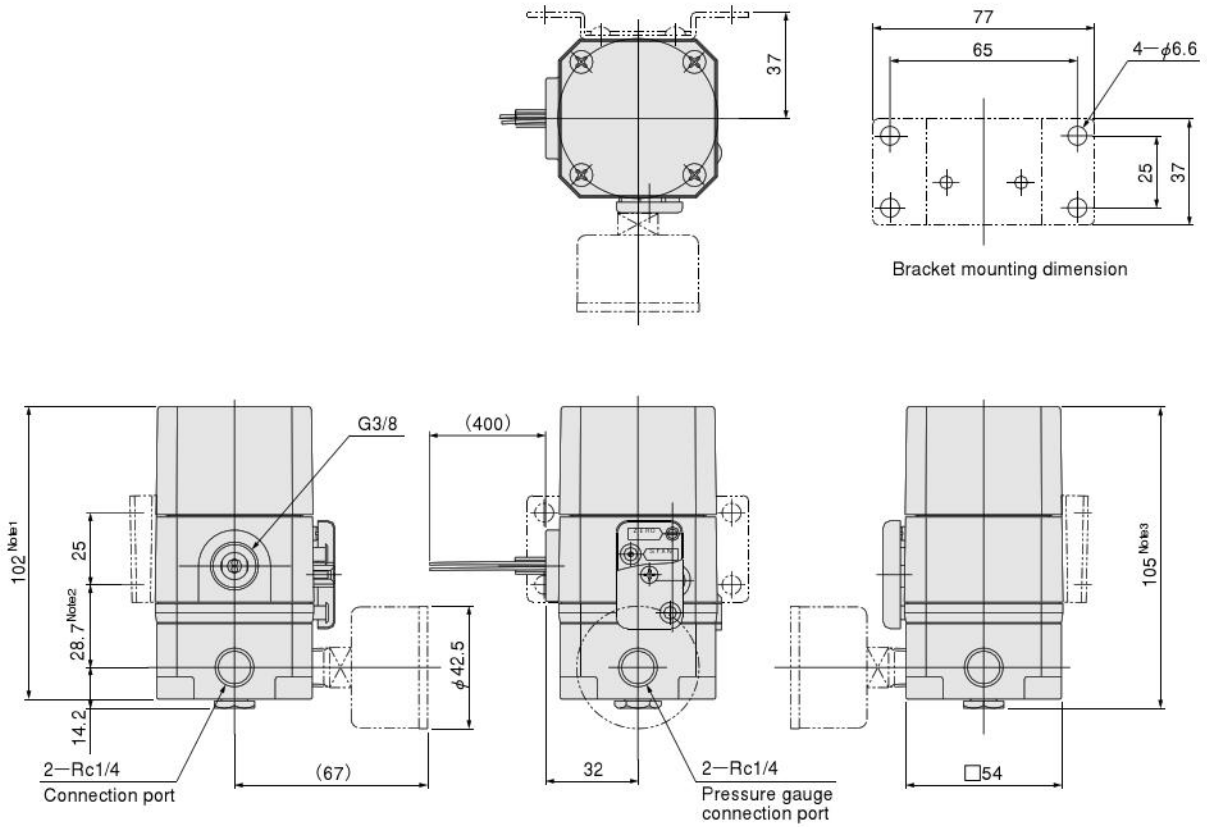

*KTR201-4 dimensions differ at the points shown in Notes 1~3.

Note 1 : 102.5

2 : 29.2

3 : 105.5

Discontinued

Dimensions of Pressure Gauge (mm)

G1-40, G3-40

