

Linear Orifice® Shock Absorber Series

NEW

KSHY Series Side load resistant Linear Orifice® Shock Absorber



- ! No need for an angle of eccentricity adaptor
- ! Each size can withstand up to 10°
- ! Maximum of more than 2 million operation cycles!

* Specifications in inches are not available.



KSHP Series

Adjustment Type Shock Absorber

- Shortened takt time
- Uses NSF certified H1 oil (non silicon)
- Maximum of more than 3million operation cycles!

KSHJ Series

Fixed type Shock Absorber

- 18 sizes and 132 models
- Supports a wide variety of impact masses
- Maximum of more than 2million operation cycles!
(800,000 operation cycles for M30 and higher)

KSHC Series

Clean Room Specification Shock Absorber

- Low dust emissions and Class 5 equivalent (FED-STD Class 100 equivalent)
- Non silicon
- Maximum of more than 2million operation cycles!

The KSHY series eliminates concerns about absorbing shocks from rotating loads!

Side load resistant Linear Orifice®

Shock Absorber **NEW** KSHY Series

* "Linear Orifice" is a registered trademark of Koganei Corporation.
* Specifications in inches are not available.

New release of our linear orifice models for shock absorbers with side load resistant!

This shock absorber lineup consists of 7 thread sizes from M6 to M20

Maximum of more than 2 million operation cycles!

The unique linear orifice structure, which is used in many applications, provides a long service life

Cap can also be selected as an option

Compliant with H1 grade food equipment specifications!

Uses NSF H1 grade oil (non silicon).

Contributes to space saving!

Integrated a main unit and a side load bearing.
Can be used without an adaptor to handle rotary side load!

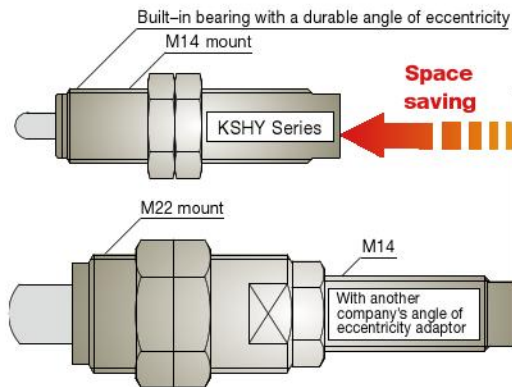

* Illustration

Since you do not need an adaptor, you can also save space with the mounting unit (screw hole)!

Spherically machined



With cap

Wide range of variations

M6 to M20

7 sizes 132 models



With cap



KSHY6×4 KSHY8×5 KSHY10×6 KSHY12×6 KSHY14×8 KSHY16×8 KSHY20×10

KSHP series can solve the problems for users worried about fine tuning absorption of impacts!

Introducing **the KSHP Series** of **Adjustment Type Linear Orifice® Shock Absorber**

* "Linear Orifice" is a registered trademark of Koganei Corporation.

New release of our first adjustment type linear orifice models!

Shorten operation cycle times by adjusting the absorbing capacity of the end of strokes.

Possible to fine tune for both impact speed and load for proper shock absorption!

Our own construction makes fine tuning easy and minimizes extreme changes in shock absorbing capacity.

Maximum of more than 3 million operation cycles!

Linear orifice construction provides longer life.

* "M24" model 8 hundred thousand operation cycles.

Compliant with H1 grade food equipment specifications!

Uses NSF H1 grade oil (non silicon).

Scaled from 0 to 6

Numbers are easy to see and indelible

Set to 6 on the scale for maximum absorption
Set to 0 on the scale for minimum absorption

Adjusting knob

Can be rotated to the left or right

Red mark

Align the red mark to a value on the scale

Lock screw

Lock the adjusting knob in position by tightening the lock screw after completing adjustment (excluding KSHP6 and KSHP8)

Scaled from 0 to 6 (adjusting knob)

Set to 6 on the scale for maximum absorption
Set to 0 on the scale for minimum absorption

Key slot on body

Align a value on the scale to the key slot



For KSHP6 and KSHP8

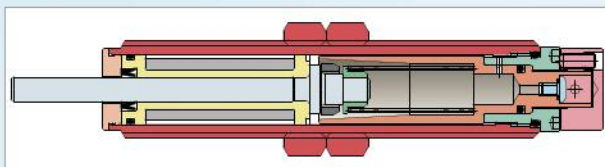

Wide range of variations

M6 to M42

12 sizes 13 models

Wide range of variations

1/4-32 UNEF to 1 3/4-12UN

11 sizes 29 models



KSHP6×4 KSHP8×6 KSHP10×8 KSHP12×10 KSHP14×12 KSHP16×15 KSHP18×20 KSHP20×22 KSHP25×25 KSHP30×30 KSHP36×50 KSHP42×50

Shock absorbers designed by pneumatic cylinder engineers

Linear Orifice® Shock Absorber KSHJ Series (fixed type)



A wealth of variations
with sizes from M4 to M48
18 sizes and **132** models

A wealth of variations
with sizes from
10-32UNF to 1 3/4-12UN
12 sizes and **92** models



Supports a wide variety of impact masses
Supports a wide range of impacting objects, from grams (g) with the M4 size to tons (t) with the M48 size.

Supports a wide variety of impact speeds
Supports maximum impact speeds of 0.8 m/s to 3 m/s.

Stopper nut not needed
Workpieces directly contact the end of the body, so there is no need for mounting a stopper nut. Mounting is easy and saves space.

Body is entirely threaded
Entire body is threaded to maximize the range of installation positions and also improve heat dissipation.
Note: Except for M4 and M6 (10-32UNF, 1/4-32UNEF) sizes.



Supports high cycle times

Reduces the time from impact to end of operation. Even if the workpiece mass and speed changes, our original linear orifice construction automatically adjusts to prevent wasted operation time. Combined with reduced vibration, this contributes to improved productivity.

Silent design

Reducing the impact value at collision decreases the noise at workpiece impact.

Short stroke type

Perfect in low speed range for shock absorbing in limited spaces.

Long stroke type

Making the absorbing stroke longer allows for softer absorption of shocks.

short stroke type (with hexagon socket)!

Overall length reduced for shock absorbing in tight locations!



Up to 26% reduction in overall length compared to the same standard threaded body type (for M20). Excellent for absorbing shocks in tight locations as a stopper between 2 cylinder stroke ends because overall short length. Fine position adjustments are easy with more models available with hex sockets.



List of KSHJ body thread sizes

[Specifications in mm]

Size	Model			Body thread size × pitch	
	Short stroke	Standard	Long stroke		
M4	—	KSHJ4 × 3	—	M4 × 0.5	—
M6	—	KSHJ6 × 4	KSHJ6 × 6	M6 × 0.75	—
M8	KSHJ8 × 4	KSHJ8 × 5	KSHJ8 × 8	M8 × 0.75	M8 × 1
M10	KSHJ10 × 6	KSHJ10 × 10	KSHJ10 × 15	M10 × 1	—
M12	KSHJ12 × 6	KSHJ12 × 10	—	M12 × 1	—
M14	KSHJ14 × 8	KSHJ14 × 12	—	M14 × 1.5	—
M16	KSHJ16 × 8	KSHJ16 × 15	—	M16 × 1.5	—
M18	—	KSHJ18 × 16	—	M18 × 1.5	—
M20	KSHJ20 × 10	KSHJ20 × 16	—	M20 × 1.5	—
M22	—	KSHJ22 × 25	—	M22 × 1.5	—
M25	—	KSHJ25 × 25	—	M25 × 1.5	M25 × 2
M27	—	KSHJ27 × 25	—	M27 × 1.5	M27 × 3
M30	—	KSHJ30 × 30	—	M30 × 1.5	—
M33	—	KSHJ33 × 30	—	M33 × 1.5	—
M36	—	KSHJ36 × 50	—	M36 × 1.5	—
M42	—	KSHJ42 × 50	KSHJ42 × 70	M42 × 1.5	—
M45	—	KSHJ45 × 50	—	M45 × 1.5	—
M48	—	KSHJ48 × 50	—	M48 × 2	—

[Specifications in inches]

Size	Model		
	Short stroke	Standard	Long stroke
10-32 UNF	—	KSHJ4 × 3-F11	—
1/4-32 UNEF	—	KSHJ6 × 4-F11	KSHJ6 × 6-F11
5/16-32 UNEF	KSHJ8 × 4-F11	KSHJ8 × 5-F11	KSHJ8 × 8-F11
3/8-32 UNEF	KSHJ10 × 6-F11	KSHJ10 × 10-F11	KSHJ10 × 15-F11
7/16-28 UNEF	KSHJ11 × 6-F11	KSHJ11 × 10-F11	KSHJ11 × 15-F11
1/2-20 UNF	KSHJ12 × 6-F11	KSHJ12 × 10-F11	—
9/16-18 UNF	KSHJ14 × 8-F11	KSHJ14 × 12-F11	—
3/4-16 UNF	—	KSHJ18 × 16-F11	—
1-12 UNF	—	KSHJ25 × 25-F11	—
1 1/4-12 UNF	—	KSHJ30 × 30-F11	—
1 3/8-12 UNF	—	KSHJ36 × 50-F11	—
1 3/4-12 UN	KSHJ42 × 50-F11	KSHJ42 × 70-F11	—

Low dust emissions

Softened shocks

Silicone-free

Shock Absorbers with Clean Specifications

Linear orifice type KSHC series (fixed type)

* "Linear Orifice" is a registered trademark of Koganei Corporation.

Low dust emissions

Capable of JIS/ISO Class 5 equivalent cleanliness (FED-STD Class 100 equivalent) calculated within a 0.1 μm particle. (Koganei standard)^{Note 1}

A particle pocket structure is used to prevent the scattering of dust.

Note 1: Refer to page 59 for the Koganei standard.

Note 2: Packaged in single layer packaging.

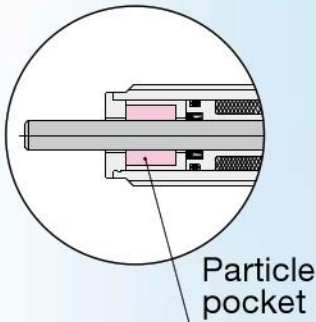

Softened shocks

These shock absorbers achieve their smooth shock absorption characteristics thanks to the linear orifice structure. Reduces vibrations and shocks to bases and equipment.

Silicone-free

Silicone is not used in the hydraulic oil or plastic.

Wide range of variations
M4 to M25
 9 sizes and 40 models

Wide range of variations
10-32 UNF to 1-12 UNF
 9 sizes and 36 models

Linear orifices' long service life and softened shocks

These shock absorbers achieve their smooth shock absorption characteristics and a long service life thanks to the linear orifice structure that transforms the orifice linearly.

Since the linear orifice structure can increase the inner diameter of the shock absorbers without needing an inner tube, the shock absorbers demonstrate similar characteristics to shock absorbers one thread size larger, as well as reduce the vibrations and shocks to bases and equipment.

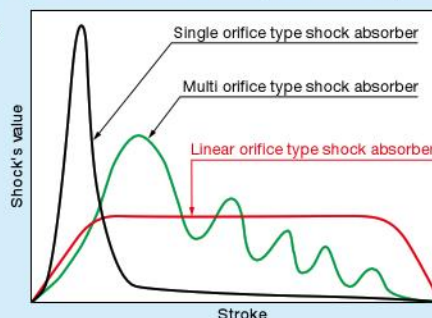
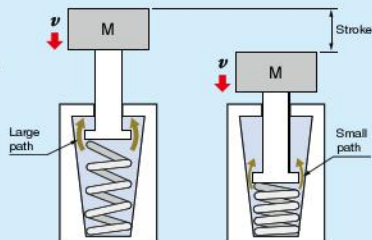

Principles of operation

The piston stroke squeezes the oil's flow path steplessly to softly absorb shocks.





List of linear orifice shock absorber products

[Specifications in mm]





Size	Basic mounting type	Durable angle of eccentricity	Adjustable type	Clean specification	Options		
	KSHJ	KSHY	KSHP	KSHC	Cap	Stopper nut	Side mount
M4 × 0.5	●			●	 Plastic cap		
M6 × 0.75	●	●	●	●			
M8 × 0.75	●	●	●	●			
M8 × 1	●	●	●	●			
M10 × 1	●	●	●	●			
M12 × 1	●	●	●	●			
M14 × 1.5	●	●	●	●			
M16 × 1.5	●	●	●	●			
M18 × 1.5	●		●	●			
M20 × 1.5	●	●	●	●			
M22 × 1.5	●		●	●			
M25 × 1.5	●		●	●			
M25 × 2	●						
M27 × 1.5	●						
M27 × 3	●						
M30 × 1.5	●		●				
M33 × 1.5	●						
M36 × 1.5	●		●				
M42 × 1.5	●		●				
M45 × 1.5	●						
M48 × 2	●						

[Specifications in inches]

Size	Basic mounting type	Adjustable type	Clean specification	Options			
	KSHJ	KSHP	KSHC	Cap	Stopper nut		
10-32 UNF	●		●	 Plastic cap			
1/4-32 UNEF	●	●	●				
5/16-32 UNEF	●	●	●				
3/8-32 UNEF	●	●	●				
7/16-28 UNEF	●	●	●				
1/2-20 UNF	●	●	●				
9/16-18 UNF	●	●	●				
3/4-16 UNF	●	●	●				
1-12 UNF	●	●	●				
1 1/4-12 UNF	●	●					
1 3/8-12 UNF	●	●					
1 3/4-12 UN	●	●					
						 Rubber cap * Only for KSHP 12 to 42	

Before selecting and using the products, please read all the "Safety Precautions" carefully to ensure proper product use. The Safety Precautions described below are to help you use the product safely and correctly, and to prevent injury or damage to you, other people, and assets. Be sure to observe these safety precautions together with the following safety regulations of ISO4414 (Pneumatic fluid power - General rules and safety requirements for systems and their components), and JIS B 8370 (General rules relating to systems).

The directions are ranked according to degree of potential danger or damage: "DANGER", "WARNING", "CAUTION" and "ATTENTION."

 DANGER	Indicates situations that can be clearly predicted as dangerous. Death or serious injury may result if the situation is not avoided. It could also result in damage or destruction of assets.
 WARNING	Indicates situations that, while not immediately dangerous, could become dangerous. Death or serious injury may result if the situation is not avoided. It could also result in damage or destruction of assets.
 CAUTION	Indicates situations that, while not immediately dangerous, could become dangerous. Failure to avoid the situation creates the risk of minor or semi-serious injury. It could also result in damage or destruction of assets.
 ATTENTION	It could also result in damage or destruction of assets. appropriate use of the product.

■ This product was designed and manufactured for use in general industrial machinery.

- When selecting and handling equipment, the system designer or another person with sufficient knowledge and experience should always read the "Safety Precautions", "catalog", "instruction manual", and other literature before commencing operation. Improper handling is dangerous.
- After reading the instruction manual, catalog, and other documentation, always place them in a location that allows easy availability for reference to users of this product.
- Whenever transferring or lending the product to another person, always attach the catalog, instruction manual, and other information to the product where they are easily visible in order to ensure that the new user can use the product safely and properly.
- The danger, warning and caution items listed under these "Safety Precautions" do not cover all possible contingencies. Read the catalog and instruction manual carefully, and always keep safety first.

DANGER

- Do not use the product for the purposes listed below:
 1. Medical equipment related to maintenance or management of human lives or bodies.
 2. Machines or equipment designed for the purpose of moving or transporting people.
 3. Critical safety components in mechanical devices.
 This product has not been planned or designed for purposes that require high levels of safety. Using the product in any of the ways described above creates the risk of loss of human life.
- Do not use the product in locations with or near dangerous substances such as flammable or ignitable substances. This product is not explosion-proof. It could ignite or burst into flames.
- When mounting the product and workpiece, always make sure they are firmly supported and secured in place. Ensure the mounting material is strong enough. If the product falls over, is dropped, or breaks, it may result in injury.
- Never attempt to modify the product in any way. Doing so can cause an abnormal operation and create the risk of injury, etc.
- Never attempt inappropriate disassembly, assembly or repair of the product relating to basic construction, or to its performance or to functions. This can lead to injury, etc.
- Do not splash water on the product. Spraying it with water, washing it, or using it under water could result in malfunction leading to injury, etc.
- While the product is in operation, avoid touching it with your hands or otherwise approaching too close. Also, do not mount shock absorbers or make adjustments while the equipment is in operation. The equipment may move suddenly, possibly resulting in injury.

WARNING

- Do not use the product in excess of its specification range. Doing so creates the risk of product breakdown, loss of function, or damage. It could also drastically reduce operating life.
- The small screw on the back end of the shock absorber should never be loosened or removed. Oil may leak out of the shock absorber leading to a loss of functionality and resulting in injury.
- When conducting any kind of operation for the product, such as maintenance, inspection, repair, or replacement, always turn off the air supply and power to the equipment and make sure that the equipment is completely stopped.
- When mounting the product, always follow the handling instructions and precautions. Also when mounting the product, before operation, check that the mounting nut is tightened and not loose and then operate the product. If the mounting nut is loose, etc., this will result in damage to the equipment and accidents.
- Do not allow the product to be thrown into fire. The product could explode, ignite, and/or release toxic gases.

- Do not apply a load to the product, or place other objects on it. It could lead to damaged or broken products that result in degraded performance, function stops, etc.
- If the product has not been used for over 30 days, it is possible that the contacting parts may have become stuck, leading to abnormal operation at impact. Check for proper operation a minimum of once every 30 days.
- Do not use the product at the beach in direct sunlight, near mercury lamps, or near equipment that generates ozone. Ozone causes rubber components to deteriorate resulting in reduced performance, or a limitation or stop of functions.

CAUTION

- Do not use in locations that are subject to direct sunlight (ultraviolet rays); locations with high humidity and temperature, dust, salt, or iron powder; or in locations with fluids and/or ambient atmosphere that include organic solvents, phosphate ester type hydraulic oil, sulfur dioxide, chlorine gas, acids, etc. It could lead to early shutdown of some functions, a sudden degradation of performance, and a reduced operating life. For information about materials, see Major Parts and Materials.
- When installing the product, be sure to allow adequate work space around it. Failure to do so will make it more difficult to conduct daily inspections or maintenance, which could eventually lead to system shutdown or damage to the product.
- When transporting or mounting a heavy product, firmly support the product using a lift or support, or use multiple people to ensure personal safety. Also, wear protective gloves and use safety shoes etc. for protection as necessary.
- Always post an "operations in progress" sign for installations, adjustments, or other operations, to avoid unintentional supplying of air or electrical power, etc. Unintentional supplying of air or electrical power can cause the equipment to operate and may result in injury.
- Never apply lubrication to the product sliding parts. This leads to changes in the physical properties and deterioration of the materials used, resulting in reduced functionality.
- Attempting to use the shock absorber with a cap over the specification range could result in damage to the cap or to its flying off and causing personal injury. Moreover, if cracks or fractures appear in the cap, replace it as quickly as possible.
- Always wash your hands thoroughly after touching the oil or grease used on the shock absorber. There is a danger that the grease or oil from your hands will get on the cigarette and burn, releasing toxic gases, as you smoke the cigarette.
- As a means to prevent vibration, do not use the product at a high frequency that exceeds the value in the catalog. It could drastically reduce the product's operating life.
- When using the shock absorber, gradually increase the speed of the impact object. Suddenly increasing the speed when using the shock absorber may damage the device or injure someone.

 ATTENTION

- Whenever considering use of this product in situations or environments not specifically noted in the catalog or instruction manual, or in applications where safety is an important requirement such as in aircraft equipment, combustion equipment, leisure equipment, safety equipment, and other places where human life or assets may be greatly affected, take adequate safety precautions such as allowing plenty of margin for ratings and performance, or fail-safe measures. Contact the sales department of Koganei regarding use in such applications.
- When the product can no longer be used, or is no longer necessary, dispose of it appropriately, according to the "Law Regarding the Disposal and Cleaning of Waste" or other local governmental rules and regulations, as industrial waste. Incinerating the special oil in the KSHC series (clean specification) or the KSHJ series (short stroke type) generates hazardous fluorine (HF), which is corrosive and toxic. Because of this, incineration must be done in an incinerator that has neutralizing equipment that can handle acids. For large amounts, ask a registered waste disposal company.
- The product can exhibit degraded performance and function over its operating life. Always conduct daily inspections and confirm that all requisite system functions are satisfied, to prevent accidents from happening.
- When handling the product, wear protective gloves, safety glasses, safety shoes, and other protective clothing.
- The maximum absorption in the specifications are for a normal temperature (20 to 25°C [68 to 77°F]). Be aware that performance and characteristics change depending on the operating temperature.
- The shock absorber's absorption capacity changes depending on the speed of the impacting object. Use the product within the ranges of the selection graphs.
- For inquiries about the product, consult your nearest Koganei sales office or Koganei Overseas Department. The addresses and telephone numbers are shown on the back cover of this catalog.

 Other

- Always observe the following items.
 1. When using this product in a system, use only genuine Koganei parts or equivalent (recommended) parts. When conducting maintenance and repairs, always use genuine Koganei parts or compatible parts (recommended parts). Always observe the prescribed methods and procedures.
 2. Never attempt unauthorized disassembly or assembly of the product relating to its basic construction, its performance, or its functions.

Koganei shall not be held responsible for any problems that occur as a result of these items not being properly observed.

Warranty and General Disclaimer

1. Warranty Period

Koganei warrants this product for a period of no more than 1 year from delivery.

* However, some products have a 2-year warranty; contact your nearest Koganei sales office or the Koganei Technical Service Center for details.
2. Scope of Warranty and General Disclaimer
 - (1) When a product purchased from Koganei or from an authorized Koganei distributor malfunctions during the warranty period in a way that is found to be attributable to Koganei responsibility, Koganei will repair or replace the product free of charge. Even if a product is still within the warranty period, its durability is determined by its operation cycles and other factors. Contact your nearest Koganei sales office or the Koganei overseas department for details.
 - (2) The Koganei product warranty covers only the product itself. Therefore, Koganei is not responsible for incidental losses (repair of the product, various expenses required for replacement, etc.) caused by breakdown, loss of function, or loss of performance of Koganei products.
 - (3) Koganei shall not be held responsible for any losses or for any damage to other machinery caused by breakdown, loss of function, or loss of performance of Koganei products.
 - (4) Koganei shall not be held responsible for any losses due to use or storage of the product in a way that is outside of the product specifications prescribed in Koganei catalogs and the instruction manual, and/or due to actions that violate the mounting, installation, adjustment, maintenance and other safety precautions.
 - (5) Koganei shall not be held responsible for any losses caused by breakdown of the product due to factors outside the responsibility of Koganei, including but not limited to fire, natural disaster, the actions of third parties, and intentional actions or errors by you.

INDEX



Linear Orifice®
Shock Absorber

KSHJ Series

10 page ▶▶▶

Durable Angle of Eccentricity
Linear Orifice®
Shock Absorbers

KSHY Series

34 page ▶▶▶



Adjustment Type
Linear Orifice®
Shock Absorber

KSHP Series

46 page ▶▶▶

Shock Absorbers with Clean
Specifications

KSHC Series

60 page ▶▶▶

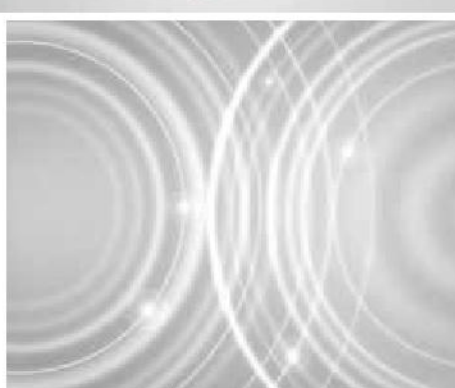

Additional Parts

72 page ▶▶▶

Linear Orifice® Shock Absorbers

KSHJ Series



KSHJ

KSHY

KSHP

KSHC

Additional Parts

Handling instructions and precautions



General precautions

Cover the unit when mounting it in locations where it might be subject to excessive dust, dripping water, dripping oil, etc. Dents, scratches, water, oil, or dust on the piston rod results in damage and decreases service life.



Mounting

1. Keep the angle of eccentricity, resulting from the load direction and the axis of the shock absorber, under the specified values on pages 17 to 19. If an eccentric load exceeding the specifications is applied, it could result in breakage or impaired returns. If there is concern that an eccentric load exceeding the specified values will be applied, install a guide, or similar mechanism.
2. Two or more shock absorbers can be mounted in parallel, to boost absorption capacity. In such an arrangement, however, be careful to ensure that the load is evenly distributed to each shock absorber.
3. To adjust the capacity with the stroke, adjust the stopper nut (-S) or add an external stopper.
4. If using with a cap, always mount a stopper nut (-S) or an external stopper to ensure that the cap is not subjected to loads at the stroke end. The stopper nut mounting position must not exceed the distance shown in the table below. You can use it without a stopper nut or external stopper, but over the long-term, the stop location changes due to cap deformation and wear.

Model	A	
	mm	in
KSHJ4 × 3C-01,-02 (-F11)	3	0.12
KSHJ6 × 4C-01,-02 (-F11)	4	0.16
KSHJ6 × 6C-01,-02 (-F11)	6	0.24
KSHJ8 × 4C-01,-02,-11,-12 (-F11)	4	0.16
KSHJ8 × 5C-01,-11 (-F11)	5	0.20
KSHJ8 × 8C-01,-02,-11,-12 (-F11)	8	0.31
KSHJ10 × 6C-01,-02 (-F11)	6	0.24
KSHJ11 × 6C-F11-01,-02	—	0.24
KSHJ10 × 10C-01,-02 (-F11)	10	0.40
KSHJ11 × 10C-F11-01,-02	—	0.40
KSHJ10 × 15C-01,-03 (-F11)	15	0.60
KSHJ11 × 15C-F11-01,-03	—	0.60
KSHJ12 × 6C-01,02 (-F11)	6	0.24
KSHJ12 × 10C-01,-02 (-F11)	10	0.40
KSHJ14 × 8C-01,02 (-F11)	8	0.31
KSHJ14 × 12C-01,-02 (-F11)	12	0.47
KSHJ16 × 8C-01,-02	8	—
KSHJ16 × 15C-01,-02	15	—
KSHJ18 × 16C-01,-02 (-F11)	16	0.63
KSHJ20 × 10C-01,-02	10	—
KSHJ20 × 16C-01,-02	16	—
KSHJ22 × 25C-01,-02	25	—
KSHJ25 × 25C-01,-11,-12 (-F11)	25	0.98
KSHJ27 × 25C-01,-02,-11,-12	25	—
KSHJ30 × 30C-01,-02,-03 (-F11)	30	1.18
KSHJ33 × 30C-01,-02,-03	30	—
KSHJ36 × 50C-01,-02,-03 (-F11)	50	1.97
KSHJ42 × 50C-01,-02 (-F11)	50	1.97
KSHJ42 × 70C-01,-02 (-F11)	70	2.76
KSHJ45 × 50C-01,-02	50	—
KSHJ48 × 50C-01,-02	50	—

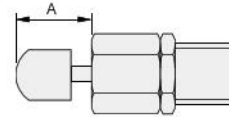

5. The small screw on the back end of the shock absorber should never be loosened or removed. Oil may leak out of the shock absorber leading to a loss of functionality and resulting in damage to the equipment and accidents.
6. When mounting the shock absorber, always use the following maximum tightening torque guidelines. Tightening using excessive force may result in damage.

Model	Maximum tightening torque	
	N · m	in · lbf
KSHJ4 × 3 (C)-01,-02 (-F11)	0.5	4.43
KSHJ6 × 4 (C)-01,-02 (-F11)	0.85	7.52
KSHJ6 × 6 (C)-01,-02 (-F11)	0.85	7.52
KSHJ8 × 4 (C)-01,-02,-11,-12 (-F11)	2.5	22.12
KSHJ8 × 5 (C)-01,-11 (-F11)	2.5	22.12
KSHJ8 × 8 (C)-01,-02,-11,-12 (-F11)	2.5	22.12
KSHJ10 × 6 (C)-01,-02 (-F11)	6.5	57.53
KSHJ11 × 6 (C)-01,-02	—	57.5
KSHJ10 × 10 (C)-01,-02 (-F11)	6.5	57.53
KSHJ11 × 10 (C)-01,-02	—	57.5
KSHJ10 × 15 (C)-01,-03 (-F11)	6.5	57.53
KSHJ11 × 15 (C)-01,-03	—	57.5
KSHJ12 × 6 (C)-01,02 (-F11)	8.0	70.80
KSHJ12 × 10 (C)-01,-02 (-F11)	8.0	70.80
KSHJ14 × 8 (C)-01,02 (-F11)	12.0	106.21
KSHJ14 × 12 (C)-01,-02 (-F11)	12.0	106.21
KSHJ16 × 8 (C)-01,-02	20.0	—
KSHJ16 × 15 (C)-01,-02	20.0	—
KSHJ18 × 16 (C)-01,-02 (-F11)	25.0	221.28
KSHJ20 × 10 (C)-01,-02	30.0	—
KSHJ20 × 16 (C)-01,-02	30.0	—
KSHJ22 × 25 (C)-01,-02	35.0	—
KSHJ25 × 25 (C)-01,-11,-12 (-F11)	42.0	371.74
KSHJ27 × 25 (C)-01,-02,-11,-12	42.0	—
KSHJ30 × 30 (C)-01,-02,-03 (-F11)	60.0	531.06
KSHJ33 × 30 (C)-01,-02,-03	60.0	—
KSHJ36 × 50 (C)-01,-02,-03 (-F11)	72.0	531.06
KSHJ42 × 50 (C)-01,-02 (-F11)	85.0	637.27
KSHJ42 × 70 (C)-01,-02 (-F11)	85.0	637.27
KSHJ45 × 50 (C)-01,-02	85.0	—
KSHJ48 × 50 (C)-01,-02	120.0	—

Note: The KSHJ45 × 50(C)-01, and -02 use nominal number AN09 mounting nut prescribed in JIS B1554 (nuts for rolling bearings). Use a hook wrench (nominal 58 to 65 or 65 to 70) for tightening.

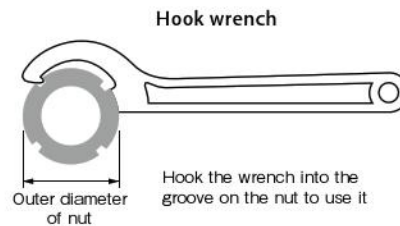

7. Ensure that the hardness of the surface directly impacting the piston rod of the shock absorber is over HRc40 hardness (excluding models with cap).
8. Be aware that performance and characteristics change depending on the operating temperature.

■ How to select shock absorbers

1. Confirm the thrust

Confirm the thrust that is used, and then check the prospective shock absorbers from the table of recommended cylinder bore sizes on page 10. If a shock absorber that is smaller than the recommended shock absorber is used, the shock absorber being used may be damaged in fewer operation cycles than is guaranteed.

2. Confirm the kinetic energy

Confirm I and II below, and then check pages 14 to 16 for the selection graphs for prospective shock absorbers from [1. Confirm the thrust]. (*)

I Impact object mass: m [kg]

II Impact speed: v [m/s]

Because "v" is the impact speed, not the average speed, when using a cylinder,

$$v = m [\text{cylinder stroke}] \div s [\text{operating time}] \times 2$$

Select a model in which I and II fit within the range enclosed by the capacity curves.

If multiple models are applicable, use the model that is closest to both the capacity curves and the operating conditions. The further the model you select is from the capacity curves and the operating conditions, the slower it will tend to be.

3. Confirm other specifications

Confirm that such specifications as the maximum operating frequency, maximum absorption capacity per unit of time, angle of eccentricity, and operating temperature range are within the range for the shock absorber that you selected.

* The value for the kinetic energy, E, can be found by doing the following calculation. However, the shock absorber's capacity for absorption changes depending on the impact speed. When the shock absorber is doing low-speed operations, it has less drag than when it is doing high-speed operations.

The maximum absorption capacity that is noted in the specifications is reached only at the maximum impact speed.

Therefore, do not choose a shock absorber by comparing E to the maximum absorption capacity; confirm the capacity using the selection graph.

$$E = \frac{1}{2} mv^2$$

E: Kinetic energy (J)

m: Impact object mass [kg]

v: Impact speed (m/s)

Range in the selection graph

Vertical axis range :

$$\text{Maximum impact speed} \geq v \text{ Impact speed (operating condition)}$$

Horizontal axis range :

$$\text{Shock absorber's maximum absorption capacity at the impact speed (v = m/s)} \geq \frac{E}{\text{Kinetic energy (operating condition)}}$$

Calculating the thrust energy is not necessary because the size of the shock absorber is limited by the thrust in step 1.

■ Koganei's selectable content

You can also select equipment from Koganei's homepage.

Visit <http://www.koganei.co.jp>.

The results of selections using the method above may differ from the results of selections for the selectable content on our homepage. If this happens, please contact us.

■ Example of selecting a shock absorber

[Operating conditions]

- ① Bore size of the cylinder being used: φ16
- ② Cylinder stroke: 100 mm = 0.1 m
- ③ Pressure applied to the cylinder: 0.6 MPa
- ④ Cylinder's operating time: 0.4 s
- ⑤ Impact object mass: 7 kg

1. Confirm the thrust

Either calculate or find the thrust in the cylinder thrust table on page 10. The cylinder thrust based on ① and ③ is about 121 N.

Cylinder thrust	100.5N	<	120.6N	<	126N
Cylinder bore size	φ16		φ16		φ20
Applied pressure	0.5MPa		0.6MPa		0.4MPa

As mentioned above, although the cylinder being used is φ16, the pressure applied to the cylinder exceeds 0.5 MPa, so consider the φ20 cylinder (lower than 0.4 MPa) and check the table of recommended cylinder bore sizes on page 10.

The following are prospective models.

- KSHJ10×6 • KSHJ10×10 • KSHJ10×15
- KSHJ12×6 • KSHJ12×10
- KSHJ14×8 • KSHJ14×12
- KSHJ16×15

2. Confirm the kinetic energy

I The impact object mass m = 7 kg from ⑤

II Find the impact speed, v, from ② and ④.

$$v = \frac{②}{④} \times 2 = \frac{0.1 \text{ m}}{0.4 \text{ s}} \times 2 = 0.5 \text{ m/s}$$

According to the selection graphs on pages 14 to 16, the shock absorber with the optimum absorption capacity for operating conditions is KSHJ12×6-02.

- KSHJ10×6 (with hexagon socket)
- KSHJ10×10

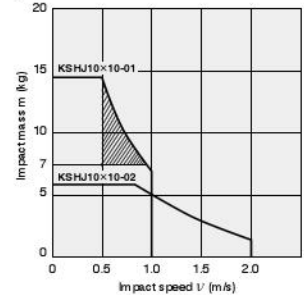
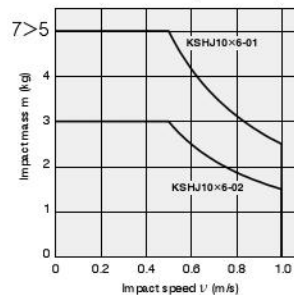

- KSHJ10×15

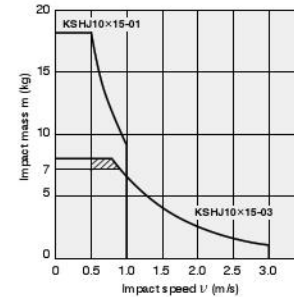

- KSHJ12×6 (with hexagon socket)

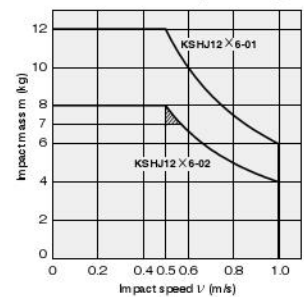

- KSHJ10×6 and 10×10-02 have an insufficient absorption capacity.
- KSHJ10×15-03, 12×6-01....KSHJ12×6-02 come closer to the operating conditions and capacity curves.
- The absorption capacities for all of the other shock absorbers are higher than that of KSHJ12×6-02, so they do not fall within the operating conditions and capacity curves.

3. Confirm other specifications

Verify that other operating conditions, such as the maximum operating frequency, maximum absorption capacity per unit of time, angle of eccentricity, and operating temperature range, are within the specified ranges for KSHJ12×6-02.

Selection Guidelines

Recommended cylinder bore size

Model	Cylinder bore																			
	φ4	φ6	φ8	φ10	φ12	φ16	φ20	φ25	φ32	φ40	φ50	φ63	φ80	φ100	φ125	φ140	φ160	φ180	φ200	
KSHJ4 ×3 (-F11)	◇	◎	○																	
KSHJ6 ×4 (-F11)		◇	◎	○																
KSHJ6 ×6 (-F11)		◇	◎	○																
KSHJ8 ×4 (-F11)(with hexagon socket)				◇	◎	◎	○													
KSHJ8 ×5 (-F11)			◇	◎	◎	○														
KSHJ8 ×8 (-F11)			◇	◎	◎	○														
KSHJ10 ×6 (-F11)(with hexagon socket)				◇	◎	◎	○													
KSHJ10 ×10 (-F11)				◇	◎	◎	○													
KSHJ10 ×15 (-F11)				◇	◎	◎	○													
KSHJ11 ×6-F11				◇	◎	◎	○													
KSHJ11 ×10-F11				◇	◎	◎	○													
KSHJ11 ×15-F11				◇	◎	◎	○													
KSHJ12 ×6 (-F11)(with hexagon socket)					◇	◎	◎	○												
KSHJ12 ×10 (-F11)					◇	◎	◎	○												
KSHJ14 ×8 (-F11)(with hexagon socket)						◇	◎	◎	○											
KSHJ14 ×12 (-F11)					◇	◎	◎	○												
KSHJ16 ×8 (with hexagon socket)							◇	◎	◎	○										
KSHJ16 ×15						◇	◎	◎	○											
KSHJ18 ×16 (-F11)							◇	◎	○											
KSHJ20 ×10 (with hexagon socket)								◇	◎	◎	○									
KSHJ20 ×16								◇	◎	○										
KSHJ22 ×25									◇	◎	◎	○								
KSHJ25 ×25 (-F11)									◇	◎	◎	○								
KSHJ27 ×25									◇	◎	◎	○								
KSHJ30 ×30 (-F11)										◇	◎	◎	○							
KSHJ33 ×30										◇	◎	◎	○							
KSHJ36 ×50 (-F11)											◇	◎	◎	○	○					
KSHJ42 ×50 (-F11)												◇	◎	◎	○	○				
KSHJ42 ×70 (-F11)													◇	◎	◎	○	○			
KSHJ45 ×50														◇	◎	◎	○	○		
KSHJ48 ×50															◇	◎	◎	○	○	○

◇ : 0.3 MPa or higher ◎ : 0.5 MPa or lower ○ : 0.4 MPa or lower

Note 1: If a shock absorber that is smaller than the recommended shock absorber is used, the shock absorber being used may be damaged in fewer operation cycles than the value that is guaranteed.

Note 2: KSHJ11×6, KSHJ11×10, and KSHJ11×15 have only inch specifications.

Cylinder thrust

N [lbf.]

Bore size mm [in.]	Pressure area mm ² [in. ²]	Air pressure MPa [psi.]								
		0.1 [15]	0.2 [29]	0.3 [44]	0.4 [58]	0.5 [73]	0.6 [87]	0.7 [102]	0.8 [116]	0.9 [131]
φ4	12.9 [0.01]	1.3 [0.2]	2.5 [0.6]	3.8 [0.9]	5 [1.1]	6.3 [1.4]	7.5 [1.7]	8.8 [2.0]	10.1 [2.3]	11.3 [2.5]
φ6	28.3 [0.04]	2.8 [0.6]	5.7 [1.3]	8.5 [1.9]	11.3 [2.5]	14.1 [3.2]	17.0 [3.8]	19.8 [4.5]	22.6 [5.1]	25.4 [5.7]
φ8	50.3 [0.08]	5 [1.1]	10.1 [2.3]	15.1 [3.4]	20.1 [4.5]	25.1 [5.6]	30.2 [6.8]	35.2 [7.9]	40.2 [9.0]	45.2 [10.2]
φ10	78.5 [0.12]	7.9 [1.8]	15.7 [3.5]	23.6 [5.3]	31.4 [7.1]	39.3 [8.8]	47.1 [10.6]	55 [12.4]	62.8 [14.1]	70.7 [15.9]
φ12	113 [0.18]	11.3 [2.5]	22.6 [5.1]	33.9 [7.6]	45.2 [10.2]	56.5 [12.7]	67.9 [15.3]	79.2 [17.8]	90.5 [20.3]	101.8 [22.9]
φ16	201 [0.31]	20.1 [4.5]	40.2 [9.0]	60.3 [13.6]	80.4 [18.1]	100.5 [22.6]	121 [27.2]	141 [31.7]	161 [36.2]	181 [40.7]
φ20	314 [0.49]	31.4 [7.1]	62.8 [14.1]	94.2 [21.2]	126 [28.3]	157 [35.3]	188 [42.3]	220 [49.5]	251 [56.4]	283 [63.7]
φ25	491 [0.76]	49.1 [11.0]	98.2 [22.1]	147 [33.0]	196 [44.1]	245 [55.1]	295 [66.3]	344 [77.3]	393 [88.3]	442 [99.4]
φ32	804 [1.25]	80.4 [18.1]	161 [36.2]	241 [54.2]	322 [72.4]	402 [90.4]	483 [108.6]	563 [126.6]	643 [144.6]	724 [162.8]
φ40	1257 [1.95]	126 [28.3]	251 [56.4]	377 [84.8]	503 [113.1]	628 [141.2]	754 [169.5]	880 [197.8]	1005 [225.9]	1131 [254.3]
φ50	1963 [3.04]	196 [44.1]	393 [40.1]	589 [132.4]	785 [176.5]	982 [220.8]	1178 [264.8]	1374 [308.9]	1571 [353.2]	1767 [397.2]
φ63	3117 [4.83]	312 [70.1]	623 [63.5]	935 [210.2]	1247 [280.3]	1559 [350.5]	1870 [420.4]	2182 [490.5]	2494 [560.7]	2806 [630.8]
φ80	5027 [7.80]	503 [113.1]	1005 [102.5]	1508 [339.0]	2011 [452.1]	2513 [564.9]	3016 [678.0]	3519 [791.1]	4021 [904.0]	4524 [1017.0]
φ100	7854 [12.17]	785 [176.5]	1571 [160.2]	2356 [529.6]	3142 [706.3]	3927 [882.8]	4712 [1059.3]	5498 [1236.0]	6283 [1412.5]	7069 [1589.2]
φ125	12272 [19.02]	1227 [275.8]	2454 [250.2]	3682 [827.7]	4909 [1103.6]	6136 [1379.4]	7363 [1655.3]	8590 [1931.1]	9817 [2206.9]	11045 [2483.0]
φ140	15394 [23.86]	1539 [346.0]	3079 [314.0]	4618 [1038.2]	6158 [1384.4]	7697 [1730.4]	9236 [2076.3]	10776 [2422.5]	12315 [2768.5]	13854 [3114.5]
φ160	20106 [31.16]	2011 [452.1]	4021 [904.0]	6032 [1356.0]	8042 [1808.0]	10053 [2260.0]	12064 [2712.1]	14074 [3164.0]	16085 [3616.1]	18096 [4068.1]
φ180	25447 [39.44]	2545 [572.1]	5089 [1144.1]	7634 [1716.2]	10179 [2288.3]	12723 [2860.2]	15268 [3432.4]	17813 [4004.5]	20358 [4576.7]	22902 [5148.6]
φ200	31416 [48.69]	3142 [706.4]	6283 [1412.5]	9425 [2118.8]	12566 [2824.9]	15708 [3531.3]	18850 [4237.6]	21991 [4943.8]	25133 [5650.1]	28274 [6356.3]

Selection Guidelines

Cautions for using the selection graphs

1. The selection graphs are calculated with a cylinder operating air pressure of 0.5 MPa.
2. The values in the selection graphs are for room temperature (20 to 25°). Be aware that performance and characteristics change depending on the operating temperature.
3. Select a shock absorber that is as close to, yet within, the capacity line(s).
4. You can select them on the Koganei home page. Go to <http://www.koganei.co.jp>
The results of selections using our catalog may differ from the results of selections on our homepage.

■ Selection graph

● KSHJ4 × 3(-F11)

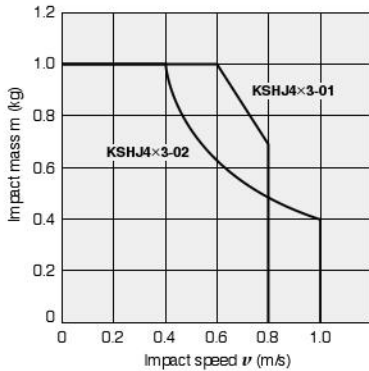

● KSHJ6 × 4(-F11)

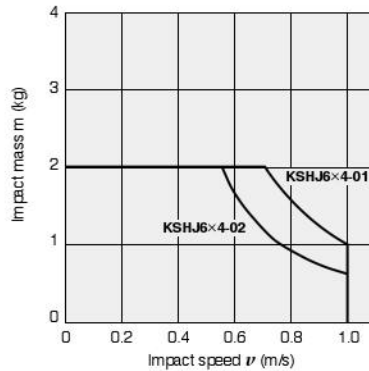

● KSHJ6 × 6(-F11)

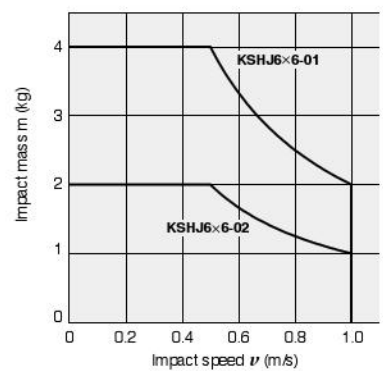

● KSHJ8 × 4(-F11)

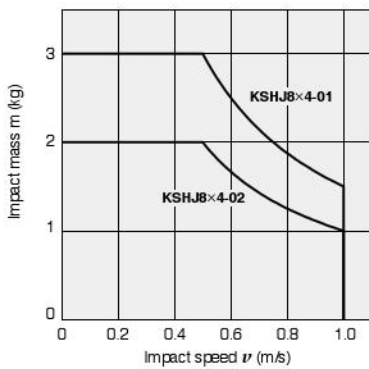

● KSHJ8 × 5(-F11)

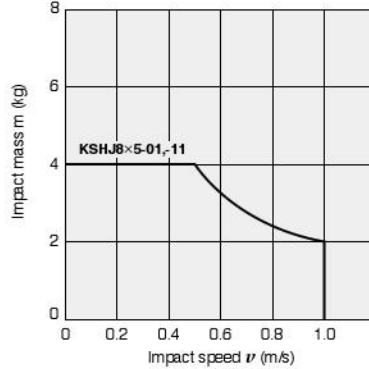

● KSHJ8 × 8(-F11)

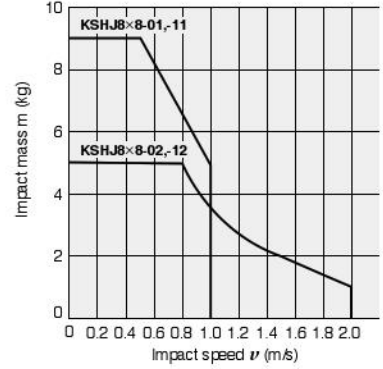

● KSHJ10 × 6(-F11)

● KSHJ11 × 6-F11

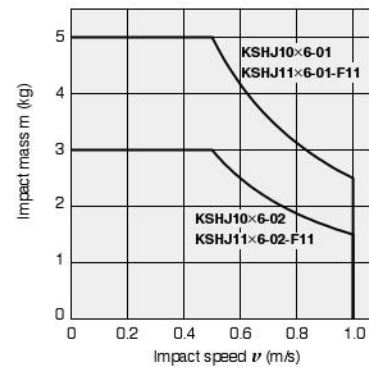

● KSHJ10 × 10(-F11)

● KSHJ11 × 10-F11

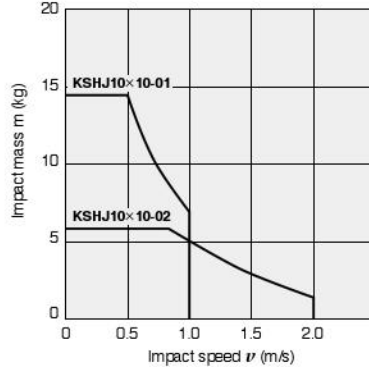

● KSHJ10 × 15(-F11)

● KSHJ11 × 15-F11

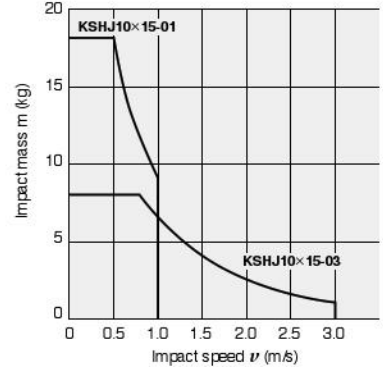

Selection Guidelines

● KSHJ12×6(-F11)

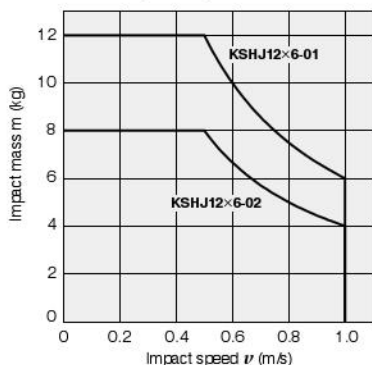

● KSHJ12×10(-F11)

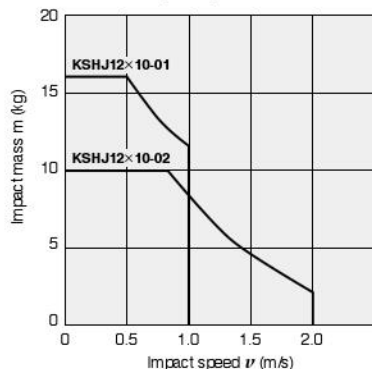

● KSHJ14×8(-F11)

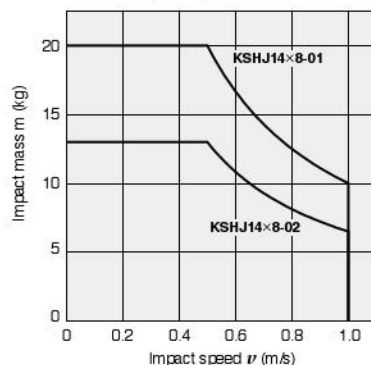

● KSHJ14×12(-F11)

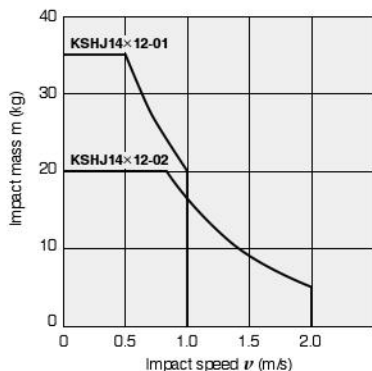

● KSHJ16×8

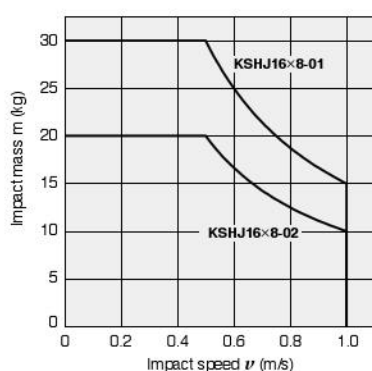

● KSHJ16×15

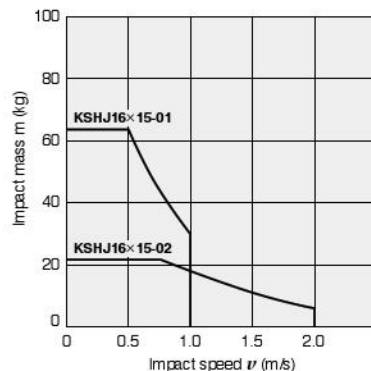

● KSHJ18×16(-F11)

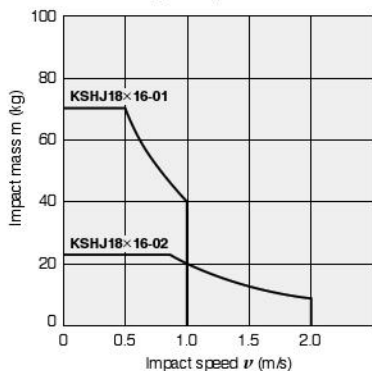

● KSHJ20×10

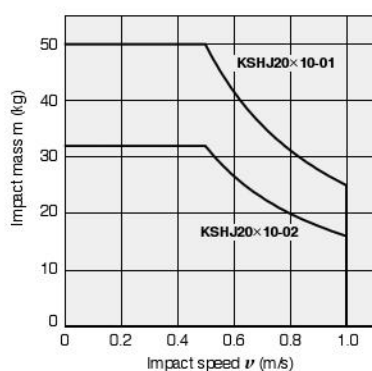

● KSHJ20×16

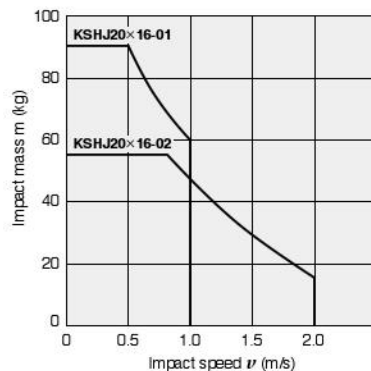

● KSHJ22×25

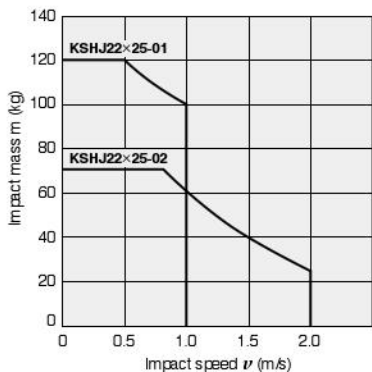

● KSHJ25×25(-F11)

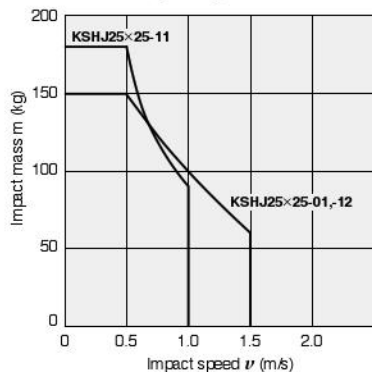

● KSHJ27×25

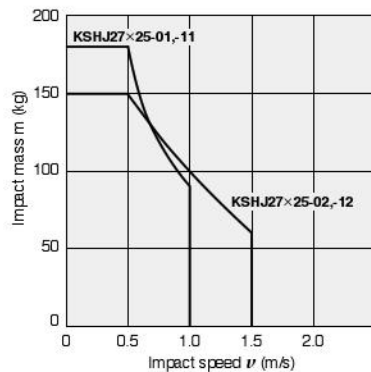

Selection Guidelines

● KSHJ30 × 30(-F11)

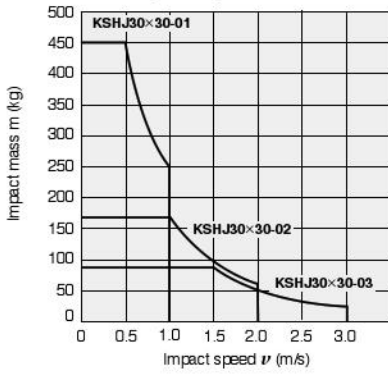

● KSHJ33 × 30

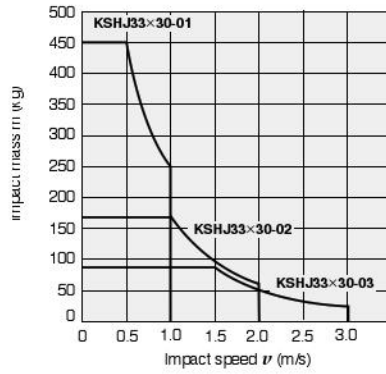

● KSHJ36 × 50(-F11)

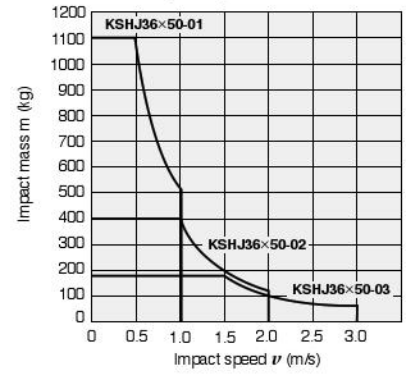

● KSHJ42 × 50(-F11)

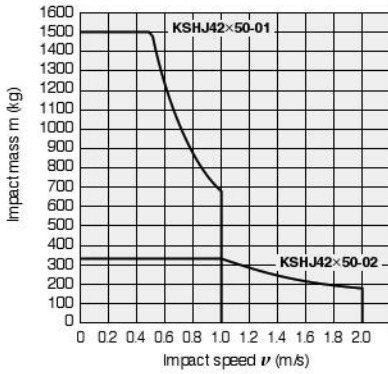

● KSHJ42 × 70(-F11)

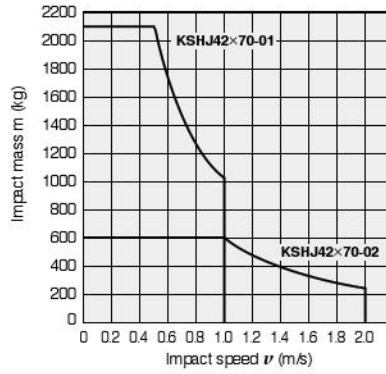

● KSHJ45 × 50

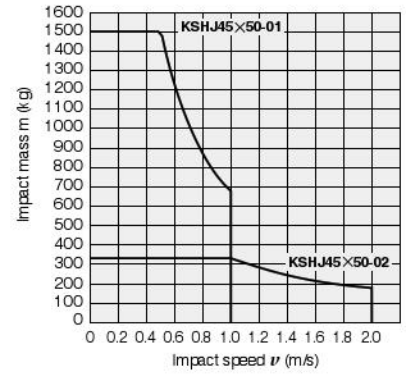

● KSHJ48 × 50

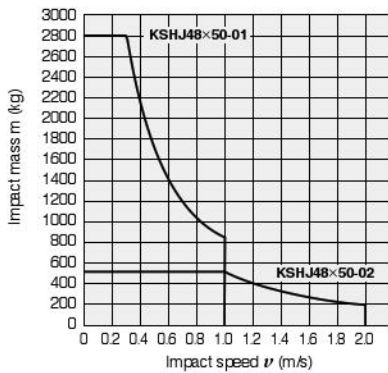

KSHJ

KSHY

KSHP

KSHC

Additional Parts

Linear orifice shock absorber

KSHJ Series



Specifications

Item	Model (in inches)	KSHJ4 × 3-01 (KSHJ4 × 3-01-F11)	KSHJ4 × 3-02 (KSHJ4 × 3-02-F11)	KSHJ6 × 4-01 (KSHJ6 × 4-01-F11)	KSHJ6 × 4-02 (KSHJ6 × 4-02-F11)	KSHJ6 × 6-01 (KSHJ6 × 6-01-F11)	KSHJ6 × 6-02 (KSHJ6 × 6-02-F11)
Maximum absorption capacity	J(in.lbs)	0.3 (2.7)	0.2 (1.8)	0.5 (4.4)	0.3 (2.7)	1 (8.9)	0.5 (4.4)
Absorption stroke	mm(in.)	3 (0.118)		4 (0.157)		6 (0.236)	
Impact speed range	m/s(ft/s)	0.1 to 0.8 (0.33 to 2.62)		0.1 to 1 (0.33 to 3.28)		0.1 to 1 (0.33 to 3.28)	
Maximum operating cycle	cycle/min	90				30	
Maximum absorption capacity per unit of time	J/min (in.lbs/min)	10 (88.6)		20 (177.1)		15 (132.8)	
Spring return force ^{Note1}	N	2		3		4	
Deflection angle		1° or less					
Operating temperature range ^{Note2}	°C(°F)	0 to 60 (32 to 140)					

Item	Model (in inches)	KSHJ8 × 4-01, -11 (KSHJ8 × 4-01, -11-F11)	KSHJ8 × 4-02, -12 (KSHJ8 × 4-02, -12-F11)	KSHJ8 × 5-01, -11 (KSHJ8 × 5-01-F11)	KSHJ8 × 8-01, -11 (KSHJ8 × 8-01, -11-F11)	KSHJ8 × 8-02, -12 (KSHJ8 × 8-02, -12-F11)	
Maximum absorption capacity	J(in.lbs)	0.75 (6.6)	0.5 (4.4)	1 (8.9)	2 (17.7)		
Absorption stroke	mm(in.)	4 (0.157)		5 (0.197)	8 (0.315)		
Impact speed range	m/s(ft/s)	0.1 to 1 (0.33 to 3.28)		0.1 to 1 (0.33 to 3.28)	0.1 to 1 (0.33 to 3.28)	0.1 to 2 (0.33 to 6.56)	
Maximum operating cycle	cycle/min	60		90			
Maximum absorption capacity per unit of time	J/min (in.lbs/min)	15 (132.8)		36 (318.8)	60 (531.4)		
Spring return force ^{Note1}	N	6		6	8.6		
Deflection angle		1° or less					
Operating temperature range ^{Note2}	°C(°F)	0 to 60 (32 to 140)					

Item	Model (in inches)	KSHJ10 × 6-01 (KSHJ10 × 6-01-F11) (KSHJ11 × 6-01-F11)	KSHJ10 × 6-02 (KSHJ10 × 6-02-F11) (KSHJ11 × 6-02-F11)	KSHJ10 × 10-01 (KSHJ10 × 10-01-F11) (KSHJ11 × 10-01-F11)	KSHJ10 × 10-02 (KSHJ10 × 10-02-F11) (KSHJ11 × 10-02-F11)	KSHJ10 × 15-01 (KSHJ10 × 15-01-F11) (KSHJ11 × 15-01-F11)	KSHJ10 × 15-03 (KSHJ10 × 15-03-F11) (KSHJ11 × 15-02-F11)
Maximum absorption capacity	J(in.lbs)	1.25 (11.1)	0.75 (6.6)	3 (26.6)		5 (44.3)	6.5 (57.6)
Absorption stroke	mm(in.)	6 (0.236)		10 (0.394)		15 (0.591)	
Impact speed range	m/s(ft/s)	0.1 to 1 (0.33 to 3.28)		0.1 to 1 (0.33 to 3.28)	0.1 to 2 (0.33 to 6.56)	0.1 to 1 (0.33 to 3.28)	0.1 to 3 (0.33 to 9.84)
Maximum operating cycle	cycle/min	60		90			
Maximum absorption capacity per unit of time	J/min (in.lbs/min)	45 (398.5)		120 (1062.7)		200 (1771.2)	
Spring return force ^{Note1}	N	8		8		9.8	
Deflection angle		1° or less					
Operating temperature range ^{Note2}	°C(°F)	0 to 60 (32 to 140)					

Item	Model (in inches)	KSHJ12 × 6-01 (KSHJ12 × 6-01-F11)	KSHJ12 × 6-02 (KSHJ12 × 6-02-F11)	KSHJ12 × 10-01 (KSHJ12 × 10-01-F11)	KSHJ12 × 10-02 (KSHJ12 × 10-02-F11)	KSHJ14 × 8-01 (KSHJ14 × 8-01-F11)	KSHJ14 × 8-02 (KSHJ14 × 8-02-F11)
Maximum absorption capacity	J(in.lbs)	3 (26.6)	2 (17.7)	6 (53.1)		5 (44.3)	3.25 (28.8)
Absorption stroke	mm(in.)	6 (0.236)		10 (0.394)		8 (0.315)	
Impact speed range	m/s(ft/s)	0.1 to 1 (0.33 to 3.28)		0.1 to 1 (0.33 to 3.28)	0.1 to 2 (0.33 to 6.56)	0.1 to 1 (0.33 to 3.28)	
Maximum operating cycle	cycle/min	60					
Maximum absorption capacity per unit of time	J/min (in.lbs/min)	80 (708.5)		220 (1948.3)		100 (885.6)	
Spring return force ^{Note1}	N	8		7.6		12.5	
Deflection angle		1° or less					
Operating temperature range ^{Note2}	°C(°F)	0 to 60 (32 to 140)					

Note1: The spring return force is the force of the piston rod when it returns from a full stroke. It is not stable, so cannot be used as other than rod return.

Note2: The shock absorber's shock absorbing capacity fluctuates based on speed and ambient temperature.

Use the product within the ranges of the selection graphs (impact mass, impact speed diagram) on pages 14 to 16.

Note3: KSHJ11 has only inch specifications.

* The maximum tightening torque of KSHJ11 is different from that of KSHJ10. See page 11 for details on the maximum tightening torque.

Specifications

Item	Model (in inches)	KSHJ14×12-01 (KSHJ14×12-01-F11)	KSHJ14×12-02 (KSHJ14×12-02-F11)	KSHJ16×8-01	KSHJ16×8-02	KSHJ16×15-01	KSHJ16×15-02
Maximum absorption capacity	J(in. lbs)	10 (88.6)		7.5	5	15	
Absorption stroke	mm(in.)	12 (0.472)		8		15	
Impact speed range	m/s(ft/s)	0.1 to 1 (0.33 to 3.28)	0.1 to 2 (0.33 to 6.56)	0.1 to 1		0.1 to 1	0.1 to 2
Maximum operating cycle	cycle/min	60		40			
Maximum absorption capacity per unit of time	J/min (in. lbs/min)	240 (2125.4)		130		280	
Spring return force ^{Note1}	N	9.2		12.5		17.4	
Deflection angle		1° or less		3° or less			
Operating temperature range ^{Note2}	°C(°F)	0 to 60 (32 to 140)					

Item	Model (in inches)	KSHJ18×16-01 (KSHJ18×16-01-F11)	KSHJ18×16-02 (KSHJ18×16-02-F11)	KSHJ20×10-01	KSHJ20×10-02	KSHJ20×16-01	KSHJ20×16-02
Maximum absorption capacity	J(in. lbs)	20 (177.0)		12.5	8	30	
Absorption stroke	mm(in.)	16 (0.630)		10		16	
Impact speed range	m/s(ft/s)	0.1 to 1 (0.33 to 3.28)	0.1 to 2 (0.33 to 6.56)	0.1 to 1		0.1 to 1	0.1 to 2
Maximum operating cycle	cycle/min	40		30			
Maximum absorption capacity per unit of time	J/min (in. lbs/min)	320 (2833.9)		200		450	
Spring return force ^{Note1}	N	22		15		22	
Deflection angle		3° or less					
Operating temperature range ^{Note2}	°C(°F)	0 to 60 (32 to 140)					

Item	Model (in inches)	KSHJ22×25-01	KSHJ22×25-02	KSHJ25×25-01	KSHJ25×25-11 (KSHJ25×25-01-F11)	KSHJ25×25-12 (KSHJ25×25-02-F11)
Maximum absorption capacity	J(in. lbs)	50		60 (531.0)		
Absorption stroke	mm(in.)	25		25 (0.984)		
Impact speed range	m/s(ft/s)	0.1 to 1	0.1 to 1	0.1 to 1.5	0.1 to 1 (0.33 to 3.28)	0.1 to 1.5 (0.33 to 4.92)
Maximum operating cycle	cycle/min	30				
Maximum absorption capacity per unit of time	J/min (in. lbs/min)	500		700	800 (7084.8)	
Spring return force ^{Note1}	N	28.5				
Deflection angle		3° or less				
Operating temperature range ^{Note2}	°C(°F)	0 to 60 (32 to 140)				

Item	Model (in inches)	KSHJ27×25-01,-11	KSHJ27×25-02,-12	KSHJ30×30-01 (KSHJ30×30-01-F11)	KSHJ30×30-02 (KSHJ30×30-02-F11)	KSHJ30×30-03 (KSHJ30×30-03-F11)
Maximum absorption capacity	J(in. lbs)	60		140 (1239.1)		
Absorption stroke	mm(in.)	25		30 (1.181)		
Impact speed range	m/s(ft/s)	0.1 to 1	0.1 to 1.5	0.1 to 1 (0.33 to 3.28)	0.1 to 2 (0.33 to 6.56)	0.1 to 3 (0.33 to 9.84)
Maximum operating cycle	cycle/min	30		20		
Maximum absorption capacity per unit of time	J/min (in. lbs/min)	800		900 (7970.4)		
Spring return force ^{Note1}	N	28.5		41.5		
Deflection angle		3° or less				
Operating temperature range ^{Note2}	°C(°F)	0 to 60 (32 to 140)				

Note1: The spring return force is the force of the piston rod when it returns from a full stroke. It is not stable, so cannot be used as other than rod return.

Note2: The shock absorber's shock absorbing capacity fluctuates based on speed and ambient temperature.

Use the product within the ranges of the selection graphs (impact mass, impact speed diagram) on pages 14 to 16.

Note3: KSHJ16×8, KSHJ16×15, KSHJ20×10, KSHJ20×16, KSHJ22×25, KSHJ27×25, KSHJ33×30, KSHJ45×50, and KSHJ48×50 do not have inch specifications.

KSHJ

KSHY

KSHP

KSHC

Additional Parts

Specifications

Item	Model (in inches)	KSHJ33 × 30			KSHJ36 × 50-01 (KSHJ36×50-01-F11)	KSHJ36 × 50-02 (KSHJ36×50-02-F11)	KSHJ36 × 50-03 (KSHJ36×50-03-F11)
		KSHJ33 × 30-01	KSHJ33 × 30-02	KSHJ33 × 30-03			
Maximum absorption capacity	J(in.lbs)	140			300 (2655.2)		
Absorption stroke	mm(in.)	30			50 (1.969)		
Impact speed range	m/s(ft/s)	0.1 to 1	0.1 to 2	0.1 to 3	0.1 to 1 (0.33 to 3.28)	0.1 to 2 (0.33 to 6.56)	0.1 to 3 (0.33 to 9.84)
Maximum operating cycle	cycle/min	20			20		
Maximum absorption capacity per unit of time	J/min (in.lbs/min)	900			1800 (15940.8)		
Spring return force ^{Note1}	N	41.5			66.5		
Deflection angle		3° or less					
Operating temperature range ^{Note2}	°C(°F)	0 to 60 (32 to 140)					

Item	Model (in inches)	KSHJ42 × 50		KSHJ42 × 70-01 (KSHJ42 × 70-01-F11)	KSHJ42 × 70-02 (KSHJ42 × 70-02-F11)
		KSHJ42 × 50-01 (KSHJ42 × 50-01-F11)	KSHJ42 × 50-02 (KSHJ42 × 50-02-F11)		
Maximum absorption capacity	J(in.lbs)	400 (3540.3)		600 (5310.4)	
Absorption stroke	mm(in.)	50 (1.969)		70 (2.756)	
Impact speed range	m/s(ft/s)	0.1 to 1 (0.33 to 3.28)	0.1 to 2 (0.33 to 6.56)	0.1 to 1 (0.33 to 3.28)	0.1 to 2 (0.33 to 6.56)
Maximum operating cycle	cycle/min	15		15	
Maximum absorption capacity per unit of time	J/min (in.lbs/min)	2400 (21254.4)		2400 (21254.4)	
Spring return force ^{Note1}	N	85.0		68.0	
Deflection angle		3° or less		1° or less	
Operating temperature range ^{Note2}	°C(°F)	0 to 60 (32 to 140)			

Item	Model (in inches)	KSHJ45 × 50		KSHJ48 × 50-01	KSHJ48 × 50-02
		KSHJ45 × 50-01	KSHJ45 × 50-02		
Maximum absorption capacity	J(in.lbs)	400		500	
Absorption stroke	mm(in.)	50		50	
Impact speed range	m/s(ft/s)	0.1 to 1	0.1 to 2	0.1 to 1	0.1 to 2
Maximum operating cycle	cycle/min	15		15	
Maximum absorption capacity per unit of time	J/min (in.lbs/min)	2400		3000	
Spring return force ^{Note1}	N	85.0		86.0	
Deflection angle		3° or less			
Operating temperature range ^{Note2}	°C(°F)	0 to 60			

Note1: The spring return force is the force of the piston rod when it returns from a full stroke. It is not stable, so cannot be used as other than rod return.

Note2: The shock absorber's shock absorbing capacity fluctuates based on speed and ambient temperature.

Use the product within the ranges of the selection graphs (impact mass, impact speed diagram) on pages 14 to 16.

Note3: KSHJ16×8, KSHJ16×15, KSHJ20×10, KSHJ20×16, KSHJ22×25, KSHJ27×25, KSHJ33×30, KSHJ45×50, KSHJ48×50 do not have inch specifications.

Mass

Specifications in mm

9

Model	Main unit ^{Note}	Additional mass	Additional parts' mass		
		With plastic cap	Mounting nut (1 ea.)	Stopper nut	Side mounting bracket
KSHJ4 × 3-01, -02	1.8	0.1	0.2	1	7
KSHJ6 × 4-01, -02	4	0.2	0.4	2	8
KSHJ6 × 6-01, -02	5	0.2	0.4	2	8
KSHJ8 × 4-01, -02, -11, -12 (with hexagon socket)	10	0.5	0.6(0.9)	4	12
KSHJ8 × 5-01, -11	10	0.5	0.6(0.9)	4	12
KSHJ8 × 8-01, -02, -11, -12	11.5	0.5	0.6(0.9)	4	12
KSHJ10 × 6-01, -02 (with hexagon socket)	21	0.6	1.2	7	15
KSHJ10 × 10-01, -02	22	0.6	1.2	7	15
KSHJ10 × 15-01, -03	28	0.6	1.2	7	15
KSHJ12 × 6-01, 02 (with hexagon socket)	31	1.2	1.9	8	22
KSHJ12 × 10-01, -02	37	1.2	1.9	8	22
KSHJ14 × 8-01, 02 (with hexagon socket)	55	1.4	4	15	41
KSHJ14 × 12-01, -02	58	1.4	4	15	41
KSHJ16 × 8-01, -02 (with hexagon socket)	73	1.4	6.6	28	65
KSHJ16 × 15-01, -02	83	1.4	6.6	28	65
KSHJ18 × 16-01, -02	113	3.0	8.8	37	100
KSHJ20 × 10-01, -02 (with hexagon socket)	131	3.0	12.2	55	110
KSHJ20 × 16-01, -02	156	3.0	12.2	55	110
KSHJ22 × 25-01, -02	233	7.0	18.2	82	390
KSHJ25 × 25-01	307	7.0	23	95	360
KSHJ25 × 25-11, -12	300	7.0	24.5	95	360
KSHJ27 × 25-01, -02	415	7.0	42	180	460
KSHJ27 × 25-11, -12	395	7.0	54	180	460
KSHJ30 × 30-01, -02, -03	520	50	32.5	140	455
KSHJ33 × 30-01, -02, -03	675	50	47.5	390	2800
KSHJ36 × 50-01, -02, -03	1070	110	95.5	330	2650
KSHJ42 × 50-01, -02	1310	110	93	320	2400
KSHJ42 × 70-01, -02	1500	110	93	320	2400
KSHJ45 × 50-01, -02	1610	110	123	420	3400
KSHJ48 × 50-01, -02	1830	210	100	400	3400

Calculation example: The mass of KSHJ10×10C-01-S-2 (with cap, stopper, and side mount) is
 $22 + 0.6 + 7 + 15 = 44.6g$

Note: The weight of the main unit includes the weight of 2 mounting nuts.

Specifications in inches

02

Model	Main unit ^{Note1}	Additional mass	Additional parts' mass	
		With plastic cap	Mounting nut (1 ea.)	Stopper nut
KSHJ4 × 3-01, -02 -F11	0.1	0.004	0.01	0.04
KSHJ6 × 4-01, -02 -F11	0.2	0.007	0.04	0.1
KSHJ6 × 6-01, -02 -F11	0.2	0.007	0.04	0.1
KSHJ8 × 4-01, -02, -11, -12 -F11	0.4	0.02	0.06	0.2
KSHJ8 × 5-01 -F11	0.4	0.02	0.06	0.2
KSHJ8 × 8-01, -02, -11, -12 -F11	0.5	0.02	0.06	0.2
KSHJ10 × 6-01, -02 -F11	0.7	0.02	0.07	0.4
KSHJ10 × 10-01, -02 -F11	0.8	0.02	0.07	0.4
KSHJ10 × 15-01, -03 -F11	1.0	0.02	0.07	0.4
KSHJ11 × 6-01, -02 -F11 ^{Note2}	1.0	0.02	0.09	0.4
KSHJ11 × 10-01, -02 -F11 ^{Note2}	1.2	0.02	0.09	0.4
KSHJ11 × 15-01, -03 -F11 ^{Note2}	1.4	0.02	0.09	0.4
KSHJ12 × 6-01, 02 -F11	1.3	0.04	0.1	0.5
KSHJ12 × 10-01, -02 -F11	1.5	0.04	0.1	0.5
KSHJ14 × 8-01, 02 -F11	2.2	0.05	0.2	0.7
KSHJ14 × 12-01, -02 -F11	2.2	0.05	0.2	0.7
KSHJ18 × 16-01, -02 -F11	4.8	0.1	0.4	2.5
KSHJ25 × 25-11, -12 -F11	11.3	0.2	1.2	4.4
KSHJ30 × 30-01, -02, -03 -F11	20.6	1.8	1.3	5.5
KSHJ36 × 50-01, -02, -03 -F11	33.9	3.9	3.0	9.8
KSHJ42 × 50-01, -02 -F11	51.5	3.9	3.4	10.8
KSHJ42 × 70-01, -02 -F11	59.6	3.9	3.4	10.8

Calculation example: The mass of KSHJ10×10C-01-S-2 (with cap and stopper) is
 $0.8 + 0.02 + 0.4 = 1.58oz$

Note1: The weight of the main unit includes the weight of 2 mounting nuts.

Note2: KSHJ11 has only inch specifications.

KSHJ

KSHY

KSHP

KSCH

Additional Parts

Order Codes (specifications in mm)

• 4×3

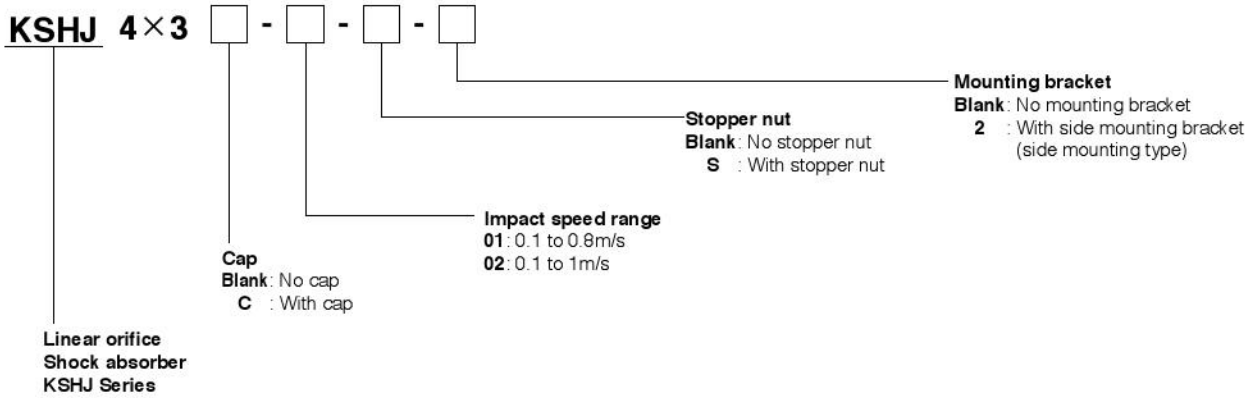

• 6×4

6×6

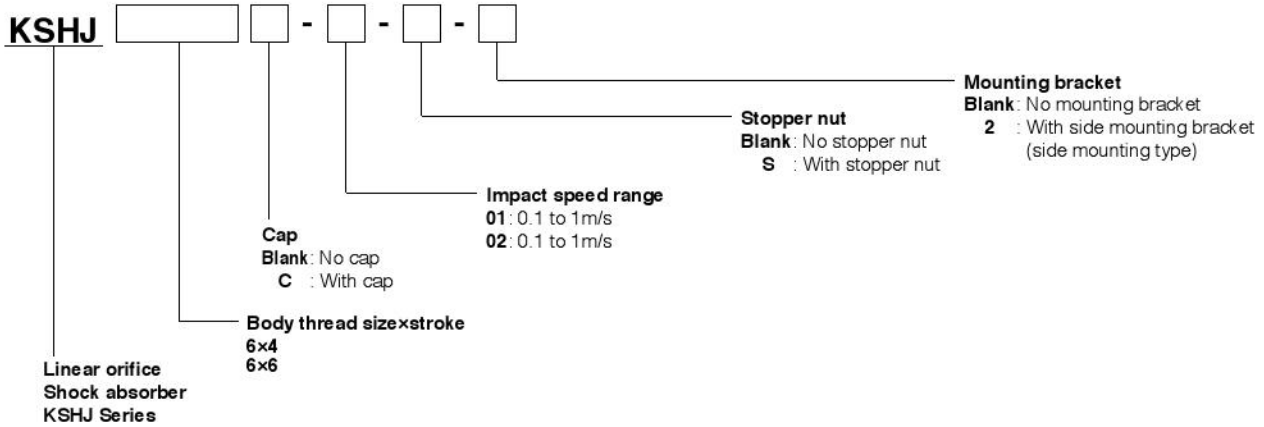

• 8×5

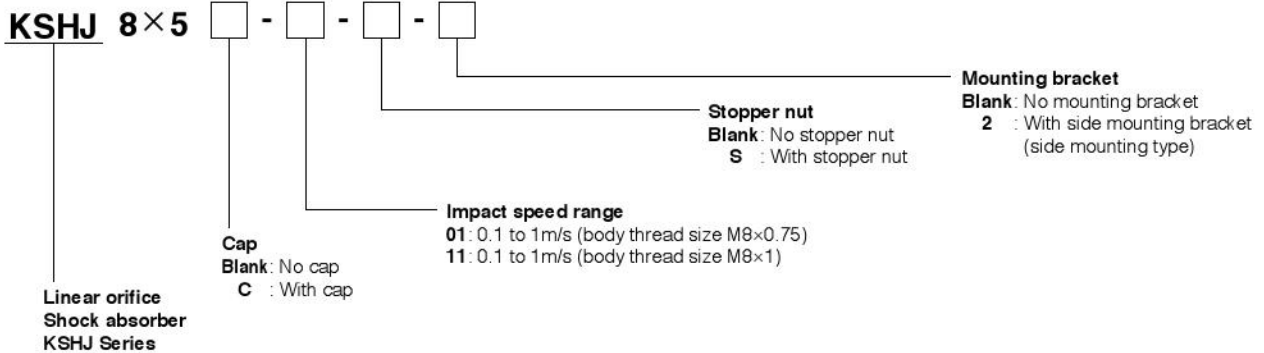

• 8×8

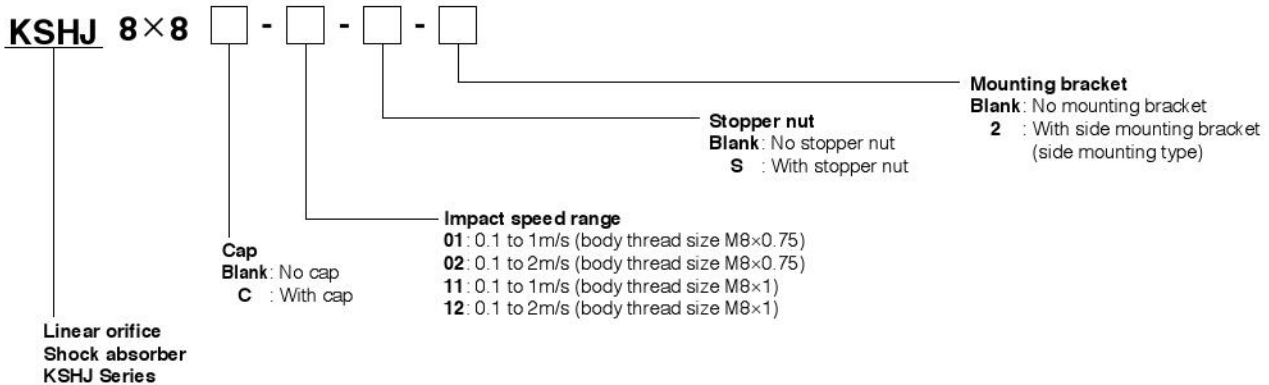

Order Codes (specifications in mm)

• 10×15

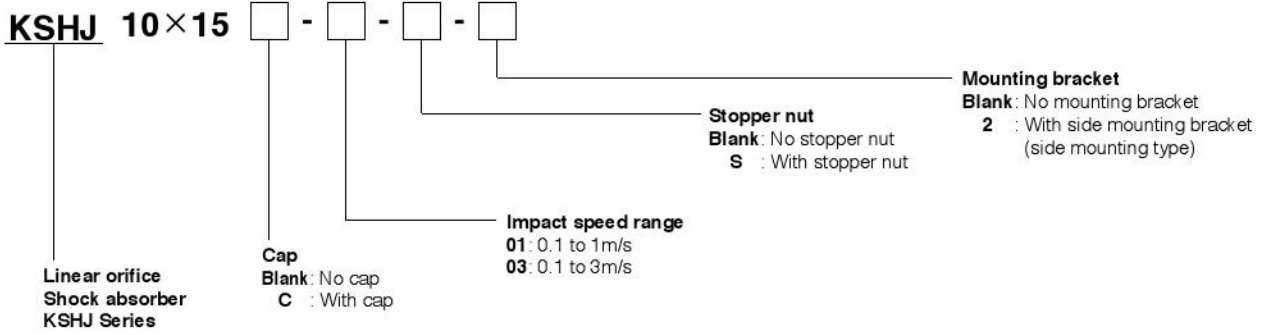

• 10×10 12×10 14×12 16×15 18×16 20×16 22×25

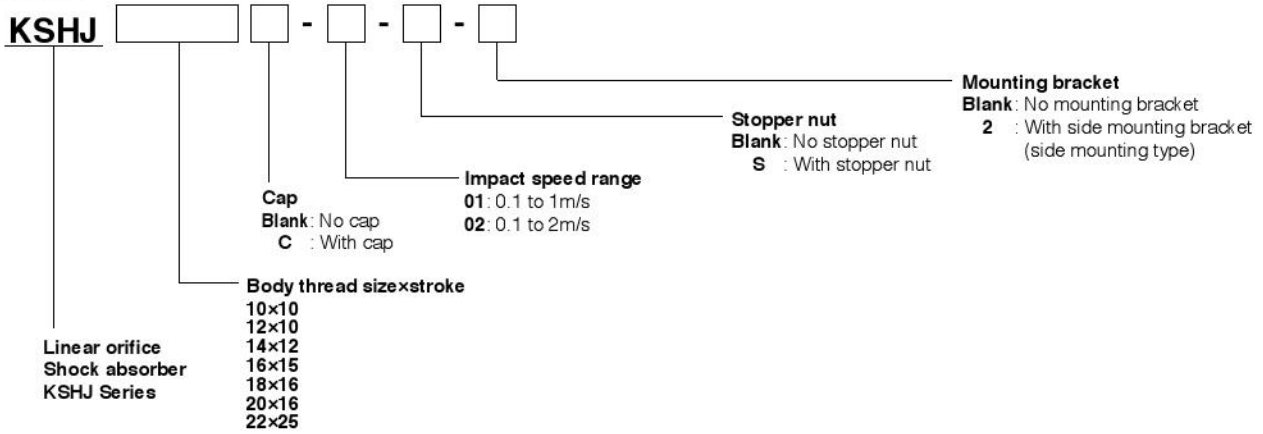

• 25×25

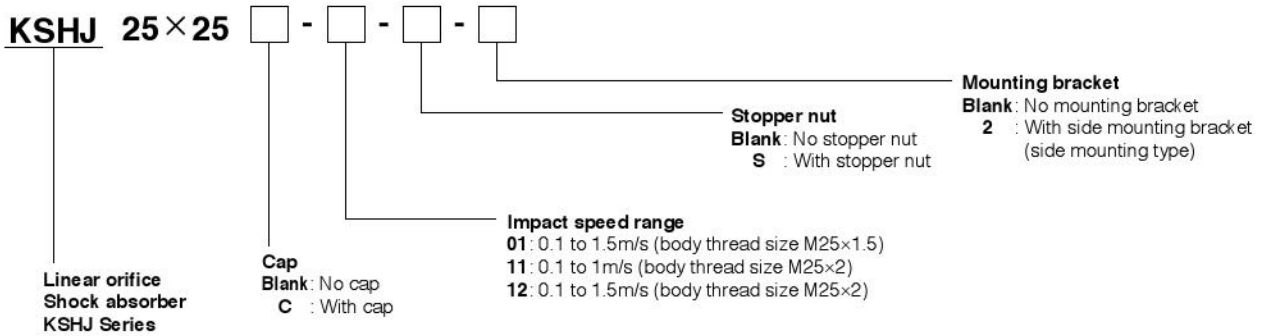

• 27×25

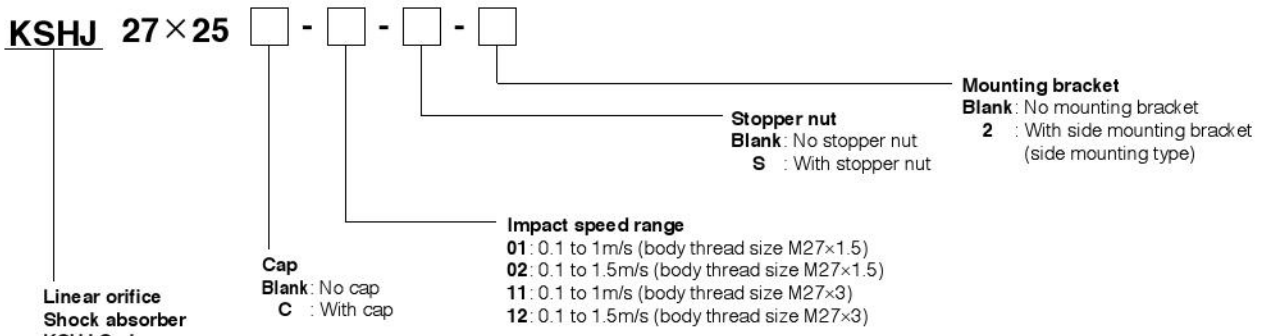

KSHJ

KSHY

KSHP

KSCH

Additional Parts

Order Codes (specifications in mm)

- 30 × 30
- 33 × 30
- 36 × 50

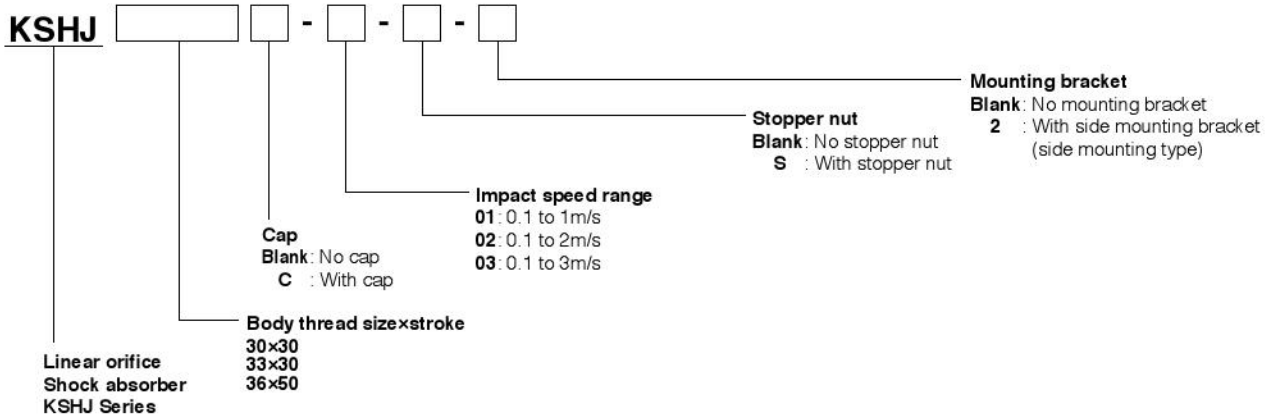

- 42 × 50
- 42 × 70
- 45 × 50
- 48 × 50

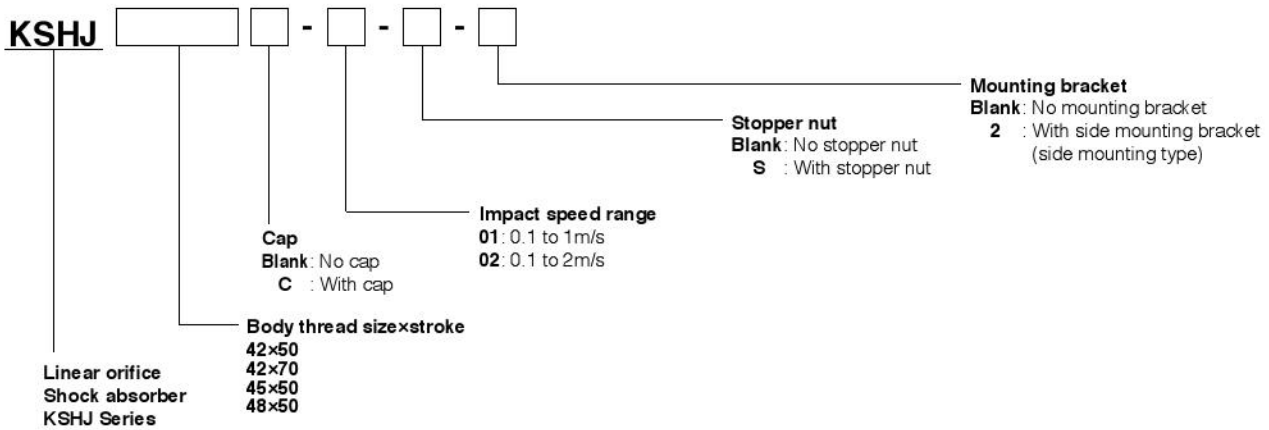

Short stroke type (with hexagon socket)

- 8 × 4
- 10 × 6
- 12 × 6
- 14 × 8
- 16 × 8
- 20 × 10

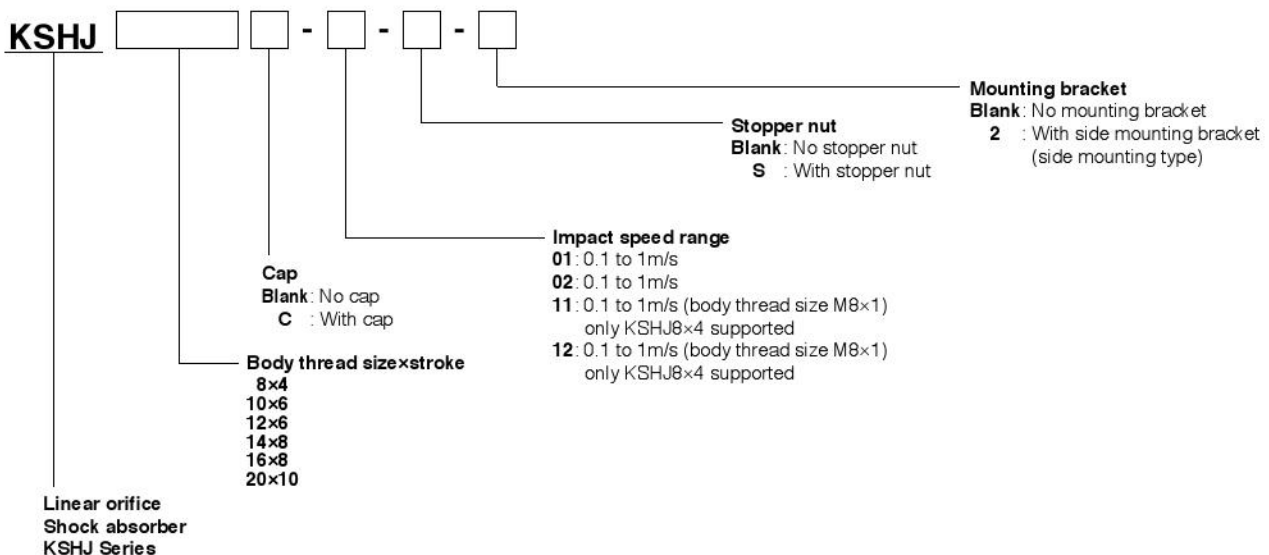

Order Codes (specifications in mm)

Additional Parts (no specifications in inches)

● **Mounting nut** (M4 to M20: 1 pack has 10 units)^{Note}
(M22 to M48: 1 pack has 2 units)

N - KSH - M



Thread size

- 4: For KSHJ4
- 6: For KSHJ6
- 8: For KSHJ8(-01,02)
- 8-11: For KSHJ8(-11,12)
- 10: For KSHJ10
- 12: For KSHJ12
- 14: For KSHJ14
- 16: For KSHJ16
- 18: For KSHJ18
- 20: For KSHJ20
- 22: For KSHJ22
- 25: For KSHJ25-01
- 25-11: For KSHJ25(-11,12)
- 27: For KSHJ27(-01,02)
- 27-11: For KSHJ27(-11,12)
- 30: For KSHJ30
- 33: For KSHJ33
- 36: For KSHJ36
- 42: For KSHJ42
- 45: For KSHJ45
- 48: For KSHJ48

● **Stopper nut**

S - KSH - M



Thread size

- 4: For KSHJ4
- 6: For KSHJ6
- 8: For KSHJ8(-01,02)
- 8-11: For KSHJ8(-11,12)
- 10: For KSHJ10
- 12: For KSHJ12
- 14: For KSHJ14
- 16: For KSHJ16
- 18: For KSHJ18
- 20: For KSHJ20
- 22: For KSHJ22
- 25: For KSHJ25-01
- 25-11: For KSHJ25(-11,12)
- 27: For KSHJ27(-01,02)
- 27-11: For KSHJ27(-11,12)
- 30: For KSHJ30
- 33: For KSHJ33
- 36: For KSHJ36
- 42: For KSHJ42
- 45: For KSHJ45
- 48: For KSHJ48

● **Side mounting bracket**

2 - KSH - M



Thread size

- 4: For KSHJ4
- 6: For KSHJ6
- 8: For KSHJ8(-01,02)
- 8-11: For KSHJ8(-11,12)
- 10: For KSHJ10
- 12: For KSHJ12
- 14: For KSHJ14
- 16: For KSHJ16
- 18: For KSHJ18
- 20: For KSHJ20
- 22: For KSHJ22
- 25: For KSHJ25-01
- 25-11: For KSHJ25(-11,12)
- 27: For KSHJ27(-01,02)
- 27-11: For KSHJ27(-11,12)
- 30: For KSHJ30
- 33: For KSHJ33
- 36: For KSHJ36
- 42: For KSHJ42
- 45: For KSHJ45
- 48: For KSHJ48

Note: The mounting nut for thread size M45 is nominal number AN09 prescribed in JIS B1554 (nuts for rolling bearings).

* For the dimension diagrams of the additional parts, see pages 72 to 76.

* The stopper nut and side mount are made from mild steel (nickel plated).

Inner Construction and Major Parts and Materials

●M4 to M27 size (10-32UNF to 1-12UNF) * The inch sizes are inside the ().

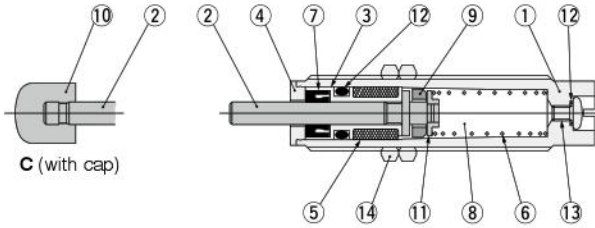

Note: Some parts and interior shapes may vary depending on size.

No.	Name	Materials
①	Body ^{Note1}	Copper alloy (nickel plated)
②	Piston rod ^{Note2}	Steel (nickel plated)
③	Sleeve	Copper alloy
④	Plug	Stainless steel
⑤	Accumulator	Synthetic rubber
⑥	Spring	Spring steel
⑦	Rod seal	Synthetic rubber
⑧	Oil	Special oil
⑨	Piston ring	Copper alloy
⑩	Cap	Plastic (POM)
⑪	Collar ^{Note3}	Stainless steel, copper alloy
⑫	O-ring	Synthetic rubber
⑬	Screw ^{Note4}	Mild steel (zinc plated)
⑭	Mounting nut	Mild steel (nickel plated)

Note1: KSHJ4, 6, and 8×4 are stainless steel

2: KSHJ8, 10×10, and 12×10 are stainless steel

3: KSHJ6 and 8 are copper alloy

KSHJ10 and 12, and 14×12 are sintered metal

4: KSHJ4, 6, and 8 are nickel plated

●M30 to M48 size (1 1/4-12UNF to 1 3/4-12UN) * The inch sizes are inside the ().

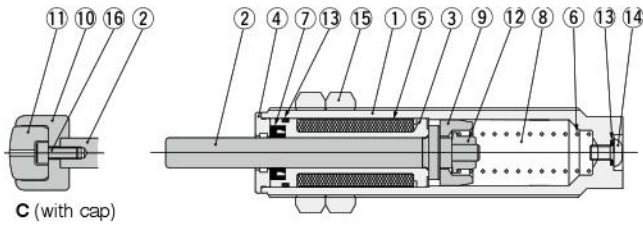

Note: Some parts and interior shapes may vary depending on size.

No.	Name	Materials
①	Body	Free-cutting steel (nickel plated)
②	Piston rod	Steel (nickel plated)
③	Sleeve	Copper alloy
④	Plug	Stainless steel
⑤	Accumulator	Synthetic rubber
⑥	Spring	Spring steel
⑦	Rod seal	Synthetic rubber
⑧	Oil	Special oil
⑨	Piston ring ^{Note}	Copper alloy
⑩	Metal cap	Stainless steel
⑪	Cap	Plastic (POM)
⑫	Collar	Stainless steel
⑬	O-ring	Synthetic rubber
⑭	Button head screw	Stainless steel
⑮	Mounting nut	Mild steel (nickel plated)
⑯	Hexagon socket head screw	Mild steel (nickel plated)

Note: KSHJ42, 45, and 48 are stainless steel

Dimensions (mm)

●No rod end cap: KSHJ4×3, KSHJ6×4, KSHJ6×6

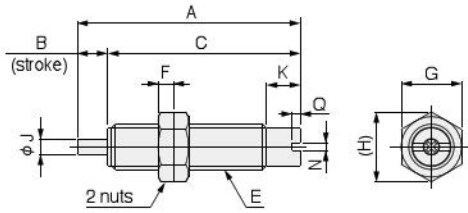

●With rod end cap: KSHJ4×3C, KSHJ6×4C, KSHJ6×6C

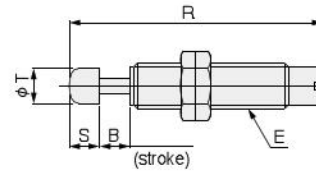

Model	Symbol	A	B	C	E	F	G	H	J	K	N	Q	R	S	T
KSHJ4×3 (C)-01,-02		25	3	22	M4×0.5	2	5.5	6.4	1.2	3	1	1.1	28.5	3.5	3.2
KSHJ6×4 (C)-01,-02		29.5	4	25.5	M6×0.75	2	8	9.2	2	4.5	1	1	33.5	4	4.6
KSHJ6×6 (C)-01,-02		35.5	6	29.5	M6×0.75	2	8	9.2	2	5.5	1	1	39.5	4	4.6

●No rod end cap: KSHJ□×□-□

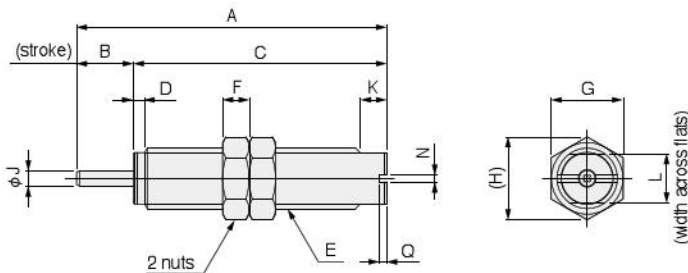

●With rod end cap: KSHJ□×□C-□

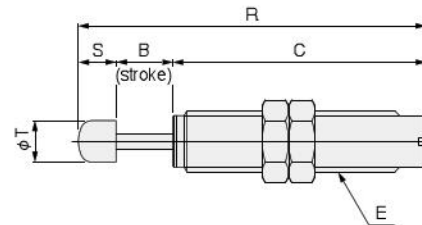

Model	Symbol	A	B	C	D	E	F	G	H	J	K	L	N	Q	R	S	T
KSHJ8×5 (C)-01		37	5	32	1.2	M8×0.75	2	10	11.5	2.5	3	7	1.3	1.5	42	5	6.5
KSHJ8×5 (C)-11		37	5	32	1.2	M8×1	3	10	11.5	2.5	3	7	1.3	1.5	42	5	6.5
KSHJ8×8 (C)-01,-02		46	8	38	1.2	M8×0.75	2	10	11.5	2.5	3	7	1.3	1.5	51	5	6.5
KSHJ8×8 (C)-11,-12		46	8	38	1.2	M8×1	3	10	11.5	2.5	3	7	1.3	1.5	51	5	6.5
KSHJ10×10 (C)-01,-02		60	10	50	2	M10×1	3	12	13.9	3	5	8.5	1.3	1.5	68	8	8
KSHJ10×15 (C)-01,-03		77	15	62	2.3	M10×1	3	12	13.9	3	5	8.5	1.3	1.5	85	8	8
KSHJ12×10 (C)-01,-02		66	10	56	2	M12×1	4	14	16.2	3	5	10.5	1.3	1.5	76	10	10
KSHJ14×12 (C)-01,-02		72	12	60	2	M14×1.5	5	17	19.6	4	5	12	1.3	1.5	82	10	11
KSHJ16×15 (C)-01,-02		82	15	67	3	M16×1.5	7	19	21.9	4	7	13	1.8	2	92	10	11
KSHJ18×16 (C)-01,-02		88	16	72	3	M18×1.5	8	21	24.2	5	7	15	1.8	2	103	15	15
KSHJ20×16 (C)-01,-02		93	16	77	3	M20×1.5	8	24	27.7	5	7	17	1.8	2	108	15	15
KSHJ22×25 (C)-01,-02		125	25	100	3	M22×1.5	9	27	31.2	6	10	19	1.8	2	143	18	18
KSHJ25×25 (C)-01		125	25	100	3	M25×1.5	10	30	34.6	6	10	22	1.8	2	143	18	18
KSHJ25×25 (C)-11,-12		125	25	100	3	M25×2	10	30	34.6	6	10	22	1.8	2	143	18	18

●No rod end cap: KSHJ27×25-□

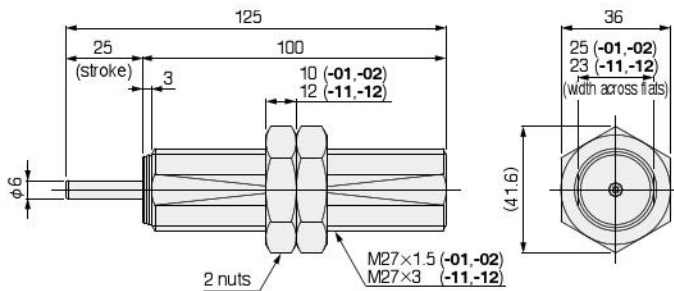

●With rod end cap: KSHJ27×25C-□

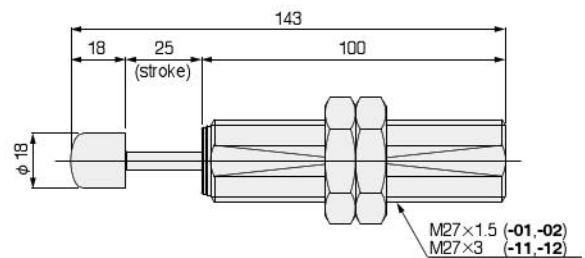

Dimensions (mm)

●No rod end cap: KSHJ□×□-□

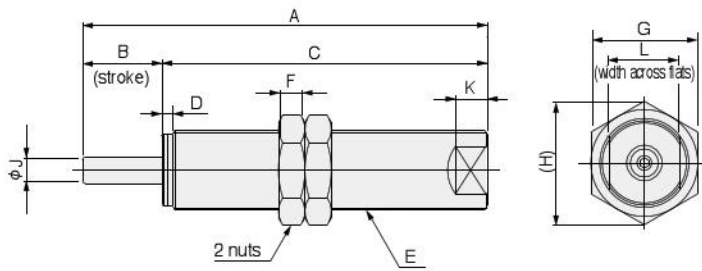

●With rod end cap: KSHJ□×□C-□

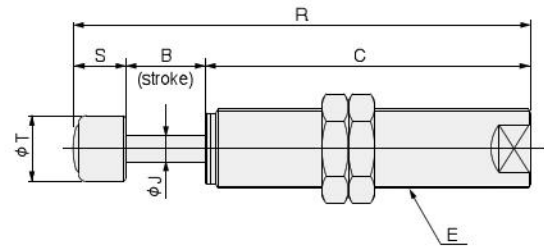

Model	Symbol	A	B	C	D	E	F	G	H	J	K	L	R	S	T
KSHJ30×30 (C)-01,-02,-03		153	30	123	4	M30×1.5	10	36	41.6	10	12	24	173	20	25
KSHJ33×30 (C)-01,-02,-03		153	30	123	4	M33×1.5	10	41	47.3	10	12	27	173	20	25
KSHJ36×50 (C)-01,-02,-03		218	50	168	5	M36×1.5	15	46	53.1	12	15	30	243	25	32
KSHJ42×50 (C)-01,-02		220	50	170	5	M42×1.5	15	50	57.7	12	20	36	245	25	32
KSHJ42×70 (C)-01,-02		275	70	205	5	M42×1.5	15	50	57.7	12	20	36	300	25	32
KSHJ48×50 (C)-01,-02		230	50	180	6	M48×2	15	55	63.5	14	20	40	263	33	38

●No rod end cap: KSHJ45×50-01, -02

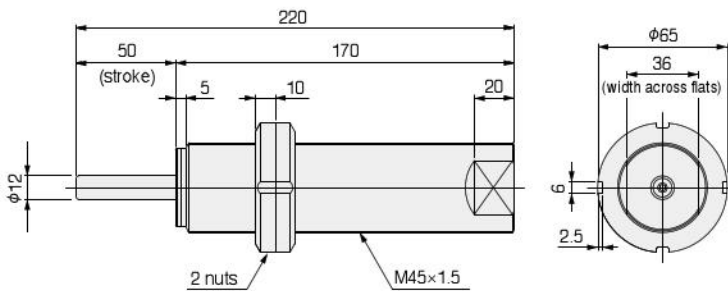

●With rod end cap: KSHJ45×50C-01, -02

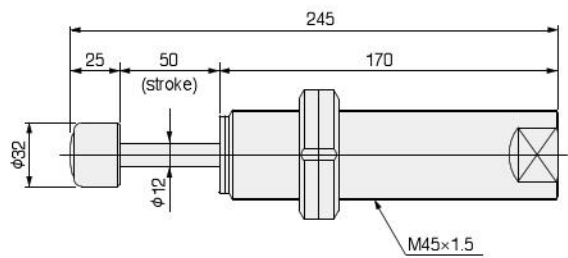

Short stroke type (with hexagon socket)

●No rod end cap: KSHJ□×□-□

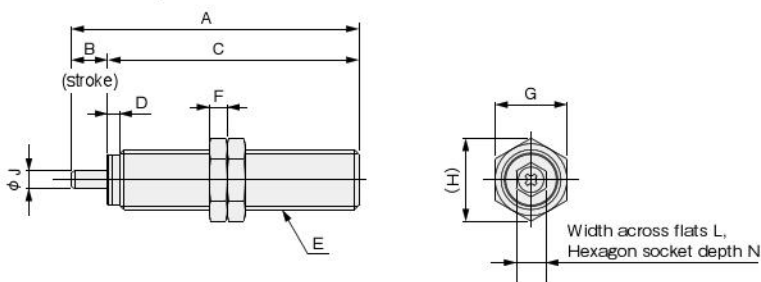

●With rod end cap: KSHJ□×□C-□

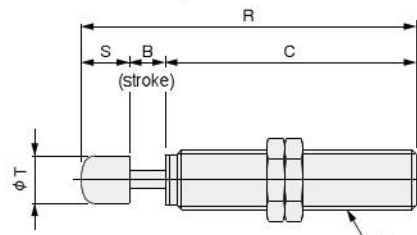

Model	Symbol	A	B	C	D	E	F	G	H	J	L	N	R	S	T
KSHJ8×4 (C)-01,-02		37	4	33	2.2	M8×0.75	2	10	11.5	2.5	4	2	42	5	6.5
KSHJ8×4 (C)-11,-12		37	4	33	2.2	M8×1.0	3	10	11.5	2.5	4	2	42	5	6.5
KSHJ10×6 (C)-01,-02		48	6	42	2	M10×1	3	12	13.9	3	5	3	56	8	8
KSHJ12×6 (C)-01,-02		48	6	42	2	M12×1	4	14	16.2	3	6	3	58	10	10
KSHJ14×8 (C)-01,-02		61	8	53	2	M14×1.5	5	17	19.6	4	6	3	71	10	11
KSHJ16×8 (C)-01,-02		61	8	53	3	M16×1.5	7	19	21.9	4	6	4	71	10	11
KSHJ20×10 (C)-01,-02		69	10	59	3	M20×1.5	8	24	27.7	5	6	4	84	15	15

Order Codes (specifications in inches)

• 4×3

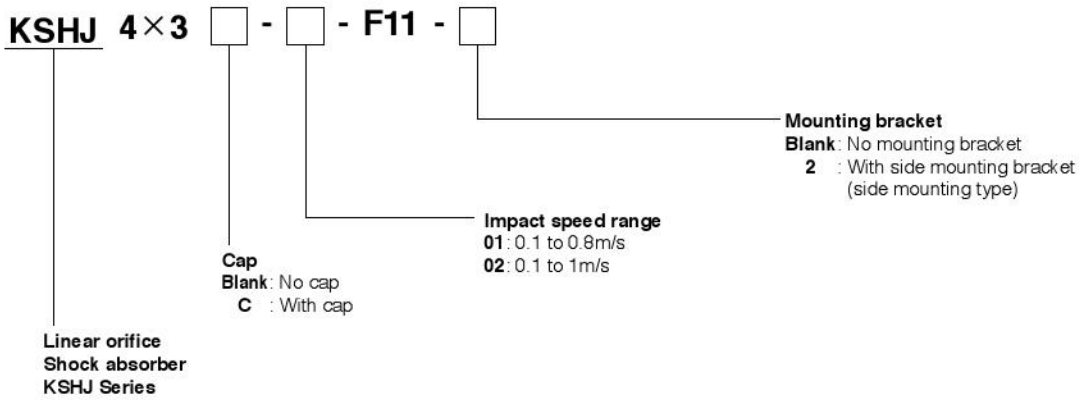

• 6×4

6×6

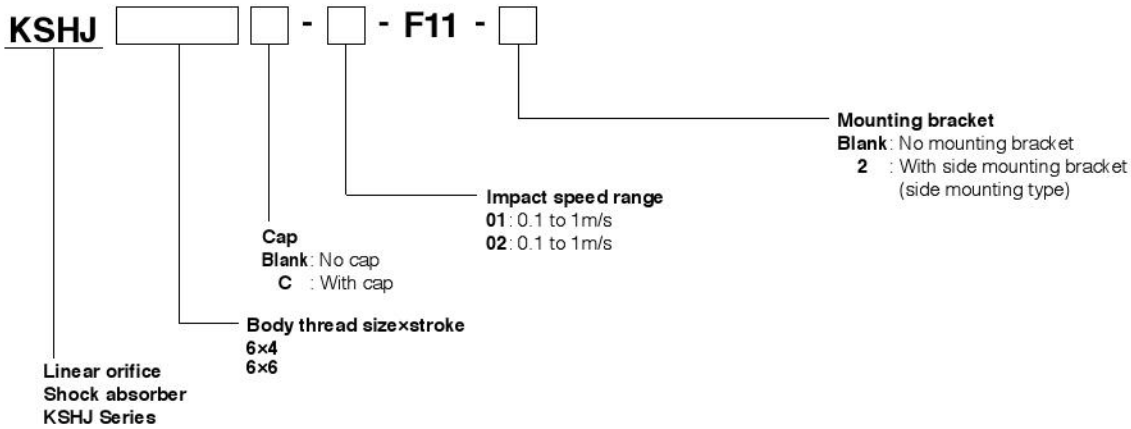

• 8×5

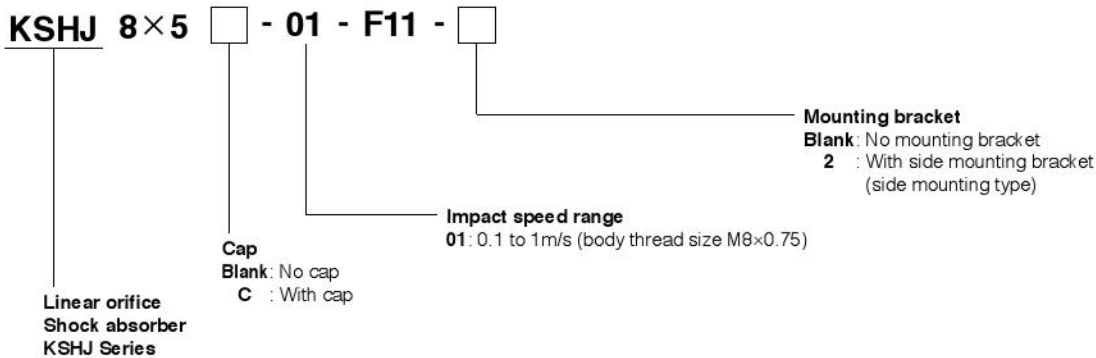

• 8×8

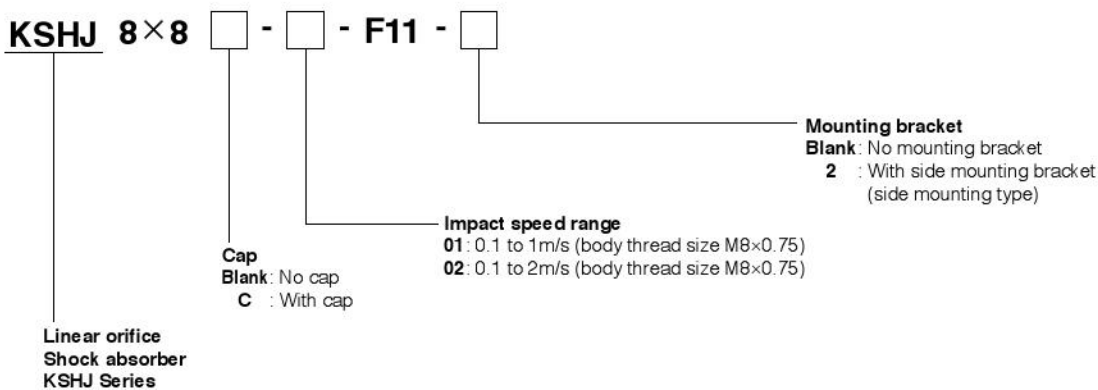

KSHJ

KSHY

KSHP

KSHC

Additional Parts

Order Codes (specifications in inches)

• 10×15

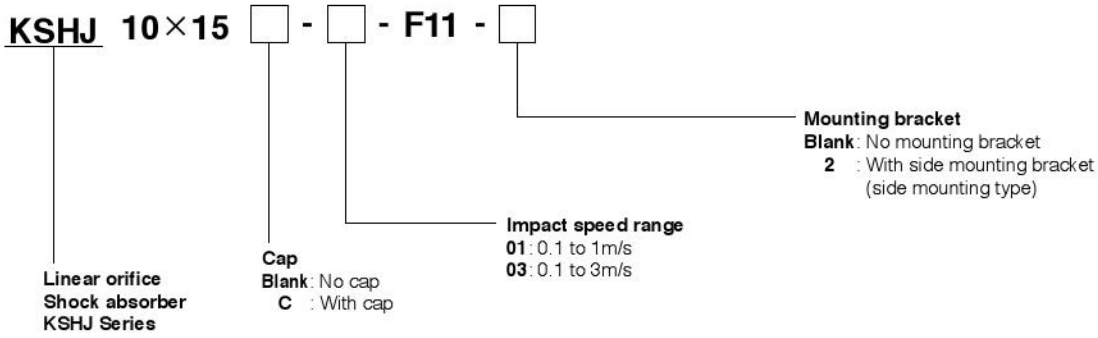

• 10×10 12×10 14×12 18×16

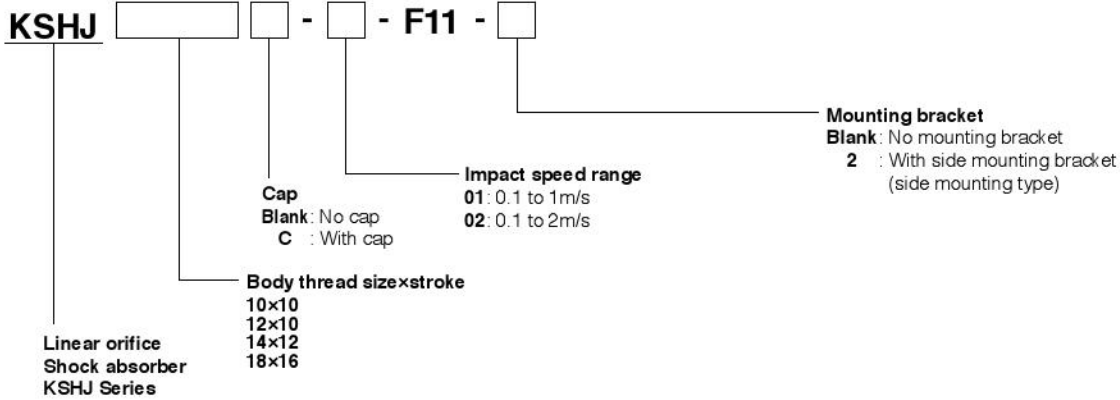

• 25×25

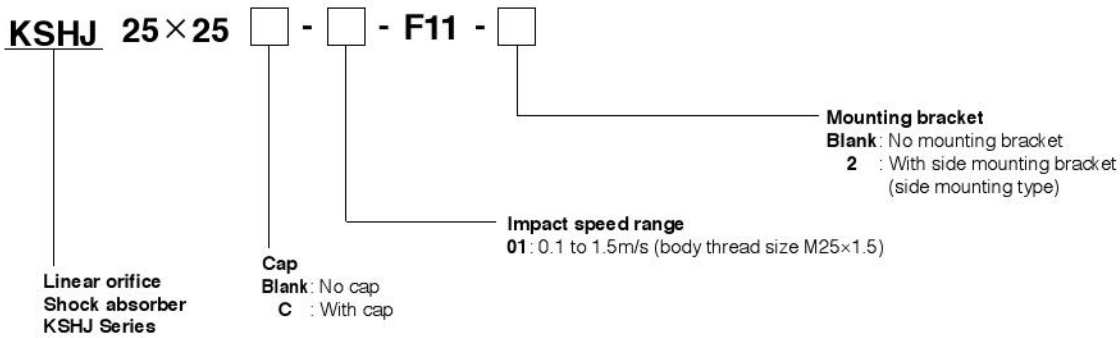

• 30×30 36×50

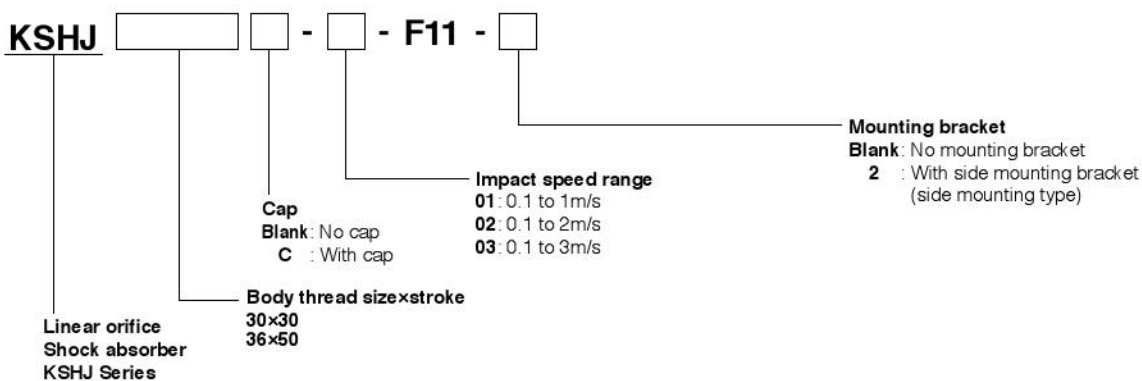

Order Codes (specifications in inches)

- 42×50
- 42×70

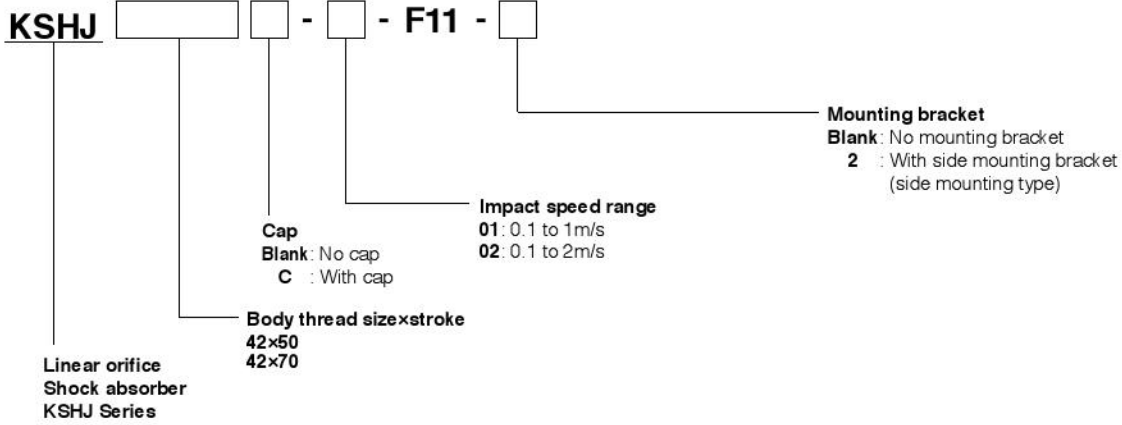

Short stroke type (with hexagon socket)

- 8×4
- 10×6
- 12×6
- 14×8

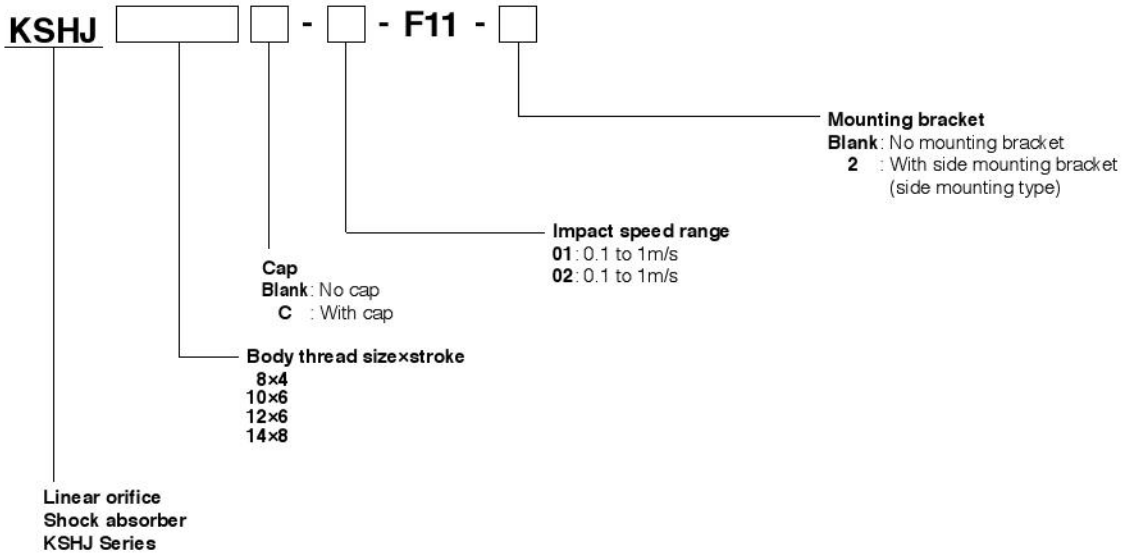

KSHJ

KSHY

KSHP

KSHC

Additional Parts

Dimensions (in)

●No rod end cap: KSHJ4×3, KSHJ6×4, KSHJ6×6

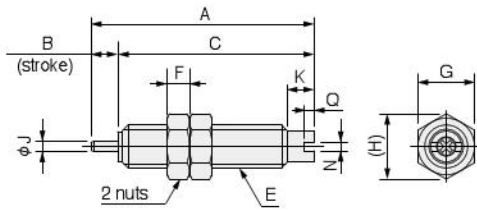

●With rod end cap: KSHJ4×3C, KSHJ6×4C, KSHJ6×6C

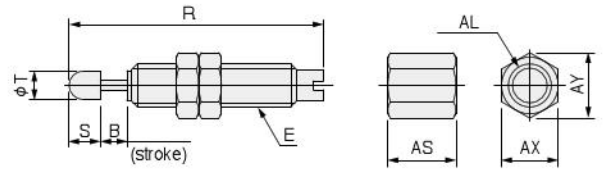

Model	Symbol	A	B	C	E	F	G	H	J	K	N	Q	R	S
KSHJ4×3 (C)-01,-02-F11		0.984	0.118	0.866	#10-32 UNF	0.1	1/4	0.289	0.047	0.118	0.039	0.043	1.122	0.138
KSHJ6×4 (C)-01,-02-F11		1.161	0.157	1.004	1/4-32 UNEF	0.1	3/8	0.433	0.079	0.177	0.039	0.039	1.319	0.157
KSHJ6×6 (C)-01,-02-F11		1.398	0.236	1.161	1/4-32 UNEF	0.1	3/8	0.433	0.079	0.217	0.039	0.039	1.555	0.157

Model	Symbol	T	AL	AS	AX	AY
KSHJ4×3 (C)-01,-02-F11		0.126	#10-32 UNF	0.3	1/4	0.289
KSHJ6×4 (C)-01,-02-F11		0.181	1/4-32 UNEF	0.4	3/8	0.433
KSHJ6×6 (C)-01,-02-F11		0.181	1/4-32 UNEF	0.4	3/8	0.433

●No rod end cap: KSHJ□×□-□

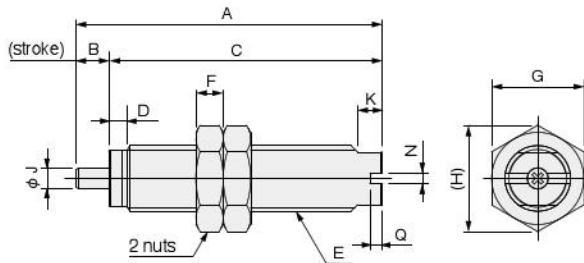

●With rod end cap: KSHJ□×□C-□

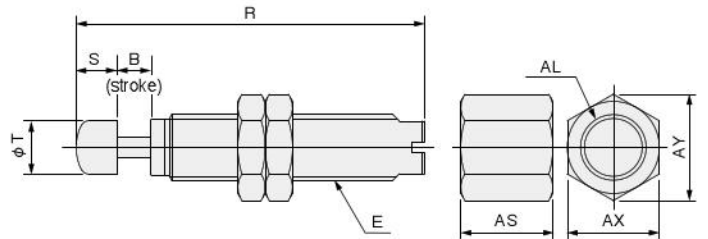

Model	Symbol	A	B	C	D	E	F	G	H	J	K	N	Q	R
KSHJ8×4 (C)-01,-02-F11		1.457	0.157	1.299	0.087	5/16-32 UNEF	0.13	7/16	0.505	0.098	0.118	0.051	0.059	1.654
KSHJ8×5 (C)-01-F11		1.457	0.197	1.26	0.047	5/16-32 UNEF	0.13	7/16	0.505	0.098	0.118	0.051	0.059	1.654
KSHJ8×8 (C)-01,-02-F11		1.811	0.315	1.496	0.047	5/16-32 UNEF	0.13	7/16	0.505	0.098	0.118	0.051	0.059	2.008
KSHJ10×6 (C)-01,-02-F11		1.89	0.236	1.654	0.079	3/8-32 UNEF	0.13	1/2	0.577	0.118	0.197	0.051	0.059	2.205
KSHJ10×10 (C)-01,-02-F11		2.362	0.394	1.969	0.079	3/8-32 UNEF	0.13	1/2	0.577	0.118	0.197	0.051	0.059	2.677
KSHJ10×15 (C)-01,-03-F11		3.031	0.591	2.441	0.079	3/8-32 UNEF	0.13	1/2	0.577	0.118	0.197	0.051	0.059	3.346
KSHJ11×6 (C)-01,-02-F11		1.89	0.236	1.654	0.079	7/16-28 UNEF	0.15	9/16	0.65	0.118	0.197	0.051	0.059	2.205
KSHJ11×10 (C)-01,-02-F11		2.362	0.394	1.969	0.079	7/16-28 UNEF	0.15	9/16	0.65	0.118	0.197	0.051	0.059	2.677
KSHJ11×15 (C)-01,-03-F11		3.031	0.591	2.441	0.079	7/16-28 UNEF	0.15	9/16	0.65	0.118	0.197	0.051	0.059	3.346
KSHJ12×6 (C)-01,-02-F11		1.89	0.236	1.654	0.079	1/2-20 UNF	0.15	5/8	0.722	0.118	0.197	0.051	0.059	2.283
KSHJ12×10 (C)-01,-02-F11		2.598	0.394	2.205	0.079	1/2-20 UNF	0.15	5/8	0.722	0.118	0.197	0.051	0.059	2.992
KSHJ14×8 (C)-01,-02-F11		2.402	0.315	2.087	0.079	9/16-18 UNF	7/32	11/16	0.794	0.157	0.197	0.051	0.059	2.795
KSHJ14×12 (C)-01,-02-F11		2.835	0.472	2.362	0.079	9/16-18 UNF	7/32	11/16	0.794	0.157	0.197	0.051	0.059	3.228
KSHJ18×16 (C)-01,-02-F11		3.465	0.63	2.835	0.118	3/4-16 UNF	1/4	15/16	1.082	0.197	0.276	0.071	0.079	4.055
KSHJ25×25 (C)-01,-02-F11		4.921	0.984	3.937	0.118	1-12 UNF	3/8	1 1/4	1.443	0.236	0.394	0.071	0.079	5.63

Model	Symbol	S	T	AL	AS	AX	AY
KSHJ8×4 (C)-01,-02-F11		0.197	0.256	5/16-32 UNEF	7/16	7/16	0.505
KSHJ8×5 (C)-01-F11		0.197	0.256	5/16-32 UNEF	7/16	7/16	0.505
KSHJ8×8 (C)-01,-02-F11		0.197	0.256	5/16-32 UNEF	7/16	7/16	0.505
KSHJ10×6 (C)-01,-02-F11		0.315	0.315	3/8-32 UNEF	11/16	1/2	0.577
KSHJ10×10 (C)-01,-02-F11		0.315	0.315	3/8-32 UNEF	11/16	1/2	0.577
KSHJ10×15 (C)-01,-03-F11		0.315	0.315	3/8-32 UNEF	11/16	1/2	0.577
KSHJ11×6 (C)-01,-02-F11		0.315	0.315	7/16-28 UNEF	11/16	9/16	0.65
KSHJ11×10 (C)-01,-02-F11		0.315	0.315	7/16-28 UNEF	11/16	9/16	0.65
KSHJ11×15 (C)-01,-03-F11		0.315	0.315	7/16-28 UNEF	11/16	9/16	0.65
KSHJ12×6 (C)-01,-02-F11		0.394	0.394	1/2-20 UNF	11/16	5/8	0.722
KSHJ12×10 (C)-01,-02-F11		0.394	0.394	1/2-20 UNF	11/16	5/8	0.722
KSHJ14×8 (C)-01,-02-F11		0.394	0.433	9/16-18 UNF	3/4	11/16	0.794
KSHJ14×12 (C)-01,-02-F11		0.394	0.433	9/16-18 UNF	3/4	11/16	0.794
KSHJ18×16 (C)-01,-02-F11		0.591	0.591	3/4-16 UNF	11/2	15/16	1.082
KSHJ25×25 (C)-01,-02-F11		0.709	0.709	1-12 UNF	11/2	1 1/4	1.443

Dimensions (in)

● No rod end cap: KSHJ□×□-□

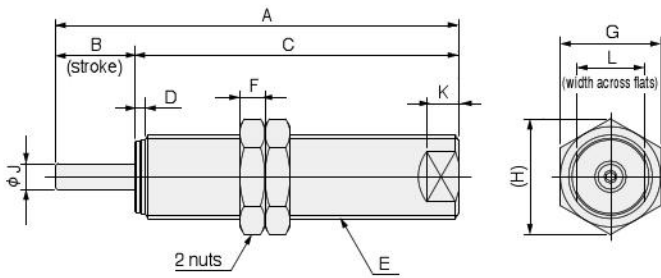

● With rod end cap: KSHJ□×□C-□

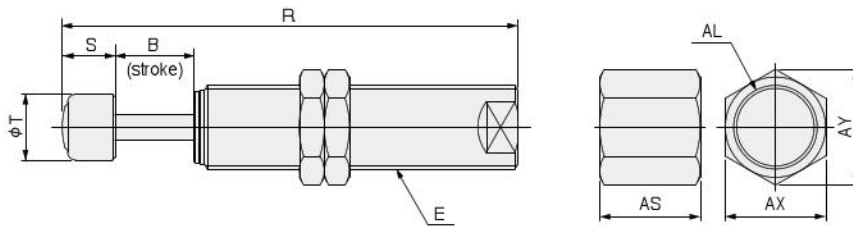

Model	Symbol	A	B	C	D	E	F	G	H	J	K	L	R	S
KSHJ30 × 30 (C)-01,-02,-03-F11		6.024	1.181	4.843	0.157	1 1/4-12 UNF	3/8	1 1/2	1.732	0.394	0.472	1	6.811	0.787
KSHJ36 × 50 (C)-01,-02,-03-F11		8.583	1.969	6.614	0.197	1 3/8-12 UNF	5/8	1 11/16	1.948	0.472	0.591	1 1/8	9.567	0.984
KSHJ42 × 50 (C)-01,-02-F11		8.661	1.969	6.693	0.197	1 3/4-12 UN	5/8	2	2.309	0.472	0.787	1 1/2	9.646	0.984
KSHJ42 × 70 (C)-01,-02-F11		10.827	2.756	8.071	0.197	1 3/4-12 UN	5/8	2	2.309	0.472	0.787	1 1/2	11.811	0.984

Model	Symbol	T	AL	AS	AX	AY
KSHJ30 × 30 (C)-01,-02,-03-F11		0.984	1 1/4-12 UNF	1 1/2	1 1/2	1.732
KSHJ36 × 50 (C)-01,-02,-03-F11		1.26	1 3/8-12 UNF	2	1 11/16	1.948
KSHJ42 × 50 (C)-01,-02-F11		1.26	1 3/4-12 UN	2	2	2.309
KSHJ42 × 70 (C)-01,-02-F11		1.26	1 3/4-12 UN	2	2	2.309

KSHJ

KSHY

KSHP

KSHC

Additional Parts

Side load resistant Linear Orifice[®] Shock Absorber KSHY Series

Now on
sale!

Side load resistant
Linear Orifice[®] Shock Absorber

Can be used without an adaptor to handle rotary side load!

Stopper unnecessary

Each size can withstand up to 10°

Maximum of more than 2 million operation cycles!



Wide range of variations

M6 to M20

7 sizes 132 models

KSHJ

KSHY

KSHP

KSHC

Additional Parts

Handling instructions and precautions



General precautions

Cover the unit when mounting it in locations where it might be subject to excessive dust, dripping water, dripping oil, etc. Dents, scratches, water, oil, or dust on the piston rod results in damage and decreases service life.



Mounting

1. Keep the angle of eccentricity, resulting from the load direction and the axis of the shock absorber, under the specified values on page 49. If an eccentric load exceeding the specifications is applied, it could result in breakage or impaired returns. If there is concern that an eccentric load exceeding the specified values will be applied, install a guide, or similar mechanism.

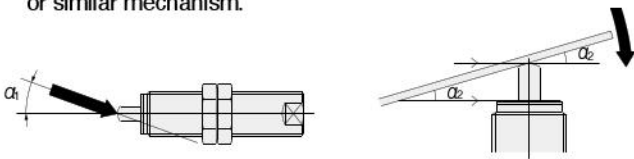

2. For swing impacts, the ends of the piston rod and the cap wear down due to the sliding between the contact area and the tip of the shock absorber. Although you can reduce wear by applying grease, observe the following precautions when applying grease.

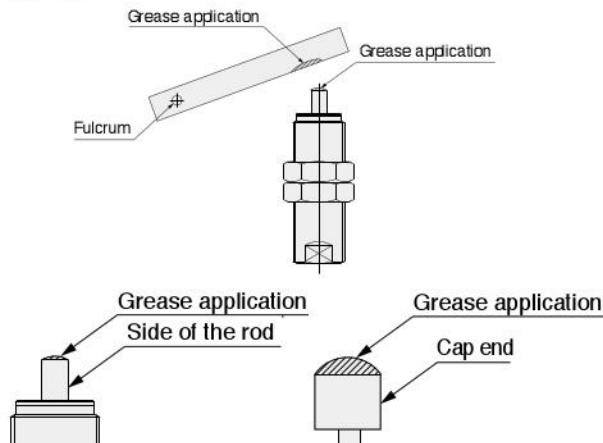

- * Grease application: Apply a small amount and spread it thinly.
- * Wipe off the grease if it gets stuck to the cap end or the side of the rod.
- * If grease gets inside the body of the shock absorber and excessively increases its inner volume, the pressure inside the shock absorber will rise when absorbing an impact and cause damage due to the plug popping out, or other similar situations. Make sure not to apply grease excessively.

3. Ensure that the hardness of the surface directly impacting the piston rod of the shock absorber is over HRC40 hardness (excluding models with cap). We also recommend a surface roughness of Ry6.3 or less.

4. Angle of eccentricity specification shock absorbers can be used very effectively if they are mounted at a position far from the center of rotation. However, use shock absorbers with a thrust stronger than the returning force of the spring (return force of the piston rod).

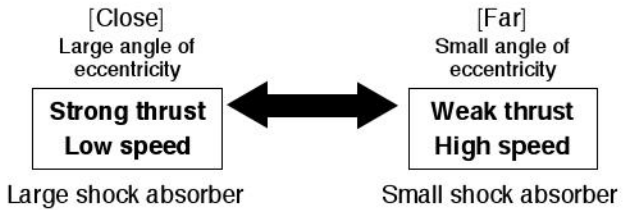

5. Two or more shock absorbers can be mounted in parallel, to boost absorption capacity. However, keep the distances from the center of rotation to each shock absorber equal. Also, have the load applied evenly between each shock absorber.

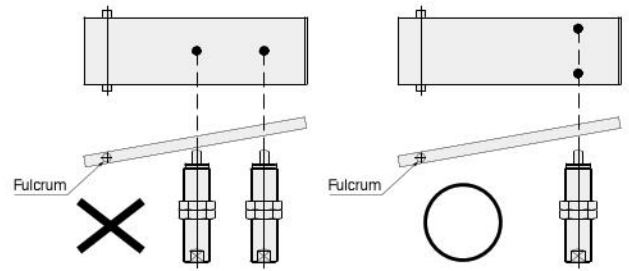

6. To adjust the capacity with the stroke, adjust the stopper nut (-S) or add an external stopper.
7. If using with a cap, always mount a stopper nut (-S) or an external stopper to ensure that the cap is not subjected to loads at the stroke end. Install the mounting position of the stopper nut such that $A \leq$ the stroke of the shock absorber. You can use it without a stopper nut or external stopper, but over the long-term, the stop location changes due to cap deformation and wear.

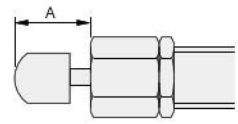

8. The small screw on the back end of the shock absorber should never be loosened or removed. Oil may leak out of the shock absorber leading to a loss of functionality and resulting in damage to the equipment and accidents.
9. When mounting the shock absorber, always use the following maximum tightening torque guidelines. Tightening using excessive force may result in damage.

Model	Maximum tightening torque
KSHY6 × 4 (C)-01,-02	0.85
KSHY8 × 5 (C)-01,-02,-11,-12	2.5
KSHY10 × 6 (C)-01,02	6.5
KSHY12 × 6 (C)-01,02	8.0
KSHY14 × 8 (C)-01,02	12.0
KSHY16 × 8 (C)-01,02	20.0
KSHY20 × 10 (C)-01,02	30.0

10. Be aware that performance and characteristics change depending on the operating temperature.

Selection guidelines

How to select durable angle of eccentricity shock absorbers

1. Confirm the thrust
Choose a shock absorber from its allowable thrust.
2. Confirm the angle of eccentricity
Confirm that the shock absorber selected in step 1 can be used under the allowable angle of eccentricity.
3. Confirm the absorption capacity
Confirm that the absorption capacity of the shock absorber is sufficient.
 - 3-1. Confirm the impact speed
 - 3-2. Confirm the absorption capacity of the shock absorber
 - 3-3. Calculate the moment of inertia
 - 3-4. Calculate the kinetic energy
4. Confirm other specifications
Confirm any specifications other than the angle of eccentricity and absorption capacity.

1. Confirm the thrust

The thrust that is applied to the shock absorber (F) should be weaker than the allowable thrust. If a thrust stronger than the allowable thrust is used, the shock absorber may be damaged in fewer operation cycles than the guaranteed life. See page 33 for the values of allowable thrust.

When using an rotating actuator

$$F = T \div R$$

T: Torque of the rotating actuator [N·m]

R: Shock absorber's mounting radius (the distance from the center of rotation to the shock absorber) [m]

F: Force at the point of distance Rm (thrust applied to the shock absorber) [N]

When using a linear actuator

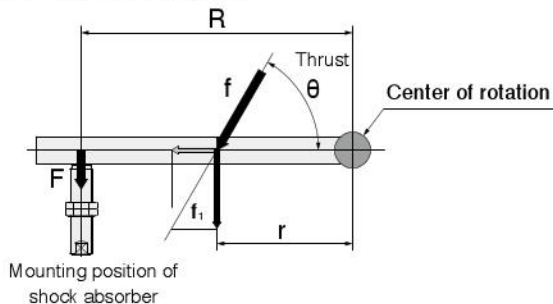

$$f_1 = f \times \sin \theta$$

$$T = f_1 \times r = F \times R$$

$$F = (f \times \sin \theta \times r) \div R$$

f : Thrust of linear actuator [N]

f₁ : Force acting on the direction of rotation [N]

r : Mounting position of actuator's end [m]

If the value for F is greater than the allowable thrust, do the following countermeasures.

- Use a larger size shock absorber
- Make R, the mounting radius, larger

2. Confirm the angle of eccentricity

Confirm whether the approximate value for angle of eccentricity of the prospective shock absorbers may be less than 10°. Finally, you should check on the device's drawings since, in actuality, the angles for even the same radii may differ, depending on the shapes and the mounting methods.

If a workpiece is installed so that it contacts the plug of the shock absorber, in parallel, at the stroke end, its approximate angle of eccentricity and minimum mounting radius are as follows.

These are not the actual values because the rotating parts have some thickness.

These are reference values for when you are making a selection.

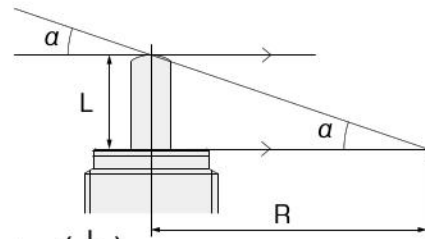

$$10^\circ \geq \alpha = \tan^{-1}\left(\frac{L}{R}\right)$$

L: Shock absorber's stroke [mm]

R: Shock absorber's mounting radius [mm]

α: Deflection angle [°]

Model	Stroke[mm]	Allowable angle of eccentricity	Minimum mounting radius [mm]
KSHY6 × 4 (C)	4	10° or less	22.7
KSHY8 × 5 (C)	5		28.4
KSHY10 × 6 (C)	6		34
KSHY12 × 6 (C)			
KSHY14 × 8 (C)	8		45.4
KSHY16 × 8 (C)			
KSHY20 × 10 (C)	10	56.7	

If the allowable angle of eccentricity is exceeded, do the following countermeasures, and then do [1. Confirm the thrust] again.

- Make R, the mounting radius, larger
- Use a smaller size shock absorber

Continue on the next page →

3. Confirm the absorption capacity
4. Confirm other specifications

Selection guidelines

3. Confirm the absorption capacity

3-1. Confirm the impact speed

$$\text{Angular velocity } \omega \text{ [rad/s]} = \frac{\text{Swing angle [rad]}}{\text{Target swing time [s]}} \times 2^{\text{Note}}$$

$$\text{Swing angle [}^\circ\text{]} \times \pi \div 180 = \text{Swing angle [rad]} \quad (90^\circ \doteq 1.57\text{rad})$$

Velocity at the shock absorber's mounting position

$$V[\text{m/s}] = R \times \omega \leq \text{Maximum impact speed (1 m/s)}$$

Note: Because the impact speed, not the average speed, is needed, calculate with twice the value of this.

3-2. Confirm the absorption capacity of the shock absorber

If you are using the impact speed, V, found in step 3-1, confirm the exhibited absorption capacity of the shock absorber (e.g. [J]) on the selection graph on page 40. The maximum absorption capacity is reached only when used at the maximum impact speed. The absorption capacity of the shock absorber changes, depending on the operating speed, because the drag of the oil is strong when the flow rate is fast and weak when the flow rate is slow.

3-3. Calculate the moment of inertia

Find the moment of inertia for the impact object I [kg·m²] to calculate the kinetic energy. If the impact object is rotating, you cannot make a selection by only using the impact object mass because the kinetic energy differs depending on the shape, even if the weight is the same. Calculate the approximate value by referring to the diagram for calculating the moment of inertia (pages 41 to 42).

3-4. Calculate the kinetic energy

Confirm that the kinetic energy of the impact object is less than the absorption capacity of the shock absorber.

$$\text{Kinetic energy of the impact object } E \text{ [J]} = \frac{1}{2} I \omega^2 \leq E_x$$

Calculating the thrust energy is not necessary because the shock absorber was selected from the allowable thrust in step 1. Assume that the absorption capacity = the allowable kinetic energy.

4. Confirm other specifications

Confirm such specifications as the maximum operating frequency, maximum absorption per unit of time, and operating temperature range.

Selection guidelines

Example selection 1: Using a rotary actuator

<Operating conditions>

When the impact object is a rod

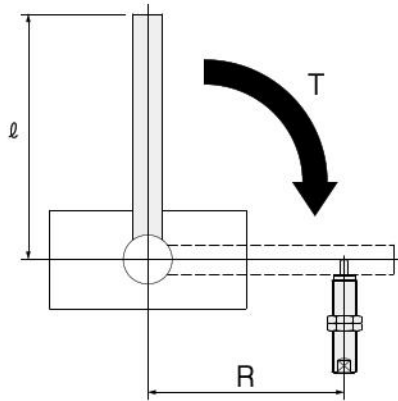

- ① Torque of rotating actuator: $T = 5[\text{N}\cdot\text{m}]$
- ② Absorber's mounting radius: $R = 50[\text{mm}] = 0.05[\text{m}]$
- ③ Impact object mass: $m = 3[\text{kg}]$
- ④ Length from the center of rotation to the end of the rod:
 $l = 120[\text{mm}] = 0.12[\text{m}]$
- ⑤ Angle of rotation: 90°
- ⑥ Target swing time: $0.5[\text{s}]$

1. Confirm the thrust

Find the thrust, F , that is applied to the shock absorber.

$$F = T \div R$$

$$= ① 5[\text{N}\cdot\text{m}] \div ② 0.05[\text{m}]$$

$$= 100[\text{N}]$$

Make a selection from a model (KSHY10 or higher) for an allowable thrust of 100 N or more.
(Refer to page 48 for specifications.)

2. Confirm the angle of eccentricity

Confirm whether the angle of eccentricity is less than the allowable angle of eccentricity (10°).

Assume that KSHY10×6 (body thread size: M10, stroke: 6 mm) is used.

$$\alpha = \tan^{-1}\left(\frac{L}{R}\right)$$

$$= \tan^{-1}\left(\frac{6[\text{mm}]}{② 50[\text{mm}]}\right)$$

$$\doteq 6.84^\circ < 10^\circ$$

3. Confirm the absorption capacity

3-1. Confirm the impact speed

Calculate the velocity at which the impact object impacts the shock absorber.

Swing angle $[\circ] \times \pi \div 180 =$ Swing angle [rad]

$$⑤ 90[\circ] \times \pi \div 180 \doteq 1.57\text{rad}$$

Angular velocity ω [rad/sec] = $\frac{\text{Swing angle [rad]}}{\text{Target swing time [s]}} \times 2$

$$\omega = \frac{1.57[\text{rad}]}{⑥ 0.5[\text{s}]} \times 2$$

$$\doteq 6.28[\text{rad/s}]$$

Velocity, V , of the shock absorber's mounting position [m/s]

$$= R \times \omega$$

$$V = ② 0.05[\text{m}] \times 6.28[\text{rad/s}]$$

$$\doteq 0.31[\text{m/s}] < 1\text{m/s}$$

3-2. Confirm the absorption capacity of the shock absorber

Assume that you selected $V = 0.31$ m/s from the selection graph on page 49 and confirm the absorption capacity, E_x , that KSHY10×6 exhibits.

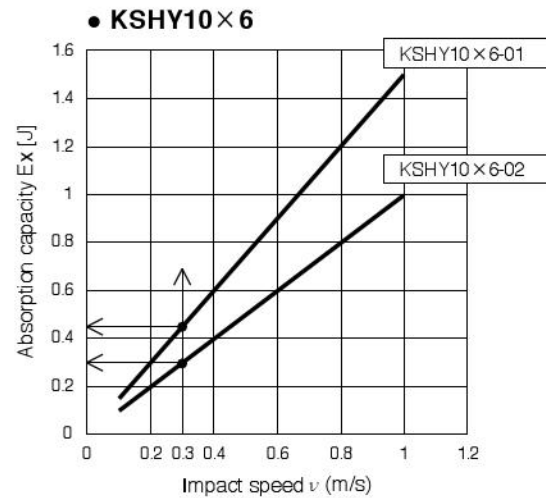

Values for E_x :

KSHY10×6-01: Approx. 0.45 J

KSHY10×6-02: Approx. 0.3 J

3-3. Calculate the moment of inertia

Find the moment of inertia for the impact object I [$\text{kg}\cdot\text{m}^2$] to calculate the kinetic energy.

According to "Rod (end is the center of rotation)", the diagram for calculating the moment of inertia (pages 41 to 42):

$$I = \frac{m l^2}{3}$$

$$= \frac{③ 3[\text{kg}] \times ④ 0.12[\text{m}]^2}{3}$$

$$= 0.0144[\text{kg}\cdot\text{m}^2]$$

3-4. Calculate the kinetic energy

Calculate the kinetic energy of the impact object to confirm whether it is less than the absorption capacity of the shock absorber.

$$\text{Kinetic energy of the impact object } E [\text{J}] = \frac{1}{2} I \omega^2$$

$$E = \frac{1}{2} \times 0.0144[\text{kg}\cdot\text{m}^2] \times (6.28[\text{rad/s}])^2$$

$$= 0.28[\text{J}]$$

Values for E_x found in step 3-2:

KSHY10×6-01: Approx. 0.45 J

KSHY10×6-02: Approx. 0.3 J

The shock absorber with the optimum absorption capacity is KSHY10×6-02 because the smaller the gap between the values for E and E_x is, the lower the impact value and the shorter the operating time.

4. Confirm other specifications

Confirm that other operating conditions, such as the maximum operating frequency, maximum absorption capacity per unit of time, and operating temperature range, are within the specified ranges for KSHY10×6-02.

Selection guidelines

Example selection 2: Using an air cylinder

<Operating conditions>

When the impact object is a rod

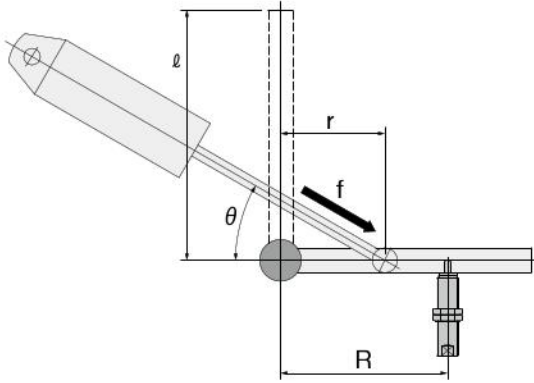

- ① Cylinder thrust: $\Phi 32(0.5\text{MPa}) \rightarrow 402[\text{N}]$
- ② Cylinder thrust angle: $\theta = 30^\circ$
- ③ Mounting position of cylinder's end: $r = 30[\text{mm}] = 0.03[\text{m}]$
- ④ Absorber's mounting radius: $R = 50[\text{mm}] = 0.05[\text{m}]$
- ⑤ Impact object mass: $m = 3[\text{kg}]$
- ⑥ Length from the center of rotation to the end of the rod: $l = 120[\text{mm}] = 0.12[\text{m}]$
- ⑦ Swing angle: 90°
- ⑧ Target swing time: $0.5[\text{s}]$

1. Confirm the thrust

Find the thrust, F , that is applied to the shock absorber.

$$F = (f \times \sin \theta \times r) \div R$$

$$= ① 402[\text{N}] \times ② \sin 30^\circ \times ③ 0.03[\text{m}] \div ④ 0.05[\text{m}]$$

$$= 120.6[\text{N}]$$

Make a selection from a model (KSHY12 or higher) for an allowable thrust of 120.6 N or more.

(Refer to page 49 for specifications.)

2. Confirm the angle of eccentricity

Confirm whether the angle of eccentricity is less than the allowable angle of eccentricity (10°).

Assume that KSHY12×6 (body thread size: M12, stroke: 6 mm) is used.

$$\alpha = \tan^{-1}\left(\frac{L}{R}\right)$$

$$= \tan^{-1}\left(\frac{⑥ 6[\text{mm}]}{④ 50[\text{mm}]}\right)$$

$$\doteq 6.84^\circ < 10^\circ$$

3. Confirm the absorption capacity

3-1. Confirm the impact speed

Calculate the velocity at which the impact object impacts the shock absorber.

Swing angle $[\circ] \times \pi \div 180 =$ Swing angle [rad]

$$⑦ 90[\circ] \times \pi \div 180 \doteq 1.57\text{rad}$$

Angular velocity ω [rad/sec] = $\frac{\text{Swing angle [rad]}}{\text{Target swing time [s]}} \times 2$

$$\omega = \frac{1.57[\text{rad}]}{⑧ 0.5[\text{s}]} \times 2$$

$$\doteq 6.28[\text{rad/s}]$$

Velocity, V , of the shock absorber's mounting position [m/s]

$$= R \times \omega$$

$$V = ④ 0.05[\text{m}] \times 6.28[\text{rad/s}]$$

$$\doteq 0.31[\text{m/s}] < 1\text{m/s}$$

3-2. Confirm the absorption capacity of the shock absorber

From the selection graph on page 40:

Assume that you selected $V = 0.31$ m/s and confirm the absorption capacity, E_x , that KSHY12×6 exhibits.

● KSHY12×6

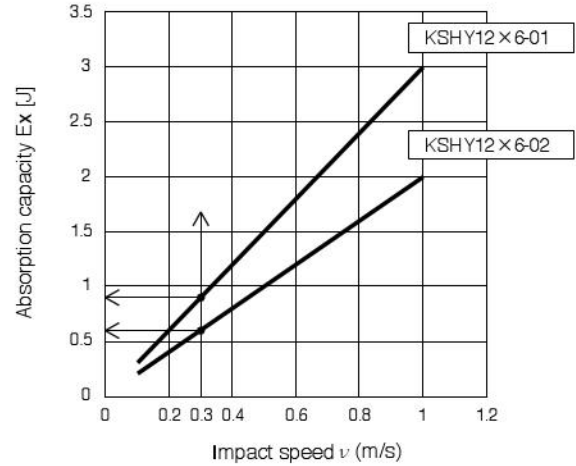

Values for E_x :

KSHY12×6-01: Approx. 0.9 J

KSHY12×6-02: Approx. 0.6 J

3-3. Calculate the moment of inertia

Find the moment of inertia for the impact object I [$\text{kg} \cdot \text{m}^2$] to calculate the kinetic energy.

According to "Rod (end is the center of rotation)", the diagram for calculating the moment of inertia (pages 41 to 42):

$$I = \frac{m \ell^2}{3}$$

$$= \frac{⑤ 3[\text{kg}] \times ⑥ 0.12[\text{m}]^2}{3}$$

$$= 0.144[\text{kg} \cdot \text{m}^2]$$

3-4. Calculate the kinetic energy

Calculate the kinetic energy of the impact object to confirm whether it is less than the absorption capacity of the shock absorber.

Kinetic energy of the impact object E [J] = $\frac{1}{2} I \omega^2$

$$E = \frac{1}{2} \times 0.144[\text{kg} \cdot \text{m}^2] \times 6.28[\text{rad/s}]^2$$

$$= 0.28[\text{J}]$$

Values for E_x found in step 3-2:

KSHY12×6-01: Approx. 0.9 J

KSHY12×6-02: Approx. 0.6 J

The shock absorber with the optimum absorption capacity is KSHY12×6-02 because the smaller the gap between the values for E and E_x is, the lower the impact value and the shorter the operating time.

4. Confirm other specifications

Confirm that other operating conditions, such as the maximum operating frequency, maximum absorption capacity per unit of time, and operating temperature range, are within the specified ranges for KSHY12×6-02.

Selection guidelines

Cautions for using the selection graphs

1. Use with an absorption capacity below the capacity curves.
2. The values in the selection graphs are for room temperature (20 to 25°). Be aware that performance and characteristics change depending on the operating temperature.

■ Selection graph

● KSHY6×4

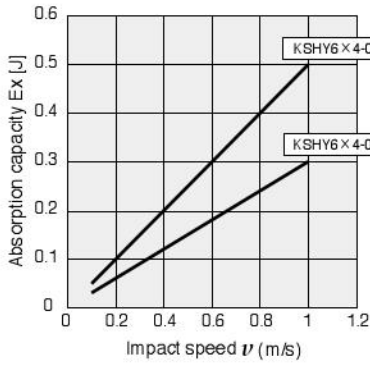

● KSHY8×5

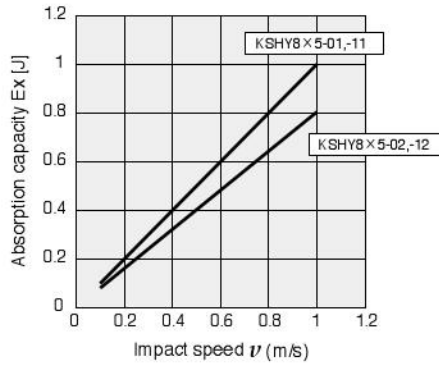

● KSHY10×6

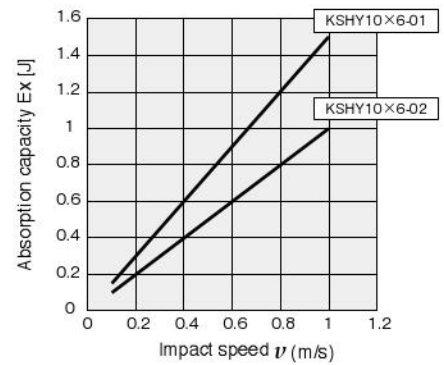

● KSHY12×6

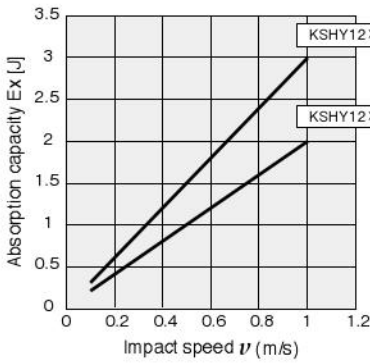

● KSHY14×8

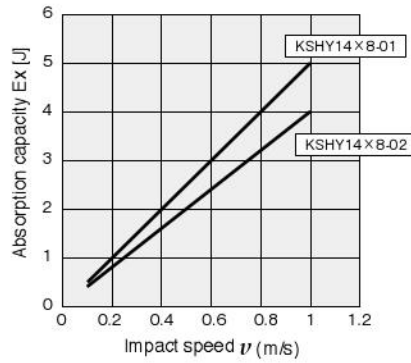

● KSHY16×8

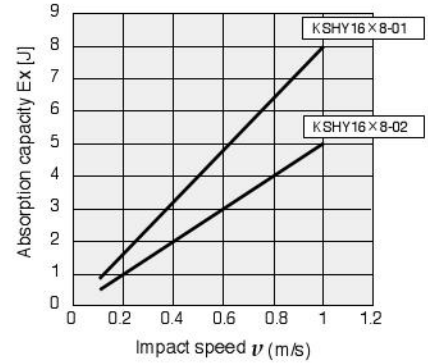

● KSHY20×10

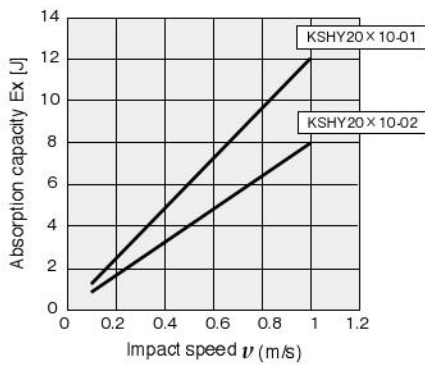

Selection guidelines

■ Diagram for calculating the moment of inertia

[When the rotation axis goes through the workpiece]

● Disk

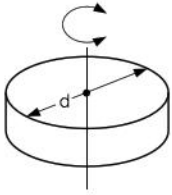

- Diameter
- Mass

d (m)
m (kg)

■ Moment of inertia I [kg·m²]

$$I = \frac{md^2}{8}$$

● Stepped disk

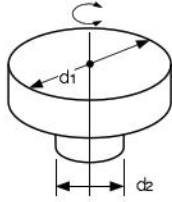

- Diameter
 - Mass
- d₁ (m)
d₂ (m)
d₁ part m₁ (kg)
d₂ part m₂ (kg)

■ Moment of inertia I [kg·m²]

$$I = \frac{1}{8} (m_1 d_1^2 + m_2 d_2^2)$$

■ Radius of rotation

$$\frac{d_1^2 + d_2^2}{8}$$

Remark: The d₂ part can be ignored if it is much smaller compared to the d₁ part.

● Rod (end is the center of rotation)

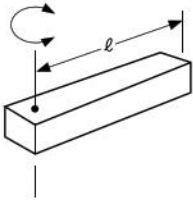

- Rod length
 - Mass
- l (m)
m (kg)

■ Moment of inertia I [kg·m²]

$$I = \frac{ml^2}{3}$$

● Fine rod

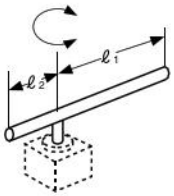

- Rod length
 - Mass
- l₁ (m)
l₂ (m)
m₁ (kg)
m₂ (kg)

■ Moment of inertia I [kg·m²]

$$I = \frac{m_1 l_1^2}{3} + \frac{m_2 l_2^2}{3}$$

● Rod (center of gravity is the center of rotation)

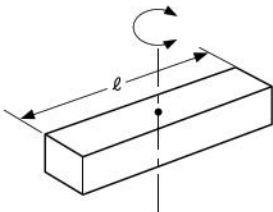

- Rod length
 - Mass
- l (m)
m (kg)

■ Moment of inertia I [kg·m²]

$$I = \frac{ml^2}{12}$$

● Thin, rectangular plate (rectangular parallelepiped)

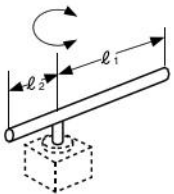

- Plate length
 - Edge length
 - Mass
- a₁ (m)
a₂ (m)
b (m)
m₁ (kg)
m₂ (kg)

■ Moment of inertia I [kg·m²]

$$I = \frac{m_1}{12} (4a_1^2 + b^2) + \frac{m_2}{12} (4a_2^2 + b^2)$$

● Rectangular parallelepiped

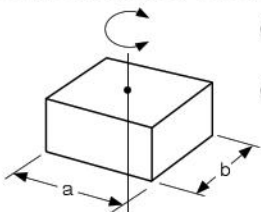

- Edge length
 - Mass
- a (m)
b (m)
m (kg)

■ Moment of inertia I [kg·m²]

$$I = \frac{m}{12} (a^2 + b^2)$$

Selection guidelines

● Concentrated load

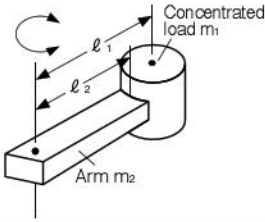

- Shape of concentrated load
- Length to the concentrated load's center of gravity
- Arm length
- Mass of the concentrated load
- Mass of the arm

l_1 (m)
 l_2 (m)
 m_1 (kg)
 m_2 (kg)

■ Moment of inertia I [kg·m²]

$$I = m_1 k^2 + m_1 l_1^2 + \frac{m_2 l_2^2}{3}$$

Radius of rotation: k^2 is calculated according to the shape of the concentrated load.
 Remark: When m_2 is much smaller compared to m_1 , it is okay to calculate $m_2 = 0$.

[When the rotation axis is off set from the workpiece]

● Rectangular parallelepiped

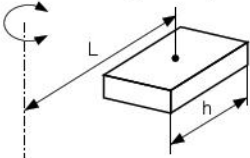

- Edge length
- Distance from the rotation axis to the center of the load
- Mass

h (m)
 L (m)
 m (kg)

■ Moment of inertia I [kg·m²]

$$I = \frac{mh^2}{12} + mL^2$$

Remark: Same as for cube

● Hollow rectangular parallelepiped

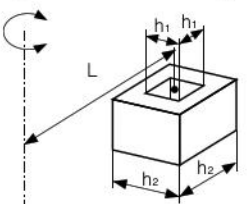

- Edge length
- Distance from the rotation axis to the center of the load
- Mass

h_1 (m)
 h_2 (m)
 L (m)
 m (kg)

■ Moment of inertia I [kg·m²]

$$I = \frac{m}{12}(h_2^2 + h_1^2) + mL^2$$

Remark: Cross-section is a cube only

● Cylinder

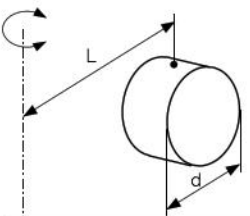

- Diameter
- Distance from the rotation axis to the center of the load
- Mass

d (m)
 L (m)
 m (kg)

■ Moment of inertia I [kg·m²]

$$I = \frac{md^2}{16} + mL^2$$

● Hollow cylinder

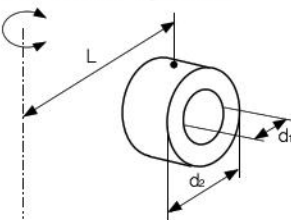

- Diameter
- Distance from the rotation axis to the center of the load
- Mass

d_1 (m)
 d_2 (m)
 L (m)
 m (kg)

■ Moment of inertia I [kg·m²]

$$I = \frac{m}{16}(d_2^2 + d_1^2) + mL^2$$

Linear orifice shock absorber

KSHY Series



Specifications

Item	Model	KSHY6×4-01	KSHY6×4-02	KSHY8×5-01,-11	KSHY8×5-02,-12
Maximum absorption capacity	J	0.5	0.3	1	0.8
Stroke	mm	4		5	
Impact speed range	m/s	0.1 to 1.0			
Allowable thrust		27.5N or less		60.3N or less	
Maximum operating cycle	cycle/min	60			
Maximum absorption capacity per unit of time	J/min	18		36	
Spring return force ^{Note1}	N	3.5		6.5	
Deflection angle		10° or less			
Operating temperature range ^{Note2}	°C	0 to 60			

Item	Model	KSHY10×6-01	KSHY10×6-02	KSHY12×6-01	KSHY12×6-02
Maximum absorption capacity	J	1.5	1	3	2
Stroke	mm	6			
Impact speed range	m/s	0.1 to 1.0			
Allowable thrust		100N or less		157N or less	
Maximum operating cycle	cycle/min	60			
Maximum absorption capacity per unit of time	J/min	45		80	
Spring return force ^{Note1}	N	8.5		15.5	
Deflection angle		10° or less			
Operating temperature range ^{Note2}	°C	0 to 60			

Item	Model	KSHY14×8-01	KSHY14×8-02	KSHY16×8-01	KSHY16×8-02	KSHY20×10-01	KSHY20×10-02
Maximum absorption capacity	J	5	4	8	5	12	8
Stroke	mm	8		8		10	
Impact speed range	m/s	0.1 to 1.0					
Allowable thrust		245N or less		402N or less		628N or less	
Maximum operating cycle	cycle/min	60		40			
Maximum absorption capacity per unit of time	J/min	100		130		200	
Spring return force ^{Note1}	N	14.5		14.5		21.5	
Deflection angle		10° or less					
Operating temperature range ^{Note2}	°C	0 to 60					

Note 1: The spring return force cannot be used as a function because it is the return force of the piston rod at full stroke, making it unstable.

Note2: The shock absorbing capacity fluctuates based on speed and ambient temperature. Always use a product that is within the range shown by the solid lines in the graphs on pages 40.

Mass

Model	Body ^{Note}	Additional parts' mass			
		Additional mass With plastic cap	Mounting nut (1 ea.)	Stopper nut	Side mounting bracket
KSHY6×4-01, -02	4.5	0.2	0.4	3	8
KSHY8×5-01, -11	9	0.4	0.6(0.9)	4	12
KSHY10×6-01, -02	20.1	0.8	1.2	7	15
KSHY12×6-01, 02	32	1.3	1.9	8	22
KSHY14×8-01, 02	53	2.3	4	15	41
KSHY16×8-01, -02	70	2.3	6.6	28	65
KSHY20×10-01, -02	129	5	12.2	55	110

Calculation example: The mass of KSHY10×6C-01-S-2 (with cap, stopper, and side mount) is
 $20 + 1.3 + 7 + 15 = 43.3\text{g}$

Note: The weight of the main unit includes the weight of 2 mounting nuts.

Inner Construction and Major Parts and Materials

●KSHY6×4

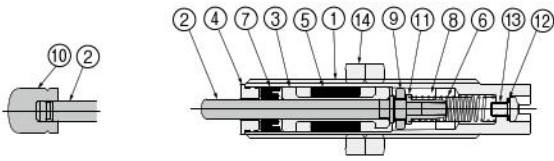

●KSHY8 to 20

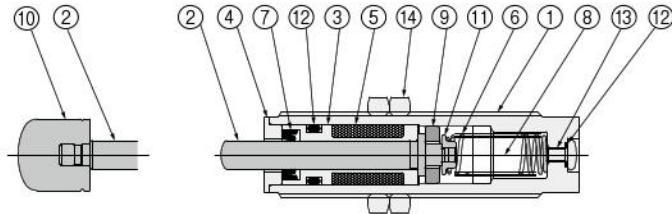

No.	Name	Materials
①	Body ^{Note 1}	Copper alloy (nickel plated)
②	Piston rod ^{Note 2}	Stainless steel,
③	Sleeve	Copper alloy
④	Plug	Stainless steel
⑤	Accumulator	Synthetic rubber
⑥	Spring	Spring steel
⑦	Rod seal	Synthetic rubber
⑧	Oil	Special oil
⑨	Piston ring	Stainless steel,
⑩	Cap	Plastic (POM)
⑪	Collar ^{Note 3}	Stainless steel,
⑫	O-ring	Synthetic rubber
⑬	Screw ^{Note 4}	Mild steel (zinc plated)
⑭	Mounting nut	Mild steel (nickel plated)

Note1: KSHY6 and 8 are stainless steel
 Note2: Shock absorbers with no caps undergo a quenching treatment.
 Note3: KSHY6 and 8 are copper alloy
 KSHY10 and 12 are sintered metal
 Note4: KSHY6 and 8 are nickel plated

Order Codes

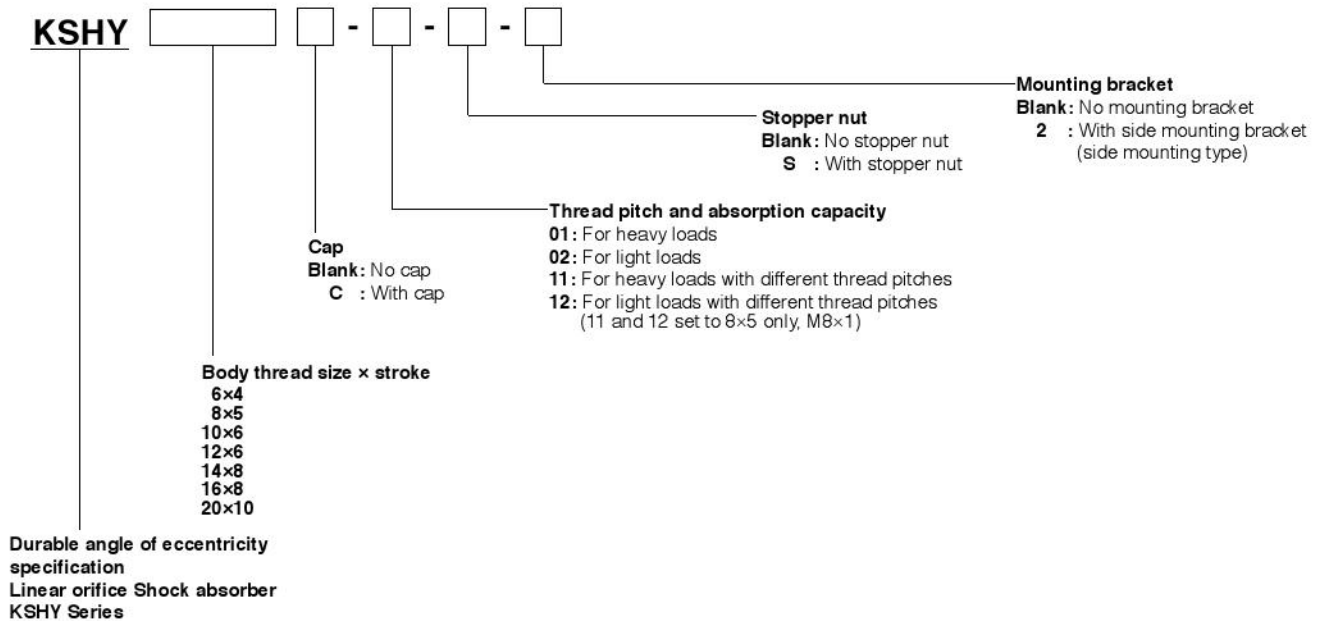

Additional Parts

●Mounting nut (1 pack has 10 units)

N - KSH - M []



Thread size
 6: KSHY6
 8: KSHY8
 8-11: KSHY8-11
 10: KSHY10
 12: KSHY12
 14: KSHY14
 16: KSHY16
 20: KSHY20

●Stopper nut

S - KSH - M []



Thread size
 6-L: KSHY6
 8: KSHY8
 8-11: KSHY8-11
 10: KSHY10
 12: KSHY12
 14: KSHY14
 16: KSHY16
 20: KSHY20

●Side mounting bracket

2 - KSH - M []



Thread size
 6: KSHY6
 8: KSHY8
 8-11: KSHY8-11
 10: KSHY10
 12: KSHY12
 14: KSHY14
 16: KSHY16
 20: KSHY20

* For the dimension diagrams of the additional parts, see pages 72 to 73.

* The stopper nut and side mount are made from mild steel (nickel plated).

Dimensions (mm)

•KSHY6×4-□

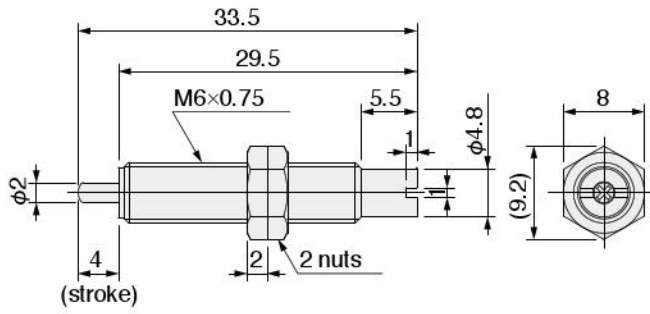

•KSHY6×4C-□

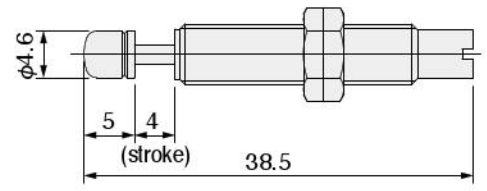

•KSHY8 to 20

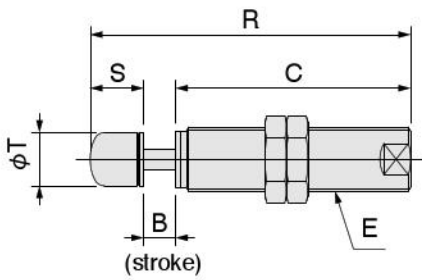
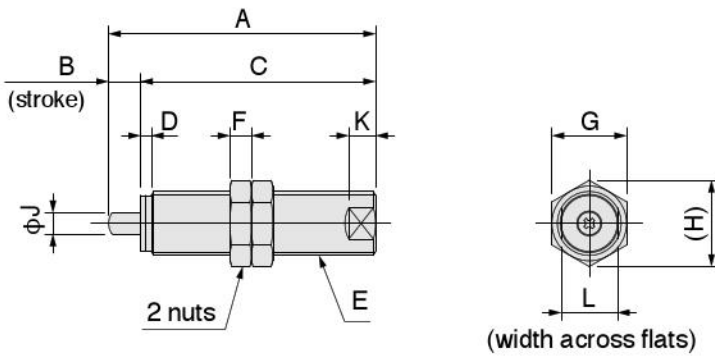

Model	Symbol	A	B	C	D	E	F	G	H	J	K	L	R	S	T
KSHY8 × 5 (C)-01,-02		36	5	31	1.2	M8 × 0.75	2	10	11.5	2.5	3	7	42	6	6.5
KSHY8 × 5 (C)-11,-12		36	5	31	1.2	M8 × 1	3	10	11.5	2.5	3	7	42	6	6.5
KSHY10 × 6 (C)-01,-02		46	6	40	2	M10 × 1	3	12	13.9	3	5	8.5	55	9	8
KSHY12 × 6 (C)-01,-02		50	6	44	2	M12 × 1	4	14	16.2	4	5	10.5	60	10	10
KSHY14 × 8 (C)-01,-02		61	8	53	2	M14 × 1.5	5	17	19.6	5	5	12	72	11	11
KSHY16 × 8 (C)-01,-02		61	8	53	3	M16 × 1.5	7	19	21.9	5	7	13	72	11	11
KSHY20 × 10 (C)-01,-02		69	10	59	3	M20 × 1.5	8	24	27.7	6	7	17	84	15	15

Adjustment Type Linear Orifice[®] Shock Absorber KSHP Series

Introducing the **adjustable** linear orifice!
Long **3 million cycle** operating life! (M42 Exc.)
Uses NSF certified **H1 oil** (non silicon)



KSHJ

KSHY

KSHP

KSHC

Additional Parts

Handling Instructions and Precautions



General precautions

Cover the unit when mounting it in locations where it might be subject to excessive dust, dripping water, dripping oil, etc. Dents, scratches, water, oil, or dust on the piston rod results in damage and decreases service life.



Mounting

1. Keep the angle of eccentricity, resulting from the load direction and the axis of the shock absorber, under the specified values on page 5. If an eccentric load exceeding the specifications is applied, it could result in breakage or impaired returns. If there is concern that an eccentric load exceeding the specified values will be applied, install a guide, or similar mechanism.
2. You cannot mount two or more adjustable type shock absorbers in parallel to boost the absorption capacity (it is difficult to adjust the capacity evenly).
3. If using a shock absorber with a plastic or rubber cap, always mount a stopper nut (-S) or an external stopper to ensure that the cap is not subjected to loads at the stroke end. Install the stopper nut in a position such that $A \leq$ the stroke of the shock absorber. Furthermore, you can use a shock absorber that has a plastic cap without a stopper nut (-S) or external stopper, but, over the long-term, the stop location will change due to cap deformation and wear.

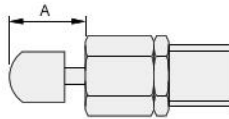

4. Rubber caps are consumable parts. The service life will vary depending on conditions of the application, replace these parts according to their condition.
5. If using a shock absorber with a rubber cap for lateral impacts, such as eccentric or swing impacts, note that the rubber cap may come off or be damaged.
6. When mounting the shock absorber, always use the following maximum tightening torque guidelines. Tightening using excessive force may result in damage.

Model	Maximum tightening torque	
	N · m	in · lbf
KSHP6 × 4 (C)(-F11)	0.85	7.523
KSHP8 × 6 (C)(-11)(-F11)	2.5	22.128
KSHP10 × 8 (C)(-F11)	6.5	57.532
KSHP11 × 8 (C)-F11	—	57.5
KSHP12 × 10 (C,R)(-F11)	8.0	70.808
KSHP14 × 12 (C,R)(-F11)	12.0	106.2
KSHP16 × 15 (C,R)	20.0	—
KSHP18 × 20 (C,R)(-F11)	25.0	221.3
KSHP20 × 22 (C,R)	30.0	—
KSHP25 × 25 (C,R)(-F11)	42.0	371.7
KSHP30 × 30 (C,R)(-F11)	60.0	531.1
KSHP36 × 50 (C,R)(-F11)	72.0	637.3
KSHP42 × 50 (C,R)(-F11)	85.0	752.3

7. Ensure that the hardness of the surface directly impacting the piston rod of the shock absorber is over HRc40 hardness (excluding models with rubber or plastic caps).
8. Be aware that performance and characteristics change depending on the operating temperature.



Adjusting the shock absorbing capacity

1. For the KSHP10 to KSHP42 models, align the red mark on the adjusting knob to the 6 on the scale. For the KSHP6 and KSHP8 models, align the 6 on the scale to the key slot on the body.
2. For large impacts on collision or if a long time is required for a full stroke, reduce the value on the scale gradually.
3. Always tighten the lock screw to fix the knob in place after completing adjustment. (excluding KSHP6 and KSHP8)

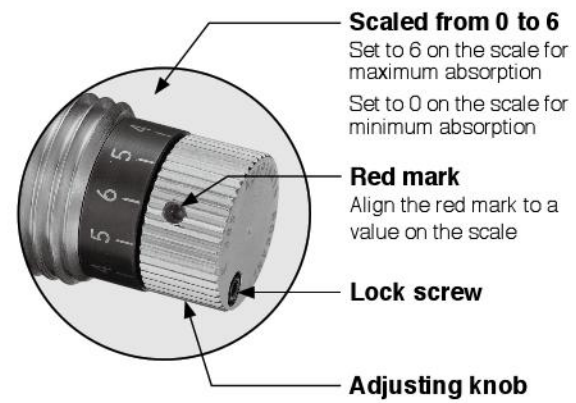

For KSHP6 and KSHP8

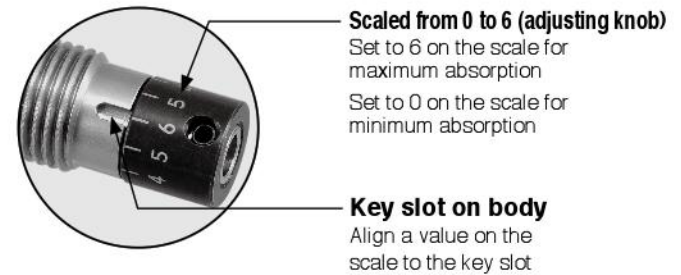

● Lock screw dimensions mm [in]

For KSHP 10 to 14

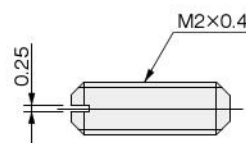

For KSHP 16 to 42

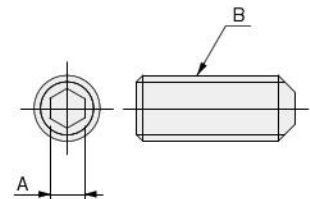

Model	Symbol	A	B
KSHP16 to 18		1.3	M2.5×0.45
KSHP20 to 42		1.5	M3×0.5

■ How to select shock absorbers

1. Confirm the thrust

Confirm the thrust that is used, and then check the prospective shock absorbers from the table of recommended cylinder bore sizes on page 48. If a shock absorber that is smaller than the recommended shock absorber is used, the shock absorber being used may be damaged in fewer operation cycles than is guaranteed.

2. Confirm the kinetic energy

Confirm I and II below, and then check page 48 for the selection graphs for prospective shock absorbers from [1. Confirm the thrust]. (*)

I Impact object mass: m [kg]

II Impact speed: v [m/s]

Because “ v ” is the impact speed, not the average speed, when using a cylinder,

$$v = m [\text{cylinder stroke}] \div s [\text{operating time}] \times 2$$

Select a model in which I and II fit within the range enclosed by the capacity curves.

If multiple models are applicable, use the model that is closest to both the capacity curves and the operating conditions. The further the model you select is from the capacity curves and the operating conditions, the slower it will tend to be.

3. Confirm other specifications

Confirm that such specifications as the maximum operating frequency, maximum absorption capacity per unit of time, angle of eccentricity, and operating temperature range are within the range for the shock absorber that you selected.

* The value for the kinetic energy, E , can be found by doing the following calculation. However, the shock absorber's capacity for absorption changes depending on the impact speed. When the shock absorber is doing low-speed operations, it has less drag than when it is doing high-speed operations.

The maximum absorption capacity that is noted in the specifications is reached only at the maximum impact speed.

Therefore, do not choose a shock absorber by comparing E to the maximum absorption capacity; confirm the capacity using the selection graph.

$$E = \frac{1}{2} mv^2$$

E : Kinetic energy (J)

m : Impact object mass [kg]

v : Impact speed (m/s)

Range in the selection graph

Vertical axis range :

$$\text{Maximum impact speed} \geq v \text{ Impact speed (operating condition)}$$

Horizontal axis range :

$$\text{Shock absorber's maximum absorption capacity at the impact speed (} v = \text{m/s)} \geq \frac{E}{\text{Kinetic energy (operating condition)}}$$

Calculating the thrust energy is not necessary because the size of the shock absorber is limited by the thrust in step 1.

■ Koganei's selectable content

You can also select equipment from Koganei's homepage.

Visit <http://www.koganei.co.jp>.

The results of selections using the method above may differ from the results of selections for the selectable content on our homepage. If this happens, please contact us.

■ Example of selecting a shock absorber

[Operating conditions]

① Bore size of the cylinder being used: $\phi 16$

② Cylinder stroke: 100 mm = 0.1 m

③ Pressure applied to the cylinder: 0.6 MPa

④ Cylinder's operating time: 0.4 s

⑤ Impact object mass: 10 kg

1. Confirm the thrust

Either calculate or find the thrust in the cylinder thrust table on page 48.

The cylinder thrust based on ① and ③ is about 121 N.

Cylinder thrust	100.5N	<	120.6N	<	126N
Cylinder bore size	$\phi 16$		$\phi 16$		$\phi 20$
Applied pressure	0.5MPa		0.6MPa		0.4MPa

As mentioned above, although the cylinder being used is $\phi 16$, the pressure applied to the cylinder exceeds 0.5 MPa, so consider the $\phi 20$ cylinder (lower than 0.4 MPa) and check the table of recommended cylinder bore sizes on page 48.

The following are prospective models.

- KSHP10×8
- KSHP12×10
- KSHP14×12
- KSHP16×15
- KSHP18×20
- KSHP20×22

2. Confirm the kinetic energy

I The impact object mass $m = 10$ kg from ⑤

II Find the impact speed, v , from ② and ④.

$$v = \frac{②}{④} = \frac{0.1 \text{ m}}{0.4 \text{ s}} \times 2 = 0.5 \text{ m/s}$$

According to the selection graphs on page 48, the shock absorber with the optimum absorption capacity for operating conditions is KSHP12×10.

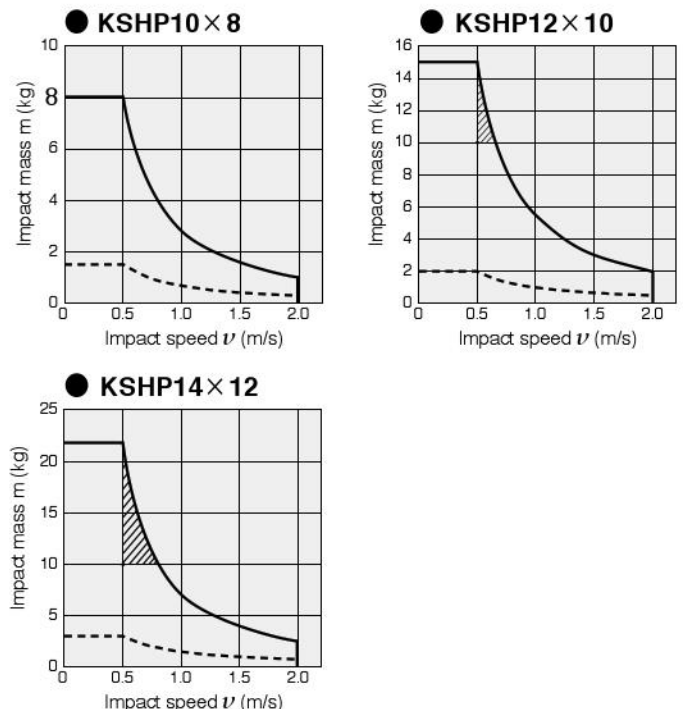

- KSHP10×8 has an insufficient absorption capacity.
- The absorption capacities for all of the other shock absorbers are higher than that of KSHP12×10, so they do not fall within the operating conditions and capacity curves.

3. Confirm other specifications

Verify that other operating conditions, such as the maximum operating frequency, maximum absorption capacity per unit of time, angle of eccentricity, and operating temperature range, are within the specified ranges for KSHP12×10.

Selection Guidelines

Recommended cylinder bore size

Model	Cylinder bore														
	φ4	φ6	φ8	φ10	φ12	φ16	φ20	φ25	φ32	φ40	φ50	φ63	φ80	φ100	φ125
KSHP6 × 4 (-F11)	◇	◇	○	○	○										
KSHP8 × 6 (-11)(-F11)		◇	◇	○	○	○									
KSHP10 × 8 (-F11)			◇	◇	○	○	○								
KSHP11 × 8-F11			◇	◇	○	○	○								
KSHP12 × 10 (-F11)				◇	◇	○	○	○							
KSHP14 × 12 (-F11)					◇	◇	○	○	○						
KSHP16 × 15						◇	◇	○	○	○					
KSHP18 × 20 (-F11)							◇	◇	○	○					
KSHP20 × 22							◇	◇	○	○	○				
KSHP25 × 25 (-F11)								◇	◇	○	○	○			
KSHP30 × 30 (-F11)									◇	◇	○	○	○		
KSHP36 × 50 (-F11)										◇	◇	○	○	○	
KSHP42 × 50 (-F11)											◇	◇	○	○	○

◇ : 0.3 MPa or higher ○ : 0.5 MPa or lower ○ : 0.4 MPa or lower

Note 1: If a shock absorber that is smaller than the recommended shock absorber is used, the shock absorber being used may be damaged in fewer operation cycles than the value that is guaranteed.

Note 2: KSHP11 × 8 has only inch specifications.

Cylinder thrust

N [lbf.]

Bore size mm [in.]	Pressure area mm ² [in. ²]	Air pressure MPa [psi.]									
		0.1 [15]	0.2 [29]	0.3 [44]	0.4 [58]	0.5 [73]	0.6 [87]	0.7 [102]	0.8 [116]	0.9 [131]	
φ4	12.6 [0.020]	1.3 [0.292]	2.5 [0.562]	3.8 [0.854]	5 [1.124]	6.3 [1.416]	7.5 [1.686]	8.8 [1.978]	10.1 [2.270]	11.3 [2.540]	
φ6	28.3 [0.044]	2.8 [0.629]	5.7 [1.281]	8.5 [1.911]	11.3 [2.540]	14.1 [3.170]	17.0 [3.822]	19.8 [4.451]	22.6 [5.080]	25.4 [5.710]	
φ8	50.3 [0.078]	5 [1.124]	10.1 [2.270]	15.1 [3.394]	20.1 [4.518]	25.1 [5.642]	30.2 [6.789]	35.2 [7.913]	40.2 [9.037]	45.2 [10.161]	
φ10	78.5 [0.122]	7.9 [1.776]	15.7 [3.529]	23.6 [5.305]	31.4 [7.059]	39.3 [8.835]	47.1 [10.588]	55 [12.364]	62.8 [14.117]	70.7 [15.893]	
φ12	113 [0.175]	11.3 [2.540]	22.6 [5.080]	33.9 [7.621]	45.2 [10.161]	56.5 [12.701]	67.9 [15.264]	79.2 [17.804]	90.5 [20.344]	101.8 [22.885]	
φ16	201 [0.312]	20.1 [4.518]	40.2 [9.037]	60.3 [13.555]	80.4 [18.074]	100.5 [22.592]	121 [27.201]	141 [31.697]	161 [36.193]	181 [40.689]	
φ20	314 [0.487]	31.4 [7.059]	62.8 [14.117]	94.2 [21.176]	126 [28.325]	157 [35.294]	188 [42.262]	220 [49.456]	251 [56.425]	283 [63.618]	
φ25	491 [0.761]	49.1 [11.038]	98.2 [22.075]	147 [33.046]	196 [44.061]	245 [55.076]	295 [66.316]	344 [77.331]	393 [88.346]	442 [99.362]	
φ32	804 [1.246]	80.4 [18.074]	161 [36.193]	241 [54.177]	322 [72.386]	402 [90.370]	483 [108.6]	563 [126.6]	643 [144.5]	724 [162.8]	
φ40	1257 [1.948]	126 [28.325]	251 [56.425]	377 [84.750]	503 [113.1]	628 [141.2]	754 [169.5]	880 [197.8]	1005 [225.9]	1131 [254.2]	
φ50	1963 [3.043]	196 [44.061]	393 [88.346]	589 [132.4]	785 [176.5]	982 [220.8]	1178 [264.8]	1374 [308.9]	1571 [353.2]	1767 [397.2]	
φ63	3117 [4.831]	312 [70.138]	623 [140.1]	935 [210.2]	1247 [280.3]	1559 [350.5]	1870 [420.4]	2182 [490.5]	2494 [560.7]	2806 [630.8]	
φ80	5027 [7.792]	503 [113.1]	1005 [225.9]	1508 [339.0]	2011 [452.1]	2513 [564.9]	3016 [678.0]	3519 [791.1]	4021 [903.9]	4524 [1017]	
φ100	7854 [12.174]	785 [176.5]	1571 [353.2]	2356 [529.6]	3142 [706.3]	3927 [882.8]	4712 [1059]	5498 [1236]	6283 [1412]	7069 [1589]	
φ125	12272 [19.022]	1227 [275.8]	2454 [551.7]	3682 [827.7]	4909 [1104]	6136 [1379]	7363 [1655]	8590 [1931]	9817 [2207]	11045 [2483]	

Selection Guidelines

Cautions for using the selection graphs

1. The selection graphs are calculated with a cylinder operating air pressure of 0.5 MPa.
2. The values in the selection graphs are for room temperature (20 to 25°C). Be aware that performance and characteristics change depending on the operating temperature.
3. Select a shock absorber that is as close to, yet within, the capacity line(s).
4. You can select them on the Koganei home page. Go to <http://www.koganei.co.jp>
The results of selections using our catalog may differ from the results of selections on our homepage.

Selection graph

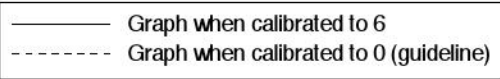

● **KSHP6 × 4 (-F11)**

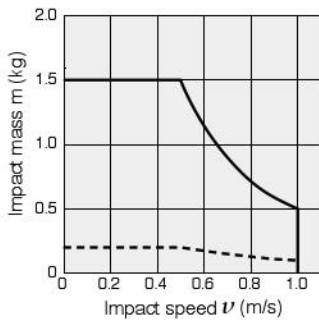

● **KSHP8 × 6 (-F11)**

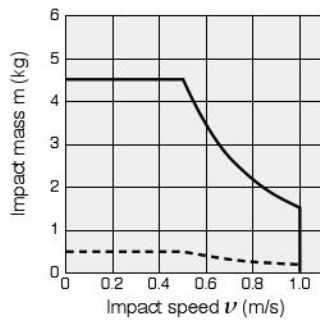

● **KSHP10 × 8 (-F11)**
● **KSHP11 × 8-F11**

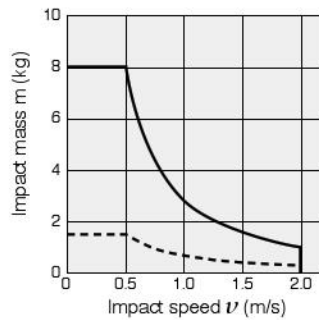

● **KSHP12 × 10 (-F11)**

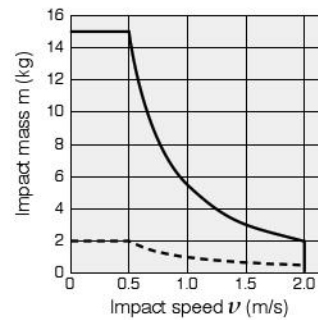

● **KSHP14 × 12 (-F11)**

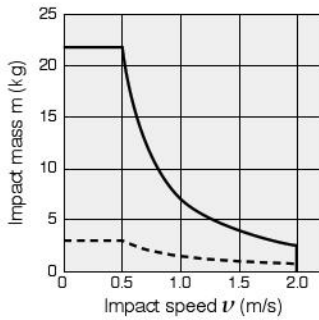

● **KSHP16 × 15**

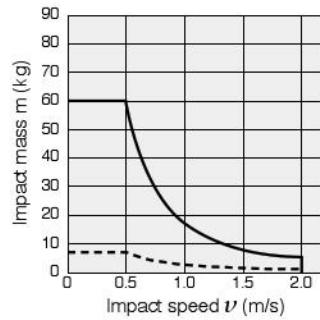

● **KSHP18 × 20 (-F11)**

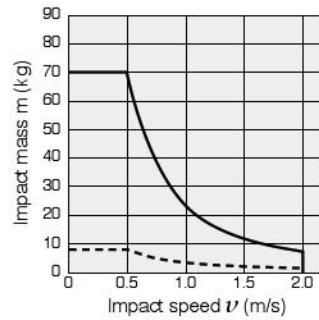

● **KSHP20 × 22**

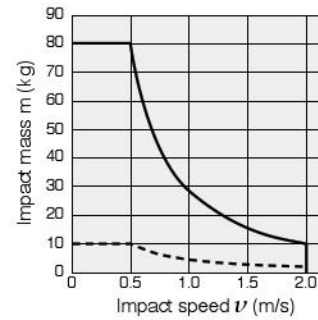

● **KSHP25 × 25 (-F11)**

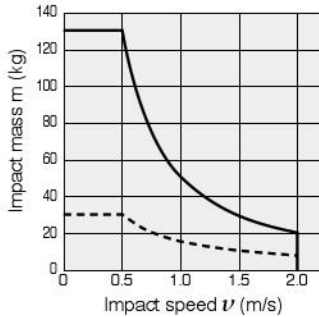

● **KSHP30 × 30 (-F11)**

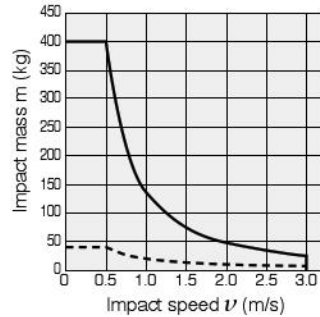

● **KSHP36 × 50 (-F11)**

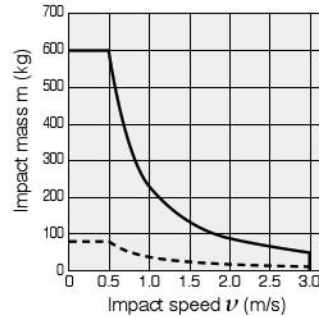

● **KSHP42 × 50-F11**

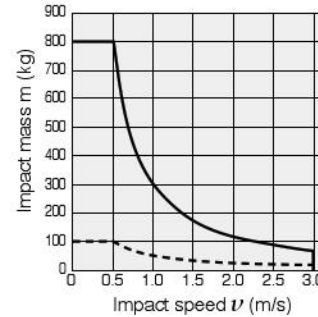

KSHJ

KSHY

KSHP

KSKC

Additional Parts

Linear orifice shock absorber

KSHP Series



Specifications

Item	Model (in inches)	KSHP6 × 4 (KSHP6 × 4-F11)	KSHP8 × 6, KSHP8 × 6-11 (KSHP8 × 6-F11)
Maximum absorption capacity	J(in.lbs)	0.25 (2.213)	0.75 (6.638)
Absorption stroke	mm(in.)	4 (0.157)	6 (0.236)
Impact speed range	m/s(ft/s)	0.1 to 1 (0.33 to 3.28)	
Maximum operating cycle	cycle/min	50	
Maximum absorption capacity per unit of time	J/min (in.lbs/min)	7.5 (66.4)	22.5 (199.3)
Spring return force ^{Note1}	N	2.6	2.9
Deflection angle		1° or less	
Operating temperature range ^{Note2}	°C(°F)	0 to 60 (32 to 140)	

Item	Model (in inches)	KSHP10 × 8 (KSHP10 × 8-F11, KSHP11 × 8-F11)	KSHP12 × 10 (KSHP12 × 10-F11)	KSHP14 × 12 (KSHP14 × 12-F11)
Maximum absorption capacity	J(in.lbs)	2 (17.701)	4 (35.403)	5 (44.254)
Absorption stroke	mm(in.)	8 (0.315)	10 (0.394)	12 (0.472)
Impact speed range	m/s(ft/s)	0.1 to 2 (0.33 to 6.56)		
Maximum operating cycle	cycle/min	50		
Maximum absorption capacity per unit of time	J/min (in.lbs/min)	60 (531.4)	120 (1062.7)	150 (1328.4)
Spring return force ^{Note1}	N	6.5	9.6	9.0
Deflection angle		1° or less		
Operating temperature range ^{Note2}	°C(°F)	0 to 60 (32 to 140)		

Item	Model (in inches)	KSHP16 × 15	KSHP18 × 20 (KSHP18 × 20-F11)	KSHP20 × 22
Maximum absorption capacity	J(in.lbs)	10	15 (132.8)	20
Absorption stroke	mm(in.)	15	20 (0.787)	22
Impact speed range	m/s(ft/s)	0.1 to 2 (0.33 to 6.56)		
Maximum operating cycle	cycle/min	40		30
Maximum absorption capacity per unit of time	J/min (in.lbs/min)	240	360 (3188.2)	360
Spring return force ^{Note1}	N	20.5	23.0	18.4
Deflection angle		3° or less		
Operating temperature range ^{Note2}	°C(°F)	0 to 60 (32 to 140)		

Item	Model (in inches)	KSHP25 × 25 (KSHP25 × 25-F11)	KSHP30 × 30 (KSHP30 × 30-F11)	KSHP36 × 50 (KSHP36 × 50-F11)
Maximum absorption capacity	J(in.lbs)	40 (354.0)	110 (973.6)	200 (1770)
Absorption stroke	mm(in.)	25 (0.984)	30 (1.181)	50 (1.969)
Impact speed range	m/s(ft/s)	0.1 to 2 (0.33 to 6.56)	0.1 to 3 (0.33 to 9.84)	
Maximum operating cycle	cycle/min	30	20	15
Maximum absorption capacity per unit of time	J/min (in.lbs/min)	720 (6376.3)	1320 (11690)	1800 (15940.8)
Spring return force ^{Note1}	N	32.3	42.3	65.8
Deflection angle		3° or less		
Operating temperature range ^{Note2}	°C(°F)	0 to 60 (32 to 140)		

Item	Model (in inches)	KSHP42 × 50 (KSHP42 × 50-F11)
Maximum absorption capacity	J(in.lbs)	300 (2655)
Absorption stroke	mm(in.)	50 (1.969)
Impact speed range	m/s(ft/s)	0.1 to 3 (0.33 to 9.84)
Maximum operating cycle	cycle/min	10
Maximum absorption capacity per unit of time	J/min (in.lbs/min)	2000 (17712.0)
Spring return force ^{Note1}	N	64.2
Deflection angle		3° or less
Operating temperature range ^{Note2}	°C(°F)	0 to 60 (32 to 140)

Note1: The spring return force is the force of the piston rod when it returns from a full stroke. It is not stable, so cannot be used as other than rod return.

Note2: The shock absorber's shock absorbing capacity fluctuates based on speed and ambient temperature.

Use the product within the ranges of the selection graphs (impact mass, impact speed diagram) on page 50.

Note3: KSHP11 has only inch specifications.

* The maximum tightening torque of KSHP11 is different from that of KSHP10. See page 47 for details on the maximum tightening torque.

Note4: KSHP16 × 15 and KSHP20 × 22 do not have inch specifications.

Mass (Specifications in mm)

9

Model	Main unit ^{No.1}	Additional mass		Additional parts' mass		
		With plastic cap	With rubber cap	Mounting nut (1 ea.)	Stopper nut	Side mounting bracket
KSHP6 × 4	5.1	0.2	—	0.4	2	8
KSHP8 × 6 (-11)	11.3(11.5)	0.5	—	0.6(0.9)	4	12
KSHP10 × 8	26.5	0.7	—	1.2	7	15
KSHP12 × 10	43.5	1.1	1.2	1.9	8	22
KSHP14 × 12	66.5	1.1	1.8	4.0	15	41
KSHP16 × 15	99.5	1.6	3.4	6.6	28	65
KSHP18 × 20	144	4.1	5.3	8.8	37	100
KSHP20 × 22	186	5.4	6.9	12.2	55	110
KSHP25 × 25	360	5.3	5.7	23.0	95	360
KSHP3 × 30	569	50	49	32.5	140	455
KSHP36 × 50	1130	110	109	95.5	330	2650
KSHP42 × 50	1515	110	109	93.0	320	2400

Calculation example: The mass of KSHP10 × 8C-S-2 (with cap, stopper, and side mount) is
 $26.5 + 0.7 + 7 + 15 = 49.2g$

Note: The weight of the main unit includes the weight of 2 mounting nuts.

Order Codes (specifications in mm)

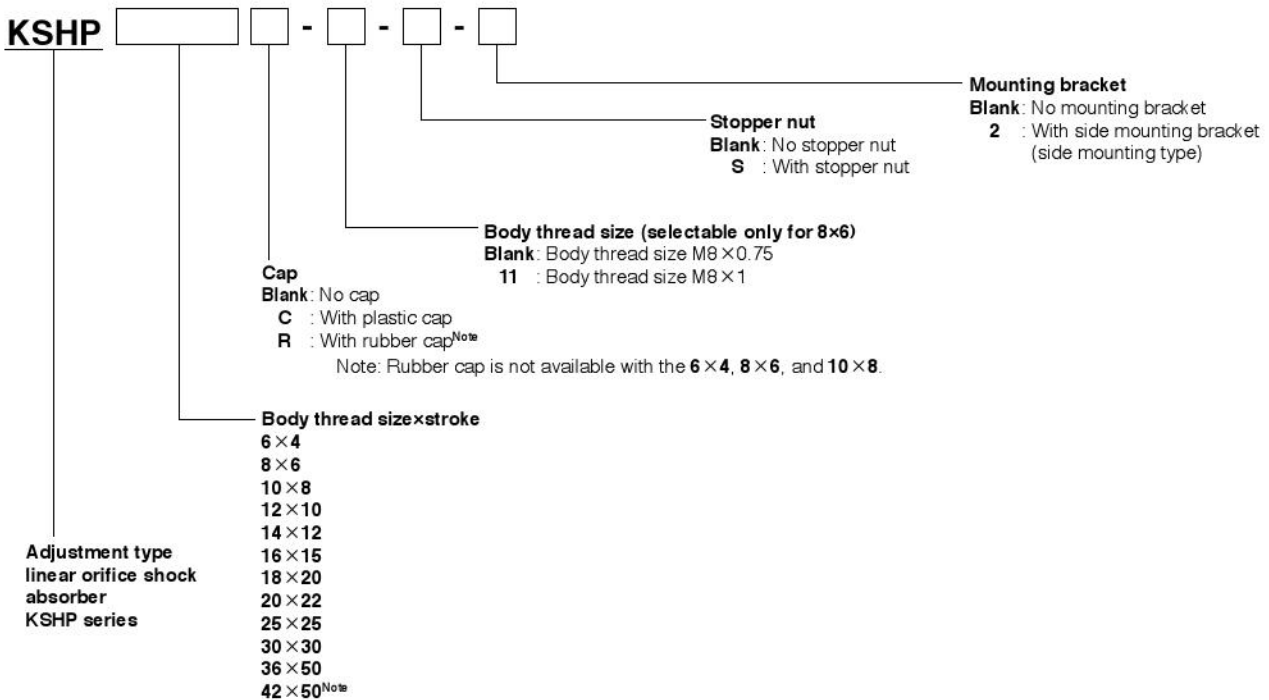

Note: KSHP42 × 50 is a built-to-order product. Contact us about turnaround times, prices, or other information.

Additional Parts (no specifications in inches)

•Rubber cap

R - KSH - M []



Thread size
 12: For KSHP12
 14: For KSHP14
 16: For KSHP16
 18: For KSHP18
 20: For KSHP20
 25: For KSHP25
 30: For KSHP30
 36: For KSHP36
 42: For KSHP42

•Mounting nut (M4 to M20: 1 pack has 10 units) (M25 to M42: 1 pack has 2 units)

N - KSH - M []



Thread size
 6: For KSHP6
 8: For KSHP8
 8-11: For KSHP8-11
 10: For KSHP10
 12: For KSHP12
 14: For KSHP14
 16: For KSHP16
 18: For KSHP18
 20: For KSHP20
 25: For KSHP25
 30: For KSHP30
 36: For KSHP36
 42: For KSHP42

•Stopper nut

S - KSH - M []



Thread size
 6: For KSHP6
 8: For KSHP8
 8-11: For KSHP8-11
 10: For KSHP10
 12: For KSHP12
 14: For KSHP14
 16: For KSHP16
 18: For KSHP18
 20: For KSHP20
 25: For KSHP25
 30: For KSHP30
 36: For KSHP36
 42: For KSHP42

•Side mounting bracket

2 - KSH - M []



Thread size
 6: For KSHP6
 8: For KSHP8
 8-11: For KSHP8-11
 10: For KSHP10
 12: For KSHP12
 14: For KSHP14
 16: For KSHP16
 18: For KSHP18
 20: For KSHP20
 25: For KSHP25
 30: For KSHP30
 36: For KSHP36
 42: For KSHP42

* For the dimension diagrams of the additional parts, see pages 72 to 76.
 * The stopper nut and side mount are made from mild steel (nickel plated).

Inner Construction and Major Parts and Materials

●M6, M8 size (11/4-32 UNEF, 5/16-32 UNEF) * The inch sizes are inside the ().

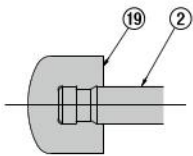
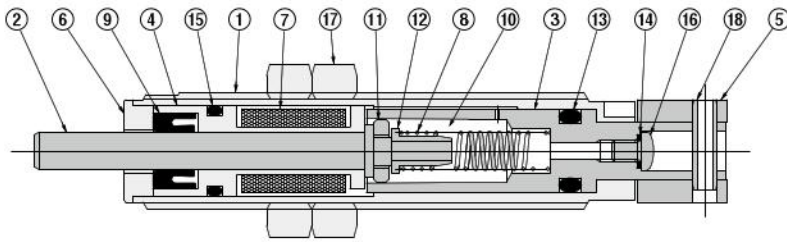

With plastic cap (C)

No	Name	Materials
①	Body	Stainless steel
②	Piston rod	Stainless steel
③	Inner tube	Stainless steel
④	Sleeve	Copper alloy
⑤	Adjusting knob	Copper alloy (black electroplated)
⑥	Plug	Stainless steel
⑦	Accumulator	Synthetic rubber
⑧	Spring	Spring steel
⑨	Rod seal	Synthetic rubber
⑩	Oil	Special oil (H1 compliant)
⑪	Piston ring	Copper alloy
⑫	Collar	Copper alloy
⑬	O-ring	Synthetic rubber
⑭	O-ring	Synthetic rubber
⑮	O-ring ^{Note}	Synthetic rubber
⑯	Screw	Mild steel (nickel plated)
⑰	Mounting nut	Mild steel (nickel plated)
⑱	Spring pin	Steel (oxide film)
⑲	Cap	Plastic (POM)

Note: Not available for KSHP6x4.

●M10 to M42 size (3/8-32 UNEF to 1 3/4-12 UN) * The inch sizes are inside the ().

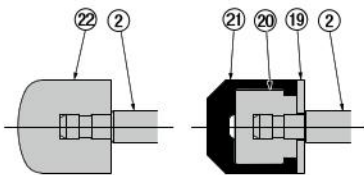
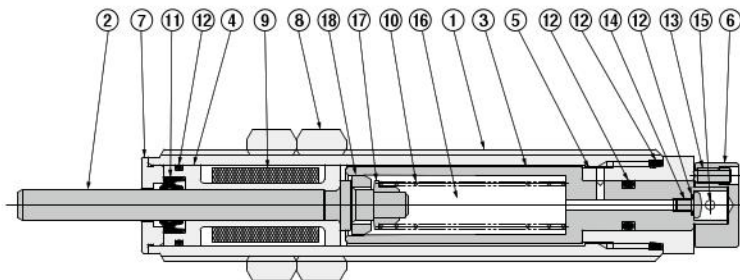

With plastic cap (C) With rubber cap (R)

For KSHP 30 × 30 and KSHP 42 × 50

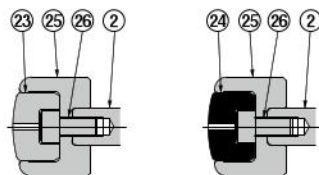

With plastic cap (C) With rubber cap (R)

No.	Name	Materials
①	Body	Free-cutting steel (nickel plated)
②	Piston rod ^{Note1}	Steel (nickel plated)
③	Inner tube	Stainless steel
④	Sleeve	Copper alloy
⑤	Housing	Mild steel (black electroplated)
⑥	Adjusting knob	Copper alloy (nickel plated)
⑦	Plug	Stainless steel
⑧	Mounting nut	Mild steel (nickel plated)
⑨	Accumulator	Synthetic rubber
⑩	Spring	Spring steel
⑪	Rod seal	Synthetic rubber
⑫	O-ring	Synthetic rubber
⑬	Lock screw ^{Note2}	Steel (oxide film)
⑭	Screw ^{Note3}	Mild steel (zinc plated)
⑮	Spring pin	Steel (oxide film)
⑯	Oil	Special oil (H1 compliant)
⑰	Collar ^{Note4}	Stainless steel
⑱	Piston ring	Stainless steel
⑲	Washers ^{Note5}	Stainless steel
⑳	Cap	Plastic (POM)
㉑	Rubber cap	Urethane rubber
㉒	Cap	Plastic (POM)
㉓	Cap	Plastic (POM)
㉔	Rubber cap	Urethane rubber
㉕	Metal cap	Stainless steel
㉖	Hexagon socket head screw	Stainless steel

Note 1: KSHP 10 to 12 are stainless steel
 2: KSHP 10 to 14 are slotted lock screws.
 3: KSHP 30 to 42 are stainless steel with button head screw
 4: KSHP 10 are copper alloy and KSHP 12 to 14 are sintered metal
 5: KSHP 18 to 20 only

Dimensions (mm)

● No rod end cap: **KSHP**□ × □

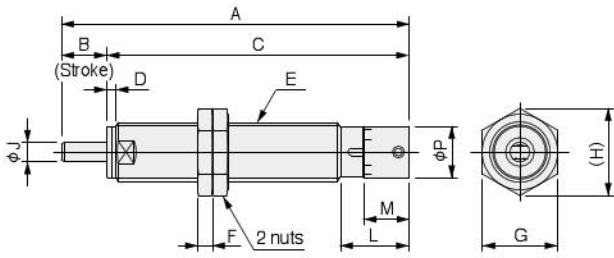

● With rod end cap

With plastic cap: **KSHP**□ × □C

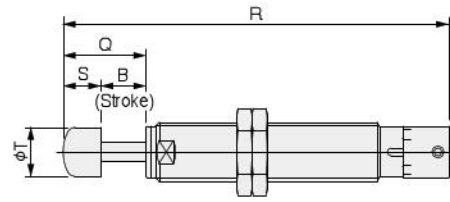

Model	Symbol	A	B	C	D	E	F	G	H	J	L	M	P	Q	R	S	T
KSHP6 × 4 (C)		36	4	32	0.5	M6×0.75	2	8	9.2	2	6.5	5.4	5	8	40	4	4.6
KSHP8 × 6 (C)		46	6	40	1.2	M8×0.75	2	10	11.5	2.5	9	6	6.8	11	51	5	6.5
KSHP8 × 6 (C)-11		46	6	40	1.2	M8×1	3	10	11.5	2.5	9	6	6.8	11	51	5	6.5

● No rod end cap: **KSHP**□ × □

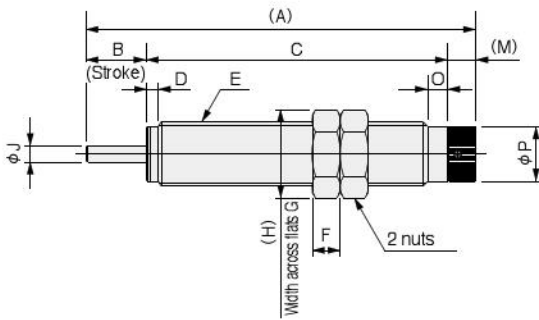

● With rod end cap

With plastic cap: **KSHP**□ × □C

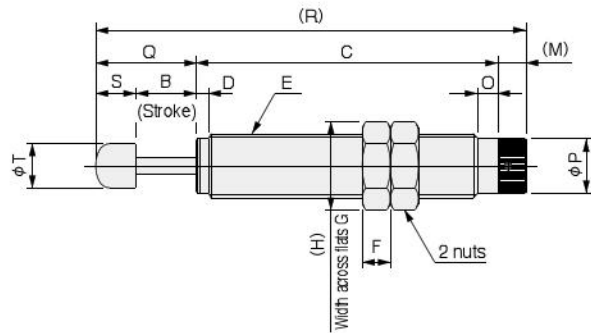

With rubber cap: **KSHP**□ × □R

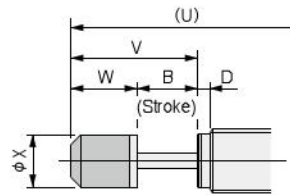

Note: Rubber cap is not available with the **KSHP10×8**

With rubber cap: For the **KSHP14 × 12R**

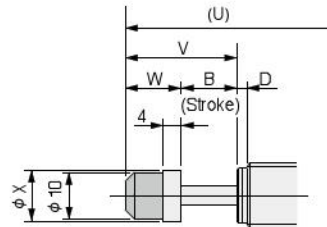

Model	Symbol	A	B	C	D	E	F	G	H	J	M	O	P	Q	R	S	T	U	V	W	X
KSHP10 × 8 (C)		69	8	56	6	M10×1	3	12	13.9	3	5	4	8.7	16	77	8	8	-	-	-	-
KSHP12 × 10 (C,R)		75	10	60	2	M12×1	4	14	16.2	3	5	4	10.7	20	85	10	10	85	20	10	10
KSHP14 × 12 (C,R)		87	12	70	2	M14×1.5	5	17	19.6	4	5	4	10.7	22	97	10	11	99	24	12	11
KSHP16 × 15 (C,R)		97	15	75	3	M16×1.5	7	19	21.9	4	7	5	13.5	25	107	10	11	113.5	31.5	16.5	13
KSHP18 × 20 (C,R)		116	20	89	3	M18×1.5	8	21	24.2	5	7	5	13.5	35	131	15	15	131.7	35.7	15.7	15
KSHP20 × 22 (C,R)		121	22	92	3	M20×1.5	8	24	27.7	5	7	5	17	40	139	18	16	139.2	40.2	18.2	16

Dimensions (mm)

● No rod end cap: **KSHP25 × 25**

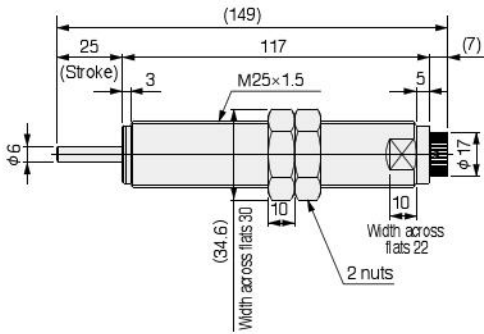

● With rod end cap

With plastic cap: **KSHP25 × 25C**

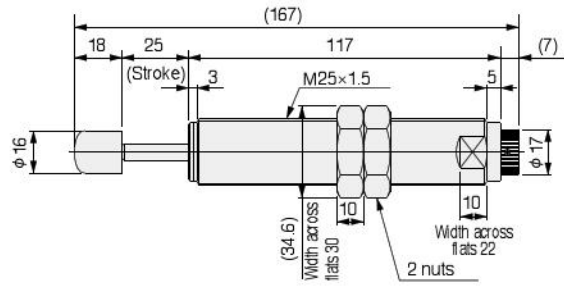

With rubber cap: **KSHP25 × 25R**

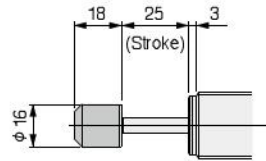

● No rod end cap: **KSHP□ × □**

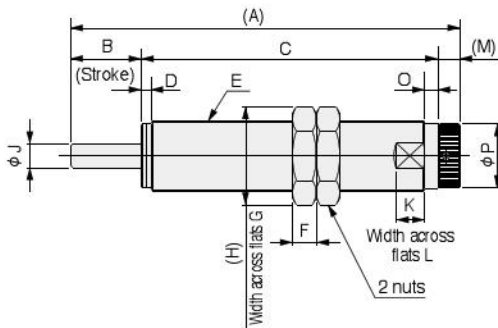

● With rod end cap

With plastic cap: **KSHP□ × □C**

With rubber cap: **KSHP□ × □R**

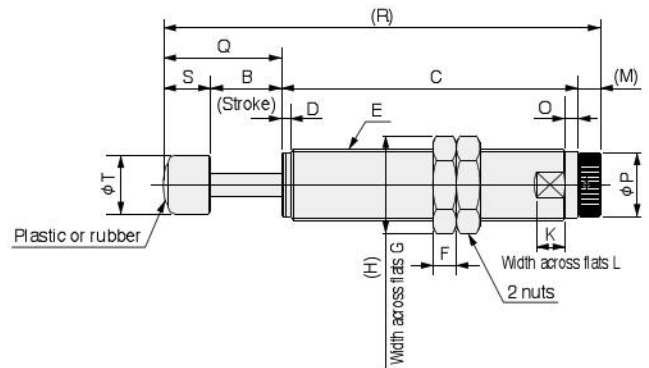

Model	Symbol	A	B	C	D	E	F	G	H	J	K	L	M	O	P	Q	R	S	T
KSHP30 × 30 (C,R)		165	30	125.5	4	M30 × 1.5	10	36	41.6	10	12	28	9.5	5.5	27	50	165	20	25
KSHP36 × 50 (C,R)		229	50	169.5	5	M36 × 1.5	15	46	53.1	12	12	33	9.5	6	27	55	254	25	32
KSHP42 × 50 (C,R)		235.5	50	173	5	M42 × 1.5	15	50	57.7	12	20	38	12.5	7	38	75	260.5	25	32

Mass (Specifications in inches)

Model	Main unit ^{Note1}	Additional mass		Additional parts' mass	
		With plastic cap	With rubber cap	Mounting nut (1 ea.)	Stopper nut
KSHP6 × 4 -F11	0.2	0.007	—	0.04	0.1
KSHP8 × 6 -F11	0.5	0.02	—	0.06	0.2
KSHP10 × 8 -F11	0.9	0.02	—	0.07	0.4
KSHP11 × 8 -F11	1.2	0.02	—	0.08	0.4
KSHP12 × 10 -F11	1.7	0.04	0.04	0.1	0.5
KSHP14 × 12 -F11	2.6	0.04	0.06	0.2	0.7
KSHP18 × 20 -F11	5.9	0.1	0.2	0.4	2.5
KSHP25 × 25 -F11	13.2	0.2	0.2	1.1	4.4
KSHP30 × 30 -F11	22.2	1.8	1.7	1.3	5.5
KSHP36 × 50 -F11	35.3	3.9	3.8	3.0	9.8
KSHP42 × 50 -F11	63.0	3.9	3.8	3.4	10.8

Calculation example: The mass of KSHP10×8C-S-2 (with cap and stopper) is

$$0.9 + 0.02 + 0.4 = 1.32\text{oz}$$

Note1: The weight of the main unit includes the weight of 2 mounting nuts.

Note2: KSHP11×8 has only inch specifications.

Order Codes (specifications in inches)

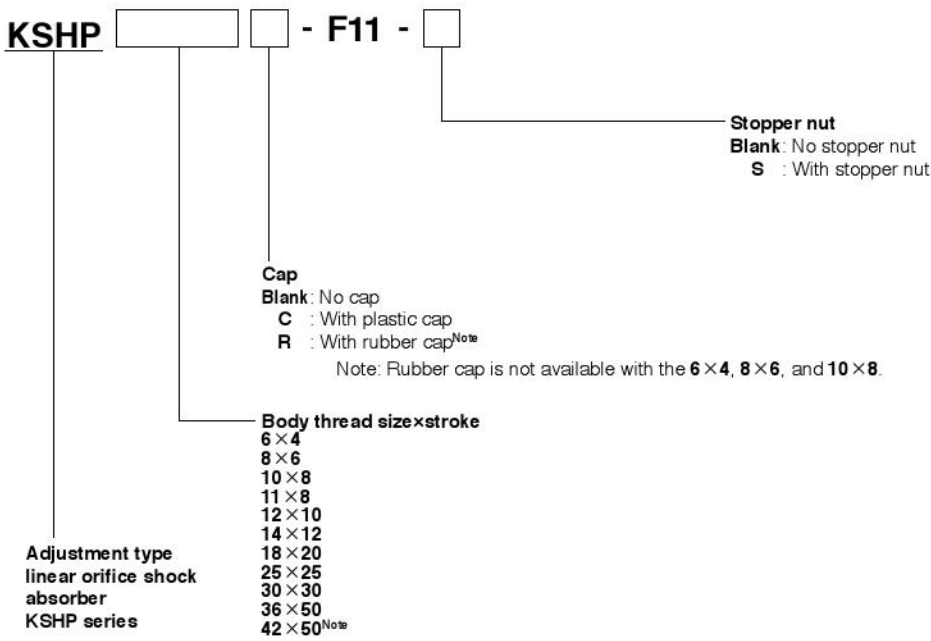

Note: KSHP42×50 is a built-to-order product. Contact us about turnaround times, prices, or other information.

Dimensions (in)

● No rod end cap: **KSHP**□ × □

● With rod end cap

With plastic cap: **KSHP**□ × □**C**

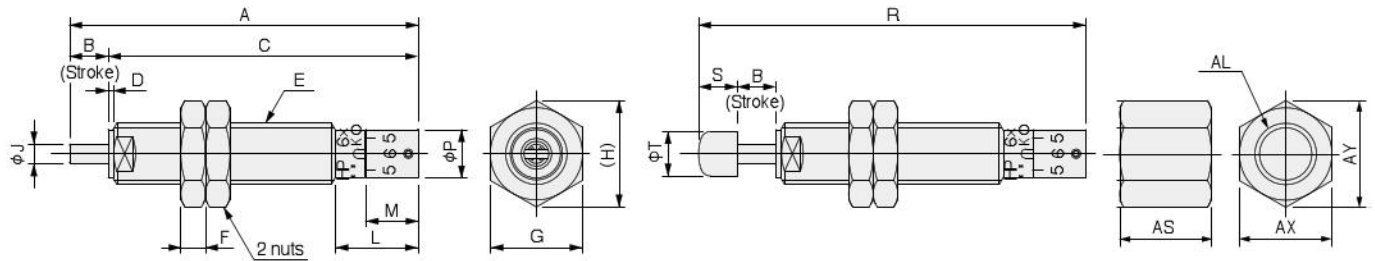

Model	Symbol	A	B	C	D	E	F	G	H	J	L	M	P	R	S
KSHP6 × 4 (C)-F11		1.417	0.157	1.26	0.02	1/4-32 UNEF	0.1	3/8	0.433	0.079	0.335	0.213	0.197	1.575	0.157
KSHP8 × 6 (C)-F11		1.811	0.236	1.575	0.047	5/16-32 UNEF	0.13	7/16	0.505	0.098	0.358	0.236	0.268	2.008	0.197

Model	Symbol	T	AL	AS	AX	AY
KSHP6 × 4 (C)-F11		0.181	1/4-32 UNEF	0.4	3/8	0.433
KSHP8 × 6 (C)-F11		0.256	5/16-32 UNEF	7/16	7/16	0.505

● No rod end cap: **KSHP**□ × □

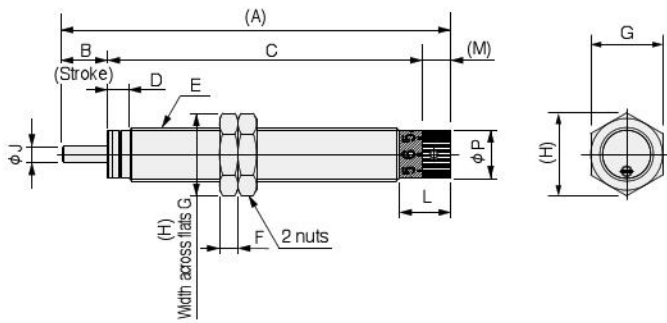

● With rod end cap

With plastic cap: **KSHP**□ × □**C**

With rubber cap: **KSHP**□ × □**R**

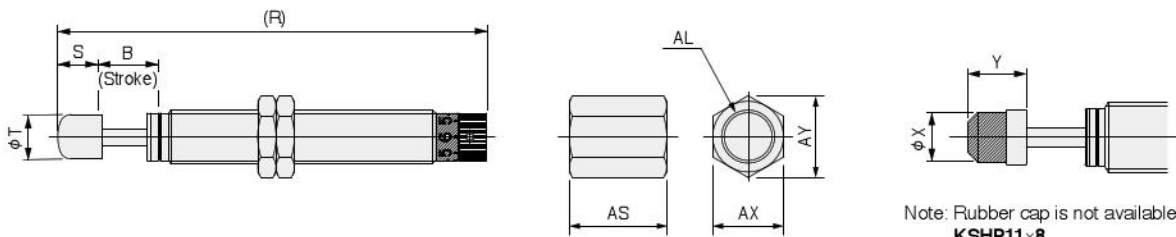

Note: Rubber cap is not available with the **KSHP10×8**, **KSHP11×8**

Model	Symbol	A	B	C	D	E	F	G	H	J	L	M	P	R	S
KSHP10 × 8 (C)-F11		2.724	0.315	2.409	0.157	3/8-32 UNEF	0.13	1/2	0.577	0.118	0.362	0.197	0.335	3.039	0.315
KSHP11 × 8 (C)-F11		2.724	0.315	2.409	0.157	7/16-28 UNEF	0.15	9/16	0.65	0.118	0.362	0.197	0.343	3.039	0.315
KSHP12 × 10 (C,R)-F11		2.961	0.394	2.567	0.157	1/2-20 UNF	0.15	5/8	0.722	0.118	0.362	0.197	0.421	3.354	0.394
KSHP14 × 12 (C,R)-F11		3.433	0.472	2.961	0.157	9/16-18 UNF	7/32	11/16	0.794	0.157	0.362	0.197	0.421	3.827	0.394
KSHP18 × 20 (C,R)-F11		4.575	0.787	3.787	0.197	3/4-16 UNF	1/4	15/16	1.082	0.197	0.48	0.276	0.531	5.165	0.591
KSHP25 × 25 (C,R)-F11		5.874	0.984	4.89	0.197	1-12 UNF	3/8	1 1/4	1.443	0.236	0.48	0.276	0.669	6.583	0.709

Model	Symbol	T	X	Y	AL	AS	AX	AY
KSHP10 × 8 (C)-F11		0.315	-	-	3/8-32 UNEF	11/16	1/2	0.577
KSHP11 × 8 (C)-F11		0.315	-	-	7/16-28 UNEF	11/16	9/16	0.65
KSHP12 × 10 (C,R)-F11		0.394	0.394	0.394	1/2-20 UNF	11/16	5/8	0.722
KSHP14 × 12 (C,R)-F11		0.433	0.433	0.472	9/16-18 UNF	3/4	11/16	0.794
KSHP18 × 20 (C,R)-F11		0.591	0.591	0.618	3/4-16 UNF	1 1/2	15/16	1.082
KSHP25 × 25 (C,R)-F11		0.63	0.63	0.709	1-12 UNF	1 1/2	1 1/4	1.443

Dimensions (in)

● No rod end cap: **KSHP**□ × □

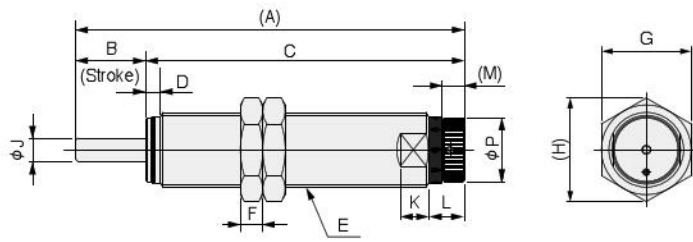

● With rod end cap

With plastic cap: **KSHP**□ × □**C**

With rubber cap: **KSHP**□ × □**R**

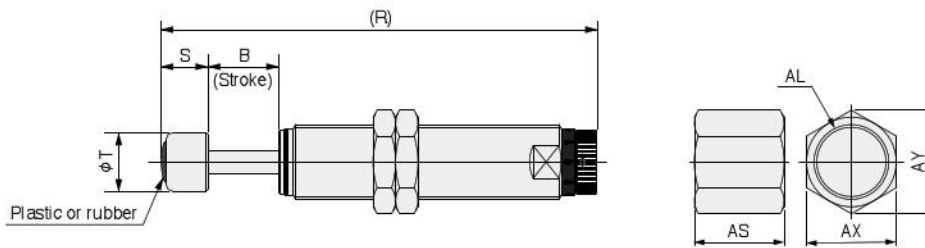

Model	Symbol	A	B	C	D	E	F	G	H	J	K	L	M	P	R	S
KSHP30 × 30 (C,R)-F11		6.496	1.181	5.315	0.236	1 1/4-12 UNF	3/8	1 1/2	1.732	0.394	0.472	0.591	0.354	1.063	7.283	0.787
KSHP36 × 50 (C,R)-F11		9.016	1.969	7.047	0.276	1 3/8-12 UNF	5/8	1 11/16	1.948	0.472	0.472	0.61	0.354	1.063	10	0.984
KSHP42 × 50 (C,R)-F11		9.272	1.969	7.303	0.276	1 3/4-12 UN	5/8	2	2.309	0.472	0.787	0.768	0.472	1.496	10.256	0.984

Model	Symbol	T	AL	AS	AX	AY
KSHP30 × 30 (C,R)-F11		0.984	1 1/4-12 UNF	1 1/2	1 1/2	1.732
KSHP36 × 50 (C,R)-F11		1.26	1 3/8-12 UNF	2	1 11/16	1.948
KSHP42 × 50 (C,R)-F11		1.26	1 3/4-12 UN	2	2	2.309

KSHJ

KSHY

KSHP

KSHC

Additional Parts

Linear Orifice Type KSHC Series Clean Room Specification Shock Absorbers



JIS/ISO Class 5 compliant
(FED-STD Class 100 equivalent)

**Smallest
M4 size**



CS-KSHC3×3

KSHJ

KSHY

KSHP

KSHC

Additional Parts

Handling instructions and precautions



General precautions

Cover the unit when mounting it in locations where it might be subject to excessive dust, dripping water, dripping oil, etc. Dents, scratches, water, oil, or dust on the piston rod results in damage and decreases service life.



Mounting

1. Keep the angle of eccentricity, resulting from the load direction and the axis of the shock absorber, under the specified values on pages 65 to 66. If an eccentric load exceeding the specifications is applied, it could result in breakage or impaired returns. If there is concern that an eccentric load exceeding the specified values will be applied, install a guide, or similar mechanism.
2. Two or more shock absorbers can be mounted in parallel, to boost absorption capacity. In such an arrangement, however, be careful to ensure that the load is evenly distributed to each shock absorber.
3. To adjust the capacity with the stroke, adjust the stopper nut (-S) or add an external stopper.
4. If using with a cap, always mount a stopper nut (-S) or an external stopper to ensure that the cap is not subjected to loads at the stroke end. The stopper nut mounting position must not exceed the distance shown in the table below. You can use it without a stopper nut or external stopper, but over the long-term, the stop location changes due to cap deformation and wear.

Model	A	
	mm	in
CS-KSHC3 × 3C(-F11)	3	0.118
CS-KSHC4 × 4C(-F11)	4	0.157
CS-KSHC5 × 5C(-11)(-F11)	5	0.197
CS-KSHC6 × 8C(-F11)	8	0.315
CS-KSHC7 × 8C-F11	—	0.315
CS-KSHC8 × 8C(-F11)	8	0.315
CS-KSHC9 × 10C(-F11)	10	0.394
CS-KSHC11 × 15C(-F11)	15	0.591
CS-KSHC14 × 16C	16	0.630
CS-KSHC18 × 25C(-F11)	25	0.984

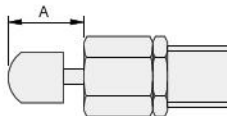

5. The small screw on the back end of the shock absorber should never be loosened or removed. Oil may leak out of the shock absorber leading to a loss of functionality and resulting in damage to the equipment and accidents.

6. When mounting the shock absorber, always use the following maximum tightening torque guidelines. Tightening using excessive force may result in damage.

Model	Maximum tightening torque	
	N · m	in · lbf
CS-KSHC3 × 3(C)(-F11)	0.5	4.426
CS-KSHC4 × 4(C)(-F11)	0.85	7.523
CS-KSHC5 × 5(C)(-11)(-F11)	2.5	22.128
CS-KSHC6 × 8(C)(-F11)	6.5	57.532
CS-KSHC7 × 8C-F11	—	57.5
CS-KSHC8 × 8(C)(-F11)	12.0	106.2
CS-KSHC9 × 10(C)(-F11)	12.0	106.2
CS-KSHC11 × 15(C)(-F11)	20.0	177.0
CS-KSHC14 × 16(C)	30.0	265.5
CS-KSHC18 × 25(C)(-F11)	42.0	371.7

7. Ensure that the hardness of the surface directly impacting the piston rod of the shock absorber is over HRc40 hardness (excluding models with cap).
8. Be aware that performance and characteristics change depending on the operating temperature.

Selection guidelines

How to select shock absorbers

1. Confirm the thrust

Confirm the thrust that is used, and then check the prospective shock absorbers from the table of recommended cylinder bore sizes on page 63. If a shock absorber that is smaller than the recommended shock absorber is used, the shock absorber being used may be damaged in fewer operation cycles than is guaranteed.

2. Confirm the kinetic energy

Confirm I and II below, and then check page 64 for the selection graph for prospective shock absorbers from [1. Confirm the thrust]. (*)

I Impact object mass: m [kg]

II Impact speed: v [m/s]

Because "v" is the impact speed, not the average speed, when using a cylinder,

$$v = m [\text{cylinder stroke}] \div s [\text{operating time}] \times 2$$

Select a model in which I and II fit within the range enclosed by the capacity curves.

If multiple models are applicable, use the model that is closest to both the capacity curves and the operating conditions. The further the model you select is from the capacity curves and the operating conditions, the slower it will tend to be.

3. Confirm other specifications

Confirm that such specifications as the maximum operating frequency, maximum absorption capacity per unit of time, angle of eccentricity, and operating temperature range are within the range for the shock absorber that you selected.

* The value for the kinetic energy, E , can be found by doing the following calculation. However, the shock absorber's capacity for absorption changes depending on the impact speed. When the shock absorber is doing low-speed operations, it has less drag than when it is doing high-speed operations.

The maximum absorption capacity that is noted in the specifications is reached only at the maximum impact speed.

Therefore, do not choose a shock absorber by comparing E to the maximum absorption capacity; confirm the capacity using the selection graph.

$$E = \frac{1}{2}mv^2$$

E : Kinetic energy (J)

m : Impact object mass [kg]

v : Impact speed (m/s)

Range in the selection graph

Vertical axis range :

$$\text{Maximum impact speed} \geq v \text{ Impact speed (operating condition)}$$

Horizontal axis range :

$$\text{Shock absorber's maximum absorption capacity at the impact speed (} v = m/s \text{)} \geq \begin{matrix} E \\ \text{Kinetic energy} \\ \text{(operating condition)} \end{matrix}$$

Calculating the thrust energy is not necessary because the size of the shock absorber is limited by the thrust in step 1.

Example of selecting a shock absorber

[Operating conditions]

① Bore size of the cylinder being used: $\phi 16$

② Cylinder stroke: 100 mm = 0.1 m

③ Pressure applied to the cylinder: 0.6 MPa

④ Cylinder's operating time: 0.4 s

⑤ Impact object mass: 10 kg

1. Confirm the thrust

Either calculate or find the thrust in the cylinder thrust table on page 63.

The cylinder thrust based on ① and ③ is about 121 N.

Cylinder thrust	100.5N	<	120.6N	<	126N
Cylinder bore size	$\phi 16$		$\phi 16$		$\phi 20$
Applied pressure	0.5MPa		0.6MPa		0.4MPa

As mentioned above, although the cylinder being used is $\phi 16$, the pressure applied to the cylinder exceeds 0.5 MPa, so consider the $\phi 20$ cylinder (lower than 0.4 MPa) and check the table of recommended cylinder bore sizes on page 63.

The following are prospective models.

- CS-KSHC6×8
- CS-KSHC8×8
- CS-KSHC9×10
- CS-KSHC11×15

2. Confirm the kinetic energy

I The impact object mass $m = 10$ kg from ⑤

II Find the impact speed, v , from ② and ④.

$$v = ② 0.1 \text{ m} \div ④ 0.4 \text{ s} \times 2 = 0.5 \text{ m/s}$$

According to the selection graph on page 64, the shock absorber with the optimum absorption capacity for operating conditions is CS-KSHC8×8-EF.

● CS-KSHC6×8

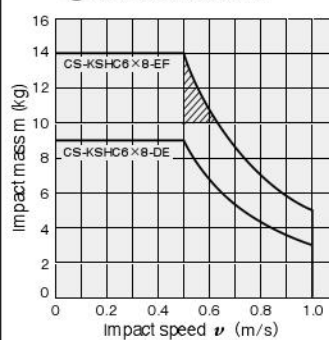

● CS-KSHC8×8

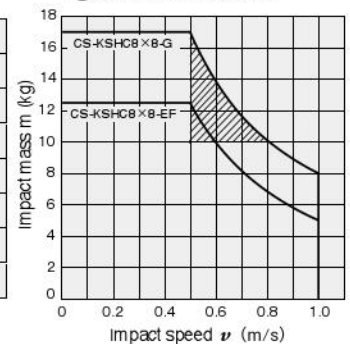

● CS-KSHC9×10

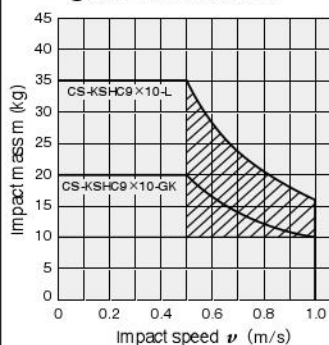

- CS-KSHC6×8-DE has an insufficient absorption capacity.
- The absorption capacities for all of the other shock absorbers are higher than that of CS-KSHC8×8-EF, so they do not fall within the operating conditions and capacity curves.

3. Confirm other specifications

Verify that other operating conditions, such as the maximum operating frequency, maximum absorption capacity per unit of time, angle of eccentricity, and operating temperature range, are within the specified ranges for CS-KSHC8×8-EF.

Selection guidelines

Recommended cylinder bore size

Model	Cylinder bore													
	φ 4	φ 6	φ 8	φ 10	φ 12	φ 16	φ 20	φ 25	φ 32	φ 40	φ 50	φ 63	φ 80	φ 100
CS-KSHC3×3(-F11)	◇	◎	◎	○										
CS-KSHC4×4(-F11)		◇	◎	○										
CS-KSHC5×5(-F11)			◇	◎	◎	○								
CS-KSHC6×8(-F11)				◇	◎	◎	○							
CS-KSHC7×8-F11					◎	◎	○							
CS-KSHC8×8(-F11)						◇	◎	○						
CS-KSHC9×10(-F11)						◇	◎	◎	○					
CS-KSHC11×15(-F11)							◇	◎	◎	○				
CS-KSHC14×16									◇	◎	◎	○		
CS-KSHC18×25(-F11)										◇	◎	◎	○	○

◇ : 0.3 MPa or higher ◎ : 0.5 MPa or lower ○ : 0.4 MPa or lower

Note1: If a shock absorber that is smaller than the recommended shock absorber is used, the shock absorber being used may be damaged in fewer operation cycles than the value that is guaranteed.

Note2: CS-KSHC7×8 has only inch specifications.

Cylinder thrust

N [lbf.]

Bore size mm [in.]	Pressure area mm ² [in. ²]	Air pressure MPa [psi.]								
		0.1 [15]	0.2 [29]	0.3 [44]	0.4 [58]	0.5 [73]	0.6 [87]	0.7 [102]	0.8 [116]	0.9 [131]
φ4	12.6 [0.020]	1.3 [0.292]	2.5 [0.562]	3.8 [0.854]	5 [1.124]	6.3 [1.416]	7.5 [1.666]	8.8 [1.978]	10.1 [2.270]	11.3 [2.540]
φ6	28.3 [0.044]	2.8 [0.629]	5.7 [1.281]	8.5 [1.911]	11.3 [2.540]	14.1 [3.170]	17.0 [3.822]	19.8 [4.451]	22.6 [5.080]	25.4 [5.710]
φ8	50.3 [0.078]	5 [1.124]	10.1 [2.270]	15.1 [3.394]	20.1 [4.518]	25.1 [5.642]	30.2 [6.789]	35.2 [7.913]	40.2 [9.037]	45.2 [10.161]
φ10	78.5 [0.122]	7.9 [1.776]	15.7 [3.529]	23.6 [5.305]	31.4 [7.059]	39.3 [8.835]	47.1 [10.588]	55 [12.364]	62.8 [14.117]	70.7 [15.893]
φ12	113 [0.175]	11.3 [2.540]	22.6 [5.080]	33.9 [7.621]	45.2 [10.161]	56.5 [12.701]	67.9 [15.264]	79.2 [17.804]	90.5 [20.344]	101.8 [22.885]
φ16	201 [0.312]	20.1 [4.518]	40.2 [9.037]	60.3 [13.555]	80.4 [18.074]	100.5 [22.592]	121 [27.201]	141 [31.697]	161 [36.193]	181 [40.689]
φ20	314 [0.487]	31.4 [7.059]	62.8 [14.117]	94.2 [21.176]	126 [28.325]	157 [35.294]	188 [42.262]	220 [49.456]	251 [56.425]	283 [63.618]
φ25	491 [0.761]	49.1 [11.038]	98.2 [22.075]	147 [33.046]	196 [44.061]	245 [55.076]	295 [66.316]	344 [77.331]	393 [88.346]	442 [99.362]
φ32	804 [1.246]	80.4 [18.074]	161 [36.193]	241 [54.177]	322 [72.386]	402 [90.370]	483 [108.6]	563 [126.6]	643 [144.5]	724 [162.8]
φ40	1257 [1.948]	126 [28.325]	251 [56.425]	377 [84.750]	503 [113.1]	628 [141.2]	754 [169.5]	880 [197.8]	1005 [225.9]	1131 [254.2]
φ50	1963 [3.043]	196 [44.061]	393 [88.346]	589 [132.4]	785 [176.5]	982 [220.8]	1178 [264.8]	1374 [308.9]	1571 [353.2]	1767 [397.2]
φ63	3117 [4.831]	312 [70.138]	623 [140.1]	935 [210.2]	1247 [280.3]	1559 [350.5]	1870 [420.4]	2182 [490.5]	2494 [560.7]	2806 [630.8]
φ80	5027 [7.792]	503 [113.1]	1005 [225.9]	1508 [339.0]	2011 [452.1]	2513 [564.9]	3016 [678.0]	3519 [791.1]	4021 [903.9]	4524 [1017]
φ100	7854 [1.217]	785 [176.5]	1571 [353.2]	2356 [529.6]	3142 [706.3]	3927 [882.8]	4712 [1059]	5498 [1236]	6283 [1412]	7069 [1589]

Selection guidelines

Cautions for using the selection graphs

1. The selection graphs are calculated with a cylinder operating air pressure of 0.5 MPa.
2. The values in the selection graphs are for room temperature (20 to 25°). Be aware that performance and characteristics change depending on the operating temperature.
3. Select a shock absorber that is as close to, yet within, the capacity line(s).

■ Selection graph

● CS-KSHC3 × 3 (-F11)

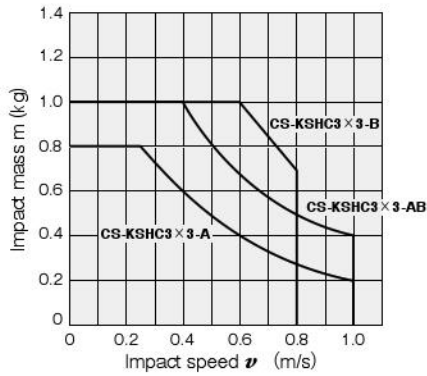

● CS-KSHC4 × 4 (-F11)

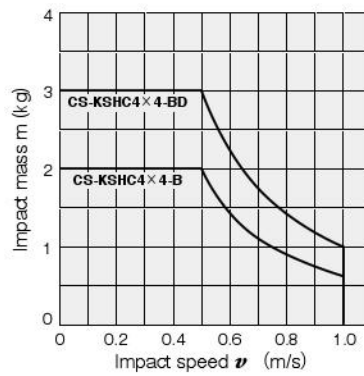

● CS-KSHC5 × 5 (-F11)

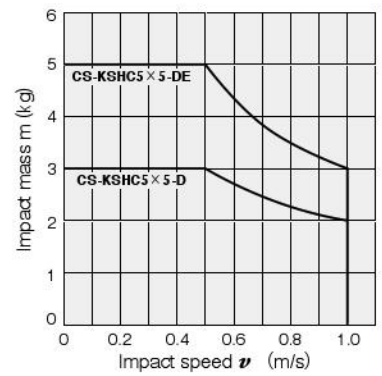

● CS-KSHC6 × 8 (-F11)

● CS-KSHC7 × 8-F11

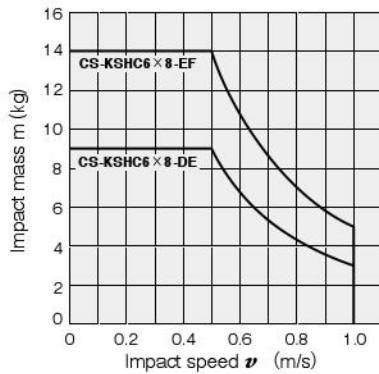

● CS-KSHC8 × 8 (-F11)

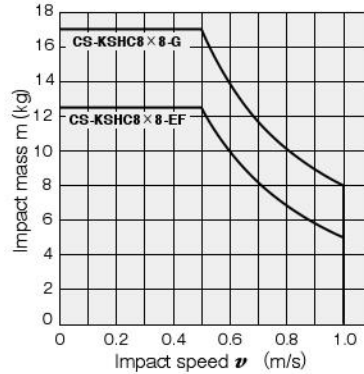

● CS-KSHC9 × 10 (-F11)

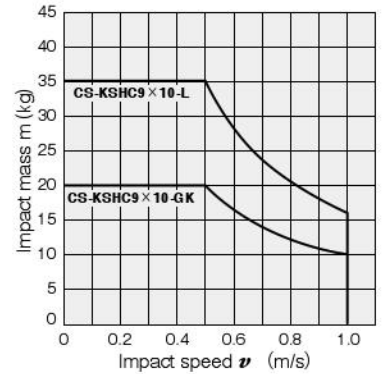

● CS-KSHC11 × 15 (-F11)

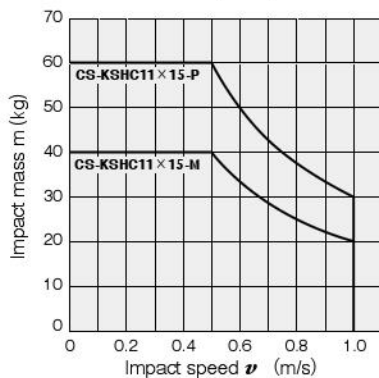

● CS-KSHC14 × 16

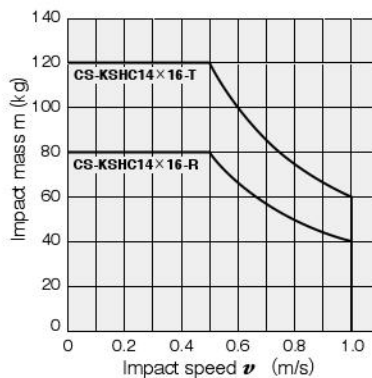

● CS-KSHC18 × 25 (-F11)

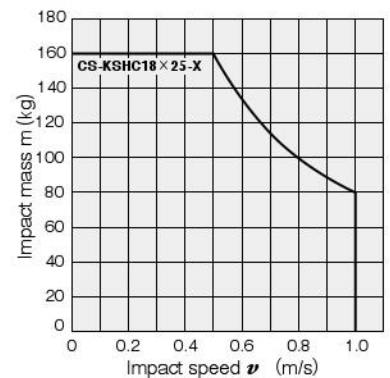

KSHJ

KSHY

KSPH

KSHC

Additional Parts

Clean room specifications
Shock absorber
 Linear orifice type

KSHC Series



Specifications

Item	Model (in inches)	CS-KSHC3 × 3-A (CS-KSHC3 × 3-A-F11)	CS-KSHC3 × 3-AB (CS-KSHC3 × 3-AB-F11)	CS-KSHC3 × 3-B (CS-KSHC3 × 3-B-F11)
Maximum absorption capacity	J(in. lbs)	0.1 (0.885)	0.2 (1.770)	0.3 (2.655)
Absorption stroke	mm(in.)	3 (0.118)		
Impact speed range	m/s(ft/s)	0.1 to 1.0 (0.33 to 3.28)		0.1 to 0.8 (0.33 to 2.62)
Maximum operating cycle	cycle/min	60		
Maximum absorption capacity per unit of time	J/min (in. lbs/min)	10 (88.6)		
Spring return force ^{Note 1}	N	2.0		
Deflection angle		1° or less		
Operating temperature range ^{Note 2}	°C(°F)	0 to 60 (32 to 140)		

Item	Model (in inches)	CS-KSHC4 × 4-B (CS-KSHC4 × 4-B-F11)	CS-KSHC4 × 4-BD (CS-KSHC4 × 4-BD-F11)	CS-KSHC5 × 5-D-11 (CS-KSHC5 × 5-F11-D)	CS-KSHC5 × 5-DE-11 (CS-KSHC5 × 5-F11-DE)
Maximum absorption capacity	J(in. lbs)	0.3 (2.655)	0.5 (4.425)	1.0 (8.851)	1.5 (13.276)
Absorption stroke	mm(in.)	4 (0.157)		5 (0.197)	
Impact speed range	m/s(ft/s)	0.1 to 1.0 (0.33 to 3.28)			
Maximum operating cycle	cycle/min	60			
Maximum absorption capacity per unit of time	J/min (in. lbs/min)	15 (132.8)		45 (398.5)	
Spring return force ^{Note 1}	N	3.0		6.0	
Deflection angle		1° or less			
Operating temperature range ^{Note 2}	°C(°F)	0 to 60 (32 to 140)			

Item	Model (in inches)	CS-KSHC6 × 8-DE (CS-KSHC6 × 8-DE-F11)	CS-KSHC6 × 8-EF (CS-KSHC6 × 8-EF-F11)	CS-KSHC8 × 8-EF (CS-KSHC8 × 8-EF-F11)	CS-KSHC8 × 8-G (CS-KSHC8 × 8-G-F11)
Maximum absorption capacity	J(in. lbs)	1.5 (13.276)	2.5 (22.127)	2.5 (22.127)	4.0 (35.403)
Absorption stroke	mm(in.)	8 (0.315)			8 (0.315)
Impact speed range	m/s(ft/s)	0.1 to 1.0 (0.33 to 3.28)			
Maximum operating cycle	cycle/min	60			
Maximum absorption capacity per unit of time	J/min (in. lbs/min)	75 (664.2)		120 (1062.7)	
Spring return force ^{Note 1}	N	8.5			
Deflection angle		1° or less			
Operating temperature range ^{Note 2}	°C(°F)	0 to 60 (32 to 140)			

Item	Model (in inches)	CS-KSHC9 × 10-GK (CS-KSHC9 × 10-GK-F11)	CS-KSHC9 × 10-L (CS-KSHC9 × 10-L-F11)	CS-KSHC11 × 15-M (CS-KSHC11 × 15-M-F11)	CS-KSHC11 × 15-P (CS-KSHC11 × 15-P-F11)
Maximum absorption capacity	J(in. lbs)	5.0 (44.254)	8.0 (70.806)	10 (88.507)	15 (132.8)
Absorption stroke	mm(in.)	10 (0.394)		15 (0.591)	
Impact speed range	m/s(ft/s)	0.1 to 1.0 (0.33 to 3.28)			
Maximum operating cycle	cycle/min	60		40	
Maximum absorption capacity per unit of time	J/min (in. lbs/min)	240 (2125.4)		300 (2656.8)	
Spring return force ^{Note 1}	N	8.5		18	
Deflection angle		1° or less			
Operating temperature range ^{Note 2}	°C(°F)	0 to 60 (32 to 140)			

Note1: The spring return force is the force of the piston rod when it returns from a full stroke. It is not stable, so cannot be used as other than rod return.

2: The shock absorbing capacity fluctuates based on speed and ambient temperature. Always use a product that is within the range shown by the solid lines in the graphs on pages 60.

* CS-KSHC7 has only inch specifications.

* The maximum tightening torque of CS-KSHC7 is different from that of CS-KSHC6. See page 61 for details on the maximum tightening torque.

Specifications

Item	Model (in inches)	CS-KSHC14×16-R	CS-KSHC14×16-T	CS-KSHC18×25-X (CS-KSHC18×25-F11-X)
Maximum absorption capacity	J(in.lbs)	20	30	40 (354.0)
Absorption stroke	mm(in.)	16		25 (0.984)
Impact speed range	m/s(ft/s)	0.1 to 1.0 (0.33 to 3.28)		
Maximum operating cycle	cycle/min	40		
Maximum absorption capacity per unit of time	J/min (in.lbs/min)	600		800 (7084.8)
Spring return force ^{Note 1}	N	18.6		32
Deflection angle		1° or less		
Operating temperature range ^{Note 2}	°C(°F)	0 to 60 (32 to 140)		

*CS-KSHC14 does not have inch specifications.

Order Codes (specifications in mm)

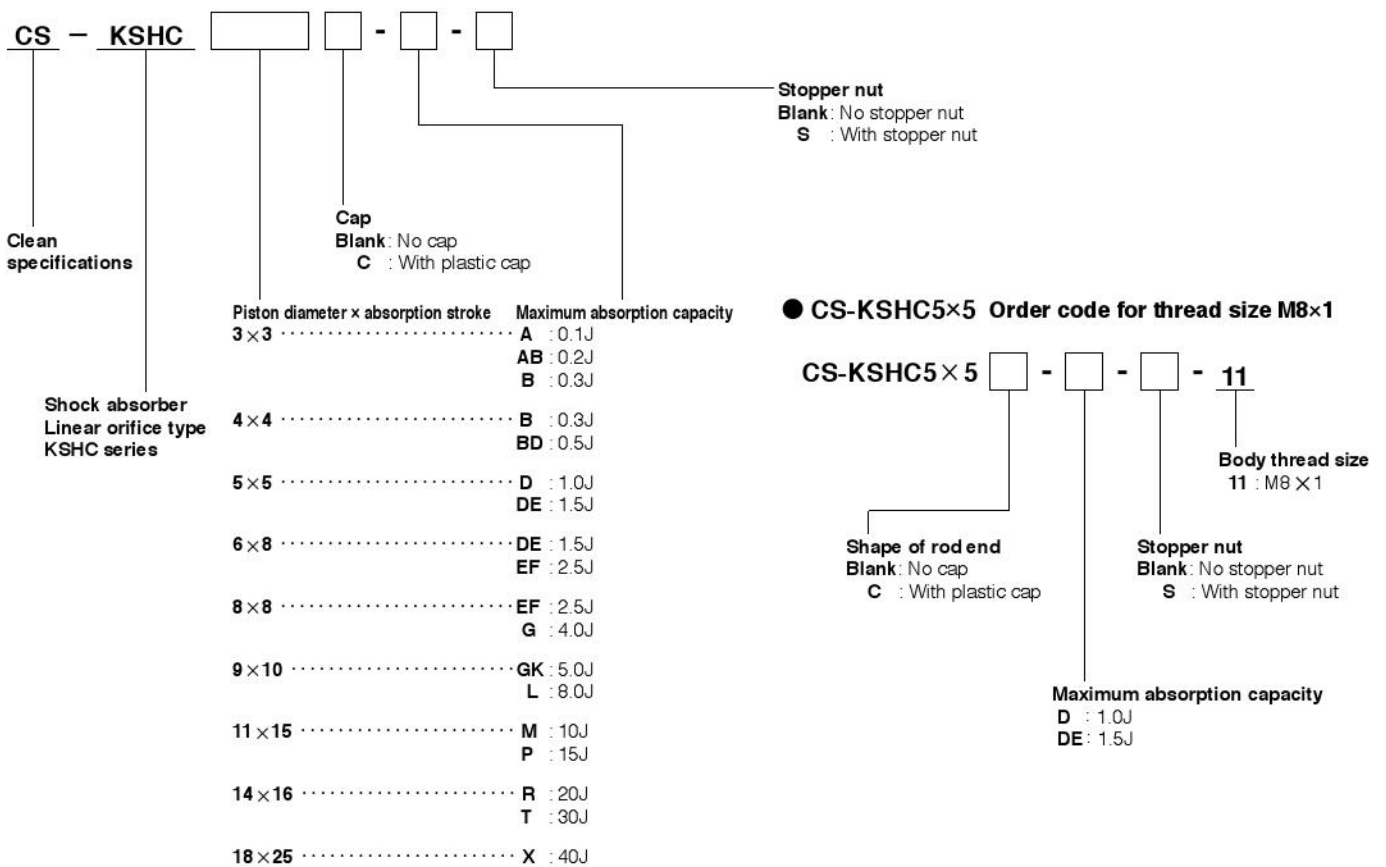

Additional Parts (no specifications in inches)

● Stopper nut

S - KSH - M []



- Thread size**
- 4 : For CS-KSHC3×3
 - 6 : For CS-KSHC4×4
 - 8 : For CS-KSHC5×5
 - 8-11 : For CS-KSHC5×5-11
 - 10 : For CS-KSHC6×8
 - 12 : For CS-KSHC8×8
 - 14 : For CS-KSHC9×10
 - 16 : For CS-KSHC11×15
 - 20 : For CS-KSHC14×16
 - 25 : For CS-KSHC18×25

● Mounting nut (M4 to M20 : 1 pack has 10 pieces) M25 : 1 pack has 2 pieces)

N - KSH - M []



- Thread size**
- 4 : For CS-KSHC3×3
 - 6 : For CS-KSHC4×4
 - 8 : For CS-KSHC5×5
 - 8-11 : For CS-KSHC5×5-11
 - 10 : For CS-KSHC6×8
 - 12 : For CS-KSHC8×8
 - 14 : For CS-KSHC9×10
 - 16 : For CS-KSHC11×15
 - 20 : For CS-KSHC14×16
 - 25 : For CS-KSHC18×25

* For the dimension diagrams of the additional parts, see page 72.
* The stopper nut is made from mild steel (nickel plated).

Mass (specifications in mm)

Model	Main unit ^{Note}	Additional mass		
		With plastic cap	Mounting nut (1 ea.)	Stopper nut
CS-KSHC3×3	1.8	0.1	0.2	0.8
CS-KSHC4×4	4.8	0.1	0.4	2
CS-KSHC5×5-01,-11	9.2	0.3	0.6(0.9)	4
CS-KSHC6×8	21	1	1.2	7
CS-KSHC8×8	32	1	1.9	8
CS-KSHC9×10	58	2	4	15
CS-KSHC11×15	94	2	6.6	29
CS-KSHC14×16	172	3	12.2	50
CS-KSHC18×25	350	7	23	100

Calculation example: The mass of CS-KSHC6×8 (with cap and stopper) is
21 + 1 + 7 = 29g

Note: The weight of the main unit includes the weight of 2 mounting nuts.

Inner Construction and Major Parts and Materials

- CS-KSHC3×3
- CS-KSHC4×4
- CS-KSHC5×5

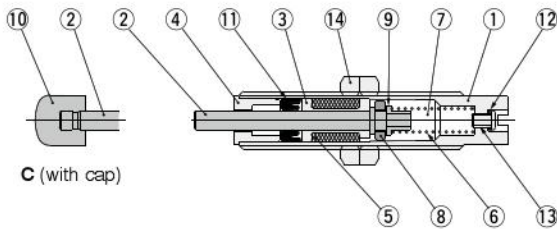

- CS-KSHC6×8
- CS-KSHC8×8
- CS-KSHC9×10

- CS-KSHC11×15
- CS-KSHC14×16
- CS-KSHC18×25

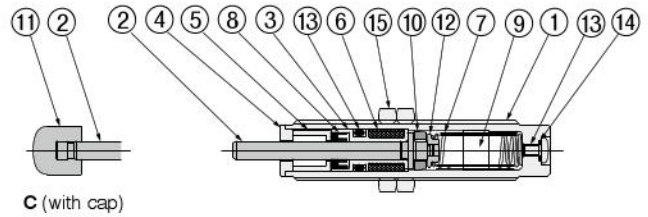

Note: Depending on size, some part shapes and configurations may differ.

- CS-KSHC3×3, 4×4, 5×5

No.	Name	Materials
①	Body ^{Note 1}	Copper alloy (nickel plated)
②	Piston rod ^{Note 2}	Steel (nickel plated)
③	Sleeve	Copper alloy
④	Plug	Stainless steel
⑤	Accumulator	Synthetic rubber
⑥	Spring	Spring steel
⑦	Oil	Special oil
⑧	Piston ring	Copper alloy
⑨	Collar ^{Note 3}	Copper alloy
⑩	Cap	Plastic (POM)
⑪	Rod seal	Synthetic rubber
⑫	O-ring	Synthetic rubber
⑬	Screw	Mild steel (nickel plated)
⑭	Mounting nut ^{Note 4}	Mild steel (nickel plated)

Note1: CS-KSHC3, 4 are stainless steel

2: CS-KSHC5 is stainless steel

3: CS-KSHC3 is stainless steel

4: CS-KSHC3 is stainless steel

- CS-KSHC6×8, 8×8, 9×10, 11×15, 14×16, 18×25

No.	Name	Materials
①	Body	Copper alloy (nickel plated)
②	Piston rod ^{Note 1}	Steel (nickel plated)
③	Sleeve	Copper alloy
④	Plug	Stainless steel
⑤	Spacer	Stainless steel
⑥	Accumulator	Synthetic rubber
⑦	Spring	Spring steel
⑧	Rod seal	Synthetic rubber
⑨	Oil	Special oil
⑩	Piston ring	Copper alloy
⑪	Cap	Plastic (POM)
⑫	Collar ^{Note 2}	Sintered metal
⑬	O-ring	Synthetic rubber
⑭	Screw	Mild steel (zinc plated)
⑮	Mounting nut	Mild steel (nickel plated)

Note1: CS-KSHC6, 8 are stainless steel

2: CS-KSHC11, 14, 18 are stainless steel

Dimensions (mm)

● No rod end cap: CS-KSHC3×3, CS-KSHC4×4

● With rod end cap: CS-KSHC3×3C, CS-KSHC4×4C

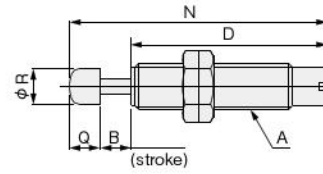
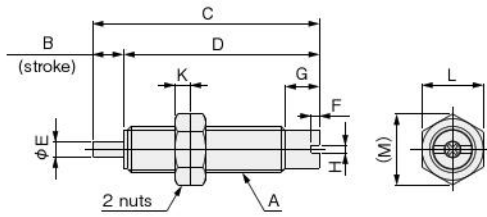

Model	Symbol	A	B	C	D	E	F	G	H	K	L	M	N	Q	R
CS-KSHC3×3□		M4×0.5	3	25	22	1.2	1.1	3	1	2	5.5	6.4	28.5	3.5	3.2
CS-KSHC4×4□		M6×0.75	4	33.5	29.5	2	1	5.5	1	2	8	9.2	37.5	4	4.6

● No rod end cap: CS-KSHC5×5-11

● With rod end cap: CS-KSHC5×5C-11

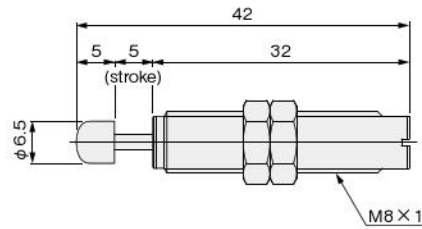
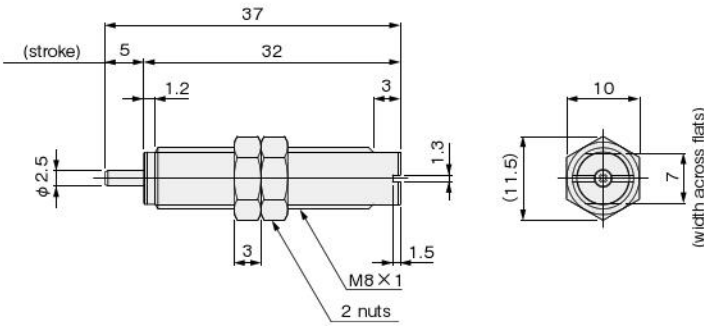

● No rod end cap: CS-KSHC□×□

● With rod end cap: CS-KSHC□×□C

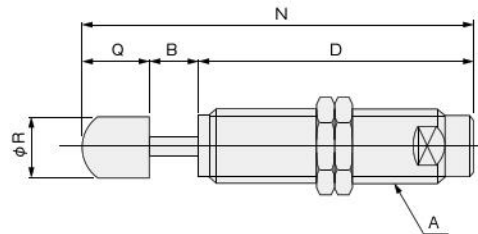
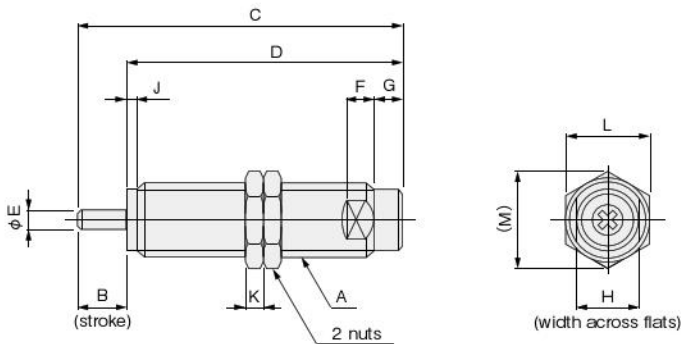

Model	Symbol	A	B	C	D	E	F	G	H	J	K	L	M	N	Q	R
CS-KSHC5×5□		M8×0.75	5	36	31	2.5	3	5	7	1.2	2	10	11.5	41	5	6.5
CS-KSHC6×8□		M10×1	8	53	45	3	4	5	9	2	3	12	13.9	61	8	8
CS-KSHC8×8□		M12×1	8	53	45	3	5	5.5	11	2	4	14	16.2	63	10	10
CS-KSHC9×10□		M14×1.5	10	70	60	4	5	5.5	12	2	5	17	19.6	80	10	11
CS-KSHC11×15□		M16×1.5	15	87	72	4	5	6	14	3	7	19	21.9	97	10	11
CS-KSHC14×16□		M20×1.5	16	98	82	5	6	6	18	3	8	24	27.7	113	15	15
CS-KSHC18×25□		M25×1.5	25	135	110	6	7	6	23	3	10	30	34.6	153	18	18

KSHJ

KSHY

KSHP

KSHC

Additional Parts

Order Codes (specifications in inches)

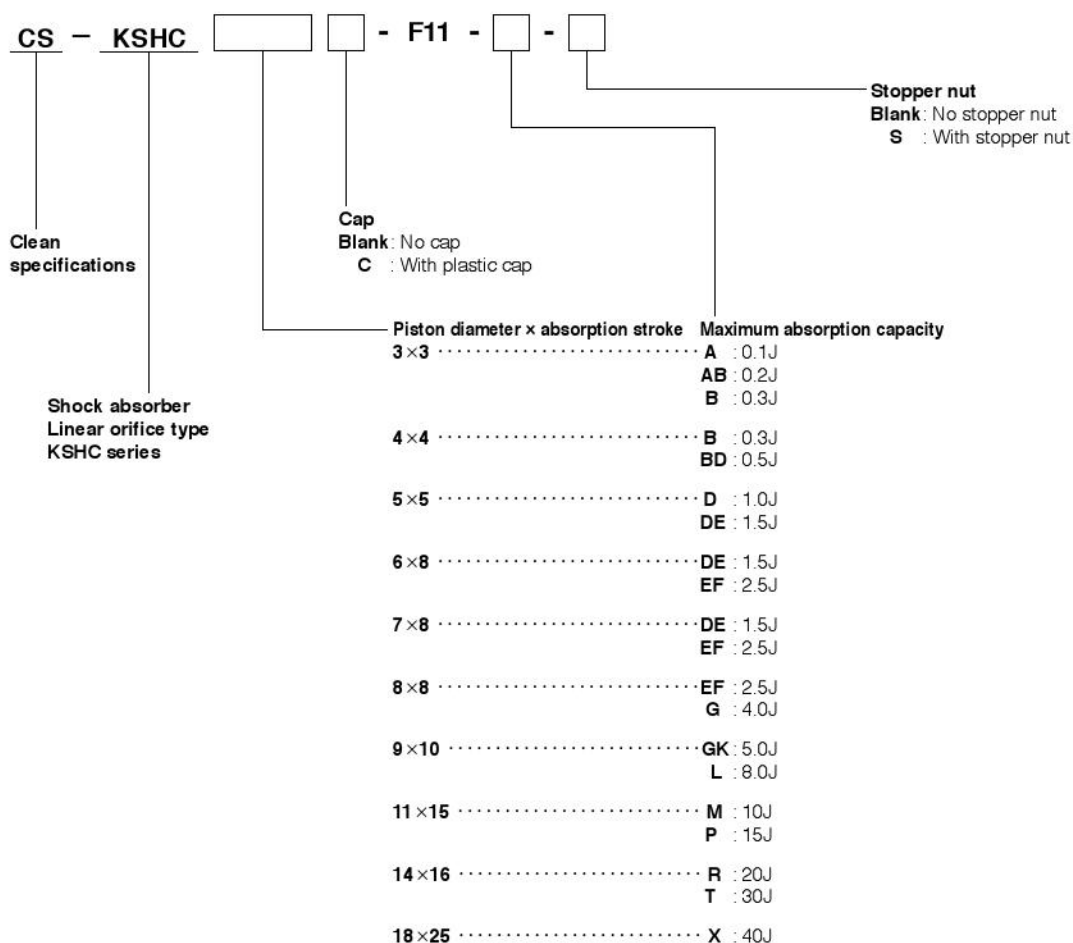

Mass (specifications in inches)

oz

Model	Main unit ^{Note1}	Additional mass	Additional parts' mass	
		With plastic cap	Mounting nut (1 ea.)	Stopper nut
CS-KSHC3x3-F11	0.1	0.004	0.01	0.04
CS-KSHC4x4-F11	0.2	0.004	0.04	0.1
CS-KSHC5x5-F11-D,DE	0.4	0.01	0.06	0.2
CS-KSHC6x8-F11	0.7	0.04	0.07	0.4
CS-KSHC7x8-F11	1.0	0.04	0.09	0.4
CS-KSHC8x8-F11	1.3	0.04	0.1	0.5
CS-KSHC9x10-F11	2.2	0.07	0.2	0.7
CS-KSHC11x15-F11	5.1	0.07	0.4	2.5
CS-KSHC18x25-F11	12.7	0.2	1.1	4.8

Calculation example: The mass of CS-KSHC6x8 (with cap and stopper) is
 $0.7 + 0.04 + 0.4 = 1.14\text{oz}$

Note1: The weight of the main unit includes the weight of 2 mounting nuts.

Note2: CS-KSHC7x8 has only inch specifications.

Dimensions (in)

● No rod end cap: CS-KSHC3×3, CS-KSHC4×4

● With rod end cap: CS-KSHC3×3C, CS-KSHC4×4C

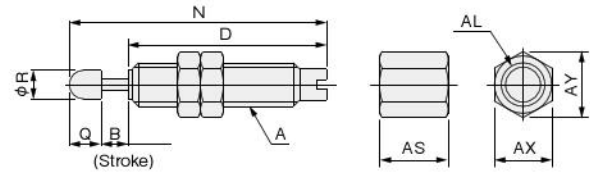
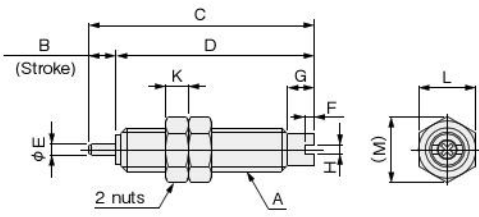

Model	Symbol	A	B	C	D	E	F	G	H	K	L	M	N	Q
CS-KSHC3×3 (C)-F11	#10-32 UNF	0.118	0.984	0.866	0.047	0.043	0.118	0.039	0.1	1/4	0.289	1.122	0.138	
CS-KSHC4×4 (C)-F11	1/4-32 UNEF	0.157	1.319	1.161	0.079	0.039	0.217	0.039	0.1	3/8	0.433	1.476	0.157	

Model	Symbol	R	AL	AS	AX	AY
CS-KSHC3×3 (C)-F11		0.126	#10-32 UNF	0.3	1/4	0.289
CS-KSHC4×4 (C)-F11		0.181	1/4-32 UNEF	0.4	3/8	0.433

● No rod end cap: CS-KSHC□×□

● With rod end cap: CS-KSHC□×□C

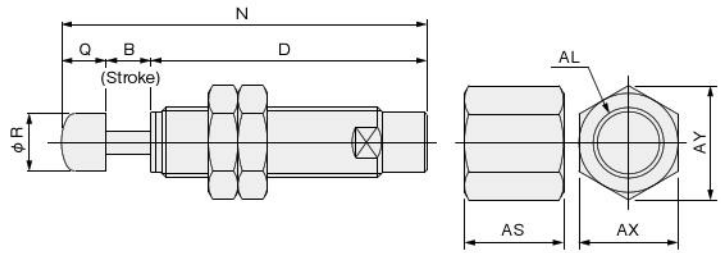
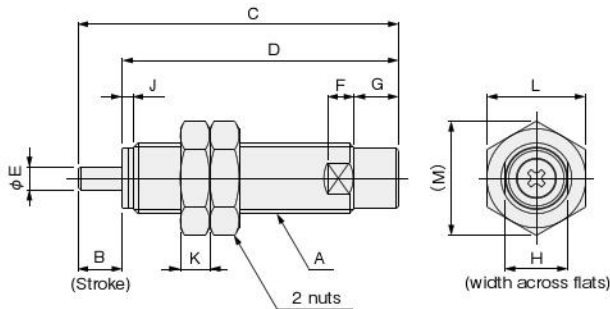

Model	Symbol	A	B	C	D	E	F	G	H	J	K	L	M	N	Q
CS-KSHC5×5 (C)-(-11)-F11	5/16-32 UNEF	0.197	1.417	1.22	0.098	0.118	0.197	0.276	0.047	0.13	7/16	0.505	1.614	0.197	
CS-KSHC6×8 (C)-F11	3/8-32 UNEF	0.315	2.087	1.772	0.118	0.157	0.197	0.354	0.079	0.13	1/2	0.577	2.401	0.315	
CS-KSHC7×8 (C)-F11	7/16-28 UNEF	0.315	2.087	1.772	0.118	0.157	0.197	3/8	0.079	0.15	9/16	0.65	2.401	0.315	
CS-KSHC8×8 (C)-F11	1/2-20 UNF	0.315	2.087	1.772	0.118	0.197	0.217	7/16	0.079	0.15	5/8	0.722	2.48	0.394	
CS-KSHC9×10 (C)-F11	9/16-18 UNF	0.394	2.756	2.362	0.157	0.197	0.217	1/2	0.079	7/32	11/16	0.794	3.15	0.394	
CS-KSHC11×15 (C)-F11	3/4-16 UNF	0.591	3.425	2.835	0.157	0.276	0.236	5/8	0.118	1/4	15/16	1.082	3.819	0.394	
CS-KSHC18×25 (C)-F11	1-12 UNF	0.984	5.315	4.331	0.236	0.276	0.236	0.875	0.118	3/8	1 1/4	1.443	6.024	0.709	

Model	Symbol	R	AL	AS	AX	AY
CS-KSHC5×5 (C)-(-11)-F11		0.256	5/16-32 UNEF	7/16	7/16	0.505
CS-KSHC6×8 (C)-F11		0.315	3/8-32 UNEF	11/16	1/2	0.577
CS-KSHC7×8 (C)-F11		0.315	7/16-28 UNEF	11/16	9/16	0.65
CS-KSHC8×8 (C)-F11		0.394	1/2-20 UNF	11/16	5/8	0.722
CS-KSHC9×10 (C)-F11		0.433	9/16-18 UNF	3/4	11/16	0.794
CS-KSHC11×15 (C)-F11		0.433	3/4-16 UNF	1 1/2	15/16	1.082
CS-KSHC18×25 (C)-F11		0.709	1-12 UNF	1 1/2	1 1/4	1.443

KSHJ

KSHY

KSHP

KSHC

Additional Parts

About the evaluation of cleanliness (shock absorber KSHC series)

Currently, methods for evaluating the degree of cleanliness of shock absorbers are not defined by JIS or other standards. Because of this, Koganei devises its own independent measurement methods for cleanliness and does evaluations accordingly.

● Measurement method

1. We measure particles in the clean bench (Figure 1) without activating the shock absorber for measurements and the load driving cylinder in the clean bench (background measurement).^{Note}

Note: Under the background measurement conditions, the number of particles measures zero.

2. We start driving a load to activate the shock absorber under the measurement conditions, and then measure the particles.

● Measurement conditions

Load impact speed	: 300mm/s
Shock absorber operating frequency	: 30cycle/min ^{Note}
Particle measurement time	: 1 minute
Suction rate	: 1cf/min
Measured particles	: 0.1 μm or greater

For reference, a graph of actual values is shown in Figure 2. The number of particles is the average value of the test samples. Also, the smaller the angle of eccentricity when mounting the shock absorber, the lower the number of particles is likely to be. We recommend mounting the shock absorber so that its angle of eccentricity to the workpiece is as small as possible.

Note1: The number of particles is based on 30 operation cycles. When using the shock absorbers, the customer's evaluation should be based on the customer's own operation frequency.

2: FED-STD Class 1 equivalent.

3: The numbers of particles in the graph are actual values measured under Koganei standards, and are not intended to be guaranteed values.

● Outline of particle measuring device

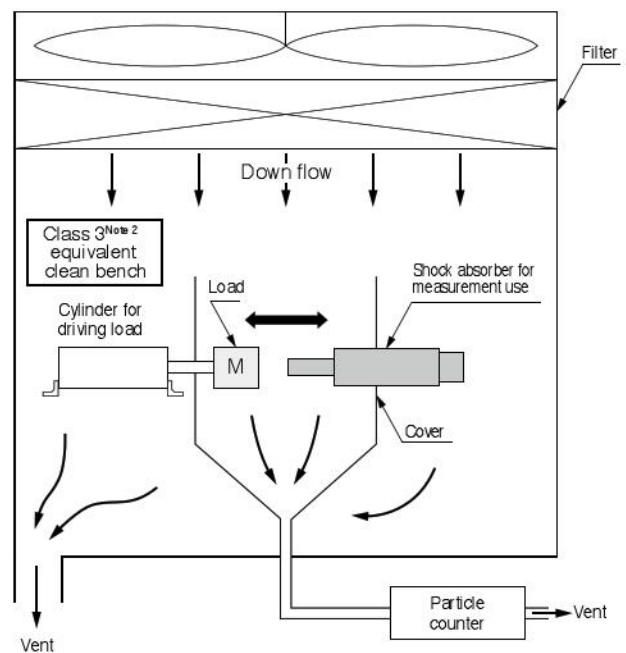

Figure 1

● Number of particles (measured value)^{Note 3}

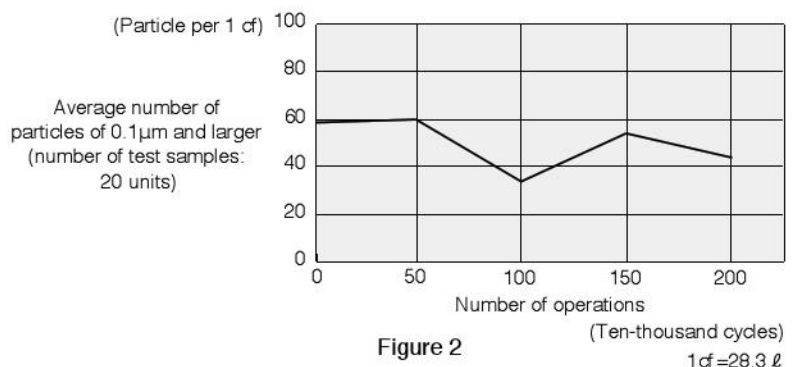
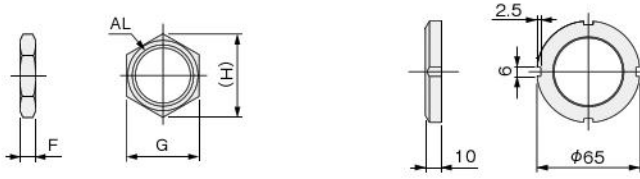

Figure 2

Dimensions of Additional Parts (mm)

● Mounting nut: N-KSH-□-□

N-KSH-M45 (for KSHJ45)



Symbol Model	AL	F	G	H	Applicable shock absorbers			
					KSHJ	KSHY	KSHP	CS-KSHC
N-KSH-M4	M4×0.5	2	5.5	6.4	KSHJ4	—	—	CS-KSHC3
N-KSH-M6	M6×0.75	2	8	9.2	KSHJ6	KSHY6	KSHP6	CS-KSHC4
N-KSH-M8	M8×0.75	2	10	11.5	KSHJ8(-01,02)	KSHY8(-01,02)	KSHP8	CS-KSHC5
N-KSH-M8-11	M8×1	3	10	11.5	KSHJ8(-11,12)	KSHY8(-11,12)	KSHP8-11	CS-KSHC5-11
N-KSH-M10	M10×1	3	12	13.9	KSHJ10	KSHY10	KSHP10	CS-KSHC6
N-KSH-M12	M12×1	4	14	16.2	KSHJ12	KSHY12	KSHP12	CS-KSHC8
N-KSH-M14	M14×1.5	5	17	19.6	KSHJ14	KSHY14	KSHP14	CS-KSHC9
N-KSH-M16	M16×1.5	7	19	21.9	KSHJ16	KSHY16	KSHP16	CS-KSHC11
N-KSH-M18	M18×1.5	8	21	24.2	KSHJ18	—	KSHP18	—
N-KSH-M20	M20×1.5	8	24	27.7	KSHJ20	KSHY20	KSHP20	CS-KSHC14
N-KSH-M22	M22×1.5	9	27	31.2	KSHJ22	—	—	—
N-KSH-M25	M25×1.5	10	30	34.6	KSHJ25-01	—	KSHP25	CS-KSHC18
N-KSH-M25-11	M25×2	10	30	34.6	KSHJ25(-11,12)	—	—	—
N-KSH-M27	M27×1.5	10	36	41.6	KSHJ27(-01,02)	—	—	—
N-KSH-M27-11	M27×3	12	36	41.6	KSHJ27(-11,12)	—	—	—
N-KSH-M30	M30×1.5	10	36	41.6	KSHJ30	—	KSHP30	—
N-KSH-M33	M33×1.5	10	41	47.3	KSHJ33	—	—	—
N-KSH-M36	M36×1.5	15	46	53.1	KSHJ36	—	KSHP36	—
N-KSH-M42	M42×1.5	15	50	57.7	KSHJ42	—	KSHP42	—
N-KSH-M48	M48×2	15	55	63.5	KSHJ48	—	—	—

● Stopper nut: S-KSH-□-□ (-2)

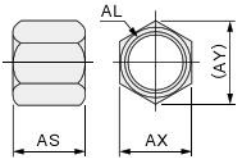

Symbol Model	AL	AS	AX	AY	Applicable shock absorbers			
					KSHJ	KSHY	KSHP	CS-KSHC
S-KSH-M4	M4×0.5	7.5	5.5	6.4	KSHJ4	—	—	CS-KSHC3
S-KSH-M6	M6×0.75	7	8	9.2	KSHJ6	—	KSHP6	CS-KSHC4
S-KSH-M6-L	M6×0.75	10	8	9.2	—	KSHY6	—	—
S-KSH-M8	M8×0.75	11	10	11.5	KSHJ8(-01,02)	KSHY8(-01,02)	KSHP8	CS-KSHC5
S-KSH-M8-11	M8×1	11	10	11.5	KSHJ8(-11,12)	KSHY8(-11,12)	KSHP6-11	CS-KSHC5-11
S-KSH-M10	M10×1	17	12	13.9	KSHJ10	KSHY10	KSHP10	CS-KSHC6
S-KSH-M12	M12×1	17	14	16.2	KSHJ12	KSHY12	KSHP12	CS-KSHC8
S-KSH-M14	M14×1.5	18	17	19.6	KSHJ14	KSHY14	KSHP14	CS-KSHC9
S-KSH-M16	M16×1.5	30	19	21.9	KSHJ16	KSHY16	KSHP16	CS-KSHC11
S-KSH-M18	M18×1.5	35	21	24.2	KSHJ18	—	KSHP18	—
S-KSH-M20	M20×1.5	35	24	27.7	KSHJ20	KSHY20	KSHP20	CS-KSHC14
S-KSH-M22	M22×1.5	40	27	31.2	KSHJ22	—	—	—
S-KSH-M25	M25×1.5	40	30	34.6	KSHJ25-01	—	KSHP25	CS-KSHC18
S-KSH-M25-11	M25×2	40	30	34.6	KSHJ25(-11,12)	—	—	—
S-KSH-M27	M27×1.5	40	36	41.6	KSHJ27(-01,02)	—	—	—
S-KSH-M27-11	M27×3	40	36	41.6	KSHJ27(-11,12)	—	—	—
S-KSH-M30	M30×1.5	40	36	41.6	KSHJ30	—	KSHP30	—
S-KSH-M33	M33×1.5	40	41	47.3	KSHJ33	—	—	—
S-KSH-M36	M36×1.5	50	46	53.1	KSHJ36	—	KSHP36	—
S-KSH-M42	M42×1.5	50	50	57.7	KSHJ42	—	KSHP42	—
S-KSH-M45	M45×1.5	60	55	63.5	KSHJ45	—	—	—
S-KSH-M48	M48×2	60	55	63.5	KSHJ48	—	—	—

Dimensions of Additional Parts (mm)

●Side mounting bracket: 2-KSH-□-□ (-2)

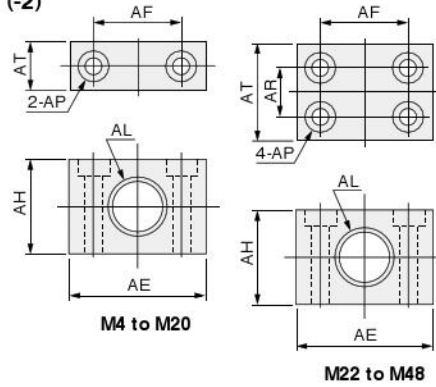

Symbol Model	AE	AF	AH	AL	AP	AR	AT	Applicable shock absorbers			
								KSHJ	KSHY	KSHP	CS-KSHC
2-KSH-M4	18	12	8	M4×0.5	φ3.4, φ6.5 Counter bore depth3.3	—	8	KSHJ4	—	—	CS-KSHC3
2-KSH-M6	18	12	10	M6×0.75	φ3.4, φ6.5 Counter bore depth3.3	—	8	KSHJ6	KSHY6	KSHP6	CS-KSHC4
2-KSH-M8	19	13	13	M8×0.75	φ3.4, φ6.5 Counter bore depth3.3	—	9	KSHJ8(-01,02)	KSHY8(-01,02)	KSHP8	CS-KSHC5
2-KSH-M8-11	19	13	13	M8×1	φ3.4, φ6.5 Counter bore depth3.3	—	9	KSHJ8(-11,12)	KSHY8(-11,12)	KSHP8-11	CS-KSHC5-11
2-KSH-M10	22	14	14	M10×1	φ3.4, φ6.5 Counter bore depth3.3	—	9	KSHJ10	KSHY10	KSHP10	CS-KSHC6
2-KSH-M12	25	16	18	M12×1	φ3.4, φ6.5 Counter bore depth3.3	—	9	KSHJ12	KSHY12	KSHP12	CS-KSHC8
2-KSH-M14	34	22	22	M14×1.5	φ4.5, φ8 Counter bore depth4.5	—	10	KSHJ14	KSHY14	KSHP14	CS-KSHC9
2-KSH-M16	38	25	25	M16×1.5	φ4.5, φ8 Counter bore depth4.5	—	12	KSHJ16	KSHY16	KSHP16	CS-KSHC11
2-KSH-M18	50	34	30	M18×1.5	φ6.5, φ11 Counter bore depth6.5	—	12	KSHJ18	—	KSHP18	—
2-KSH-M20	50	34	30	M20×1.5	φ9, φ14 Counter bore depth8.5	—	16	KSHJ20	KSHY20	KSHP20	CS-KSHC14
2-KSH-M22	60	44	35	M22×1.5	φ9, φ14 Counter bore depth8.5	19	35	KSHJ22	—	—	—
2-KSH-M25	60	44	35	M25×1.5	φ9, φ14 Counter bore depth8.5	19	35	KSHJ25-01	—	KSHP25	CS-KSHC18
2-KSH-M25-11	60	44	35	M25×2	φ9, φ14 Counter bore depth8.5	19	35	KSHJ25(-11,12)	—	—	—
2-KSH-M27	60	44	44	M27×1.5	φ9, φ14 Counter bore depth8.5	19	35	KSHJ27(-01,02)	—	—	—
2-KSH-M27-11	60	44	44	M27×3	φ9, φ14 Counter bore depth8.5	19	35	KSHJ27(-11,12)	—	—	—
2-KSH-M30	60	44	46	M30×1.5	φ9, φ14 Counter bore depth8.5	19	35	KSHJ30	—	KSHP30	—
2-KSH-M33	100	70	62	M33×1.5	φ18, φ26 Counter bore depth18	50	80	KSHJ33	—	—	—
2-KSH-M36	100	70	62	M36×1.5	φ18, φ26 Counter bore depth18	50	80	KSHJ36	—	KSHP36	—
2-KSH-M42	100	70	62	M42×1.5	φ18, φ26 Counter bore depth18	50	80	KSHJ42	—	KSHP42	—
2-KSH-M45	120	85	70	M45×1.5	φ22, φ32 Counter bore depth22	45	80	KSHJ45	—	—	—
2-KSH-M48	120	85	70	M48×2	φ22, φ32 Counter bore depth22	45	80	KSHJ48	—	—	—

MEMO

Handwriting practice area consisting of multiple horizontal dashed lines for text entry.

KSHJ

KSHY

KSHP

KSHC

Additional Parts

Limited Warranty

KOGANEI CORP. warrants its products to be free from defects in material and workmanship subject to the following provisions.

Warranty Period The warranty period is 180 days from the date of delivery.

Koganei Responsibility If a defect in material or workmanship is found during the warranty period, KOGANEI CORP. will replace any part proved defective under normal use free of charge and will provide the service necessary to replace such a part.

Limitations

- This warranty is in lieu of all other warranties, expressed or implied, and is limited to the original cost of the product and shall not include any transportation fee, the cost of installation or any liability for direct, indirect or consequential damage or delay resulting from the defects.

- KOGANEI CORP. shall in no way be liable or responsible for injuries or damage to persons or property arising out of the use or operation of the manufacturer's product.

- This warranty shall be void if the engineered safety devices are removed, made inoperative or not periodically checked for proper functioning.

- Any operation beyond the rated capacity, any improper use or application, or any improper installation of the product, or any substitution upon it with parts not furnished or approved by KOGANEI CORP., shall void this warranty.

- This warranty covers only such items supplied by KOGANEI CORP. The products of other manufacturers are covered only by such warranties made by those original manufacturers, even though such items may have been included as the components.

The specifications are subject to change without notice.

URL <http://www.koganei.co.jp>

E-mail: overseas@koganei.co.jp



KOGANEI CORPORATION

OVERSEAS DEPARTMENT

3-11-28, Midori-cho, Koganei City, Tokyo 184-8533, Japan
Tel: 81-42-383-7271 Fax: 81-42-383-7276

KOGANEI INTERNATIONAL AMERICA, INC.

39300 Civic Center Dr., Suite 280, Fremont, CA 94538, U.S.A.
Tel: 1-510-744-1626 Fax: 1-510-744-1676

SHANGHAI KOGANEI INTERNATIONAL TRADING CORPORATION

Room 2606-2607, Tongda Venture Building No.1, Lane 600, Tianshan Road,
Shanghai, 200051, China
Tel: 86-21-6145-7313 Fax: 86-21-6145-7323

TAIWAN KOGANEI TRADING CO., LTD.

Rm. 2, 13F., No88, Sec. 2, Zhongxiao E. Rd., Zhongzheng Dist., Taipei City 100,
Taiwan (ROC)
Tel: 886-2-2393-2717 Fax: 886-2-2393-2719

KOGANEI KOREA CO., LTD.

KT&G Cosmo Bldg., 3F, 40-13, Maesanno 2-ga, Paldal-gu, Suwon-si, Gyeonggi-do,
442-847, Korea
Tel: 82-31-246-0414 Fax: 82-31-246-0415

KOGANEI (THAILAND) CO., LTD.

3300/90, Tower B, Elephant Tower, 16th Fl., Phaholyothin Road, Chomphon,
Chatuchak, Bangkok 10900, Thailand
Tel: 66-2-937-4250 Fax: 66-2-937-4254

KOGANEI ASIA PTE. LTD.

12 Arumugam road #03-12, Lion Building B, 409958, Singapore
Tel: 65-6293-4512 Fax: 65-6293-4513