

# Linear Orifice<sup>®</sup> Protective shock absorbers KSHW Series



**Depend on Koganei shock absorbers to  
withstand their environments!**



# Linear Orifice<sup>®</sup> Protective shock absorbers KSHW series

\*"Linear Orifice" is a registered trademark of Koganei Corporation.

Solve problems by **absorbing impact in bad environments, such as cutting oil, water, or dust!**



## Machining Processes

Cutting oil countermeasures:

Fluorine packing

Machining chip countermeasures:

Equipped with filter



## Food processing machinery

Sanitary countermeasures:

H1 oil specifications

Rust-proofing countermeasures:

Stainless steel specifications

Dust countermeasures:

Equipped with filter

Wide range of variations.

**M8 to M20**

6 sizes in 14 models



KSHW8×5

KSHW10×6

KSHW12×6

KSHW14×8

KSHW16×8

KSHW20×10







Before selecting and using the products, please read all the "Safety Precautions" carefully to ensure proper product use.

The Safety Precautions described below are to help you use the product safely and correctly, and to prevent injury or damage to you, other people, and assets.

Be sure to observe these safety precautions together with the following safety regulations of ISO4414 (Pneumatic fluid power - General rules and safety requirements for systems and their components), and JIS B 8370 (General rules relating to systems).

The directions are ranked according to degree of potential danger or damage: "DANGER", "WARNING", "CAUTION" and "ATTENTION."

 DANGER	Indicates situations that can be clearly predicted as dangerous. Death or serious injury may result if the situation is not avoided. It could also result in damage or destruction of assets.
 WARNING	Indicates situations that, while not immediately dangerous, could become dangerous. Death or serious injury may result if the situation is not avoided. It could also result in damage or destruction of assets.
 CAUTION	Indicates situations that, while not immediately dangerous, could become dangerous. Failure to avoid the situation creates the risk of minor or semi-serious injury. It could also result in damage or destruction of assets.
 ATTENTION	It could also result in damage or destruction of assets. appropriate use of the product.

**■ This product was designed and manufactured for use in general industrial machinery.**

- When selecting and handling equipment, the system designer or another person with sufficient knowledge and experience should always read the "Safety Precautions", "catalog", "instruction manual", and other literature before commencing operation. Improper handling is dangerous.
- After reading the instruction manual, catalog, and other documentation, always place them in a location that allows easy availability for reference to users of this product.
- Whenever transferring or lending the product to another person, always attach the catalog, instruction manual, and other information to the product where they are easily visible in order to ensure that the new user can use the product safely and properly.
- The danger, warning and caution items listed under these "Safety Precautions" do not cover all possible contingencies. Read the catalog and instruction manual carefully, and always keep safety first.

 DANGER

- Do not use the product for the purposes listed below:
  1. Medical equipment related to maintenance or management of human lives or bodies.
  2. Machines or equipment designed for the purpose of moving or transporting people.
  3. Critical safety components in mechanical devices.
 This product has not been planned or designed for purposes that require high levels of safety. Using the product in any of the ways described above creates the risk of loss of human life.
- Do not use the product in locations with or near dangerous substances such as flammable or ignitable substances. This product is not explosion-proof. It could ignite or burst into flames.
- When mounting the product and workpiece, always make sure they are firmly supported and secured in place. Ensure the mounting material is strong enough. If the product falls over, is dropped, or breaks, it may result in injury.
- Never attempt to modify the product in any way. Doing so can cause an abnormal operation and create the risk of injury, etc.
- Never attempt inappropriate disassembly, assembly or repair of the product relating to basic construction, or to its performance or to functions. This can lead to injury, etc.
- While the product is in operation, avoid touching it with your hands or otherwise approaching too close. Also, do not mount shock absorbers or make adjustments while the equipment is in operation. The equipment may move suddenly, possibly resulting in injury.

 WARNING

- Do not use the product in excess of its specification range. Doing so creates the risk of product breakdown, loss of function, or damage. It could also drastically reduce operating life.
- The small screw on the back end of the shock absorber should never be loosened or removed. Oil may leak out of the shock absorber leading to a loss of functionality and resulting in injury.
- When conducting any kind of operation for the product, such as maintenance, inspection, repair, or replacement, always turn off the air supply and power to the equipment and make sure that the equipment is completely stopped.
- When mounting the product, always follow the handling instructions and precautions. Also when mounting the product, before operation, check that the mounting nut is tightened and not loose and then operate the product. If the mounting nut is loose, etc., this will result in damage to the equipment and accidents.
- Do not allow the product to be thrown into fire. The product could explode, ignite, and/or release toxic gases.

- Do not apply a load to the product, or place other objects on it. It could lead to damaged or broken products that result in degraded performance, function stops, etc.
- If the product has not been used for over 30 days, it is possible that the contacting parts may have become stuck, leading to abnormal operation at impact. Check for proper operation a minimum of once every 30 days.
- Do not use the product at the beach in direct sunlight, near mercury lamps, or near equipment that generates ozone. Ozone causes rubber components to deteriorate resulting in reduced performance, or a limitation or stop of functions.

 CAUTION

- Do not use the product in locations subject to direct sunlight (ultraviolet radiation); in locations subject to high temperature or salt; or if the atmosphere or media contains organic solvents, phosphate ester type hydraulic oil, sulfur dioxide gas, chlorine gas, acids, etc. It could lead to early shutdown of some functions, a sudden degradation of performance, and a reduced operating life. For information about materials, see Major Parts and Materials.
- When installing the product, be sure to allow adequate work space around it. Failure to do so will make it more difficult to conduct daily inspections or maintenance, which could eventually lead to system shutdown or damage to the product.
- When transporting or mounting a heavy product, firmly support the product using a lift or support, or use multiple people to ensure personal safety. Also, wear protective gloves and use safety shoes etc. for protection as necessary.
- Always post an "operations in progress" sign for installations, adjustments, or other operations, to avoid unintentional supplying of air or electrical power, etc. Unintentional supplying of air or electrical power can cause the equipment to operate and may result in injury.
- Never apply lubrication to the product sliding parts. This leads to changes in the physical properties and deterioration of the materials used, resulting in reduced functionality.
- As a means to prevent vibration, do not use the product at a high frequency that exceeds the value in the catalog. It could drastically reduce the product's operating life.
- When using the shock absorber, gradually increase the speed of the impact object. Suddenly increasing the speed when using the shock absorber may damage the device or injure someone.

### ATTENTION

- Whenever considering use of this product in situations or environments not specifically noted in the catalog or instruction manual, or in applications where safety is an important requirement such as in aircraft equipment, combustion equipment, leisure equipment, safety equipment, and other places where human life or assets may be greatly affected, take adequate safety precautions such as allowing plenty of margin for ratings and performance, or fail-safe measures. Contact the sales department of Koganei regarding use in such applications.
- When the product can no longer be used, or is no longer necessary, dispose of it appropriately, according to the "Law Regarding the Disposal and Cleaning of Waste" or other local governmental rules and regulations, as industrial waste.
- The product can exhibit degraded performance and function over its operating life. Always conduct daily inspections and confirm that all requisite system functions are satisfied, to prevent accidents from happening.
- When handling the product, wear protective gloves, safety glasses, safety shoes, and other protective clothing.
- The maximum absorption in the specifications are for a normal temperature (20 to 25°C [68 to 77°F]). Be aware that performance and characteristics change depending on the operating temperature.
- The shock absorber's absorption capacity changes depending on the speed of the impacting object. Use the product within the ranges of the selection graphs.
- For inquiries about the product, consult your nearest Koganei sales office or Koganei Overseas Department. The addresses and telephone numbers are shown on the back cover of this catalog.

### Other

- Always observe the following items.
- 1. When using this product in a system, use only genuine Koganei parts or equivalent (recommended) parts. When conducting maintenance and repairs, always use genuine Koganei parts or compatible parts (recommended parts). Always observe the prescribed methods and procedures.
- 2. Never attempt unauthorized disassembly or assembly of the product relating to its basic construction, its performance, or its functions.

Koganei shall not be held responsible for any problems that occur as a result of these items not being properly observed.

### Warranty and General Disclaimer

#### 1. Warranty Period

Koganei warrants this product for a period of no more than 1 year from delivery.

\* However, some products have a 2-year warranty; contact your nearest Koganei sales office or the Koganei Technical Service Center for details.

#### 2. Scope of Warranty and General Disclaimer

- (1) When a product purchased from Koganei or from an authorized Koganei distributor malfunctions during the warranty period in a way that is found to be attributable to Koganei responsibility, Koganei will repair or replace the product free of charge. Even if a product is still within the warranty period, its durability is determined by its operation cycles and other factors. Contact your nearest Koganei sales office or the Koganei overseas department for details.
- (2) The Koganei product warranty covers only the product itself. Therefore, Koganei is not responsible for incidental losses (repair of the product, various expenses required for replacement, etc.) caused by breakdown, loss of function, or loss of performance of Koganei products.
- (3) Koganei shall not be held responsible for any losses or for any damage to other machinery caused by breakdown, loss of function, or loss of performance of Koganei products.
- (4) Koganei shall not be held responsible for any losses due to use or storage of the product in a way that is outside of the product specifications prescribed in Koganei catalogs and the instruction manual, and/or due to actions that violate the mounting, installation, adjustment, maintenance and other safety precautions.
- (5) Koganei shall not be held responsible for any losses caused by breakdown of the product due to factors outside the responsibility of Koganei, including but not limited to fire, natural disaster, the actions of third parties, and intentional actions or errors by you.



### General precautions

1. The product is specified as dust-proof and drip-proof, however, the usage environment and conditions affect its service life. The expected durability may not be achieved, depending on the type and amount of dust and liquid to which the shock absorber is subjected. We recommend doing confirmation tests in advance.
2. Handle the shock absorbers so they are not scratched or dented. The drip-proof and dust-proof performance is reduced if the piston rod is scratched. Also, installing and removing the shock absorbers becomes more difficult if the body threads are scratched.
3. Shock absorbers have reached the end of their service life if the piston rod can no longer be pushed to the stroke end while in use. Stop using the shock absorber and replace it. Continuing to use a shock absorber while it cannot absorb shocks could damage it, as well as damage the base equipment itself.



### Installation

1. Keep the angle of eccentricity, resulting from the load direction and the axis of the shock absorber, under the specified values on pages 17 to 19. If an eccentric load exceeding the specifications is applied, it could result in breakage or impaired returns. If there is concern that an eccentric load exceeding the specified values will be applied, install a guide, or similar mechanism.
2. Two or more shock absorbers can be mounted in parallel, to boost absorption capacity. In such an arrangement, however, be careful to ensure that the load is evenly distributed to each shock absorber.
3. To adjust the capacity with the stroke, adjust the stopper nut (-S) or add an external stopper.
4. The small screw on the back end of the shock absorber should never be loosened or removed. Oil may leak out of the shock absorber leading to a loss of functionality and resulting in damage to the equipment and accidents.
5. When mounting the shock absorber, always use the following maximum tightening torque guidelines. Tightening using excessive force may result in damage.

Model	N·m [ft·lbf]	
	Maximum tightening torque	
KSHW8×5-01,-02,-11,-12	2.5 [1.844]	
KSHW10×6-01,02	6.5 [4.794]	
KSHW12×6-01,02	8.0 [5.901]	
KSHW14×8-01,02	12.0 [8.851]	
KSHW16×8-01,02	20.0 [14.752]	
KSHW20×10-01,02	30.0 [22.128]	

6. Ensure that the hardness of the surface directly impacting the piston rod of the shock absorber is over HRC40 hardness.
7. Be aware that performance and characteristics change depending on the operating temperature.

■ How to select shock absorbers

1. Confirm the thrust

Confirm the thrust to be used, and then check for prospective shock absorbers according to the recommended cylinder diameter chart on page 5. If you use a shock absorber that is smaller than the recommended size, you may not get the expected operation cycles.

2. Confirm the kinetic energy

Confirm I and II below, and then check pages 14 to 16 for the selection graphs for prospective shock absorbers from [1. Confirm the thrust]. (\*)

I Impact object mass:  $m$  [kg [lb]]

II Impact speed:  $v$  [m/s [ft/sec]]

Because "v" is the impact speed, not the average speed, when using a cylinder,

$$v = m [\text{cylinder stroke}] \div s [\text{operating time}] \times 2$$

Select a model in which I and II fit within the range enclosed by the capacity curves.

If multiple models are applicable, use the model that is closest to both the capacity curves and the operating conditions. The further the model you select is from the capacity curves and the operating conditions, the slower it will tend to be.

3. Confirm other specifications

Confirm that such specifications as the maximum operating frequency, maximum absorption capacity per unit of time, angle of eccentricity, and operating temperature range are within the range for the shock absorber that you selected.

\* The value for the kinetic energy,  $E$ , can be found by doing the following calculation. However, the shock absorber's capacity for absorption changes depending on the impact speed. When the shock absorber is doing low-speed operations, it has less drag than when it is doing high-speed operations.

The maximum absorption capacity that is noted in the specifications is reached only at the maximum impact speed.

Therefore, do not choose a shock absorber by comparing  $E$  to the maximum absorption capacity; confirm the capacity using the selection graph.

$$E = \frac{1}{2} mv^2$$

$E$ : Kinetic energy (J [ft · lbf])

$m$ : Impact object mass [kg [lb]]

$v$ : Impact speed (m/s [ft/sec])

Range in the selection graph

Vertical axis range :

$$\text{Maximum impact speed} \geq v \text{ Impact speed (operating condition)}$$

Horizontal axis range :

$$\text{Shock absorber's maximum absorption capacity at the impact speed (} v = m/s [\text{ft/sec}] \text{)} \geq \text{Kinetic energy } E \text{ (operating condition)}$$

Calculating the thrust energy is not necessary because the size of the shock absorber is limited by the thrust in step 1.

■ Example of selecting a shock absorber

[Operating conditions]

① Bore size of the cylinder being used:  $\phi 16$  [0.630]

② Cylinder stroke: 100 mm [3.9 in.] = 0.1 m [0.328 ft]

③ Pressure applied to the cylinder: 0.6 MPa [87 psi]

④ Cylinder's operating time: 0.4 s

⑤ Impact object mass: 7 kg [15.432 lb]

1. Confirm the thrust

Either calculate or find the thrust in the cylinder thrust table on page 10.

The cylinder thrust based on ① and ③ is about 121 N.

Cylinder thrust	100.5 N [22.6 lbf]	<	120.6 N [27.1 lbf]	<	126 N [28.3 lbf]
Cylinder bore size	$\phi 16$ [0.630]		$\phi 16$ [0.630]		$\phi 20$ [0.787]
Applied pressure	0.5 MPa [73 psi]		0.6 MPa [87 psi]		0.4 MPa [58 psi]

As mentioned above, although the cylinder being used is  $\phi 16$  [0.630], the pressure applied to the cylinder exceeds 0.5 MPa [73 psi], so consider the  $\phi 20$  [0.787] cylinder (lower than 0.4 MPa [58 psi]) and check the table of recommended cylinder bore sizes on page 10.

The following are prospective models.

- KSHW10×6
- KSHW12×6
- KSHW14×8
- KSHW16×8

2. Confirm the kinetic energy

I The impact object mass  $m = 7$  kg [15.432 lb] from ⑤

II Find the impact speed,  $v$ , from ② and ④.

$$v = \textcircled{2} 0.1 \text{ m [0.328 ft]} \div \textcircled{4} 0.4 \text{ s} \times 2 = 0.5 \text{ m/s [1.640 ft/sec]}$$

According to the selection graphs on pages 14 to 16, the shock absorber with the optimum absorption capacity for operating conditions is KSHW12×6-02.

$$1 \text{ kg} = 35.274 \text{ oz} \\ 1 \text{ m/s} = 3.280 \text{ ft/sec}$$

● KSHW10×6

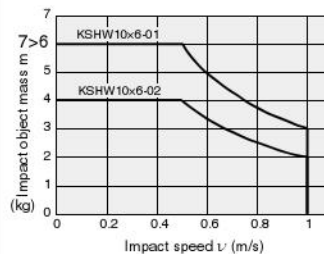

● KSHW12×6

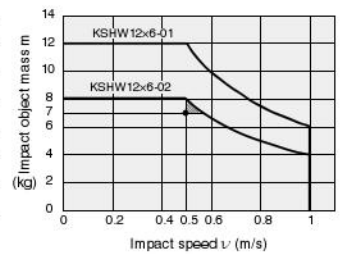

● KSHW14×8

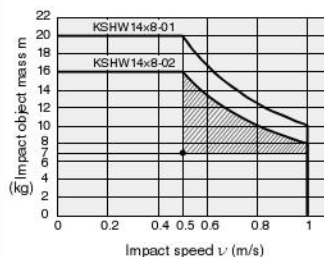

- KSHW10×6 ... Inadequate absorption capacity
- KSHW12×6-01 ... KSHW12×6-02 is closer to the usage conditions and capacity curves.
- The absorption capacities for all of the other shock absorbers are higher than that of KSHW12×6-02, so they do not fall within the operating conditions and capacity curves.

3. Confirm other specifications

Verify that other operating conditions, such as the maximum operating frequency, maximum absorption capacity per unit of time, angle of eccentricity, and operating temperature range, are within the specified ranges for KSHW12×6-02.

## Selection Guideline

### ■ Recommended cylinder bores

Model	Cylinder bore size									
	φ8 [0.315]	φ10 [0.394]	φ12 [0.472]	φ16 [0.630]	φ20 [0.787]	φ25 [0.984]	φ32 [1.260]	φ40 [1.575]	φ50 [1.969]	
<b>KSHW8×5</b>	◇	○	○	○						
<b>KSHW10×6</b>		◇	○	○	○					
<b>KSHW12×6</b>			◇	○	○	○				
<b>KSHW14×8</b>				◇	○	○	○			
<b>KSHW16×8</b>					◇	○	○	○		
<b>KSHW20×10</b>						◇	○	○	○	

◇ : over 0.3 MPa [44 psi]    ○ : under 0.5 MPa [73 psi]    ○ : under 0.4 MPa [58 psi]

Note: If you use a shock absorber that is smaller than the recommended size, it could be damaged and get fewer than the guaranteed operation cycles.

### ■ Cylinder thrust

Cylinder bore size	Pressure area mm <sup>2</sup> [in <sup>2</sup> ]	Air pressure MPa [psi]								
		0.1 [15]	0.2 [29]	0.3 [44]	0.4 [58]	0.5 [73]	0.6 [87]	0.7 [102]	0.8 [116]	0.9 [131]
φ 8 [0.315]	50.3 [0.078]	5	10.1	15.1	20.1	25.1	30.2	35.2	40.2	45.2
φ 10 [0.394]	78.5 [0.122]	7.9	15.7	23.6	31.4	39.3	47.1	55	62.8	70.7
φ 12 [0.472]	113 [0.2]	11.3	22.6	33.9	45.2	56.5	67.9	79.2	90.5	101.8
φ 16 [0.630]	201 [0.3]	20.1	40.2	60.3	80.4	100.5	121	141	161	181
φ 20 [0.787]	314 [0.5]	31.4	62.8	94.2	126	157	188	220	251	283
φ 25 [0.984]	491 [0.8]	49.1	98.2	147	196	245	295	344	393	442
φ 32 [1.260]	804 [1.2]	80.4	161	241	322	402	483	563	643	724
φ 40 [1.575]	1257 [2]	126	251	377	503	628	754	880	1005	1131
φ 50 [1.969]	1963 [3]	196	393	589	785	982	1178	1374	1571	1767

**Precautions when using the selection graph**

1. Selection graph data is calculated with 0.5 MPa [73 psi] for the air pressure used in cylinders.
2. The values on the selection graphs are for room temperature (20 to 25°C [68 to 77°F]). Be aware that performance and characteristics change depending on the operating temperature.
3. Select a shock absorber that is under and near the capacity curve.

■ Selection graph

1 kg = 35.274 oz  
1 m/s = 3.280 ft/sec

● KSHW8×5

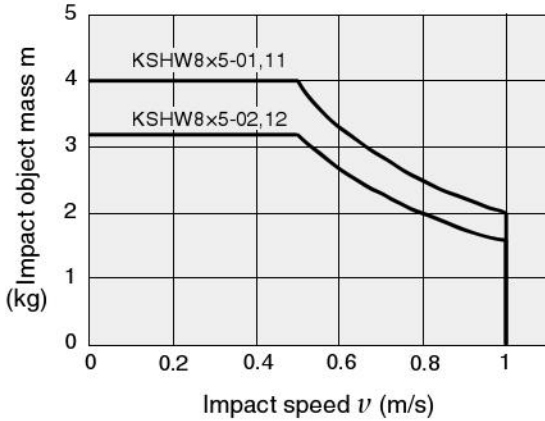

● KSHW10×6

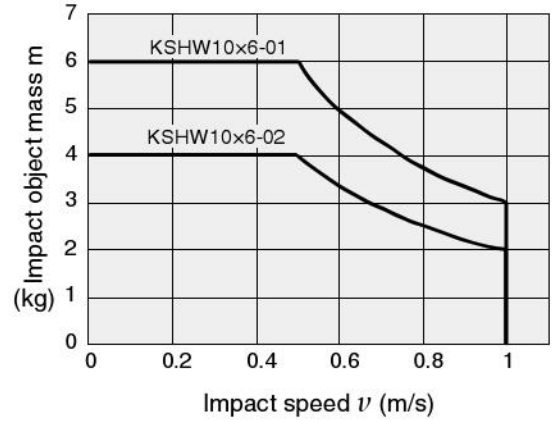

● KSHW12×6

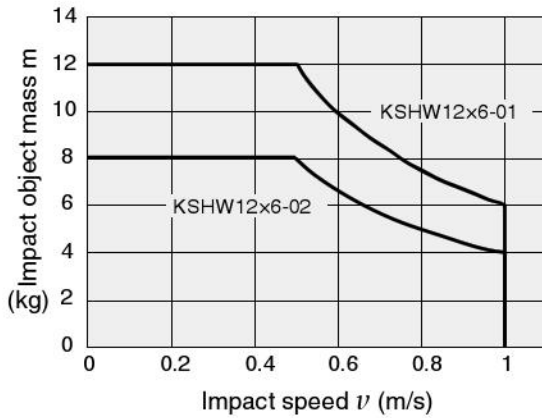

● KSHW14×8

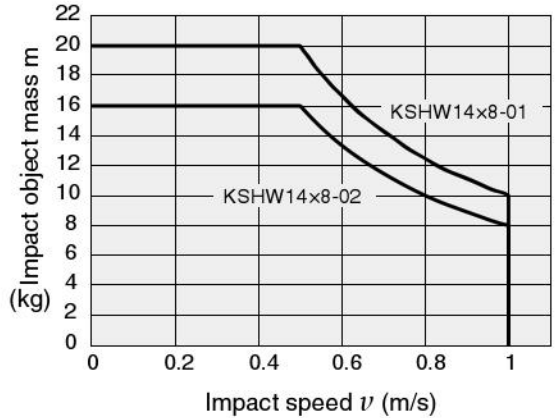

● KSHW16×8

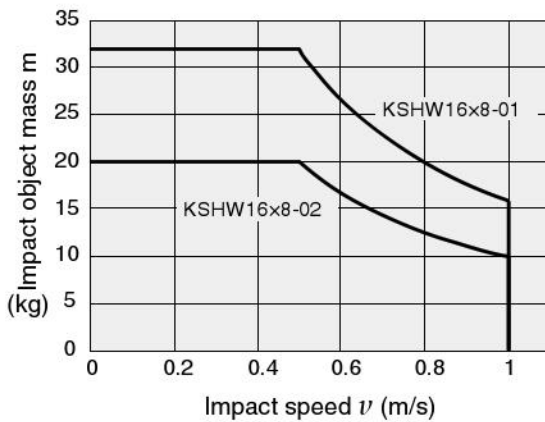

● KSHW20×10

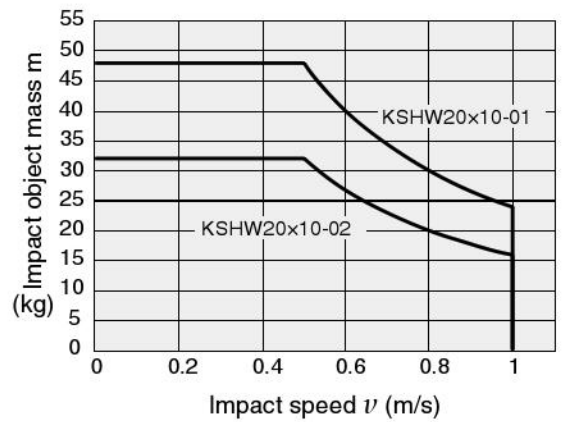

# Linear Orifice Protective Shock Absorbers

KSHW series



## Specifications

Item	Model	KSHW8×5-01,-11	KSHW8×5-02,12	KSHW10×6-01	KSHW10×6-02
Maximum absorption capacity	J [ft·lbf]	1 [0.738]	0.8 [0.590]	1.5 [1.106]	1 [0.738]
Absorption stroke	mm [in.]	5 [0.197]		6 [0.236]	
Impact speed range	m/s [ft/sec]	0.1 to 1.0 [0.328 to 3.280]			
Maximum operating frequency	cycle/min	60			
Maximum absorption per unit of time	J/min	20		30	
Spring return force <sup>Note 1</sup>	N [lbf]	9 [2.023]		11 [2.473]	
Deflection angle		1° or less			
Operating temperature range <sup>Note 2</sup>	°C [°F]	0 to 60 [32 to 140]			

Item	Model	KSHW12×6-01	KSHW12×6-02	KSHW14×8-01	KSHW14×8-02
Maximum absorption capacity	J [ft·lbf]	3 [2.213]	2 [1.475]	5 [3.688]	4 [2.950]
Absorption stroke	mm [in.]	6 [0.236]		8 [0.315]	
Impact speed range	m/s [ft/sec]	0.1 to 1.0 [0.328 to 3.280]			
Maximum operating frequency	cycle/min	60			
Maximum absorption per unit of time	J/min	45		60	
Spring return force <sup>Note 1</sup>	N [lbf]	10 [2.248]		13 [2.923]	
Deflection angle		1° or less			
Operating temperature range <sup>Note 2</sup>	°C [°F]	0 to 60 [32 to 140]			

Item	Model	KSHW16×8-01	KSHW16×8-02	KSHW20×10-01	KSHW20×10-02
Maximum absorption capacity	J [ft·lbf]	8 [5.901]	5 [3.688]	12 [8.851]	8 [5.901]
Absorption stroke	mm [in.]	8 [0.315]		10 [0.394]	
Impact speed range	m/s [ft/sec]	0.1 to 1.0 [0.328 to 3.280]			
Maximum operating frequency	cycle/min	40			
Maximum absorption per unit of time	J/min	80		120	
Spring return force <sup>Note 1</sup>	N [lbf]	13 [2.923]		21.5 [4.833]	
Deflection angle		1° or less			
Operating temperature range <sup>Note 2</sup>	°C [°F]	0 to 60 [32 to 140]			

Note 1: The spring return force is the force of the piston rod returning after a full stroke, it is not consistent so cannot be used as a function.

Note 2: The absorption capacity of shock absorbers increases and decreases depending on speed and ambient temperature.  
Always use one that is within the range shown by the capacity curve on the selection graphs on page ⑥.

## Mass

Model	Body <sup>Note 3</sup>	Weight of additional parts			
		Mounting nut (per piece)		Stopper nut	
		Mild steel, nickel plated	Stainless steel	Mild steel, nickel plated	Stainless steel
KSHW8×5-01,-02,-11,-12	10 [0.353]	0.6 [0.021] (0.9 [0.032]) <sup>Note 4</sup>	0.6 [0.021] (0.9 [0.032])	4 [0.141]	4 [0.141]
KSHW10×6-01,-02	21 [0.741]	1.2 [0.042]	1.2 [0.042]	7 [0.247]	7 [0.247]
KSHW12×6-01,-02	34 [1.199]	1.9 [0.067]	1.9 [0.067]	8 [0.282]	9 [0.317]
KSHW14×8-01,-02	52 [1.834]	4 [0.141]	4.5 [0.159]	15 [0.529]	16 [0.564]
KSHW16×8-01,-02	68 [2.399]	6.6 [0.233]	7.5 [0.265]	28 [0.988]	31 [1.093]
KSHW20×10-01,-02	139 [4.9]	12.2 [0.430]	13 [0.459]	55 [1.940]	57 [2.011]

Calculation example: The weight of the KSHW10×6-01-PS (with stainless steel mounting nut and stainless steel stopper nut) is  
21 [0.741] + 1.2 [0.042] × 2 + 7 [0.247] = 30.4 g [1.072 oz].

Note 3: Body weight is the weight of the shock absorber only. The mounting nut weight is not included.

Note 4: (0.9 [0.032]) is the weight of the mounting nut for the KSHW8×5-11 and -12.

# Inner Construction and Major Parts

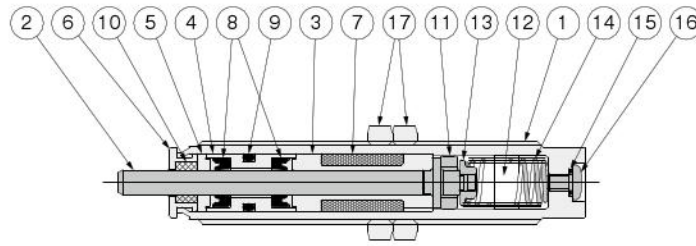

No.	Name	Material
①	Unit	Stainless steel
②	Piston rod	Special steel
③	Sleeve	Copper alloy
④	Seal	Copper alloy
⑤	Bearing	Copper alloy
⑥	Plug	Stainless steel
⑦	Accumulator	Fluoro rubber
⑧	Rod packing	Fluoro rubber

No.	Name	Material
⑨	O-ring	Fluoro rubber
⑩	Filter	Resin
⑪	Piston ring	Stainless steel
⑫	Oil	Special oil
⑬	Collar <sup>Note 1</sup>	Stainless steel
⑭	Spring	Spring steel
⑮	O-ring	Fluoro rubber
⑯	Screw	Mild steel (zinc plated)
⑰	Mounting nut <sup>Note 2</sup>	Mild steel (nickel plated) or stainless steel

Note 1: KSHW8 is copper alloy, KSHW10 and 12 are sintered metal

Note 2: The material can be selected.

## Order Codes

**KSHW** [ ] - [ ] - [ ]

**Thread pitch and absorption capacity**  
**01**: For heavy loads  
**02**: For light loads  
**11**: For heavy loads with different thread pitches  
**12**: For light loads with different thread pitches  
 (11 and 12 are set for 8x5 only, M8x1)

**Body thread size x Stroke**  
**8x5** ··· **M8x0.75**  
 5 mm [0.197 in.] stroke

**14x8** ··· **M14x1.5**  
 8 mm [0.315 in.] stroke

**10x6** ··· **M10x1**  
 6 mm [0.236 in.] stroke

**16x8** ··· **M16x1.5**  
 8 mm [0.315 in.] stroke

**12x6** ··· **M12x1**  
 6 mm [0.236 in.] stroke

**20x10** ··· **M20x1.5**  
 10 mm [0.394 in.] stroke

**Mounting nut and stopper nut**  
**Blank**: 2 mounting nuts (mild steel, nickel plated)  
**S**: 2 mounting nuts + 1 stopper nut (mild steel, nickel plated)  
**P**: 2 mounting nuts (stainless steel)  
**PS**: 2 mounting nuts + 1 stopper nut (stainless steel)

**KSHW Series**  
**Linear Orifice**  
**Protective Shock**  
**Absorbers**

## Additional Parts

● Hex nut (stainless) (1 bag, 10 pcs.)

**PN - KSH - M** [ ] - [ ]

**Thread pitches applicable to M8 only**  
**Blank**: M8x0.75  
**11**: M8x1.0

**Body thread size**  
**8**: For KSHW8  
**10**: For KSHW10  
**12**: For KSHW12  
**14**: For KSHW14  
**16**: For KSHW16  
**20**: For KSHW20

● Stopper nut (stainless)

**PS - KSH - M** [ ] - [ ]

**Thread pitches applicable to M8 only**  
**Blank**: M8x0.75  
**11**: M8x1.0

**Body thread size**  
**8**: For KSHW8  
**10**: For KSHW10  
**12**: For KSHW12  
**14**: For KSHW14  
**16**: For KSHW16  
**20**: For KSHW20

● Hex nut (mild steel, nickel plated) (1 bag, 10 pcs.)

**N - KSH - M** [ ] - [ ]

**Thread pitches applicable to M8 only**  
**Blank**: M8x0.75  
**11**: M8x1.0

**Body thread size**  
**8**: For KSHW8  
**10**: For KSHW10  
**12**: For KSHW12  
**14**: For KSHW14  
**16**: For KSHW16  
**20**: For KSHW20

● Stopper nut (mild steel, nickel plated)

**S - KSH - M** [ ] - [ ]

**Thread pitches applicable to M8 only**  
**Blank**: M8x0.75  
**11**: M8x1.0

**Body thread size**  
**8**: For KSHW8  
**10**: For KSHW10  
**12**: For KSHW12  
**14**: For KSHW14  
**16**: For KSHW16  
**20**: For KSHW20

# Dimensions (mm [in.])

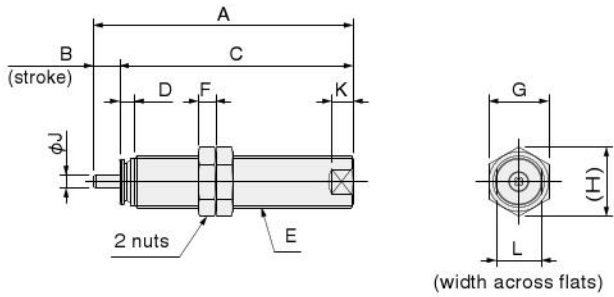

Model	Symbol	A	B	C	D	E	F	G	H	J	K	L
KSHW8X5(C)-01,-02		44 [1.732]	5 [0.197]	39 [1.535]	3.5 [0.138]	M8×0.75	2 [0.079]	10 [0.394]	11.5 [0.453]	2.5 [0.098]	3 [0.118]	7 [0.276]
KSHW8X5(C)-11,-12		44 [1.732]	5 [0.197]	39 [1.535]	3.5 [0.138]	M8×1	3 [0.118]	10 [0.394]	11.5 [0.453]	2.5 [0.098]	3 [0.118]	7 [0.276]
KSHW10X6(C)-01,-02		56.5 [2.224]	6 [0.236]	50.5 [1.988]	3.5 [0.138]	M10×1	3 [0.118]	12 [0.472]	13.9 [0.547]	3 [0.118]	5 [0.197]	8.5 [0.335]
KSHW12X6(C)-01,-02		60.5 [2.382]	6 [0.236]	54.5 [2.146]	3.5 [0.138]	M12×1	4 [0.157]	14 [0.551]	16.2 [0.638]	3 [0.118]	5 [0.197]	10.5 [0.413]
KSHW14X8(C)-01,-02		70 [2.756]	8 [0.315]	62 [2.441]	4 [0.157]	M14×1.5	5 [0.197]	17 [0.669]	19.6 [0.772]	4 [0.157]	5 [0.197]	12 [0.472]
KSHW16X8(C)-01,-02		70 [2.756]	8 [0.315]	62 [2.441]	4 [0.157]	M16×1.5	7 [0.276]	19 [0.748]	21.9 [0.862]	4 [0.157]	7 [0.276]	13 [0.512]
KSHW20X10(C)-01,-02		86 [3.386]	10 [0.394]	76 [2.992]	4 [0.157]	M20×1.5	8 [0.315]	24 [0.945]	27.7 [1.091]	5 [0.197]	7 [0.276]	17 [0.669]

## Additional Parts Dimensions (mm [in.])

### ● Hexagon nut

PN-KSH-M□-□

N-KSH-M□-□

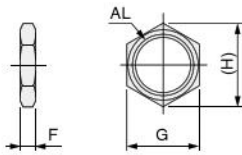

Model	Symbol	AL	F	G	H
PN-KSH-M8	M8×0.75	2 [0.079]	10 [0.394]	11.5 [0.453]	
N-KSH-M8					
PN-KSH-M8-11	M8×1	3 [0.118]	10 [0.394]	11.5 [0.453]	
N-KSH-M8-11					
PN-KSH-M10	M10×1	3 [0.118]	12 [0.472]	13.9 [0.547]	
N-KSH-M10					
PN-KSH-M12	M12×1	4 [0.157]	14 [0.551]	16.2 [0.638]	
N-KSH-M12					
PN-KSH-M14	M14×1.5	5 [0.197]	17 [0.669]	19.6 [0.772]	
N-KSH-M14					
PN-KSH-M16	M16×1.5	7 [0.276]	19 [0.748]	21.9 [0.862]	
N-KSH-M16					
PN-KSH-M20	M20×1.5	8 [0.315]	24 [0.945]	27.7 [1.091]	
N-KSH-M20					

### ● Stainless steel stopper nut

PS-KSH-M□-□

S-KSH-M□-□

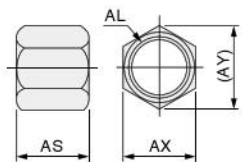

Model	Symbol	AL	AS	AX	AY
PS-KSH-M8	M8×0.75	11 [0.433]	10 [0.394]	11.5 [0.453]	
S-KSH-M8					
PS-KSH-M8-11	M8×1	11 [0.433]	10 [0.394]	11.5 [0.453]	
S-KSH-M8-11					
PS-KSH-M10	M10×1	17 [0.669]	12 [0.472]	13.9 [0.547]	
S-KSH-M10					
PS-KSH-M12	M12×1	17 [0.669]	14 [0.551]	16.2 [0.638]	
S-KSH-M12					
PS-KSH-M14	M14×1.5	18 [0.709]	17 [0.669]	19.6 [0.772]	
S-KSH-M14					
PS-KSH-M16	M16×1.5	30 [1.181]	19 [0.748]	21.9 [0.862]	
S-KSH-M16					
PS-KSH-M20	M20×1.5	35 [1.378]	24 [0.945]	27.7 [1.091]	
S-KSH-M20					

The product is specified as dust-proof and drip-proof, however, the usage environment and conditions affect its service life.

At Koganei, we have confirmed 1,000,000 operation cycles using the durability test described below.

The expected durability may not be achieved, depending on the type and amount of dust and liquid to which the shock absorber is subjected.

We recommend doing confirmation tests in advance.

## ● Testing procedure

As shown in the diagram on the right, a space was formed on the stroke end of the shock absorber to collect liquid or dust.

We confirmed that the damage or abnormalities listed below did not occur.

- Oil leakage
- Piston rod return failure
- Piston rod stroke abnormality (Stroke not reaching end)
- Loose plug or ejection of internal parts
- Extreme reduction in stroke due to occurrence of drag

## ● Testing conditions

Operating frequency: 30 cycle/min

Types of liquid and dust

- ① Tap water
- ② Water-based cutting fluid: Daphne Alpha Cool EW (30x dilution)
- ③ Turbine oil: Mobile DTE Oil Light
- ④ Dust: JIS Test Powder 1 (1 type)

## ● Overview of test equipment for drip-proof and dust-proof performance

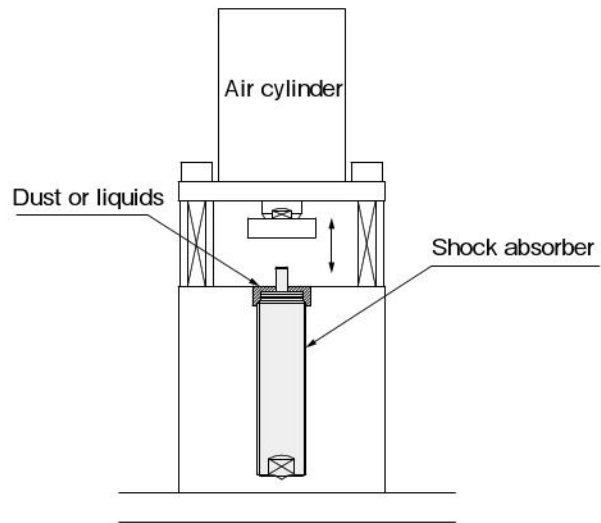

# Limited Warranty

KOGANEI CORP. warrants its products to be free from defects in material and workmanship subject to the following provisions.

**Warranty Period** The warranty period is 180 days from the date of delivery.

**Koganei Responsibility** If a defect in material or workmanship is found during the warranty period, KOGANEI CORP. will replace any part proved defective under normal use free of charge and will provide the service necessary to replace such a part.

**Limitations**

- This warranty is in lieu of all other warranties, expressed or implied, and is limited to the original cost of the product and shall not include any transportation fee, the cost of installation or any liability for direct, indirect or consequential damage or delay resulting from the defects.

- KOGANEI CORP. shall in no way be liable or responsible for injuries or damage to persons or property arising out of the use or operation of the manufacturer's product.

- This warranty shall be void if the engineered safety devices are removed, made inoperative or not periodically checked for proper functioning.

- Any operation beyond the rated capacity, any improper use or application, or any improper installation of the product, or any substitution upon it with parts not furnished or approved by KOGANEI CORP., shall void this warranty.

- This warranty covers only such items supplied by KOGANEI CORP. The products of other manufacturers are covered only by such warranties made by those original manufacturers, even though such items may have been included as the components.

The specifications are subject to change without notice.

URL <http://www.koganei.co.jp>

E-mail: [overseas@koganei.co.jp](mailto:overseas@koganei.co.jp)



## KOGANEI CORPORATION

### OVERSEAS DEPARTMENT

3-11-28, Midori-cho, Koganei City, Tokyo 184-8533, Japan  
Tel: 81-42-383-7271 Fax: 81-42-383-7276

### KOGANEI International America, Inc.

48860 Milmont Drive, Suite 108C Fremont, CA 94538, U.S.A  
TEL: (+1)510-744-1626 FAX: (+1)510-744-1676

### SHANGHAI KOGANEI INTERNATIONAL TRADING CORPORATION

Rm2606-2607, Tongda Venture Building NO.1 Lane 600, Tiانشan Road, Shanghai, China  
TEL: (+86)021-6145-7313 FAX: (+86)021-6145-7323

### TAIWAN KOGANEI TRADING CO., LTD

Pm 2, 16F., No88, Sec 2, Zhongxiao E. Rd., ZhongZheng Dist., Taipei City 10050, Taiwan (ROC)  
TEL: (+886)02-2393-2717 FAX: (+886)02-2393-2719

### KOGANEI KOREA CO., LTD

A-3001, Heungdeok IT Valley Bldg., Heungdeok 1-ro, 13, Giheung-gu, Yongin-si, Gyeonggi-do,  
446-908, KOREA  
TEL: (+82)31-246-0414 FAX: (+82)31-246-0415

### KOGANEI (THAILAND) CO., LTD

555 Rasa Tower I, Unit 1207, 1202, 12th floor, Phaholyothin Road, Chatuchak, Chatuchak,  
Bangkok 10900 Thailand  
TEL: (+66)02-513-1228 FAX: (+66)02-513-1232

### KOGANEI ASIA PTE. LTD.

69 Ubi Road 1, #05-18 Oxley Bizhub Singapore 408731  
TEL: (+65)6293-4512 FAX: (+65)6293-4513