

# SPEED CONTROLLERS KSC SERIES

Rc1/8 ~ Rc1

- Easy to adjust flow rate.
- Maintain stable flow rate.
- Compact and easy mounting.

## Symbol

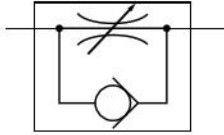

## Specifications

Item	Model	KSC11	KSC22	KSC21	KSC31	KSC41	KSC6	KSC8
Port size	Rc	1/8	1/4		3/8	1/2	3/4	1
Effective area	mm <sup>2</sup>	5.5 [0.31]	10 [0.56]	32 [1.78]	38 [2.11]	38 [2.11]	67 [3.72]	90 [5]
	[Cv]	3.0 [0.17]	6.5 [0.36]	22 [1.22]	22 [1.22]	22 [1.22]	62 [3.44]	103 [5.72]
Operating pressure range	MPa [psi.]	0.9 [131]						
Proof pressure	MPa [psi.]	1.3 [189]						
Cracking pressure	MPa [psi.]	0.06 [8.7]	0.02 [2.9]				0.01 [1.5]	
Operating temperature range	°C [°F]	5 ~ 60 [41 ~ 140]						
Mass	g [oz.]	90 [3.17]	130 [4.59]	420 [14.8]			960 [33.9]	880 [31.0]
Body material		Zinc die-casting			Aluminum die-casting			

## Order Codes



**Model**  
 KSC11  
 KSC22 KSC41  
 KSC21 KSC6  
 KSC31 KSC8

**Non-ion specification**  
 Blank — Standard specification  
 NCU — Non-ion specification

## Inner Construction and Major Parts

### ● KSC11

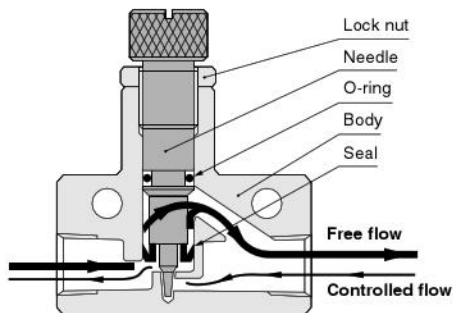

### ● KSC22

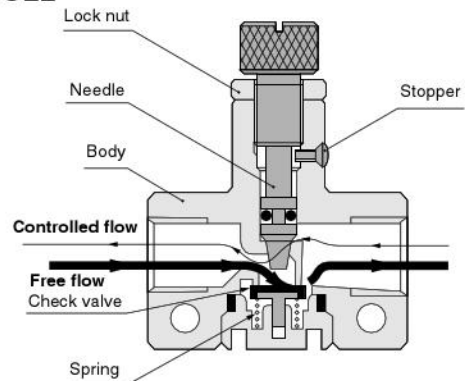

### ● KSC21 ● KSC31 ● KSC41

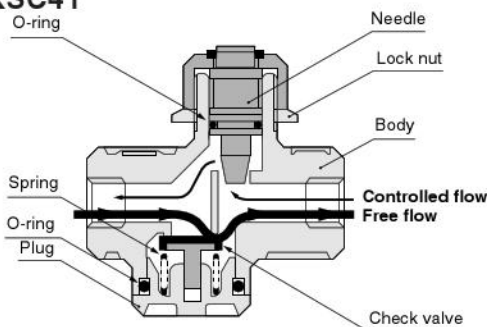

### ● KSC6 ● KSC8

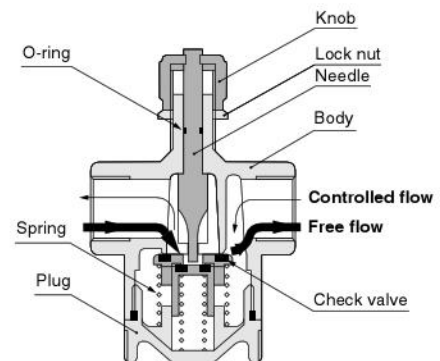

Note: In **KSC6** and **KSC8**, turning the knob clockwise increases the controlled flow rate, while turning the knob counterclockwise reduces it.  
(For all other models, this is reversed.)

# Dimensions (mm)

## ● KSC11

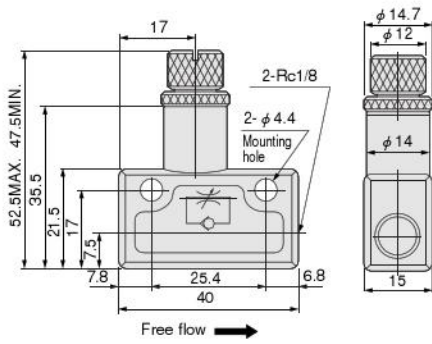

## ● KSC22

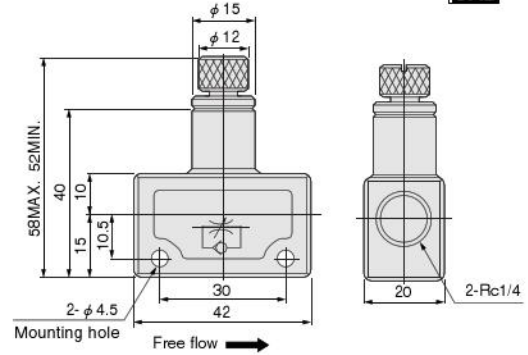

## ● KSC21 ● KSC31 ● KSC41

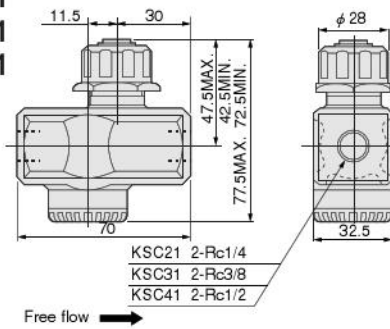

## ● KSC6 ● KSC8

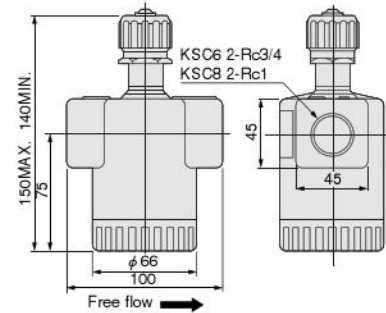

# Flow Rate Characteristics

## ● KSC11

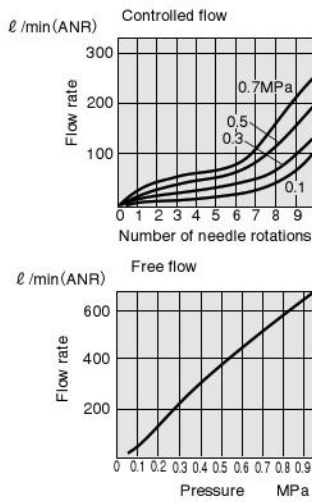

## ● KSC22

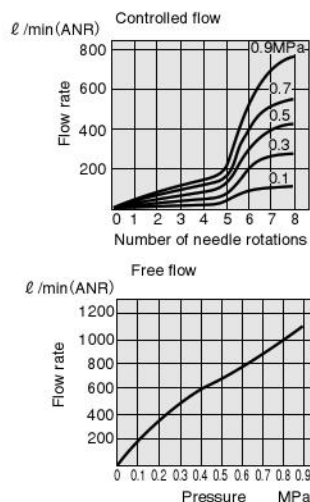

## ● KSC21

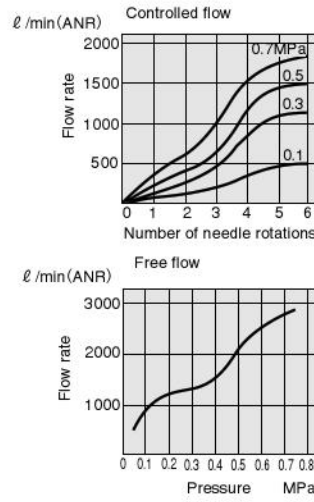

## ● KSC31

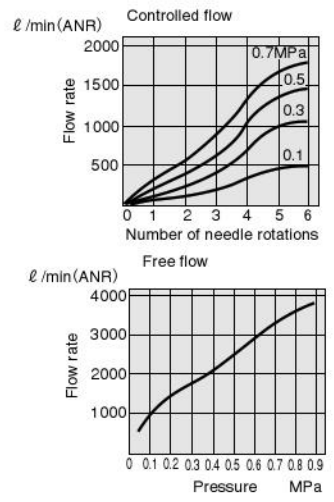

## ● KSC41

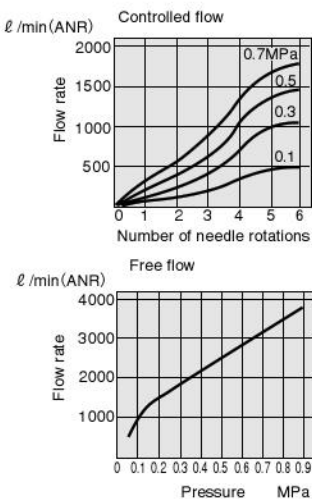

## ● KSC6

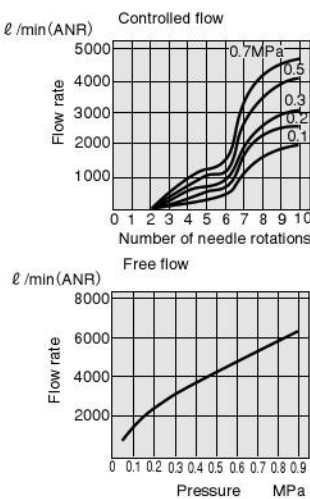

## ● KSC8

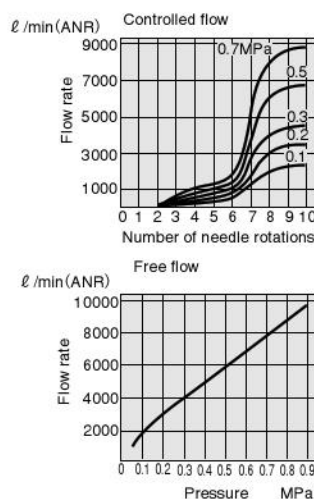

1MPa = 145psi.  
1 l/min = 0.0353ft<sup>3</sup>/min.