

# Robot Joint

## IAI Robot Compatible

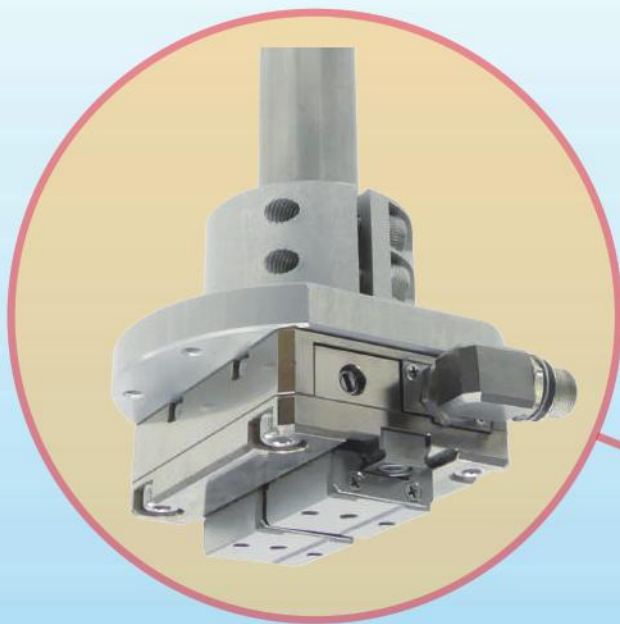

- Light weight and compact
- New designing is not required
- Quickly connect 5 types of actuators

- Flat type air hand
- 3 finger hand
- Electric hand
- Compliance light
- Auto hand changer



# Robot Joint

## IAI SCARA Robot Compatible

- Specialized robot joints are available for mounting 5 series of Koganei actuators to IAI SCARA robots and vertical articulated robots.
- Man-hours can be greatly reduced from equipment setup by mounting robot joints to IAI robots.

### ● SCARA robot from IAI

**IAI**



### ● Electric hand mounting example



### ● Flat type air hand mounting example



### ● 3 finger hand mounting example



### <SCARA robot system example>

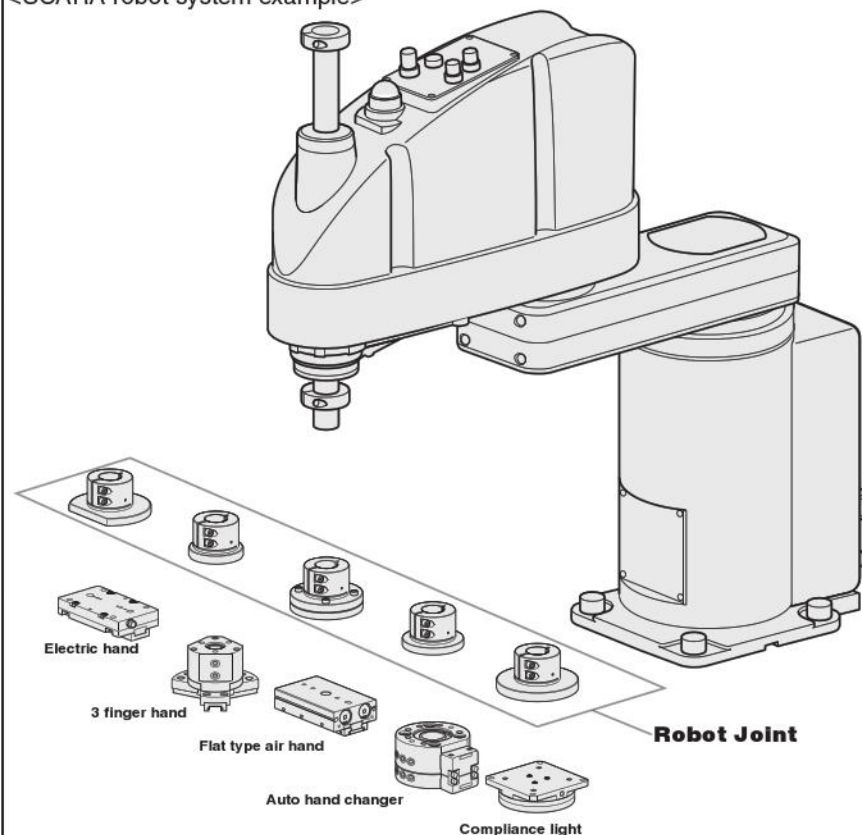

● Robot Joint models

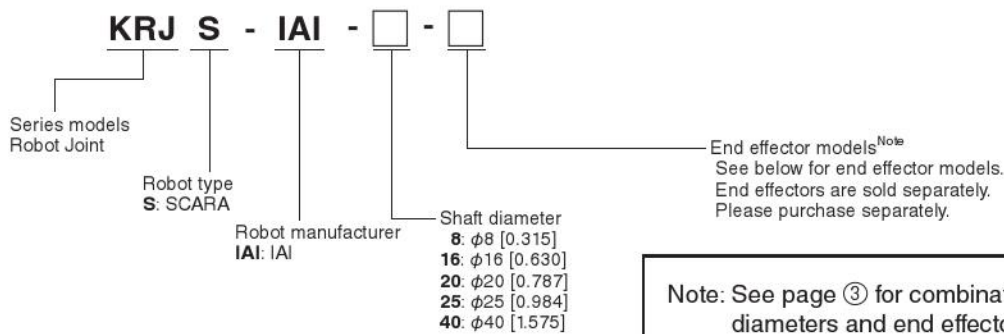

● Compatibility table for shaft diameters and IAI robot models

Shaft diameter (mm [in.])	Robot models
<b>8 [0.315]</b>	IX-NNN1205
	IX-NNN1505
	IX-NNN1805
	IXA-3(4)NNN1805
	IXP-3(4)N3515(3510)
	IXP-3(4)N4515(4510)
<b>16 [0.630]</b>	IX-NNN2515H
	IX-NNN3515H
	IX-NSN5016H
	IX-NSN6016H
	IX-TNN(UNN)3015H
	IX-TNN(UNN)3515H

Shaft diameter (mm [in.])	Robot model
<b>20 [0.787]</b>	IX-NNN5020H(5030H)
	IX-NNN6020H(6030H)
	IX-HNN(INN)5020H
	IX-HNN(INN)6020H
	IXA-3(4)NNN3015
	IXA-3(4)NNN4518(4533)
	IXA-3(4)NNN6018(6033)
	IXA-3(4)NSN3015
	IXA-3(4)NSN4518(4533)
	IXA-3(4)NSN6018(6033)
<b>25 [0.984]</b>	IX-NNN7020H(7040H)
	IX-NNN8020H(8040H)
	IX-HNN(INN)7020H(7040H) IX-HNN(INN)8020H(8040H)
<b>40 [1.575]</b>	IX-NNN10040
	IX-NNN12040

● End effector models

Flat type air hand	3 finger hand	Electric hand		Compliance light	Auto hand changer
					
AFDPG6	NHE1D16	EWHA6H	EW2H8	CPL34F	MJC3
AFDPG8	NHE1D20	EWHA12H	EW2H18	CPL54F	MJC10
AFDPG12	NHE1D25	EWHA24H	EW2H28	CPL70F	MJC20
AFDPG14		EWHA36H	EW2HL8	CPL90F	MJC60
AFDPG18		EWHA12A	EW2HL18		
AFDPG25		EWHA24A	EW2HL28		
AFDPGL6		EWHA36A			
AFDPGL8					
AFDPGL12					
AFDPGL14					
AFDPGL18					
AFDPGL25					

Note: The above end effectors (5 series) are sold separately. Please purchase separately.

Combination of shaft diameter and end effector model

SCARA robots

● Air hand (flat type air hand and 3 finger hand) combinations

Shaft diameter	Flat type air hand												3 finger hand		
	AFDPG6	AFDPG8	AFDPG12	AFDPG14	AFDPG18	AFDPG25	AFDPGL6	AFDPGL8	AFDPGL12	AFDPGL14	AFDPGL18	AFDPGL25	NHE1D16	NHE1D20	NHE1D25
8 [0.315]	○	○	-	-	-	-	○	○	-	-	-	-	-	-	-
16 [0.630]	○	○	○	-	-	-	○	○	○	-	-	-	○	○	-
20 [0.787]	-	○	○	○	-	-	-	○	○	○	-	-	-	○	○
25 [0.984]	-	-	○	○	○	-	-	-	○	○	○	-	-	-	○
40 [1.575]	-	-	-	-	○	○	-	-	-	-	○	○	-	-	-

● Compliance light combinations

Shaft diameter	Compliance light			
	CPL34F	CPL54F	CPL70F	CPL90F
8 [0.315]	○	-	-	-
16 [0.630]	○	○	-	-
20 [0.787]	-	○	○	-
25 [0.984]	-	-	○	○
40 [1.575]	-	-	-	-

● Auto hand changer combinations

Shaft diameter	Auto hand changer			
	MJC3	MJC10	MJC20	MJC60
8 [0.315]	○	-	-	-
16 [0.630]	○	○	-	-
20 [0.787]	-	○	-	-
25 [0.984]	-	○	○	-
40 [1.575]	-	-	-	○

● Electric hand combinations

Shaft diameter	Electric hand												
	EWHA6H	EWHA12H	EWHA24H	EWHA36H	EWHA12A	EWHA24A	EWHA36A	EW2H8	EW2H18	EW2H28	EW2HL8	EW2HL18	EW2HL28
8 [0.315]	○	-	-	-	-	-	-	○	-	-	○	-	-
16 [0.630]	○	○	-	-	○	○	○	○	○	-	○	○	-
20 [0.787]	-	○	○	○	○	○	○	-	○	○	-	○	○
25 [0.984]	-	○	○	○	○	○	○	-	○	○	-	○	○
40 [1.575]	-	-	○	○	-	○	○	-	-	○	-	-	○



Installation procedure

1. SCARA robot (model: KRJS-□)

- ① Install the end effector and adapter plate.  
If not included, the adapter plate is not required.
- ② Install the adapter plate (or end effector if the model does not include an adapter plate) and robot joint.
- ③ Insert the robot joint into the shaft, until the end.
- ④ We recommend the following procedure if the D-cut in the shaft is used for positioning.  
The screw used in the tapped hole for positioning must be prepared by the customer.  
[Recommended procedure when using tapped hole for positioning]  
 (1) Temporarily screw in the positioning screw, and then decide the position of the robot joint.  
 (2) Temporarily tighten the shaft clamp bolt to secure the robot joint.  
 (3) Remove the temporarily tightened positioning screw.
- ⑤ Tighten the shaft clamp bolt.
- ⑥ If the model has 2 shaft clamp bolts, alternately tighten them 3 times or more by the specified tightening torque.

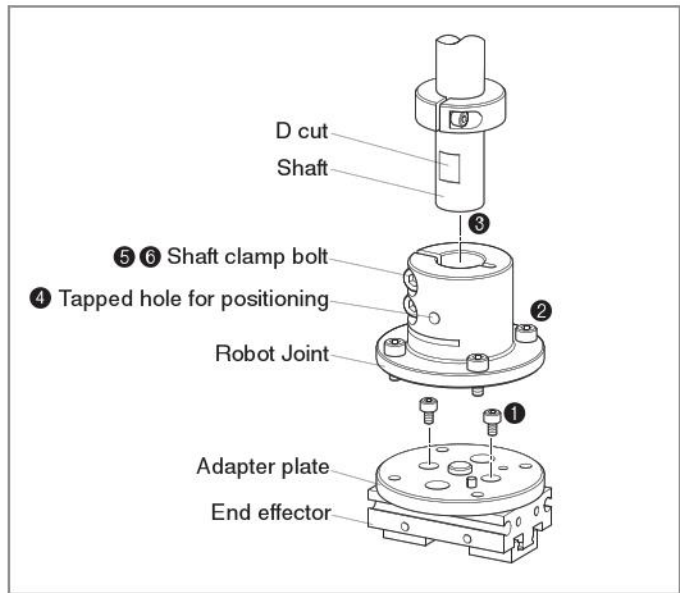

Caution

If you cannot insert the shaft because the shaft hole in the robot joint is too narrow, then put a plate (a washer or flathead screwdriver can also be used) into the slit, then tighten a bolt (a fastening screw is also possible) into the threaded hole, so the shaft hole widens and the shaft can be inserted. After insertion is complete, remove the bolt and plate.

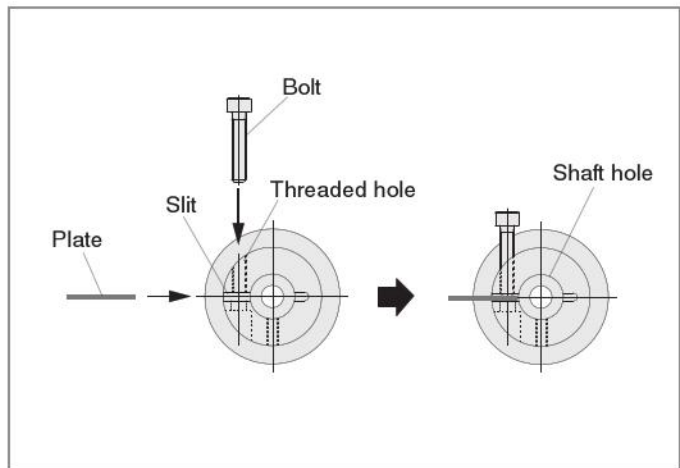

## Handling instructions and precautions

### Retaining force

#### ● Robot Joint for SCARA robots

Shaft diameter (mm [in.])	Holding force F (N)	Holding torque T (N·m [in·lbf])
<b>8 [0.315]</b>	400 [89.920]	1.4 [12.391]
<b>16 [0.630]</b>	1400 [314.7]	14 [123.9]
<b>20 [0.787]</b>	1500 [337.2]	15 [132.8]
<b>25 [0.984]</b>	1600 [359.7]	23 [203.6]
<b>40 [1.575]</b>	5000 [1124]	90 [796.6]

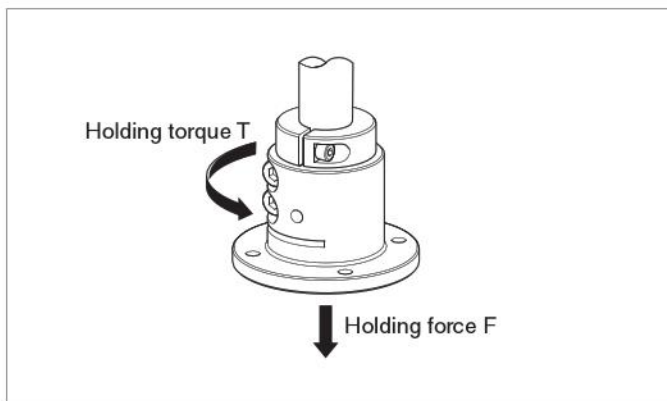

### Material

Name of part	Material
Robot Joint	Aluminum alloy (alumite treatment)
Adapter plate	Aluminum alloy (alumite treatment)
Bolt	Stainless steel
Parallel pin	Stainless steel

### Tightening torque

Screw size	Tightening torque (N·m [in·lbf])
M2.5	0.36 [3.186]
M3	0.63 [5.576]
M4	1.5 [13.277]
M5	3 [26.553]
M6	5.2 [46.025]
M8	12.5 [110.6]

#### Caution

If there is a risk of bolts loosening due to shocks or vibrations, consider taking measures to prevent them from loosening.

**Shaft diameter: 8 [0.315]**

**Configuration ①**

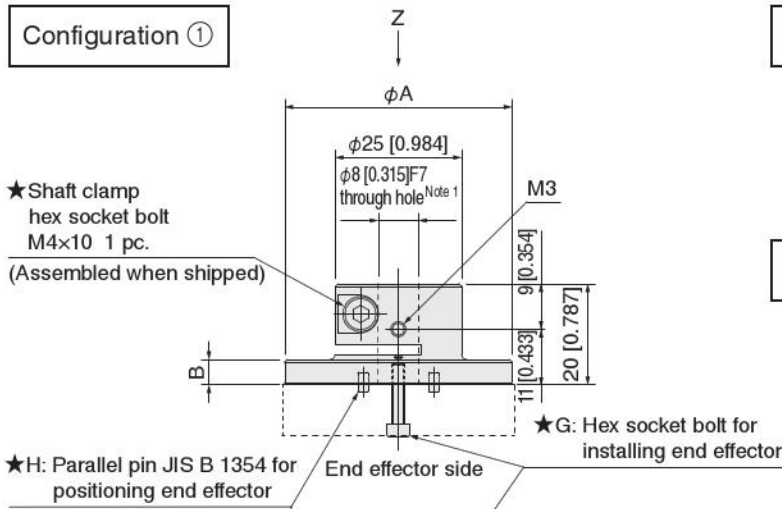

**Shape I**

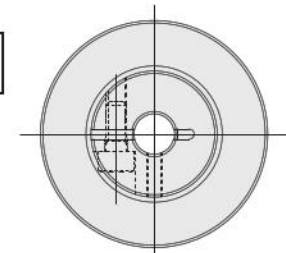

**Shape II**

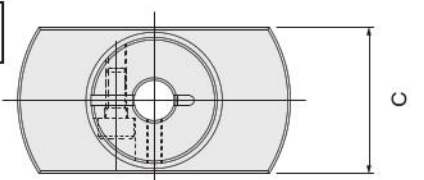

**Configuration ②**

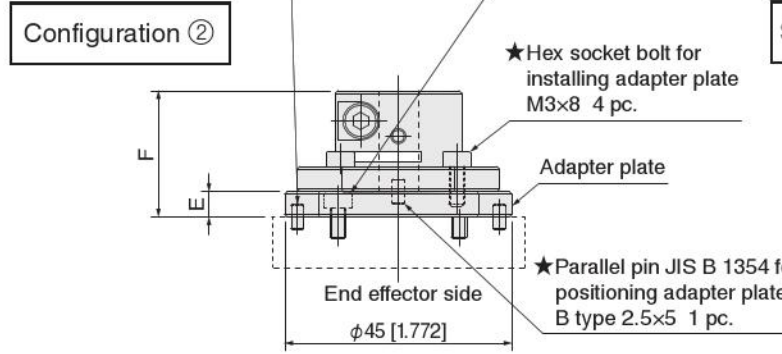

**Shape III**

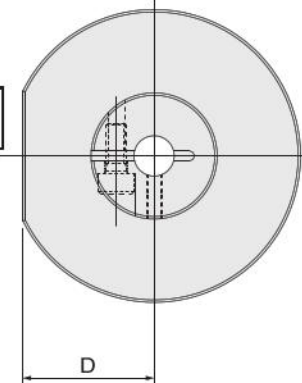

View from arrow Z

**Shaft diameter: 8 [0.315]**

## ● Air hand

Model	Mass (g [oz])		Configuration	Shape	Dimensions						Accessories			
	Product <sup>Note 3</sup>	End effector <sup>Note 4</sup>			A	B	C	D	E	F	G		H	
											Size	Count	Size	Count
<b>KRJS-IAI-8-AFDPG6</b>	30 [1.06]	52 [1.83]	①	I	29 [1.142]	5 [0.197]	-	-	-	-	M2.5×12	2	B type 2×4	2
<b>KRJS-IAI-8-AFDPG8</b>	70 [2.47]	86 [3.03]	②	II	40 [1.575]	5 [0.197]	32 [1.260]	-	5 [0.197]	25 [0.984]	M3×6	2	B type 2.5×5	2
<b>KRJS-IAI-8-AFDPGL6</b>	45 [1.59]	60 [2.12]	①	II	54 [2.126]	5 [0.197]	29 [1.142]	-	-	-	M2.5×12	2	B type 2×4	2
<b>KRJS-IAI-8-AFDPGL8</b>	60 [2.12]	135 [4.76]	①	II	78 [3.071]	5 [0.197]	32 [1.260]	-	-	-	M3×14	2	B type 2.5×5	2

## ● Compliance light

Model	Mass (g [oz])		Configuration	Shape	Dimensions						Accessories			
	Product <sup>Note 3</sup>	End effector <sup>Note 4</sup>			A	B	C	D	E	F	G		H	
											Size	Count	Size	Count
<b>KRJS-IAI-8-CPL34F</b>	50 [1.76]	42 [1.48]	①	I	46 [1.811]	5 [0.197]	-	-	-	-	M3×8	4	B type 3×6	1

## ● Auto hand changer

Model	Mass (g [oz])		Configuration	Shape	Dimensions						Accessories			
	Product <sup>Note 3</sup>	End effector <sup>Note 4</sup>			A	B	C	D	E	F	G		H	
											Size	Count	Size	Count
<b>KRJS-IAI-8-MJC3</b>	35 [1.23]	65 [2.29]	①	I	34 [1.339]	5 [0.197]	-	-	-	-	M3×20	4	B type 2×5	1

## ● Electric hand

Model	Mass (g [oz])		Configuration	Shape	Dimensions						Accessories			
	Product <sup>Note 3</sup>	End effector <sup>Note 4</sup>			A	B	C	D	E	F	G		H	
											Size	Count	Size	Count
<b>KRJS-IAI-8-EWHA6H</b>	60 [2.12]	150 [5.29]	①	III	58 [2.283]	5 [0.197]	-	26 [1.024]	-	-	M3×10	4	B type 2×6	2
<b>KRJS-IAI-8-EW2H8</b>	60 [2.12]	90 [3.17]	①	III	58 [2.283]	5 [0.197]	-	26 [1.024]	-	-	M3×16	4	B type 2×6	2
<b>KRJS-IAI-8-EW2HL8</b>	60 [2.12]	140 [4.94]	①	III	58 [2.283]	5 [0.197]	-	26 [1.024]	-	-	M3×16	4	B type 2×6	2

Note 1: The F7 tolerance is before machining of the slit. After machining of the slit, F7 may be inaccurate.

2: In the drawings, the (★) bolts and pins are accessories.

3: The product weight includes the weight of the bolts and parallel pins that are accessories.

4: The end effectors are not included with these products. They must be ordered separately.

**Shaft diameter: 16 [0.630]**

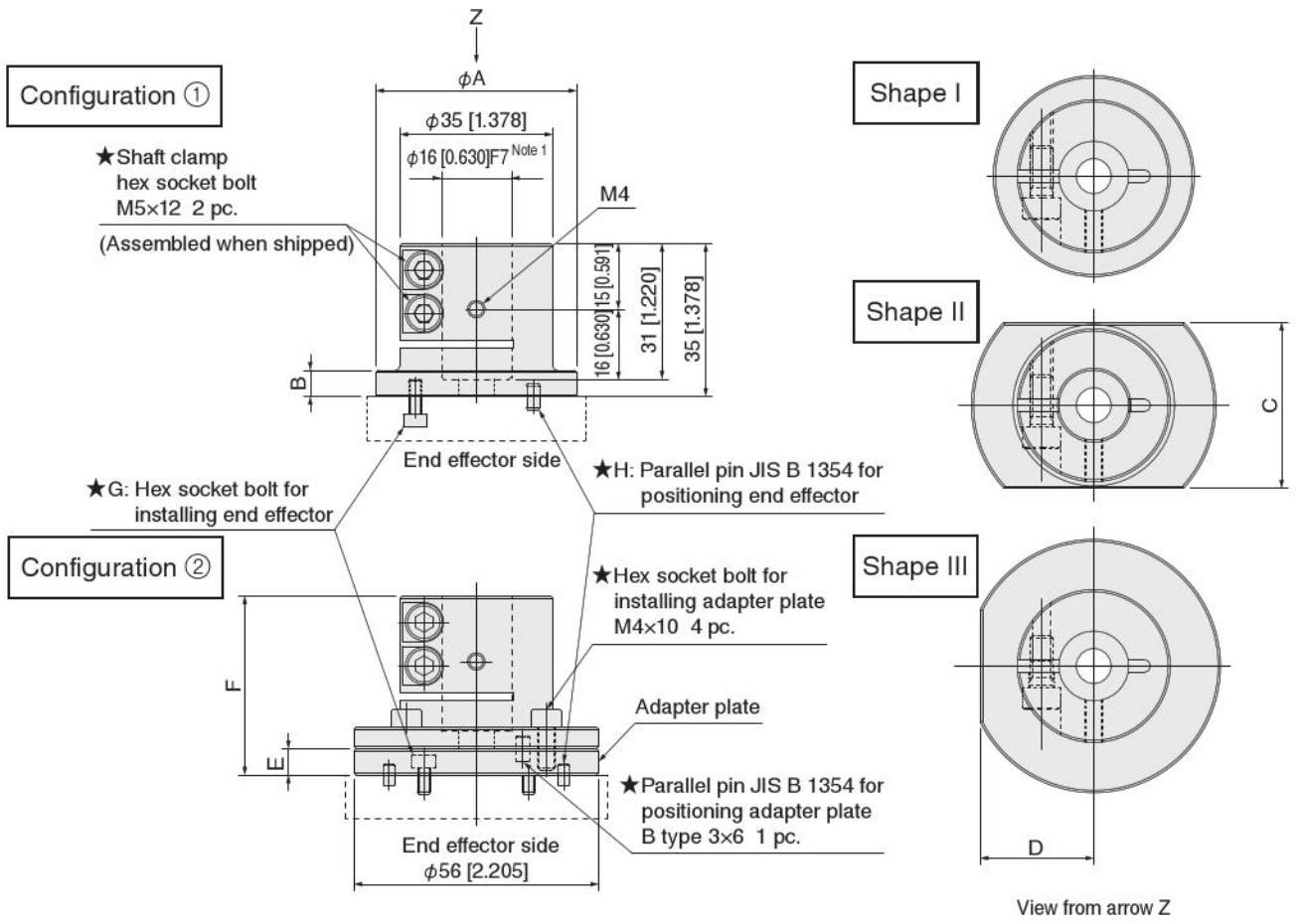

## Shaft diameter: 16 [0.630]

### ● Air hand

Model	Mass (g [oz])		Configuration	Shape	Dimensions						Accessories			
	Product <sup>Note 3</sup>	End effector <sup>Note 4</sup>			A	B	C	D	E	F	G		H	
											Size	Count	Size	Count
KRJS-IAI-16-AFDPG6	85 [3.00]	52 [1.83]	①	I	35 [1.378]	-	-	-	-	-	M2.5×12	2	B type 2×4	2
KRJS-IAI-16-AFDPG8	160 [5.64]	86 [3.03]	②	I	56 [2.205]	5 [0.197]	-	-	6 [0.236]	41 [1.614]	M3×6	2	B type 2.5×5	2
KRJS-IAI-16-AFDPG12	160 [5.64]	200 [7.05]	②	I	56 [2.205]	5 [0.197]	-	-	6 [0.236]	41 [1.614]	M4×8	2	B type 3×6	2
KRJS-IAI-16-AFDPGL6	110 [3.88]	60 [2.12]	①	II	56 [2.205]	6 [0.236]	38 [1.496]	-	-	-	M2.5×12	2	B type 2×4	2
KRJS-IAI-16-AFDPGL8	125 [4.41]	135 [4.76]	①	II	78 [3.071]	6 [0.236]	38 [1.496]	-	-	-	M3×14	2	B type 2.5×5	2
KRJS-IAI-16-AFDPGL12	155 [5.47]	330 [11.64]	①	II	96 [3.780]	8 [0.315]	41 [1.614]	-	-	-	M4×18	2	B type 3×6	2
KRJS-IAI-16-NHE1D16	100 [3.53]	170 [6.00]	①	I	41 [1.614]	10 [0.394]	-	-	-	-	M3×35	3	B type 2×4	1
KRJS-IAI-16-NHE1D20	115 [4.06]	306 [10.79]	①	I	48 [1.890]	10 [0.394]	-	-	-	-	M3×40	3	B type 3×6	1

### ● Compliance light

Model	Mass (g [oz])		Configuration	Shape	Dimensions						Accessories			
	Product <sup>Note 3</sup>	End effector <sup>Note 4</sup>			A	B	C	D	E	F	G		H	
											Size	Count	Size	Count
KRJS-IAI-16-CPL34F	100 [3.53]	42 [1.48]	①	I	46 [1.811]	6 [0.236]	-	-	-	-	M3×8	4	B type 3×6	1
KRJS-IAI-16-CPL54F	115 [4.06]	130 [4.59]	①	I	54 [2.126]	6 [0.236]	-	-	-	-	M5×12	4	A type 4×6 <sup>Note 5</sup>	1

### ● Auto hand changer

Model	Mass (g [oz])		Configuration	Shape	Dimensions						Accessories			
	Product <sup>Note 3</sup>	End effector <sup>Note 4</sup>			A	B	C	D	E	F	G		H	
											Size	Count	Size	Count
KRJS-IAI-16-MJC3	85 [3.00]	65 [2.29]	①	I	35 [1.378]	-	-	-	-	-	M3×20	4	B type 2×5	1
KRJS-IAI-16-MJC10	125 [4.41]	235 [8.29]	①	I	54 [2.126]	9 [0.354]	-	-	-	-	M5×30	4	B type 4×8	1

### ● Electric hand

Model	Mass (g [oz])		Configuration	Shape	Dimensions						Accessories			
	Product <sup>Note 3</sup>	End effector <sup>Note 4</sup>			A	B	C	D	E	F	G		H	
											Size	Count	Size	Count
KRJS-IAI-16-EWHA6H	115 [4.06]	150 [5.29]	①	III	58 [2.283]	6 [0.236]	-	26 [1.024]	-	-	M3×10	4	B type 2×6	2
KRJS-IAI-16-EWHA12H	160 [5.64]	290 [10.23]	①	I	80 [3.150]	6 [0.236]	-	-	-	-	M3×16	4	B type 2×6	2
KRJS-IAI-16-EWHA12A	115 [4.06]	170 [6.00]	①	III	58 [2.283]	6 [0.236]	-	26 [1.024]	-	-	M3×12	4	B type 2×6	2
KRJS-IAI-16-EWHA24A	140 [4.94]	260 [9.17]	①	III	72 [2.835]	6 [0.236]	-	31 [1.220]	-	-	M3×12	4	B type 2×6	2
KRJS-IAI-16-EWHA36A	140 [4.94]	260 [9.17]	①	III	72 [2.835]	6 [0.236]	-	31 [1.220]	-	-	M3×12	4	B type 2×6	2
KRJS-IAI-16-EW2H8	115 [4.06]	90 [3.17]	①	III	58 [2.283]	6 [0.236]	-	26 [1.024]	-	-	M3×16	4	B type 2×6	2
KRJS-IAI-16-EW2H18	140 [4.94]	160 [5.64]	①	III	72 [2.835]	6 [0.236]	-	31 [1.220]	-	-	M4×18	4	B type 3×6	2
KRJS-IAI-16-EW2HL8	115 [4.06]	140 [4.94]	①	III	58 [2.283]	6 [0.236]	-	26 [1.024]	-	-	M3×16	4	B type 2×6	2
KRJS-IAI-16-EW2HL18	140 [4.94]	250 [8.82]	①	III	72 [2.835]	6 [0.236]	-	31 [1.220]	-	-	M4×18	4	B type 3×6	2

Note 1: The F7 tolerance is before machining of the slit. After machining of the slit, F7 may be inaccurate.

2: In the drawings, the (★) bolts and pins are accessories.

3: The product weight includes the weight of the bolts and parallel pins that are accessories.

4: The end effectors are not included with these products. They must be ordered separately.

5: The KRJS-IAI-16-CPL54F uses the old JIS A type parallel pin for positioning the end effector.

**Shaft diameter: 20 [0.787]**

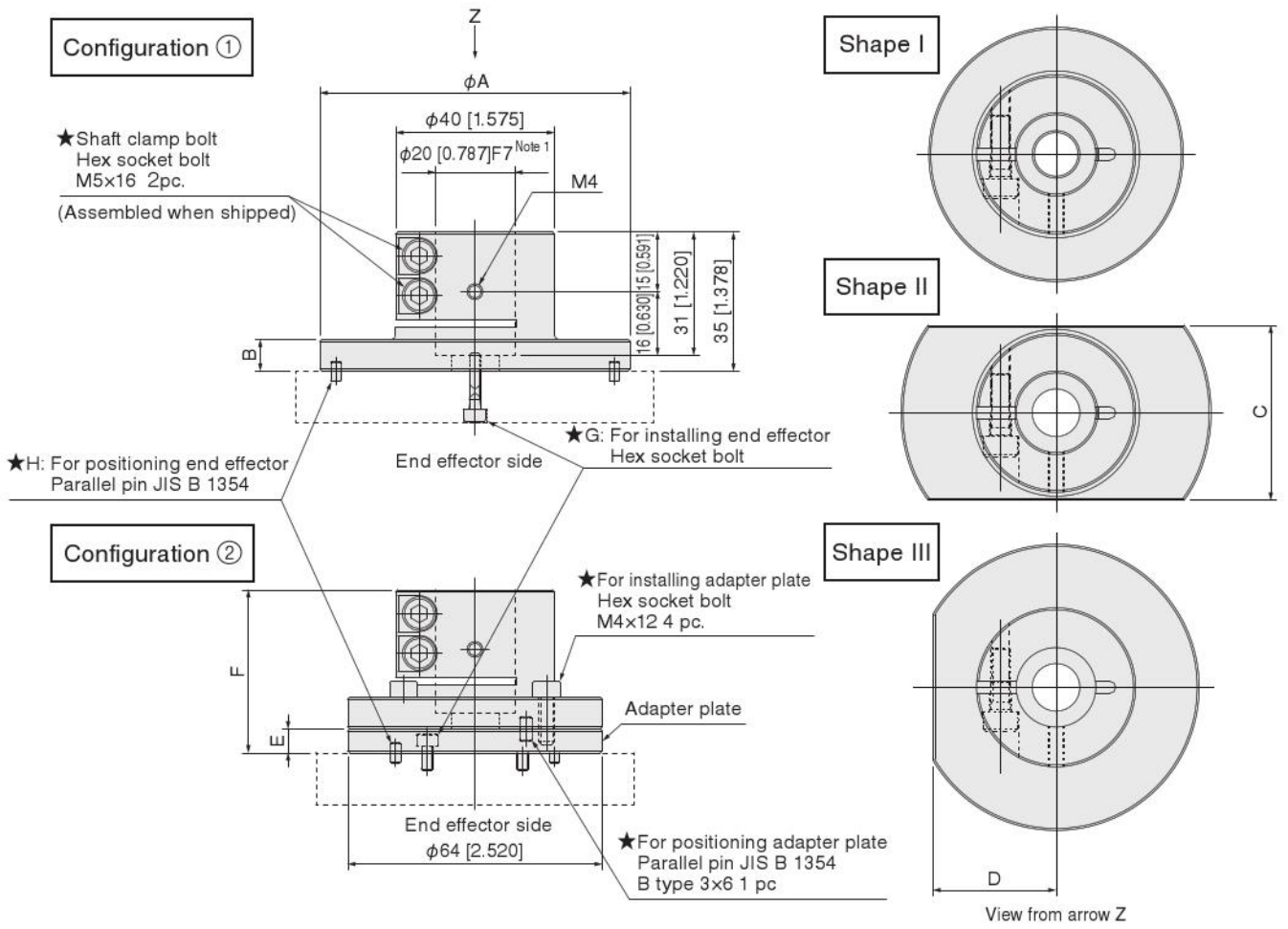

**Shaft diameter: 20 [0.787]**

● Air hand

Model	Mass (g [oz])		Configuration	Shape	Dimensions						Accessories			
	Product <sup>Note 3</sup>	End effector <sup>Note 4</sup>			A	B	C	D	E	F	G		H	
											Size	Count	Size	Count
KRJS-IAI-20-AFDPG8	220 [7.76]	86 [3.03]	②	I	64 [2.520]	8 [0.315]	-	-	6 [0.236]	41 [1.614]	M3x6	2	B type 2.5x5	2
KRJS-IAI-20-AFDPG12	220 [7.76]	200 [7.05]	②	I	64 [2.520]	8 [0.315]	-	-	6 [0.236]	41 [1.614]	M4x8	2	B type 3x6	2
KRJS-IAI-20-AFDPG14	235 [8.29]	390 [13.76]	②	I	64 [2.520]	8 [0.315]	-	-	8 [0.315]	43 [1.693]	M5x10	2	B type 3x6	2
KRJS-IAI-20-AFDPGL8	155 [5.47]	135 [4.76]	①	II	78 [3.071]	8 [0.315]	44 [1.732]	-	-	-	M3x14	2	B type 2.5x5	2
KRJS-IAI-20-AFDPGL12	175 [6.17]	330 [11.64]	①	II	96 [3.780]	8 [0.315]	44 [1.732]	-	-	-	M4x18	2	B type 3x6	2
KRJS-IAI-20-AFDPGL14	155 [5.47]	570 [20.11]	①	II	90 [3.543]	8 [0.315]	44 [1.732]	-	-	-	M5x14	2	B type 3x6	2
KRJS-IAI-20-NHE1D20	125 [4.41]	306 [10.79]	①	I	48 [1.890]	10 [0.394]	-	-	-	-	M3x40	3	B type 3x6	1
KRJS-IAI-20-NHE1D25	155 [5.47]	580 [20.46]	①	I	60 [2.362]	10 [0.394]	-	-	-	-	M4x45	3	B type 3x6	1

● Compliance light

Model	Mass (g [oz])		Configuration	Shape	Dimensions						Accessories			
	Product <sup>Note 3</sup>	End effector <sup>Note 4</sup>			A	B	C	D	E	F	G		H	
											Size	Count	Size	Count
KRJS-IAI-20-CPL54F	175 [6.17]	130 [4.59]	①	I	72 [2.835]	8 [0.315]	-	-	-	-	M5x10	4	B type 4x8	1
KRJS-IAI-20-CPL70F	175 [6.17]	250 [8.82]	①	I	70 [2.756]	8 [0.315]	-	-	-	-	M5x14	4	B type 5x8	1

● Auto hand changer

Model	Mass (g [oz])		Configuration	Shape	Dimensions						Accessories			
	Product <sup>Note 3</sup>	End effector <sup>Note 4</sup>			A	B	C	D	E	F	G		H	
											Size	Count	Size	Count
KRJS-IAI-20-MJC10	135 [4.76]	235 [8.29]	①	I	54 [2.126]	9 [0.354]	-	-	-	-	M5x30	4	B type 4x8	1

● Electric hand

Model	Mass (g [oz])		Configuration	Shape	Dimensions						Accessories			
	Product <sup>Note 3</sup>	End effector <sup>Note 4</sup>			A	B	C	D	E	F	G		H	
											Size	Count	Size	Count
KRJS-IAI-20-EWHA12H	200 [7.05]	290 [10.23]	①	I	80 [3.150]	8 [0.315]	-	-	-	-	M3x16	4	B type 2x6	2
KRJS-IAI-20-EWHA24H	200 [7.05]	350 [12.35]	①	I	80 [3.150]	8 [0.315]	-	-	-	-	M3x16	4	B type 2x6	2
KRJS-IAI-20-EWHA36H	200 [7.05]	360 [12.70]	①	I	80 [3.150]	8 [0.315]	-	-	-	-	M3x16	4	B type 2x6	2
KRJS-IAI-20-EWHA12A	140 [4.94]	170 [6.00]	①	I	58 [2.283]	8 [0.315]	-	-	-	-	M3x12	4	B type 2x6	2
KRJS-IAI-20-EWHA24A	175 [6.17]	260 [9.17]	①	III	72 [2.835]	8 [0.315]	-	31 [1.220]	-	-	M3x12	4	B type 2x6	2
KRJS-IAI-20-EWHA36A	175 [6.17]	260 [9.17]	①	III	72 [2.835]	8 [0.315]	-	31 [1.220]	-	-	M3x12	4	B type 2x6	2
KRJS-IAI-20-EW2H18	175 [6.17]	160 [5.64]	①	III	72 [2.835]	8 [0.315]	-	31 [1.220]	-	-	M4x18	4	B type 3x6	2
KRJS-IAI-20-EW2H28	225 [7.94]	360 [12.70]	①	III	88 [3.465]	8 [0.315]	-	40 [1.575]	-	-	M4x25	4	B type 3x6	2
KRJS-IAI-20-EW2HL18	175 [6.17]	250 [8.82]	①	III	72 [2.835]	8 [0.315]	-	31 [1.220]	-	-	M4x18	4	B type 3x6	2
KRJS-IAI-20-EW2HL28	225 [7.94]	480 [16.93]	①	III	88 [3.465]	8 [0.315]	-	40 [1.575]	-	-	M4x25	4	B type 3x6	2

Note 1: The F7 tolerance is before machining of the slit. After machining of the slit, F7 may be inaccurate.  
 2: In the drawings, the (★) bolts and pins are accessories.  
 3: The product weight includes the weight of the bolts and parallel pins that are accessories.  
 4: The end effectors are not included with these products. They must be ordered separately.

**Shaft diameter: 25 [0.984]**

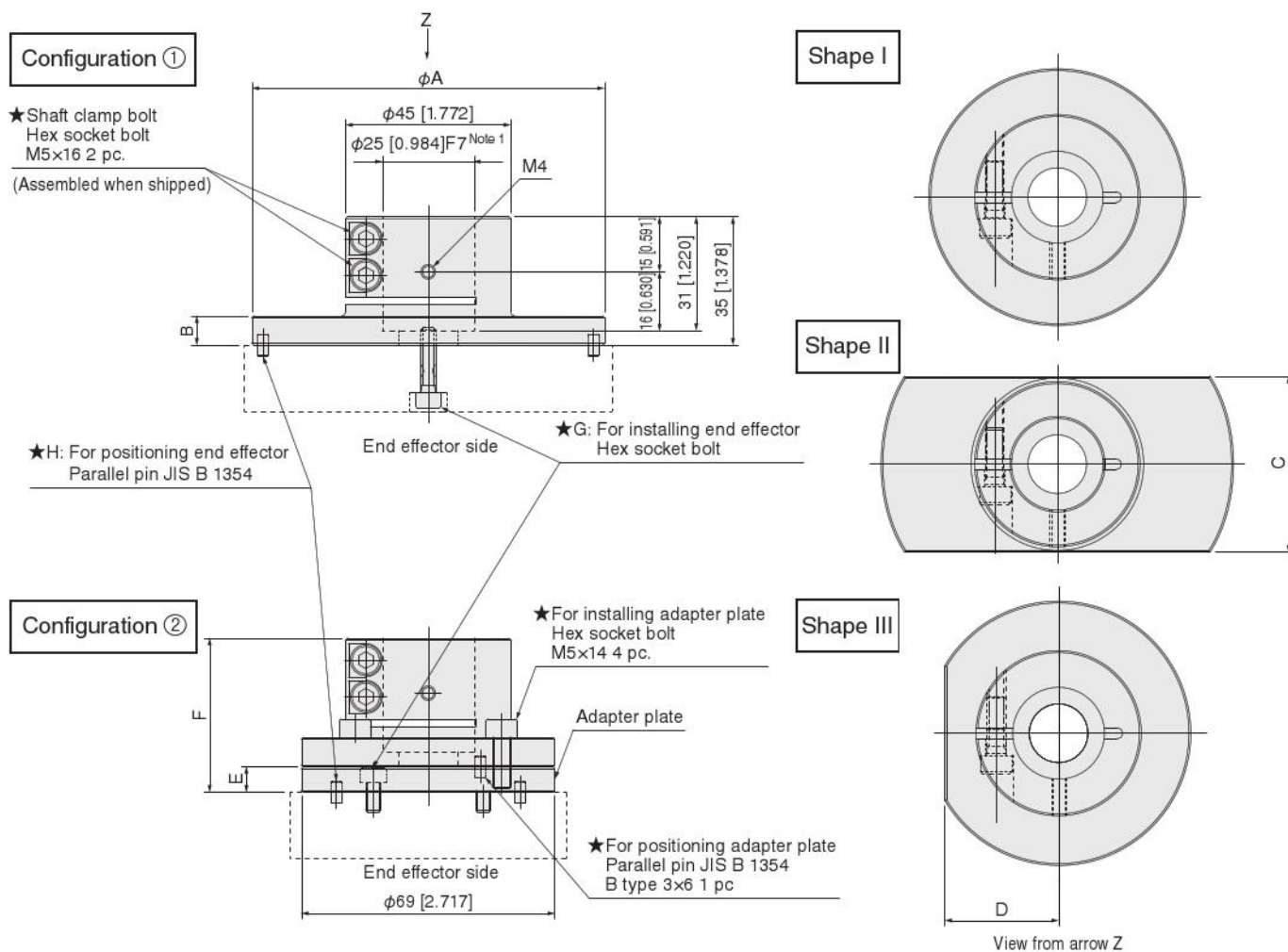

**Shaft diameter: 25 [0.984]**

## ● Air hand

Model	Mass (g [oz])		Configuration	Shape	Dimensions						Accessories			
	Product <sup>Note 3</sup>	End effector <sup>Note 4</sup>			A	B	C	D	E	F	G		H	
											Size	Count	Size	Count
KRJS-IAI-25-AFDPG12	265 [9.35]	200 [7.05]	②	I	69 [2.717]	8 [0.315]	-	-	7 [0.276]	42 [1.654]	M4x8	2	B type 3x6	2
KRJS-IAI-25-AFDPG14	275 [9.70]	390 [13.76]	②	I	69 [2.717]	8 [0.315]	-	-	8 [0.315]	43 [1.693]	M5x10	2	B type 3x6	2
KRJS-IAI-25-AFDPG18	275 [9.70]	690 [24.34]	②	I	69 [2.717]	8 [0.315]	-	-	8 [0.315]	43 [1.693]	M5x10	2	B type 3x6	2
KRJS-IAI-25-AFDPGL12	195 [6.88]	330 [11.64]	①	II	96 [3.780]	8 [0.315]	48 [1.890]	-	-	-	M4x18	2	B type 3x6	2
KRJS-IAI-25-AFDPGL14	195 [6.88]	570 [20.11]	①	II	90 [3.543]	8 [0.315]	52 [2.047]	-	-	-	M5x14	2	B type 3x6	2
KRJS-IAI-25-AFDPGL18	195 [6.88]	1020 [35.98]	①	II	90 [3.543]	8 [0.315]	52 [2.047]	-	-	-	M5x16	2	B type 3x6	2
KRJS-IAI-25-NHE1D25	165 [5.82]	580 [20.46]	①	I	60 [2.362]	10 [0.394]	-	-	-	-	M4x45	3	B type 3x6	1

## ● Compliance light

Model	Mass (g [oz])		Configuration	Shape	Dimensions						Accessories			
	Product <sup>Note 3</sup>	End effector <sup>Note 4</sup>			A	B	C	D	E	F	G		H	
											Size	Count	Size	Count
KRJS-IAI-25-CPL70F	185 [6.53]	250 [8.82]	①	I	70 [2.756]	8 [0.315]	-	-	-	-	M5x14	4	B type 5x8	1
KRJS-IAI-25-CPL90F	255 [8.99]	460 [16.23]	①	I	90 [3.543]	8 [0.315]	-	-	-	-	M6x16	4	B type 6x8	1

## ● Auto hand changer

Model	Mass (g [oz])		Configuration	Shape	Dimensions						Accessories			
	Product <sup>Note 3</sup>	End effector <sup>Note 4</sup>			A	B	C	D	E	F	G		H	
											Size	Count	Size	Count
KRJS-IAI-25-MJC10	145 [5.11]	235 [8.29]	①	I	54 [2.126]	9 [0.354]	-	-	-	-	M5x30	4	B type 4x8	1
KRJS-IAI-25-MJC20	190 [6.70]	470 [16.58]	①	I	70 [2.756]	9 [0.354]	-	-	-	-	M5x35	4	B type 5x8	1

## ● Electric hand

Model	Mass (g [oz])		Configuration	Shape	Dimensions						Accessories			
	Product <sup>Note 3</sup>	End effector <sup>Note 4</sup>			A	B	C	D	E	F	G		H	
											Size	Count	Size	Count
KRJS-IAI-25-EWHA12H	210 [7.41]	290 [10.23]	①	I	80 [3.150]	8 [0.315]	-	-	-	-	M3x16	4	B type 2x6	2
KRJS-IAI-25-EWHA24H	210 [7.41]	350 [12.35]	①	I	80 [3.150]	8 [0.315]	-	-	-	-	M3x16	4	B type 2x6	2
KRJS-IAI-25-EWHA36H	210 [7.41]	360 [12.70]	①	I	80 [3.150]	8 [0.315]	-	-	-	-	M3x16	4	B type 2x6	2
KRJS-IAI-25-EWHA12A	150 [5.29]	170 [6.00]	①	I	58 [2.283]	8 [0.315]	-	-	-	-	M3x12	4	B type 2x6	2
KRJS-IAI-25-EWHA24A	185 [6.53]	260 [9.17]	①	III	72 [2.835]	8 [0.315]	-	31 [1.220]	-	-	M3x12	4	B type 2x6	2
KRJS-IAI-25-EWHA36A	185 [6.53]	260 [9.17]	①	III	72 [2.835]	8 [0.315]	-	31 [1.220]	-	-	M3x12	4	B type 2x6	2
KRJS-IAI-25-EW2H18	185 [6.53]	160 [5.64]	①	III	72 [2.835]	8 [0.315]	-	31 [1.220]	-	-	M4x18	4	B type 3x6	2
KRJS-IAI-25-EW2H28	235 [8.29]	360 [12.70]	①	III	88 [3.465]	8 [0.315]	-	40 [1.575]	-	-	M4x25	4	B type 3x6	2
KRJS-IAI-25-EW2HL18	185 [6.53]	250 [8.82]	①	III	72 [2.835]	8 [0.315]	-	31 [1.220]	-	-	M4x18	4	B type 3x6	2
KRJS-IAI-25-EW2HL28	235 [8.29]	480 [16.93]	①	III	88 [3.465]	8 [0.315]	-	40 [1.575]	-	-	M4x25	4	B type 3x6	2

Note 1: The F7 tolerance is before machining of the slit. After machining of the slit, F7 may be inaccurate.

2: In the drawings, the (★) bolts and pins are accessories.

3: The product weight includes the weight of the bolts and parallel pins that are accessories.

4: The end effectors are not included with these products. They must be ordered separately.

**Shaft diameter: 40 [1.575]**

**Configuration ①**

★Hex socket bolt for shaft clamp  
M8×30 2 pc.  
(Assembled when shipped)

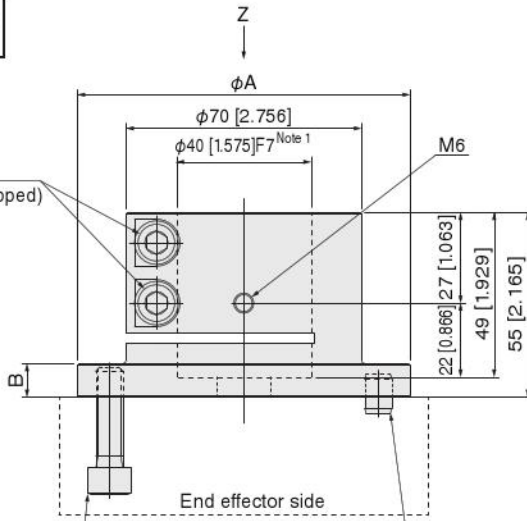

★G: Hex socket bolt for installing end effector

★H: Parallel pin JIS B 1354 for positioning end effector

**Configuration ②**

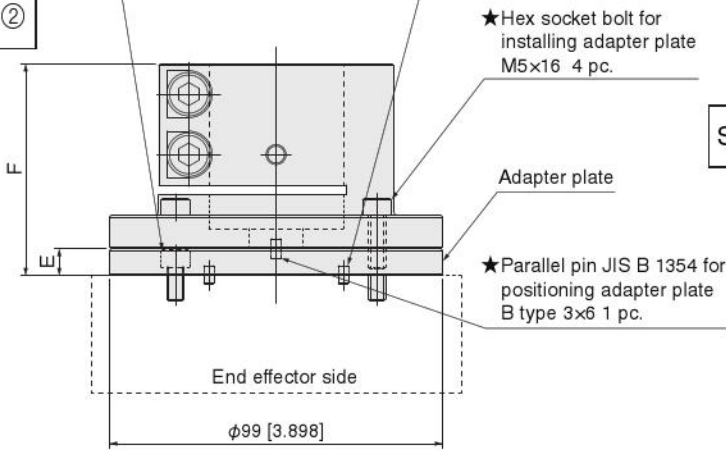

★Hex socket bolt for installing adapter plate  
M5×16 4 pc.

★Parallel pin JIS B 1354 for positioning adapter plate  
B type 3×6 1 pc.

**Shape I**

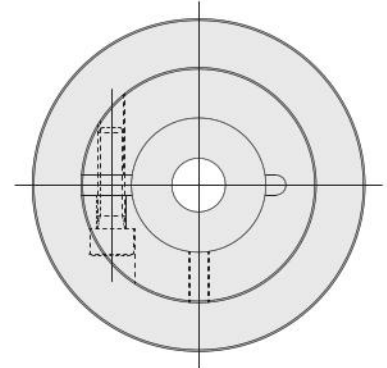

**Shape II**

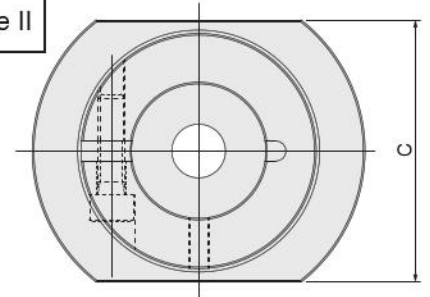

**Shape III**

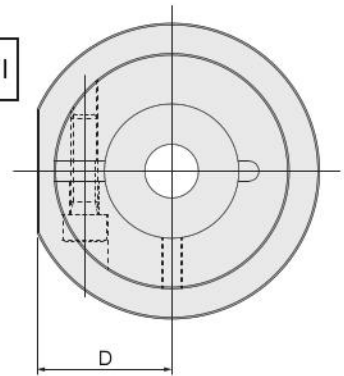

View from arrow Z

**Shaft diameter: 40 [1.575]**

## ● Air hand

Model	Mass (g [oz])		Configuration	Shape	Dimensions						Accessories			
	Product <small>Note 3</small>	End effector <small>Note 4</small>			A	B	C	D	E	F	G		H	
											Size	Count	Size	Count
<b>KRJS-IAI-40-AFDPG18</b>	770 [27.16]	690 [24.34]	②	I	99 [3.898]	10 [0.394]	-	-	8 [0.315]	63 [2.480]	M5×10	2	B type 3×6	2
<b>KRJS-IAI-40-AFDPG25</b>	640 [22.57]	1520 [53.62]	①	II	130 [5.118]	10 [0.394]	78 [3.071]	-	-	-	M8×16	2	B type 5×8	2
<b>KRJS-IAI-40-AFDPGL18</b>	770 [27.16]	1020 [35.98]	②	I	99 [3.898]	10 [0.394]	-	-	8 [0.315]	63 [2.480]	M5×10	2	B type 3×6	2
<b>KRJS-IAI-40-AFDPGL25</b>	840 [29.63]	2320 [81.83]	①	II	210 [8.268]	10 [0.394]	78 [3.071]	-	-	-	M8×16	2	B type 5×8	2

## ● Auto hand changer

Model	Mass (g [oz])		Configuration	Shape	Dimensions						Accessories			
	Product <small>Note 3</small>	End effector <small>Note 4</small>			A	B	C	D	E	F	G		H	
											Size	Count	Size	Count
<b>KRJS-IAI-40-MJC60</b>	570 [20.11]	1600 [56.44]	①	I	99 [3.898]	10 [0.394]	-	-	-	-	M8×30	4	B type 8×12	1

## ● Electric hand

Model	Mass (g [oz])		Configuration	Shape	Dimensions						Accessories			
	Product <small>Note 3</small>	End effector <small>Note 4</small>			A	B	C	D	E	F	G		H	
											Size	Count	Size	Count
<b>KRJS-IAI-40-EWHA24H</b>	495 [17.46]	350 [12.35]	①	I	80 [3.150]	10 [0.394]	-	-	-	-	M3×16	4	B type 2×6	2
<b>KRJS-IAI-40-EWHA36H</b>	495 [17.46]	360 [12.70]	①	I	80 [3.150]	10 [0.394]	-	-	-	-	M3×16	4	B type 2×6	2
<b>KRJS-IAI-40-EWHA24A</b>	460 [16.23]	260 [9.17]	①	I	70 [2.756]	-	-	-	-	-	M3×12	4	B type 2×6	2
<b>KRJS-IAI-40-EWHA36A</b>	460 [16.23]	260 [9.17]	①	I	70 [2.756]	-	-	-	-	-	M3×12	4	B type 2×6	2
<b>KRJS-IAI-40-EW2H28</b>	525 [18.52]	360 [12.70]	①	III	88 [3.465]	10 [0.394]	-	40 [1.575]	-	-	M4×25	4	B type 3×6	2
<b>KRJS-IAI-40-EW2HL28</b>	525 [18.52]	480 [16.93]	①	III	88 [3.465]	10 [0.394]	-	40 [1.575]	-	-	M4×25	4	B type 3×6	2

Note 1: The F7 tolerance is before machining of the slit. After machining of the slit, F7 may be inaccurate.

2: In the drawings, the (★) bolts and pins are accessories.

3: The product weight includes the weight of the bolts and parallel pins that are accessories.

4: The end effectors are not included with these products. They must be ordered separately.

MEMO

A series of horizontal dashed lines for writing.



# Limited Warranty

KOGANEI CORP. warrants its products to be free from defects in material and workmanship subject to the following provisions.

**Warranty Period** The warranty period is 180 days from the date of delivery.

**Koganei Responsibility** If a defect in material or workmanship is found during the warranty period, KOGANEI CORP. will replace any part proved defective under normal use free of charge and will provide the service necessary to replace such a part.

**Limitations**

- This warranty is in lieu of all other warranties, expressed or implied, and is limited to the original cost of the product and shall not include any transportation fee, the cost of installation or any liability for direct, indirect or consequential damage or delay resulting from the defects.

- KOGANEI CORP. shall in no way be liable or responsible for injuries or damage to persons or property arising out of the use or operation of the manufacturer's product.

- This warranty shall be void if the engineered safety devices are removed, made inoperative or not periodically checked for proper functioning.

- Any operation beyond the rated capacity, any improper use or application, or any improper installation of the product, or any substitution upon it with parts not furnished or approved by KOGANEI CORP., shall void this warranty.

- This warranty covers only such items supplied by KOGANEI CORP. The products of other manufacturers are covered only by such warranties made by those original manufacturers, even though such items may have been included as the components.

The specifications are subject to change without notice.

URL <http://www.koganei.co.jp>

E-mail: [overseas@koganei.co.jp](mailto:overseas@koganei.co.jp)



## KOGANEI CORPORATION

### OVERSEAS DEPARTMENT

3-11-28, Midori-cho, Koganei City, Tokyo 184-8533, Japan  
Tel: 81-42-383-7271 Fax: 81-42-383-7276

### KOGANEI INTERNATIONAL AMERICA, INC.

48860 Millmont Drive, suite 108C, Fremont, California 94538  
Tel: 1-510-744-1626 Fax: 1-510-744-1676

### SHANGHAI KOGANEI INTERNATIONAL TRADING CORPORATION

Room 2606-2607, Tongda Venture Building No.1, Lane 600, Tianshan Road,  
Shanghai, 200051, China  
Tel: 86-21-6145-7313 Fax: 86-21-6145-7323

### TAIWAN KOGANEI TRADING CO., LTD.

Rm. 2, 13F, No88, Sec. 2, Zhongxiao E. Rd., Zhongzheng Dist., Taipei City 100,  
Taiwan (ROC)  
Tel: 886-2-2393-2717 Fax: 886-2-2393-2719

### KOGANEI KOREA CO., LTD.

6F-601, Tower Bldg., 1005, Yeongdeong-dong, Giheung-gu, Yongin-si, Gyeonggi-do,  
446-908, Korea  
Tel: 82-31-246-0414 Fax: 82-31-246-0415

### KOGANEI (THAILAND) CO., LTD.

555 Rasa Tower 1, 12th Floor, Unit 1202 and 1207, Phaholyothin Road,  
Chatuchak, Chatuchak, Bangkok 10900 Thailand  
Tel: 66-2-937-4250 Fax: 66-2-937-4254

### KOGANEI AUTOMATION (MALAYSIA) SDN.BHD.

Suite 29-2, Level 29, Menara 1MK, No.1, Jalan Kiara, Mont Kiara  
50480, Kuala Lumpur, Malaysia  
Tel: 60-12-537-7086

### KOGANEI ASIA PTE. LTD.

69 Ubi Road 1, #05-18 Oxley Bizhub, Singapore 408731  
Tel: 65-6293-4512 Fax: 65-6293-4513