

<http://www.koganei.co.jp>



# High-speed valve K2·K3·K4 K Series



**New!**  
**K3/K4 series**

**Full model change!**  
**K2 Series** 2-port valves  
For high-speed sorting and air blow applications

**High-speed response**  
0.4 to 3.0 ms (ON)  
**Low power**  
9 W and higher specifications come with power saving circuit.  
24 W → 1.5 W, 9 W → 1 W

**New!**  
**3-, 4-port valves K3/K4 Series**  
For high-speed suction pickup, air blow, and high-speed cylinder operation applications



**High-speed response**  
1.2 to 4.0 ms (ON)  
**Low power**  
24 W specifications come with power saving circuit.  
24 W → 2 W



# High-speed 2-port valve **K2 Series**

## Full model change!

**NEW**  
Plug connector



Now attachable/detachable plug connector available.

**Compact configuration**  
10 mm wide

**High-speed response**  
0.4 to 3.0 ms (ON)

**IP67 equivalent**

IP67 equivalent protection structure enables use in a wide range of environments.

**Low power**

9 W and higher specifications come with power saving circuit.  
24 W → **1.5 W**  
9 W → **1 W**

**High flow rate**

Sonic conductance C  
0.2 to **0.6** [dm<sup>3</sup>/(s·bar)]  
Flow rate 55 to **160** l/min(ANR)  
(at 0.4 MPa)

**NEW**

**Surge protection** Note

Surge absorption circuit eliminates OFF delay for high-speed response.

Note: Excluding -N circuit specification



Black coil case and body.

**Non-oil specification**

3 types of direct piping specifications



**NEW** Base piping type

Selecting base piping -25 (sub-base) enables high flow rates.

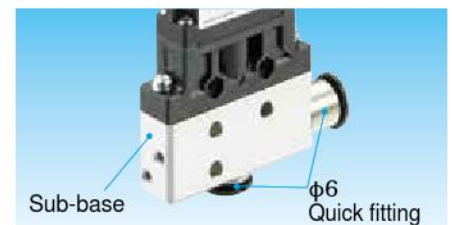

\* Manifold can also be produced under special specifications.

**NEW** Four additional power specification types! Supports a wide range of electrical control.

**No protection circuit type**  
Circuit specifications -N

- No surge absorbing circuit

**Surge absorbing type**  
Circuit specifications -Z

- Surge absorbing circuit

**Power saving type**  
Circuit specifications -L

- Power saving circuit  
24 W → 1.5 W  
9 W → 1 W
- Surge absorbing circuit

**PLC drive type**  
Circuit specifications -R

- PLC drive circuit
- Power saving circuit (9 W or higher)  
24 W → 1.5 W  
9 W → 1 W
- Surge absorbing circuit

**Pulsed blow type**  
Circuit specifications -X

- Built-in microprocessor
- Pulse oscillation circuit
- Remote control setting configuration
- Surge absorbing circuit



**CAUTION** Before using this valve, be sure to read the "Safety Precautions" on page 5.

## Application examples

### High-speed sorting, material handling applications (Supports high cycle time.)

- Chip component manufacturing, taping machines, parts feeders, packaging machines, color sorting machines, etc.

Work sorting applications

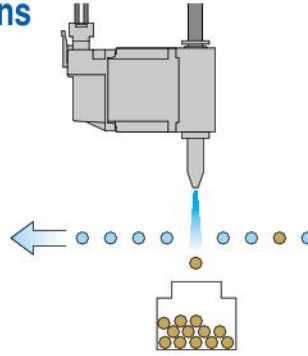

### Intermittent blowing applications (Saving energy, reducing air consumption volume)

- Air blowing process in assembly, component cleaning process, machining process, cooling process, molding removal, ionizers, etc.

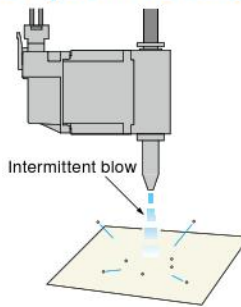

- When pulsed blow type for intermittent blowing applications is used

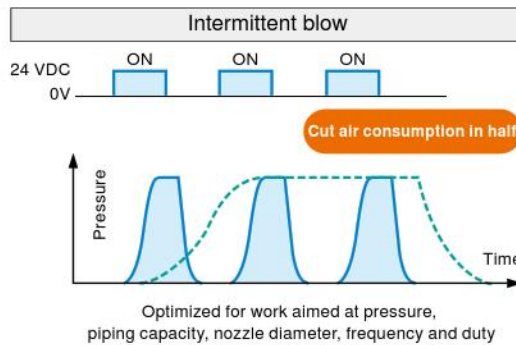
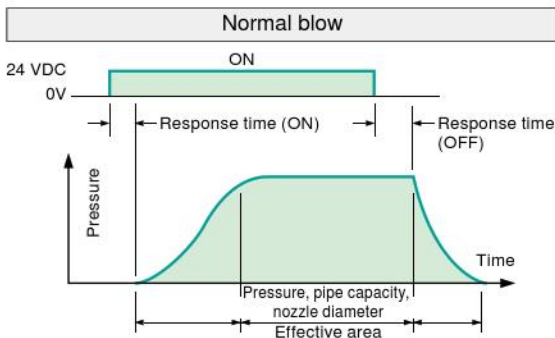
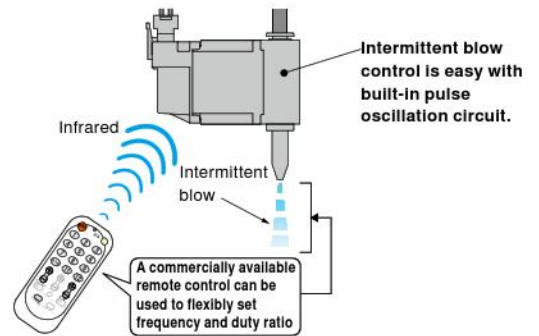

## Variations

- A total of 20 type variations are available to provide a choice of response time (ON) and flow rate, and direct piping or base piping.
- A selection for four power specification types: 2 W, 4 W, 9 W (with power saving circuit), and 24 W (with power saving circuit)

Response time (at ON) and flow rate

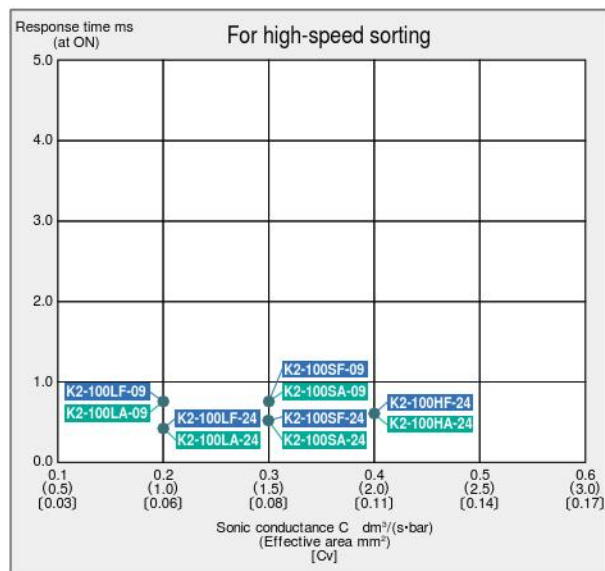
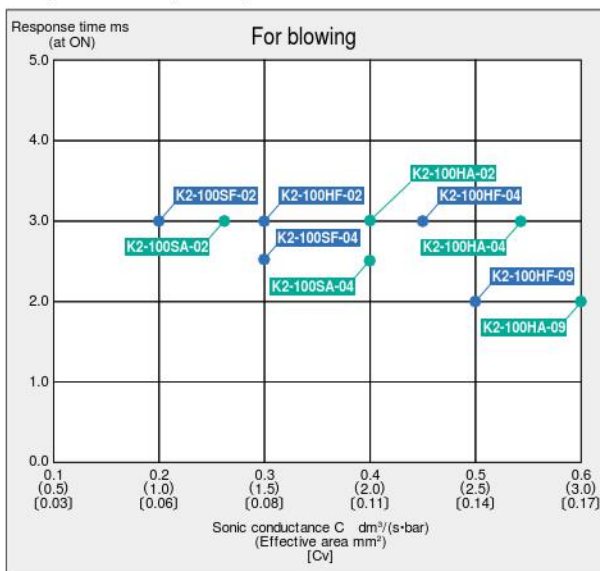

New release!

# High-speed 3- or 4-port valve **K3·K4 Series**

**Low-power type achieves world's fastest response!**

- Meets the need for a 3-port valve in high-speed sorting applications.
- Perfect for high-speed suction pickup (K3).
- Compact, high-speed response direct operated 3- or 4-port valve (compared to Koganei products)

## High-speed response

1.2 to 4.0 ms (at ON)

## Low power

24 W specification comes with power saving circuit.  
24 W → 2 W

## Surge protection

Note

Surge absorption circuit eliminates OFF delay for high-speed response.

Note: Excluding -N circuit specification.

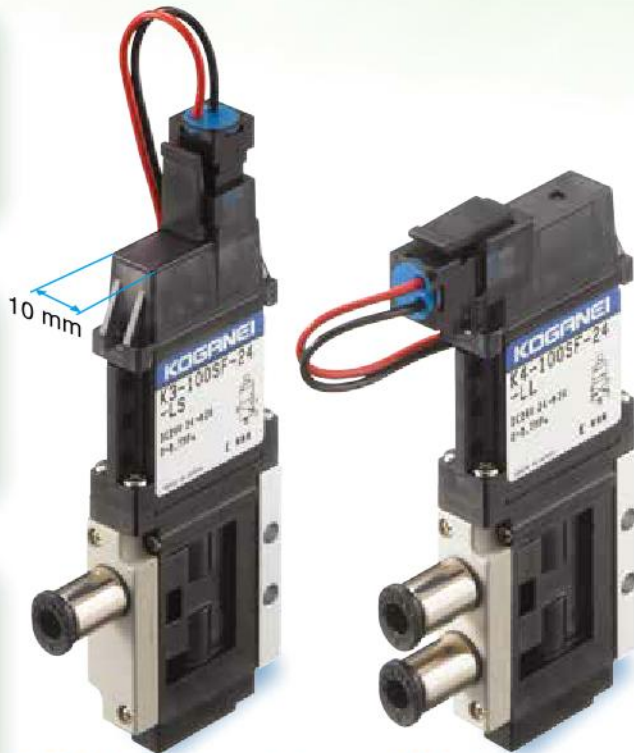

K3 Series (3-port valve)

K4 Series (4-port valve)

## Compact/10 mm wide

## IP67 equivalent

IP67 equivalent protection structure enables use in a wide range of environments.

## Non-oil specification

## Vacuum specifications (K3)

Support for both vacuum and positive pressure

## Piping variations (Photographs show K3 Series.)

Base piping	Direct piping			
	With air supply block	No air supply block	Output port	
			Fitting block	Female thread block

## Supports a wide range of electrical control.

### No protection circuit type

Circuit specifications -N

- No surge absorbing circuit

### Surge absorbing type

Circuit specifications -Z

- Surge absorbing circuit

### Power saving type

Circuit specifications -L

- Power saving circuit 24 W → 2 W
- Surge absorbing circuit

### PLC drive type

Circuit specifications -R

- PLC drive circuit
- Power saving circuit 24 W → 2 W
- Surge absorbing circuit

### Pulsed blow type

Circuit specifications -X

- Built-in microprocessor
- Pulse oscillation circuit
- Remote control setting configuration
- Surge absorbing circuit

\* For internal circuit, see page 20.



**CAUTION** Before using this valve, be sure to read the "Safety Precautions" on page 5.

## Application examples

### High-speed sorting applications (Supports high cycle time.)

- Chip component manufacturing, taping machines, parts feeders, packaging machines, color sorting machines, etc.

Work sorting applications

**An exhaust port ensures OFF air cutoff when secondary side piping is long.**

### High-speed suction pickup applications

- Sheet feeding, small electronic component production, etc.

**Perfect for improving productivity through high-speed response.**

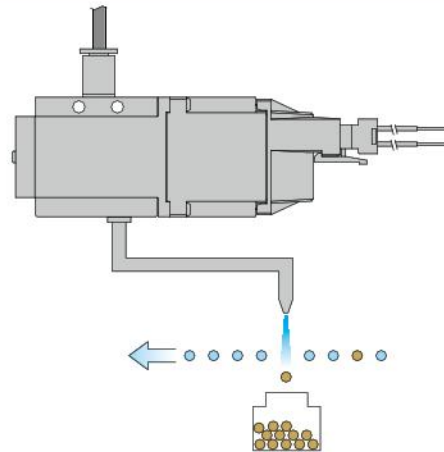

Deenergizing

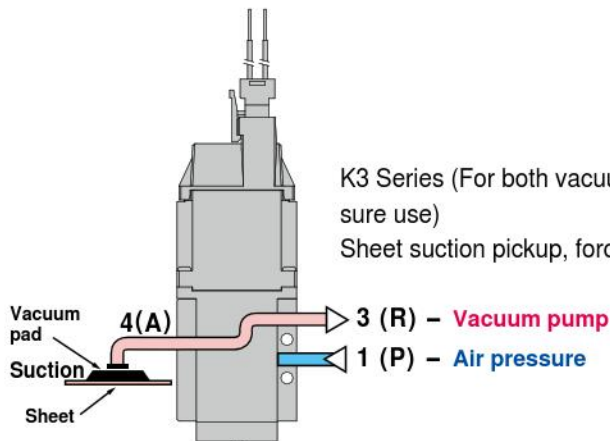

Energizing

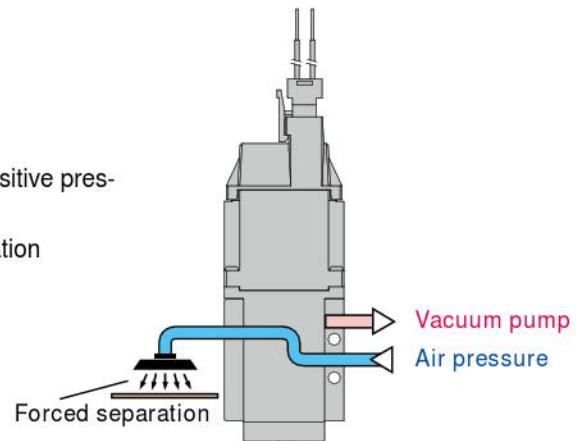

## Valve function and piping port position

### K3 Series

#### K3 (for positive pressure use)

		Deenergizing	Energizing
3 ports	Normally closed (NC)	4(A) → 3(R) 1(P) →	← 3(R) 1(P) →
	Normally open (NO)	2(B) ← 3(R) 1(P) →	← 3(R) 1(P) →

Caution: Positive pressure cannot be applied to the 3(R) port.

#### K3 (for vacuum use)

		Deenergizing	Energizing
3 ports	Normally closed (NC)	4(A) ← 3(R) atmosphere 1(P) vacuum pump, etc.	← 3(R) 1(P) →
	Normally open (NO)	2(B) ← 3(R) atmosphere 1(P) vacuum pump, etc.	← 3(R) 1(P) →

Caution: Positive pressure cannot be applied to the 3(R) port.

#### K3 (for both vacuum and positive pressure use)

		Deenergizing	Energizing
3 ports	Normally closed (NC)	4(A) → 3(R) vacuum pump, etc. 1(P) positive pressure	← 3(R) 1(P) →
	Normally open (NO)	2(B) ← 3(R) vacuum pump, etc. 1(P) positive pressure	← 3(R) 1(P) →

Caution: Positive pressure cannot be applied to the 3(R) port.

### K4 Series

#### K4 (for positive pressure use)

		Deenergizing	Energizing
4 ports	4(A) → 3(R) 2(B) ← 1(P)	← 3(R) 1(P) →	← 3(R) 1(P) →

Caution: Positive pressure cannot be applied to the 3(R) port.





#### Ultra-low pressure and high-speed actuator control

The operating pressure range can be from 0 MPa, which makes this valve perfect for actuators (metal cylinders, low constant speed cylinders, etc.) that operate at ultra-low pressure.

High-speed response also allows use for specific cylinder control (unloading of workpieces, pusher for defect removal, etc.) required in high-speed operation.

Before selecting and using the products, please read all safety precautions carefully to ensure proper product use. The safety precautions described below are to help you use the product safely and correctly, and to prevent injury or damage to you, other people, and assets. Always adhere to the following safety regulations: ISO4414 (Pneumatic fluid power - General rules and safety requirements for systems and their components) and JIS B 8370 (General rules relating to pneumatic systems).

Items are ranked as follows according to degree of potential danger or damage: "DANGER", "WARNING", "CAUTION", and "ATTENTION".

 <b>DANGER</b>	Indicates situations that can be clearly predicted as dangerous. Failure to avoid the situation creates the risk of death or serious injury. It could also result in damage or destruction of assets.
 <b>WARNING</b>	Indicates situations that, while not immediately dangerous, could become dangerous. Failure to avoid the situation creates the risk of death or serious injury. It could also result in damage or destruction of assets.
 <b>CAUTION</b>	Indicates situations that, while not immediately dangerous, could become dangerous. Failure to avoid the situation creates the risk of minor or semi-serious injury. It could also result in damage or destruction of assets.
 <b>ATTENTION</b>	While there is little chance of injury, this content refers to points that should be observed for appropriate use of the product.

- This product was designed and manufactured for use in general industrial machinery.
- When selecting and handling equipment, the system designer or another person with sufficient knowledge and experience should always read the safety precautions, catalog, instruction manual and other literature before commencing operation. Improper handling is dangerous.
- After reading the catalog, instruction manual, etc., always keep them in a location where they are readily available for reference to users of this product.
- If transferring or lending the product to another person, always attach the catalog, instruction manual, etc., to the product where they are easily visible, to ensure that the new user can use the product safely and properly.
- The danger, warning and caution items listed under these safety precautions do not cover all possible contingencies. Read the catalog and instruction manual carefully, and always keep safety first.

 **DANGER**

- Do not use the product for the purposes listed below:
  1. Medical equipment related to maintenance or management of human lives or bodies.
  2. Machines or equipment designed for the purpose of moving or transporting people.
  3. Critical safety components in mechanical devices.
 This product has not been planned or designed for purposes that require high levels of safety. Using the product in any of the ways described above creates the risk of loss of human life.
- Do not use the product in locations with or near dangerous substances such as flammable or ignitable substances. This product is not explosion-proof. Doing so creates the risk of ignition and fire.
- When mounting the product and workpiece, always make sure they are firmly supported and secured in place. Falling, dropping, or abnormal operation of the product creates the risk of personal injury.
- People using a pacemaker or other similar medical devices should keep a distance of at least one meter away from the product. Getting too close to the product creates the risk of malfunction of a pacemaker due to the strong magnet built into the product.
- Never attempt to modify the product. Abnormal operation can lead to injury, etc.
- Never attempt inappropriate disassembly, assembly or repair of the product relating to basic construction, or to its performance or to functions. Doing so creates the risk of injury, electric shock, fire, etc.
- Do not splash water on the product. Spraying it with water, washing it, or using it under water could result in malfunction of the product leading to injury, electric shock, fire, etc.
- While the product is in operation, avoid touching it with your hands or otherwise approaching too close. Also, do not attempt to make any adjustments to internal or attached mechanisms, or to perform any type of adjustment (manual override, connecting or disconnecting cable connectors, adjusting pressure switches, disconnecting tubes or sealed plugs, etc.) while the product is in operation. Under such conditions, the actuator may move suddenly, creating the risk of personal injury.

 **WARNING**

- Because Koganei products are designed for use under a wide variety of conditions, decisions concerning conformance with a particular system should be made upon the careful evaluation by the person in charge of system design.

- Assurances concerning expected system performance and safety are the responsibility of the designer who decides system conformity. Be sure to use the latest catalogs and technical materials to study and evaluate specification details, to consider the possibility of machine breakdown, and to configure a system that ensures fail-safe safety and reliability.
- Do not use the product in excess of its specification ranges. Doing so creates the risk of product breakdown, loss of function, or damage. It could also drastically reduce operating life.
  - Before supplying air or electricity to the device and before starting operation, always conduct a safety check of the area of machine operation. Unintentional supply of air or electricity could possibly result in electric shock, or in injury caused by contact with moving parts.
  - Do not touch terminals, switches, or other parts, while power is turned on. Doing so creates the risk of electric shock and malfunction.
  - Do not allow the product to be thrown into fire. Doing so creates the risk of explosion and the release of toxic gases.
  - Do not sit on the product, place your foot on it, or place other objects on it. Doing so creates the risk of injury due to tripping or the product tipping over or dropping, resulting in product damage and abnormal, erratic, or runaway operation.
  - When conducting any kind of operation for the product, such as maintenance, piping connection and disconnection, inspection, repair, or replacement, always turn off the air supply completely and confirm that residual pressure inside the product or in piping connected to the product is zero before proceeding. In particular, be aware that residual air will still be in the air compressor or air storage tank. The actuator could abruptly move if residual air pressure remains inside the piping, causing injury.
  - Before performing any kind of wiring work, be sure to turn off power. Failure to do so creates the risk of electric shock.
  - Correctly apply the rated voltage to the solenoid. Applying the wrong voltage will make it impossible to obtain the specified function, and creates the risk of damage to and burnout of the product.
  - Do not allow lead wires and other cords to become damaged. Allowing a cord to become cut, bent excessively, pulled, rolled up, placed under heavy objects, or squeezed between two objects creates the risk of current leaks or defective continuity that can lead to fire, electric shock, or abnormal operation.
  - Do not connect or disconnect connectors while power is turned on. Also, never apply unnecessary force to connectors. Doing so creates the risk of personal injury, device damage, and electric shock due to abnormal machine operation.
  - Always check the catalog and other reference materials for correct product wiring and piping. Improper wiring and piping creates the risk of damage to and abnormal operation of the

actuator, etc.

- In initial operations after the equipment has been idle for 48 hours or more, or has been in storage, there is a possibility that contacting parts may have become stuck, resulting in equipment operation delays or in sudden movements. Before these initial operations, always run a test to check that operating performance is normal.
- When the device is not used for long periods (over 30 days), it is possible that the contacting parts may have become stuck leading to slow operation or sudden movements. Check for proper operation a minimum of once every 30 days.
- Do not locate the solenoid valve and the wiring that controls it near power lines running a large current, powerful magnetic fields, or where power surges occur. Doing so could cause erratic operation.
- Solenoid valves generate surge voltage and electromagnetic waves at the OFF operation, which can interfere with the operation of nearby equipment. Use a surge protected solenoid or implement appropriate surge and electromagnetic protection measures for the electrical circuitry.
- Do not use the product at the beach, in direct sunlight, near mercury vapor lamps, or near equipment that generates ozone. Ozone causes rubber components to deteriorate resulting in reduced performance, or a limitation or stop of functions.
- Do not use any type of medium that is not specifically stipulated in the specifications. Using a non-specified medium could lead to short term loss of function, sudden degradation of performance, and a reduced operating life.
- When a solenoid valve is installed within the control panel and when the energizing time is long, implement heat dissipation measures in order to keep the temperature around the solenoid within specifications. Also note that continuous energizing for long periods will result in heat generation by the coil which can lead to deterioration of solenoid valve performance and shortening of its service life, and can adversely affect nearby equipment. Contact Koganei if you need to continuously energize for long periods or if the energizing time in a day needs to be longer than the deenergizing time.
- After completing wiring work, check to make sure that all connections are correct before turning on power.
- Do not use the product in locations subject to direct sunlight (ultraviolet radiation), high temperatures or high humidity, dust, salt, or iron powder. Do not expose the product to fluids or an ambient atmosphere that contains organic solvents, phosphate-based hydraulic fluid, sulfur dioxide gas, chlorine gas, acids, etc. It could lead to early shutdown of some functions, a sudden degradation of performance, and a reduced operating life. For information about materials, see Materials of major parts.

### CAUTION

- When mounting the product, leave room for adequate working space around it. Failure to do so will make it more difficult to conduct daily inspections or maintenance, which could eventually lead to system shutdown or damage to the product.
- Whenever transporting or installing a heavy product, use a lift or supports to securely support it, and use several people to help lift it and take other precautions to ensure personal safety.
- Do not bring any magnetic media or memory media, or other similar items within one meter of an energized solenoid valve. Doing so creates the risk of damage to data on the magnetic media due to magnetism.
- Do not use a solenoid valve in locations subject to large electrical currents or strong magnetic fields. Doing so could result in erratic operation.
- Oil from a compressor (except from the oil free compressor) can greatly reduce product performance and can even cause functional stoppages. Be sure to install a mist filter before pneumatic equipment to remove oil.
- If an electric leakage occurs on control circuit, it may cause the product to operate unintentionally. Take leak current countermeasures against the control circuit so that the leak current do not exceed the allowance in the product specifications.
- While the product is in operation, avoid touching it with your hands or otherwise approaching too close. Heat generated by the coil can cause burn injury.

### ATTENTION

- When considering the possibility of using this product in

situations or environments not specifically noted in the catalog or instruction manual, or in applications where safety is an important requirement such as in aircraft equipment, combustion equipment, leisure equipment, safety equipment, and other places where human life or assets may be greatly affected, take adequate safety precautions such as allowing plenty of margin for ratings and performance, or fail-safe measures. Contact the sales department at Koganei regarding use in such applications.

- Always check the catalog and other reference materials for product wiring and piping.
- When handling the product, wear protective gloves, safety glasses, safety shoes, and other protective clothing.
- When the product can no longer be used, or is no longer necessary, dispose of it appropriately, according to the "Law Regarding the Disposal and Cleaning of Waste" or other local governmental rules and regulations, as industrial waste.
- Pneumatic equipment can exhibit degraded performance and function over its operating life. Always conduct daily inspections of the pneumatic equipment, and confirm that all requisite system functions are satisfied, to prevent accidents from happening.
- Air leakage of the solenoid valves cannot be cut to zero. Take volume and holding time requirements into consideration when designing pressure (including vacuum) retention in the pressure vessel, and other factors.
- For inquiries about the product, consult your nearest Koganei sales office or Koganei Overseas Department. The addresses and telephone numbers are shown on the back cover of this catalog.
- Attach a muffler to the exhaust port. This will reduce exhaust noise.

### Other precautions

- Always observe the following items.
  1. When using this product in pneumatic systems, always use genuine Koganei parts or compatible parts (recommended parts).  
When conducting maintenance and repairs, always use genuine Koganei parts or equivalent parts (recommended parts). Always observe the prescribed methods and procedures.
  2. Never attempt inappropriate disassembly or assembly of the product relating to basic configurations, or its performance or functions.

Koganei shall not be held responsible for any problems that occur as a result of these items not being properly observed.

### Warranty and General Disclaimer

#### 1. Warranty Period

Koganei warrants this product for a period of no more than 180 days from the date of delivery.

#### 2. Scope of Warranty and General Disclaimer

- (1) The Koganei product warranty covers individual products. When a product purchased from Koganei or from an authorized Koganei distributor malfunctions during the warranty period in a way that is attributable to Koganei's responsibility, Koganei will repair or replace the product free of charge. Even if a product is still within the warranty period, its durability is determined by its operation cycles and other factors. Contact your nearest Koganei sales office or the Koganei overseas department for details.
- (2) Koganei shall not be held responsible for any losses or for any damage to other machinery caused by breakdown, loss of function, or loss of performance of Koganei products.
- (3) Koganei shall not be held responsible for any losses due to use or storage of the product in a way that is outside of the product specifications prescribed in Koganei catalogs and the instruction manual, and/or due to actions that violate the mounting, installation, adjustment, maintenance and other safety precautions.
- (4) Koganei shall not be held responsible for any losses caused by breakdown of the product due to factors outside the responsibility of Koganei, including but not limited to fire, natural disaster, the actions of third parties, and intentional actions or errors by you.

## K2 Series operation principle and symbols

2-port

K2-100SF-□-NL□-JM

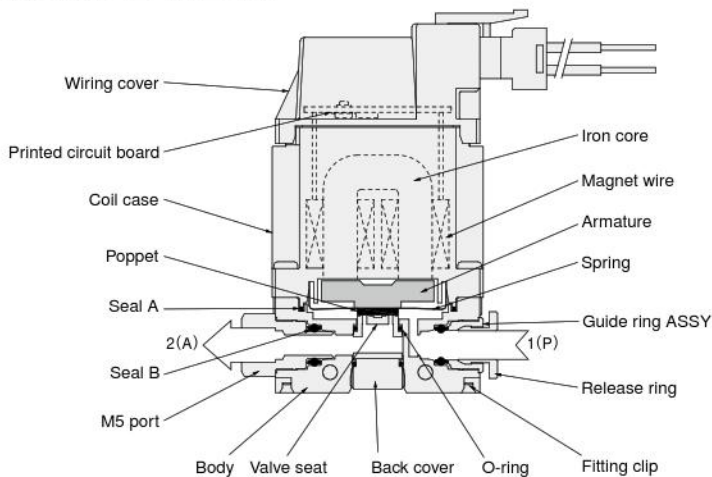

Symbol

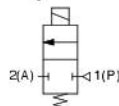

### Materials of major parts

Name	Materials
Iron core	Magnetic steel sheet
Magnet wire	Copper
Coil case	Plastic (PPS)
Wiring cover	Plastic (Polycarbonate)
Printed circuit board	Glass epoxy
Armature	Electromagnetic soft iron (nickel plated)
Spring	
Back cover	Stainless steel
Fitting clip	
Body	Plastic (PPS)
Valve seat	Plastic (PBT)
Poppet	
O-ring	Synthetic rubber (HNBR)
Seal A	
M5 port	Stainless steel
Guide ring ASSY	Brass (electroless nickel plated)
Release ring	Plastic (Polyacetal)
Seal B	Synthetic rubber (FKM)

## Handling instructions and precautions

### Wiring instructions

#### Plug connector connection and disconnection

When connecting the connector, use your finger to insert the connector onto the pin, and push in on the connector until the lever's claw catches the indent of the housing.

When removing the connector, squeeze the lever along with the connector making sure that the lever's claw is disengaged from the indent of the housing, and then pull the connector out.

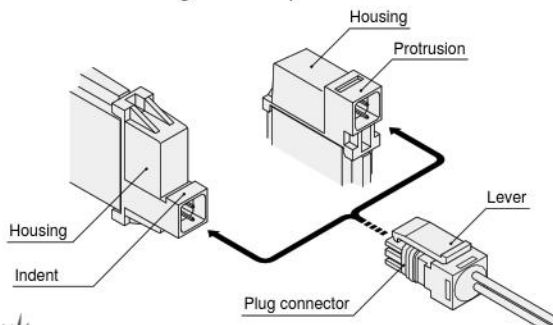

When removing the connector, make sure that the lever's claw is disengaged from the indent of the housing before pulling the connector out. Pulling out the connector while the lever's claw is still engaged will damage the housing.

### Mounting bracket, sub-base

When attaching a mounting bracket to the valve body, use the long mounting screws when attaching to the side, and the short mounting screws when attaching to the bottom.

#### Side attachment



#### Bottom attachment



The recommended tightening torque for the valve mounting screws when mounting a valve on the sub-base is shown on the right.



### Replacing the input port and output port fittings (M5×0.8)

- Use a flat blade screwdriver (3 mm blade width) to pull the fitting clip on the inner side of the fitting from the back of the valve body.
- Remove the fitting to be replaced and remove any part of the seal that remains inside the valve.
- Attach the seal that comes with a new fitting (M5×0.8) onto the fitting, and then insert the fitting into the valve body as far as it will go.
- Push the fitting clip into position as far as it will go. Check to make sure that the fitting clip is pushed in so that at least 1 mm of both of the clips legs are inserted into the bottom of the valve.

Note 1: Failure to securely install the fitting clip creates the risk of the fitting coming off. Take care to install the clip properly and securely.

2: The fitting (M5×0.8) is able to rotate. When connecting piping, use a wrench or other tool to secure the fitting (M5×0.8).

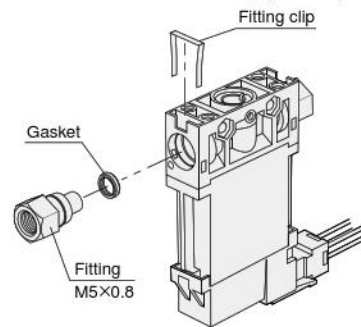

### Tubing

Use of both nylon tubes and urethane tubes is supported.

Use tubes with outside diameter precision within 0.1 mm of the nominal dimensions, and with ovality (difference between major axis and minor axis) within 0.2 mm.

(Use of Koganei tubes is recommended.)



- Do not use extremely soft tubes, which causes a severe drop in pull-out strength.
- Do not use tubes whose outside surface is damaged or scratched. If tubes become damaged after repeated use, cut off the damaged portion.
- Do not subject tubes to sharp bends in the vicinity of fittings. The table below shows minimum bending radius guidelines for nylon tubes.
- Be sure to stop air supply from the air source before attaching or detaching tubes. Also be sure to check that all of the air within the manifold has been exhausted.

Tube size	Minimum bending radius
φ4	20
φ6	30

### Other precautions

Do not rotate screws on the coil portion or on the back cover. Doing so creates the risk of product malfunction, loss of function, or damage.

# Handling instructions and precautions

## Internal circuit

Circuit specifications	Internal circuit
No-protection circuit type (-N)	<p>*Refer to "No-protection circuit type (-N) LED usage precautions" on the top right if using LED.</p>
Surge absorbing type (-Z)	
Power saving type (-L) See Note 1 to Note 5.	
PLC drive type (-R) See Note 1 to Note 5.	<p>*1: Lead wire color in ( ) parentheses is when cable is selected *2: Surge absorbing circuit for electric power specifications -02 and -04 Surge absorbing circuit and power saving circuit for electric power specifications -09 and -24</p>
Pulsed blow type (-X)	<p>*When the external input is on, the solenoid valve turns on and off according to the set frequency and duty ratio. For details, see pages 9 and 10.</p>

Do not perform a megger test between pins.

- Note 1: With the power saving type (-L) and PLC drive type (-R), avoid use with switches that can cause chattering. Such switches can also cause incorrect power saving circuit operation.
- 2: Noise may be generated in the area around the coil while the valve is energized. This is due to the properties of power saving circuit and does not indicate malfunction of the valve.
- 3: When using a lead wire for the power supply line of the power saving type (-L) and PLC drive type (-R), use a lead wire that is no more than 1 meter in length. When using a cable, use a cable that is at least 1 meter and no more than 4 meters in length.
- 4: When wiring the power supply line of the power saving type (-L) and PLC drive type (-R), be sure to use a twisted pair cable if the terminal block is relayed. The cable should be a total length of at least 1 meter and no more than 4 meters in length from the power supply.

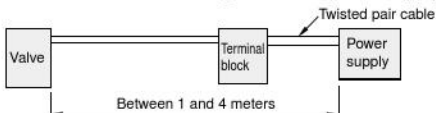

5: When wiring the power supply line of the power saving type (-L) and PLC drive type (-R), installing a filter or other intermediate device can cause improper power saving circuit operation.

## No-protection circuit type (-N) LED usage precautions

Using the same power supply to operate no-protection circuit type solenoid valve's LED indicators and coil operation creates the risk of LED damage due to counter electromotive force generated when the coil is off. In this case, provide protection circuit (Diagram 1).

Note: Response times shown in the catalog specifications are values when LEDs are not used.

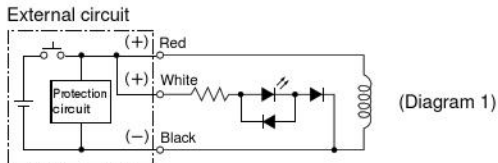

## Pulsed blow type (-X) externally connected circuit

Refer to the diagram below (Diagram 2) when wiring to the pulsed blow type.

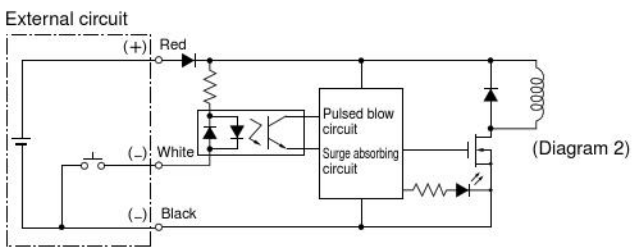

## Power saving circuit current waveforms

The power line waveform for the power saving type (-L) and PLC drive type (-R) with -09, -24 power specifications is shown below.

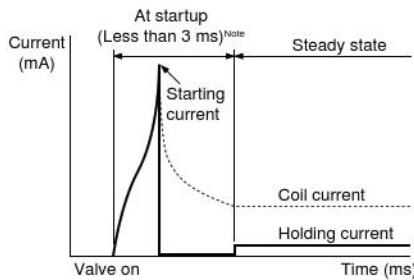

Note: The startup time varies depending on the model.

## Installation

WARNING

1. Installing valves side-by-side or with a manifold will generate large amounts of coil heat. Provide at least 1 mm of space between coils.
2. Coils generate heat. Avoid energizing coils without applying air. During use in combination with a nozzle or other type of throttling valve, provide an air flow of at least 5 l/min while the valve is energized.
3. Allowing ferromagnetic material to come into contact with the solenoid valve (coil) can cause erratic operation. Keep such materials at least 1 mm away from solenoid valves.

## Restrictions on 4 W power specification type continuous energizing time

WARNING

In the case of the 4 W power specification type, be sure to use a continuous energizing time that is below the voltage waveform shown below. A longer energizing time results in heat build-up due to coil heat generation, which can lead to damage or burnout. Contact Koganei for details.

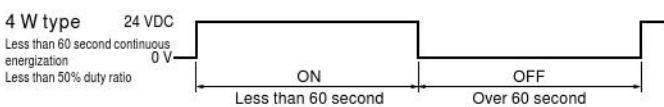

## Pulsed blow type (-X) operation method



When configuring frequency and duty ratio settings using a pulsed blow type, always conduct a safety check of the area of machine operation before supplying air or electricity to the device and before starting operation. The actuator may move unintentionally and may result in damage or personal injury caused by contact with moving parts.

### Setting range of pulsed blow type (-X)

When using a pulsed blow type and configuring frequency and duty ratio settings, there is a range in which settings cannot be configured due to on/off response delay.

Configure frequency and duty ratio settings using the graph of the range where settings can be configured as a guide.

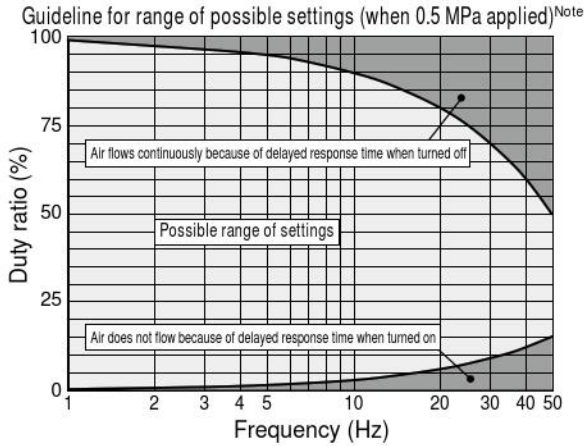

Note: The above two graphs show reference values for K2 Series types with an ON response time of 3.0 ms and an OFF response time of 10 ms.

### Air consumption guidelines using the pulsed blow type (-X)

The graph below shows the relationship between the frequency and duty ratio, and the air consumption volume due to ON/OFF response delay, assuming an air consumption volume during continuous energizing (100% duty ratio) of 100%, when a pulsed blow type is used and the air consumption volume is controlled. Configure frequency and duty settings using the graph below as a guide.

\*The duty ratio is the ratio of energizing ON time within one cycle (ON and OFF).

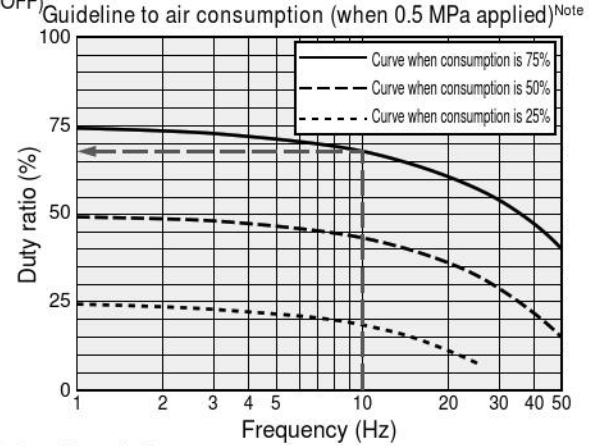

### Explanation of diagrams

A duty ratio of approximately 68% is required when the frequency is 10 Hz and the air consumption volume is 75%.

## Infrared remote control and program specifications

### Remote control program

Item	Manufacturer setting
Manufacturer code (remote control setting)	Toshiba (for analog TV)

### Remote control functions (Recommended remote control unit: Ohm Electric Inc. ORC-02DG)

Function	Buttons	Description of function
Lock release	Press [0/10] <sup>Note 1</sup> four times	Releases infrared receive lock and changes settings. (External input must be OFF to release lock.)
ON/OFF	[Power]	While infrared input is OFF and after releasing lock, valve oscillation can be turned ON or OFF with the remote control.
Settings by value input	[1] to [9], [0/10] <sup>Note 1</sup>	Use these buttons to input values when changing frequency (Hz) and duty ratio (%) settings.
	[11] (Frequency)	Press after inputting a value to change the frequency (Hz).
	[12] (Duty ratio)	Press after inputting a value to change the duty ratio (%). A duty ratio of 100% is continuous energizing.
Settings by variable input	[Channel +/-]	Change the frequency (Hz) in units of 1 (Hz). With key repeat <sup>Note 2</sup> .
	[Volume +/-]	Change the duty ratio (%) in units of 1 (%). With key repeat <sup>Note 3</sup> .
Registration	[Change input]	Registers setting values (frequency (Hz), duty ratio (%)) that have been changed and lock infrared receive. Registering settings causes settings to be saved even if the power supply to the valve is cut off.
Registered value recall	[Mute]	Recalls the most recently registered settings.

Note 1: Though the [0/10] button is used as a [0] button, the marking of the button depends on the remote control being used.

If your remote control does not have a [0] button, the [10] button is used for [0].

2: Holding down a button for more than 0.5 seconds will scroll the frequency value upwards or downwards.

3: Holding down a button for more than 0.5 seconds will scroll the duty ratio value upwards or downwards.

### Valve LED indicators

During valve operation	The valve LED light timing is the same as the oscillation frequency and duty ratio.
During remote control input	When lock is released, aiming the remote control at the valve and operating a button causes the valve LED to light or go out for 0.1 seconds.
During lock release	Valve LED does not light with the first press of [0/10], does not light with the second press of [0/10], does not light with the third press of [0/10], and lights for 0.1 seconds with the fourth press of [0/10].

### Operation precautions

1	When configuring settings, make sure that 24 VDC of power is supplied between the solenoid valve input (+) and GND (-).
2	Make sure that the remote control signal emitter is aimed at the valve when operating remote control buttons. Settings will not be configured if you operate the remote control without aiming at the valve.
3	Another pulsed blow type valve that is near the valve whose settings are being configured can cause interference in the infrared signal during remote control input. To avoid interference, be sure to disconnect the connectors and cut off the power supply of all valves except for the one being configured.
4	Perform remote control input slowly and carefully. Due to delay in the receive process, quick operation may result in incorrect input.
5	Input each value within 10 seconds. Input will be ignored after 10 seconds.
6	If you make a mistake during value input, wait for more than 10 seconds after the last input and then input it again.
7	Remote control input is not supported while a valve is ON by external input (lock release is also not supported).
8	The infrared receive lock function is automatically operational when power is turned on, so release the lock before configuring settings.
9	Executing "Registration" while configuring settings with a remote control automatically executes [Valve stop], performs memory registration, and locks infrared reception.
10	Inputting from an external source while configuring settings with the remote control automatically locks memory registration and infrared reception, and then switches to operation by external input.
11	If the power supply is cut while settings are being configured with a remote control but have not been registered yet, the unregistered settings are discarded and previously registered settings are restored.

## Operational flow with a remote control

※Initial settings when shipped are 10 Hz frequency and 10% duty ratio. Applicable buttons are shown in ⟨ ⟩ brackets.

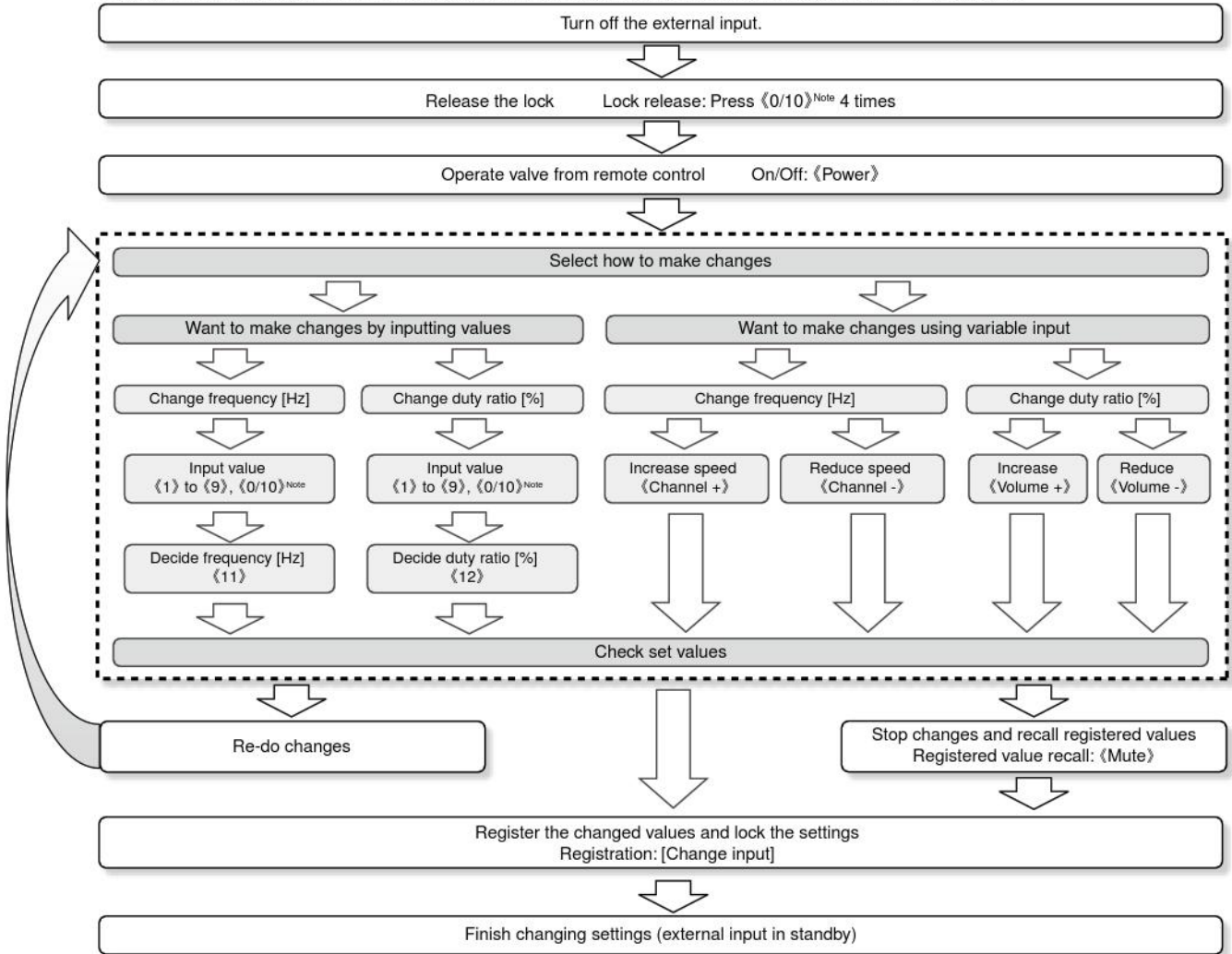

Note: Though the ⟨0/10⟩ button is used as a "0" button, the marking of the button depends on the remote control being used. If your remote control does not have a "0" button, the "10" button is used for "0".

## Recommended remote control buttons

**CAUTION** Make sure that the remote control signal emitter is aimed at the valve when operating remote control buttons.

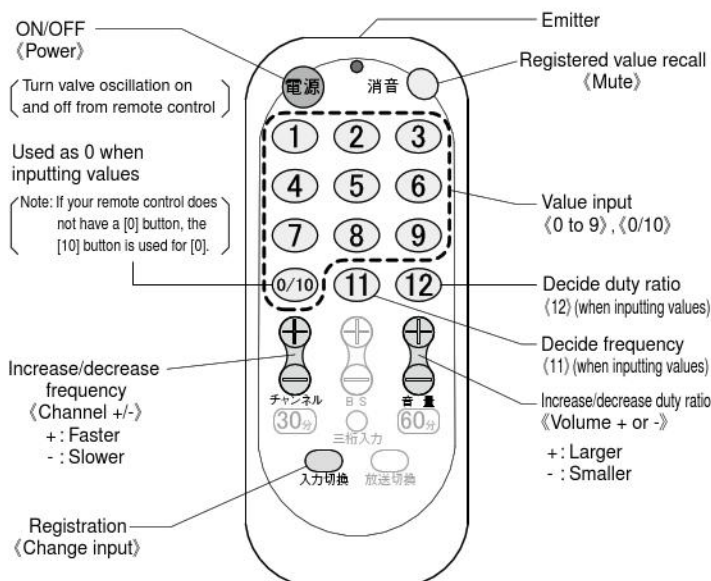

### To input values to do settings

Example 1: To set 5 Hz as the operating frequency of the valve.

⑤ → ⑪  
(Decide frequency)

Example 2: To set 10 Hz as the operating frequency of the valve.

① → ① → ⑪  
(Decide frequency)

Example 3: To set the duty ratio of the valve to 25%.

② → ⑤ → ⑫  
(Decide duty ratio)

(Recommended remote control unit: Ohm Electric Inc. ORC-02DG)

## K2 series specifications

### Direct piping

Applications		For air blow										For high-speed sorting															
Item	Basic model	K2-100SF-02		K2-100SF-04 <sup>Note 5</sup>			K2-100HF-02			K2-100HF-04 <sup>Note 5</sup>		K2-100HF-09			K2-100LF-09		K2-100LF-24		K2-100SF-09		K2-100SF-24		K2-100HF-24 (Special specifications) <sup>Note 6</sup>				
	Circuit specifications	-N	-Z	-R	-X	-N	-Z	-R	-X	-N	-Z	-R	-X	-N	-Z	-R	-X	-L	-R	-L	-R	-L	-R	-L	-R	-L	-R
Media		Air/inert gas										Air/inert gas															
Operation system		Direct operated										Direct operated															
Number of ports		2										2															
Number of positions		2										2															
Valve function		Normally closed (NC)										Normally closed (NC)															
Flow rate characteristics	Sonic conductance C dm <sup>3</sup> /(s·bar)	0.2		0.3			0.3			0.45		0.5			0.2		0.2		0.3		0.3		0.4				
	Effective area [Cv] <sup>Note 1</sup> mm <sup>2</sup>	1.0 [0.06]		1.5 [0.08]			1.5 [0.08]			2.3 [0.13]		2.5 [0.14]			1.0 [0.06]		1.0 [0.06]		1.5 [0.08]		1.5 [0.08]		2.0 [0.11]				
Port size		φ4 mm quick fitting, M5×0.8										φ4 mm quick fitting, M5×0.8															
Lubrication		Not required										Not required															
Operating pressure range MPa		0.2 to 0.7					0.2 to 0.5					0.2 to 0.5					0.2 to 0.4										
Proof pressure MPa		1.05										1.05															
Response time <sup>Note 2, Note 3</sup>	ON	ms		3.0			2.5			3.0		3.0			2.0			0.8		0.4		0.8		0.5		0.5	
	OFF	Max ms		1	1.5	10	1	1.5	10	1	1.5	10	1	1.5	10	8	1.5	1	1	1	1	1	1	1	1	1	
Maximum operating frequency <sup>Note 4</sup> Hz		200	100	50	200	100	50	200	100	50	200	100	50	50	300	400	300	400	300	400	300	400	300	400			
Operating temperature range (atmosphere and media) °C		0 to 50 (non-condensation)										0 to 50 (non-condensation)															
Shock resistance m/s <sup>2</sup>		100										100															
Mounting direction		Any										Any															
Protection structure		IP67 equivalent										IP67 equivalent															
Operating life Operations		500 million (under Koganei test conditions)										1 billion (under Koganei test conditions)															
Mass g		33 for piping specifications -J4, 37 for -M5, 35 for -JM (When lead wire length is 300 mm.)										33 for piping specifications -J4, 37 for -M5, 35 for -JM (When lead wire length is 300 mm.)															

### Base piping

Applications		For air blow										For high-speed sorting														
Item	Basic model	K2-100SA-02		K2-100SA-04 <sup>Note 5</sup>			K2-100HA-02			K2-100HA-04 <sup>Note 5</sup>		K2-100HA-09			K2-100LA-09		K2-100LA-24		K2-100SA-09		K2-100SA-24		K2-100HF-24 (Special specifications) <sup>Note 6</sup>			
	Circuit specifications	-N	-Z	-R	-X	-N	-Z	-R	-X	-N	-Z	-R	-X	-N	-Z	-R	-X	-L	-R	-L	-R	-L	-R	-L	-R	-L
Media		Air/inert gas										Air/inert gas														
Operation system		Direct operated										Direct operated														
Number of ports		2										2														
Number of positions		2										2														
Valve function		Normally closed (NC)										Normally closed (NC)														
Flow rate characteristics	Sonic conductance C dm <sup>3</sup> /(s·bar)	0.26		0.4			0.4			0.54		0.6			0.2		0.2		0.3		0.3		0.4			
	Effective area [Cv] <sup>Note 1</sup> mm <sup>2</sup>	1.3 [0.07]		2.0 [0.11]			2.0 [0.11]			2.7 [0.15]		3.0 [0.17]			1.0 [0.06]		1.0 [0.06]		1.5 [0.08]		1.5 [0.08]		2.0 [0.11]			
Port size		φ6mm quick fitting (-25 specification)										φ6mm quick fitting (-25 specification)														
Lubrication		Not required										Not required														
Operating pressure range MPa		0.2 to 0.7					0.2 to 0.5					0.2 to 0.5					0.2 to 0.4									
Proof pressure MPa		1.05										1.05														
Response time <sup>Note 2, Note 3</sup>	ON	ms		3.0			2.5			3.0		2.0			0.8		0.4		0.8		0.5		0.5			
	OFF	Max ms		1	1.5	10	1	1.5	10	1	1.5	10	8	1.5	1	1	1	1	1	1	1	1	1	1		
Maximum operating frequency <sup>Note 4</sup> Hz		200	100	50	200	100	50	200	100	50	200	100	50	100	300	400	300	400	300	400	300	400	300	400		
Operating temperature range (atmosphere and media) °C		0 to 50 (non-condensation)										0 to 50 (non-condensation)														
Shock resistance m/s <sup>2</sup>		100										100														
Mounting direction		Any										Any														
Protection structure		IP67 equivalent										IP67 equivalent														
Life Operations		500 million (under Koganei test conditions)										1 billion (under Koganei test conditions)														
Mass g		34, 56 (with sub-base) (When lead wire length is 300 mm.)										34, 56 (with sub-base) (When lead wire length is 300 mm.)														

Note 1: Effective area values are calculated values. They are not measured values.

2: Values when air pressure is 0.5 MPa. 0.4 MPa in the case of K2-100H□-24 (special specifications).

3: No-protection circuit type (-N) response times are values when LEDs are not used.

4: Contact Koganei when you wish to operate a valve in excess of this maximum operating frequency.

5: Continuous energizing time is limited. For details, see page ⑩.

6: For operating conditions and ordering procedures, you will need to consult with Koganei. Contact your nearest Koganei sales office.

# K2 series electrical specifications

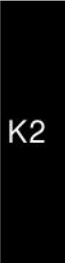

Circuit specifications		No-protection circuit type -N		Surge absorbing type -Z		Power saving type -L <sup>Note 1</sup>			PLC drive type -L <sup>Note 1</sup>				Pulsed blow type -X <sup>Note 1</sup>		
Power specifications (Flow rate type)		-02	-04 <sup>Note 3</sup>	-02	-04 <sup>Note 3</sup>	-09 (Standard) (Low flow rate)	-09 (High flow rate)	-24	-02	-04 <sup>Note 3</sup>	-09 <sup>Note 2</sup> (Standard) (Low flow rate)	-09 <sup>Note 2</sup> (High flow rate)	-24 <sup>Note 2</sup>	-02	-04 <sup>Note 3</sup>
Item		24 VDC													
System		DC solenoid (parallel)													
Operating voltage range		V		21.6 to 26.4 (24.0±10%)		22.8 to 25.2 (24.0±5%)		21.6 to 26.4 (24.0±10%)		22.8 to 25.2 (24.0±5%)		21.6 to 26.4 (24.0±10%)		21.6 to 26.4 (24.0±10%)	
Power specifications -02, -04	Current value (when rated voltage is applied) mA	84	167	84	167	—		84	167	—		—		90	170
	Power consumption W	2.0	4.0	2.0	4.0	—		2.0	4.0	—		—		2.2	4.1
Power specifications -09, -24	Current value (when rated voltage is applied)	Starting mA	—		—		380	1000	—		380	1000	—		
		Holding mA	—		—		42 or less	63 or less	—		42 or less	63 or less	—		
	Power consumption	Starting W	—		—		9.1	24	—		9.1	24	—		
		Holding W	—		—		1 or less	1.5 or less	—		1 or less	1.5 or less	—		
Vcc current value (standby)		mA		—		—		—		—		—		6 (24 VDC)	
External input	PLC input Rated voltage	V		—		—		—		5 to 24 DC ±10%		—		Shorted within valve	
	PLC input Rated current	mA		—		—		—		23 (24 VDC)		—		5 (24 VDC)	
	Contact type	—		—		—		—		NPN open collector		—		—	
Allowable circuit leak current		mA		3.5	7	3	3		—		1		0.25		
LED circuit consumption current (when connected)		mA		4		—		—		(as standard)		—		—	
Insulation resistance		MΩ		—		—		—		100 or greater		—		—	
LED indicator color		—		—		—		—		Red		—		—	
Surge protection		None		—		—		Surge absorbing transistor		—		—		Flywheel diode	

Note 1: Surge absorbing circuit is provided as standard in the case of circuit specifications -L, -R, and -X.  
 Note 2: Power saving circuit is built-in in the case of power specifications -09 and -24 of circuit specifications -R (PLC drive type).  
 Note 3: Continuous energizing time is limited. For details, see page 8.

# K2 series flow rate

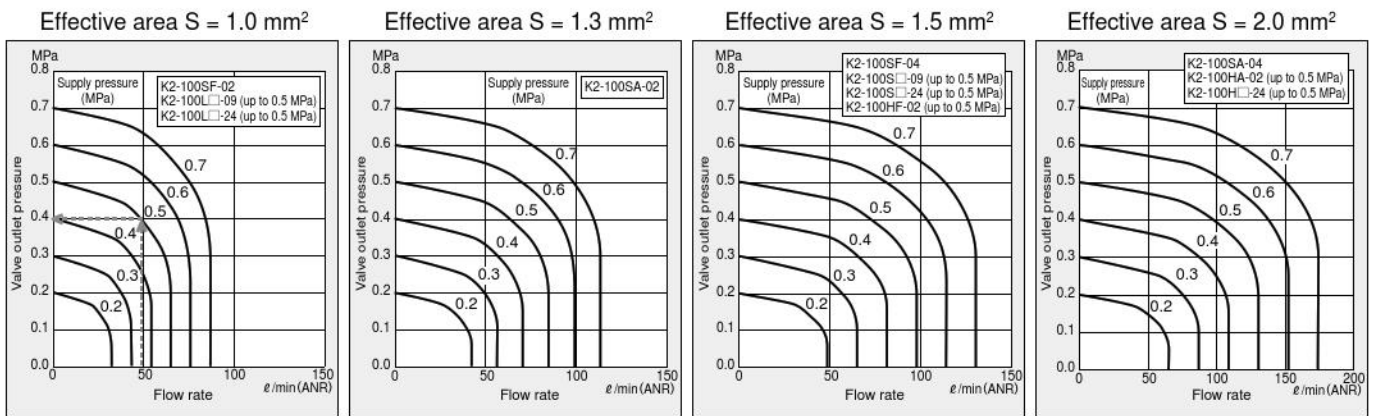

Explanation of diagrams  
 At supply pressure of 0.5 MPa, and flow rate of 49 l/min (ANR), valve outlet pressure becomes 0.4 MPa.

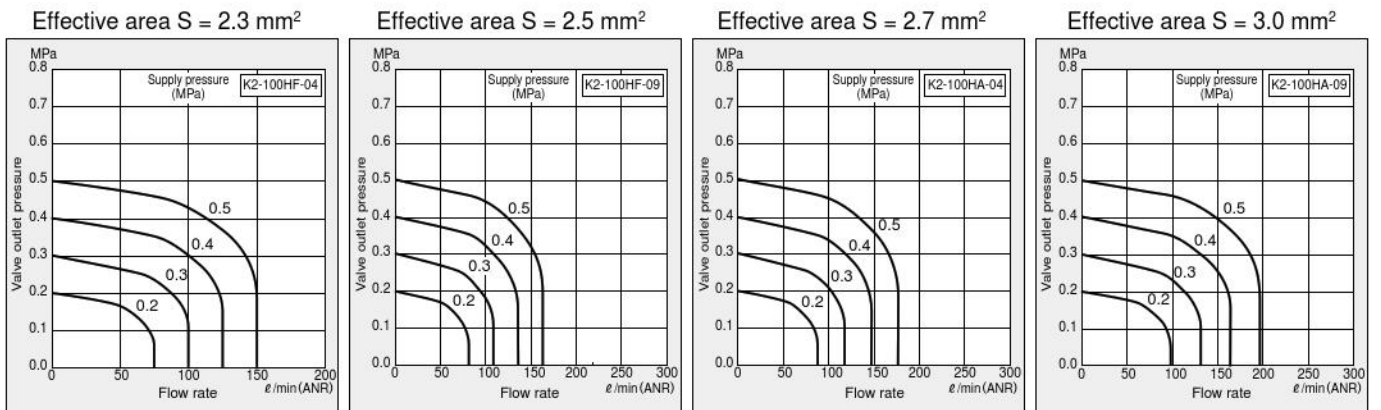

# K2 Series order codes

- Basic model**
- K2-100SF: Direct piping, 2-port normally closed (NC), standard flow rate type
  - K2-100HF: Direct piping, 2-port normally closed (NC), high flow rate type
  - K2-100LF: Direct piping, 2-port normally closed (NC), low flow rate type
  - K2-100SA: Base piping, 2-port normally closed (NC), standard flow rate type
  - K2-100HA: Base piping, 2-port normally closed (NC), high flow rate type
  - K2-100LA: Base piping, 2-port normally closed (NC), low flow rate type

**Power specifications**

- 02: 2 W
- 04: 4 W<sup>Note 1</sup>
- 09: 9 W (with power saving circuit)
- 24: 24 W (with power saving circuit)

**Circuit specifications**

- N: No-protection circuit type (3-wire) (Without surge absorbing circuit)
- Z: Surge absorbing type (2-wire) (With surge absorbing circuit)
- L: Power saving type (2-wire) (With surge absorbing circuit)
- R: PLC drive type (4-wire) (With surge absorbing circuit)
- X: Pulsed blow type (3-wire) (With surge absorbing circuit)

**Wiring specifications**

- S0: IP67 S-type plug connector, 300 mm lead wire
- S1: IP67 S-type plug connector, 1000 mm lead wire
- S3: IP67 S-type plug connector, 3000 mm lead wire<sup>Note</sup>  
Note: Cable length is 3000 mm in the case of power saving type -L and PLC drive type -R.
- SN: IP67 S-type plug connector, no connector
- L0: IP67 L-type plug connector, 300 mm lead wire
- L1: IP67 L-type plug connector, 1000 mm lead wire
- L3: IP67 L-type plug connector, 3000 mm lead wire<sup>Note</sup>  
Note: Cable length is 3000 mm in the case of power saving type -L and PLC drive type -R.
- LN: IP67 L-type plug connector, no connector

**Piping specifications**

- J4: φ4 quick fitting
- J4B: φ4 quick fitting, with mounting bracket
- M5: M5×0.8
- M5B: M5×0.8, with mounting bracket
- JM: 1 (P) port φ4 quick fitting, 2 (A) port M5×0.8
- JMB: 1 (P) port φ4 quick fitting, 2 (A) port M5×0.8, with mounting bracket
- Blank: No sub-base
- 25: With sub-base (φ6 quick bracket)<sup>Note</sup>  
Note: Contact your nearest Koganei sales office concerning use in an ozone environment.

	Basic model	Power specifications	Circuit specifications	Wiring specifications	Piping specifications	Voltage
Direct piping	K2-100SF K2-100HF <sup>Note 2</sup>	-02 -04 <sup>Note 1</sup>	-N -Z -R	S0 L0 S1 L1 S3 L3 SN LN	-J4 -J4B -M5 -M5B -JM -JMB	24 VDC
			-X	S0 S3 S1 SN		
	K2-100LF	-09 -24 <sup>Note 2</sup>	-L -R	S0 L0 S1 L1 S3 L3 SN LN		
Base piping	K2-100SA K2-100HA <sup>Note 2</sup>	-02 -04 <sup>Note 1</sup>	-N -Z -R	S0 L0 S1 L1 S3 L3 SN LN	Blank -25	24 VDC
			-X	S0 S3 S1 SN		
	K2-100LA	-09 -24 <sup>Note 2</sup>	-L -R	S0 L0 S1 L1 S3 L3 SN LN		

Note 1: Continuous energizing time is limited. For details, see page ①.

Note 2: K2-100HF-24 and K2-100HA-24 are special specification products. For operating conditions and ordering procedures, you will need to consult with Koganei. Contact your nearest Koganei sales office.

## K2 Series additional parts order codes

### Mounting bracket



K210-21: Mounting bracket (with screws), 1 set

### M5 port



K210-M5: Two M5x0.8 fittings (with gaskets and fitting clips)

### Sub-base



K210-25: Sub-base (with  $\phi 6$  quick fitting), 1 set  
\*Contact your nearest Koganei sales office concerning use in an ozone environment.

### Block-off plate



K210-BP: Block-off plate (with o-ring and screws), 1 set

### Connector, lead wire type



K210-P20: IP67 plug connector, lead wire (2-wire) length: 300 mm  
K210-P21: IP67 plug connector, lead wire (2-wire) length: 1000 mm  
K210-P23: IP67 plug connector, lead wire (2-wire) length: 3000 mm<sup>Note 1</sup>  
Note 1: Use a cable type for a 3000 mm length for the power saving type (-L).



K210-P30: IP67 plug connector, lead wire (3-wire) length: 300 mm  
K210-P31: IP67 plug connector, lead wire (3-wire) length: 1000 mm  
K210-P33: IP67 plug connector, lead wire (3-wire) length: 3000 mm



K210-P40: IP67 plug connector, lead wire (4-wire) length: 300 mm  
K210-P41: IP67 plug connector, lead wire (4-wire) length: 1000 mm

### Connector, cable type



K210-C31: IP67 plug connector, cable (3-wire) length: 1000 mm<sup>Note 2</sup>  
K210-C33: IP67 plug connector, cable (3-wire) length: 3000 mm<sup>Note 2</sup>  
K210-C35: IP67 plug connector, cable (3-wire) length: 5000 mm<sup>Note 2</sup>  
Note 2: In the case of 2-wire specifications (-L, -Z), cut the white lead wire to use.



K210-C41: IP67 plug connector, cable (4-wire) length: 1000 mm  
K210-C43: IP67 plug connector, cable (4-wire) length: 3000 mm

K2 series dimensions (mm)

K2-100□F-□-□L0-J4 (direct piping type)

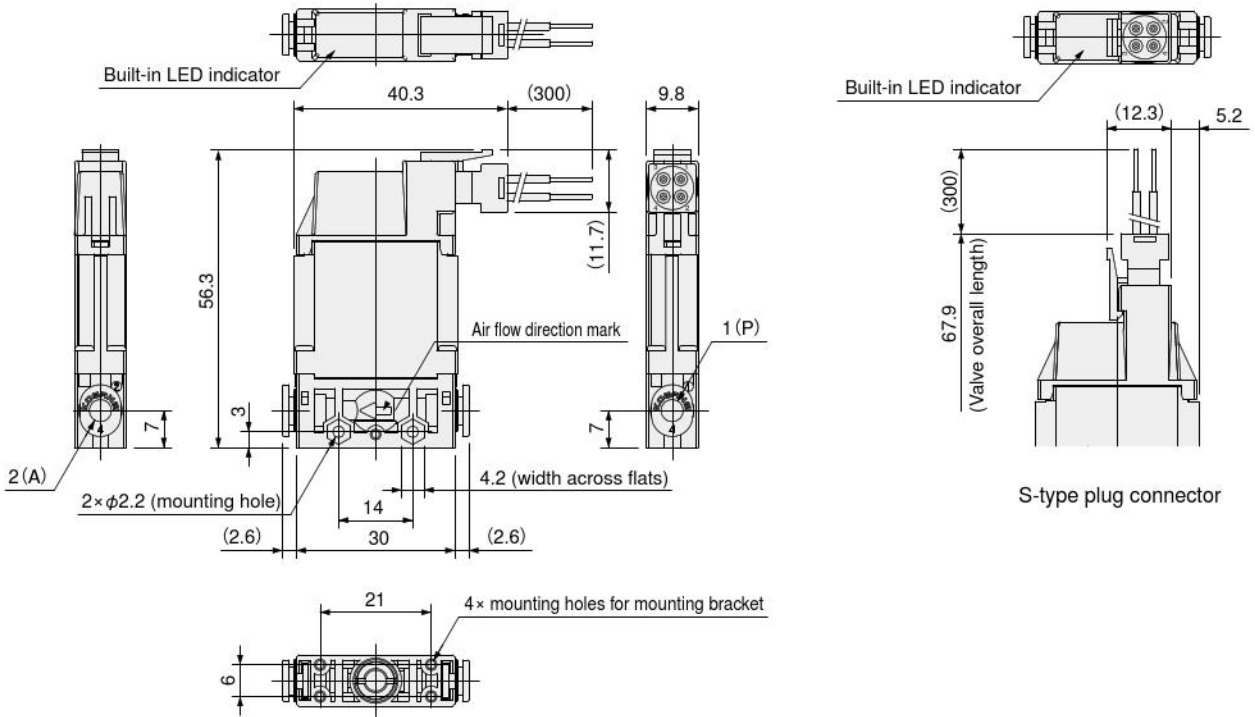

-M5 (when using M5 port)

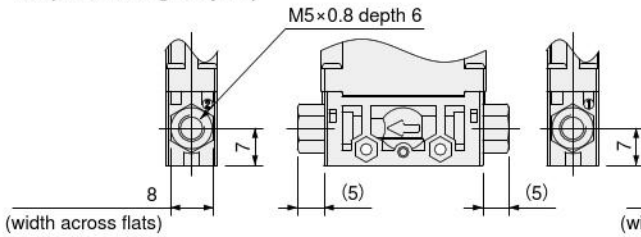

When -JM selected (when using φ4 quick fitting and M5 port)

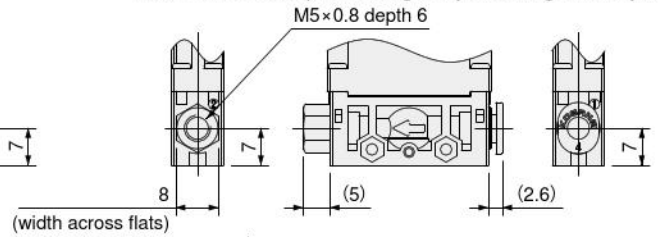

Bracket (K210-21): Attached to side

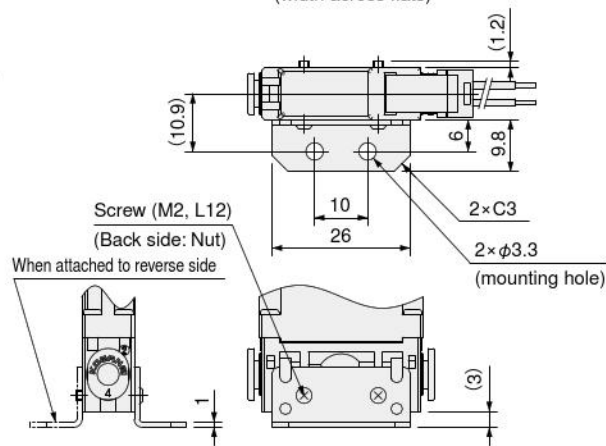

Bracket (K210-21): Attached to bottom

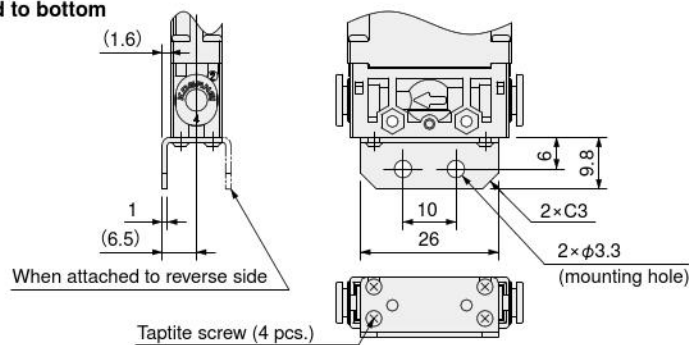

# K2 series dimensions (mm)

## K2-100□A-□-□L0-25 (base piping type)

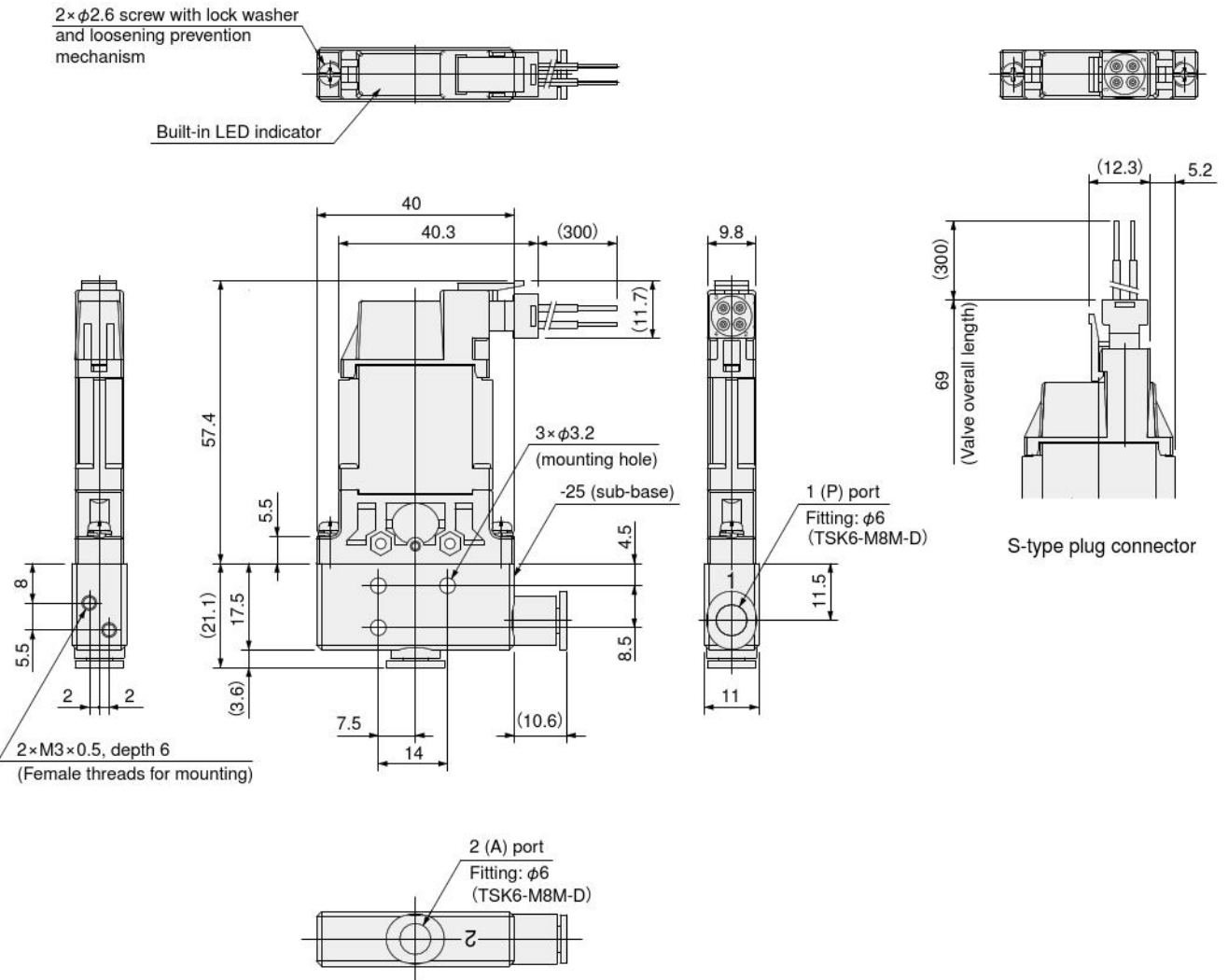

### Manifold installation dimensions (11 mm minimum pitch for valve installation when mounted on manifold)

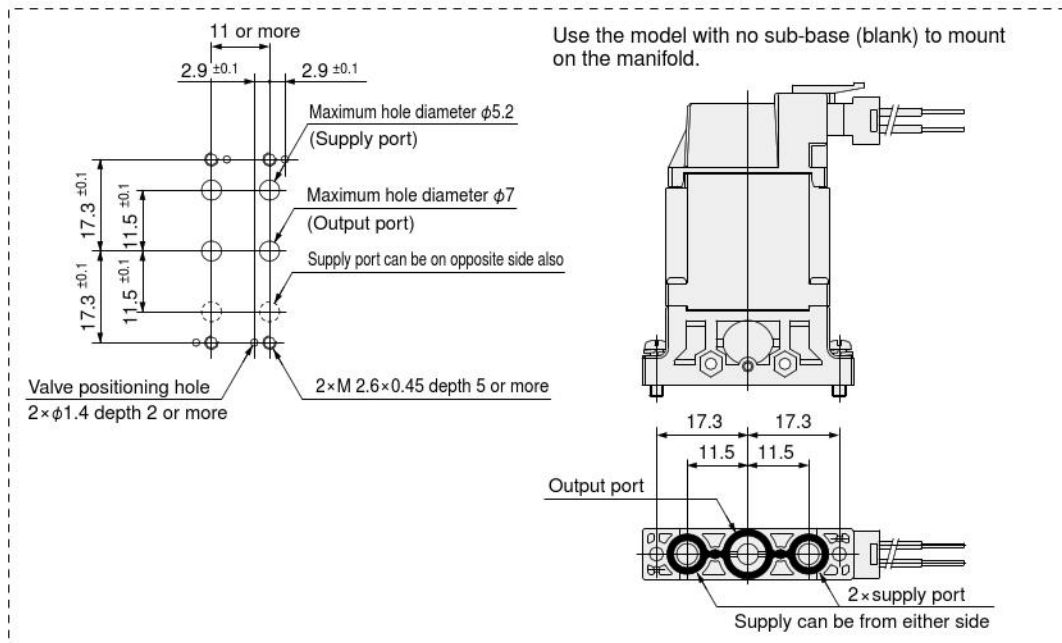

K2

## K3/K4 operation principle and symbols

3-port

K3-100SF-□-NL□-M5C

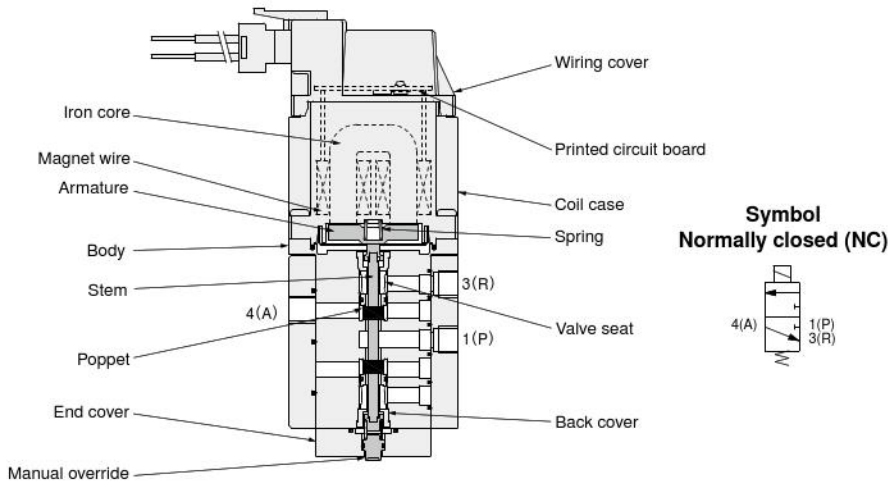

### Materials of major parts

Name	Materials
Iron core	Magnetic steel sheet
Magnet wire	Copper
Coil case	Plastic (PPS)
Wiring cover	Plastic (Polycarbonate)
Printed circuit board	Glass epoxy
Body	Plastic (PPS)
Stem	Stainless steel
Back cover	Stainless steel
Valve seat	Plastic (nylon)
End cover	Plastic (PBT)
Manual override	Plastic (POM)
Armature	Electromagnetic soft iron (nickel plated)
Poppet	Synthetic rubber (HNBR)

K3-100SF-□-NL□-M5D

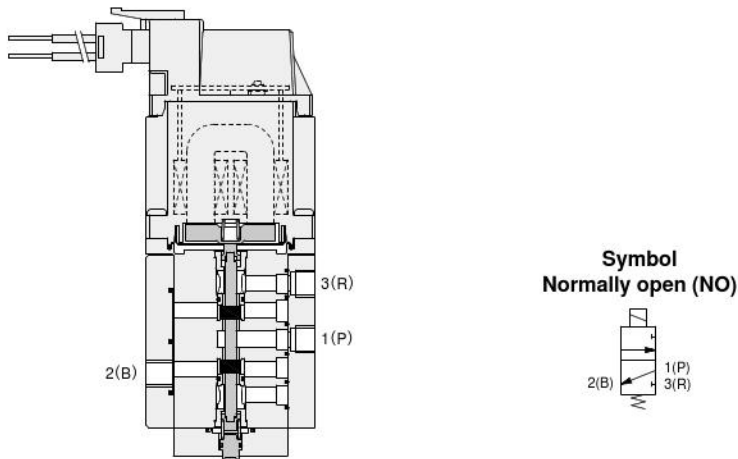

4-port

K4-100SF-□-NL□-M5F

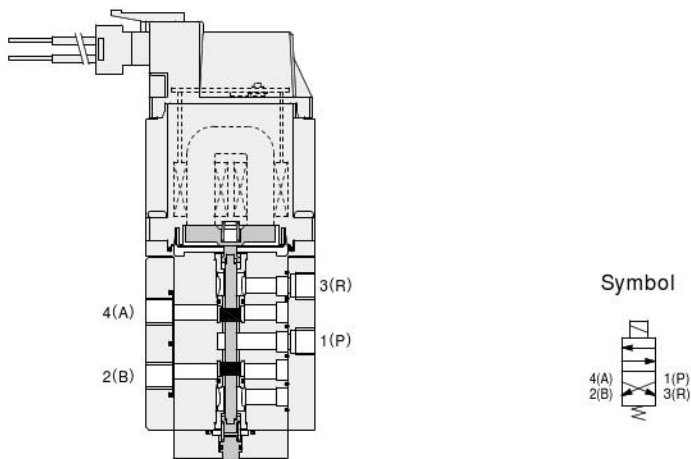

# Handling instructions and precautions

## Wiring instructions

### Plug connector connection and disconnection

When connecting the connector, use your finger to insert the connector onto the pin, and push in on the connector until the lever's claw catches the indent of the housing.

When removing the connector, squeeze the lever along with the connector making sure that the lever's claw is disengaged from the indent of the housing, and then pull the connector out.

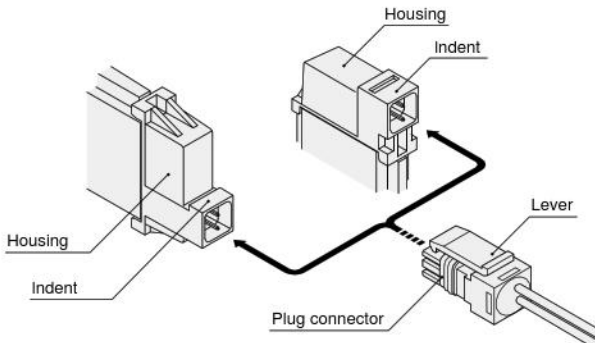

When removing the connector, make sure that the lever's claw is disengaged from the indent of the housing before pulling the connector out. Pulling out the connector while the lever's claw is still engaged will damage the housing.

## Using the 3-port valve NC and NO when using a sub-base

A plug comes with the K3 Series (3-port valve) -A2 specification (sub-base included), so the plug can be used to select the NC/NO setting.

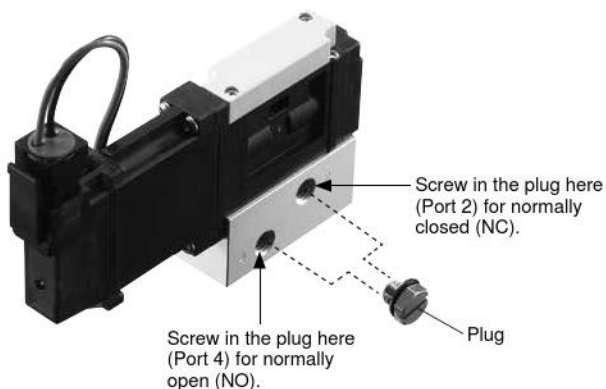

## Piping specifications

Cannot be used unless piping specifications filled in. Be sure to mount an air supply block or sub-base on the inlet side, and a fitting block, female thread block or plate on the outlet side.

\*When mounting an air supply block on the inlet side, mount a fitting block or female thread block on the outlet side. When mounting a sub-base on the inlet side, mount a plate on the outlet side.

## Mounting a valve on the air supply block and sub-base

The recommended tightening torque for the valve mounting screws when mounting a valve on the air supply block or sub-base is 7 N·cm.



## Precautions when using a plate, fitting block, or female thread block

1. When mounting a plate, fitting block, or female thread block following purchase of a valve for which the piping specification is blank, the recommended tightening torque for the mounting screws (tapping screws) is 7 N·cm.

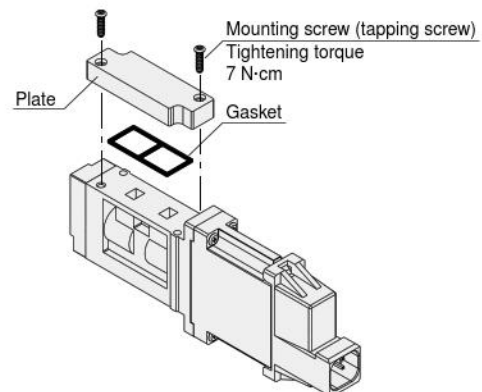

When screwing in a mounting screw (tapping screw), tighten the screw so it is parallel with the pilot hole of the body. After tightening a screw, check to make sure it is not loose. Exceeding the recommended tightening torque or tightening a tapping screw at an angle can cause deformation or cracking of the body.

2. Do not remove a plate, fitting block, or female thread block that is later mounted or mounted at the factory.



The product is no longer under warranty if the plate, fitting block, or female thread block is removed or reassembled.

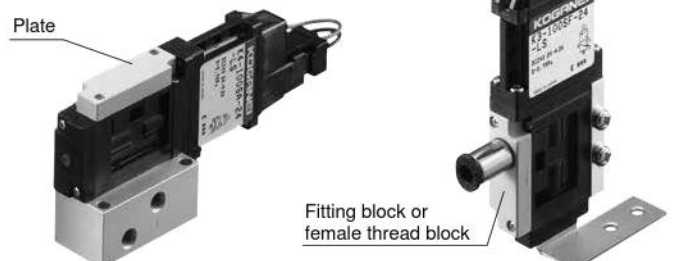

K3  
K4

# Handling instructions and precautions

## When mounting a fitting on the female thread block

When mounting a fitting on the female thread block, hold the female thread block to mount the fitting. Tightening torque is 10N•cm.



## Manual override operation

Press the manual override as far as it will go to operate it. The valve is in the same state when energizing while the manual override is pressed. Releasing the manual override causes it to return.



Performing manual override operation operates connected devices, so be sure to confirm that doing so does not create any danger before pressing the manual override.

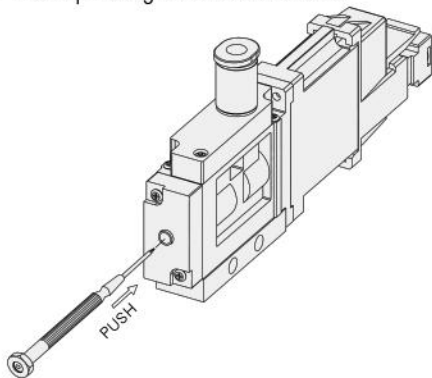

## Tubing

Use of both nylon tubes and urethane tubes is supported. Use tubes with outside diameter precision within 0.1 mm of the nominal dimensions, and with ovality (difference between major axis and minor axis) within 0.2 mm. (Use of Koganei tubes is recommended.)



- Do not use extremely soft tubes, which causes a severe drop in pull-out strength.
- Do not use tubes whose outside surface is damaged or scratched. If tubes become damaged after repeated use, cut off the damaged portion.
- Do not subject tubes to sharp bends in the vicinity of fittings. The table below shows minimum bending radius guidelines for nylon tubes.
- Be sure to stop air supply from the air source before attaching or detaching tubes. Also be sure to check that all of the air within the manifold has been exhausted.

mm

Tube size	Minimum bending radius
φ4	20
φ6	30

## Vacuum holding

For K3-100V□ type, there is a minute amount of leakage at vacuum, but this is considered to be permissible. When vacuum holding is required, use a vacuum storage tank (chamber, etc.) and confirm that sufficient vacuum pickup force is maintained.

### Standard vacuum circuitry

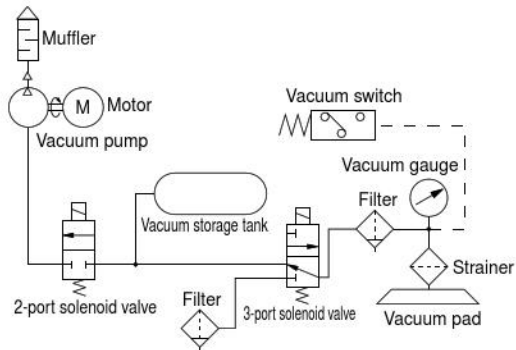

# Handling instructions and precautions

## Internal circuit

Circuit specifications	Internal circuit
No-protection circuit type (-N)	<p>*Refer to "No-protection circuit type (-N) LED usage precautions" on the top right if using LED.</p>
Surge absorbing type (-Z)	
Power saving type (-L)	<p>See Note 1 to Note 5.</p>
PLC drive type (-R)	<p>*1: Lead wire color in ( ) parentheses is when cable is selected *2: Surge absorbing circuit for electric power specifications -02 and -04 Surge absorbing circuit and power saving circuit for electric power specifications -24</p>
Pulsed blow type (-X)	<p>*When the external input is on, the solenoid valve turns on and off according to the set frequency and duty ratio. For details, see pages 2 and 3.</p>



Do not perform a megger test between pins.

Note 1: With the power saving type (-L) and PLC drive type (-R), avoid use with switches that can cause chattering. Such switches can also cause incorrect power saving circuit operation.

- Noise may be generated in the area around the coil while the valve is energized. This is due to the properties of power saving circuit and does not indicate malfunction of the valve.
- When using a lead wire for the power supply line of the power saving type (-L) and PLC drive type (-R), use a lead wire that is no more than 1 meter in length. When using a cable, use a cable that is at least 1 meter and no more than 4 meters in length.
- When wiring the power supply line of the power saving type (-L) and PLC drive type (-R), be sure to use a twisted pair cable if the terminal block is relayed. The cable should be a total length of at least 1 meter and no more than 4 meters in length from the power supply.

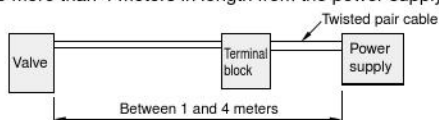

- When wiring the power supply line of the power saving type (-L) and PLC drive type (-R), installing a filter or other intermediate device can cause improper power saving circuit operation.

## No-protection circuit type (-N) LED usage precautions

Using the same power supply to operate no-protection circuit type solenoid valve's LED indicators and coil operation creates the risk of LED damage due to counter electromotive force generated when the coil is off. In this case, provide protection circuit (Diagram 1).

Note: Response times shown in the catalog specifications are values when LEDs are not used.

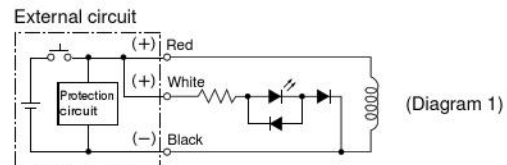

## Pulsed blow type (-X) externally connected circuit

Refer to the figure below (Diagram 2) when wiring to the pulsed blow type.

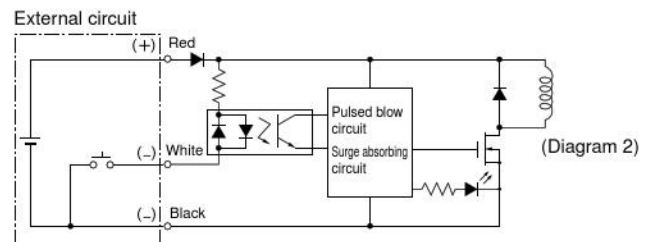

## Power saving circuit current waveforms

The power line waveform for the low energy type (-L) and PLC drive type (-R) with -24 power specifications is shown below.

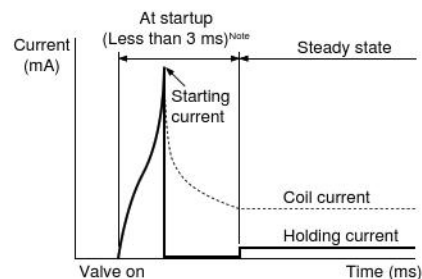

Note: The startup time varies depending on the model.

## Installation



- Installing valves side-by-side or with a manifold will generate large amounts of coil heat. Provide at least 1 mm of space between coils.
- Coils generate heat. Avoid energizing coils without applying air. During use in combination with a nozzle or other type of throttling valve, provide an air flow of at least 5 l/min while the valve is energized.
- Allowing ferromagnetic material to come into contact with the solenoid valve (coil) can cause erratic operation. Keep such materials at least 1 mm away from solenoid valves.

## Restrictions on 4 W power specification type continuous energizing time



In the case of the 4 W power specification type, be sure to use a continuous energizing time that is below the voltage waveform shown below. A longer energizing time results in heat build-up due to coil heat generation, which can lead to damage or burnout. Contact Koganei for details.

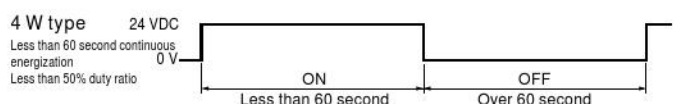

## Pulsed blow type (-X) operation method



When configuring frequency and duty ratio settings using a pulsed blow type, always conduct a safety check of the area of machine operation before supplying air or electricity to the device and before starting operation. The actuator may move unintentionally and may result in damage or personal injury caused by contact with moving parts.

### Setting range of pulsed blow type (-X)

When using a pulsed blow type and configuring frequency and duty ratio settings, there is a range in which settings cannot be configured due to on/off response delay.

Configure frequency and duty ratio settings using the graph of the range where settings can be configured as a guide.

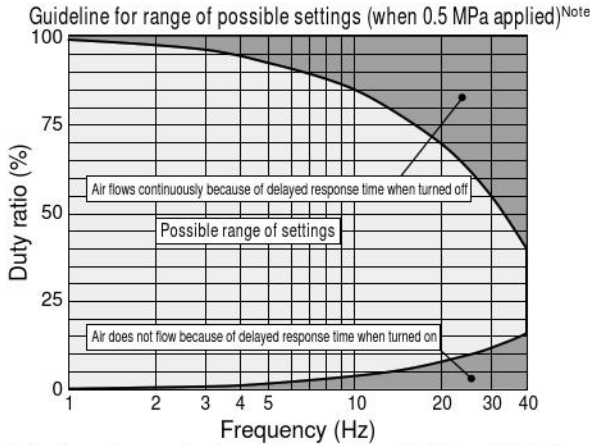

Note: The above two graphs show reference values for K3 and K4 Series types with an ON response time of 4.0 ms and an OFF response time of 15 ms.

### Air consumption guidelines using the pulsed blow type (-X)

The graph below shows the relationship between the frequency and duty ratio, and the air consumption volume due to ON/OFF response delay, assuming an air consumption volume during continuous energizing (100% duty ratio) of 100%, when a pulsed blow type is used and the air consumption volume is controlled. Configure frequency and duty settings using the graph below as a guide.

\*The duty ratio is the ratio of energizing ON time within one cycle (ON and OFF).

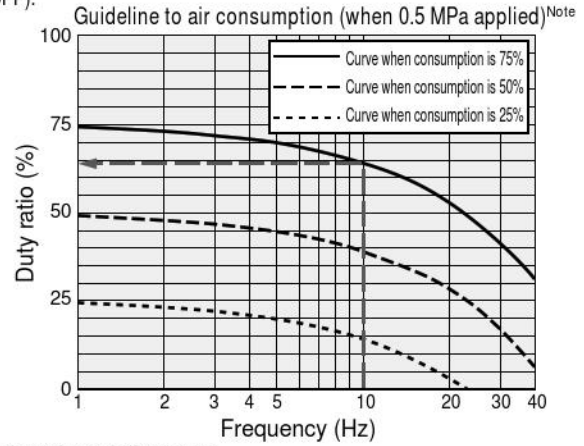

### Explanation of diagrams

A duty ratio of approximately 64% is required when the frequency is 10 Hz and the air consumption volume is 75%.

## Infrared remote control and program specifications

### Remote control program

Item	Manufacturer setting
Manufacturer code (remote control setting)	Toshiba (for analog TV)

### Remote control functions (Recommended remote control unit: Ohm Electric Inc. ORC-02DG)

Function	Buttons	Description of function
Lock release	Press [0/10] <sup>Note 1</sup> four times	Releases infrared receive lock and changes settings. (External input must be OFF to release lock.)
ON/OFF	[Power]	While infrared input is OFF and after releasing lock, valve oscillation can be turned ON or OFF with the remote control.
Settings by value input	[1] to [9], [0/10] <sup>Note 1</sup>	Use these buttons to input values when changing frequency (Hz) and duty ratio (%) settings.
	[11] (Frequency) [12] (Duty ratio)	Press after inputting a value to change the frequency (Hz). Press after inputting a value to change the duty ratio (%). A duty ratio of 100% is continuous energizing.
Settings by variable input	[Channel +/-]	Change the frequency (Hz) in units of 1 (Hz). With key repeat <sup>Note 2</sup> .
	[Volume +/-]	Change the duty ratio (%) in units of 1 (%). With key repeat <sup>Note 3</sup> .
Registration	[Change input]	Registers setting values (frequency (Hz), duty ratio (%)) that have been changed and lock infrared receive. Registering settings causes settings to be saved even if the power supply to the valve is cut off.
Registered value recall	[Mute]	Recalls the most recently registered settings.

Note 1: Though the [0/10] button is used as a [0] button, the marking of the button depends on the remote control being used.

If your remote control does not have a [0] button, the [10] button is used for [0].

2: Holding down a button for more than 0.5 seconds will scroll the frequency value upwards or downwards.

3: Holding down a button for more than 0.5 seconds will scroll the duty ratio value upwards or downwards.

### Valve LED indicators

During valve operation	The valve LED light timing is the same as the oscillation frequency and duty ratio.
During remote control input	When lock is released, aiming the remote control at the valve and operating a button causes the valve LED to light or go out for 0.1 seconds.
During lock release	Valve LED does not light with the first press of [0/10], does not light with the second press of [0/10], does not light with the third press of [0/10], and lights for 0.1 seconds with the fourth press of [0/10].

### Operation precautions

1	When configuring settings, make sure that 24 VDC of power is supplied between the solenoid valve input (+) and GND (-).
2	Make sure that the remote control signal emitter is aimed at the valve when operating remote control buttons. Settings will not be configured if you operate the remote control without aiming at the valve.
3	Another pulsed blow type valve that is near the valve whose settings are being configured can cause interference in the infrared signal during remote control input. To avoid interference, be sure to disconnect the connectors and cut off the power supply of all valves except for the one being configured.
4	Perform remote control input slowly and carefully. Due to delay in the receive process, quick operation may result in incorrect input.
5	Input each value within 10 seconds. Input will be ignored after 10 seconds.
6	If you make a mistake during value input, wait for more than 10 seconds after the last input and then input it again.
7	Remote control input is not supported while a valve is ON by external input (lock release is also not supported).
8	The infrared receive lock function is automatically operational when power is turned on, so release the lock before configuring settings.
9	Executing "Registration" while configuring settings with a remote control automatically executes [Valve stop], performs memory registration, and locks infrared reception.
10	Inputting from an external source while configuring settings with the remote control automatically locks memory registration and infrared reception, and then switches to operation by external input.
11	If the power supply is cut while settings are being configured with a remote control but have not been registered yet, the unregistered settings are discarded and previously registered settings are restored.

## Operational flow with a remote control

※Initial settings when shipped are 10 Hz frequency and 10% duty ratio. Applicable buttons are shown in ⟨ ⟩ brackets.

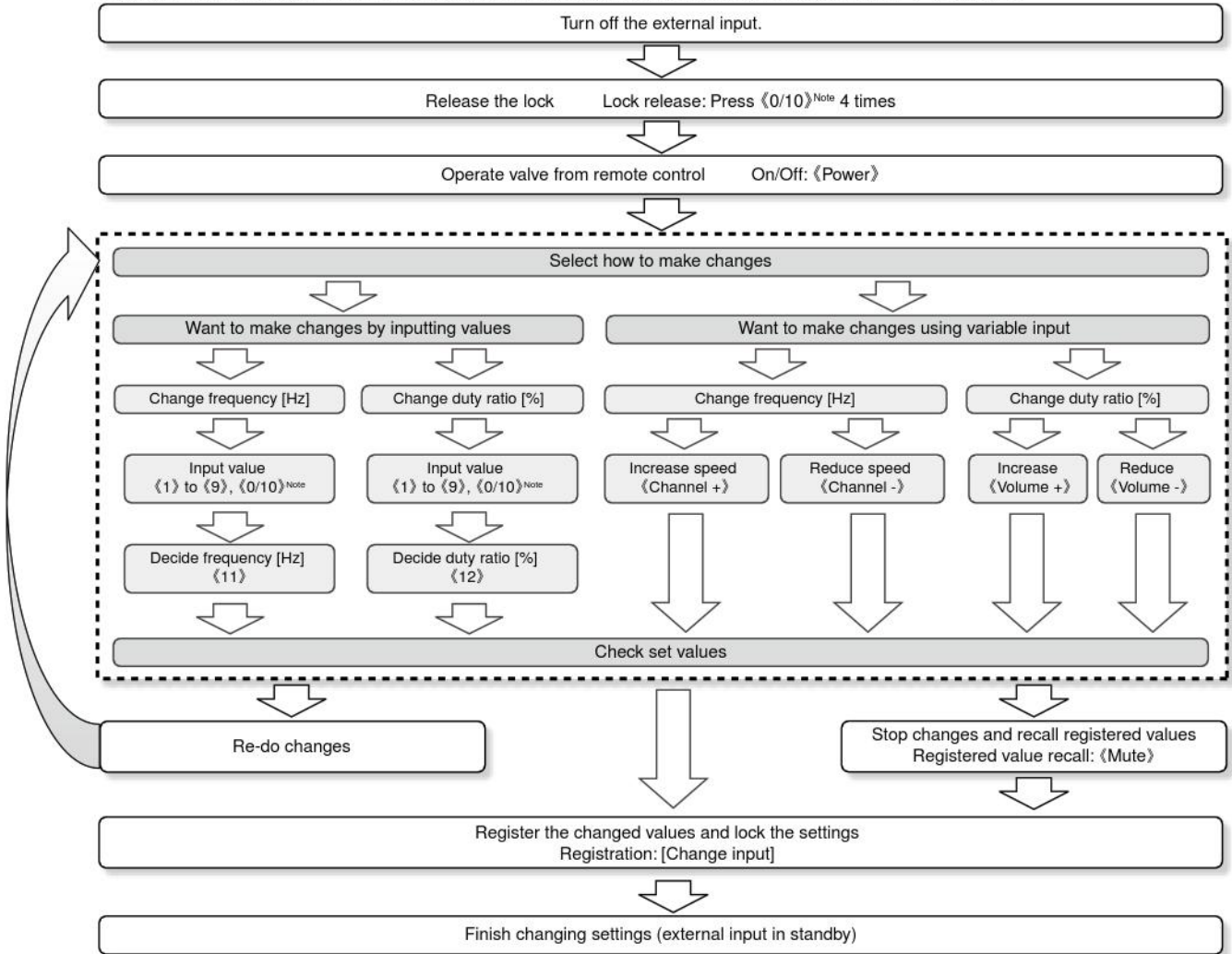

Note: Though the ⟨0/10⟩ button is used as a "0" button, the marking of the button depends on the remote control being used. If your remote control does not have a "0" button, the "10" button is used for "0".

## Recommended remote control buttons

**CAUTION** Make sure that the remote control signal emitter is aimed at the valve when operating remote control buttons.

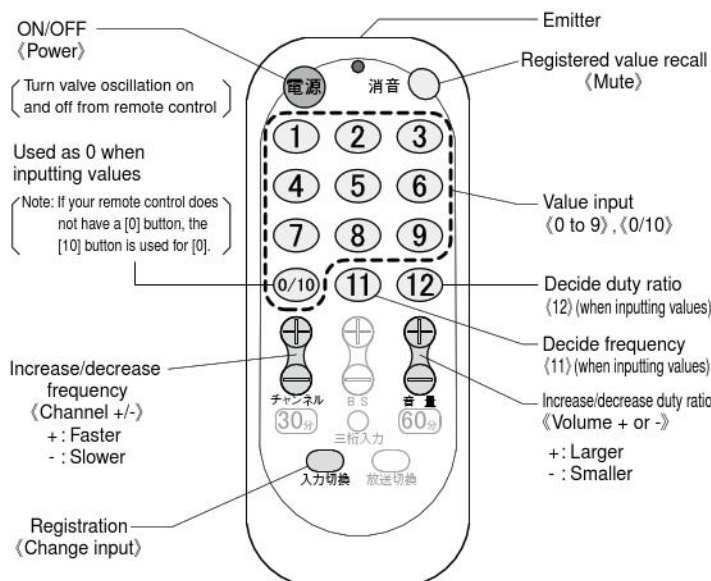

(Recommended remote control unit: Ohm Electric Inc. ORC-02DG)

### To input values to do settings

Example 1: To set 5 Hz as the operating frequency of the valve.  
 5 → 11  
 (Decide frequency)

Example 2: To set 10 Hz as the operating frequency of the valve.  
 1 → 0/10 → 11  
 (Decide frequency)

Example 3: To set the duty ratio of the valve to 25%.  
 2 → 5 → 12  
 (Decide duty ratio)

K3  
K4

## K3 series specifications

### Positive pressure

Item	Basic model		Direct piping				K3-100SF-04 <sup>Note 5</sup>				K3-100SF-24		K3-100HF-24 (Special specifications) <sup>Note 6</sup>	
	Base piping		K3-100SA-02				K3-100SA-04 <sup>Note 5</sup>				K3-100SA-24		K3-100HA-24 (Special specifications) <sup>Note 6</sup>	
	Circuit specifications		-N	-Z	-R	-X	-N	-Z	-R	-X	-L	-R	-L	-R
Media	Air/inert gas													
Operation system	Direct operated													
Number of Ports	3													
Number of Positions	2													
Flow rate characteristics	Sonic conductance C	dm <sup>3</sup> /(s · bar)	0.2				0.2				0.3		0.4	
	Effective area [Cv] <sup>Note 1</sup>	mm <sup>2</sup>	1.0 [0.06]				1.0 [0.06]				1.5 [0.08]		2.0 [0.11]	
Port size	Fitting block: φ4 mm and φ6 mm quick fitting, female thread block: M5×0.8 Air supply block, sub-base: M5×0.8													
Lubrication	Not required													
Operating pressure range	MPa	0 to 0.7										0 to 0.5		
Proof pressure	MPa	1.05												
Response time <sup>Note 2, Note 3</sup>	ON	ms	4.0±1.0				3.0±1.0				1.2±0.5		1.2±0.5	
	OFF	ms	2.0	2.0	2.0	15	2.0	2.0	2.0	15	1.0	1.0	1.0	1.0
Maximum operating frequency <sup>Note 4</sup>	Hz	50	50	50	40	50	50	50	40	100	100	100	100	
Operating temperature range (atmosphere and media)	°C	0 to 50 (non-condensation)												
Shock resistance	m/s <sup>2</sup>	100												
Mounting direction	Any													
Protection structure	IP67 equivalent													
Operating life	Operations	100 million (under Koganei test conditions)										-		
Weight	g	Direct piping type: 52 for piping specifications -J4C, 53 for -J6C, 49 for -M5C (for 300 mm wire length) Base piping type: 64 for piping specifications -A2 (for 300 mm wire length)												

### Vacuum

Item	Basic model		Direct piping				K3-100VF-04 <sup>Note 5</sup>				K3-100VF-24	
	Base piping		K3-100VA-02				K3-100VA-04 <sup>Note 5</sup>				K3-100VA-24	
	Circuit specifications		-N	-Z	-R	-X	-N	-Z	-R	-X	-L	-R
Media	Air/inert gas/vacuum											
Operation system	Direct operated											
Number of Ports	3											
Number of Positions	2											
Flow rate characteristics	Sonic conductance C	dm <sup>3</sup> /(s · bar)	0.2				0.2				0.3	
	Effective area [Cv] <sup>Note 1</sup>	mm <sup>2</sup>	1.0 [0.06]				1.0 [0.06]				1.5 [0.08]	
Port size	Fitting block: φ4 mm and φ6 mm quick fitting, female thread block: M5×0.8 Air supply block, sub-base: M5×0.8											
Lubrication	Not required											
Operating pressure range	MPa	3 (R) port: -100 kPa to 0, 1 (P) port: -100 kPa to 0.7 MPa										
Proof pressure	MPa	1.05										
Response <sup>Note 2, Note 3</sup>	ON	ms	4.0±1.0				3.0±1.0				1.2±0.5	
	OFF	ms	2.0	2.0	2.0	15	2.0	2.0	2.0	15	1.0	1.0
Maximum operating frequency <sup>Note 4</sup>	Hz	50	50	50	40	50	50	50	40	100	100	
Operating temperature range (atmosphere and media)	°C	0 to 50 (non-condensation)										
Shock resistance	m/s <sup>2</sup>	100										
Mounting direction	Any											
Protection structure	IP67 equivalent											
Operating life	Operations	100 million (under Koganei test conditions)										
Weight	g	Direct piping type: 52 for piping specifications -J4C, 53 for -J6C, 49 for -M5C (for 300 mm wire length) Base piping type: 64 for piping specifications -A2 (for 300 mm wire length)										

Note 1: Effective area values are calculated values. They are not measured values.

2: Values when air pressure is 0.5 MPa. Values are for continuous operations, except for after a period of non-operation.

3: No-protection circuit type (-N) response times are values when LEDs are not used.

4: Contact Koganei when you wish to operate a valve in excess of this maximum operating frequency.

5: Continuous energizing time is limited. For details, see page 20.

6: For operating conditions and ordering procedures, you will need to consult with Koganei. Contact your nearest Koganei sales office.

## K4 series specifications

### Positive pressure

Basic model	Direct piping	K4-100SF-02				K4-100SF-04 <sup>Note 5</sup>				K4-100SF-24		K4-100HF-24 (Special specifications) <sup>Note 6</sup>		
	Base piping	K4-100SA-02				K4-100SA-04 <sup>Note 5</sup>				K4-100SA-24		K4-100HA-24 (Special specifications) <sup>Note 6</sup>		
Item	Circuit specifications	-N	-Z	-R	-X	-N	-Z	-R	-X	-L	-R	-L	-R	
Media	Air/inert gas													
Operation system	Direct operated													
Number of Ports	4													
Number of Positions	2													
Flow rate characteristics	Sonic conductance C	0.2				0.2				0.3		0.4		
	Effective area [Cv] <sup>Note 1</sup>	1.0 [0.06]				1.0 [0.06]				1.5 [0.08]		2.0 [0.11]		
Port size	Fitting block: $\phi 4$ mm and $\phi 6$ mm quick fitting, female thread block: M5 $\times$ 0.8 Air supply block, sub-base: M5 $\times$ 0.8													
Lubrication	Not required													
Operating pressure range	MPa	0 to 0.7										0 to 0.5		
Proof pressure	MPa	1.05												
Response time <sup>Note 2, Note 3</sup>	ON	4.0 $\pm$ 1.0				3.0 $\pm$ 1.0				1.2 $\pm$ 0.5		1.2 $\pm$ 0.5		
	OFF	2.0	2.0	2.0	15	2.0	2.0	2.0	10	1.0	1.0	1.0	1.0	
Maximum operating frequency <sup>Note 4</sup>	Hz	50	50	50	40	70	70	70	40	100	100	100	100	
Operating temperature range (atmosphere and media)	°C	0 to 50 (non-condensation)												
Shock resistance	m/s <sup>2</sup>	100												
Mounting direction	Any													
Protection structure	IP67 equivalent											-		
Operating life	Operations	100 million (under Koganei test conditions)												
Weight	g	Direct piping type: 54 for piping specifications -J4F, 57 for -J6F, 49 for -M5F (for 300 mm wire length) Base piping type: 63 for piping specifications -A2 (for 300 mm wire length)												

Note 1: Effective area values are calculated values. They are not measured values.

2: Values when air pressure is 0.5 MPa. Values are for continuous operations, except for after a period of non-operation.

3: No-protection circuit type (-N) response times are values when LEDs are not used.

4: Contact Koganei when you wish to operate a valve in excess of this maximum operating frequency.

5: Continuous energizing time is limited. For details, see page 20.

6: For operating conditions and ordering procedures, you will need to consult with Koganei. Contact your nearest Koganei sales office.

### K3 and K4 series electrical specifications

Item	Circuit specifications		No-protection circuit type -N		Surge absorbing type -Z		Power saving type -L <sup>Note 1</sup>		PLC drive type -R <sup>Note 1</sup>			Pulsed blow type -X <sup>Note 1</sup>		
	Power specifications (Flow rate type)		-02	-04 <sup>Note 3</sup>	-02	-04 <sup>Note 3</sup>	-24		-02	-04 <sup>Note 3</sup>	-24 <sup>Note 2</sup>	-02	-04 <sup>Note 3</sup>	
Rated voltage	24 VDC													
System	DC solenoid (parallel)													
Operating voltage range	V	21.6 to 26.4 (24.0 $\pm$ 10%)												
Power specifications -02, -04	Current value (when rated voltage is applied)	mA	84	167	84	167	—		84	167	—	90	170	
	Power consumption	W	2.0	4.0	2.0	4.0	—		2.0	4.0	—	2.2	4.1	
Power specifications -24	Current value (when rated voltage is applied)	Starting	—		—		1000		—		1000		—	
		Holding	—		—		84		—		84		—	
	Power consumption	Starting	—		—		24		—		24		—	
		Holding	—		—		2		—		2		—	
Vcc current value (standby)	mA	—		—		—		—		—		6 (24 VDC)		
External input	PLC input	Rated voltage	—		—		—		5 to 24 DC $\pm$ 10% <sup>Note 4</sup>			Shorted within valve		
	PLC input	Rated current	—		—		—		23 (24 VDC)			5 (24 VDC)		
	Contact type	NPN open collector												
Allowable circuit leak current	mA	3.5	7	3		3		1		0.25				
LED circuit consumption current (when connected)	mA	4		(as standard)										
Insulation resistance	M $\Omega$	100 or greater												
LED indicator color	Red													
Surge protection	None			Surge absorbing transistor						Flywheel diode				

Note 1: Surge absorbing circuit is provided as standard in the case of circuit specifications -L, -R, and -X.

2: Power saving circuit is built-in in the case of power specifications -24 of circuit specifications -R (PLC drive type).

3: Continuous energizing time is limited. For details, see page 20.

4: If the PLC input voltage is DC 13.2 V or more and the excitation ratio is 50% or more or the continuous energization time is 1 second or more, please contact the nearest external sales office.

## K3 and K4 series flow rate

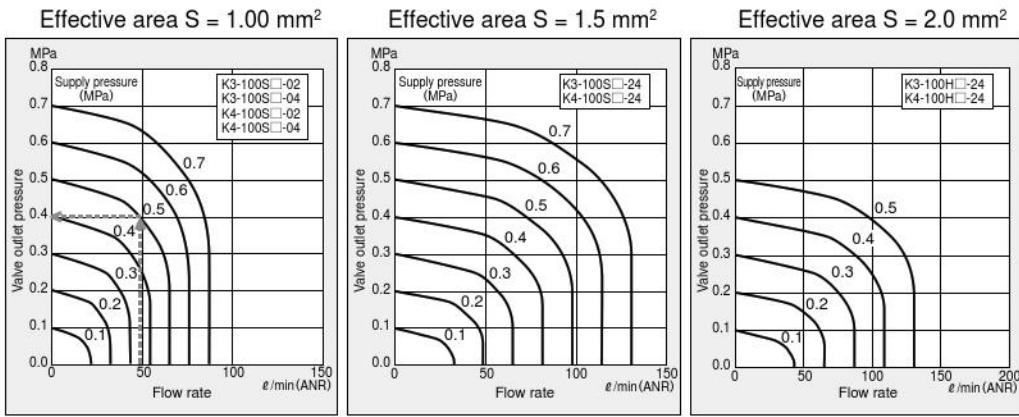

### Explanation of diagrams

At supply pressure of 0.5 MPa, and flow rate of 49  $\ell/\text{min}$  (ANR), valve outlet pressure becomes 0.4 MPa.

## K3 series (vacuum) time of supplying air/exhausting air

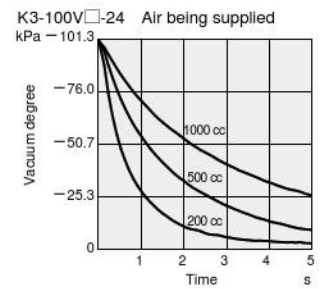
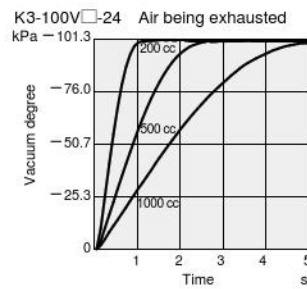
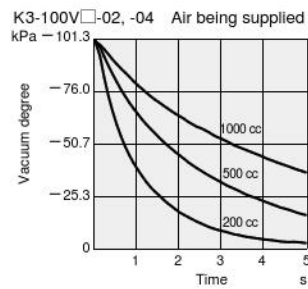
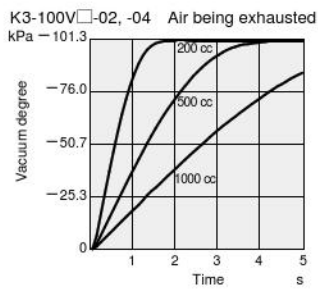
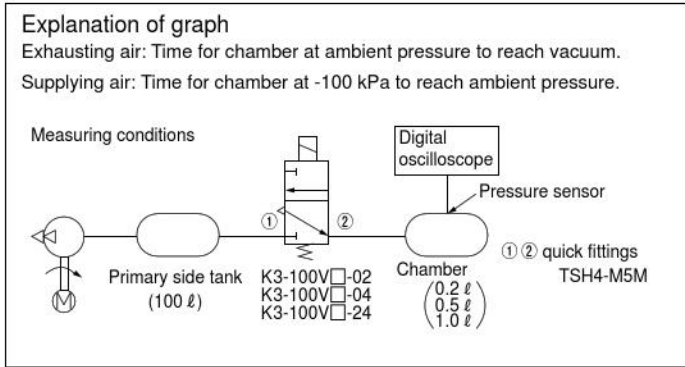

# K3 Series order codes

K3  
K4

**Basic model**  
 K3-100SF: Direct piping, 3-port, standard flow rate type  
 K3-100HF: Direct piping, 3-port, high flow rate type<sup>Note 2</sup>  
 K3-100VF: Direct piping, 3-port, vacuum & standard flow rate type  
 K3-100SA: Base piping, 3-port, standard flow rate type  
 K3-100HA: Base piping, 3-port, high flow rate type<sup>Note 2</sup>  
 K3-100VA: Base piping, 3-port, vacuum & standard flow rate type

**Wiring specifications**  
 S0: IP67 S-type plug connector, 300 mm lead wire  
 S1: IP67 S-type plug connector, 1000 mm lead wire  
 S3: IP67 S-type plug connector, 3000 mm lead wire<sup>Note</sup>  
 Note: Cable length is 3000 mm in the case of power saving type -L and PLC drive type -R.  
 SN: IP67 S-type plug connector, no connector  
 L0: IP67 L-type plug connector, 300 mm lead wire  
 L1: IP67 L-type plug connector, 1000 mm lead wire  
 L3: IP67 L-type plug connector, 3000 mm lead wire<sup>Note</sup>  
 Note: Cable length is 3000 mm in the case of power saving type -L and PLC drive type -R.  
 LN: IP67 L-type plug connector, no connector

**Power specifications**  
 -02: 2 W  
 -04: 4 W<sup>Note 1</sup>  
 -24: 24 W (with power saving circuit)

**Circuit specifications**  
 -N: No-protection circuit type (3-wire)  
 (Without surge absorbing circuit)  
 -Z: Surge absorbing type (2-wire)  
 (With surge absorbing circuit)  
 -L: Power saving type (2-wire)  
 (With surge absorbing circuit)  
 -R: PLC drive type (4-wire)  
 (With surge absorbing circuit)  
 -X: Pulsed blow type (3-wire)  
 (With surge absorbing circuit)

**Piping specifications**  
 For direct piping  
 Blank: No input/output block<sup>Note 4</sup>  
 -J4A: No air supply block, with φ4 fitting block (NC)  
 -J4B: No air supply block, with φ4 fitting block (NO)  
 -J4C: With air supply block, with φ4 fitting block (NC)  
 -J4D: With air supply block, with φ4 fitting block (NO)  
 -J6A: No air supply block, with φ6 fitting block (NC)  
 -J6B: No air supply block, with φ6 fitting block (NO)  
 -J6C: With air supply block, with φ6 fitting block (NC)  
 -J6D: With air supply block, with φ6 fitting block (NO)  
 -M5A: No air supply block, with M5 female thread block (NC)  
 -M5B: No air supply block, with M5 female thread block (NO)  
 -M5C: With air supply block, with M5 female thread block (NC)  
 -M5D: With air supply block, with M5 female thread block (NO)  
 For base piping  
 Blank: No sub-base, no plate<sup>Note 4</sup>  
 -A1: No sub-base, with plate  
 -A2: With sub-base, with plate<sup>Note 3</sup>

	Basic model	Power specifications	Circuit specifications	Wiring specifications	Piping specifications	Voltage
Direct piping	K3-100SF K3-100VF	-02 -04 <sup>Note 1</sup>	-N -Z -R  -X	S0 L0 S1 L1 S3 L3 SN LN  S0 S3 S1 SN	Blank <sup>Note 4</sup> -J4A -J4B -J4C -J4D -J6A -J6B -J6C -J6D -M5A -M5B -M5C -M5D	24 VDC
	K3-100SF K3-100HF <sup>Note 2</sup> K3-100VF	-24	-L -R	S0 L0 S1 L1 S3 L3 SN LN		
Base piping	K3-100SA K3-100VA	-02 -04 <sup>Note 1</sup>	-N -Z -R  -X	S0 L0 S1 L1 S3 L3 SN LN  S0 S3 S1 SN	Blank <sup>Note 4</sup> -A1 -A2 <sup>Note 3</sup>	24 VDC
	K3-100SA K3-100HA <sup>Note 2</sup> K3-100VA	-24	-L -R	S0 L0 S1 L1 S3 L3 SN LN		

Note 1: Continuous energizing time is limited. For details, see page 20.  
 Note 2: K3-100HF and K3-100HA are special specification products. For operating conditions and ordering procedures, you will need to consult with Koganei. Contact your nearest Koganei sales office.  
 Note 3: A plug is included with the -A2 (sub-base included), so the plug can be used to select the NC/NO setting. For details, see page 10.  
 Note 4: Cannot be used if wiring specifications are blank.  
 Be sure to mount an input/output block (direct piping), or sub-base plate (base piping).

## K3 Series additional parts order codes

### Mounting bracket



K310-21: Mounting bracket  
(with mounting screws), 1 set

### Air supply block



K310-MP: Air supply block  
(no mounting screws), 1 set

### φ4 fitting block for 3-port



K310-J4A: φ4 fitting block for 3-port  
(with gasket, mounting screws), 1 set

### φ6 fitting block for 3-port



K310-J6A: φ6 fitting block for 3-port  
(with gasket, mounting screws), 1 set

### Female thread block for 3-port



K310-M5A: Female thread block for 3-port  
(with gasket, mounting screws), 1 set

### Sub-base



K310-25: Sub-base (no mounting screws), 1 set

### Plate



K310-P: (with gasket, mounting screws), 1 set

### Block-off plate



K310-BP: Block-off plate  
(with gasket, mounting screws), 1 set

### Connector, lead wire type



K210-P20: IP67 plug connector, lead wire (2-wire) length: 300 mm  
K210-P21: IP67 plug connector, lead wire (2-wire) length: 1000 mm  
K210-P23: IP67 plug connector, lead wire (2-wire) length: 3000 mm<sup>Note 1</sup>  
Note 1: Use a cable type for a 3000 mm length for the power saving type (-L).



K210-P30: IP67 plug connector, lead wire (3-wire) length: 300 mm  
K210-P31: IP67 plug connector, lead wire (3-wire) length: 1000 mm  
K210-P33: IP67 plug connector, lead wire (3-wire) length: 3000 mm



K210-P40: IP67 plug connector, lead wire (4-wire) length: 300 mm  
K210-P41: IP67 plug connector, lead wire (4-wire) length: 1000 mm

### Connector, cable type



K210-C31: IP67 plug connector, cable (3-wire) length: 1000 mm<sup>Note 2</sup>  
K210-C33: IP67 plug connector, cable (3-wire) length: 3000 mm<sup>Note 2</sup>  
K210-C35: IP67 plug connector, cable (3-wire) length: 5000 mm<sup>Note 2</sup>  
Note 2: In the case of 2-wire specifications (-L, -Z), cut the white lead wire to use.



K210-C41: IP67 plug connector, cable (4-wire) length: 1000 mm  
K210-C43: IP67 plug connector, cable (4-wire) length: 3000 mm

# K4 Series order codes

K3  
K4

**Basic model**

K4-100SF: Direct piping, 4-port, standard flow rate type  
 K4-100HF: Direct piping, 4-port, high flow rate type<sup>Note 2</sup>  
 K4-100SA: Base piping, 4-port, standard flow rate type  
 K4-100HA: Base piping, 4-port, high flow rate type<sup>Note 2</sup>

**Wiring specifications**

S0: IP67 S-type plug connector, 300 mm lead wire  
 S1: IP67 S-type plug connector, 1000 mm lead wire  
 S3: IP67 S-type plug connector, 3000 mm lead wire<sup>Note</sup>  
 Note: Cable length is 3000 mm in the case of power saving type -L and PLC drive type -R.  
 SN: IP67 S-type plug connector, no connector  
 L0: IP67 L-type plug connector, 300 mm lead wire  
 L1: IP67 L-type plug connector, 1000 mm lead wire  
 L3: IP67 L-type plug connector, 3000 mm lead wire<sup>Note</sup>  
 Note: Cable length is 3000 mm in the case of power saving type -L and PLC drive type -R.  
 LN: IP67 L-type plug connector, no connector

**Power specifications**

-02: 2 W  
 -04: 4 W<sup>Note 1</sup>  
 -24: 24 W (with power saving circuit)

**Circuit specifications**

-N: No-protection circuit type (3-wire)  
 (Without surge absorbing circuit)  
 -Z: Surge absorbing type (2-wire)  
 (With surge absorbing circuit)  
 -L: Power saving type (2-wire)  
 (With surge absorbing circuit)  
 -R: PLC drive type (4-wire)  
 (With surge absorbing circuit)  
 -X: Pulsed blow type (3-wire)  
 (With surge absorbing circuit)

**Piping specifications**

For direct piping  
 Blank: No input/output block<sup>Note 3</sup>  
 -J4E: No air supply block, with φ4 fitting block  
 -J4F: With air supply block, with φ4 fitting block  
 -J6E: No air supply block, with φ6 fitting block  
 -J6F: With air supply block, with φ6 fitting block  
 -M5E: No air supply block, with M5 female thread block  
 -M5F: With air supply block, with M5 female thread block  
 For base piping  
 Blank: No sub-base, no plate<sup>Note 3</sup>  
 -A1: No sub-base, with plate  
 -A2: With sub-base, with plate

	Basic model	Power specifications	Circuit specifications	Wiring specifications	Piping specifications	Voltage
Direct piping	K4-100SF	-02 -04 <sup>Note 1</sup>	-N -Z -R	S0 L0 S1 L1 S3 L3 SN LN	Blank <sup>Note 3</sup> -J4E -J4F -J6E -J6F -M5E -M5F	24 VDC
	K4-100SF K4-100HF <sup>Note 2</sup>	-24	-X	S0 S3 S1 SN		
Base piping	K4-100SA	-02 -04 <sup>Note 1</sup>	-N -Z -R	S0 L0 S1 L1 S3 L3 SN LN	Blank <sup>Note 3</sup> -A1 -A2	24 VDC
	K4-100SA K4-100HA <sup>Note 2</sup>	-24	-X	S0 S3 S1 SN		
	K4-100SA K4-100HA <sup>Note 2</sup>	-24	-L -R	S0 L0 S1 L1 S3 L3 SN LN		

Note 1: Continuous energizing time is limited. For details, see page 20.

2: K4-100HF and K4-100HA are special specification products. For operating conditions and ordering procedures, you will need to consult with Koganei. Contact your nearest Koganei sales office.

3: Cannot be used if wiring specifications are blank.

Be sure to mount an input/output block (direct piping), or sub-base plate (base piping).

# K4 Series additional parts order codes

## Mounting bracket



K310-21: Mounting bracket  
(with mounting screws), 1 set

## Air supply block



K310-MP: Air supply block  
(no mounting screws), 1 set

## φ4 fitting block for 4-port



K410-J4E: φ4 fitting block for 4-port  
(with gasket, mounting screws), 1 set

## φ6 fitting block for 4-port



K410-J6E: φ6 fitting block for 4-port  
(with gasket, mounting screws), 1 set

## Female thread block for 4-port



K410-M5E: Female thread block for 4-port  
(with gasket, mounting screws), 1 set

## Sub-base

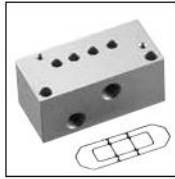

K310-25: Sub-base  
(no mounting screws), 1 set

## Plate



K310-P: (with gasket, mounting screws), 1 set

## Block-off plate



K310-BP: Block-off plate  
(with gasket, mounting screws), 1 set

## Connector, lead wire type



K210-P20: IP67 plug connector, lead wire (2-wire) length: 300 mm  
K210-P21: IP67 plug connector, lead wire (2-wire) length: 1000 mm  
K210-P23: IP67 plug connector, lead wire (2-wire) length: 3000 mm<sup>Note 1</sup>  
Note 1: Use a cable type for a 3000 mm length with the power saving type (-L).



K210-P30: IP67 plug connector, lead wire (3-wire) length: 300 mm  
K210-P31: IP67 plug connector, lead wire (3-wire) length: 1000 mm  
K210-P33: IP67 plug connector, lead wire (3-wire) length: 3000 mm



K210-P40: IP67 plug connector, lead wire (4-wire) length: 300 mm  
K210-P41: IP67 plug connector, lead wire (4-wire) length: 1000 mm

## Connector, cable type



K210-C31: IP67 plug connector, cable (3-wire) length: 1000 mm<sup>Note 2</sup>  
K210-C33: IP67 plug connector, cable (3-wire) length: 3000 mm<sup>Note 2</sup>  
K210-C35: IP67 plug connector, cable (3-wire) length: 5000 mm<sup>Note 2</sup>  
Note 2: In the case of 2-wire specifications (-L, -Z), cut the white lead wire to use.



K210-C41: IP67 plug connector, cable (4-wire) length: 1000 mm  
K210-C43: IP67 plug connector, cable (4-wire) length: 3000 mm

# K3 series dimensions (mm)

## K3-100□F-□-□S0-J□C (direct piping type)

With air supply block, with fitting block (NC),  
S type plug connector

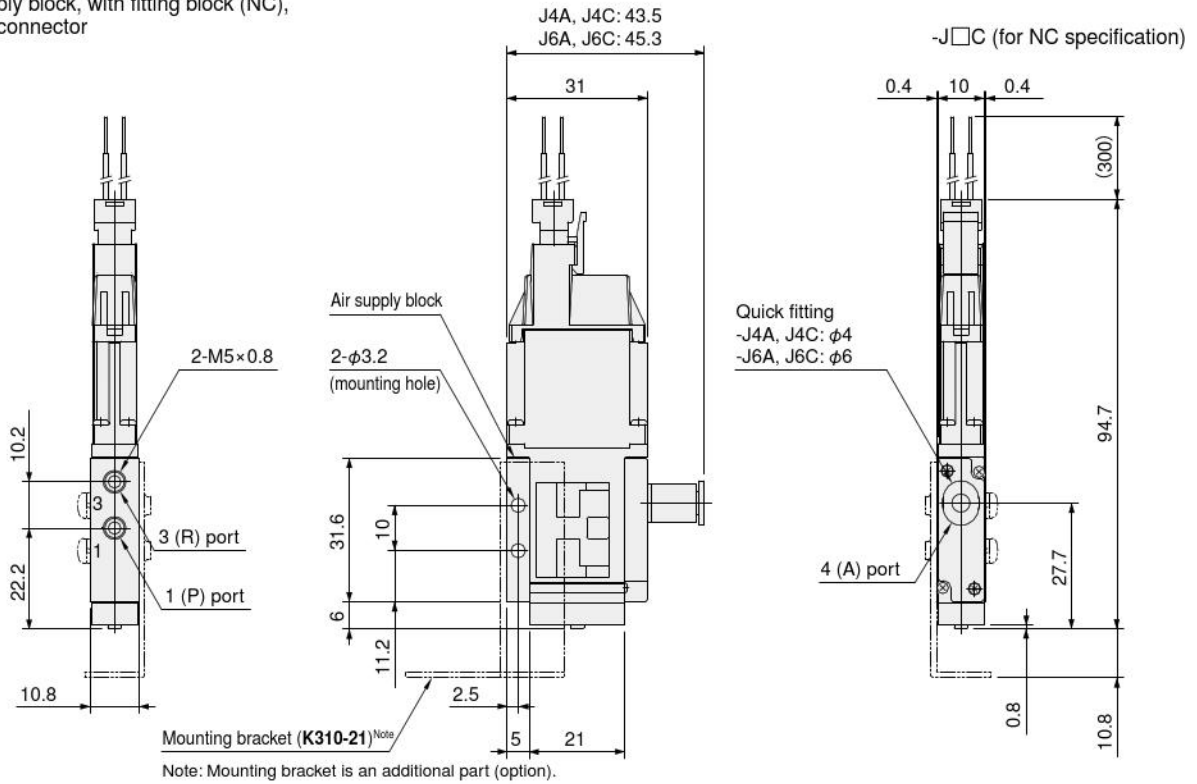

-J□D (for NO specification)

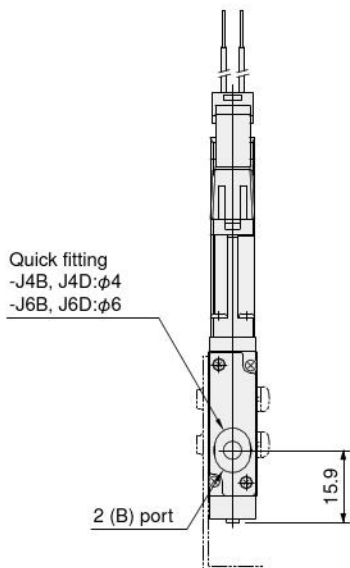

L-type plug connector

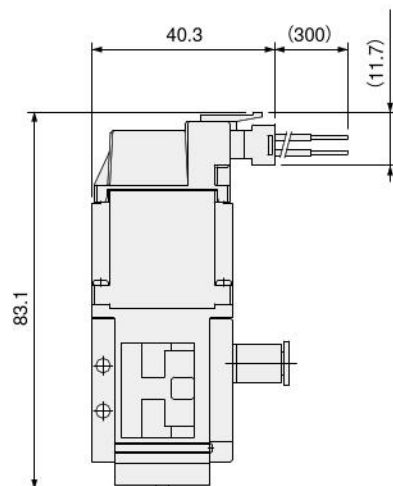

K3  
K4

# K3 series dimensions (mm)

## K3-100□F-□-□S0-M5C (direct piping type)

With air supply block, with female thread block (NC),  
S-type plug connector

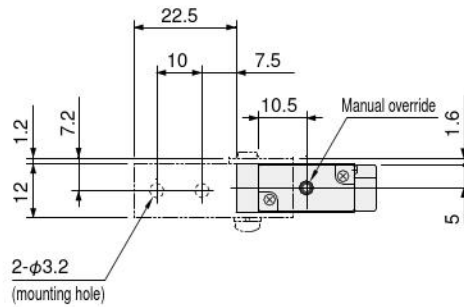
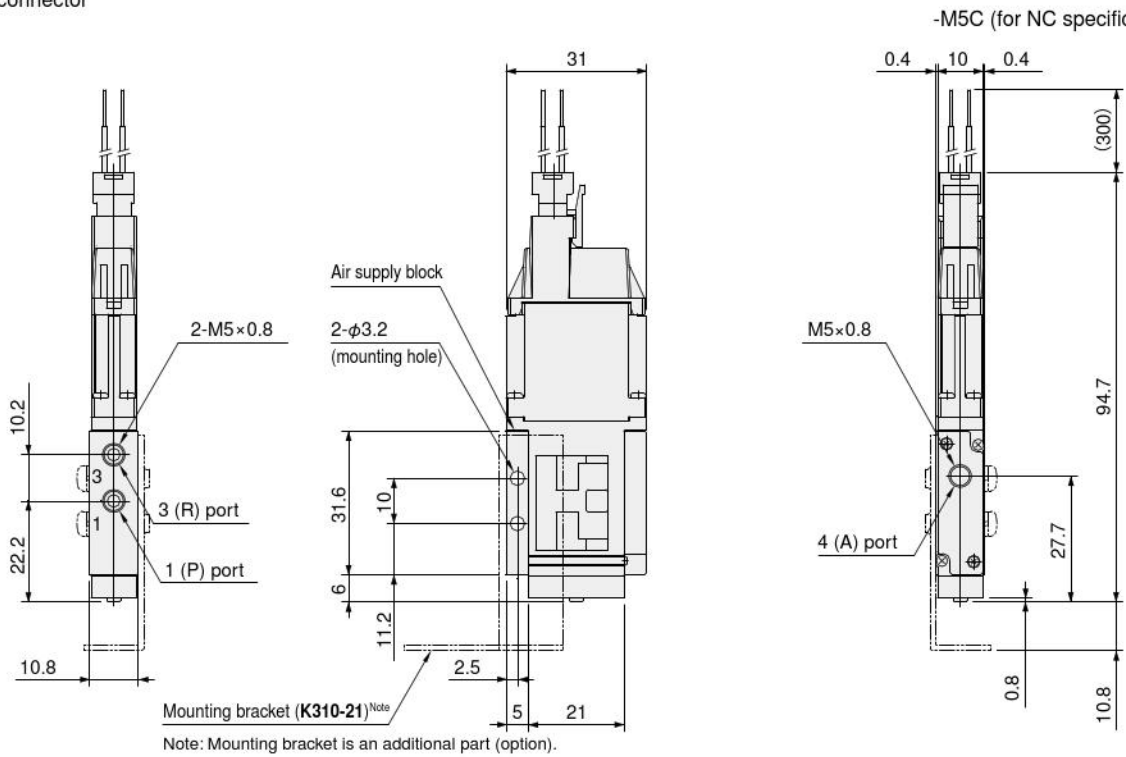

-M5D (for NO specifications)

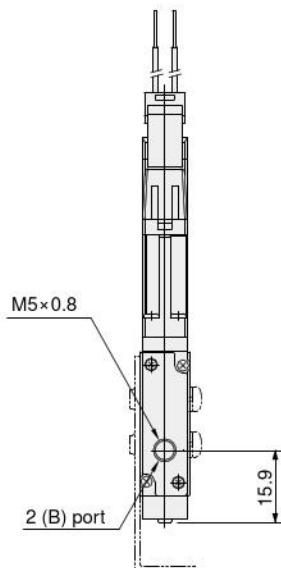

L-type plug connector

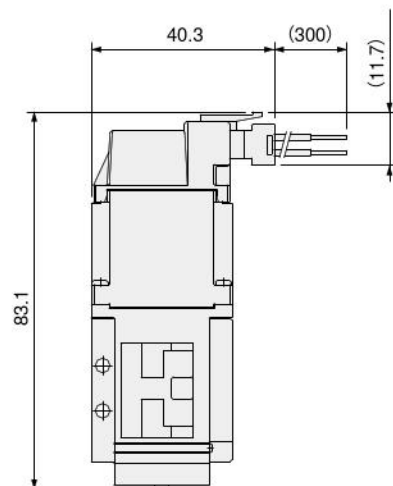

K3 series dimensions (mm)

K3-100□A-□-□S0-A2 (base piping type)

With sub-base,  
S-type plug connector

K3  
K4

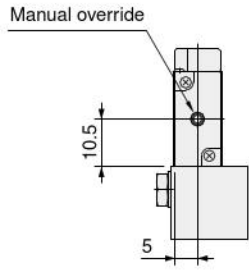
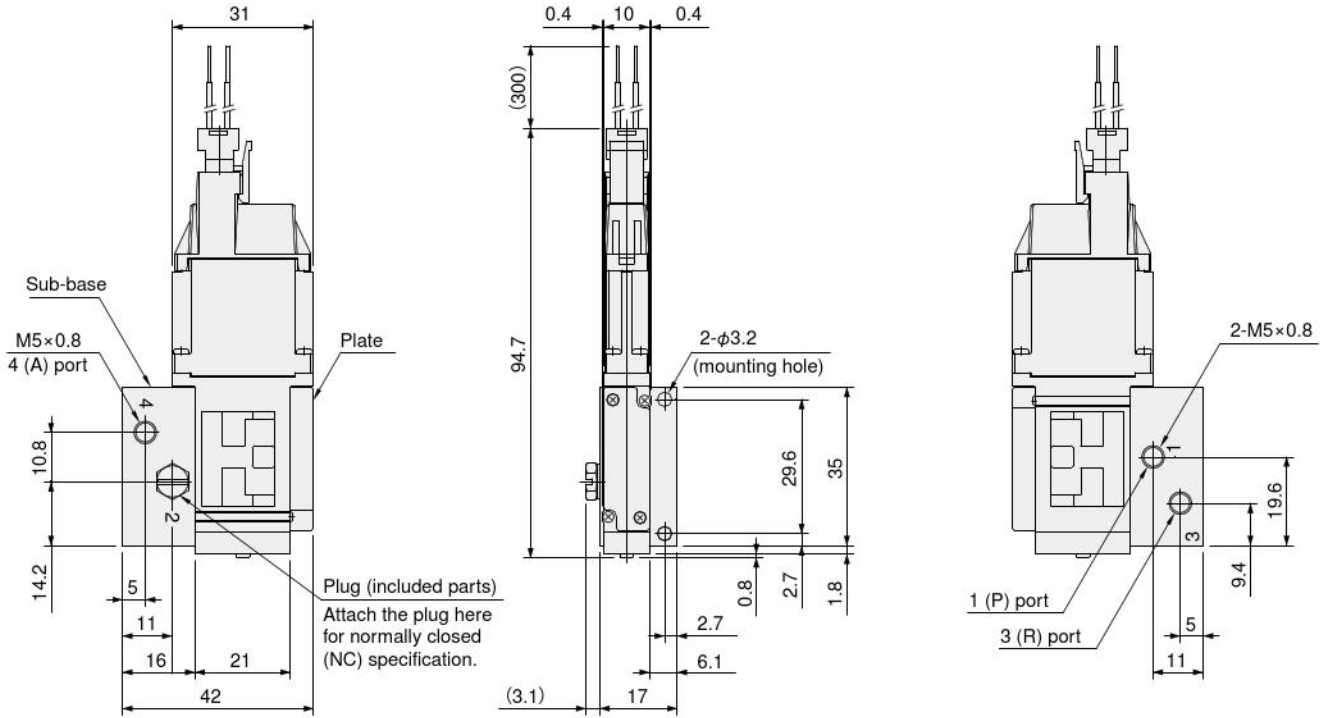

When NO specification are used

L-type plug connector

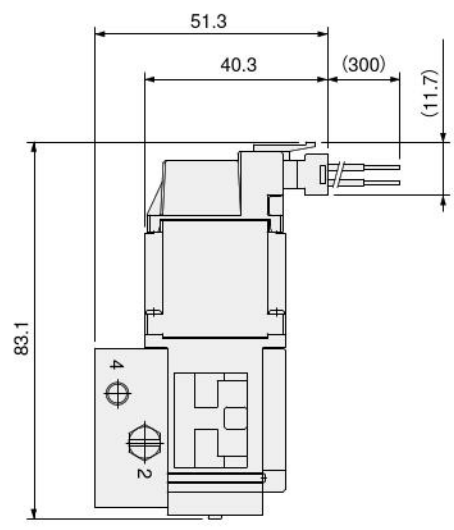
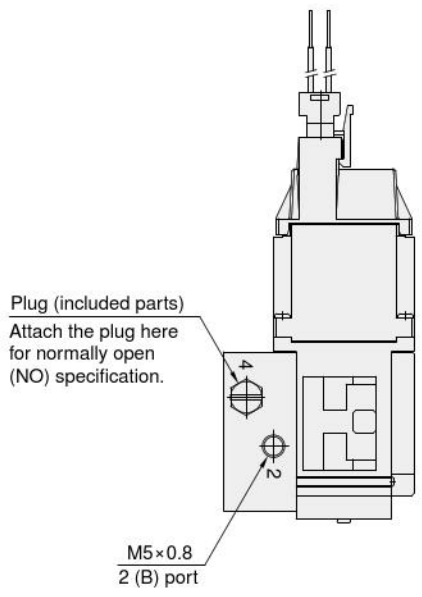

# K3 series dimensions (mm)

## K3-100□F (direct piping) manifold installation dimensions

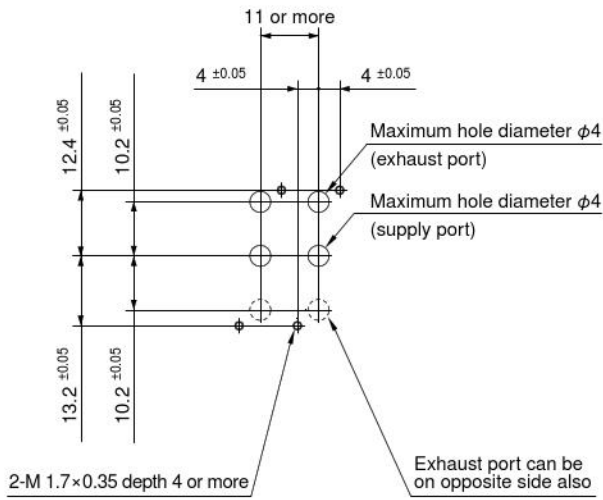

Select a model from the following to mount on the manifold.

- K3-100□F-□-□-J4A DC24V
- K3-100□F-□-□-J4B DC24V
- K3-100□F-□-□-J6A DC24V
- K3-100□F-□-□-J6B DC24V
- K3-100□F-□-□-M5A DC24V
- K3-100□F-□-□-M5B DC24V

Note 1: Be careful not to drop the gasket during mounting.

2: 11 mm minimum pitch for valve installation when mounted on manifold.

## K3-100□A (base piping) manifold installation dimensions

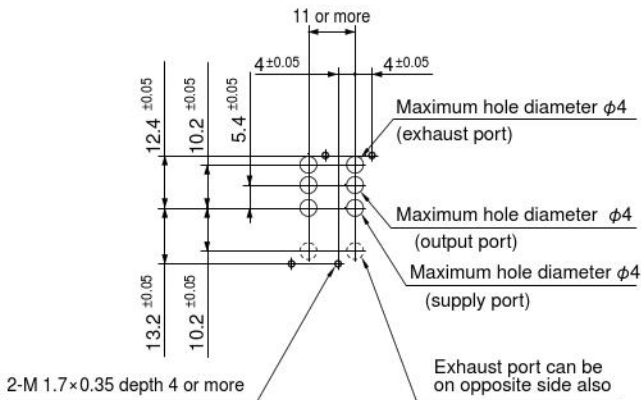

K3-100□A: For NC specification

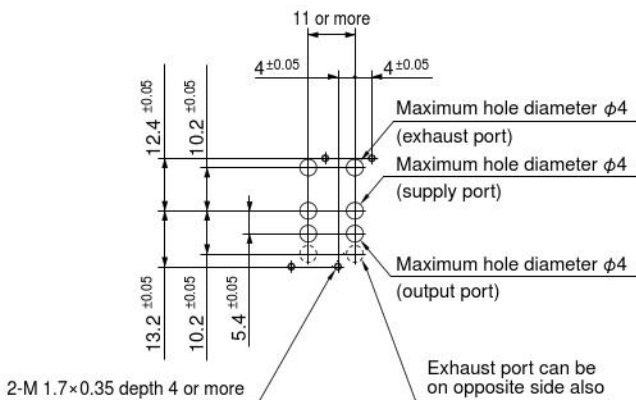

K3-100□A: For NO specification

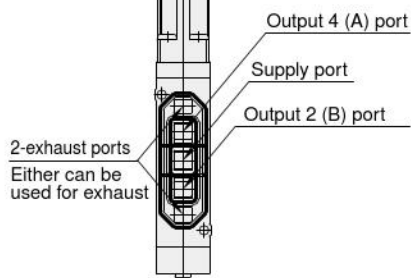

Select a model from the following to mount on the manifold.

- K3-100□A-□-□-A1 DC24V

Note 1: Be careful not to drop the gasket during mounting.

2: 11 mm minimum pitch for valve installation when mounted on manifold.

# K4 series dimensions (mm)

## K4-100□F-□-□S0-J□F (direct piping type)

With air supply block,  
with fitting block, S-type plug connector

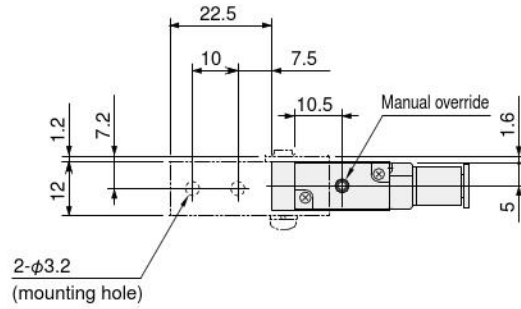
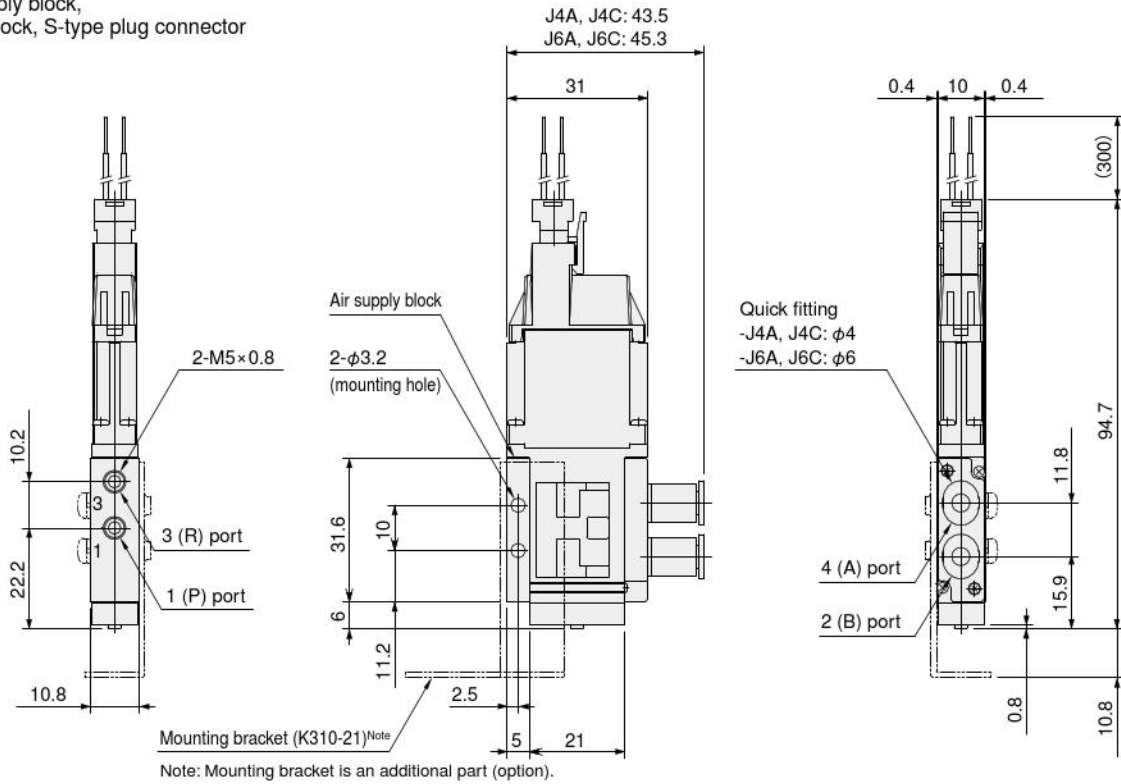

L-type plug connector

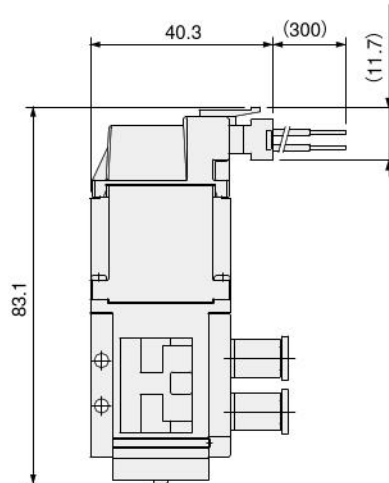

K3  
K4

# K4 series dimensions (mm)

## K4-100□F-□-□S0-M5F (direct piping type)

With air supply block,  
with female thread block, S-type plug connector

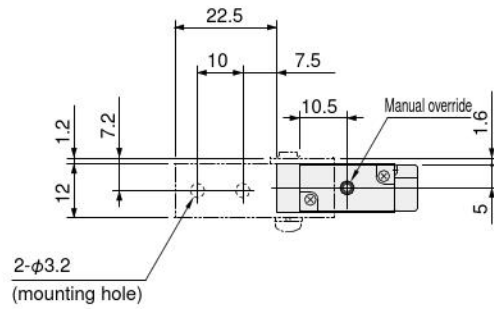
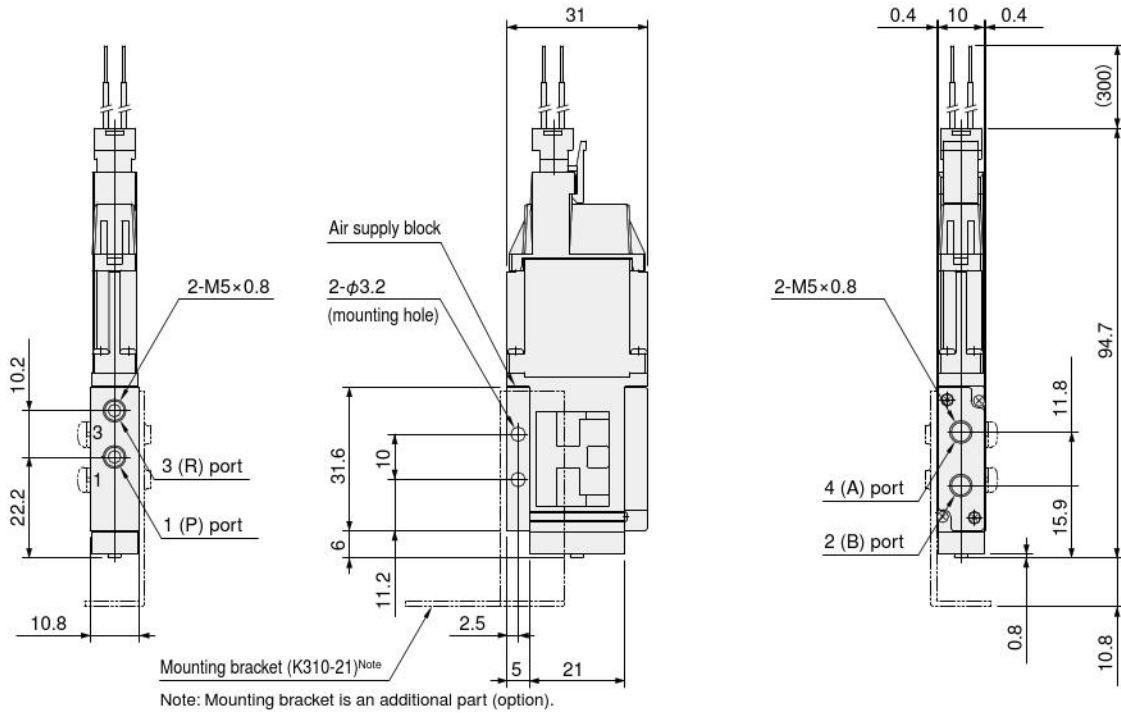

L-type plug connector

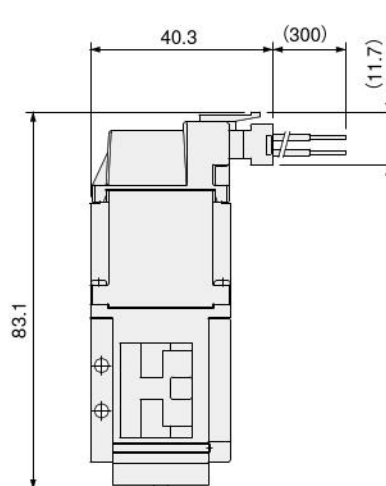

# K4 series dimensions (mm)

## K4-100□A-□-□S0-A2 (base piping type)

With sub-base,  
S-type plug connector

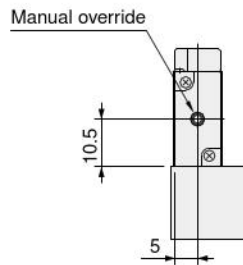
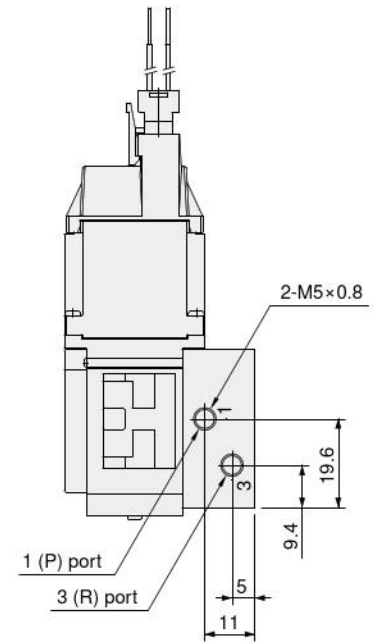
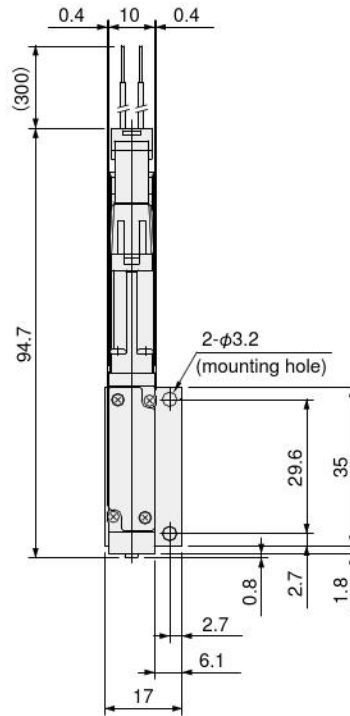
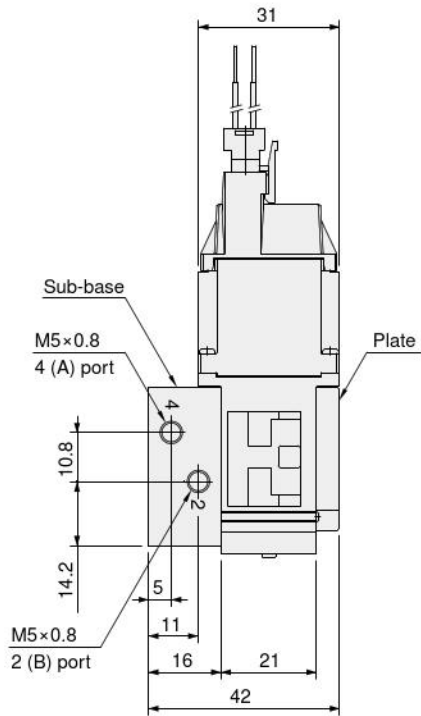

L-type plug connector

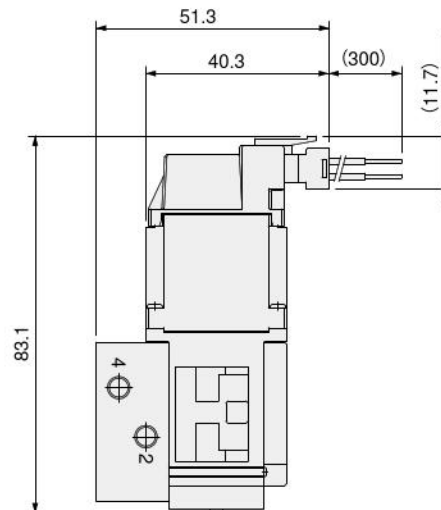

K3  
K4

## K4 series dimensions (mm)

### K4-100□F (direct piping) manifold installation dimensions

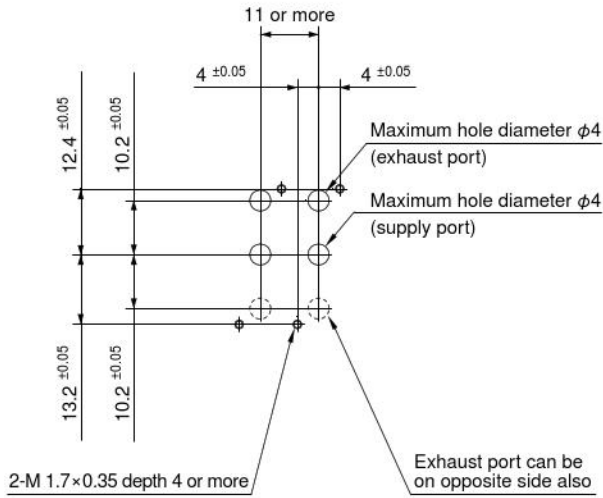

Select a model from the following to mount on the manifold.

- K4-100□F-□-□-J4E DC24V
- K4-100□F-□-□-J6E DC24V
- K4-100□F-□-□-M5E DC24V

Note 1: Be careful not to drop the gasket during mounting.

2: 11 mm minimum pitch for valve installation when mounted on manifold.

### K4-100□A (base piping) manifold installation dimensions

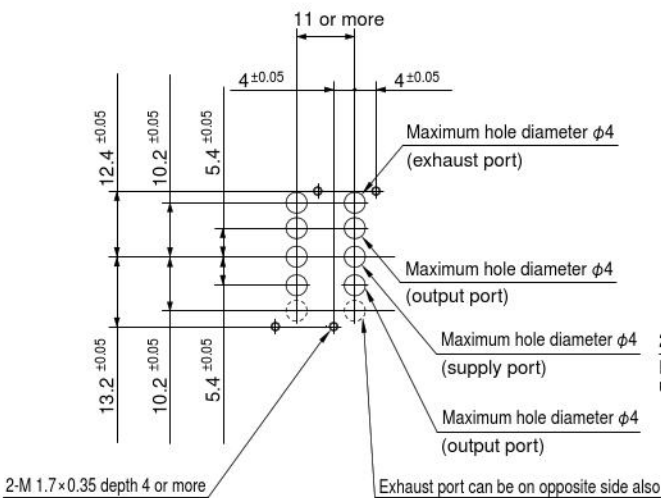

Select a model from the following to mount on the manifold.

K4-100□A-□-□-A1 DC24V

Note 1: Be careful not to drop the gasket during mounting.

2: 11 mm minimum pitch for valve installation when mounted on manifold.

# Limited Warranty

KOGANEI CORP. warrants its products to be free from defects in material and workmanship subject to the following provisions.

**Warranty Period** The warranty period is 180 days from the date of delivery.

**Koganei Responsibility** If a defect in material or workmanship is found during the warranty period, KOGANEI CORP. will replace any part proved defective under normal use free of charge and will provide the service necessary to replace such a part.

**Limitations**

- This warranty is in lieu of all other warranties, expressed or implied, and is limited to the original cost of the product and shall not include any transportation fee, the cost of installation or any liability for direct, indirect or consequential damage or delay resulting from the defects.

- KOGANEI CORP. shall in no way be liable or responsible for injuries or damage to persons or property arising out of the use or operation of the manufacturer's product.

- This warranty shall be void if the engineered safety devices are removed, made inoperative or not periodically checked for proper functioning.

- Any operation beyond the rated capacity, any improper use or application, or any improper installation of the product, or any substitution upon it with parts not furnished or approved by KOGANEI CORP., shall void this warranty.

- This warranty covers only such items supplied by KOGANEI CORP. The products of other manufacturers are covered only by such warranties made by those original manufacturers, even though such items may have been included as the components.

The specifications are subject to change without notice.

K3  
K4

## Attention users of the old type K2 Series!

### Protection structure

Though the old type K2 Series was equivalent to IP65, note that the protection structure is now IP67 equivalent.

URL <http://www.koganei.co.jp>

E-mail: [overseas@koganei.co.jp](mailto:overseas@koganei.co.jp)



## **KOGANEI CORPORATION**

### **OVERSEAS DEPARTMENT**

3-11-28, Midori-cho, Koganei City, Tokyo 184-8533, Japan  
Tel: 81-42-383-7271 Fax: 81-42-383-7276

### **KOGANEI INTERNATIONAL AMERICA, INC.**

39300 Civic Center Dr., Suite 280, Fremont, CA 94538, U.S.A.  
Tel: 1-510-744-1626 Fax: 1-510-744-1676

### **SHANGHAI KOGANEI INTERNATIONAL TRADING CORPORATION**

Room 2606-2607, Tongda Venture Building No.1, Lane 600, Tianshan Road,  
Shanghai, 200051, China  
Tel: 86-21-6145-7313 Fax: 86-21-6145-7323

### **KOGANEI KOREA CO., LTD.**

KT&G Cosmo Bldg., 3F, 40-13, Maesanno 2-ga, Paldal-gu, Suwon-si, Gyeonggi-do,  
442-847, Korea  
Tel: 82-31-246-0414 Fax: 82-31-246-0415

### **KOGANEI-PORNCHAI CO., LTD.**

89/174 Moo 3, Vibhavadee Rangsit Road, Talad Bangkhen, Laksi, Bangkok,  
10210, Thailand  
Tel: 66-2551-4025 Fax: 66-2551-4015

### **KOGANEI ASIA PTE. LTD.**

12 Arumugam road #03-12, Lion Building B, 409958, Singapore  
Tel: 65-6293-4512 Fax: 65-6293-4513