

# JIG CYLINDERS JC SERIES CONTENTS

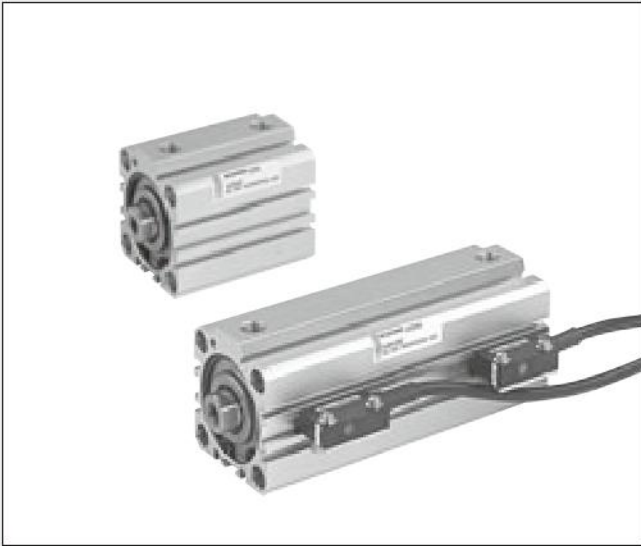

Features, Introductions	211
Handling Instructions and Precautions	213
Maximum Kinetic Energy	214
Spring Return Force	215
Cylinder Thrust	216
Standard Cylinders	
Double Acting Type, Single Acting Push Type, Single Acting Pull Type	
Specifications	217
Order Codes	218
Inner Construction and Major Parts	220
Dimensions	221
Double Rod Cylinders Double Acting Type	
Specifications	237
Order Codes	238
Inner Construction and Major Parts	239
Dimensions	240
Mounting Screws for Jig Cylinders	245
Sensor Switches	246
Strong Magnetic Field Resistant Sensor Switch	249

# JIG CYLINDERS JC SERIES

The New Jig Cylinder is now available in conformity with

**JIS B 8368** mounting dimension standards!

## Increased Durability

The scraper uses a one-piece rod seal, to prevent durability from decreasing due to dust intrusion. (from  $\phi$  40 [1.575in.] to  $\phi$  100 [3.940in.] only)

## Optimum for Compact Devices!

Exhibits performance for clamping, pushing or lifting workpieces, and space-saving with its compact square body.

## Standard Cylinder is compatible with Non-ion Specification

Avoidance of copper materials as standard specifications allows application in cathode-ray tube (CRT) and other similar manufacturing lines. (No filter plug supplied for the single acting type  $\phi$  50 [1.969in.] )

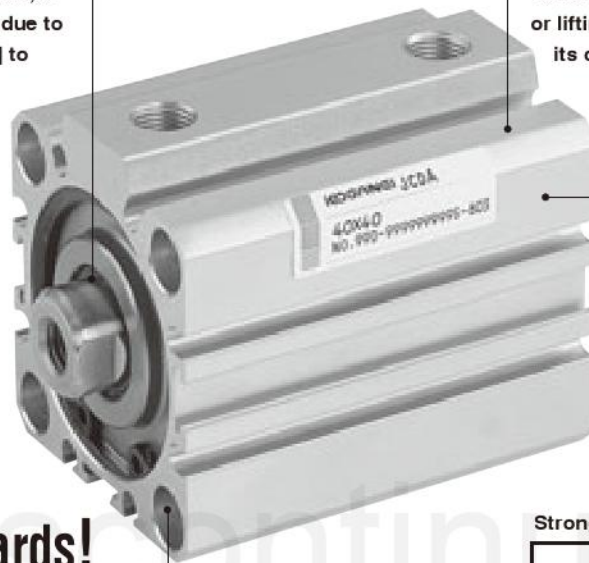

## Meets JIS Standards!

Now conforms to the JIS "1PS Cylinder" standards for mounting dimension. Offers flexible compatibility for actuator mounting standardization requirements in the automotive and machine tool industries, etc.

## Strong magnetic field resistant sensor switch



## Two Types of Sensor Switches Available

Select from 2 types of sensor switches, the ZE type sensor switch embedded in the body, or the ZD type sensor switch for strong magnetic field resistance to prevent erratic operation under harsh operating conditions ( $\phi$  20 [0.787in.] and  $\phi$  25 [0.984in.] offer ZE type only; a sensor switch is not available in the single acting pull type).

Sensor switch

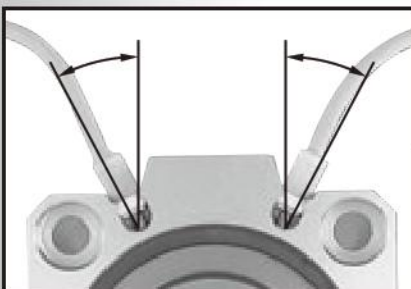
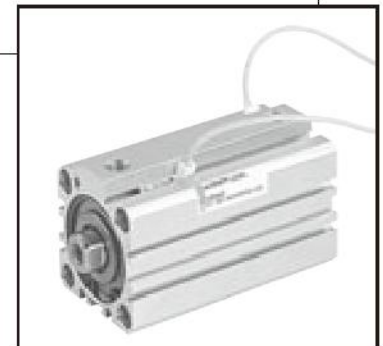

## Prevents Interference between Switches and Fittings

Slanting sensor switch mounting grooves on the connection port side prevent interference between the switches and the fittings.

	Operation type						Rod end type		Mounting bracket				
	Double acting type		Single acting push type		Single acting pull type		Female thread	Male thread	Foot	Axial foot	Rod side flange	Head side flange	With mounting thread
	No sensor	With sensor	No sensor	With sensor	No sensor	With sensor							
Standard	●	●	●	●	●	—	●	●	●	●	●	●	●
Double rod	●	●	—	—	—	—	●	●	●	●	—	—	●

**Operation type**

**Standard cylinder double acting type**



**Standard cylinder single acting push type**



**Standard cylinder single acting pull type**



**Double rod cylinder double acting type**



**Rod end specification**

**Female thread**  
(Basic type)



**Male thread (Optional)**



**Mounting option**

**With mounting thread**



**Head side flange mounting type**



**Rod side flange mounting type**



**Foot mounting type**



**Axial foot mounting type**



Discontinued



## General precautions

### Media

1. Always thoroughly blow off (use compressed air) the tubing before piping. Entering chips, sealing tape, rust, etc., generated during piping work could result in air leaks or other defective operation.
2. Use air for the media. For use of any other media, consult us.
3. Air used for the cylinder should be clean air that contains no deteriorated compressor oil, etc. Install an air filter (filtration of a minimum 40 μm) near the cylinder or valve to remove collected liquid or dust. In addition, drain the air filter periodically. Collected liquid or dust entering the cylinder may cause improper operation.

### Lubrication

The product can be used without lubrication, if lubrication is required, use Turbine Oil Class 1 (ISO VG32) or equivalent. Avoid using spindle oil or machine oil.

### Atmosphere

If using in locations subject to dripping water, dripping oil, etc., or to large amounts of dust, use a cover to protect the unit.

### Body mounting

1. The basic type includes 4 mounting through holes for hexagon socket head bolts. As an option, the mounting holes can be changed to double-sided thread. In sizes  $\phi 20$  [0.784in.] and  $\phi 25$  [0.984in.], however, the basic type includes both through mounting holes and mounting holes with double-sided threads located diagonally in each, and no option setting is available.
2. Some hexagon socket head bolts for direct mounting are provided for using the through mounting holes. See p.245, "Mounting Screws for Jig Cylinders." The nominal size of the hexagon socket head bolts for use in direct mounting are shown below.

Bore size	mm [in.]	20 [0.787]	25 [0.984]	32 [1.260]	40 [1.575]	50 [1.969]	63 [2.480]	80 [3.150]	100 [3.940]
Nominal size		M5	M5	M5	M5	M6	M8	M10	M10

### Bracket mounting

1. Axial foot mounting type JCDA32×5, JCDA80×10, JCSA32×5 and JCTA32×5 are not available because of interference with the brackets.
2. After purchasing the basic type cylinder in mounting type, the basic type cannot thereafter be changed to the foot mounting type, the axial foot mounting type, the flange mounting type, or with double-sided mounting thread type.
3. After purchasing the cylinder with flange mounting bracket on the rod side, the flange mounting bracket cannot be assembled on the head side. The same goes for the reverse situation.

### Lateral load, shock resistance

1. When applying a load on the piston rod end, use a guide, etc., to ensure that it is not subjected to a lateral load.
2. Install an external stopper, etc., to ensure that the cylinder is not subjected to direct impacts.

### Tightening thread on the end of piston rod

Since a tool (thin wrench) has been prepared for holding the piston rod when tightening the rod end thread, consult us.

Order code: L115069



### Non-standard stroke

- In most cases, body cutting is used for the manufacturing of non-standard strokes. However, body cutting is not used for strokes of less than 5mm for  $\phi 12$  [0.472in.]~ $\phi 40$  [1.575in.], and strokes of less than 10mm for  $\phi 50$  [1.969in.]~ $\phi 100$  [3.940in.]. The collar packed is used for these cases. (All cylinders with magnet are designed as body cutting.)

Remark: For delivery, consult us.

### Dimensions

1. Additional strokes obtained by body cutting remain classed as non-standard strokes.
2. Additional strokes obtained by collar packed are classed as standard strokes in the longer one.

### Sensor switch

In the Standard cylinder, a magnet for the sensor switch is not built-in. To install a sensor switch, a cylinder with a built-in magnet for the sensor switch is required.

- Notes:
1. For Handling Instructions and Precautions for Sensor Switches, see p.252.
  2. For the sensor switch mounting location and moving ranges, see p.247, 251.
  3. Contact protection measures are required for connecting inductive loads to reed sensor switches or when capacitive surges are generated. For contact protection measures, see p.1566.

## Maximum Kinetic Energy

The Jig Cylinders JC Series incorporates a cushion mechanism. This mechanism is used for reducing impacts as much as possible when the piston with high kinetic energy stops at the end of stroke.

### ● Rubber bumpers (as standard)

Rubber bumpers are installed on both sides of the piston to soften the impact at the end of stroke, absorbing impact noise during high cycle and high speed operations.

When using with rubber bumper, caution must be exercised that a certain rebound will occur at the end of stroke.

The kinetic energy of load can be found using the formula below.

$$E_x = \frac{m}{2} v^2$$

$E_x$  : Kinetic energy (J)  
 $m$  : Load mass (kg)  
 $v$  : Piston speed (m/s)

$$E'_x = \frac{W}{2g} v'^2$$

$E'_x$  : Kinetic energy [ft·lbf]  
 $W$  : Load [lbf.]  
 $v'$  : Piston speed [ft./sec.]  
 $g$  : Acceleration of gravity 32.2 [ft./sec.<sup>2</sup>]

J [ft·lbf]

Bore size mm [in.]	Maximum kinetic energy
20 [0.787]	0.27 [0.199]
25 [0.984]	0.40 [0.295]
32 [1.260]	0.65 [0.479]
40 [1.575]	1.20 [0.885]
50 [1.969]	2.00 [1.475]
63 [2.480]	3.40 [2.508]
80 [3.150]	5.90 [4.352]
100 [3.940]	9.90 [7.302]

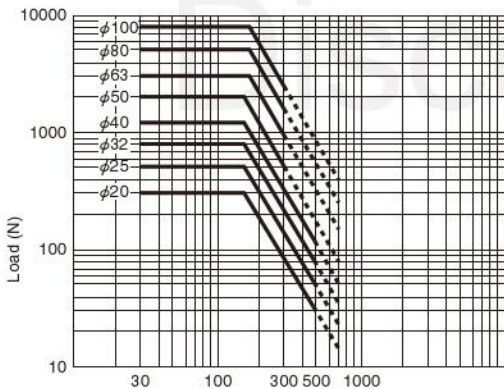

Maximum operating speed mm/s  
 1N = 0.2248 lbf.  
 1mm/s = 0.03937 in./sec.

### ● How to read the graph

The graph shows, when a load of 1000N [225lbf.] is carried by a φ 50 [1.969in.] Jig Cylinders JC Series, the rubber bumper performance requires that the maximum speed be restricted to 200mm/s [7.87in./sec.] or less.

# Spring Return Force

N [lbf.]

Operation type	Stroke mm	Bore size mm [in.]		20 [0.787]		25 [0.984]		32 [1.260]		40 [1.575]		50 [1.969]	
		Zero stroke	End of stroke	Zero stroke	End of stroke	Zero stroke	End of stroke	Zero stroke	End of stroke	Zero stroke	End of stroke	Zero stroke	End of stroke
Single acting push type	5	18.3 [4.11]	21.2 [4.77]	24.0 [5.40]	28.4 [6.38]	33.7 [7.58]	39.4 [8.86]	41.1 [9.24]	47.5 [10.68]	—	—	—	—
	10	15.6 [3.51]	21.4 [4.81]	19.9 [4.47]	30.7 [6.90]	28.5 [6.41]	39.2 [8.81]	34.7 [7.80]	54.5 [12.25]	48.0 [10.79]	60.0 [13.49]	41.9 [9.42]	60.6 [13.62]
	15	17.9 [4.02]		24.9 [5.60]		34.7 [7.80]		47.7 [10.72]		35.8 [8.05]		41.9 [9.42]	
	20	16.8 [3.78]	22.9 [5.15]	33.0 [7.42]	45.6 [10.25]	50.5 [11.35]	41.9 [9.42]	60.6 [13.62]					
	25	15.7 [3.53]	20.0 [4.50]	31.3 [7.04]	43.5 [9.78]	50.5 [11.35]	41.9 [9.42]	60.6 [13.62]					
	30	14.5 [3.26]	18.9 [4.25]	29.3 [6.59]	41.4 [9.31]	48.5 [10.90]	41.9 [9.42]	60.6 [13.62]					
	35	—	—	—	—	39.3 [8.83]	41.9 [9.42]	60.6 [13.62]					
	40	—	—	—	—	37.2 [8.36]	41.9 [9.42]	60.6 [13.62]					
	45	—	—	—	—	35.1 [7.89]	41.9 [9.42]	60.6 [13.62]					
50	—	—	—	—	33.0 [7.42]	41.9 [9.42]	60.6 [13.62]						
Single acting pull type	5	26.5 [5.96]	5.9 [1.33]	26.5 [5.96]	5.9 [1.33]	42.2 [9.49]	22.6 [5.08]	42.2 [9.49]	22.6 [5.08]	—	—	—	—
	10	27.5 [6.18]	6.9 [1.55]	27.5 [6.18]	6.9 [1.55]	41.2 [9.26]	—	41.2 [9.26]	—	82.4 [18.52]	23.5 [5.28]	—	—
	20	—	—	—	—	—	—	—	—	—	—	—	—

Note: "Zero stroke" refers to a situation where a piston rod is in the fully retracted position, "end of stroke" refers to a situation where a piston rod is in the fully extended position.

Discontinued

# Cylinder Thrust

Select a suitable cylinder bore size considering the load and air pressure to obtain the required thrust.

Since the figures in the table are calculated values, select a bore size that results in a load ratio (load ratio =  $\frac{\text{Load}}{\text{Calculated value}}$ ) of 70% or less (50% or less for high speed).

## ● Double acting type



N [lbf.]

Bore size mm [in.]	Piston rod diameter mm [in.]	Operation	Pressure area mm <sup>2</sup> [in. <sup>2</sup> ]	Air pressure MPa [psi.]									
				0.1 [15]	0.2 [29]	0.3 [44]	0.4 [58]	0.5 [73]	0.6 [87]	0.7 [102]	0.8 [116]	0.9 [131]	1.0 [145]
20 [0.787]	10 [0.394]	Push side	314.0 [0.487]	31.4 [7.06]	62.8 [14.12]	94.2 [21.18]	125.6 [28.23]	157.0 [35.29]	188.4 [42.35]	219.8 [49.41]	251.2 [56.47]	282.6 [63.53]	314.0 [70.59]
		Pull side	235.5 [0.365]	23.6 [5.31]	47.1 [10.59]	70.7 [15.89]	94.2 [21.18]	117.8 [26.48]	141.3 [31.76]	164.9 [37.07]	188.4 [42.35]	212.0 [47.66]	235.5 [52.94]
25 [0.984]	12 [0.472]	Push side	490.6 [0.760]	49.1 [11.04]	98.1 [22.05]	147.2 [33.09]	196.3 [44.13]	245.3 [55.14]	294.4 [66.18]	343.4 [77.20]	392.5 [88.23]	441.6 [99.27]	490.6 [110.3]
		Pull side	377.6 [0.585]	37.8 [8.50]	75.5 [16.97]	113.3 [25.47]	151.0 [33.94]	188.8 [42.44]	226.6 [50.94]	264.3 [59.41]	302.1 [67.91]	339.8 [76.39]	377.6 [84.88]
32 [1.260]	16 [0.630]	Push side	803.8 [1.246]	80.4 [18.07]	160.8 [36.15]	241.2 [54.22]	321.5 [72.27]	401.9 [90.35]	482.3 [108.4]	562.7 [126.5]	643.1 [144.6]	723.5 [162.6]	803.8 [180.7]
		Pull side	602.9 [0.934]	60.3 [13.56]	120.6 [27.11]	180.9 [40.67]	241.2 [54.22]	301.4 [67.75]	361.7 [81.31]	422.0 [94.87]	482.3 [108.4]	542.6 [122.0]	602.9 [135.5]
40 [1.575]	16 [0.630]	Push side	1256.0 [1.947]	125.6 [28.23]	251.2 [56.47]	376.8 [84.70]	502.4 [112.9]	628.0 [141.2]	753.6 [169.4]	879.2 [197.6]	1004.8 [225.9]	1130.4 [254.1]	1256.0 [282.3]
		Pull side	1055.0 [1.635]	105.5 [23.72]	211.0 [47.43]	316.5 [71.15]	422.0 [94.87]	527.5 [118.6]	633.0 [142.3]	738.5 [166.0]	844.0 [189.7]	949.5 [213.4]	1055.0 [237.2]
50 [1.969]	20 [0.787]	Push side	1962.5 [3.042]	196.3 [44.13]	392.5 [88.23]	588.8 [132.4]	785.0 [176.5]	981.3 [220.6]	1177.5 [264.7]	1373.8 [308.8]	1570.0 [352.9]	1766.3 [397.1]	1962.5 [441.2]
		Pull side	1648.5 [2.555]	164.9 [37.07]	329.7 [74.12]	494.6 [111.2]	659.4 [148.2]	824.3 [185.3]	989.1 [222.3]	1154.0 [259.4]	1318.8 [296.5]	1483.7 [333.5]	1648.5 [370.6]
63 [2.480]	20 [0.787]	Push side	3115.7 [4.829]	311.6 [70.05]	623.1 [140.1]	934.7 [210.1]	1246.3 [280.2]	1557.8 [350.2]	1869.4 [420.2]	2181.0 [490.3]	2492.5 [560.3]	2804.1 [630.4]	3115.7 [700.4]
		Pull side	2801.7 [4.343]	280.2 [62.99]	560.3 [126.0]	840.5 [188.9]	1120.7 [251.9]	1400.8 [314.9]	1681.0 [377.9]	1961.2 [440.9]	2241.3 [503.8]	2521.5 [566.8]	2801.7 [629.8]
80 [3.150]	25 [0.984]	Push side	5024.0 [7.787]	502.4 [112.9]	1004.8 [225.9]	1507.2 [338.8]	2009.6 [451.8]	2512.0 [564.7]	3014.4 [677.6]	3516.8 [790.6]	4019.2 [903.5]	4521.6 [1016.5]	5024.0 [1129.4]
		Pull side	4533.4 [7.027]	453.3 [101.9]	906.7 [203.8]	1360.0 [305.7]	1813.4 [407.7]	2266.7 [509.6]	2720.0 [611.5]	3173.4 [713.4]	3626.7 [815.3]	4080.0 [917.2]	4533.4 [1019.1]
100 [3.940]	30 [1.181]	Push side	7850.0 [12.168]	785.0 [176.5]	1570.0 [352.9]	2355.0 [529.4]	3140.0 [705.9]	3925.0 [882.3]	4710.0 [1058.8]	5495.0 [1235.3]	6280.0 [1411.7]	7065.0 [1588.2]	7850.0 [1764.7]
		Pull side	7143.5 [11.072]	714.4 [160.6]	1428.7 [321.2]	2143.1 [481.8]	2857.4 [642.3]	3571.8 [802.9]	4286.1 [963.5]	5000.5 [1124.1]	5714.8 [1284.7]	6429.2 [1445.3]	7143.5 [1605.9]

Note: For the thrust of double rod end cylinder, see the pull side of the thrust table.

## ● Single acting type

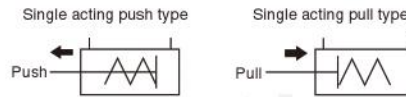

N [lbf.]

Operation type	Bore size mm [in.]	Piston rod diameter mm [in.]	Pressure area mm <sup>2</sup> [in. <sup>2</sup> ]	Stroke mm	Air pressure MPa [psi.]									
					0.1[15]	0.2 [29]	0.3 [44]	0.4 [58]	0.5 [73]	0.6 [87]	0.7 [102]	0.8 [116]	0.9 [131]	1.0 [145]
Single acting push type	20 [0.787]	10 [0.394]	314.0 [0.487]	5~10	—	41.6 [9.35]	73.0 [16.41]	104.4 [23.47]	135.8 [30.53]	167.2 [37.59]	198.6 [44.65]	230.0 [51.70]	261.4 [58.76]	292.8 [65.82]
				15~30	—	41.4 [9.31]	72.8 [16.37]	104.2 [23.42]	135.6 [30.48]	167.0 [37.54]	198.4 [44.60]	229.8 [51.66]	261.2 [58.72]	292.6 [65.78]
	25 [0.984]	12 [0.472]	490.6 [0.760]	5~10	—	69.7 [15.67]	118.8 [26.71]	167.9 [37.74]	216.9 [48.76]	266.0 [59.80]	315.0 [70.81]	364.1 [81.85]	413.2 [92.89]	462.2 [103.9]
				15~30	—	67.4 [15.15]	116.5 [26.19]	165.6 [37.23]	214.6 [48.24]	263.7 [59.28]	312.7 [70.29]	361.8 [81.33]	410.9 [92.37]	459.9 [103.4]
	32 [1.260]	16 [0.630]	803.8 [1.246]	5~10	41.0 [9.22]	121.4 [27.29]	201.8 [45.36]	282.1 [63.42]	362.5 [81.49]	442.9 [99.56]	523.3 [117.6]	603.7 [135.7]	684.1 [153.8]	764.4 [171.8]
				15~30	41.2 [9.26]	121.6 [27.34]	202.0 [45.41]	282.3 [63.46]	362.7 [81.53]	443.1 [99.61]	523.5 [117.7]	603.9 [135.8]	684.3 [153.8]	764.6 [171.9]
	40 [1.575]	16 [0.630]	1256.0 [1.947]	5~10	78.1 [17.56]	203.7 [45.79]	329.3 [74.03]	454.9 [102.3]	580.5 [130.5]	706.1 [158.7]	831.7 [187.0]	957.3 [215.2]	1082.9 [243.4]	1208.5 [287.9]
				15~50	71.1 [15.98]	196.7 [44.22]	322.3 [72.45]	447.9 [100.7]	573.5 [128.9]	699.1 [157.2]	824.7 [185.4]	950.3 [213.6]	1075.9 [241.9]	1201.5 [270.1]
	50 [1.969]	20 [0.787]	1962.5 [3.042]	10~15	136.3 [30.64]	332.5 [74.75]	528.8 [118.9]	725.0 [163.0]	921.3 [207.1]	1117.5 [251.2]	1313.8 [295.3]	1510.0 [339.4]	1706.3 [383.6]	1902.5 [427.7]
				20~50	135.7 [30.51]	331.9 [74.61]	528.2 [118.7]	724.4 [162.8]	920.7 [207.0]	1116.9 [251.1]	1313.2 [295.2]	1509.4 [339.3]	1705.7 [383.4]	1901.9 [427.5]
Single acting pull type	20 [0.787]	10 [0.394]	235.5 [0.365]	5	—	41.2 [9.26]	64.8 [14.57]	88.3 [19.85]	111.9 [25.16]	135.4 [30.44]	159.0 [35.74]	182.5 [41.03]	206.1 [46.33]	229.6 [51.61]
				10	—	40.2 [9.04]	63.8 [14.34]	87.3 [19.63]	110.9 [24.93]	134.4 [30.21]	158.0 [35.52]	181.5 [40.80]	205.1 [46.11]	228.6 [51.39]
	25 [0.984]	12 [0.472]	377.6 [0.585]	5	—	69.6 [15.65]	107.4 [24.14]	145.1 [32.62]	182.9 [41.12]	220.7 [49.61]	258.4 [58.09]	296.2 [66.59]	333.9 [75.06]	371.7 [83.56]
				10	—	68.6 [15.42]	106.4 [23.92]	144.1 [32.39]	181.9 [40.89]	219.7 [49.39]	257.4 [57.86]	295.2 [66.36]	332.9 [74.84]	370.7 [83.33]
	32 [1.260]	16 [0.630]	602.9 [0.934]	5, 10	37.7 [8.47]	98.0 [22.03]	158.3 [35.59]	218.6 [49.14]	278.8 [62.67]	339.1 [76.23]	399.4 [89.79]	459.7 [103.3]	520.0 [116.9]	580.3 [130.5]
				5, 10	82.9 [18.64]	188.4 [42.35]	293.9 [66.07]	399.4 [89.79]	504.9 [113.5]	610.4 [137.2]	715.9 [160.9]	821.4 [184.7]	926.9 [208.4]	1032.4 [232.1]
	40 [1.575]	16 [0.630]	1055.0 [1.635]	5, 10	82.9 [18.64]	188.4 [42.35]	293.9 [66.07]	399.4 [89.79]	504.9 [113.5]	610.4 [137.2]	715.9 [160.9]	821.4 [184.7]	926.9 [208.4]	1032.4 [232.1]
				10, 20	141.4 [31.79]	306.2 [68.83]	471.1 [105.9]	635.9 [143.0]	800.8 [180.0]	965.6 [217.1]	1130.5 [254.1]	1295.3 [291.2]	1460.2 [328.3]	1625.0 [365.3]
	50 [1.969]	20 [0.787]	1648.5 [2.555]	10, 20	141.4 [31.79]	306.2 [68.83]	471.1 [105.9]	635.9 [143.0]	800.8 [180.0]	965.6 [217.1]	1130.5 [254.1]	1295.3 [291.2]	1460.2 [328.3]	1625.0 [365.3]

# JIG CYLINDERS JC SERIES

## Standard Cylinders

Double Acting Type, Single Acting Push Type, Single Acting Pull Type



## Symbols

● Double acting type ● Single acting push type ● Single acting pull type



## Specifications

Item	Bore size mm [in.]	20 [0.787]	25 [0.984]	32 [1.260]	40 [1.575]	50 [1.969]	63 [2.480]	80 [3.150]	100 [3.940]
		Operation type		Double acting type, Single acting push type, Single acting pull type					Double acting type
Media		Air							
Mounting type		Basic type		Basic type, foot type, axial foot type, rod/head side flange type, with double-sided mounting thread					
Rod end specification		Female thread, male thread (optional)							
Operating pressure range <sup>Note 1</sup> MPa [psi.]	Double acting type	0.1~1.0 [15~145]			0.05~1.0 [7~145]				
	Single acting type	0.18~1.0 [26~145]		0.12~1.0 [17~145]			—		
Proof pressure	MPa [psi.]	1.5 [218]							
Operating temperature range	°C [°F]	-10~70 [14~158] (0~60 [32~140] for with sensor) <sup>Note 2</sup>							
Operating speed range mm/s [in./sec.]	Double acting type	30~500 [1.2~19.7]					30~300 [1.2~11.8]		
	Single acting type	100~500 [3.9~19.7]				100~300 [3.9~11.8]		—	
Cushion		Rubber bumper <sup>Note 3</sup>							
Lubrication		Not required (If lubrication is required, use Turbine Oil Class 1 (ISO VG32) or equivalent.)							
Port size		M5X0.8		Rc1/8		Rc1/4		Rc3/8	
Stroke tolerance	mm [in.]	+1 [ +0.039 ] 0 [ 0 ]							
Applicable standards		JIS B 8368 1PS space-saving cylinder <sup>Note 4</sup>							

Notes : 1. While the minimum operating pressure is included, the breakaway pressure is not included.

2. When using at temperature of -10~0°C [14~32°F], be careful to avoid freezing.

3. Installed on the spring return side only for the single acting type. However, bumpers installed on both sides in the single acting pull type available in JCTA 40 and 50 only.

4. This is only applicable to the basic mounting type in the standard double acting cylinder with magnet and sensor switch. Also includes the male rod thread specifications.

## Bore Size and Stroke

Operation type	Bore size	Standard strokes		Maximum available stroke
		mm		
Double acting type	20	5, 10, 15, 20, 25, 30, 35, 40, 45, 50, 60, 70		70
	25			
	32			
	40	5, 10, 15, 20, 25, 30, 35, 40, 45, 50, 60, 70, 75, 80, 90, 100		100
	50			
	63			
	80	10, 15, 20, 25, 30, 35, 40, 45, 50, 60, 70, 75, 80, 90, 100		
Single acting push type	20	5, 10, 15, 20, 25, 30		30
	25			
	32			
	40	5, 10, 15, 20, 25, 30, 35, 40, 45, 50		50
	50	10, 15, 20, 25, 30, 35, 40, 45, 50		
Single acting pull type	20			10
	25	5, 10		
	32			
	40			
	50	10, 20		20

Remark: The non-standard stroke (see p.213) in increment of 1mm is set for double acting type only. Consult us about delivery. (For single acting type, consult us.)

# Order Codes

## Standard cylinders

**JC** - **40×100** - [ ] - [ ] - [ ] - [ ] - [ ]

**Jig Cylinders JC Series**

**Operation type**<sup>Note 1</sup>  
**DA**: Double acting type  
**SA**: Single acting push type  
**TA**: Single acting pull type

**Cylinder specification**<sup>Note 2</sup>  
**Blank**: Standard cylinder (Sensor switch non-compatible type)  
**S**: Cylinder with magnet

**Bore size × Stroke**<sup>Note 3</sup>  
**Blank**: Female thread  
**B**: Male thread

**Rod end specification**  
**Blank**: Female thread  
**B**: Male thread

**Mounting type**<sup>Notes 4, 5, 6</sup>  
**Blank**: Basic type (without double-sided mounting thread)  
**1**: Foot mounting type  
**2**: Axial foot mounting type  
**3**: Rod side flange mounting type  
**5**: Head side flange mounting type  
**13**: With double-sided mounting thread

**Number of sensor switches**  
**1**: With 1 sensor switch  
**2**: With 2 sensor switches  
**⋮**  
**n**: With n sensor switches

**Lead wire length**<sup>Note 9</sup>  
**A**: 1000mm [39in.]  
**B**: 3000mm [118in.]  
**C**: 5000mm [197in.]

**Sensor switch type**<sup>Note 7</sup>  
**Blank**: No sensor switch  
**ZE101**: Reed switch type without indicator lamp, Horizontal lead wire DC5~28V, AC85~115V  
**ZE102**: Reed switch type with indicator lamp, Horizontal lead wire DC10~28V, AC85~115V  
**ZE201**: Reed switch type without indicator lamp, Vertical lead wire<sup>Note 8</sup> DC5~28V, AC85~115V  
**ZE202**: Reed switch type with indicator lamp, Vertical lead wire<sup>Note 8</sup> DC10~28V, AC85~115V  
**ZE135**: 2-lead wire Solid state type with indicator lamp, Horizontal lead wire DC10~28V  
**ZE155**: 3-lead wire Solid state type with indicator lamp, Horizontal lead wire DC4.5~28V  
**ZE235**: 2-lead wire Solid state type with indicator lamp, Vertical lead wire<sup>Note 8</sup> DC10~28V  
**ZE255**: 3-lead wire Solid state type with indicator lamp, Vertical lead wire<sup>Note 8</sup> DC4.5~28V  
**ZD136**: Strong magnetic field resistant sensor switch 2-lead wire Solid state type with indicator lamp, Horizontal lead wire DC10~28V

● For details of sensor switches, see p.246, 249.

Notes: 1. Single acting type available for  $\phi 20$  [0.787in.] to  $\phi 50$  [1.969in.] only.  
 2. Sensor switch compatible single acting pull type is not available.  
 3. For the bore size and stroke, see p.217.  
 4. Mounting brackets are available for  $\phi 32$  [1.260in.] to  $\phi 100$  [3.940in.] only.  
 5. Axial foot mounting type JCDA, JCSA, JCTA32 X 5, and JCDA80 X 10 are not available because of brackets interference.  
 6. After purchasing the basic body type, it cannot thereafter be changed to the foot mounting type, the axial foot mounting type, the flange mounting type, or with double-sided mounting thread.  
 7. ZD136 is available only for  $\phi 32$  [1.260in.] to  $\phi 100$  [3.940in.].  
 8. The vertical lead wire type means the lead wire comes the sensor switch at perpendicular direction.  
 9. A and B are available with the ZE type only, C is with the ZD type only.  
 Remark: Cylinder joints and cylinder rod ends are available for mounting with the rod end male thread specification (excluding  $\phi 20$ ). For details, see p.1568.

## Mounting bracket only<sup>Note 1</sup>

[ ] - **JCDA** - [ ]

**Mounting bracket**  
**1**: Foot mounting type  
**2**: Axial foot mounting type  
**3**: Flange mounting type (common to both rod and head sides)  
**N**: Rod end nut (for piston rod with male thread specifications)

**Bore size**  
**20**: For  $\phi 20$  [0.787in.]<sup>Note 2</sup>  
**25**: For  $\phi 25$  [0.984in.]<sup>Note 2</sup>  
**32**: For  $\phi 32$  [1.260in.]  
**40**: For  $\phi 40$  [1.575in.]  
**50**: For  $\phi 50$  [1.969in.]  
**63**: For  $\phi 63$  [2.480in.]  
**80**: For  $\phi 80$  [3.150in.]  
**100**: For  $\phi 100$  [3.940in.]

Notes: 1. Purchased mounting brackets could not be installed to the product. Before ordering, always see and check p.213 "Bracket mounting."  
 2. For  $\phi 20$  [0.787in.] and  $\phi 25$  [0.984in.], only N (rod end nut) is available.

### Mounting bracket contents

Model	Contents	pc.
1 - JCDA [ ]	Bracket:2 Mounting bolt:4	
2 - JCDA [ ]	Bracket:2 Mounting bolt:4	
3 - JCDA [ ]	Bracket:1 Mounting bolt:4	
N - JCDA [ ]	Hexagon nut:1	

## Repair kit only

**SRK** - [ ] - [ ]

**Cylinder operation type**  
**JCDA**: Single rod double acting type  
**JCSA**: Single rod single acting push type  
**JCTA**: Single rod single acting pull type

**Repair kit**  
**SRK**: Repair kit 1 set

**Bore size**  
**20**: For  $\phi 20$  [0.787in.]  
**25**: For  $\phi 25$  [0.984in.]  
**32**: For  $\phi 32$  [1.260in.]  
**40**: For  $\phi 40$  [1.575in.]  
**50**: For  $\phi 50$  [1.969in.]  
**63**: For  $\phi 63$  [2.480in.]  
**80**: For  $\phi 80$  [3.150in.]  
**100**: For  $\phi 100$  [3.940in.]

### Contents of repair kit

Parts	Bore size		JCDA							
	mm	Operating type	20	25	32	40	50	63	80	100
⑧ Rod seal			1	1	1	1	1	1	1	1
⑨ Piston seal			1	1	1	1	1	1	1	1
⑩ Tube gasket			1	1	1	2	2	2	2	2

JCSA					JCTA				
20	25	32	40	50	20	25	32	40	50
—	—	—	—	—	—	—	—	—	—
1	1	1	1	1	1	1	1	1	1
—	—	—	1	1	1	1	1	1	1

Remark: Numbers ⑧, ⑨, ⑩ are part numbers on p.220.

JIG CYLINDERS JC SERIES

# Mass

## ● Standard cylinders: Double acting type

g [oz.]

Bore size mm [in.]	Zero stroke mass (basic type)	Additional mass for each 1mm [0.0394in.] stroke	Additional mass of mounting bracket			Additional mass of other options			
			Foot bracket	Axial foot bracket	Flange bracket	Male thread piston rod	Cylinder with magnet	ZE□□□ switch	ZD136 switch
<b>20 [0.787]</b>	57.8 [2.039]	2.42 [0.0854]	—	—	—	10 [0.35]	28.2 [0.995]	A:15 [0.53] B:35 [1.23]	C:270 [9.52]
<b>25 [0.984]</b>	77.3 [2.727]	3.19 [0.1125]	—	—	—	20 [0.71]	38.2 [1.347]		
<b>32 [1.260]</b>	99.7 [3.517]	4.08 [0.1439]	84 [2.96]	96 [3.39]	210 [7.41]	43 [1.52]	50.8 [1.792]		
<b>40 [1.575]</b>	175.6 [6.194]	4.83 [0.1704]	100 [3.53]	110 [3.88]	275 [9.70]	43 [1.52]	72.0 [2.540]		
<b>50 [1.969]</b>	275.5 [9.718]	7.31 [0.2578]	150 [5.29]	160 [5.64]	415 [14.64]	74 [2.61]	109.3 [3.855]		
<b>63 [2.480]</b>	436.6 [15.40]	8.56 [0.3019]	240 [8.47]	260 [9.17]	560 [19.75]	74 [2.61]	156.1 [5.506]		
<b>80 [3.150]</b>	874.6 [30.85]	13.71 [0.4836]	500 [17.64]	520 [18.34]	1515 [53.44]	162 [5.71]	247.0 [8.713]		
<b>100 [3.940]</b>	1553.5 [54.80]	18.86 [0.6653]	580 [20.46]	590 [20.81]	1950 [68.78]	291 [10.26]	360.3 [12.71]		

- Notes: 1. The flange bracket is common to be used for the rod side and head side. Therefore, the same mass is applied for both.  
 2. "With double-sided mounting thread" has the same mass as the basic type.  
 3. Includes the mass for bracket mounting bolts, the rod end nut in the male thread specifications, and the sensor switch mounting brackets.  
 4. The sensor switch codes A, B, and C show the lead wire lengths. (A:1000mm [39in.], B:3000mm [118in.], C:5000mm [197in.])

## ● Standard cylinders: Single acting push type

g [oz.]

Stroke mm	Mass by stroke									
	5	10	15	20	25	30	35	40	45	50
<b>20 [0.787]</b>	72.5 [2.557]	84.6 [2.984]	112.1 [3.954]	124.2 [4.381]	136.3 [4.808]	148.4 [5.235]	—	—	—	—
<b>25 [0.984]</b>	100.7 [3.552]	116.6 [4.113]	155.9 [5.499]	171.8 [6.060]	187.8 [6.624]	203.7 [7.185]	—	—	—	—
<b>32 [1.260]</b>	135.0 [4.762]	155.4 [5.481]	213.6 [7.534]	234.0 [8.254]	254.4 [8.974]	274.8 [9.693]	—	—	—	—
<b>40 [1.575]</b>	220.5 [7.778]	244.6 [8.628]	342.6 [12.08]	366.8 [12.94]	390.9 [13.79]	415.1 [14.64]	439.2 [15.49]	463.4 [16.35]	487.5 [17.20]	511.7 [18.05]
<b>50 [1.969]</b>	—	368.9 [13.01]	511.6 [18.05]	548.2 [19.34]	584.7 [20.62]	621.3 [21.92]	657.8 [23.20]	694.4 [24.49]	730.9 [25.78]	767.5 [27.07]

Note: Additional mass for mounting brackets and other options is the same as for the double acting type.

## ● Standard cylinders: Single acting pull type g [oz.]

Stroke mm	Mass by stroke		
	5	10	20
<b>20 [0.787]</b>	76.9 [2.713]	87.2 [3.076]	—
<b>25 [0.984]</b>	106.4 [3.753]	120.6 [4.254]	—
<b>32 [1.260]</b>	139.0 [4.903]	153.4 [5.411]	—
<b>40 [1.575]</b>	224.7 [7.926]	242.7 [8.561]	—
<b>50 [1.969]</b>	—	385.2 [13.59]	443.0 [15.63]

Note: Additional mass for mounting brackets and other options is the same as for the double acting type.

Calculation example: For the mass of a double acting type cylinder with magnet, bore size of 25mm, stroke of 30mm, and with 2 sensor switches (ZE135A)  
 $77.3 + 38.2 + (3.19 \times 30) + (15 \times 2) = 241.2g [8.508oz.]$

## Inner Construction

### ● Double acting type $\phi 20$ , $\phi 25$ , $\phi 32$ (JCDA)

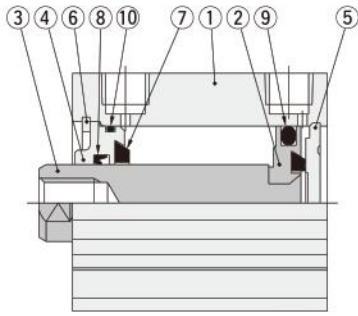

### ● Single acting push type (JCSA)

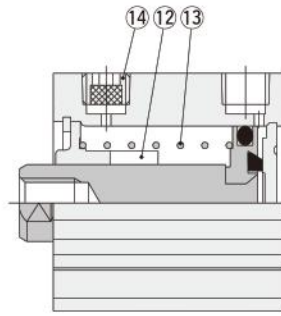

### ● Double acting type $\phi 40$ , $\phi 50$ , $\phi 63$ (JCDA)

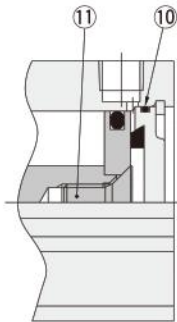

### ● Single acting pull type (JCTA)

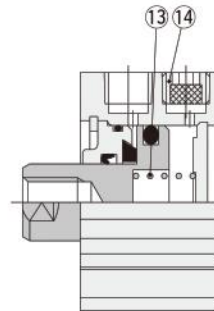

### ● Double acting type $\phi 80$ , $\phi 100$ (JCDA)

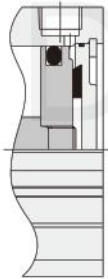

### ● Cylinder with magnet (JCDAS)

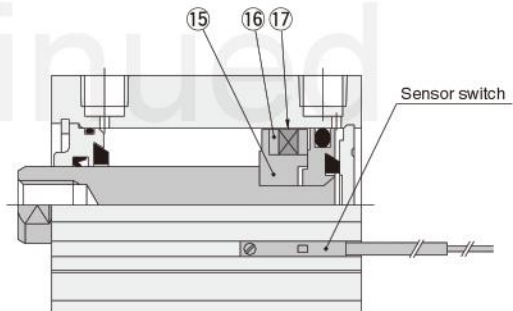

## Major Parts and Materials

No.	Parts	Bore size mm [in.]	20 [0.787]	25 [0.984]	32 [1.260]	40 [1.575]	50 [1.969]	63 [2.480]	80 [3.150]	100 [3.940]
①	Cylinder body		Aluminum alloy (anodized)							
②	Piston		Aluminum alloy (wear-resistant surface treatment)							
③	Piston rod <sup>Note</sup>		Stainless steel (chrome plated)	Steel (chrome plated)						
④	Rod cover		Aluminum alloy (wear-resistant surface treatment)							
⑤	Head cover		Aluminum alloy (anodized)							
⑥	Snap ring		Steel (black oxide finish)							
⑦	Bumper		Synthetic rubber (urethane rubber)							
⑧	Rod seal		Synthetic rubber (NBR)							
⑨	Piston seal		Synthetic rubber (NBR)							
⑩	Tube gasket		Synthetic rubber (NBR)							
⑪	Piston setscrew		—	Steel (black oxide finish)				—		
⑫	Spacer		Aluminum alloy (anodized)				—			
⑬	Spring		Piano wire				—			
⑭	Filter plug		Plastic				Mild steel (zinc plated)	—		
⑮	Support		Aluminum alloy (anodized)							
⑯	Yoke		—	Mild steel (zinc plated)	—					—
⑰	Magnet		Plastic magnet							

Note: The material of the single acting pull type ( $\phi 20$  to  $\phi 50$ ) piston rod is stainless steel.

## Seals

Bore size mm [in.]	Parts	Rod seal	Piston seal	Tube gasket
20 [0.787]		MYN-10	PWP-20N	S-18
25 [0.984]		MYN-12	PWP-25N	S-22
32 [1.260]		MYN-16	PWP-32N	$\phi 29 \times \phi 1.5$
40 [1.575]		DRP-16	PWP-40N	$\phi 39.5 \times \phi 1.5$
50 [1.969]		DRP-20	PWP-50N	$\phi 49.5 \times \phi 1.5$
63 [2.480]		DRP-20	PWP-63N	$\phi 62.5 \times \phi 1.5$
80 [3.150]		DRP-25	PWP-80N	$\phi 77.3 \times \phi 1.5$
100 [3.940]		DRP-30	PWP-100N	$\phi 98.5 \times \phi 2$

## Mounting Bracket Materials

Parts	Materials
Rod end nut (for male thread)	Steel (zinc plated)
Foot bracket	Mild steel (black zinc plated)
Axial foot bracket	Mild steel (black zinc plated)
Flange bracket	Mild steel (black oxide finish)
Bracket mounting bolt	Steel (black oxide finish)

# Dimensions of Standard Cylinder Double Acting Type (mm)

● Basic type JCDA □ Bore size × Stroke (φ 20, φ 25)

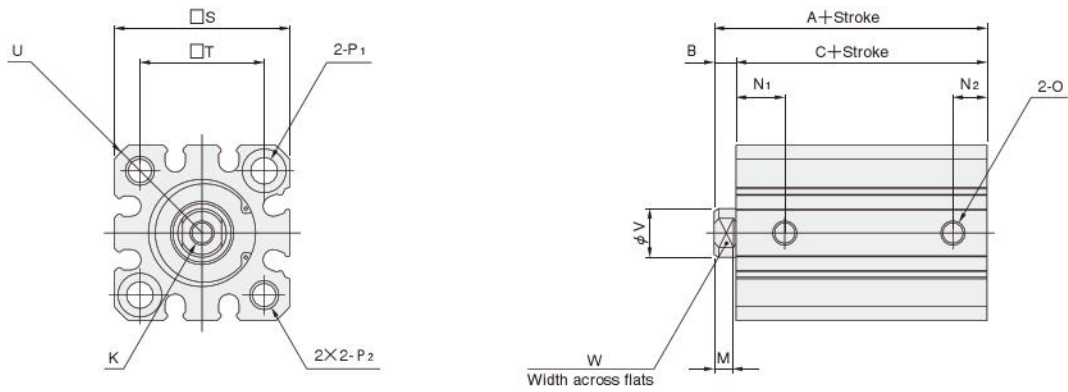

● Basic type JCDA □ Bore size × Stroke (φ 32~φ 100)

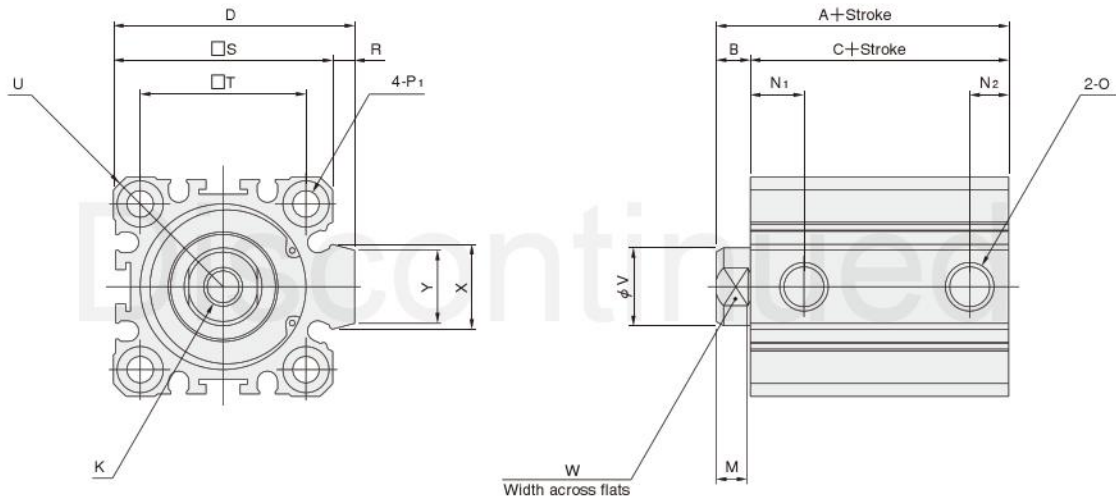

Type Stroke Code	Standard cylinder (JCDA)			Cylinder with magnet (JCDAS)			D	K		M	JCDA				JCDAS	
	A	B	C	A	B	C					5		10 or more		N <sub>1</sub>	N <sub>2</sub>
					N <sub>1</sub>	N <sub>2</sub>					N <sub>1</sub>	N <sub>2</sub>				
20 [0.787]	26	4.5	21.5	36	4.5	31.5	—	M5×0.8	Depth7	4	9	6	10	7	10	7
25 [0.984]	27.5	5	22.5	37.5	5	32.5	—	M6×1	Depth12	4.5	9	6	10	7	10	7
32 [1.260]	30	7	23	40	7	33	49.5	M8×1.25	Depth13	6.5	10	6	11	8	11	8
40 [1.575]	36.5	7	29.5	46.5	7	39.5	57	M8×1.25	Depth13	6.5	10	10	11.5	11.5	11.5	11.5
50 [1.969]	38.5	8	30.5	48.5	8	40.5	71	M10×1.5	Depth15	7	—	—	12	12	12	12
63 [2.480]	44	8	36	54	8	46	84	M10×1.5	Depth15	7	—	—	14.5	14.5	14.5	14.5
80 [3.150]	53.5	10	43.5	63.5	10	53.5	104	M16×2	Depth21	9	—	—	16.5	16.5	16.5	16.5
100 [3.940]	65	12	53	75	12	63	123.5	M20×2.5	Depth27	11	—	—	21	21	21	21

Code	O	P <sub>1</sub>			P <sub>2</sub>	R	S	T	U	V	W	X	Y
20 [0.787]	M5×0.8	φ 5.5 (Through hole)	Counterbore φ 9	Depth5.4 (Both sides)	M6×1 Depth10	—	36	25.5	R23.5	10	8	—	—
25 [0.984]	M5×0.8	φ 5.5 (Through hole)	Counterbore φ 9	Depth5.4 (Both sides)	M6×1 Depth10	—	40	28	R26	12	10	—	—
32 [1.260]	Rc1/8	φ 5.5 (Through hole)	Counterbore φ 9	Depth5.4 (Both sides)	—	4.5	45	34	R30	16	14	17.4	15
40 [1.575]	Rc1/8	φ 5.5 (Through hole)	Counterbore φ 9	Depth5.4 (Both sides)	—	5	52	40	R34.5	16	14	20.5	17.5
50 [1.969]	Rc1/4	φ 6.6 (Through hole)	Counterbore φ 11	Depth8 (Both sides)	—	7	64	50	R42.5	20	17	21.6	19
63 [2.480]	Rc1/4	φ 9 (Through hole)	Counterbore φ 14	Depth10.5 (Both sides)	—	7	77	60	R51	20	17	21.6	19
80 [3.150]	Rc3/8	φ 11 (Through hole)	Counterbore φ 17.5	Depth13.5 (Both sides)	—	6	98	77	R65	25	22	27.6	25
100 [3.940]	Rc3/8	φ 11 (Through hole)	Counterbore φ 17.5	Depth13.5 (Both sides)	—	6.5	117	94	R78	30	27	27.6	25

# Dimensions of Standard Cylinder Double Acting Type (mm)

● Foot mounting type JCDA □ Bore size × Stroke -1

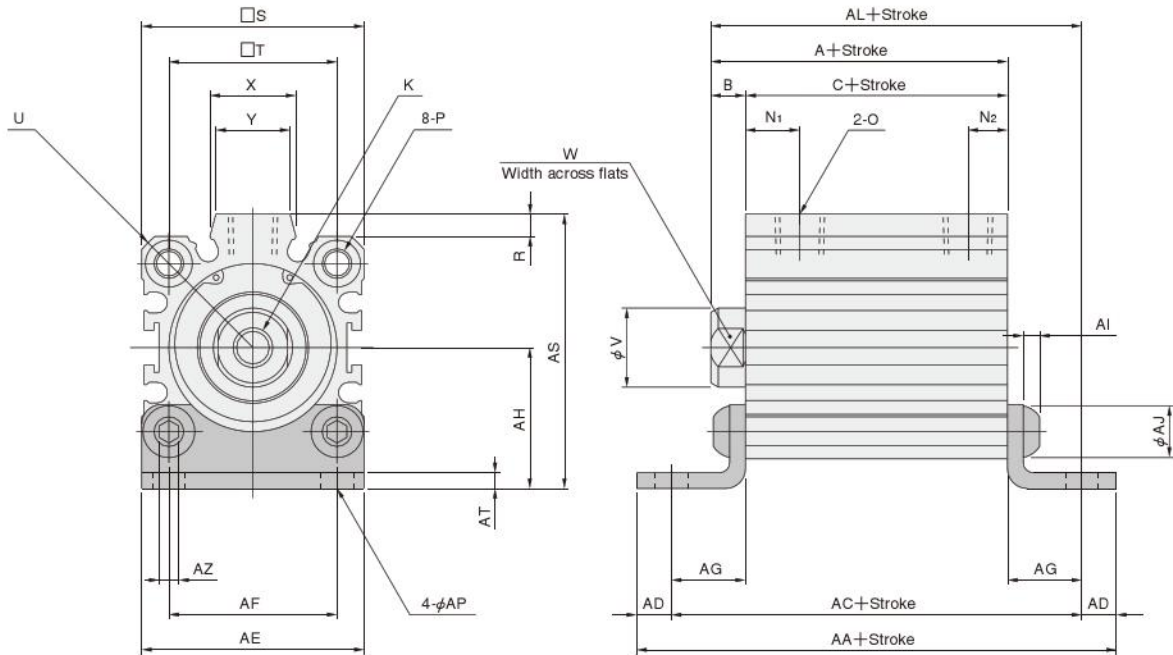

Discontinued

JIG CYLINDERS JC SERIES

Type Stroke Code	Standard cylinder (JCDA)			Cylinder with magnet (JCDAS)			K	JCDA				JCDAS		O
	A	B	C	A	B	C		5		10 or more		N <sub>1</sub>	N <sub>2</sub>	
								N <sub>1</sub>	N <sub>2</sub>	N <sub>1</sub>	N <sub>2</sub>			
32 [1.260]	30	7	23	40	7	33	M8×1.25 Depth13	10	6	11	8	11	8	Rc1/8
40 [1.575]	36.5	7	29.5	46.5	7	39.5	M8×1.25 Depth13	10	10	11.5	11.5	11.5	11.5	Rc1/8
50 [1.969]	38.5	8	30.5	48.5	8	40.5	M10×1.5 Depth15	—	—	12	12	12	12	Rc1/4
63 [2.480]	44	8	36	54	8	46	M10×1.5 Depth15	—	—	14.5	14.5	14.5	14.5	Rc1/4
80 [3.150]	53.5	10	43.5	63.5	10	53.5	M16×2 Depth21	—	—	16.5	16.5	16.5	16.5	Rc3/8
100 [3.940]	65	12	53	75	12	63	M20×2.5 Depth27	—	—	21	21	21	21	Rc3/8

Type Code	P												R	S	T	U	V	W	X	Y	JCDA	JCDAS
													AA	AA								
32 [1.260]	Counterbore φ9	Depth 5.4 (Both sides), M6X1	Depth from main body end 17.4 (Both sides)	4.5	45	34	R30	16	14	17.4	15	67	77									
40 [1.575]	Counterbore φ9	Depth 5.4 (Both sides), M6X1	Depth from main body end 17.4 (Both sides)	5	52	40	R34.5	16	14	20.5	17.5	73.5	83.5									
50 [1.969]	Counterbore φ11	Depth 8 (Both sides), M8X1.25	Depth from main body end 22 (Both sides)	7	64	50	R42.5	20	17	21.6	19	84.5	94.5									
63 [2.480]	Counterbore φ14	Depth10.5 (Both sides), M10X1.5	Depth from main body end 28.5 (Both sides)	7	77	60	R51	20	17	21.6	19	98	108									
80 [3.150]	Counterbore φ17.5	Depth13.5 (Both sides), M12X1.75	Depth from main body end 35.5 (Both sides)	6	98	77	R65	25	22	27.6	25	121.5	131.5									
100 [3.940]	Counterbore φ17.5	Depth13.5 (Both sides), M12X1.75	Depth from main body end 35.5 (Both sides)	6.5	117	94	R78	30	27	27.6	25	131	141									

Type Code	JCDA	JCDAS	AD	AE	AF	AG	AH	AI	AJ	JCDA	JCDAS	AP	AS	AT	AZ
	AC	AC								AL	AL				
32 [1.260]	53	63	7	45	34	15	28.5	4	10.5	45	55	6.6	55.5	3.2	4
40 [1.575]	59.5	69.5	7	53	40	15	32.5	4	10.5	51.5	61.5	6.6	63.5	3.2	4
50 [1.969]	66.5	76.5	9	64	50	18	38	5	14	56.5	66.5	9	77	3.2	5
63 [2.480]	76	86	11	77	60	20	44.5	6	17.5	64	74	11	90	3.2	6
80 [3.150]	93.5	103.5	14	100	77	25	58.5	7	21	78.5	88.5	14	113.5	4.5	8
100 [3.940]	103	113	14	117	94	25	67	7	21	90	100	14	132	4.5	8

# Dimensions of Standard Cylinder Double Acting Type (mm)

● Axial foot mounting type JCDA □ Bore size × Stroke -2

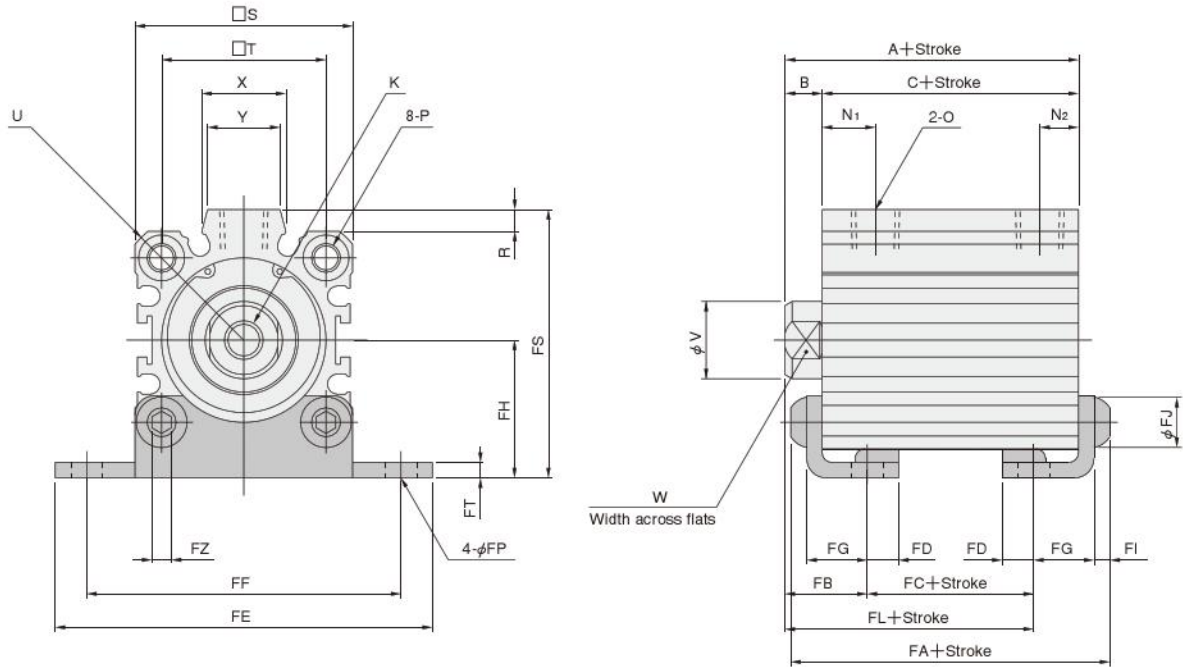

Discontinued

Type Stroke Code	Standard cylinder (JCDA)			Cylinder with magnet (JCDAS)			K	JCDA				JCDAS		O	
	A	B	C	A	B	C		5		10 or more		N <sub>1</sub>	N <sub>2</sub>		
								N <sub>1</sub>	N <sub>2</sub>	N <sub>1</sub>	N <sub>2</sub>				
32 [1.260]	30	7	23	40	7	33	M8×1.25	Depth13	—	—	11	8	11	8	Rc1/8
40 [1.575]	36.5	7	29.5	46.5	7	39.5	M8×1.25	Depth13	10	10	11.5	11.5	11.5	11.5	Rc1/8
50 [1.969]	38.5	8	30.5	48.5	8	40.5	M10×1.5	Depth15	—	—	12	12	12	12	Rc1/4
63 [2.480]	44	8	36	54	8	46	M10×1.5	Depth15	—	—	14.5	14.5	14.5	14.5	Rc1/4
80 [3.150]	53.5	10	43.5	63.5	10	53.5	M16×2	Depth21	—	—	16.5	16.5	16.5	16.5	Rc3/8
100 [3.940]	65	12	53	75	12	63	M20×2.5	Depth27	—	—	21	21	21	21	Rc3/8

Type Code	P				R	S	T	U	V	W	X	Y	JCDA	JCDAS	FB
	FA		FA												
32 [1.260]	Counterbore φ9	Depth 5.4 (Both sides)	M6×1	Depth from main body end 17.4 (Both sides)	4.5	45	34	R30	16	14	17.4	15	37.4	47.4	16.3
40 [1.575]	Counterbore φ9	Depth 5.4 (Both sides)	M6×1	Depth from main body end 17.4 (Both sides)	5	52	40	R34.5	16	14	20.5	17.5	43.9	53.9	16.3
50 [1.969]	Counterbore φ11	Depth 8 (Both sides)	M8×1.25	Depth from main body end 22 (Both sides)	7	64	50	R42.5	20	17	21.6	19	46.9	56.9	18.8
63 [2.480]	Counterbore φ14	Depth10.5 (Both sides)	M10×1.5	Depth from main body end 28.5 (Both sides)	7	77	60	R51	20	17	21.6	19	54.4	64.4	20.3
80 [3.150]	Counterbore φ17.5	Depth13.5 (Both sides)	M12×1.75	Depth from main body end 35.5 (Both sides)	6	98	77	R65	25	22	27.6	25	66.5	76.5	26.5
100 [3.940]	Counterbore φ17.5	Depth13.5 (Both sides)	M12×1.75	Depth from main body end 35.5 (Both sides)	6.5	117	94	R78	30	27	27.6	25	76	86	28.5

Type Code	JCDA	JCDAS	FD	FE	FF	FG	FH	FI	FJ	JCDA	JCDAS	FP	FS	FT	FZ
	FC	FC								FL	FL				
32 [1.260]	4.4	14.4	6.5	78	65	12.5	28.5	4	10.5	20.7	30.7	6.6	55.5	3.2	4
40 [1.575]	10.9	20.9	6.5	87	73	12.5	32.5	4	10.5	27.2	37.2	6.6	63.5	3.2	4
50 [1.969]	8.9	18.9	8	103	87	14	38	5	14	27.7	37.7	9	77	3.2	5
63 [2.480]	11.4	21.4	9.5	127	109	15.5	44.5	6	17.5	31.7	41.7	11	90	3.2	6
80 [3.150]	10.5	20.5	11	145	123	21	58.5	7	21	37	47	14	113.5	4.5	8
100 [3.940]	20	30	11	159	137	21	67	7	21	48.5	58.5	14	132	4.5	8

Remark: The axial foot mounting type is not available for JCDA32×5 and JCDA80×10. (The brackets cause interference unless the stroke for φ32 is 10mm or more, and for φ80 the stroke is 15mm or more.)

# Dimensions of Standard Cylinder Double Acting Type (mm)

● Rod side flange mounting type JCDA □ Bore size × Stroke -3

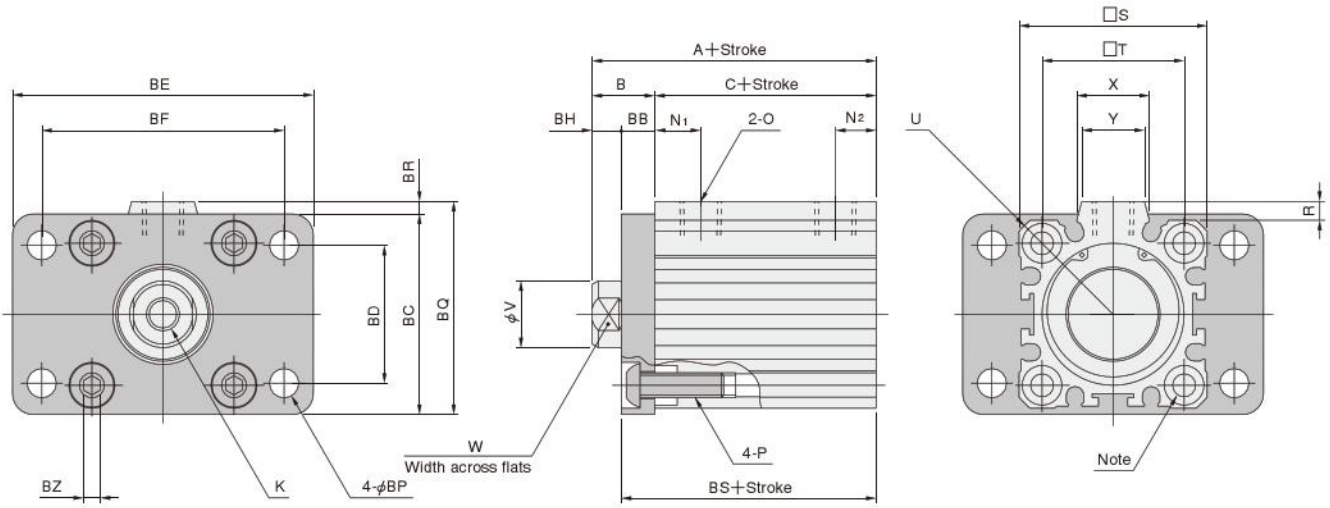

Note: The flange mounting brackets cannot be mounted on the head side because a tapped hole is not on the side.

# Discontinued

Type Stroke Code	Standard cylinder (JCDA)			Cylinder with magnet (JCDAS)			K	JCDA				JCDAS		O
	A	B	C	A	B	C		5		10 or more		N <sub>1</sub>	N <sub>2</sub>	
								N <sub>1</sub>	N <sub>2</sub>	N <sub>1</sub>	N <sub>2</sub>			
32 [1.260]	38	15	23	48	15	33	M8×1.25 Depth13	10	6	11	8	11	8	Rc1/8
40 [1.575]	46.5	17	29.5	56.5	17	39.5	M8×1.25 Depth13	10	10	11.5	11.5	11.5	11.5	Rc1/8
50 [1.969]	48.5	18	30.5	58.5	18	40.5	M10×1.5 Depth15	—	—	12	12	12	12	Rc1/4
63 [2.480]	54	18	36	64	18	46	M10×1.5 Depth15	—	—	14.5	14.5	14.5	14.5	Rc1/4
80 [3.150]	69.5	26	43.5	79.5	26	53.5	M16×2 Depth21	—	—	16.5	16.5	16.5	16.5	Rc3/8
100 [3.940]	81	28	53	91	28	63	M20×2.5 Depth27	—	—	21	21	21	21	Rc3/8

Code	P						R	S	T	U	V	W	X	Y	BB		
32 [1.260]	Counterbore φ 9		Depth 5.4 (Both sides)		M 6×1		Depth from main body end 17.4 (Rod side)		4.5	45	34	R30	16	14	17.4	15	8
40 [1.575]	Counterbore φ 9		Depth 5.4 (Both sides)		M 6×1		Depth from main body end 17.4 (Rod side)		5	52	40	R34.5	16	14	20.5	17.5	10
50 [1.969]	Counterbore φ 11		Depth 8 (Both sides)		M 8×1.25		Depth from main body end 22 (Rod side)		7	64	50	R42.5	20	17	21.6	19	10
63 [2.480]	Counterbore φ 14		Depth 10.5 (Both sides)		M10×1.5		Depth from main body end 28.5 (Rod side)		7	77	60	R51	20	17	21.6	19	10
80 [3.150]	Counterbore φ 17.5		Depth 13.5 (Both sides)		M12×1.75		Depth from main body end 35.5 (Rod side)		6	98	77	R65	25	22	27.6	25	16
100 [3.940]	Counterbore φ 17.5		Depth 13.5 (Both sides)		M12×1.75		Depth from main body end 35.5 (Rod side)		6.5	117	94	R78	30	27	27.6	25	16

Type Code	BC	BD	BE	BF	BH	BP	BQ	BR	JCDA BS	JCDAS BS	BZ
32 [1.260]	48	33	72	58	7	7	51	3	31	41	4
40 [1.575]	56	36	84	70	7	7	59	3	39.5	49.5	4
50 [1.969]	70	47	104	86	8	9	74	4	40.5	50.5	5
63 [2.480]	84	56	116	98	8	9	87.5	3.5	46	56	6
80 [3.150]	105	70	150	126	10	12	107.5	2.5	59.5	69.5	8
100 [3.940]	121	84	165	143	12	12	125.5	4.5	69	79	8

# Dimensions of Standard Cylinder Double Acting Type (mm)

● Head side flange mounting type JCDA □ Bore size × Stroke -5

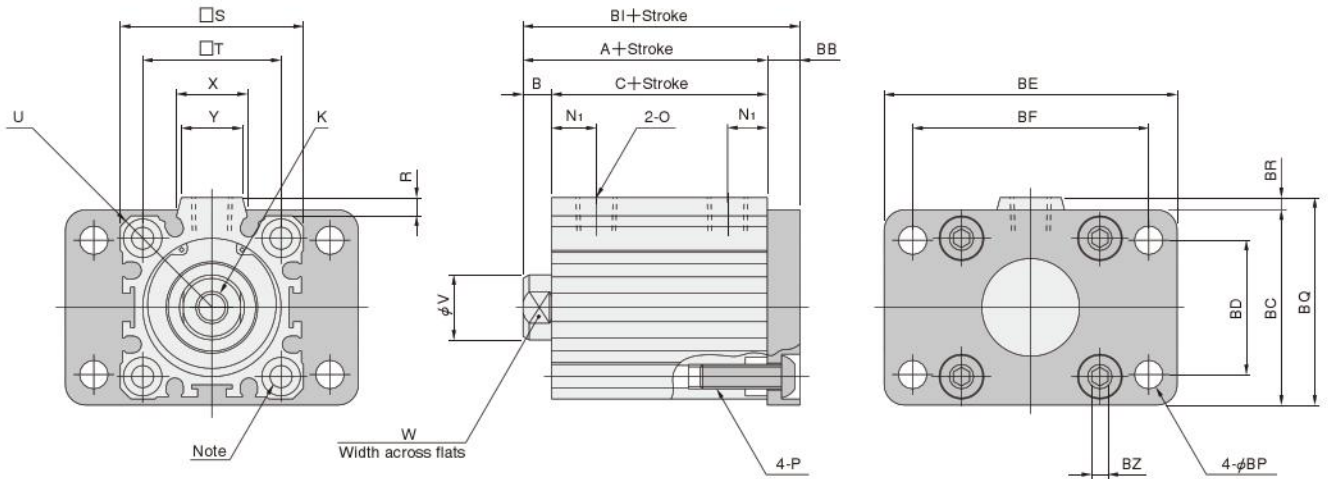

Note: The flange mounting brackets cannot be mounted on the rod side because a tapped hole is not on the side.

Discontinued

Type Stroke Code	Standard cylinder (JCDA)			Cylinder with magnet (JCDA S)			K	JCDA				JCDA S		O
	A	B	C	A	B	C		5		10 or more		N <sub>1</sub>	N <sub>2</sub>	
								N <sub>1</sub>	N <sub>2</sub>	N <sub>1</sub>	N <sub>2</sub>			
32 [1.260]	30	7	23	40	7	33	M8×1.25 Depth13	10	6	11	8	11	8	Rc1/8
40 [1.575]	36.5	7	29.5	46.5	7	39.5	M8×1.25 Depth13	10	10	11.5	11.5	11.5	11.5	Rc1/8
50 [1.969]	38.5	8	30.5	48.5	8	40.5	M10×1.5 Depth15	—	—	12	12	12	12	Rc1/4
63 [2.480]	44	8	36	54	8	46	M10×1.5 Depth15	—	—	14.5	14.5	14.5	14.5	Rc1/4
80 [3.150]	53.5	10	43.5	63.5	10	53.5	M16×2 Depth21	—	—	16.5	16.5	16.5	16.5	Rc3/8
100 [3.940]	65	12	53	75	12	63	M20×2.5 Depth27	—	—	21	21	21	21	Rc3/8

Code	P						R	S	T	U	V	W	X	Y	BB				
32 [1.260]	Counterbore φ 9	Depth 5.4 (Both sides)	M 6X1	Depth from main body end 17.4 (Head side)							4.5	45	34	R30	16	14	17.4	15	8
40 [1.575]	Counterbore φ 9	Depth 5.4 (Both sides)	M 6X1	Depth from main body end 17.4 (Head side)							5	52	40	R34.5	16	14	20.5	17.5	10
50 [1.969]	Counterbore φ 11	Depth 8 (Both sides)	M 8X1.25	Depth from main body end 22 (Head side)							7	64	50	R42.5	20	17	21.6	19	10
63 [2.480]	Counterbore φ 14	Depth 10.5 (Both sides)	M10X1.5	Depth from main body end 28.5 (Head side)							7	77	60	R51	20	17	21.6	19	10
80 [3.150]	Counterbore φ 17.5	Depth 13.5 (Both sides)	M12X1.75	Depth from main body end 35.5 (Head side)							6	98	77	R65	25	22	27.6	25	16
100 [3.940]	Counterbore φ 17.5	Depth 13.5 (Both sides)	M12X1.75	Depth from main body end 35.5 (Head side)							6.5	117	94	R78	30	27	27.6	25	16

Type Code	BC	BD	BE	BF	JCDA	JCDA S	BP	BQ	BR	BZ
					BI	BI				
32 [1.260]	48	33	72	58	38	48	7	51	3	4
40 [1.575]	56	36	84	70	46.5	56.5	7	59	3	4
50 [1.969]	70	47	104	86	48.5	58.5	9	74	4	5
63 [2.480]	84	56	116	98	54	64	9	87.5	3.5	6
80 [3.150]	105	70	150	126	69.5	79.5	12	107.5	2.5	8
100 [3.940]	121	84	165	143	81	91	12	125.5	4.5	8

# Dimensions of Standard Cylinder Single Acting Push Type (mm)

● Basic type JCSA □ Bore size × Stroke (φ 20, φ 25)

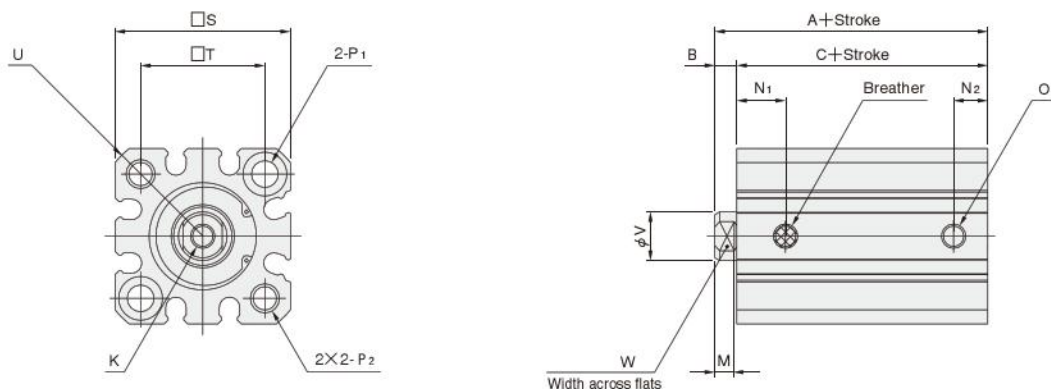

● Basic type JCSA □ Bore size × Stroke (φ 32~φ 50)

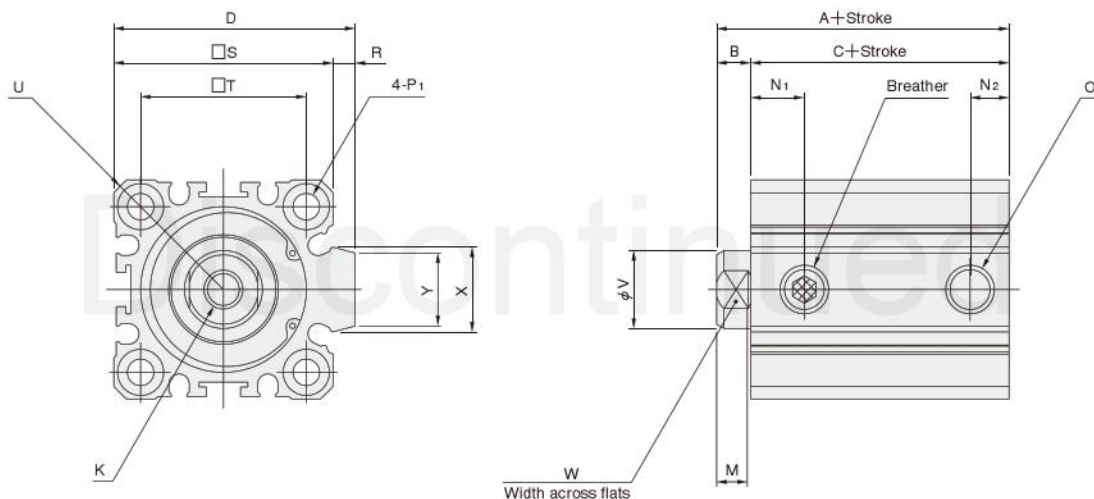

Type Stroke	Standard cylinder (JCSA)						Cylinder with magnet (JCSAS)						D	K	M	JCSA			
	5~10 (φ 50:10~20)			15~30 (φ 40:15~50, φ 50:25~50)			5~10 (φ 50:10~20)			15~30 (φ 40:15~50, φ 50:25~50)						5		10 or more	
	A	B	C	A	B	C	A	B	C	A	B	C				N <sub>1</sub>	N <sub>2</sub>	N <sub>1</sub>	N <sub>2</sub>
20 [0.787]	26	4.5	21.5	31	4.5	26.5	36	4.5	31.5	41	4.5	36.5	—	M5×0.8 Depth7	4	9	6	10	7
25 [0.984]	27.5	5	22.5	32.5	5	27.5	37.5	5	32.5	42.5	5	37.5	—	M6×1 Depth12	4.5	9	6	10	7
32 [1.260]	30	7	23	40	7	33	40	7	33	50	7	43	49.5	M8×1.25 Depth13	6.5	10	6	11	8
40 [1.575]	36.5	7	29.5	46.5	7	39.5	46.5	7	39.5	56.5	7	49.5	57	M8×1.25 Depth13	6.5	10	10	11.5	11.5
50 [1.969]	38.5	8	30.5	48.5	8	40.5	48.5	8	40.5	58.5	8	50.5	71	M10×1.5 Depth15	7	—	—	12	12

Type Bore mm (in)	JCSAS		O	P <sub>1</sub>			P <sub>2</sub>	R	S	T	U	V	W	X	Y
	N <sub>1</sub>	N <sub>2</sub>		φ	Counterbore	φ									
20 [0.787]	10	7	M5×0.8	φ 5.5 (Through hole)	Counterbore	φ 9 Depth5.4 (Both sides)	M6×1 Depth 10	—	36	25.5	R23.5	10	8	—	—
25 [0.984]	10	7	M5×0.8	φ 5.5 (Through hole)	Counterbore	φ 9 Depth5.4 (Both sides)	M6×1 Depth 10	—	40	28	R26	12	10	—	—
32 [1.260]	11	8	Rc1/8	φ 5.5 (Through hole)	Counterbore	φ 9 Depth5.4 (Both sides)	—	4.5	45	34	R30	16	14	17.4	15
40 [1.575]	11.5	11.5	Rc1/8	φ 5.5 (Through hole)	Counterbore	φ 9 Depth5.4 (Both sides)	—	5	52	40	R34.5	16	14	20.5	17.5
50 [1.969]	12	12	Rc1/4	φ 6.6 (Through hole)	Counterbore	φ 11 Depth8 (Both sides)	—	7	64	50	R42.5	20	17	21.6	19

# Dimensions of Standard Cylinder Single Acting Push Type (mm)

● Foot mounting type JCSA □ Bore size × Stroke -1

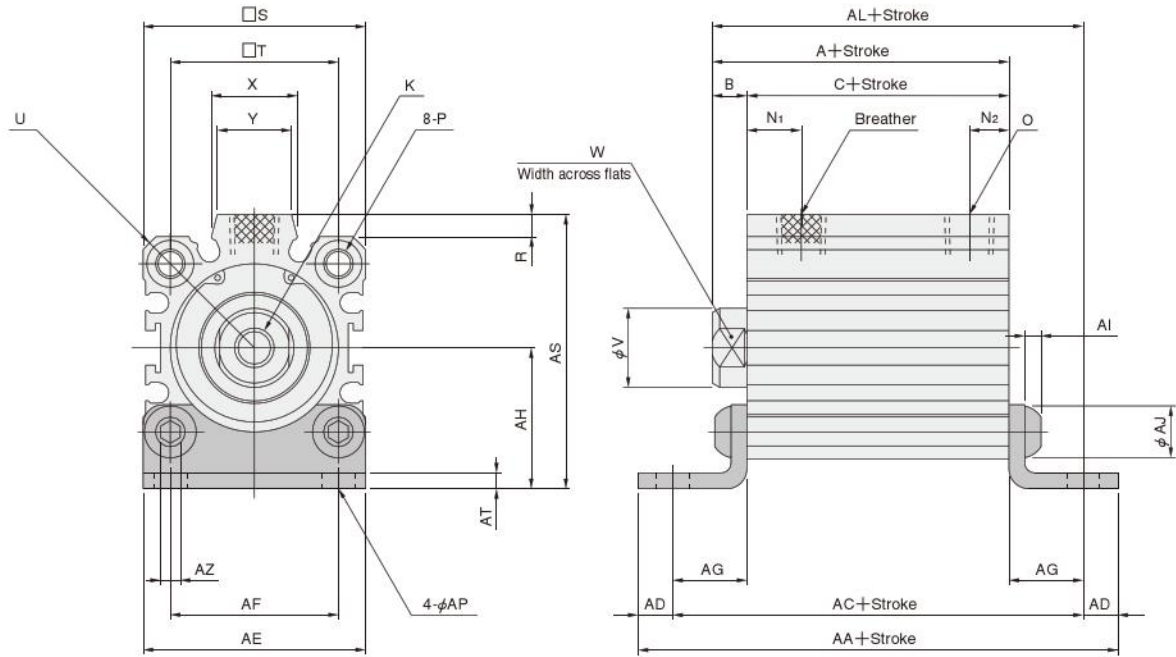

Discontinued

Type Stroke Code	Standard cylinder (JCSA)						Cylinder with magnet (JCSAS)						K	JCSA				JCSAS	
	5~10 <sup>Note 1</sup>			15~30 <sup>Note 2</sup>			5~10 <sup>Note 1</sup>			15~30 <sup>Note 2</sup>				5		10 or more		N <sub>1</sub>	N <sub>2</sub>
	A	B	C	A	B	C	A	B	C	A	B	C		N <sub>1</sub>	N <sub>2</sub>	N <sub>1</sub>	N <sub>2</sub>		
32 [1.260]	30	7	23	40	7	33	40	7	33	50	7	43	M8X1.25 Depth13	10	6	11	8	11	8
40 [1.575]	36.5	7	29.5	46.5	7	39.5	46.5	7	39.5	56.5	7	49.5	M8X1.25 Depth13	10	10	11.5	11.5	11.5	11.5
50 [1.969]	38.5	8	30.5	48.5	8	40.5	48.5	8	40.5	58.5	8	50.5	M10X1.5 Depth15	—	—	12	12	12	12

Type Stroke Code	O	P	R	S	T	U	V	W	X	Y	JCSA		JCSAS	
											5~10 <sup>Note 1</sup>	15~30 <sup>Note 2</sup>	5~10 <sup>Note 1</sup>	15~30 <sup>Note 2</sup>
											AA	AA	AA	AA
32 [1.260]	Rc1/8	Counterbore φ 9 Depth 5.4 (Both sides), M 6X1 Depth from main body end 17.4 (Both sides)	4.5	45	34	R30	16	14	17.4	15	67	77	77	87
40 [1.575]	Rc1/8	Counterbore φ 9 Depth 5.4 (Both sides), M 6X1 Depth from main body end 17.4 (Both sides)	5	52	40	R34.5	16	14	20.5	17.5	73.5	83.5	83.5	93.5
50 [1.969]	Rc1/4	Counterbore φ 11 Depth 8 (Both sides), M 8X1.25 Depth from main body end 22 (Both sides)	7	64	50	R42.5	20	17	21.6	19	84.5	94.5	94.5	104.5

Type Stroke Code	JCSA		JCSAS		AD	AE	AF	AG	AH	AI	AJ	JCSA		JCSAS		AP	AS	AT	AZ
	5~10 <sup>Note 1</sup>	15~30 <sup>Note 2</sup>	5~10 <sup>Note 1</sup>	15~30 <sup>Note 2</sup>								5~10 <sup>Note 1</sup>	15~30 <sup>Note 2</sup>	5~10 <sup>Note 1</sup>	15~30 <sup>Note 2</sup>				
	AC	AC	AC	AC								AL	AL	AL	AL				
32 [1.260]	53	63	63	73	7	45	34	15	28.5	4	10.5	45	55	55	65	6.6	55.5	3.2	4
40 [1.575]	59.5	69.5	69.5	79.5	7	53	40	15	32.5	4	10.5	51.5	61.5	61.5	71.5	6.6	63.5	3.2	4
50 [1.969]	66.5	76.5	76.5	86.5	9	64	50	18	38	5	14	56.5	66.5	66.5	76.5	9	77	3.2	5

Notes : 1. φ 50: 10~20.  
2. φ 40: 15~50, φ 50: 25~50.

# Dimensions of Standard Cylinder Single Acting Push Type (mm)

● Axial foot mounting type JCSA □ Bore size × Stroke -2

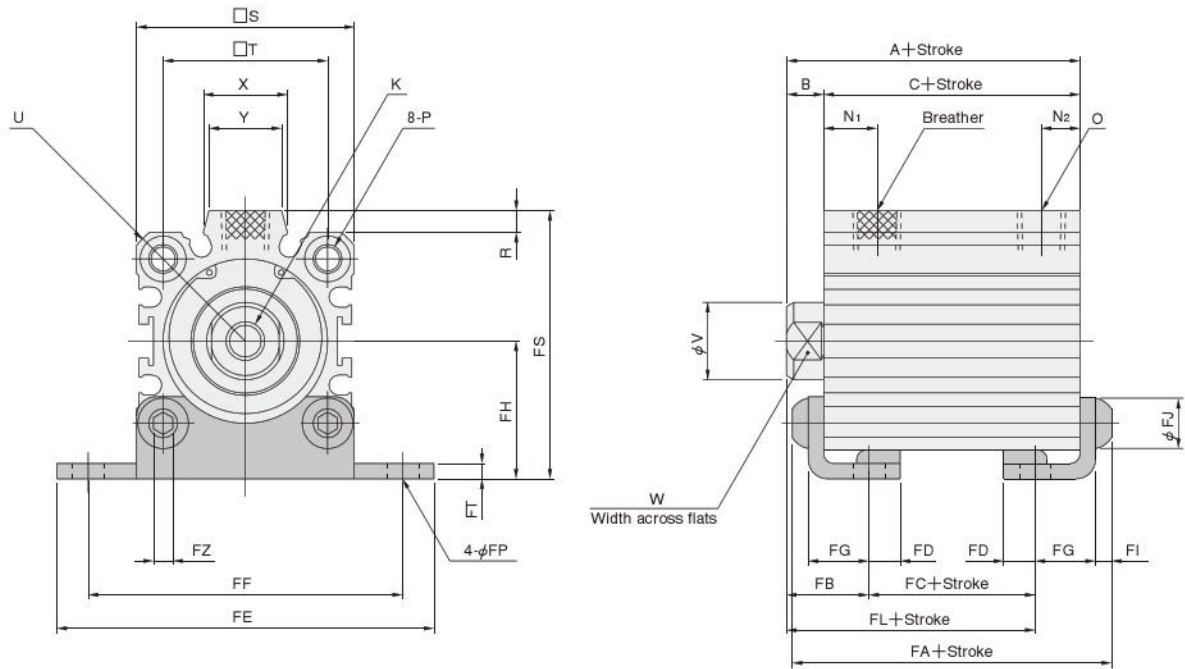

JIG CYLINDERS JC SERIES

Discontinued

Type Stroke Code	Standard cylinder (JCSA)						Cylinder with magnet (JCSAS)						K	JCSA				JCSAS	
	5~10 <sup>Note 1</sup>			15~30 <sup>Note 2</sup>			5~10 <sup>Note 1</sup>			15~30 <sup>Note 2</sup>				5		10 or more		N <sub>1</sub>	N <sub>2</sub>
	A	B	C	A	B	C	A	B	C	A	B	C		N <sub>1</sub>	N <sub>2</sub>	N <sub>1</sub>	N <sub>2</sub>		
32 [1.260]	30	7	23	40	7	33	40	7	33	50	7	43	M8X1.25 Depth13	—	—	11	8	11	8
40 [1.575]	36.5	7	29.5	46.5	7	39.5	46.5	7	39.5	56.5	7	49.5	M8X1.25 Depth13	10	10	11.5	11.5	11.5	11.5
50 [1.969]	38.5	8	30.5	48.5	8	40.5	48.5	8	40.5	58.5	8	50.5	M10X1.5 Depth15	—	—	12	12	12	12

Type Stroke Code	O	P	R	S	T	U	V	W	X	Y	JCSA		JCSAS					
											5~10 <sup>Note 1</sup>		15~30 <sup>Note 2</sup>		5~10 <sup>Note 1</sup>		15~30 <sup>Note 2</sup>	
											FA	FA	FA	FA				
32 [1.260]	Rc1/8	Counterbore φ 9 Depth 5.4 (Both sides), M 6X1 Depth from main body end 17.4 (Both sides)	4.5	45	34	R30	16	14	17.4	15	37.4	47.4	47.4	57.4				
40 [1.575]	Rc1/8	Counterbore φ 9 Depth 5.4 (Both sides), M 6X1 Depth from main body end 17.4 (Both sides)	5	52	40	R34.5	16	14	20.5	17.5	43.9	53.9	53.9	63.9				
50 [1.969]	Rc1/4	Counterbore φ 11 Depth 8 (Both sides), M 8X1.25 Depth from main body end 22 (Both sides)	7	64	50	R42.5	20	17	21.6	19	46.9	56.9	56.9	66.9				

Type Stroke Code	FB	JCSA		JCSAS		FD	FE	FF	FG	FH	FI	FJ	JCSA		JCSAS		FP	FS	FT	FZ
		5~10 <sup>Note 1</sup>		15~30 <sup>Note 2</sup>									5~10 <sup>Note 1</sup>		15~30 <sup>Note 2</sup>					
		FC	FC	FC	FC								FL	FL	FL	FL				
32 [1.260]	16.3	4.4	14.4	14.4	24.4	6.5	78	65	12.5	28.5	4	10.5	20.7	30.7	30.7	40.7	6.6	55.5	3.2	4
40 [1.575]	16.3	10.9	20.9	20.9	30.9	6.5	87	73	12.5	32.5	4	10.5	27.2	37.2	37.2	47.2	6.6	63.5	3.2	4
50 [1.969]	18.8	8.9	18.9	18.9	28.9	8	103	87	14	38	5	14	27.7	37.7	37.7	47.7	9	77	3.2	5

Notes : 1. φ 50: 10~20.

2. φ 40: 15~50, φ 50: 25~50.

Remark: Not available for JCSA32X5. (The mounting brackets cause interference unless the stroke is 10mm or more.)

# Dimensions of Standard Cylinder Single Acting Push Type (mm)

● Rod side flange mounting type JCSA □ Bore size × Stroke -3

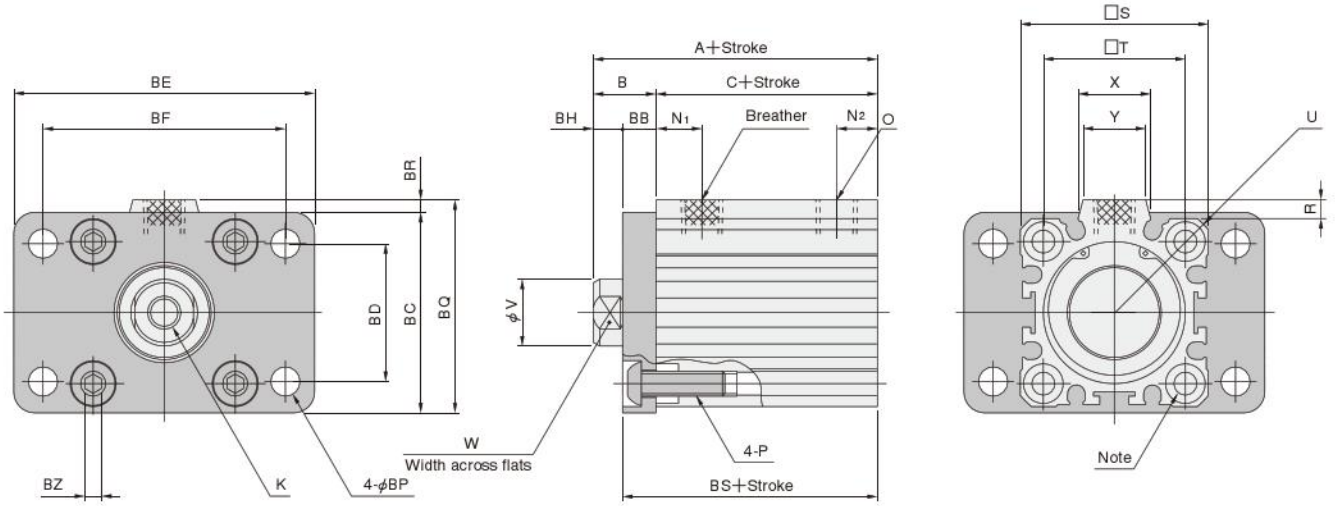

Note: The flange mounting brackets cannot be mounted on the head side because a tapped hole is not on the side.

Discontinued

Type Stroke	Standard cylinder (JCSA)						Cylinder with magnet (JCSAS)						K	JCSA				JCSAS	
	5~10 <sup>Note 1</sup>			15~30 <sup>Note 2</sup>			5~10 <sup>Note 1</sup>			15~30 <sup>Note 2</sup>				5		10 or more		N <sub>1</sub>	N <sub>2</sub>
	A	B	C	A	B	C	A	B	C	A	B	C		N <sub>1</sub>	N <sub>2</sub>	N <sub>1</sub>	N <sub>2</sub>		
32 [1.260]	38	7	23	48	7	33	48	7	33	58	7	43	M8X1.25 Depth13	10	6	11	8	11	8
40 [1.575]	46.5	7	29.5	56.5	7	39.5	56.5	7	39.5	66.5	7	49.5	M8X1.25 Depth13	10	10	11.5	11.5	11.5	11.5
50 [1.969]	48.5	8	30.5	58.5	8	40.5	58.5	8	40.5	68.5	8	50.5	M10X1.5 Depth15	—	—	12	12	12	12

Bore mm [in.]	Code	O	P					R	S	T	U	V	W	X	Y	BB
32 [1.260]	Rc1/8	Counterbore φ 9 Depth 5.4 (Both sides), M 6X1 Depth from main body end 17.4 (Rod side)	4.5	45	34	R30	16	14	17.4	15	8					
40 [1.575]	Rc1/8	Counterbore φ 9 Depth 5.4 (Both sides), M 6X1 Depth from main body end 17.4 (Rod side)	5	52	40	R34.5	16	14	20.5	17.5	10					
50 [1.969]	Rc1/4	Counterbore φ 11 Depth 8 (Both sides), M 8X1.25 Depth from main body end 22 (Rod side)	7	64	50	R42.5	20	17	21.6	19	10					

Type Stroke	Code	BC	BD	BE	BF	BH	BP	BQ	BR	JCSA		JCSAS		BZ
										5~10 <sup>Note 1</sup>	15~30 <sup>Note 2</sup>	5~10 <sup>Note 1</sup>	15~30 <sup>Note 2</sup>	
										BS	BS	BS	BS	
32 [1.260]		48	33	72	58	7	7	51	3	31	41	41	51	4
40 [1.575]		56	36	84	70	7	7	59	3	39.5	49.5	49.5	59.5	4
50 [1.969]		70	47	104	86	8	9	74	4	40.5	50.5	50.5	60.5	5

Notes : 1. φ 50: 10~20.  
2. φ 40: 15~50, φ 50: 25~50.

# Dimensions of Standard Cylinder Single Acting Push Type (mm)

● Head side flange mounting type JCSA □ Bore size × Stroke -5

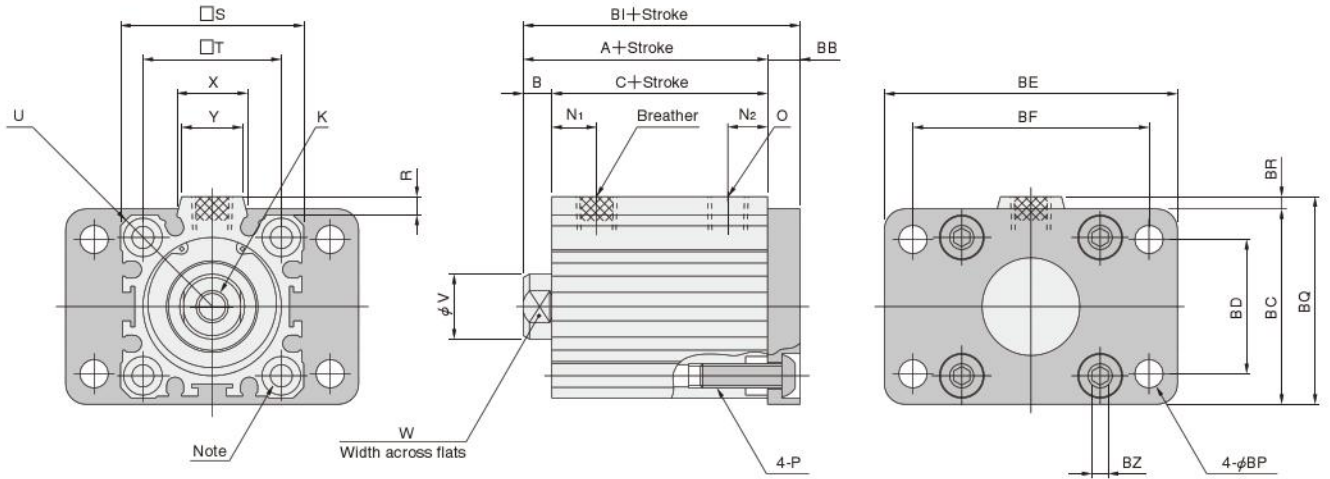

Note: The flange mounting brackets cannot be mounted on the rod side because a tapped hole is not on the side.

JIG CYLINDERS JC SERIES

Discontinued

Type Stroke	Standard cylinder (JCSA)						Cylinder with magnet (JCSAS)						K	JCSA				JCSAS	
	5~10 <sup>Note 1</sup>			15~30 <sup>Note 2</sup>			5~10 <sup>Note 1</sup>			15~30 <sup>Note 2</sup>				5		10 or more		N <sub>1</sub>	N <sub>2</sub>
	A	B	C	A	B	C	A	B	C	A	B	C		N <sub>1</sub>	N <sub>2</sub>	N <sub>1</sub>	N <sub>2</sub>		
<b>32 [1.260]</b>	30	7	23	40	7	33	40	7	33	50	7	43	M8X1.25 Depth13	10	6	11	8	11	8
<b>40 [1.575]</b>	36.5	7	29.5	46.5	7	39.5	46.5	7	39.5	56.5	7	49.5	M8X1.25 Depth13	10	10	11.5	11.5	11.5	11.5
<b>50 [1.969]</b>	38.5	8	30.5	48.5	8	40.5	48.5	8	40.5	58.5	8	50.5	M10X1.5 Depth15	—	—	12	12	12	12

Bore mm [in.]	Code	O	P					R	S	T	U	V	W	X	Y	BB	BC	BD
<b>32 [1.260]</b>	Rc1/8	Counterbore φ 9 Depth 5.4 (Both sides), M 6X1 Depth from main body end 17.4 (Head side)	4.5	45	34	R30	16	14	17.4	15	8	48	33					
<b>40 [1.575]</b>	Rc1/8	Counterbore φ 9 Depth 5.4 (Both sides), M 6X1 Depth from main body end 17.4 (Head side)	5	52	40	R34.5	16	14	20.5	17.5	10	56	36					
<b>50 [1.969]</b>	Rc1/4	Counterbore φ 11 Depth 8 (Both sides), M 8X1.25 Depth from main body end 22 (Head side)	7	64	50	R42.5	20	17	21.6	19	10	70	47					

Type Stroke	BE	BF	JCSA		JCSAS		BP	BQ	BR	BZ
			5~10 <sup>Note 1</sup>	15~30 <sup>Note 2</sup>	5~10 <sup>Note 1</sup>	15~30 <sup>Note 2</sup>				
			BI	BI	BI	BI				
<b>32 [1.260]</b>	72	58	38	48	48	58	7	51	3	4
<b>40 [1.575]</b>	84	70	46.5	56.5	56.5	66.5	7	59	3	4
<b>50 [1.969]</b>	104	88	48.5	58.5	58.5	68.5	9	74	4	5

Notes : 1. φ 50: 10~20.  
2. φ 40: 15~50, φ 50: 25~50.

# Dimensions of Standard Cylinder Single Acting Pull Type (mm)

● Basic type JCTA **Bore size** × **Stroke** ( $\phi 20, \phi 25$ )

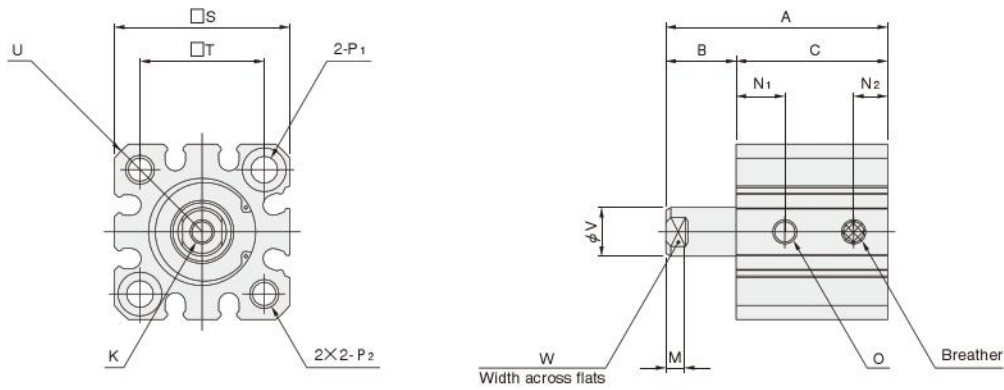

● Basic type JCTA **Bore size** × **Stroke** ( $\phi 32 \sim \phi 50$ )

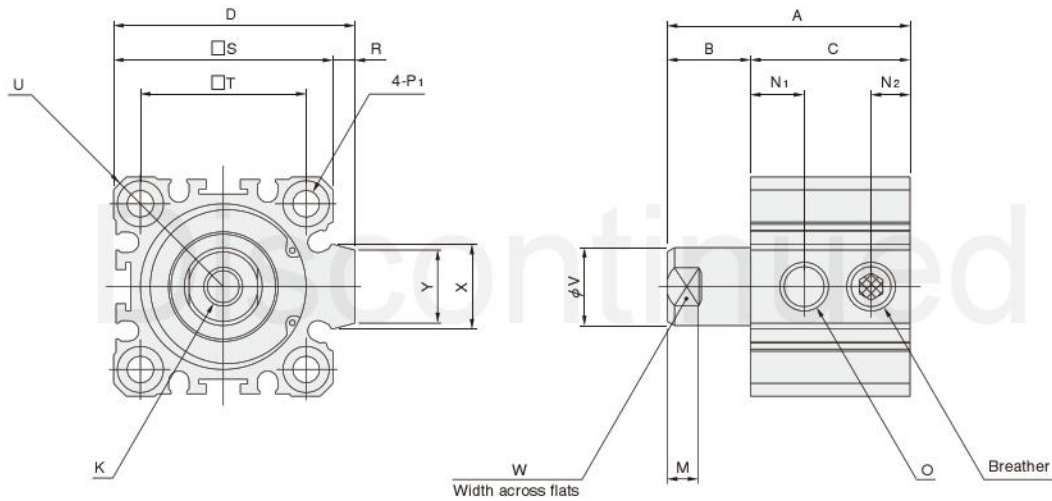

Stroke mm [in.]	5			10			20			D	K	M	5		10 or more	
	A	B	C	A	B	C	A	B	C				N <sub>1</sub>	N <sub>2</sub>	N <sub>1</sub>	N <sub>2</sub>
20 [0.787]	36	9.5	26.5	46	14.5	31.5	—	—	—	—	M5×0.8 Depth 7	4	9	6	10	7
25 [0.984]	37.5	10	27.5	47.5	15	32.5	—	—	—	—	M6×1 Depth 12	4.5	9	6	10	7
32 [1.260]	40	12	28	50	17	33	—	—	—	49.5	M8×1.25 Depth 13	6.5	10	6	11	8
40 [1.575]	46.5	12	34.5	56.5	17	39.5	—	—	—	57	M8×1.25 Depth 13	6.5	10	10	11.5	11.5
50 [1.969]	—	—	—	58.5	18	40.5	78.5	28	50.5	71	M10×1.5 Depth 15	7	—	—	12	12

Code	Bore mm [in.]	O	P <sub>1</sub>		P <sub>2</sub>	R	S	T	U	V	W	X	Y
			Through hole	Counterbore									
20 [0.787]	M5×0.8	$\phi 5.5$ (Through hole)	Counterbore $\phi 9$	Depth 5.4 (Both sides)	M6×1 Depth 10	—	36	25.5	R23.5	10	8	—	—
25 [0.984]	M5×0.8	$\phi 5.5$ (Through hole)	Counterbore $\phi 9$	Depth 5.4 (Both sides)	M6×1 Depth 10	—	40	28	R26	12	10	—	—
32 [1.260]	Rc1/8	$\phi 5.5$ (Through hole)	Counterbore $\phi 9$	Depth 5.4 (Both sides)	—	4.5	45	34	R30	16	14	17.4	15
40 [1.575]	Rc1/8	$\phi 5.5$ (Through hole)	Counterbore $\phi 9$	Depth 5.4 (Both sides)	—	5	52	40	R34.5	16	14	20.5	17.5
50 [1.969]	Rc1/4	$\phi 6.6$ (Through hole)	Counterbore $\phi 11$	Depth 8 (Both sides)	—	7	64	50	R42.5	20	17	21.6	19

# Dimensions of Standard Cylinder Single Acting Pull Type (mm)

● Foot mounting type JCTA Bore size × Stroke -1

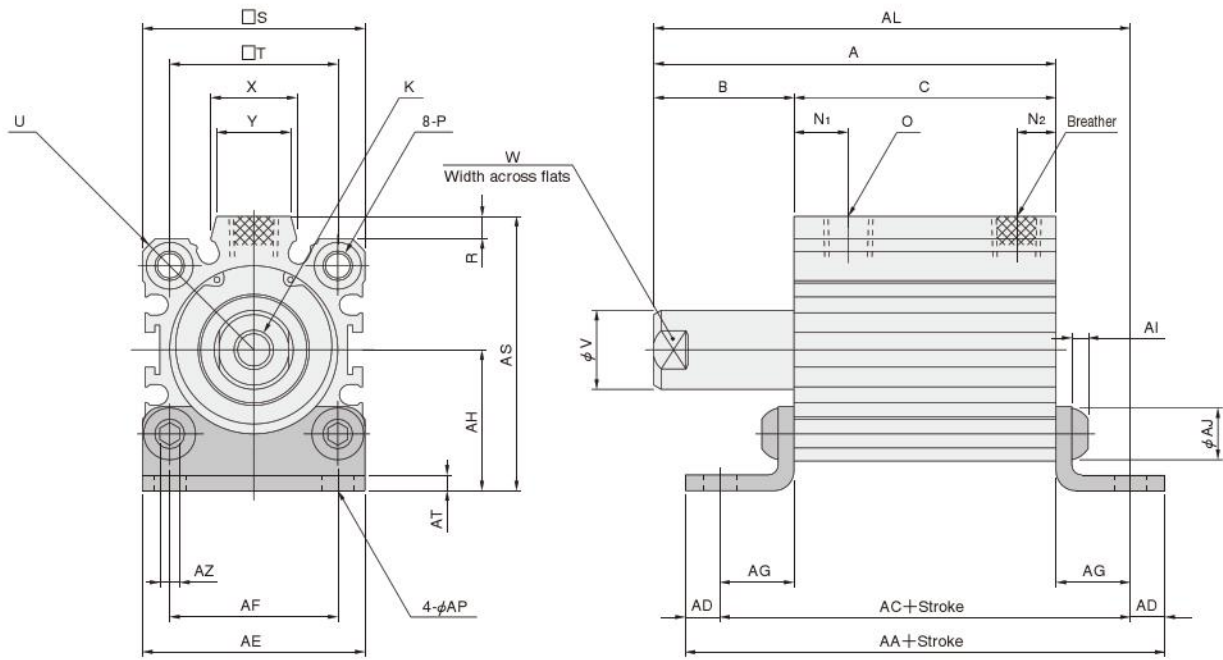

Discontinued

Stroke Code	5			10			20			K	5		10 or more		O
	A	B	C	A	B	C	A	B	C		N <sub>1</sub>	N <sub>2</sub>	N <sub>1</sub>	N <sub>2</sub>	
32 [1.260]	40	12	28	50	17	33	—	—	—	M8×1.25 Depth13	10	6	11	8	Rc1/8
40 [1.575]	46.5	12	34.5	56.5	17	39.5	—	—	—	M8×1.25 Depth13	10	10	11.5	11.5	Rc1/8
50 [1.969]	—	—	—	58.5	18	40.5	78.5	28	50.5	M10×1.5 Depth15	—	—	12	12	Rc1/4

Stroke Code	P	R	S	T	U	V	W	X	Y	5	10	20	5	10	20
										AA	AA	AA	AC	AC	AC
32 [1.260]	Counterbore φ 9 Depth 5.4 (Both sides), M 6×1 Depth from main body end 17.4 (Both sides)	4.5	45	34	R30	16	14	17.4	15	72	77	—	58	63	—
40 [1.575]	Counterbore φ 9 Depth 5.4 (Both sides), M 6×1 Depth from main body end 17.4 (Both sides)	5	52	40	R34.5	16	14	20.5	17.5	78.5	83.5	—	64.5	69.5	—
50 [1.969]	Counterbore φ 11 Depth 8 (Both sides), M 8×1.25 Depth from main body end 22 (Both sides)	7	64	50	R42.5	20	17	21.6	19	—	94.5	104.5	—	76.5	86.5

Stroke Code	AD	AE	AF	AG	AH	AI	AJ	5	10	20	AP	AS	AT	AZ
								AL	AL	AL				
32 [1.260]	7	45	34	15	28.5	4	10.5	55	65	—	6.6	55.5	3.2	4
40 [1.575]	7	53	40	15	32.5	4	10.5	61.5	71.5	—	6.6	63.5	3.2	4
50 [1.969]	9	64	50	18	38	5	14	—	76.5	96.5	9	77	3.2	5

JIG CYLINDERS JC SERIES

# Dimensions of Standard Cylinder Single Acting Pull Type (mm)

● Axial foot mounting type JCTA **Bore size** × **Stroke** -2

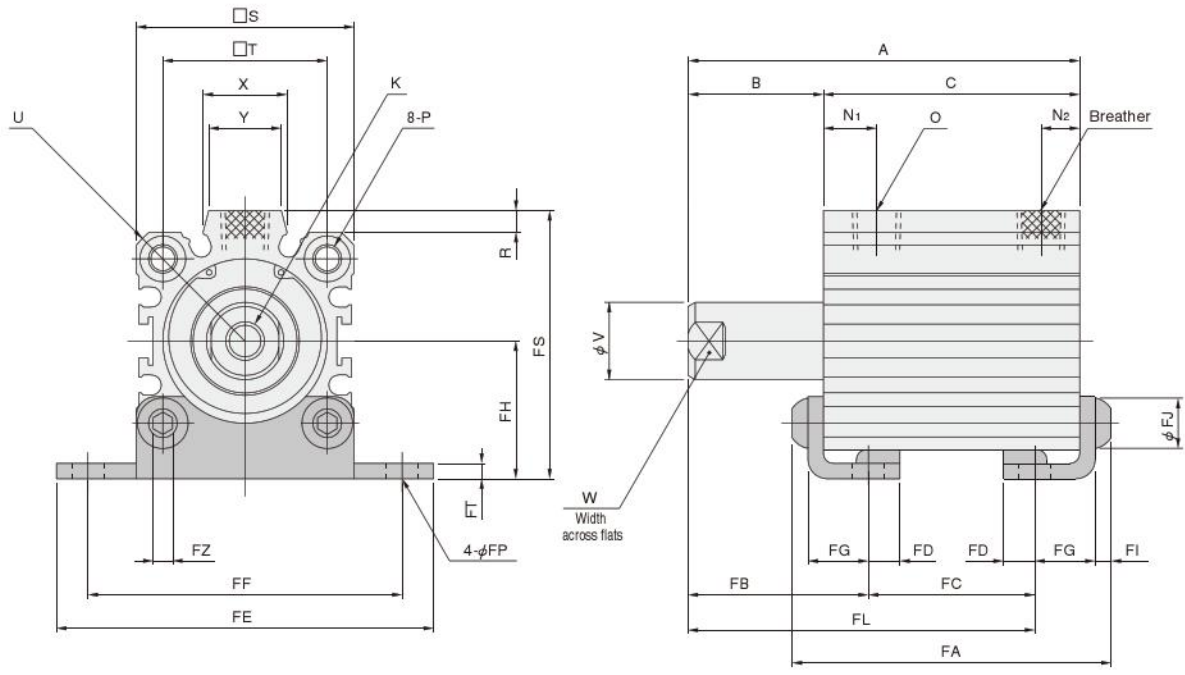

Discontinued

Stroke mm [in.]	5			10			20			K	5		10 or more		O
	A	B	C	A	B	C	A	B	C		N <sub>1</sub>	N <sub>2</sub>	N <sub>1</sub>	N <sub>2</sub>	
32 [1.260]	—	—	—	50	17	33	—	—	—	M8×1.25 Depth13	—	—	11	8	Rc1/8
40 [1.575]	46.5	12	34.5	56.5	17	39.5	—	—	—	M8×1.25 Depth13	10	10	11.5	11.5	Rc1/8
50 [1.969]	—	—	—	58.5	18	40.5	78.5	28	50.5	M10×1.5 Depth15	—	—	12	12	Rc1/4

Stroke mm [in.]	Code	P	R	S	T	U	V	W	X	Y	5	10	20	5	10	20
											FA	FA	FA	FB	FB	FB
32 [1.260]		Counterbore φ9 Depth 5.4 (Both sides), M 6×1 Depth from main body end 17.4 (Both sides)	4.5	45	34	R30	16	14	17.4	15	—	47.4	—	—	26.5	—
40 [1.575]		Counterbore φ9 Depth 5.4 (Both sides), M 6×1 Depth from main body end 17.4 (Both sides)	5	52	40	R34.5	16	14	20.5	17.5	48.9	53.9	—	21.5	26.5	—
50 [1.969]		Counterbore φ11 Depth 8 (Both sides), M 8×1.25 Depth from main body end 22 (Both sides)	7	64	50	R42.5	20	17	21.6	19	—	56.9	66.9	—	29	39

Stroke mm [in.]	Code	5	10	20	FD	FE	FF	FG	FH	FI	FJ	5	10	20	FP	FS	FT	FZ
		FC	FC	FC								FL	FL	FL				
32 [1.260]		—	14.4	—	6.5	78	65	12.5	28.5	4	10.5	—	40.7	—	6.6	55.5	3.2	4
40 [1.575]		15.9	20.9	—	6.5	87	73	12.5	32.5	4	10.5	37.2	47.2	—	6.6	63.5	3.2	4
50 [1.969]		—	18.9	28.9	8	103	87	14	38	5	14	—	47.7	67.7	9	77	3.2	5

Remark: Not available for JCTA32×5. (The mounting brackets cause interference unless the stroke is 10mm or more.)

# Dimensions of Standard Cylinder Single Acting Pull Type (mm)

● Rod side flange mounting type JCTA **Bore size** × **Stroke** -3

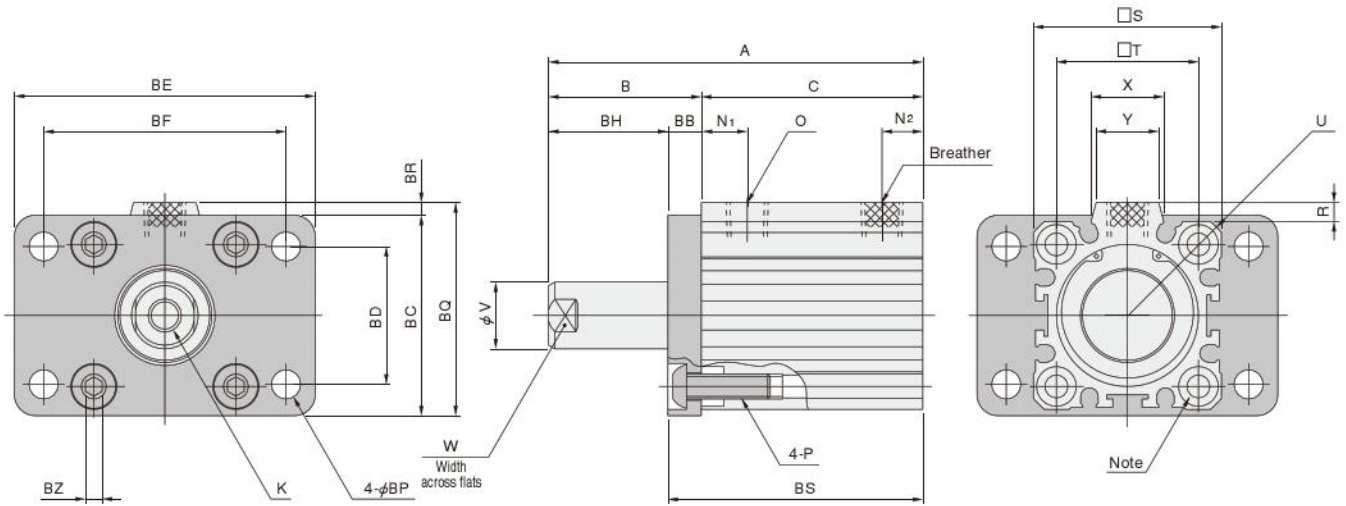

Note: The flange mounting brackets cannot be mounted on the head side because a tapped hole is not on the side.

Discontinued

Stroke Code	5			10			20			K	5		10 or more		O
	A	B	C	A	B	C	A	B	C		N <sub>1</sub>	N <sub>2</sub>	N <sub>1</sub>	N <sub>2</sub>	
32 [1.260]	48	20	28	58	25	33	—	—	—	M8×1.25 Depth13	10	6	11	8	Rc1/8
40 [1.575]	56.5	22	34.5	66.5	27	39.5	—	—	—	M8×1.25 Depth13	10	10	11.5	11.5	Rc1/8
50 [1.969]	—	—	—	68.5	28	40.5	88.5	38	50.5	M10×1.5 Depth15	—	—	12	12	Rc1/4

Stroke Code	P					R	S	T	U	V	W	X	Y	BB	BC	BD
32 [1.260]	Counterbore φ9 Depth 5.4 (Both sides), M6×1 Depth from main body end 17.4 (Rod side surface)					4.5	45	34	R30	16	14	17.4	15	8	48	33
40 [1.575]	Counterbore φ9 Depth 5.4 (Both sides), M6×1 Depth from main body end 17.4 (Rod side surface)					5	52	40	R34.5	16	14	20.5	17.5	10	56	36
50 [1.969]	Counterbore φ11 Depth 8 (Both sides), M8×1.25 Depth from main body end 22 (Rod side surface)					7	64	50	R42.5	20	17	21.6	19	10	70	47

Stroke Code	BE	BF	5	10	20	BP	BQ	BR	5	10	20	BZ
			BH	BH	BH				BS	BS	BS	
32 [1.260]	72	58	12	17	—	7	51	3	36	41	—	4
40 [1.575]	84	70	12	17	—	7	59	3	44.5	49.5	—	4
50 [1.969]	104	86	—	18	28	9	74	4	—	50.5	60.5	5

# Dimensions of Standard Cylinder Single Acting Pull Type (mm)

● Head side flange mounting type JCTA Bore size × Stroke -5

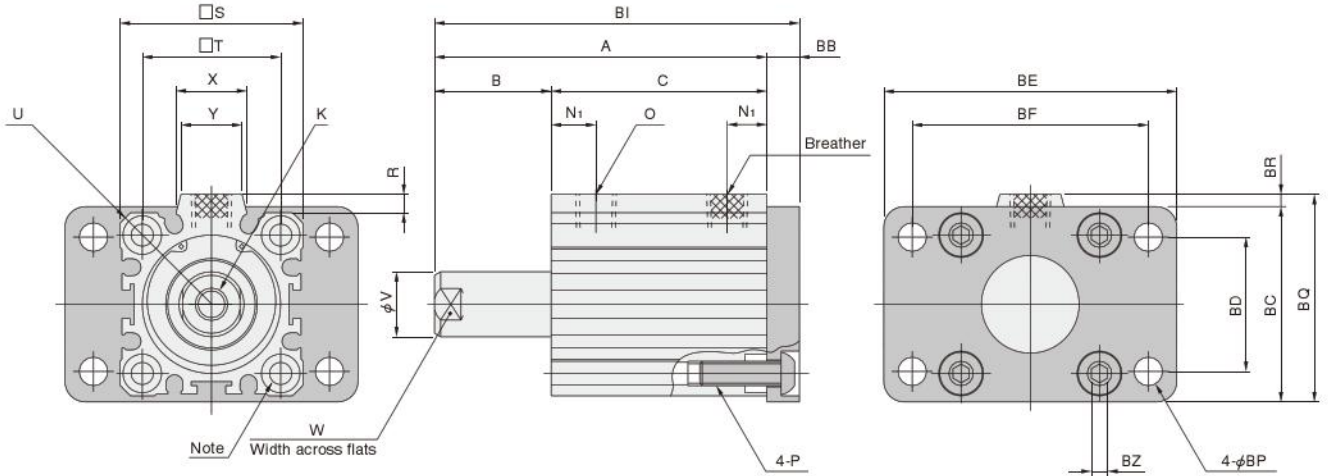

Note: The flange mounting brackets cannot be mounted on the rod side because a tapped hole is not on the side.

Stroke Bore mm [in.]	Code	5			10			20			K	5		10 or more		O
		A	B	C	A	B	C	A	B	C		N <sub>1</sub>	N <sub>2</sub>	N <sub>1</sub>	N <sub>2</sub>	
32	[1.260]	40	12	28	50	17	33	—	—	—	M8×1.25 Depth13	10	6	11	8	Rc1/8
40	[1.575]	46.5	12	34.5	56.5	17	39.5	—	—	—	M8×1.25 Depth13	10	10	11.5	11.5	Rc1/8
50	[1.969]	—	—	—	58.5	18	40.5	78.5	28	50.5	M10×1.5 Depth15	—	—	12	12	Rc1/4

Stroke Bore mm [in.]	Code	P				R	S	T	U	V	W	X	Y	BB	BC
		Counterbore φ 9 Depth 5.4 (Both sides), M 6 X 1 Depth from main body end 17.4 (Head side)						4.5	45	34	R30	16	14	17.4	15
Counterbore φ 9 Depth 5.4 (Both sides), M 6 X 1 Depth from main body end 17.4 (Head side)						5	52	40	R34.5	16	14	20.5	17.5	10	56
Counterbore φ 11 Depth 8 (Both sides), M 8 X 1.25 Depth from main body end 22 (Head side)						7	64	50	R42.5	20	17	21.6	19	10	70

Stroke Bore mm [in.]	Code	BD	BE	BF	5	10	20	BP	BQ	BR	BZ
					BI	BI	BI				
32	[1.260]	33	72	58	48	58	—	7	51	3	4
40	[1.575]	36	84	70	56.5	66.5	—	7	59	3	4
50	[1.969]	47	104	86	—	68.5	88.5	9	74	4	5

## With Double-sided Mounting Thread Dimensions (mm)

- Double acting type, Single acting push type, Single acting pull type JCDA □, JCSA □, JCTA □ Bore size × Stroke -13
- φ 32~φ 100 (single acting type is available up to φ 50.)

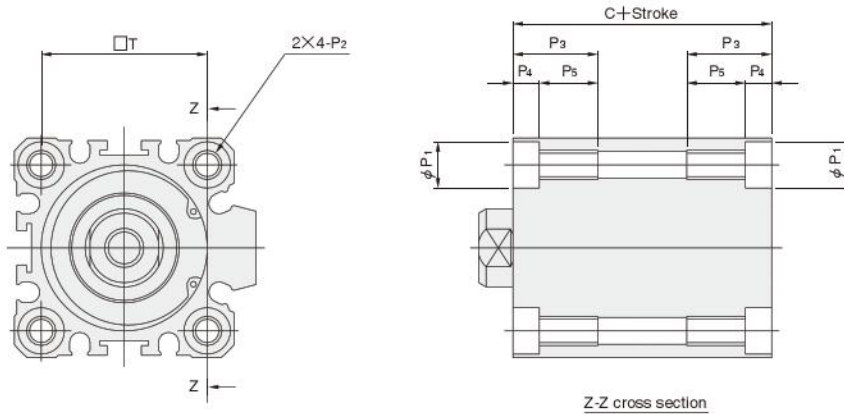

Bore mm [in.]	Code	P <sub>1</sub>	P <sub>2</sub>	P <sub>3</sub>	P <sub>4</sub>	P <sub>5</sub> Note	T
32 [1.260]		9	M6×1	17.4	5.4	12	34
40 [1.575]		9	M6×1	17.4	5.4	12	40
50 [1.969]		11	M8×1.25	22	8	14	50
63 [2.480]		14	M10×1.5	28.5	10.5	18	60
80 [3.150]		17.5	M12×1.75	35.5	13.5	22	77
100 [3.940]		17.5	M12×1.75	35.5	13.5	22	94

Note: When "C + Stroke" is less than the values shown below, the through thread is used.

Code	Bore mm [in.]	32 [1.260]	40 [1.575]	50 [1.969]	63 [2.480]	80 [3.150]	100 [3.940]
C+Stroke		38	39.5	45.5	61	73.5	73

- For dimensions not shown in this diagram, see the Standard Cylinder Basic Type.
- The single acting type is available up to φ 50.

## Dimensions of Male Rod End Thread Specification (mm)

- Double acting type, Single acting push type, Single acting pull type JCDA □, JCSA □, JCTA □ Bore size × Stroke -B
- φ 20~φ 100 (single acting type is available up to φ 50.)

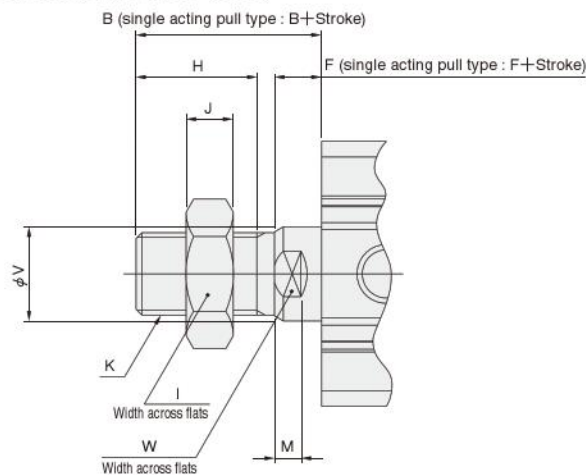

Bore mm [in.]	Code	B	F	H	I	J	K	M	V	W
20 [0.787]		18.5	4.5	12	13	5	M8×1.25	4	10	8
25 [0.984]		22.5	5	15	17	6	M10×1.25	4.5	12	10
32 [1.260]		28.5	5	20.5	22	8	M14×1.5	4.5	16	14
40 [1.575]		28.5	5	20.5	22	8	M14×1.5	4.5	16	14
50 [1.969]		33.5	5	25.5	24	11	M18×1.5	4	20	17
63 [2.480]		33.5	5	25.5	24	11	M18×1.5	4	20	17
80 [3.150]		43.5	8	32.5	30	13	M22×1.5	7	25	22
100 [3.940]		43.5	8	32.5	41	16	M26×1.5	7	30	27

- The single acting type is available up to φ 50.

Remark: Cylinder joints and cylinder rod ends are available for mounting with the rod end male thread specification. For details, see p.1568.

# JIG CYLINDERS JC SERIES

## Double Rod Cylinders Double Acting Type



### Symbol

● Double acting type

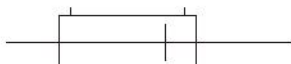

### Specifications

Item	Bore size mm [in.]	20 [0.787]	25 [0.984]	32 [1.260]	40 [1.575]	50 [1.969]	63 [2.480]	80 [3.150]	100 [3.940]	
Operation type		Double acting type								
Media		Air								
Mounting type		Basic type	Basic type, foot type, axial foot type, rod side flange type, with double-sided mounting thread							
Rod end specification		Female thread, male thread (optional)								
Operating pressure range <sup>Note 1</sup>	MPa [psi.]	0.1~1.0 [15~145]			0.05~1.0 [7~145]					
Proof pressure	MPa [psi.]	1.5 [218]								
Operating temperature range	°C [°F]	-10~70 [14~158] (0~60 [32~140] for with sensor) <sup>Note 2</sup>								
Operating speed range	mm/s [in./sec.]	30~500 [1.2~19.7]				30~300 [1.2~11.8]				
Cushion		Rubber bumper								
Lubrication		Not required (If lubrication is required, use Turbine Oil Class 1 (ISO VG32) or equivalent.)								
Port size		M5×0.8	Rc1/8		Rc1/4		Rc3/8			
Stroke tolerance	mm [in.]					+1 [ +0.039 ] 0 [ 0 ]				

Notes: 1. While the minimum operating pressure is included, the breakaway pressure is not included.

2. When using at temperature of -10~0°C [14~32°F], be careful to avoid freezing.

### Bore Size and Stroke

Bore size	Standard strokes	Maximum available stroke
20	5, 10, 15, 20, 25, 30	30
25		
32	5, 10, 15, 20, 25, 30, 35, 40, 45, 50	50
40		
50		
63	10, 15, 20, 25, 30, 35, 40, 45, 50	
80		
100		

Remark: The non-standard stroke (see p.213.) is set in increments of 1mm only. Consult us about delivery.

# Order Codes

## ● Double rod cylinders

**JC DA D** **40×50** - - - - -

**Jig Cylinders JC Series**

**Operation type**  
DA: Double acting type

**Double rod cylinders**

**Cylinder specification**  
Blank: Standard cylinder (Sensor switch non-compatible type)  
S: Cylinder with magnet

**Bore size × Stroke**<sup>Note 1</sup>

**Rod end specification**  
Blank: Female thread  
B: Male thread

**Mounting type**<sup>Note 2, 3</sup>  
Blank: Basic type (without double-sided mounting thread)  
1: Foot mounting type  
2: Axial foot mounting type  
3: Rod side flange mounting type  
13: With double-sided mounting thread

**Sensor switch type**<sup>Note 4</sup>  
Blank: No sensor switch  
ZE101: Reed switch type without indicator lamp, Horizontal lead wire DC5~28V, AC85~115V  
ZE102: Reed switch type with indicator lamp, Horizontal lead wire DC10~28V, AC85~115V  
ZE201: Reed switch type without indicator lamp, Vertical lead wire<sup>Note 5</sup> DC5~28V, AC85~115V  
ZE202: Reed switch type with indicator lamp, Vertical lead wire<sup>Note 5</sup> DC10~28V, AC85~115V  
ZE135: 2-lead wire Solid state type with indicator lamp, Horizontal lead wire DC10~28V  
ZE155: 3-lead wire Solid state type with indicator lamp, Horizontal lead wire DC4.5~28V  
ZE235: 2-lead wire Solid state type with indicator lamp, Vertical lead wire<sup>Note 5</sup> DC10~28V  
ZE255: 3-lead wire Solid state type with indicator lamp, Vertical lead wire<sup>Note 5</sup> DC4.5~28V  
ZD136: Strong magnetic field resistant sensor switch 2-lead wire Solid state type with indicator lamp, Horizontal lead wire DC10~28V

**Number of sensor switches**  
1: With 1 sensor switch  
2: With 2 sensor switches  
⋮  
n: With n sensor switches

**Lead wire length**<sup>Note 6</sup>  
A: 1000mm [39in.]  
B: 3000mm [118in.]  
C: 5000mm [197in.]

● For details of sensor switches, see p.246, 249.

Notes: 1. For the bore size and stroke, see p.237.  
2. Mounting brackets are available for  $\phi$  32 [1.260in.] to  $\phi$  100 [3.940in.] only.  
3. After purchasing the basic body type, it cannot thereafter be changed to the foot mounting type, the axial foot mounting type, the flange mounting type, or with double-sided mounting thread.  
4. ZD136 is available only for  $\phi$  32 [1.260in.] to  $\phi$  100 [3.940in.].  
5. The vertical lead wire type means the lead wire comes the sensor switch at perpendicular direction.  
6. A and B are available with the ZE type only, C is with the ZD type only.  
Remark: Cylinder joints and cylinder rod ends are available for mounting with the rod end male thread specification (excluding  $\phi$  20). For details, see p.1568.

## ● Mounting bracket only <sup>Note 1</sup>

**JCDA**

**Mounting bracket**  
1: Foot mounting type  
2: Axial foot mounting type  
3: Flange mounting type (common to both rod and head side)  
N: Rod end nut (for piston rod with male thread specification)

**Jig Cylinders JC Series**

**Bore size**  
20: For  $\phi$  20 [0.787in.]<sup>Note 2</sup>  
25: For  $\phi$  25 [0.984in.]<sup>Note 2</sup>  
32: For  $\phi$  32 [1.260in.]  
40: For  $\phi$  40 [1.575in.]  
50: For  $\phi$  50 [1.969in.]  
63: For  $\phi$  63 [2.480in.]  
80: For  $\phi$  80 [3.150in.]  
100: For  $\phi$  100 [3.940in.]

## ● Repair kit only

**SRK - JCDA**

**Repair kit**  
SRK: Repair kit 1 set

**Double rod double acting type**

**Bore size**  
20: For  $\phi$  20 [0.787in.]  
25: For  $\phi$  25 [0.984in.]  
32: For  $\phi$  32 [1.260in.]  
40: For  $\phi$  40 [1.575in.]  
50: For  $\phi$  50 [1.969in.]  
63: For  $\phi$  63 [2.480in.]  
80: For  $\phi$  80 [3.150in.]  
100: For  $\phi$  100 [3.940in.]

Notes: 1. Purchased mounting brackets could not be installed to the product. Before ordering, always see and check p.213 "Bracket mounting."  
2. For  $\phi$  20 [0.787in.] and  $\phi$  25 [0.984in.], only N (rod end nut) is available.

### Mounting bracket contents

Model	Contents	pc.
1 - JCDA	Bracket:2 Mounting bolt:4	
2 - JCDA	Bracket:2 Mounting bolt:4	
3 - JCDA	Bracket:1 Mounting bolt:4	
N - JCDA	Hexagon nut:1	

### Contents of repair kit

Parts	Operation type		JCDAD
	Bore size	mm [in.]	
	20~100 [0.787~3.940]		
⑦ Rod seal			2
⑧ Piston seal			1
⑨ Tube gasket			2

Remark: ⑦, ⑧, ⑨ are part numbers on p.239.

## Inner Construction

### ● Double acting type (JCDAD)

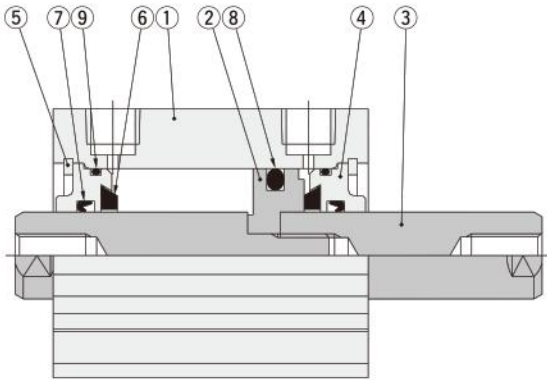

### ● Cylinder with magnet (JCDADS)

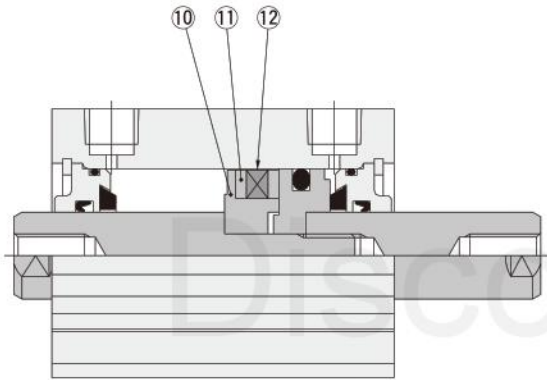

## Major Parts and Materials

No.	Parts	Bore size mm [in.]							
		20 [0.787]	25 [0.984]	32 [1.260]	40 [1.575]	50 [1.969]	63 [2.480]	80 [3.150]	100 [3.940]
①	Cylinder body	Aluminum alloy (anodized)							
②	Piston	Aluminum alloy (wear-resistant surface treatment)							
③	Piston rod	Stainless steel (chrome plated)		Steel (chrome plated)					
④	Rod cover	Aluminum alloy (wear-resistant surface treatment)							
⑤	Snap ring	Steel (black oxide finish)							
⑥	Bumper	Synthetic rubber (urethane rubber)							
⑦	Rod seal	Synthetic rubber (NBR)							
⑧	Piston seal	Synthetic rubber (NBR)							
⑨	Tube gasket	Synthetic rubber (NBR)							
⑩	Support	Aluminum alloy (anodized)							
⑪	Yoke	—		Mild steel (zinc plated)	—				
⑫	Magnet	Plastic magnet							

## Seals

Bore size mm [in.]	Parts	Rod seal	Piston seal	Tube gasket
20 [0.787]		MYN-10	PWP-20N	S-18
25 [0.984]		MYN-12	PWP-25N	S-22
32 [1.260]		MYN-16	PWP-32N	φ 29 × φ 1.5
40 [1.575]		DRP-16	PWP-40N	φ 39.5 × φ 1.5
50 [1.969]		DRP-20	PWP-50N	φ 49.5 × φ 1.5
63 [2.480]		DRP-20	PWP-63N	φ 62.5 × φ 1.5
80 [3.150]		DRP-25	PWP-80N	φ 77.3 × φ 1.5
100 [3.940]		DRP-30	PWP-100N	φ 98.5 × φ 2

## Mounting Bracket Materials

Parts	Materials
Rod end nut (for male thread)	Steel (zinc plated)
Foot bracket	Mild steel (black zinc plated)
Axial foot bracket	Mild steel (black zinc plated)
Flange bracket	Mild steel (black oxide finish)
Bracket mounting bolt	Steel (black oxide finish)

## Mass

### ● Double rod cylinders: Double acting type

g [oz.]

Bore size mm [in.]	Zero stroke mass (basic type)	Additional mass for each 1mm [0.0394in.] stroke	Additional mass of mounting bracket			Additional mass of other options			
			Foot bracket	Axial foot bracket	Flange bracket	Male thread piston rod	Cylinder with magnet	ZE□□□ switch	ZD136 switch
20 [0.787]	77.6 [2.737]	3.04 [0.107]	—	—	—	20 [0.71]	28.2 [0.995]	A:15 [0.53] B:35 [1.23]	C:270 [9.52]
25 [0.984]	103.9 [3.665]	4.09 [0.144]	—	—	—	40 [1.41]	38.2 [1.347]		
32 [1.260]	168.5 [5.944]	5.65 [0.199]	84 [2.96]	96 [3.39]	210 [7.41]	86 [3.03]	50.8 [1.792]		
40 [1.575]	228.8 [8.071]	6.40 [0.226]	100 [3.53]	110 [3.88]	275 [9.70]	86 [3.03]	72.0 [2.540]		
50 [1.969]	361.4 [12.75]	9.76 [0.344]	150 [5.29]	160 [5.64]	415 [14.64]	148 [5.22]	109.3 [3.855]		
63 [2.480]	549.5 [19.38]	11.01 [0.388]	240 [8.47]	260 [9.17]	560 [19.75]	148 [5.22]	156.1 [5.506]		
80 [3.150]	1150.7 [40.59]	17.54 [0.619]	500 [17.64]	520 [18.34]	1515 [53.44]	324 [11.43]	247.0 [8.713]		
100 [3.940]	1972.5 [69.58]	24.37 [0.860]	580 [20.46]	590 [20.81]	1950 [68.78]	582 [20.53]	360.3 [12.71]		

Notes: 1. "With double-sided mounting thread" has the same mass as the basic type.

2. Includes the mass for bracket mounting bolts, the rod end nut in the male thread specifications, and the sensor switch mounting brackets.

3. The sensor switch codes A, B, and C show the lead wire lengths. (A:1000mm [39in.], B:3000mm [118in.], C:5000mm [197in.] )

Calculation example: For the mass of double acting type cylinder with magnet, bore size of 25mm, stroke of 30mm, and with 2 sensor switches (ZE135A)  
 $103.9 + 38.2 + (4.09 \times 30) + (15 \times 2) = 294.8\text{g} [10.40\text{oz.}]$

# Dimensions of Double Rod Cylinder Double Acting Type (mm)

● Basic type JCDAD □ Bore size × Stroke (φ 20, φ 25)

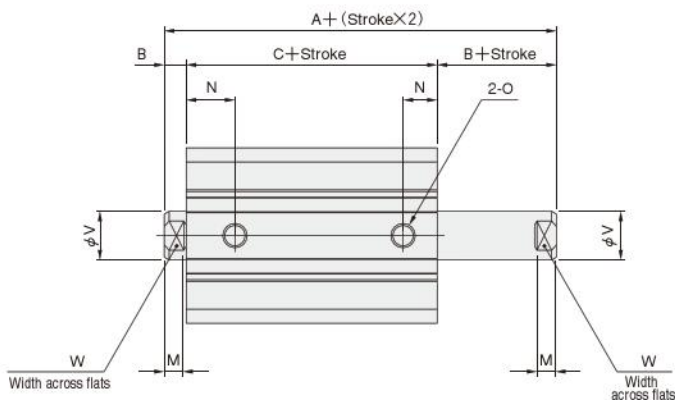
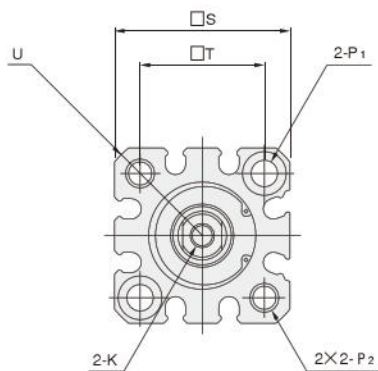

JIG CYLINDERS JC SERIES

● Basic type JCDAD □ Bore size × Stroke (φ 32~φ 100)

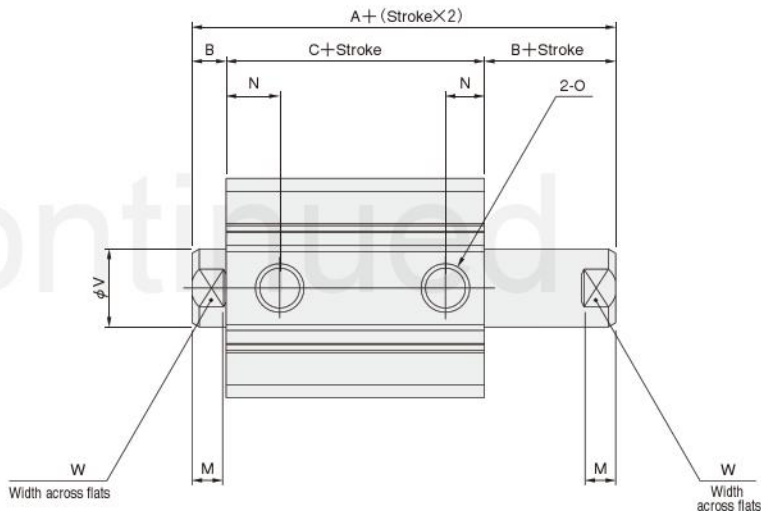
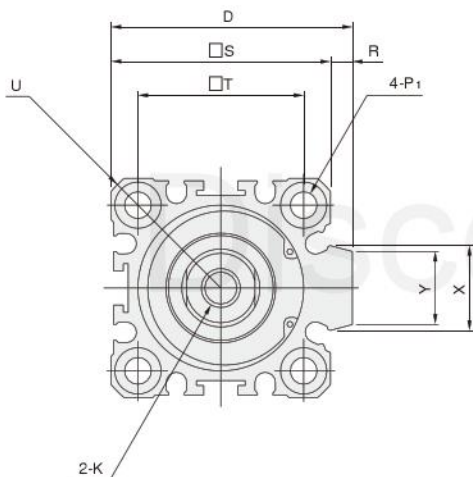

Type Code	Standard cylinder (JCDAD)			Cylinder with magnet (JCDADS)			D	K	M	N	O
	A	B	C	A	B	C					
20 [0.787]	35.5	4.5	26.5	45.5	4.5	36.5	—	M5×0.8 Depth7	4	10	M5×0.8
25 [0.984]	37.5	5	27.5	47.5	5	37.5	—	M6×1 Depth12	4.5	10	M5×0.8
32 [1.260]	47	7	33	57	7	43	49.5	M8×1.25 Depth13	6.5	11	Rc1/8
40 [1.575]	48.5	7	34.5	58.5	7	44.5	57	M8×1.25 Depth13	6.5	11.5	Rc1/8
50 [1.969]	51.5	8	35.5	61.5	8	45.5	71	M10×1.5 Depth15	7	12	Rc1/4
63 [2.480]	57	8	41	67	8	51	84	M10×1.5 Depth15	7	14.5	Rc1/4
80 [3.150]	73.5	10	53.5	83.5	10	63.5	104	M16×2 Depth21	9	16.5	Rc3/8
100 [3.940]	87	12	63	97	12	73	123.5	M20×2.5 Depth27	11	21	Rc3/8

Type Code	P <sub>1</sub>		P <sub>2</sub>	R	S	T	U	V	W	X	Y
	φ	Depth									
20 [0.787]	φ 5.5 (Through hole)	Counterbore φ 9 Depth 5.4 (Both sides)	M6×1 Depth10	—	36	25.5	R23.5	10	8	—	—
25 [0.984]	φ 5.5 (Through hole)	Counterbore φ 9 Depth 5.4 (Both sides)	M6×1 Depth10	—	40	28	R26	12	10	—	—
32 [1.260]	φ 5.5 (Through hole)	Counterbore φ 9 Depth 5.4 (Both sides)	—	4.5	45	34	R30	16	14	17.4	15
40 [1.575]	φ 5.5 (Through hole)	Counterbore φ 9 Depth 5.4 (Both sides)	—	5	52	40	R34.5	16	14	20.5	17.5
50 [1.969]	φ 6.6 (Through hole)	Counterbore φ 11 Depth 8 (Both sides)	—	7	64	50	R42.5	20	17	21.6	19
63 [2.480]	φ 9 (Through hole)	Counterbore φ 14 Depth 10.5 (Both sides)	—	7	77	60	R51	20	17	21.6	19
80 [3.150]	φ 11 (Through hole)	Counterbore φ 17.5 Depth 13.5 (Both sides)	—	6	98	77	R65	25	22	27.6	25
100 [3.940]	φ 11 (Through hole)	Counterbore φ 17.5 Depth 13.5 (Both sides)	—	6.5	117	94	R78	30	27	27.6	25

# Dimensions of Double Rod Cylinder Double Acting Type (mm)

● Foot mounting type JCDAD □ Bore size × Stroke -1

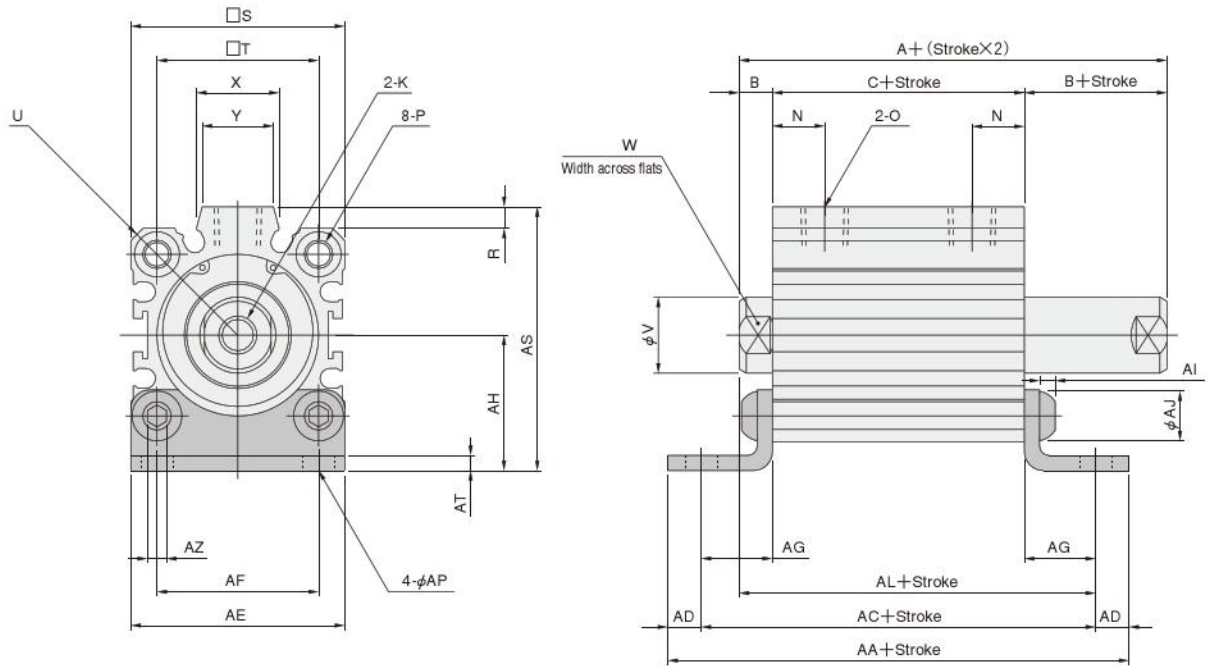

Discontinued

Type Bore mm [in.] Code	Standard cylinder (JCDAD)			Cylinder with magnet (JCDADS)			K	N	O
	A	B	C	A	B	C			
32 [1.260]	47	7	33	57	7	43	M8×1.25 Depth13	11	Rc1/8
40 [1.575]	48.5	7	34.5	58.5	7	44.5	M8×1.25 Depth13	11.5	Rc1/8
50 [1.969]	51.5	8	35.5	61.5	8	45.5	M10×1.5 Depth15	12	Rc1/4
63 [2.480]	57	8	41	67	8	51	M10×1.5 Depth15	14.5	Rc1/4
80 [3.150]	73.5	10	53.5	83.5	10	63.5	M16×2 Depth21	16.5	Rc3/8
100 [3.940]	87	12	63	97	12	73	M20×2.5 Depth27	21	Rc3/8

Type Bore mm [in.] Code	P						R	S	T	U	V	W	X	Y	JCDAD	JCDADS
	AA	AA														
32 [1.260]	Counterbore φ 9	Depth 5.4 (Both sides)	M 6X1	Depth from main body end 17.4 (Both sides)	4.5	45	34	R30	16	14	17.4	15	77	87		
40 [1.575]	Counterbore φ 9	Depth 5.4 (Both sides)	M 6X1	Depth from main body end 17.4 (Both sides)	5	52	40	R34.5	16	14	20.5	17.5	78.5	88.5		
50 [1.969]	Counterbore φ 11	Depth 8 (Both sides)	M 8X1.25	Depth from main body end 22 (Both sides)	7	64	50	R42.5	20	17	21.6	19	89.5	99.5		
63 [2.480]	Counterbore φ 14	Depth 10.5 (Both sides)	M 10X1.5	Depth from main body end 28.5 (Both sides)	7	77	60	R51	20	17	21.6	19	103	113		
80 [3.150]	Counterbore φ 17.5	Depth 13.5 (Both sides)	M 12X1.75	Depth from main body end 35.5 (Both sides)	6	98	77	R65	25	22	27.6	25	131.5	141.5		
100 [3.940]	Counterbore φ 17.5	Depth 13.5 (Both sides)	M 12X1.75	Depth from main body end 35.5 (Both sides)	6.5	117	94	R78	30	27	27.6	25	141	151		

Type Bore mm [in.] Code	JCDAD	JCDADS	AD	AE	AF	AG	AH	AI	AJ	JCDAD	JCDADS	AP	AS	AT	AZ
	AC	AC								AL	AL				
32 [1.260]	63	73	7	45	34	15	28.5	4	10.5	55	65	6.6	55.5	3.2	4
40 [1.575]	64.5	74.5	7	53	40	15	32.5	4	10.5	56.5	66.5	6.6	63.5	3.2	4
50 [1.969]	71.5	81.5	9	64	50	18	38	5	14	61.5	71.5	9	77	3.2	5
63 [2.480]	81	91	11	77	60	20	44.5	6	17.5	69	79	11	90	3.2	6
80 [3.150]	103.5	113.5	14	100	77	25	58.5	7	21	88.5	98.5	14	113.5	4.5	8
100 [3.940]	113	123	14	117	94	25	67	7	21	100	110	14	132	4.5	8

# Dimensions of Double Rod Cylinder Double Acting Type (mm)

● Axial foot mounting type JCDAD □ Bore size × Stroke -2

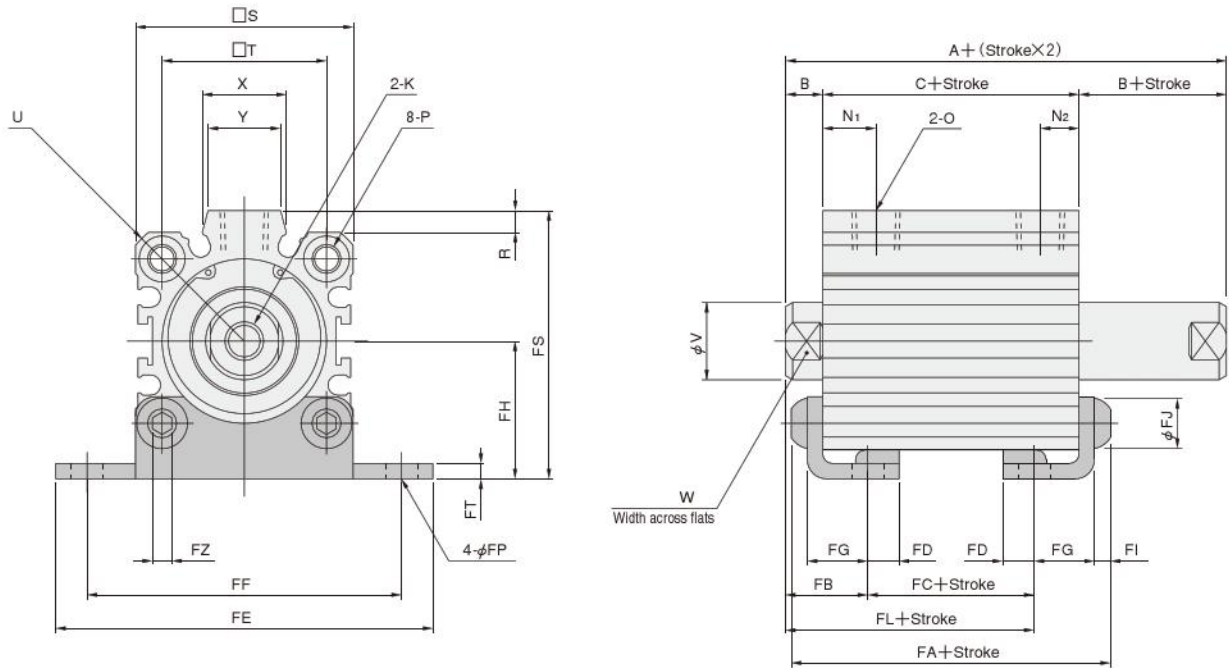

JIG CYLINDERS JC SERIES

Discontinued

Type Code	Standard cylinder (JCDAD)			Cylinder with magnet (JCDADS)			K	N	O
	A	B	C	A	B	C			
32 [1.260]	47	7	33	57	7	43	M8×1.25 Depth13	11	Rc1/8
40 [1.575]	48.5	7	34.5	58.5	7	44.5	M8×1.25 Depth13	11.5	Rc1/8
50 [1.969]	51.5	8	35.5	61.5	8	45.5	M10×1.5 Depth15	12	Rc1/4
63 [2.480]	57	8	41	67	8	51	M10×1.5 Depth15	14.5	Rc1/4
80 [3.150]	73.5	10	53.5	83.5	10	63.5	M16×2 Depth21	16.5	Rc3/8
100 [3.940]	87	12	63	97	12	73	M20×2.5 Depth27	21	Rc3/8

Type Code	P	R	S	T	U	V	W	X	Y	JCDAD	JCDADS	FB
										FA	FA	
32 [1.260]	Counterbore φ 9 Depth 5.4 (Both sides), M 6X1 Depth from main body end 17.4 (Both sides)	4.5	45	34	R30	16	14	17.4	15	47.4	57.4	16.3
40 [1.575]	Counterbore φ 9 Depth 5.4 (Both sides), M 6X1 Depth from main body end 17.4 (Both sides)	5	52	40	R34.5	16	14	20.5	17.5	48.9	58.9	16.3
50 [1.969]	Counterbore φ 11 Depth 8 (Both sides), M 8X1.25 Depth from main body end 22 (Both sides)	7	64	50	R42.5	20	17	21.6	19	51.9	61.9	18.8
63 [2.480]	Counterbore φ 14 Depth 10.5 (Both sides), M10X1.5 Depth from main body end 28.5 (Both sides)	7	77	60	R51	20	17	21.6	19	59.4	69.4	20.3
80 [3.150]	Counterbore φ 17.5 Depth 13.5 (Both sides), M12X1.75 Depth from main body end 35.5 (Both sides)	6	98	77	R65	25	22	27.6	25	76.5	86.5	26.5
100 [3.940]	Counterbore φ 17.5 Depth 13.5 (Both sides), M12X1.75 Depth from main body end 35.5 (Both sides)	6.5	117	94	R78	30	27	27.6	25	86	96	28.5

Type Code	JCDAD	JCDADS	FD	FE	FF	FG	FH	FI	FJ	JCDAD	JCDADS	FP	FS	FT	FZ
	FC	FC								FL	FL				
32 [1.260]	14.4	24.4	6.5	78	65	12.5	28.5	4	10.5	30.7	40.7	6.6	55.5	3.2	4
40 [1.575]	15.9	25.9	6.5	87	73	12.5	32.5	4	10.5	32.2	42.2	6.6	63.5	3.2	4
50 [1.969]	13.9	23.9	8	103	87	14	38	5	14	32.7	42.7	9	77	3.2	5
63 [2.480]	16.4	26.4	9.5	127	109	15.5	44.5	6	17.5	36.7	46.7	11	90	3.2	6
80 [3.150]	20.5	30.5	11	145	123	21	58.5	7	21	47	57	14	113.5	4.5	8
100 [3.940]	30	40	11	159	137	21	67	7	21	58.5	68.5	14	132	4.5	8

# Dimensions of Double Rod Cylinder Double Acting Type (mm)

● Rod side flange mounting type JCDAD □ Bore size × Stroke -3

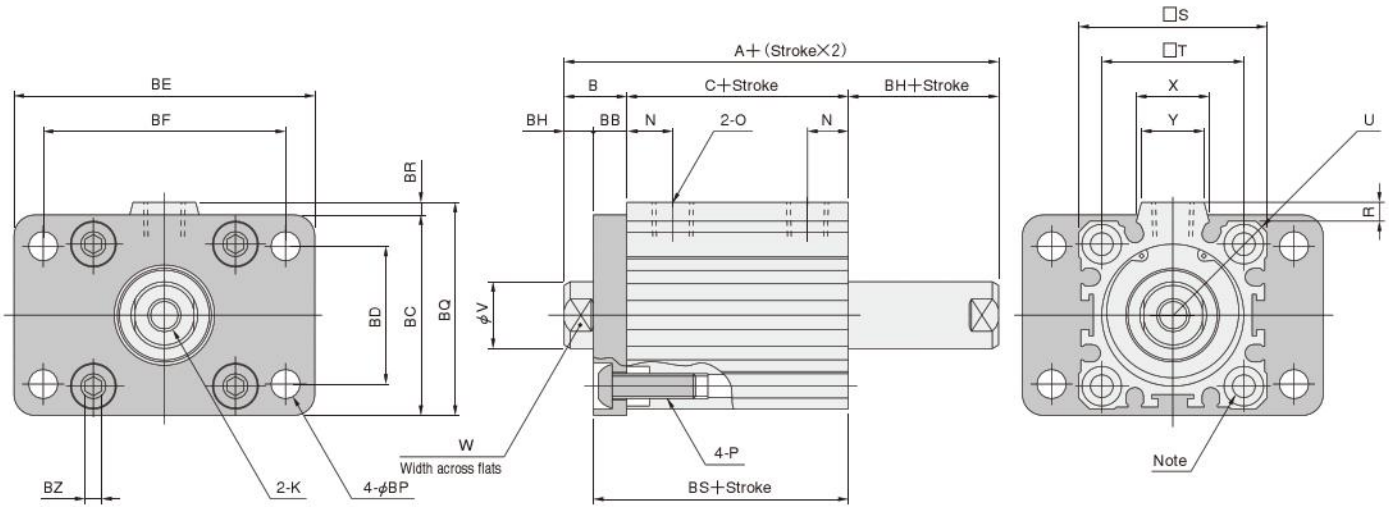

Note: Because tapped holes are on one side only, the flange mounting bracket cannot be mounted on the opposite side.

Discontinued

Type Code	Standard cylinder (JCDAD)			Cylinder with magnet (JCDADS)			K	N	O
	A	B	C	A	B	C			
32 [1.260]	55	15	33	65	15	43	M8×1.25 Depth13	11	Rc1/8
40 [1.575]	58.5	17	34.5	68.5	17	44.5	M8×1.25 Depth13	11.5	Rc1/8
50 [1.969]	61.5	18	35.5	71.5	18	45.5	M10×1.5 Depth15	12	Rc1/4
63 [2.480]	67	18	41	77	18	51	M10×1.5 Depth15	14.5	Rc1/4
80 [3.150]	89.5	26	53.5	99.5	26	63.5	M16×2 Depth21	16.5	Rc3/8
100 [3.940]	103	28	63	113	28	73	M20×2.5 Depth27	21	Rc3/8

Code	P	R	S	T	U	V	W	X	Y	BB
32 [1.260]	Counterbore φ 9 Depth 5.4 (Both sides), M 6X1 Depth from main body end 17.4 (one side)	4.5	45	34	R30	16	14	17.4	15	8
40 [1.575]	Counterbore φ 9 Depth 5.4 (Both sides), M 6X1 Depth from main body end 17.4 (one side)	5	52	40	R34.5	16	14	20.5	17.5	10
50 [1.969]	Counterbore φ 11 Depth 8 (Both sides), M 8X1.25 Depth from main body end 22 (one side)	7	64	50	R42.5	20	17	21.6	19	10
63 [2.480]	Counterbore φ 14 Depth 10.5 (Both sides), M 10X1.5 Depth from main body end 28.5 (one side)	7	77	60	R51	20	17	21.6	19	10
80 [3.150]	Counterbore φ 17.5 Depth 13.5 (Both sides), M 12X1.75 Depth from main body end 35.5 (one side)	6	98	77	R65	25	22	27.6	25	16
100 [3.940]	Counterbore φ 17.5 Depth 13.5 (Both sides), M 12X1.75 Depth from main body end 35.5 (one side)	6.5	117	94	R78	30	27	27.6	25	16

Type Code	BC	BD	BE	BF	BH	BP	BQ	BR	JCDAD	JCDADS	BZ
	BS	BS									
32 [1.260]	48	33	72	58	7	7	51	3	41	51	4
40 [1.575]	56	36	84	70	7	7	59	3	44.5	54.5	4
50 [1.969]	70	47	104	86	8	9	74	4	45.5	55.5	5
63 [2.480]	84	56	116	98	8	9	87.5	3.5	51	61	6
80 [3.150]	105	70	150	126	10	12	107.5	2.5	69.5	79.5	8
100 [3.940]	121	84	165	143	12	12	125.5	4.5	79	89	8

## With Double-sided Mounting Thread Dimensions (mm)

- Double acting type JCDAD  Bore size × Stroke -13
- $\phi 32 \sim \phi 100$

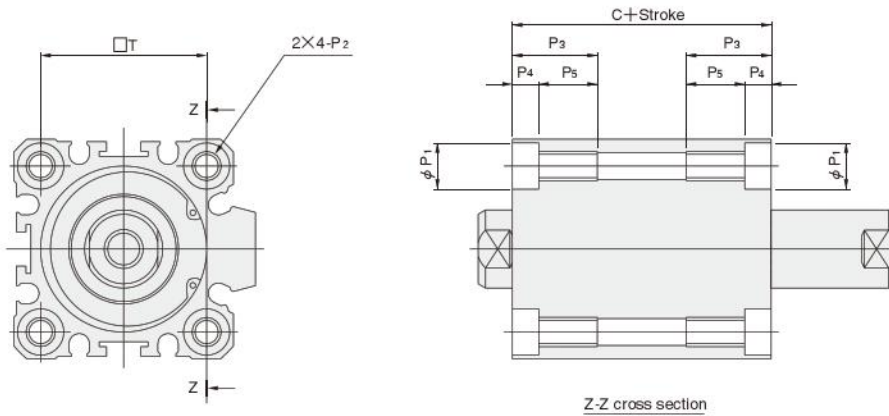

Bore mm [in.]	Code	P <sub>1</sub>	P <sub>2</sub>	P <sub>3</sub>	P <sub>4</sub>	P <sub>5</sub> Note	T
32 [1.260]		9	M6×1	17.4	5.4	12	34
40 [1.575]		9	M6×1	17.4	5.4	12	40
50 [1.969]		11	M8×1.25	22	8	14	50
63 [2.480]		14	M10×1.5	28.5	10.5	18	60
80 [3.150]		17.5	M12×1.75	35.5	13.5	22	77
100 [3.940]		17.5	M12×1.75	35.5	13.5	22	94

Note: When "C + Stroke" is less than the values shown below, the through thread is used.

Code	Bore mm [in.]	32 [1.260]	40 [1.575]	50 [1.969]	63 [2.480]	80 [3.150]	100 [3.940]
C+Stroke		38	39.5	45.5	61	73.5	73

- For dimensions not shown in this diagram, see the Double Rod Cylinders Basic Type.

## Dimensions of Male Rod End Thread Specification (mm)

- Double acting type JCDAD  Bore size × Stroke -B
- $\phi 20 \sim \phi 100$

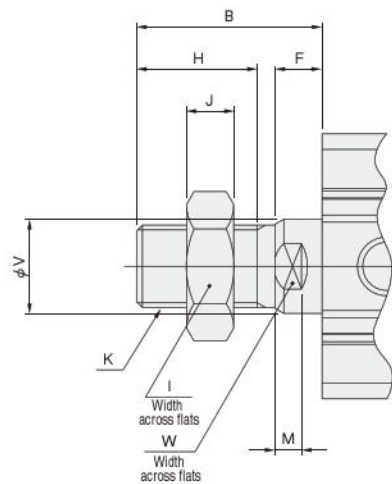

Bore mm [in.]	Code	B	F	H	I	J	K	M	V	W
20 [0.787]		18.5	4.5	12	13	5	M8×1.25	4	10	8
25 [0.984]		22.5	5	15	17	6	M10×1.25	4.5	12	10
32 [1.260]		28.5	5	20.5	22	8	M14×1.5	4.5	16	14
40 [1.575]		28.5	5	20.5	22	8	M14×1.5	4.5	16	14
50 [1.969]		33.5	5	25.5	24	11	M18×1.5	4	20	17
63 [2.480]		33.5	5	25.5	24	11	M18×1.5	4	20	17
80 [3.150]		43.5	8	32.5	30	13	M22×1.5	7	25	22
100 [3.940]		43.5	8	32.5	41	16	M26×1.5	7	30	27

- The double rod cylinder has male thread on both rod ends (rod end nuts come on both rod ends).

- The dimensions shown the above are values with the rod at retracted position.

Remark: Cylinder joints and cylinder rod ends are available for mounting with the rod end male thread specification (excluding  $\phi 20$ ).  
For details, see p.1568.

# JIG CYLINDERS JC SERIES

## Mounting Screws for Jig Cylinders

● Some types of mounting screws specifically for the Jig Cylinders are available.

Use the order codes below to place orders.

**List of Order Codes** ① Mounting screw type: JIS B 1176 Hexagon socket head cap screws  
② Surface treatment: Nickel plated

Applicable cylinder bore size mm [in.]	Mounting screw order code	Screw size	Number of supplied screws
20 [0.787] 25 [0.984] 32 [1.260] 40 [1.575]	CRK145	M5×35	4
	CRK146	M5×40	
	CRK147	M5×45	
	CRK148	M5×50	
	CRK149	M5×55	
	CRK150	M5×60	
	CRK151	M5×65	
	CRK152	M5×70	
	CRK153	M5×75	
	CRK154	M5×80	
	CRK155	M5×85	
	CRK156	M5×90	
	CRK157	M5×100	
	CRK158	M5×110	
50 [1.969]	CRK159	M6×40	4
	CRK160	M6×45	
	CRK161	M6×50	
	CRK162	M6×55	
	CRK163	M6×60	
	CRK164	M6×65	
	CRK165	M6×70	
	CRK166	M6×75	
	CRK167	M6×80	
	CRK168	M6×85	
	CRK169	M6×90	
	CRK170	M6×100	
	CRK171	M6×110	
	CRK172	M6×120	
	CRK173	M6×130	
	CRK174	M6×140	
	CRK175	M6×150	

Applicable cylinder bore size mm [in.]	Mounting screw order code	Screw size	Number of supplied screws		
63 [2.480]	CRK176	M8×60	4		
	CRK177	M8×65			
	CRK178	M8×70			
	CRK179	M8×75			
	CRK180	M8×80			
	CRK181	M8×85			
	CRK182	M8×90			
	CRK183	M8×95			
	CRK184	M8×100			
	CRK185	M8×110			
	CRK186	M8×120			
	CRK187	M8×130			
	CRK188	M8×140			
	CRK189	M8×150			
	CRK190	M8×160			
	CRK191	M8×170			
	80 [3.150] 100 [3.940]	CRK192		M10×65	4
		CRK193		M10×70	
		CRK194		M10×75	
		CRK195		M10×80	
CRK196		M10×85			
CRK197		M10×90			
CRK198		M10×95			
CRK199		M10×100			
CRK200		M10×110			
CRK201		M10×120			
CRK202		M10×130			
CRK203		M10×140			
CRK204		M10×150			
CRK205		M10×160			
CRK206		M10×170			

# SENSOR SWITCHES

Solid State Type, Reed Switch Type

## Symbols

● Double acting type



● Single acting push type

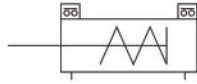

● Single acting pull type

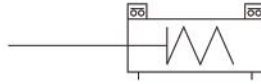

● Double rod cylinder double acting type



## Order Codes

□ □ - JCDAS

Lead wire length

A : 1000mm  
B : 3000mm

Series

JCDAS: Jig Cylinders JC Series with magnet

### Sensor switch type

ZE135 : Solid state type with indicator lamp, Horizontal lead wire	DC10~28V
ZE235 : Solid state type with indicator lamp, Vertical lead wire	DC10~28V
ZE101 : Reed switch type without indicator lamp, Horizontal lead wire	DC5~28V, AC85~115V
ZE201 : Reed switch type without indicator lamp, Vertical lead wire	DC5~28V, AC85~115V
ZE155 : Solid state type with indicator lamp, Horizontal lead wire	DC4.5~28V
ZE255 : Solid state type with indicator lamp, Vertical lead wire	DC4.5~28V
ZE102 : Reed switch type with indicator lamp, Horizontal lead wire	DC10~28V, AC85~115V
ZE202 : Reed switch type with indicator lamp, Vertical lead wire	DC10~28V, AC85~115V

● For details of sensor switches, see p.1544.

## Minimum Cylinder Strokes When Using Sensor Switches

		mm [in.]		
Type	Mounting Bore size	2 pcs. mounting		1 pc. mounting
		1-surface mounting 1-groove mounting	2-surface mounting	
Solid state type	20~100 [0.787~3.940]	15 <sup>Note</sup>	10	10
Reed switch type	20~100 [0.787~3.940]	20 <sup>Note</sup>	10	10

Note: The figures in the above table assume that the lead wires' opposing end surfaces are mounted facing each other toward the cylinder center.

## Moving Sensor Switch

- Loosening mounting screw allows the sensor switch to be moved along the switch mounting groove on the cylinder body.
- Tighten the mounting screw with a tightening torque of 0.1~0.2N·m [0.9~1.8in.lbf]. Overtightening could damage the sensor switch and actuator.

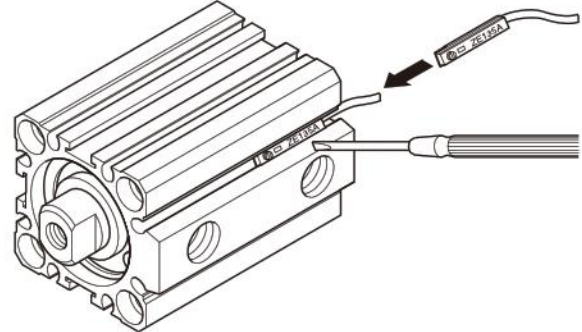

## Sensor Switch Operating Range, Response Differential, and Maximum Sensing Location

### ● Operating range: $\ell$

The distance the piston travels in one direction, while the switch is in the ON position.

### ● Response differential: C

The distance between the point where the piston turns the switch ON and the point where the switch is turned OFF as the piston travels in the opposite direction.

### ● Solid state type

Item	Bore size	20 [0.787]	25 [0.984]	32 [1.260]	40 [1.575]	50 [1.969]	63 [2.480]	80 [3.150]	100 [3.940]
Operating range: $\ell$		2.0~6.0 [0.079~0.236]	2.5~6.0 [0.098~0.236]	2.0~6.0 [0.079~0.236]	2.5~5.5 [0.098~0.217]	3.0~7.0 [0.118~0.276]	3.0~7.0 [0.118~0.276]	3.5~8.0 [0.138~0.315]	4.0~8.5 [0.157~0.335]
Response differential: C		1.0 [0.039] or less						1.5 [0.059] or less	
Maximum sensing location		6 [0.236]							

Note: The figures in the above table assume that they are lengths measured from the switch's opposite end side to the lead wire. The above table shows reference values.

### ● Reed switch type

Item	Bore size	20 [0.787]	25 [0.984]	32 [1.260]	40 [1.575]	50 [1.969]	63 [2.480]	80 [3.150]	100 [3.940]
Operating range: $\ell$		8.0~12.5 [0.315~0.492]	9.0~13.0 [0.354~0.512]	7.5~12.0 [0.295~0.472]	9.0~13.0 [0.354~0.512]	10.0~14.0 [0.394~0.551]	11.0~15.5 [0.433~0.610]	11.0~15.5 [0.433~0.610]	12.0~16.5 [0.472~0.650]
Response differential: C		1.5 [0.059] or less						2.0 [0.079] or less	
Maximum sensing location		10 [0.394]							

Note: The figures in the above table assume that they are lengths measured from the switch's opposite end side to the lead wire. The above table shows reference values.

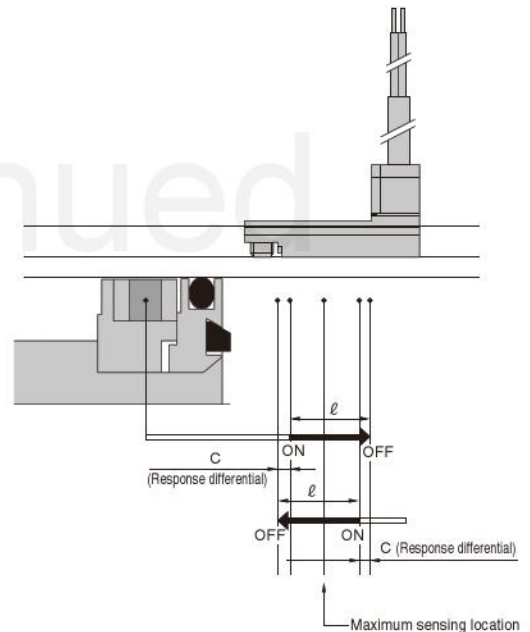

# Mounting Location of End of Stroke Detection Sensor Switches

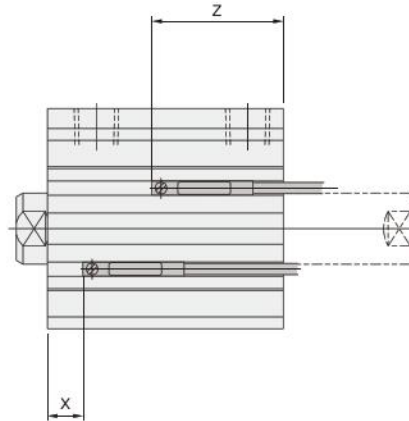
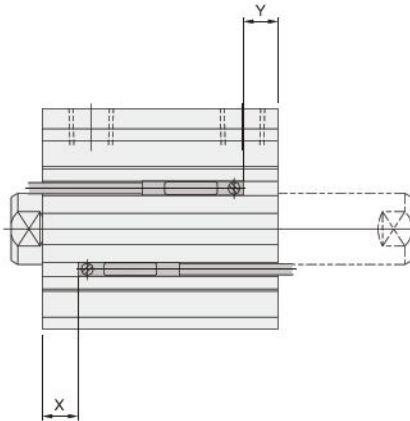

■ Standard cylinder: Double acting type, Single acting push type

● Solid state type: Double acting type mm [in.]

Code \ Bore size	20	25	32	40	50	63	80	100
X	10.5 [0.413]	10.0 [0.394]	11.5 [0.453]	16.0 [0.630]	16.0 [0.630]	18.5 [0.728]	21.5 [0.846]	24.5 [0.965]
Y	8.5 [0.335]	10.0 [0.394]	9.0 [0.354]	11.0 [0.433]	12.5 [0.492]	15.5 [0.610]	20.0 [0.787]	26.5 [1.043]
Z	21.5 [0.846]	22.5 [0.886]	21.5 [0.846]	23.5 [0.925]	25.0 [0.984]	28.0 [1.102]	32.5 [1.280]	39.0 [1.535]

● Solid state type: Single acting push type mm [in.]

Code \ Bore size \ Stroke	20		25		32		40		50	
	5~10	15~30	5~10	15~30	5~10	15~30	5~10	15~50	10~20	25~50
X	10.5 [0.413]	15.5 [0.610]	10.0 [0.394]	15.0 [0.591]	11.5 [0.453]	16.5 [0.650]	16.0 [0.630]	26.0 [1.024]	16.0 [0.630]	26.0 [1.024]
Y	8.5 [0.335]	8.5 [0.335]	10.0 [0.394]	10.0 [0.394]	9.0 [0.354]	9.0 [0.354]	11.0 [0.433]	11.0 [0.433]	12.5 [0.492]	12.5 [0.492]
Z	21.5 [0.846]	21.5 [0.846]	22.5 [0.886]	22.5 [0.886]	21.5 [0.846]	21.5 [0.846]	23.5 [0.925]	23.5 [0.925]	25.0 [0.984]	25.0 [0.984]

■ Double rod cylinder: Double acting type

● Solid state type: Double acting type mm [in.]

Code \ Bore size	20	25	32	40	50	63	80	100
X	10.5 [0.413]	10.0 [0.394]	11.5 [0.453]	16.0 [0.630]	16.0 [0.630]	18.5 [0.728]	21.5 [0.846]	24.5 [0.965]
Y	13.5 [0.531]	15.0 [0.591]	19.0 [0.748]	16.0 [0.630]	17.5 [0.689]	20.5 [0.807]	30.0 [1.181]	36.5 [1.437]
Z	26.0 [1.024]	27.5 [1.083]	31.5 [1.240]	28.5 [1.122]	30.0 [1.181]	33.0 [1.299]	42.5 [1.673]	49.0 [1.929]

● Reed switch type: Double acting type mm [in.]

Code \ Bore size	20	25	32	40	50	63	80	100
X	6.5 [0.256]	6.0 [0.236]	7.5 [0.295]	12.0 [0.472]	12.0 [0.472]	14.5 [0.571]	17.5 [0.689]	20.5 [0.807]
Y	4.5 [0.177]	6.0 [0.236]	5.0 [0.197]	7.0 [0.276]	8.5 [0.335]	11.5 [0.453]	16.0 [0.630]	22.5 [0.886]
Z	25.5 [1.004]	26.5 [1.043]	25.5 [1.004]	27.5 [1.083]	29.0 [1.142]	32.0 [1.260]	36.5 [1.437]	43.0 [1.693]

● Reed switch type: Single acting push type mm [in.]

Code \ Bore size \ Stroke	20		25		32		40		50	
	5~10	15~30	5~10	15~30	5~10	15~30	5~10	15~50	10~20	25~50
X	6.5 [0.256]	11.5 [0.453]	6.0 [0.236]	11.0 [0.433]	7.5 [0.295]	12.5 [0.492]	12.0 [0.472]	22.0 [0.866]	12.0 [0.472]	22.0 [0.866]
Y	4.5 [0.177]	4.5 [0.177]	6.0 [0.236]	6.0 [0.236]	5.0 [0.197]	5.0 [0.197]	7.0 [0.276]	7.0 [0.276]	8.5 [0.335]	8.5 [0.335]
Z	25.5 [1.004]	25.5 [1.004]	26.5 [1.043]	26.5 [1.043]	25.5 [1.004]	25.5 [1.004]	27.5 [1.083]	27.5 [1.083]	29.0 [1.142]	29.0 [1.142]

● Reed switch type: Double acting type mm [in.]

Code \ Bore size	20	25	32	40	50	63	80	100
X	6.5 [0.256]	6.0 [0.236]	7.5 [0.295]	12.0 [0.472]	12.0 [0.472]	14.5 [0.571]	17.5 [0.689]	20.5 [0.807]
Y	9.5 [0.374]	11.0 [0.433]	15.0 [0.591]	12.0 [0.472]	13.5 [0.531]	16.5 [0.650]	26.0 [1.024]	32.5 [1.280]
Z	30.0 [1.181]	31.5 [1.240]	35.5 [1.398]	32.5 [1.280]	34.0 [1.339]	37.0 [1.457]	46.5 [1.831]	53.0 [2.087]

## When Mounting Sensor Switches in Close Proximity

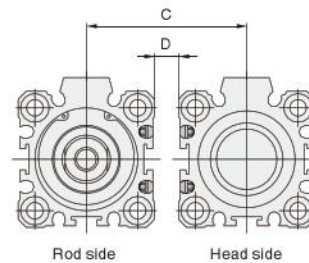
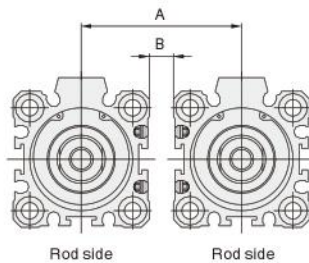

Bore size	Solid state type				Reed switch type			
	A	B	C	D	A	B	C	D
20 [0.787]	36 [1.417]	0	41 [1.614]	5 [0.197]	36 [1.417]	6 [0.236]	42 [1.654]	6 [0.236]
25 [0.984]	40 [1.575]		45 [1.772]		40 [1.575]		46 [1.811]	
32 [1.260]	45 [1.772]		50 [1.969]		51 [2.008]		53 [2.087]	
40 [1.575]	52 [2.047]		57 [2.244]		58 [2.283]		60 [2.362]	
50 [1.969]	64 [2.520]		69 [2.717]		70 [2.756]		74 [2.913]	
63 [2.480]	77 [3.031]		82 [3.228]		83 [3.268]		87 [3.425]	
80 [3.150]	98 [3.858]		103 [4.055]		104 [4.094]		108 [4.252]	
100 [3.940]	117 [4.606]		122 [4.803]		123 [4.843]		132 [5.197]	

● For the Handling Instructions and Precautions for Sensor Switches, see p.252.

# STRONG MAGNETIC FIELD RESISTANT SENSOR SWITCH

## Solid State Type

**ZD136C** is a sensor switch designed to operate normally without erratic operation even when used in spot welding lines or other areas subjected to strong magnetic field. A delay circuit (ON delay, OFF delay) and holding circuit inside the switch help it to avoid the effects of AC external magnetic fields to remain the switch's ON and OFF output. For the symbol, see p.246.

### Specifications

Item	Model	ZD136C
Wiring type		2-lead wires
Load voltage		DC10~28V
Load current		5~50mA
Internal voltage drop		5.0V MAX. (load current at 50mA) <sup>Note 1</sup>
Leakage current		1.0mA MAX
Response time		50ms MAX. 80ms MAX.
		ON delay = 40ms TYP. OFF delay = 65ms TYP. 30ms MIN. 50ms MIN.
Insulation resistance		100MΩ MIN. (DC500V megger between case and lead wire terminal)
Dielectric strength		AC500V (50/60Hz) for 1 minute (Between case and lead wire terminals)
Shock resistance <sup>Note 2</sup>		294.2m/s <sup>2</sup> [30G] (Non-repeated shock)
Vibration resistance <sup>Note 2</sup>		88.3m/s <sup>2</sup> [9G] (Total amplitude 1.5mm [0.059in.], 10~55Hz)
Protective structure		IP67 (IEC standard), JIS C0920 (watertight type)
Operation indicator	Setting range	When ON, a green LED indicator lights up
	Unstable range	When ON, a red LED indicator lights up
Lead wire <sup>Note 3</sup>		Oil-resistance, spatter-resistant cabtyre cable 2-lead, 0.5SQX ℓ
Magnetic field resistance <sup>Note 2</sup>		AC17000A
Ambient temperature		0~60°C [32~140°F]
Storage temperature range		-10~70°C [14~158°F]
Mass		270g [9.52oz.]

Notes: 1. When using a programmable controller with input voltage of 12V, care should be taken about the programmable controller's ON voltage. Effect of the sensor switch's internal voltage drop could sometimes prevent use of the device.  
2. According to Koganei test standards.  
3. Lead wire length ℓ C: 5000mm [197in.]

### Internal Circuit and Outline of Operations

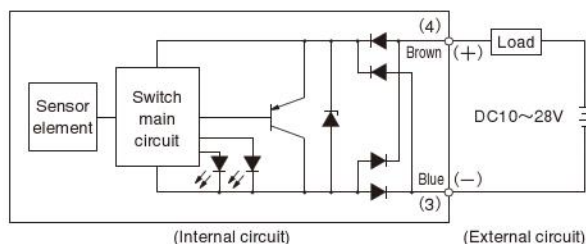

**Caution:** ZD136C is a non-polarity type. Connect either the brown or the blue lead wire to the load.

#### Outline of operations

Sensor switch	Magnetic field		Magnetic field	
	No disturbance by an AC magnetic field	Disturbance by an AC magnetic field	No disturbance by an AC magnetic field	Disturbance by an AC magnetic field
	Without magnet	With magnet	Without magnet	With magnet
Sensor element	OFF	ON	OFF↔ON	OFF↔ON
Sensor switch output	OFF	ON	OFF	ON

### Minimum Cylinder Strokes When Using Sensor Switches

		2 pcs. mounting			1pc. mounting
Type	Bore size	Mounting		10 <sup>Note</sup>	
		1-groove mounting	2-groove mounting		
Strong magnetic field type	32~50	100	—	5 <sup>Note</sup>	
	63~100	70	100		

Note: The values in the table above are related to the lead wire bending radius (strong magnetic field type has a minimum bending radius 25mm [0.984in.]), and allow the lead wire protruding from the cylinder body to outside when bent to the minimum. For the minimum stroke value when lead wires are not protruding from the cylinder body to outside, see the table below.

		Lead wire protrusion direction	
Type	Bore size	mm [in.]	
		Head cover side	Rod cover side
Strong magnetic field type	32 [1.260]	55	55
	40 [1.575]	55	50
	50 [1.969]	55	50
	63 [2.480]	50	50
	80 [3.150]	45	45
	100 [3.940]	40	40

● The strong magnetic field resistant sensor switch can be used in locations subjected to disturbance by AC magnetic fields (areas near AC welder etc.). The strong magnetic field resistant sensor switch has a function of changing its switch output only when the magnetic field is applied for a fixed period of time in an ON or OFF state. Magnetic fields generated by welding currents at areas near AC welder change the current at set intervals, and the magnetic field is not continuously generated longer than the time required for changing the sensor switch output. Therefore, the sensor switch output is not affected by magnetic fields generated by welding current from AC welding equipment.

**Caution:** The sensor switch cannot be used in areas near DC welder (including inverters), because the magnetic fields generated by the welding equipment remain constant.

● **In the case of no disturbance by an AC magnetic field**  
When a sensor element detects the magnetic field of a magnet, the sensor switch output changes to ON about 40ms later. When the magnetic field generated by the magnet disappears, sensor switch output returns to the OFF position about 65ms later.

● **In the case of existing disturbance by an AC magnetic field**  
Disturbance by an AC magnetic field causes sensor elements to switch repeatedly from ON to OFF states regardless of whether there is a magnet or not. However, use of an ON delay or OFF delay circuit allows sensor switch output to proceed without effect from disturbances by the AC magnetic field.

Order Code

**ZD136 C - JCDAS**

**Series**  
**JCDAS:** Jig Cylinders JC Series with magnet

**Lead wire length**  
**C:** 5000mm [197in.]

**Sensor switch type**  
**ZE136:** Strong magnetic field resistant sensor switch 2-lead wire Solid state type with indicator lamp  
 DC10~28V Horizontal lead wire

JIG CYLINDERS JC SERIES

Dimensions of Sensor Switch (mm)

● ZD136C-JCDAS

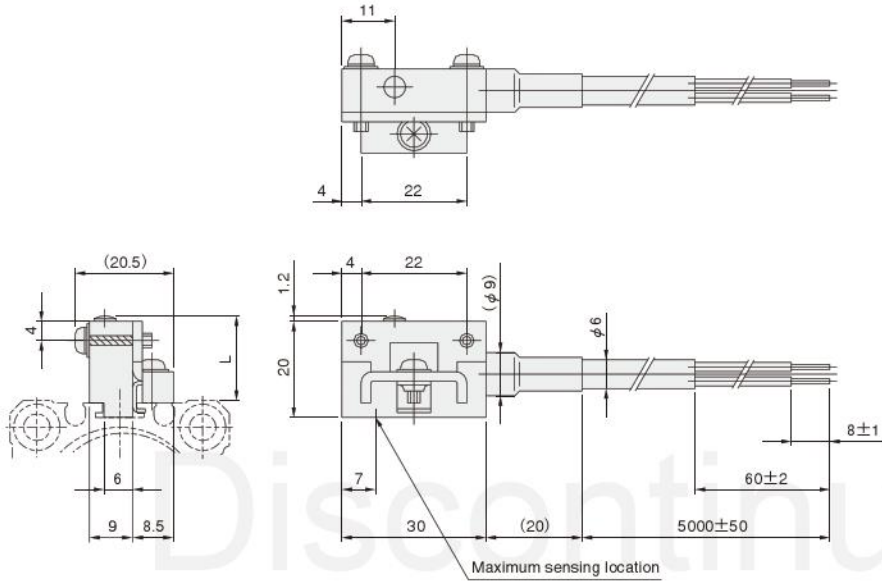

mm [in.]	
Bore size	L
32 [1.260]	17.5 [0.689]
40 [1.575]	18.0 [0.709]
50 [1.969]	17.5 [0.689]
63 [2.480]	17.5 [0.689]
80 [3.150]	16.5 [0.650]
100 [3.940]	17.0 [0.669]

Sensor Switch Operating Range, Response Differential, and Maximum Sensing Location

- Operating range:  $\ell$   
 The distance the piston travels in one direction, while the switch is in the ON position.
- Response differential: C  
 The distance between the point where the piston turns the switch ON and the point where the switch turns OFF as the piston travels in the opposite direction.

● Strong magnetic field type

		mm [in.]					
Item	Bore size	32	40	50	63	80	100
Operating range: $\ell$		2.5~6.0	3.0~6.5	3.5~7.0	4.0~7.5	4.5~8.0	4.5~8.5
		[0.098~0.236]	[0.118~0.256]	[0.138~0.276]	[0.157~0.295]	[0.177~0.315]	[0.177~0.335]
		(1.5~4.0)	(2.0~4.5)	(2.0~4.5)	(3.0~5.5)	(3.0~6.0)	(3.0~6.0)
		[0.059~0.157]	[0.079~0.177]	[0.079~0.177]	[0.118~0.217]	[0.118~0.236]	[0.118~0.236]
Response differential: C		1.0 [0.039] or less					
Maximum sensing location		7 [0.276]					

Notes: 1. The figures in the above table assume that they are measured from the opposite side of the lead wire. The above table shows reference values.  
 2. Figures in parentheses ( ) show the optimum adjustment range (green LED lights up).

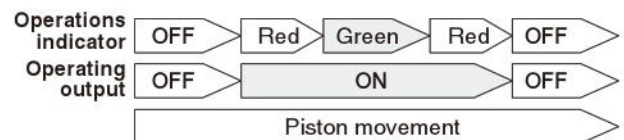
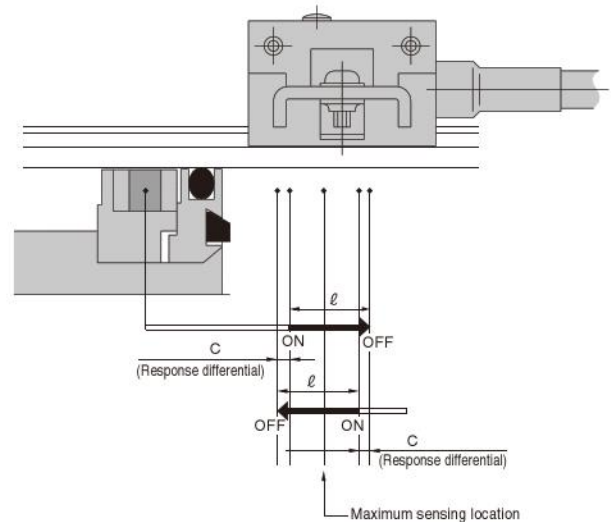

In an unstable range, the red LED lights up, while the green LED lights up when in the setting range.  
 Operating output is ON whenever an LED is lighted.  
 There is no change in operating output (sensor switch output) between the setting range and unstable range.

## Strong Magnetic Field Resistant Sensor Switch Wiring Instructions

Same as the wiring instructions for the 2-lead wire solid state sensor switch on p.1554.

## When Mounting Sensor Switches in Close Proximity

Sensor switches can be used even when contacting each other.

## Moving Sensor Switch

- Loosening mounting screw allows the sensor switch to be moved along the switch mounting groove on the cylinder body.
- Tighten the mounting screw with a tightening torque of 0.6 N·m [5.3in·lbf]. Overtightening could damage the sensor switch and actuator.

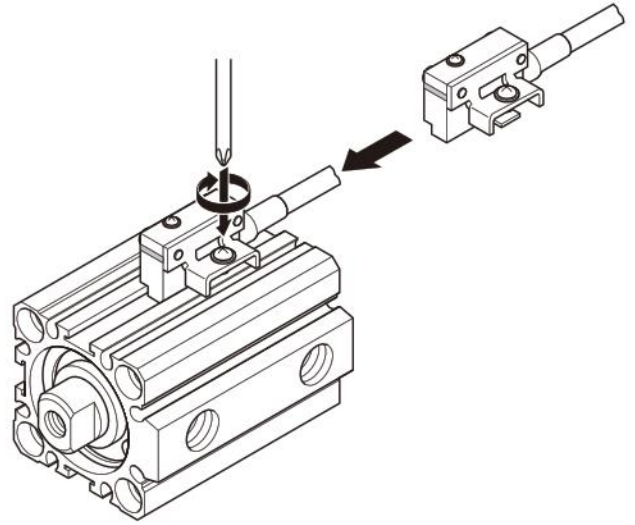

## Mounting Location of End of Stroke Detection Sensor Switch

When the sensor switch is mounted in the locations shown below (the figures in the tables are reference values), the magnet comes at the end of stroke to the maximum sensing location of the sensor switch.

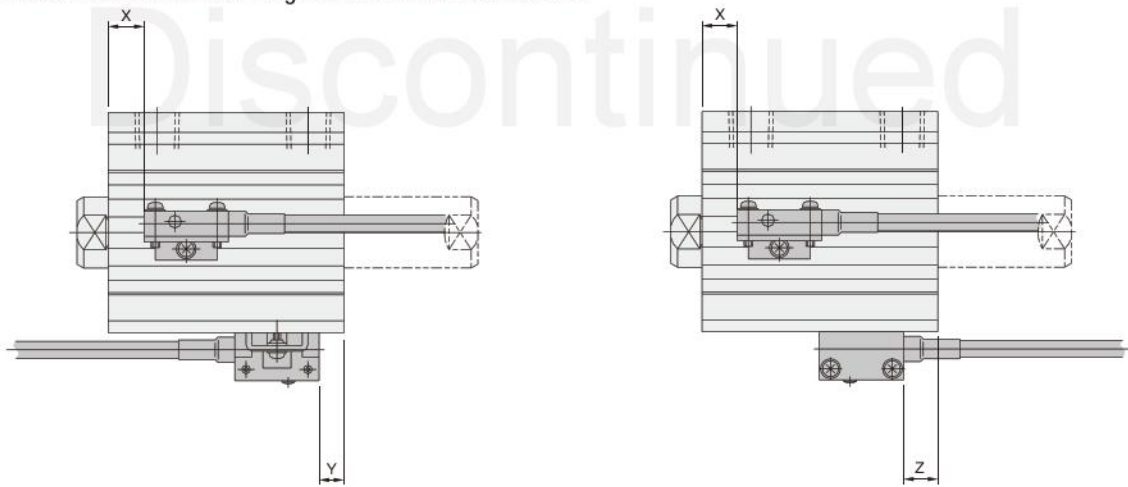

### ■ Standard cylinders: Double acting type, Single acting push type

#### ● Double acting type mm [in.]

Code \ Bore size	32 [1.260]	40 [1.575]	50 [1.969]	63 [2.480]	80 [3.150]	100 [3.940]
X	10.5 [0.413]	15.0 [0.591]	15.0 [0.591]	17.5 [0.689]	21.5 [0.846]	23.5 [0.925]
Y	8.0 [0.315]	10.0 [0.394]	11.5 [0.453]	14.5 [0.571]	19.0 [0.748]	25.5 [1.004]
Z	—	—	—	-1.5 [-0.059]	3.0 [0.118]	9.5 [0.374]

#### ● Single acting push type mm [in.]

Stroke Code	Bore size 32 [1.260]		40 [1.575]		50 [1.969]	
	5~10	15~30	5~10	15~50	10~20	25~50
X	10.5 [0.413]	15.5 [0.610]	15.0 [0.591]	20.0 [0.787]	15.0 [0.591]	20.0 [0.787]
Y	8.0 [0.315]	8.0 [0.315]	10.0 [0.394]	10.0 [0.394]	11.5 [0.453]	11.5 [0.453]
Z	—	—	—	—	—	—

### ■ Double rod cylinders: Double acting type

#### ● Double acting type mm [in.]

Code \ Bore size	32 [1.260]	40 [1.575]	50 [1.969]	63 [2.480]	80 [3.150]	100 [3.940]
X	10.5 [0.413]	15.0 [0.591]	15.0 [0.591]	17.5 [0.689]	20.5 [0.807]	23.5 [0.925]
Y	18.0 [0.709]	15.0 [0.591]	16.5 [0.650]	19.5 [0.768]	29.0 [1.142]	35.5 [1.398]
Z	2.0 [0.079]	-0.5 [-0.020]	0.5 [0.020]	3.5 [0.138]	13.0 [0.512]	19.5 [0.768]

### Wiring

1. For wiring work, excessively bending the lead wires, or applying too much pulling force on them, can lead to a break in the wiring. Allow plenty of margin when engaged in wiring work.
2. When the actuator mounting sensor switches is swaying, allow plenty of margin for the wiring. Repeated pulling or bending force could result in a break in the wiring.

### Mounting

For adjustment of the sensor switch mounting location, loosen the mounting screws, etc. Avoid use of hammers, etc., to perform adjustment, because the hammering could result in damage to internal elements or erratic operation.

### Environment

The sensor switch employs a sealed structure that offers a high degree of dust-proof and a fair degree of waterproof. Nevertheless, it cannot be used in locations that are constantly subjected to water or oil dripping.

### Electrical related precautions

1. Do not connect the sensor switch to a power supply directly, and always connect the load before connecting to a power supply. Direct connection to a power supply will damage the sensor switch.
2. When wiring the sensor switch, always shut off the power supply circuit before commencing the wiring work. Attempting operations while the power is ON could cause short circuit in the wiring that may result in damage to the sensor switch and also to other control equipment.
3. For use, do not let the operating voltage and current exceed ranges in the specifications. Because operations beyond the specifications range, or near the upper or lower limits could result in unstable operations, use at values that offer plenty of margin.

Discontinued

Discontinued